

| REV | ECO NO | DESCRIPTION | DRAWN | CHECK | DATE |
|------|--------|---------------------|-------|-------|------------|
| A.01 | - | PRELIMINARY RELEASE | BN | ZM | 2024-01-11 |

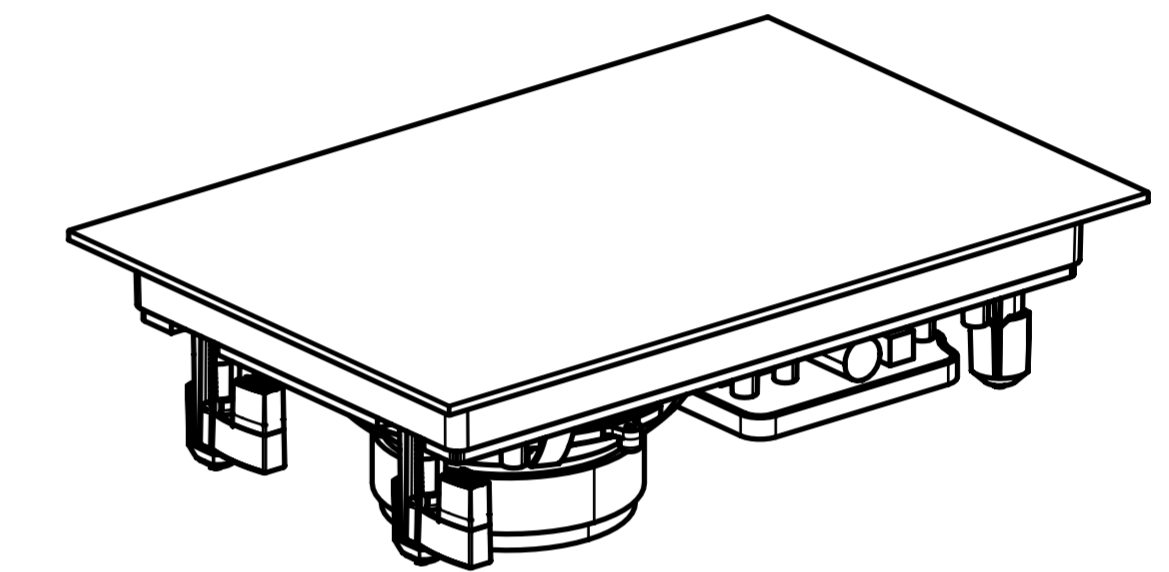

WITHOUT GRILLE

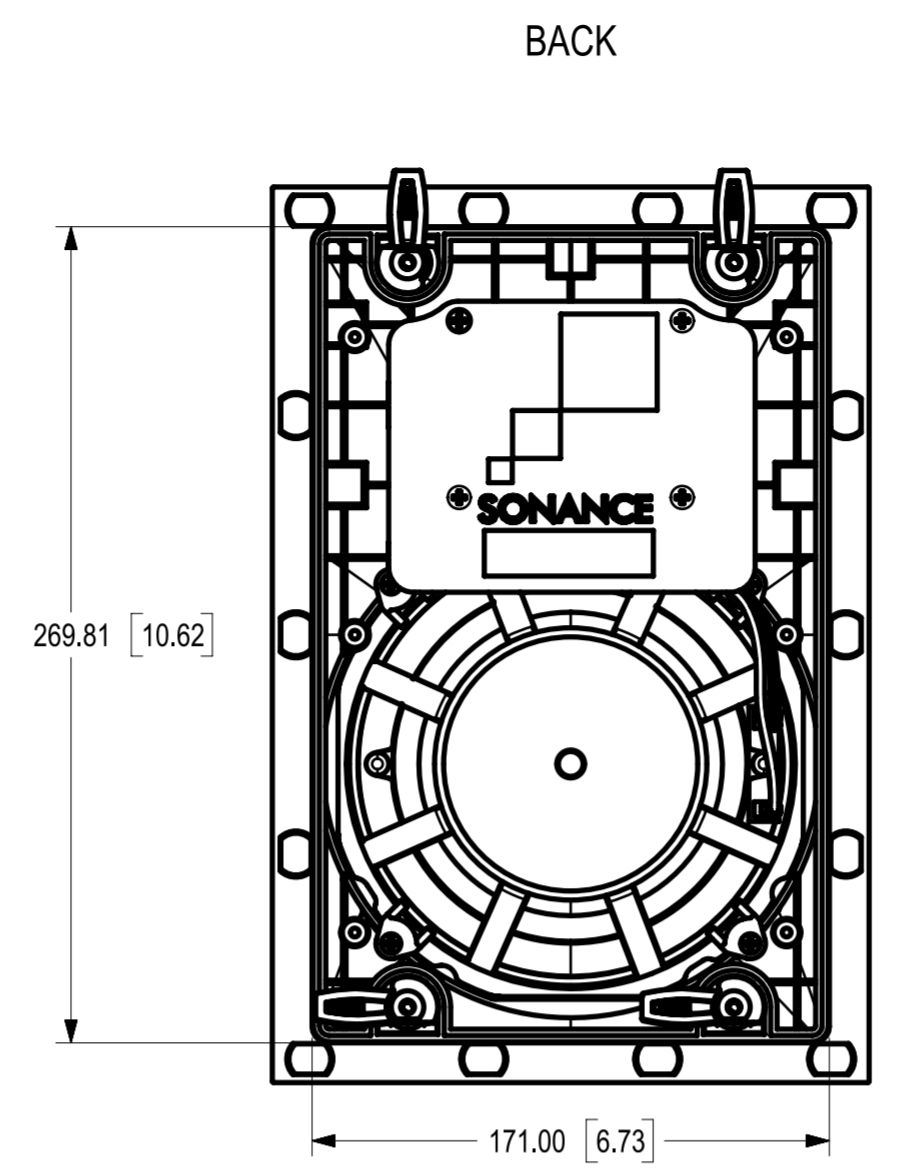
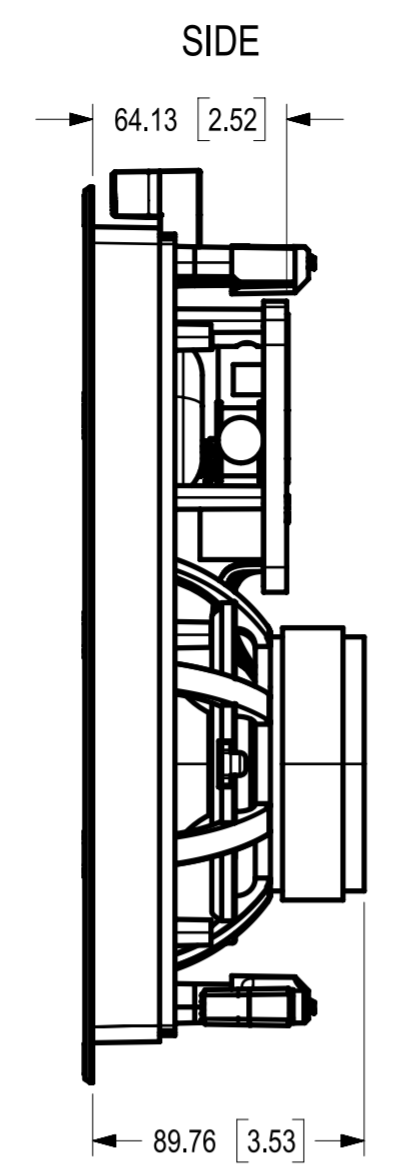
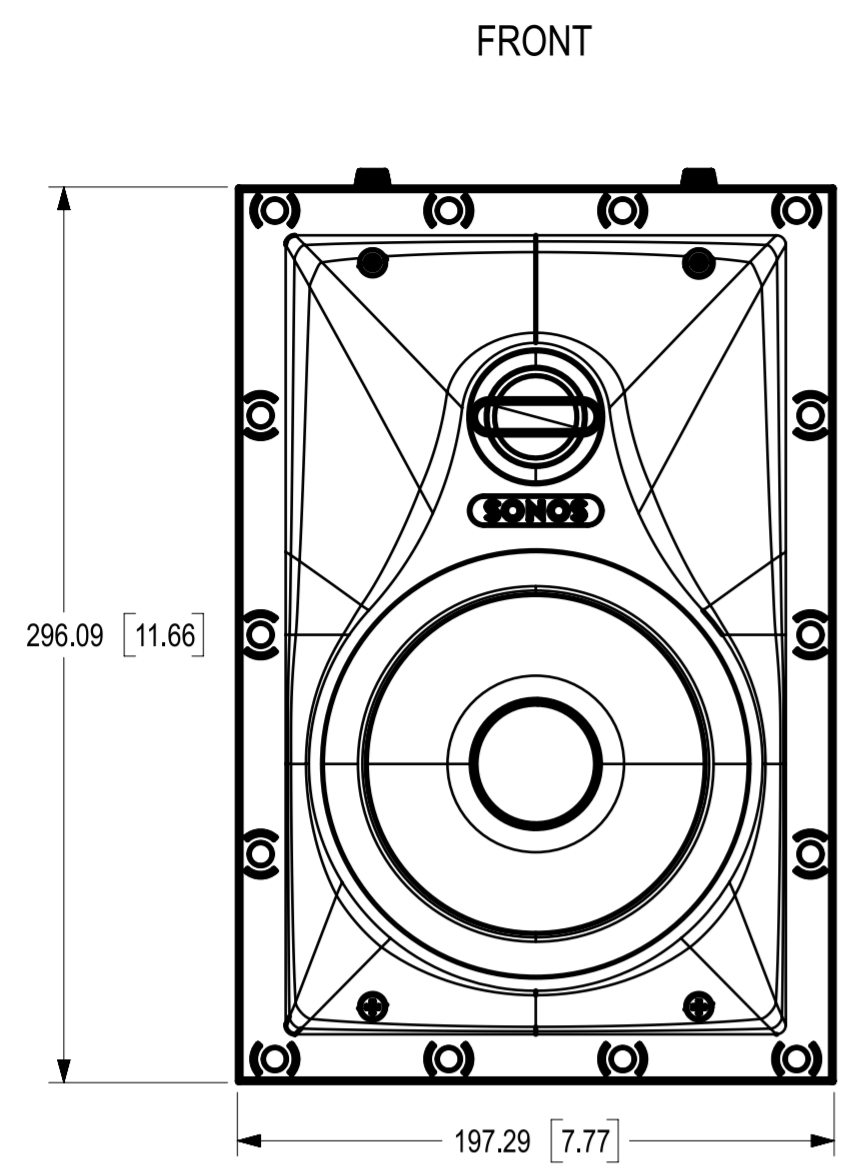
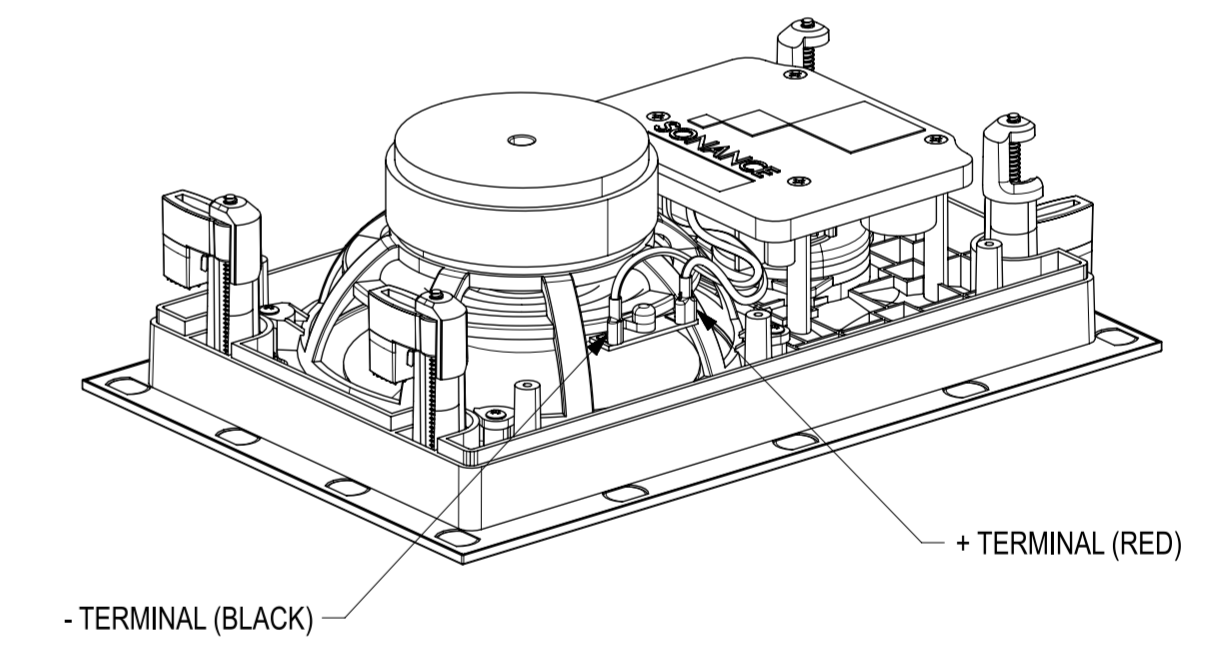
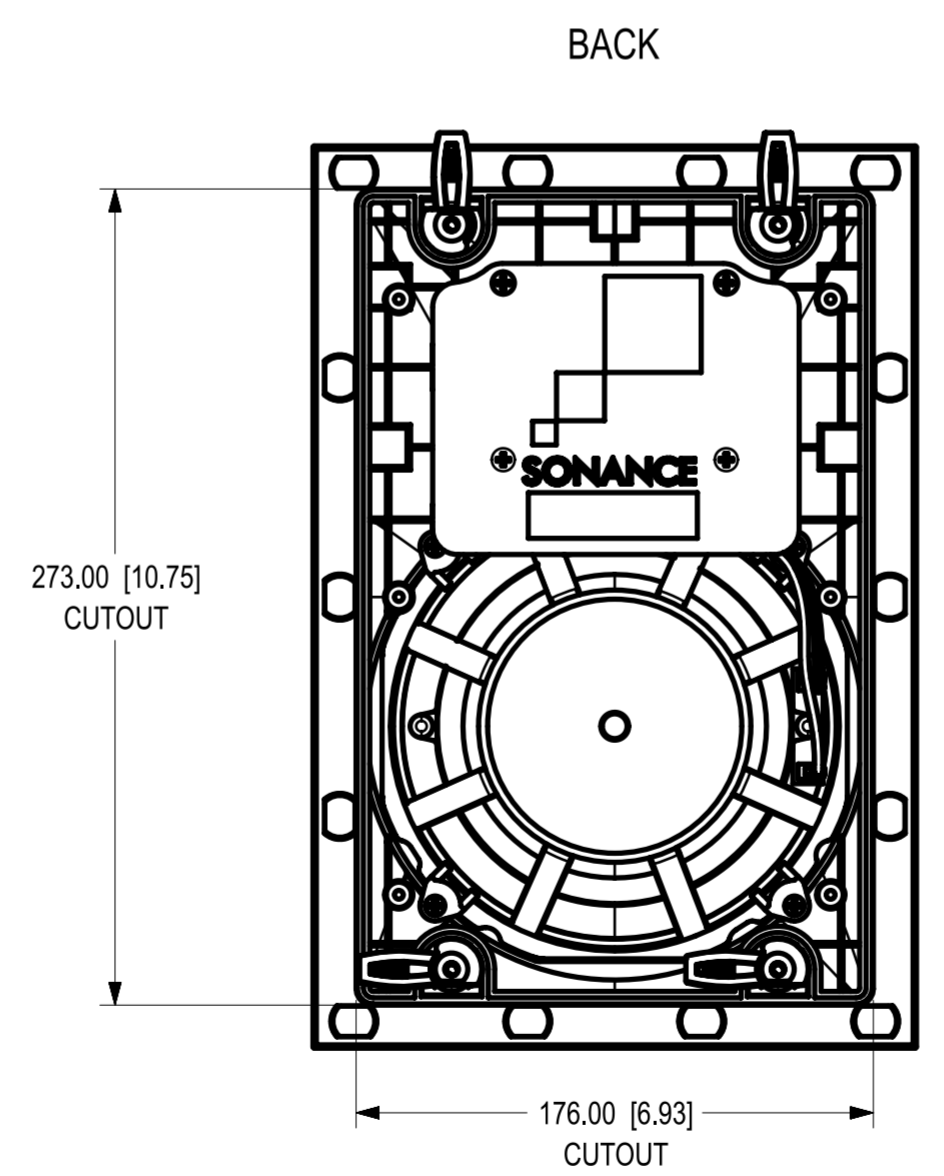
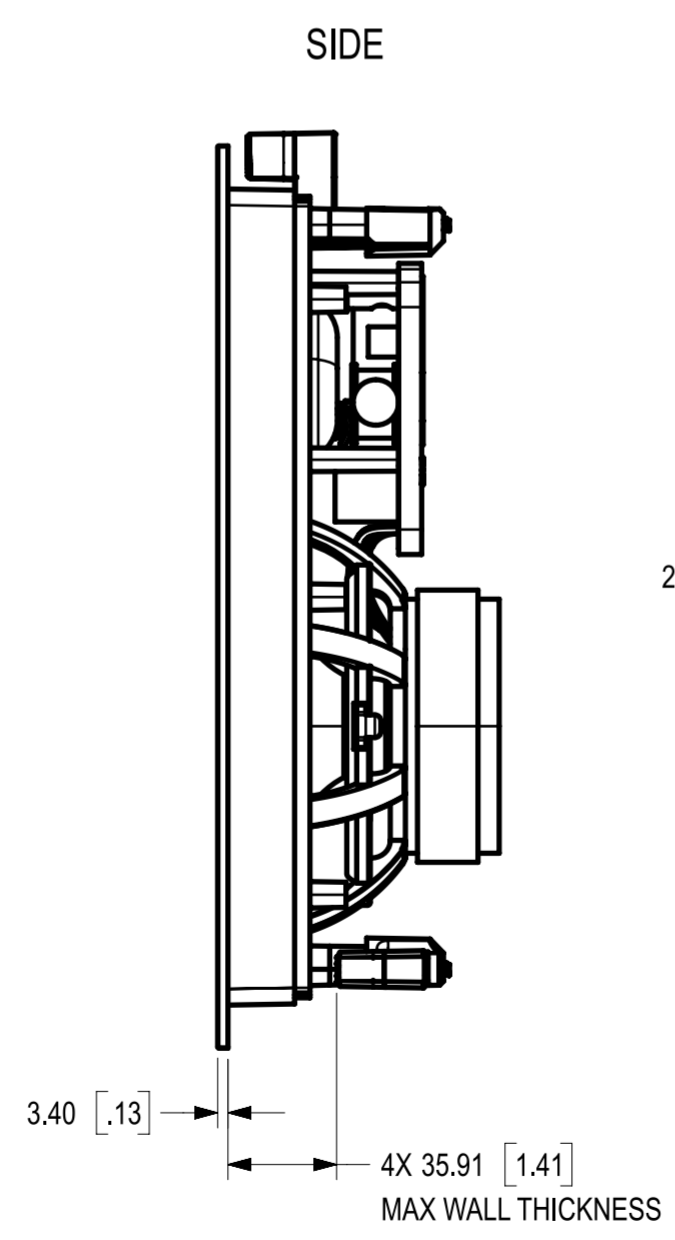
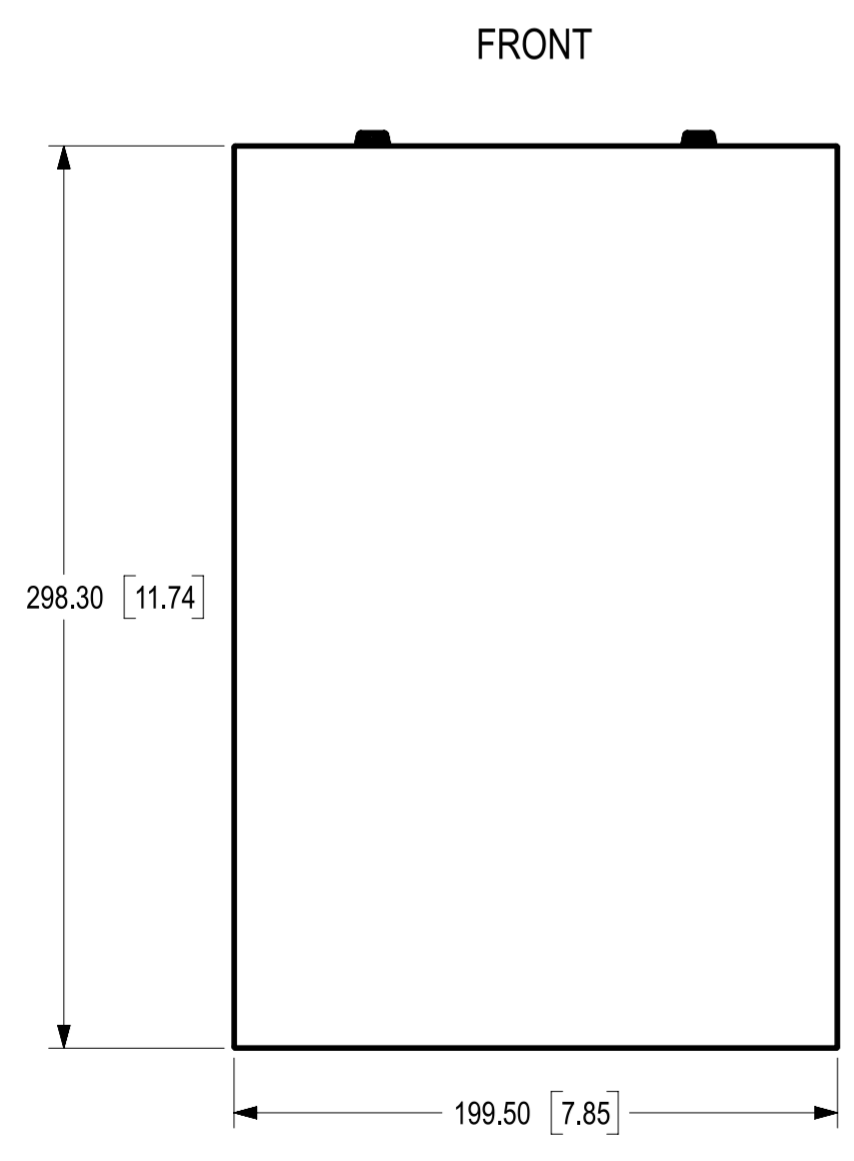

WITH GRILLE

NOTES:
1. DUAL DIMENSIONS: INCHES ARE IN BRACKETS

| | | | |
|--|----------------------------|------------------------------|------------------|
| SONOS | | | |
| TITLE: INSTALLER DRAWING, 6" IN-WALL SPEAKER | | | |
| SIZE: A2 | THIRD ANGLE PROJECTION | PART NO: 890-00549 | REV: A |
| SCALE: 2 : 5 | | SHEET: 1 OF 1 | |

THIS DOCUMENT AND THE INFORMATION CONTAINED HEREIN ARE PROPRIETARY TO SONOS INCORPORATED AND SHALL NOT BE USED BY, OR DISCLOSED IN WHOLE OR IN PART TO ANYONE OUTSIDE OF SONOS INCORPORATED WITHOUT THE PRIOR WRITTEN PERMISSION OF SONOS INCORPORATED.