

Spirit 2 User Manual



Spirit 2



Spirit 2 Remote

Acknowledgements

Thank you for choosing ePropulsion. We are committed to providing cleaner, safer, and more reliable electric propulsion solutions for your watercraft. We are confident you will be satisfied with our products and welcome you to visit our official website at www.epropulsion.com.

Important Information

Before using this product, please thoroughly read this manual to understand proper and safe operating procedures. Use of this product constitutes your agreement that you have fully read and understood all contents of this manual. Do not operate the electric outboard motor until you have carefully reviewed the instructions and understood its performance characteristics. Do not lend the outboard motor to individuals who are not proficient in its operation. ePropulsion Technology assumes no liability for any economic loss or personal injury resulting from operation inconsistent with this manual. This manual is subject to periodic updates. Please visit ePropulsion Technology's official website at www.epropulsion.com to obtain the latest version. If you find any discrepancies between your product and this manual, or have any questions regarding the product or this manual, please visit www.epropulsion.com or contact us. ePropulsion Technology reserves the final right of interpretation for this manual. This manual is available in multiple languages. In case of any discrepancies between different language versions, the English version shall prevail. ePropulsion Technology reserves the right to modify the manual content. ePropulsion Technology also retains all relevant intellectual property and industrial property rights, including copyrights, patents, trademarks, and designs.

Safety Warning

ePropulsion Technology places high importance on safety. We advise anyone closely interacting with ePropulsion products—such as those installing, operating, maintaining, or servicing them—to exercise caution, follow common sense, and adhere to the safety information in this manual and on the machine's installation stickers. This ensures the safety of personnel and property while minimizing safety risks.

The following symbols indicate relevant information on the manual or product label stickers: When a danger or warning symbol appears, it indicates a potentially hazardous or high-risk situation that, if not avoided, could result in death or serious personal injury. Pay special attention and take it seriously, as it concerns your safety or the safety of the product.



Important Notice Symbol:

Indicates usage tips or important information to help you quickly master the outboard motor and improve efficiency.



Important Tips or Warnings:

When installing, operating, maintaining, or servicing ePropulsion products, numerous safety hazards may exist during the process. Stay alert, perform relevant operations properly, and prioritize safety.

Product Serial Number

The product serial number is a crucial document for warranty claims and other after-sales services. The serial number for the "Spirit 2 Electric Outboard Motor" is located at the position shown in the image below. Please locate this position on the product and record the displayed serial number. Do not deface or scratch the serial number, as this will render it unreadable and void the product warranty.

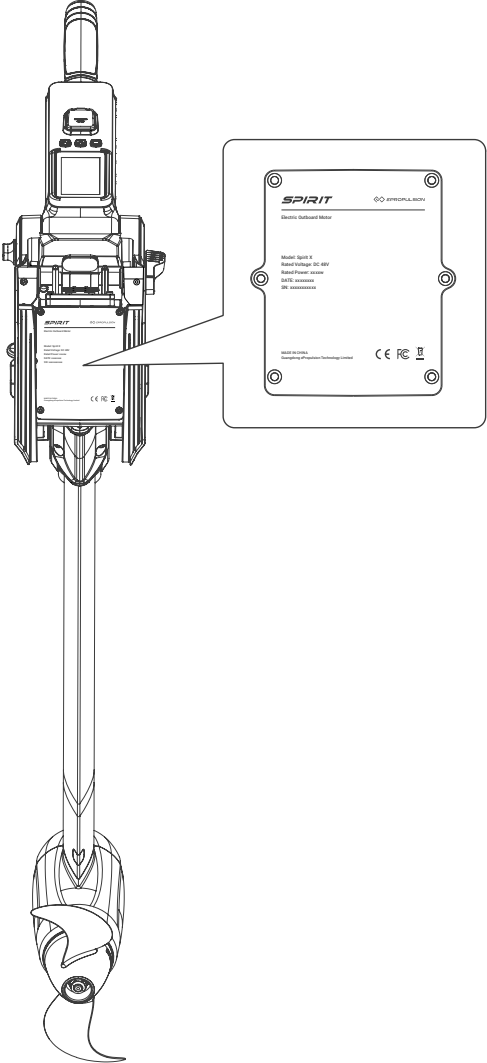

Table of Contents

Acknowledgements	1
Important Information	1
Safety Warning	1
Product Serial Number	3
1 Product Overview	7
1.1 In the Package.....	7
1.2 Parts and Diagram	9
1.3 Specifications.....	11
1.4 Important Notes Before You Start	14
1.4.1 Outboard Motor Selection	14
1.4.2 User Requirements	14
1.4.3 General Boating Recommendations.....	14
1.4.4 Special Precautions.....	15
1.4.5 EU Declaration of Conformity.....	15
1.4.6 FCC Compliance Statement.....	16
1.4.7 Disposal and Environment	16
2 Installation	17
2.1 Shaft Length Selection	17
2.2 Mounting Bracket	18
2.3 Pitch Angle Adjustment.....	21
2.4 Shallow Water Mode	21
2.5 Free Tilt-Up setting	22
2.6 Tilt Up	24
2.7 Quick Release	26
2.7.1 Quick-Release Installation	26
2.7.2 Quick-Release Removal	27
2.8 Heading Lock	28
2.9 Tiller Pitch Angle Adjustment	28
2.9.1 Free Mode.....	28
2.9.2 Tiller Fixed Angle.....	29
2.10 Extending the Tiller	30
2.11 Spirit Battery Installation and Removal	30
2.11.1 Battery Installation.....	30
2.11.2 Battery Removal.....	31



2.12 Connecting E-Series Batteries	33
2.13 Extension Cable Installation.....	35
2.14 Lanyard Hole	36
2.15 Remote Control Installation	36
2.16 Dual Configuration.....	37
3 Tiller Version Operation	38
3.1 Pre-startup Inspection Items	38
3.2 Kill Switch	38
3.3 Power On/Off	39
3.4 Throttle	39
3.5 Stopping the Outboard Motor	40
3.6 Steering.....	40
3.7 Button Functions	40
3.8 Main Interface.....	41
3.9 Boost Mode	42
3.10 Settings Page.....	42
3.11 Dark Mode	43
3.12 Brightness	43
3.13 Unit Settings.....	43
3.14 Software and Hardware Versions	44
3.15 Usage Data	44
3.16 Third-Party Battery Settings	44
3.17 Kill Switch Override Mode	45
3.18 Hydrogeneration	45
3.19 Errors	46
3.20 Battery Level Alert and Power Reduction Strategy	47
3.21 Throttle Calibration	48
3.22 Power Limit Setting	49
4 Remote Version Operation	50
4.1 LCD Display	50
4.2 Power Adjustment	53
4.3 Calibration	53
4.4 Using the kill switch.....	54
4.5 Warning Messages	55
4.6 Configuration.....	56



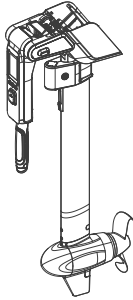
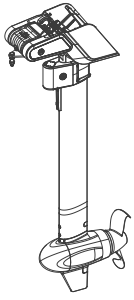
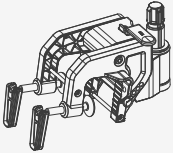
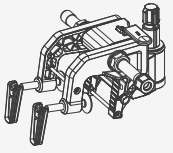

4.7 Battery Configuration.....	57
5 Emergency Operation	59
5.1 Impact Damage.....	59
5.2 Outboard Motor Accidental Submersion.....	59
6 Transportation and Storage	60
6.1 Transport	60
6.2 Storage	60
7 Maintenance and Care	61
7.1 Important Notes.....	61
7.2 Propeller Maintenance.....	61
7.3 Replacing the Anode.....	62
7.4 Maintenance of Electrical Contacts.....	63
7.5 Lubricating the Outboard Motor.....	63
7.6 Regular Maintenance.....	64
8 Warranty.....	65
8.1 Introduction	65
8.2 Limited Warranty.....	65
8.2.1 Overview.....	65
8.2.2 Product Registration	66
8.2.3 Important Limitations.....	67
8.2.4 Warranty Periods.....	68
8.2.5 Non-commercial Use	69
8.2.6 Commercial Use.....	69
8.2.7 Warranty Procedures	70
8.2.8 Excluded from the Limited Warranty	71
8.3 Miscellaneous	72

1 Product Overview

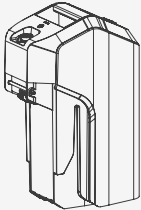
1.1 In the Package

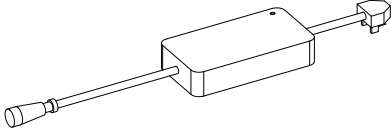
Open the product packaging and inspect for any shipping damage. Verify the completeness of the product kit against the following list. If shipping damage or missing items are found, contact your dealer immediately.

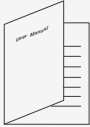
Product Name	Qty.	Tiller Version	Remote Version
Electric Outboard Motor	1		
Mounting Bracket	1		
Kill Switch & Wristband	2		/
Spirit Battery Ultra	/		

Product Name	Qty.	Tiller Version	Remote Version
Spirit Battery Charger Ultra	1		
Remote Steering Linkage	1	/	
Remote Installation Kit	1	/	
User Manual	1		
Quick Start	1		



Please keep the packaging of ePropulsion Technology products for storage.



Spirit batteries have four official chargers: Spirit Battery Standard Charger Ultra, Spirit Battery Fast Charger Ultra, Spirit Battery Solar Charger Ultra, and Spirit Battery 12V Charger Ultra.



For other accessories, please visit the official website of ePropulsion Technology at www.epropulsion.com.

1.2 Parts and Diagram

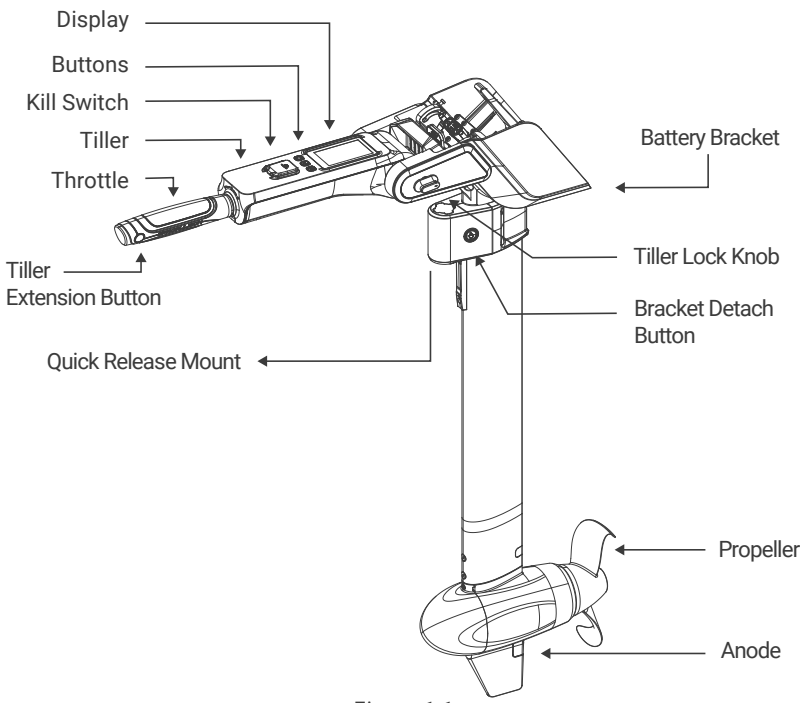

Figure 1-1

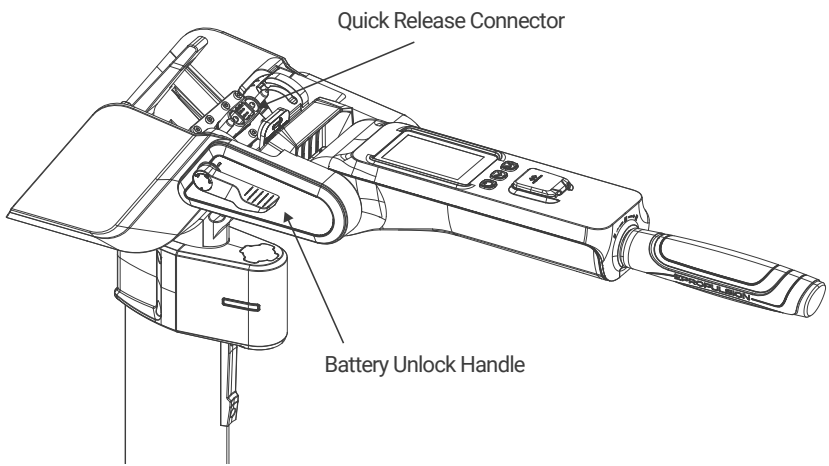

Figure 1-2

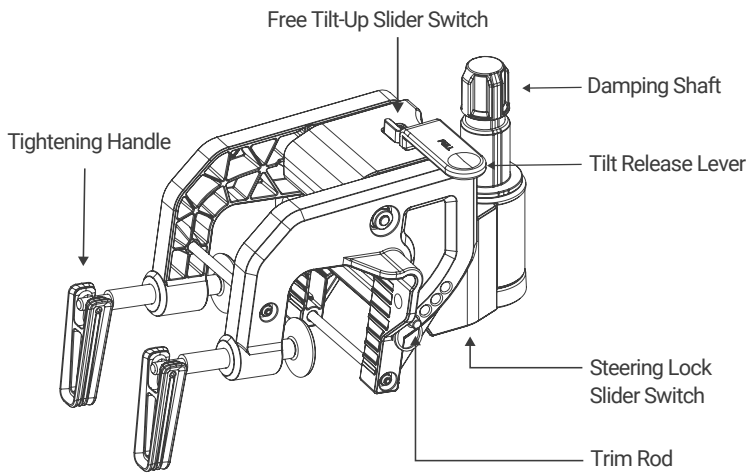

Figure 1-3

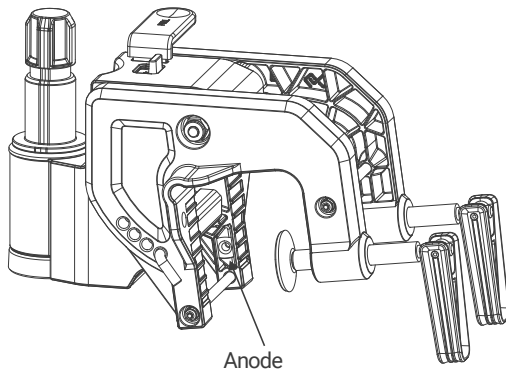

Figure 1-4

1.3 Specifications

Product Name	Electric Outboard Motor
Model	S2-XS ,S2-S, S2-L, S2R-S, S2R-L
Rated Input Power	2 kW
Peak Input Power	3 kW
Rated Input Voltage	48.1 VDC
Full Power Operating Voltage Range	45.6 VDC to 56 VDC
Weight	Tiller Version: XS: 10.1kg, S: 10.4kg, L: 10.6kg Tiller Version Mounting Bracket: 2.6kg Remote Version: S: 9.2kg, L: 9.5kg Remote Version Mounting Bracket: 3.0kg
Shaft Length	Tiller Version: XS: 525mm, S: 625mm, L: 750mm Remote Version: S: 625mm, L: 750mm
Dimension (L×W×H)	Tiller Version XS: 825mm x 190mm x 915mm S: 825mm x 190mm x 1015mm L: 825mm x 190mm x 1140mm Remote Version S: 544mm x 295mm x 1015mm L: 544mm x 295mm x 1140mm
Cooling Method	Natural water cooling
Rated RPM	1700 rpm to 2100 rpm
Tiller Tilt Angle	-90° to 80°
Tiller Fixed Angle	-90°, 0°, 45°, 80°
Steering Angle	±90°
Lift Angle	70°, 90°
Pitch Adjustment	0°, 7°, 14°, 21°
Shallow Water Angle	35°
Operating Temperature	-25°C to 55°C
Storage Temperature	-25°C to 70°C

Propeller	2-blade, Diameter 240mm, Pitch 167mm
Waterproof Rating	IP67

	Spirit Battery Ultra
Product Name	Rechargeable Li-ion Battery
Model	S48-32
Rated Energy	1539.2 Wh
Rated Capacity	32 Ah
Battery Type	Lithium-ion battery (NCM)
Cell Configuration	13S1P
Rated Voltage	48.1 VDC
Full Charge Voltage	55.25 VDC
Cut-off Voltage	35.75 VDC
Max Continuous Charging Current	20 A
Max Continuous Discharging Current	64 A
Charging Temperature	-15°C-60°C (Note: If the temperature is below 0°C, please use the Fast Charger with battery communication function)
Discharging Temperature	-10°C to 65°C
Waterproof Rating	IP67
Dimension (L×W×H)	394mm x 260mm x 167mm
Weight	10.4kg
Cycle Life	1000 cycles to 80% SOH*

*Note: At 25°C, 1C discharge + standard charger charging, 1000 charge/discharge cycles, 80% SOH retained.

External Battery Requirements:

Minimum Voltage	≥30 VDC
Maximum Voltage	≤60 VDC
Max Continuous Discharge Current	≥45 A



Please use third-party batteries with pre-charging capability (pre-charge current ≤ 30A).



After completing the wiring harness connection, first close the switch on the wiring harness, then turn on the battery switch, and finally power on the device.

Spirit Battery Ultra Charger Specifications:

Model	AP-PN240CH05460040
Input Voltage	100 - 240 V ~ 50/60 Hz
Maximum Input Current	5 A
Rated Output Voltage	54.6 VDC
Rated Output Current	4 A
Rated Power	218.4W
Efficiency	≥ 88 %
Operating Temperature	-10 to 40 °C
Storage Temperature	-40 to 70 °C
Protection Features	Reverse Polarity, Output Short Circuit, Output Overvoltage (OVP), Output Overcurrent (OCP), Over Temperature (OTP), Anti-backflow (Reverse Current Protection)
Certifications	CCC / CE-EMC / CE-LVD / FCC / RCM



Strictly prohibited: Using the "Spirit Battery Standard Charger Ultra" to charge other batteries. Strictly prohibited: Using non-official standard chargers to charge the "Spirit Battery Ultra".

1.4 Important Notes Before You Start

1.4.1 Outboard Motor Selection

Follow the instructions of the boat manufacturer and authorized dealers of "ePropulsion Technology" to select a suitable outboard motor. Do not exceed the maximum allowable power and do not overload the motor.

1.4.2 User Requirements

1. This product may only be operated by adults who have thoroughly read and understood this manual. Carefully review the complete user manual before operation. The user assumes full responsibility for all use and operation of this product, including any damage or malfunction resulting from failure to follow this manual.
2. This outboard motor should only be used when you are familiar with all aspects of operating a boat. If this is your first time using a boat, you should understand its behavior under various conditions, including tides, wind, and waves. Seek professional advice and guidance when necessary. If you have any questions about operating the outboard motor or the boat, consult your dealer before use.

1.4.3 General Boating Recommendations

Before operation:

1. Before operation, familiarize yourself with all functions and controls of this product. Ensure at least one other person on board is sufficiently familiar with the vessel and its systems to take over in an emergency.
2. Check weather conditions and consult forecasts before boating. Avoid boating in severe weather conditions.
3. Verify the presence and operability of adequate safety equipment, including but not limited to: life jackets, buoyancy aids or other personal flotation devices, fire extinguishers, bells, communication devices, and paddles.
4. Verify that the vessel and equipment comply with local safety regulations.
5. If the outboard motor is the vessel's sole source of power, ensure the battery has sufficient charge for your round trip. Calculate the distance and battery consumption for that distance, accounting for wind, tides, and other variables that may affect your journey.
6. Always report your navigation plan to family, friends, and relevant authorities.
7. Never operate an outboard motor after consuming alcohol or medication. Approximately 50% of boating accidents are alcohol-related.

During Operation:

1. All crew members must be equipped with and wear PFDs (Personal Flotation Devices, such as life jackets or buoyancy aids). PFDs must be worn at all times while boating.
2. The operator must always wear the kill switch lanyard (kill switch) by securing it to a safe location on the wrist, ankle, or clothing (buoyancy aid, jacket, etc.). If the operator falls overboard (or accidentally leaves the helm), the lanyard will pull the kill switch from the

throttle and stop the outboard motor.

3. Be vigilant for other boats, swimmers, and objects in the water. Exercise extreme caution near harbors, shorelines, or beaches, and avoid swimming areas whenever possible.
4. Immediately stop the outboard motor if someone falls overboard or in the event of a collision.

1.4.4 Special Precautions

1. If the outboard motor collides severely with an object in the water, stop operation immediately. Inspect the outboard motor for damage. If you believe it is safe to operate, return slowly to the nearest port. If you believe operation is unsafe, seek assistance and towing. In the above situations, the motor must be inspected by an authorized dealer of ePropulsion Technology before the next use.
2. The outboard motor must only be operated with the propeller submerged. Running the propeller out of the water is strictly prohibited.
3. Do not leave the outboard motor in the water if the vessel is powered by other means, such as sails.
4. After using the outboard motor in saltwater, promptly rinse it with fresh water.
5. Always keep the charging port securely closed. Clean all electrical contacts with an electronic contact cleaner every two months.
6. After use, lift the outboard motor above the water surface.
7. If the outboard motor malfunctions, the display will show an error code. Refer to the corresponding solution in this manual.

1.4.5 EU Declaration of Conformity

We Guangdong ePropulsion Technology Limited, hereby, declares that this equipment is compliance with the applicable Directives and European Norms, and amendments.

Object of the Declaration:

Product: Electric Outboard Motor

Model: S2-XS ,S2-S, S2-L, S2-A, S2-B, S2-C, S1-XS ,S1-S, S1-L, S1-A, S1- B, S1-C,S2R-S, S2R-L, S2R-A, S2R-B, S2R-C, S2R-D ,S1R-S, S1R-L, S1R- A, S1R-B, S1R-C, S1R-D

Product: Rechargeable Li-ion Battery

Model: S48-32

The object of the declaration is in conformity with the following directives and regulation:

Recreational Craft Directive (RCD) 2013/53/EU

Electromagnetic Compatibility (EMC) Directive2014/30/EU

Radio Equipment Directive (RED) 2014/53/EU

Restriction of Hazardous Substances Directive2011/65/EU and Delegated Directive (EU) 2015/863

EC REACH Regulation (EC 1907/2006)

EU Battery Regulation 2023/1542

Regulation on General Product Safety 2023/988



Applied Standards:

ISO 16315:2016

EN 60945: 2002

ETSI EN 301 489-1 V2.2.3

ETSI EN 301 489-17 V3.2.4

ETSI EN 300 328 V2.2.2:2019

EN 62479:2010;EN 50663:2017;

ISO 23625:2025 (Only for Battery)

IEC 62619:2022 ,IEC 62620:2014+AMD1:2023(Only for Battery)

This declaration of conformity is issued under the sole responsibility of the manufacturer:

Guangdong ePropulsion Technology Limited.

Address: Room 801, Building 1, 11 Daxue Road, Songshan Lake, Dongguan, Guangdong Province, China

Signature: 

Date: 2025.12.20

Shizheng Tao, Chief Executive Officer & Cofounder of Guangdong ePropulsion Technology Limited

1.4.6 FCC Compliance Statement

This equipment has been tested and found to comply with the limits for a Class A digital device, pursuant to part 15 of the FCC Rules. These limits are designed to provide reasonable protection against harmful interference when the equipment is operated in a commercial environment. This equipment generates, uses, and can radiate radio frequency energy and, if not installed and used in accordance with the instruction manual, may cause harmful interference to radio communications. Operation of this equipment in a residential area is likely to cause harmful interference in which case the user will be required to correct the interference at his own expense.

1.4.7 Disposal and Environment

This marking indicates that this product should not be disposed with other household wastes throughout the EU. To prevent possible harm to the environment or human health from uncontrolled waste disposal, recycle it responsibly to promote the sustainable reuse of material resources. To return your used device, please use the return and collection systems or contact the retailer where the product was purchased. They can take this product for environmental safe recycling.



2 Installation

2.1 Shaft Length Selection

Mounting height significantly affects boat speed. If mounted too high, the propeller will draw air, preventing the outboard motor from operating at maximum efficiency. If mounted too low, excessive resistance will hinder propulsion.

Transom Height	Recommended Model
300mm to 400mm	XS
400mm to 500mm	S
>500mm	L

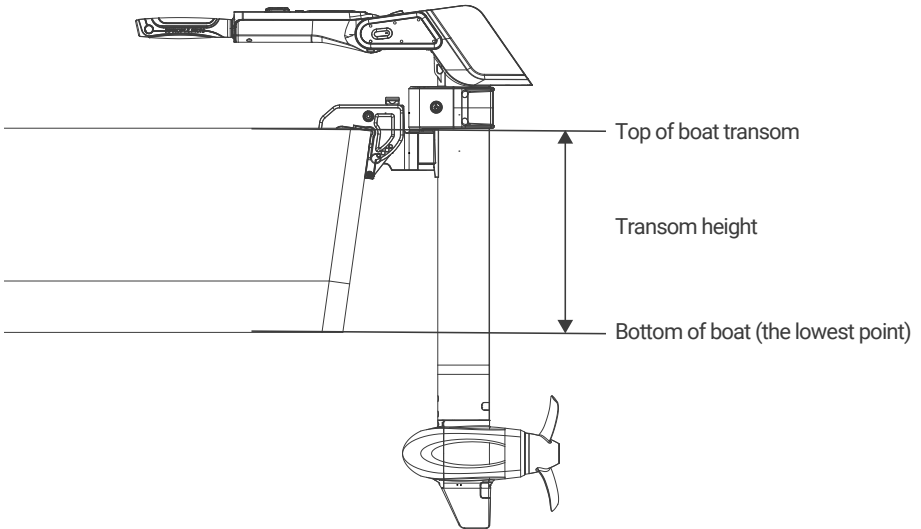

Figure 2-1

Please select the appropriate model based on your transom height. Mounting height significantly impacts boat speed. Alternatively, consult your dealer.

2.2 Mounting Bracket



Failure to properly secure the mounting bracket may cause the outboard motor to detach, resulting in property damage, serious injury, or death.



Before installing the mounting bracket, please check:

1. Verify that the mounting bracket functions properly.
2. Inspect for loose components.
3. Check the mounting bracket for cracks.

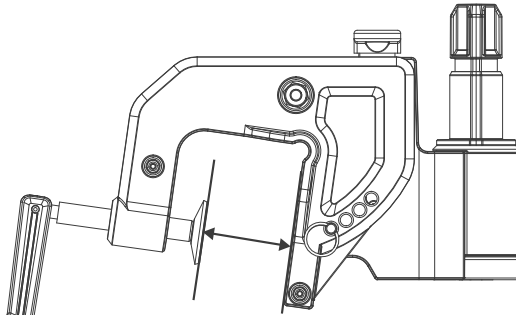

Transom thickness range:
28mm to 63mm

Figure 2-2

Step 1: Inspect the clamp.

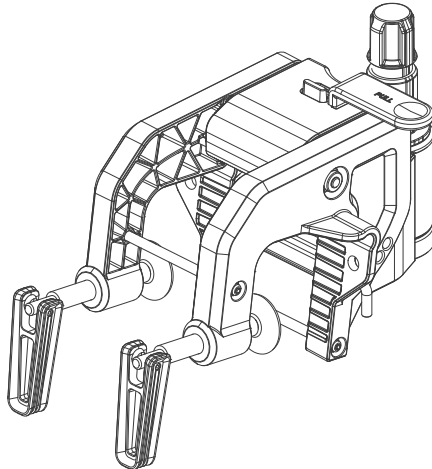

Figure 2-3

Step 2: Center the mounting bracket on the transom and rotate the handle to tighten and secure it.

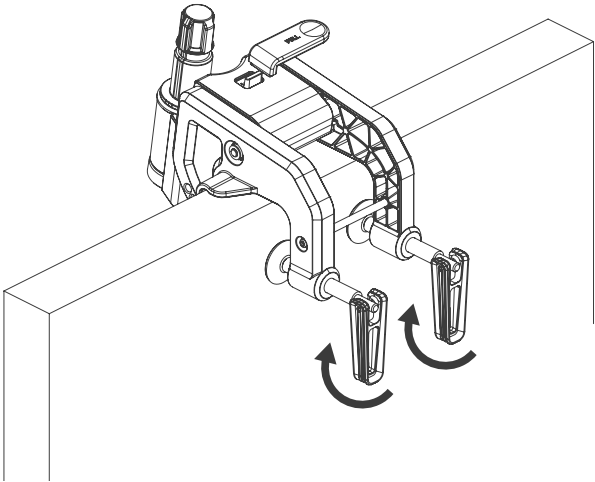

Figure 2-4

After confirming the handle is fully locked, secure the outboard motor to the hull using two screws. The dimensions of the two mounting holes are shown in the figure below.

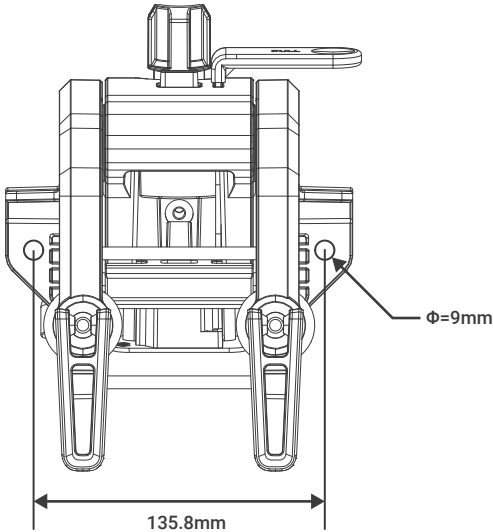

Figure 2-5



When using a single outboard motor, ensure this product is mounted on the boat's centerline. When using two outboard motors, ensure the product is mounted equidistant from the centerline on both sides, with a minimum spacing of 700 mm between outboards. For asymmetrical boat designs, consult an authorized ePropulsion Technology dealer to determine the appropriate mounting location.

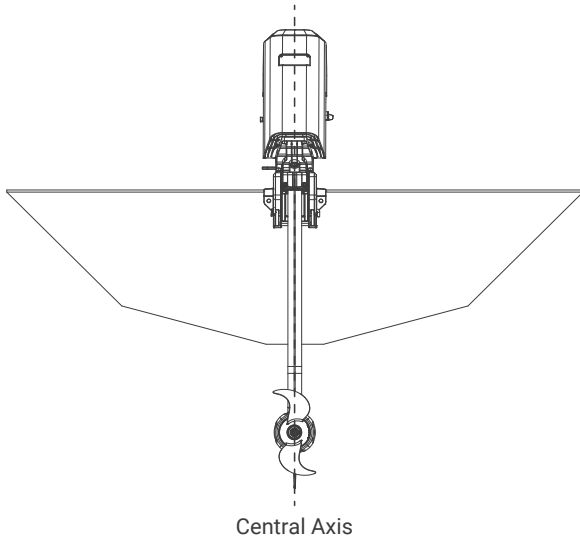

Figure 2-6

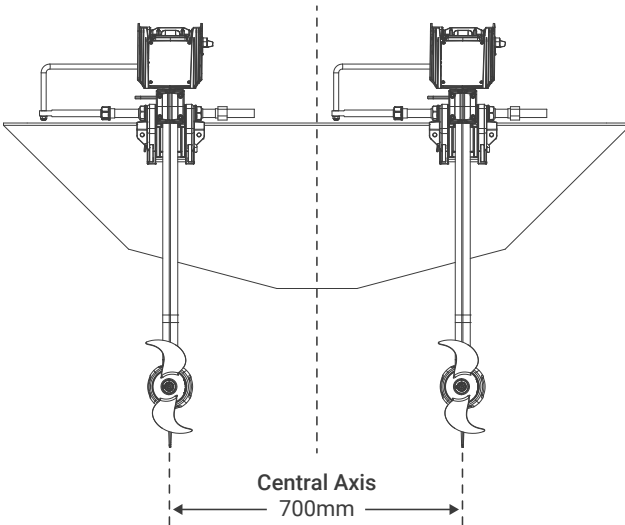

Figure 2-7

2.3 Pitch Angle Adjustment

The Spirit Electric Outboard Motor features adjustable longitudinal tilt to accommodate various boat types. The trim rod offers 4 mounting positions: 0°, 7°, 14°, and 21°. Before normal operation, adjust the trim rod to the appropriate position based on your vessel's specifications.

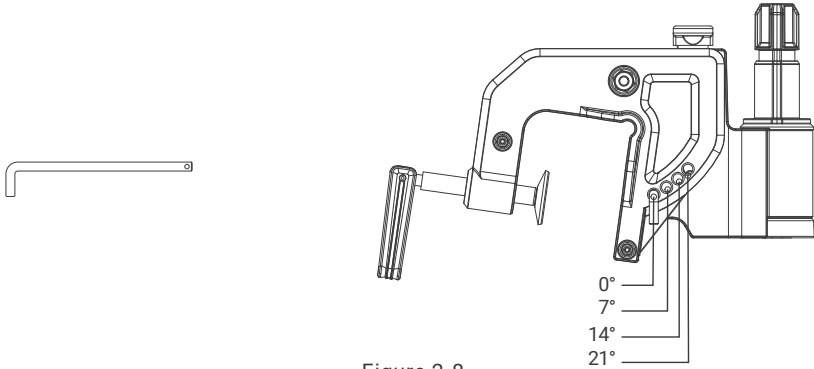

Figure 2-8

2.4 Shallow Water Mode

The Spirit Electric Outboard Motor supports Shallow Water Mode. When cruising in shallow areas, the outboard motor tilts to a fixed angle to activate Shallow Water Mode, enabling the vessel to operate smoothly at a steady speed.



Reverse gear is disabled when in Shallow Water Mode.

Step 1: Lift the tilt release lever upward.

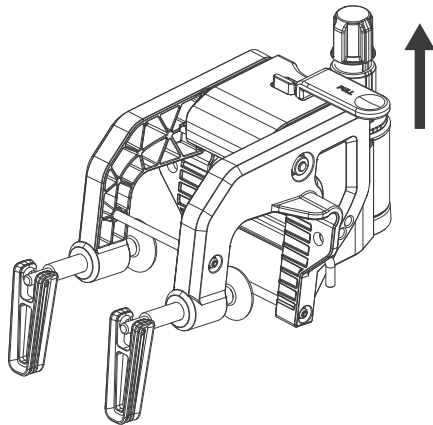

Figure 2-9

Step 2: After tilting the outboard to the shallow water position, release the outboard.

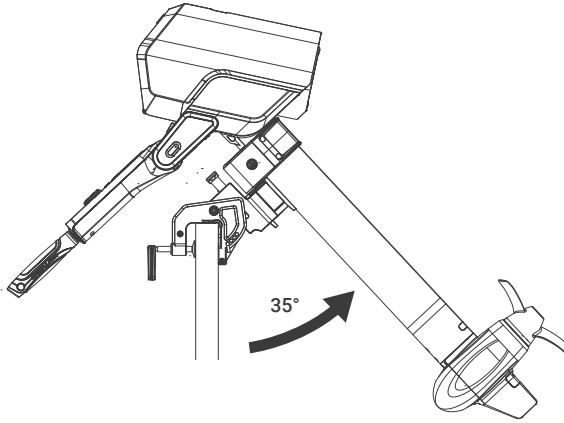



Figure 2-10

2.5 Free Tilt-Up setting

The Spirit Electric Outboard Motor supports Free Tilt-Up setting. When navigating shallow waters with the outboard motor installed, complex underwater conditions may cause collisions or entanglement with aquatic vegetation, potentially disrupting normal operation or damaging the outboard motor. Before navigating complex or unfamiliar underwater terrain, set the outboard motor to Free Tilt-Up setting to protect both the motor and the operator. When in Free Tilt-Up setting, the outboard motor automatically tilts upward upon impact, absorbing the collision force to minimize damage.

 Do not go into Reverse gear in the Free Tilt-Up Setting.

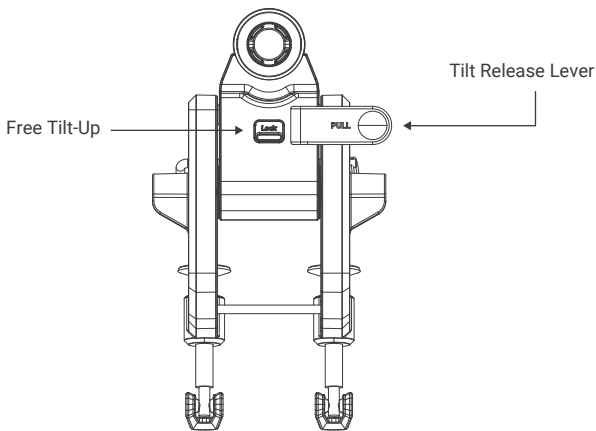

Figure 2-11

Step 1: Pull the lift release lever upward with your right hand to its full extension and hold it in place.

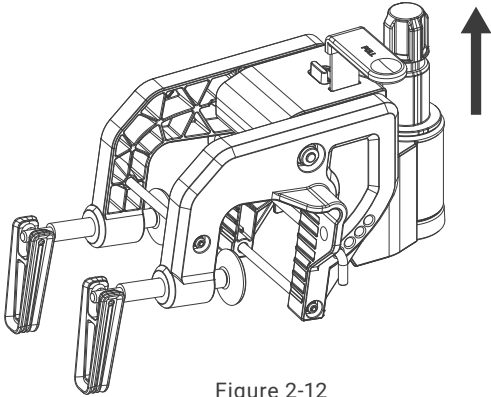

Figure 2-12

Step 2: Push the free tilt-up slider switch forward.

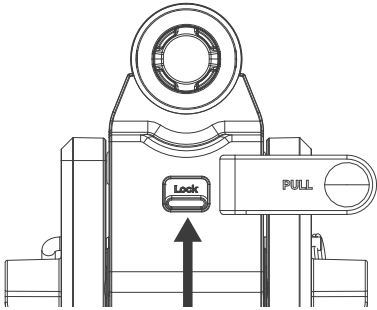

Figure 2-13

Step 3: Release the tilt release lever, and the lever will not retract.

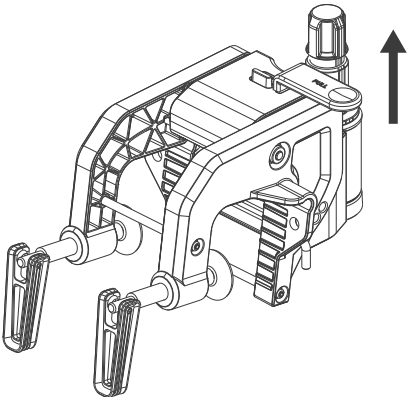

Figure 2-15

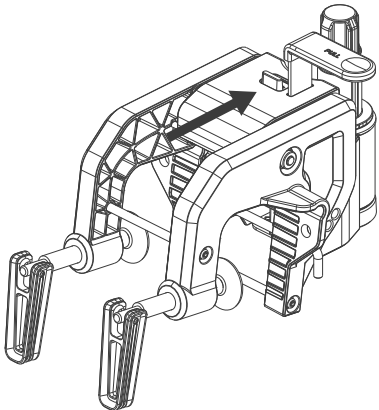

Figure 2-16

2.6 Tilt Up

Outboard Motor Tilt Up

Step 1: Lift the tilt release lever upward;

Step 2: Tilt the outboard motor to 70° or 90°, then release the outboard motor.

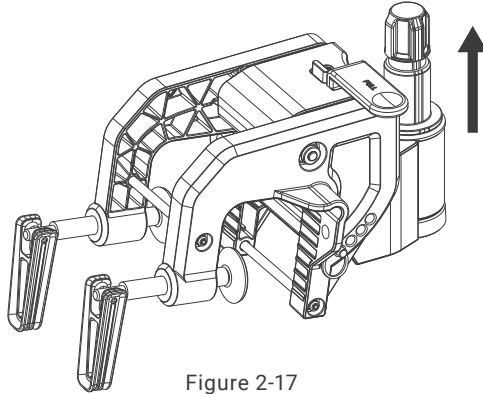

Figure 2-17

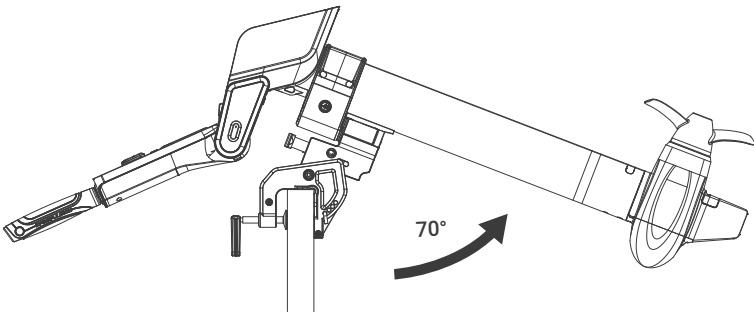

Figure 2-18

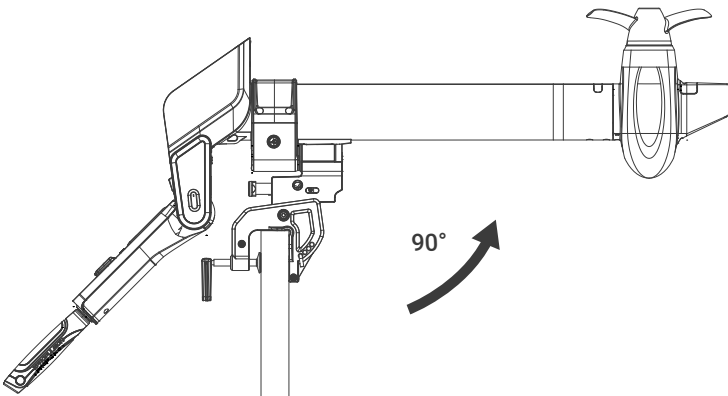

Figure 2-19

Outboard Motor Release

Step 1: Stabilize the motor body with one hand while lifting the lever upward to its fullest extent with the other.

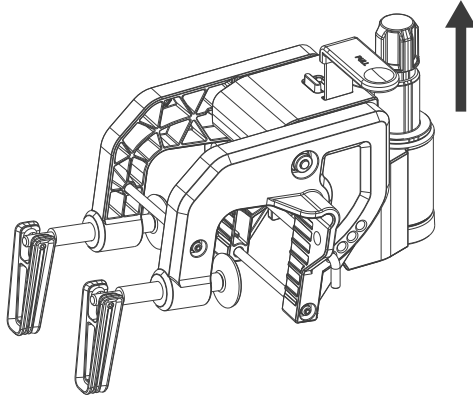

Figure 2-20

Step 2: Slowly return the outboard motor to a vertical position. Ensure the tilt release lever has fully retracted.

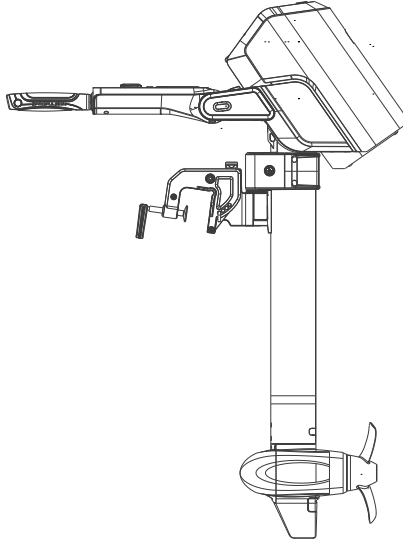

Figure 2-21



Engage the steering lock before tilting to prevent the motor body from tilting sideways after tilting;

2.7 Quick Release

- ⚠️ Ensure the clamp is securely fastened, as loosening may cause the outboard motor to fall into the water or sustain damage.
- ⚠️ Inspect the clamp handle before each use, as mechanical vibration may cause loosening. If the quick-release damping shaft is corroded or salt-encrusted, thoroughly rinse it before reinstalling the entire unit.
- ⚠️ It is recommended to secure the outboard motor to the boat using a rope or chain threaded through the lanyard hole to prevent loss if the outboard motor detaches from the transom.

2.7.1 Quick-Release Installation

- ⚠️ Before installation, extend the tiller.
- Align the quick release mount with the damping shaft and install slowly downward.
- Verify proper seating with no risk of detachment.

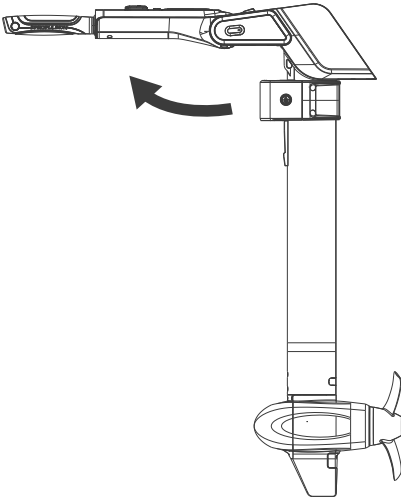

Figure 2-22

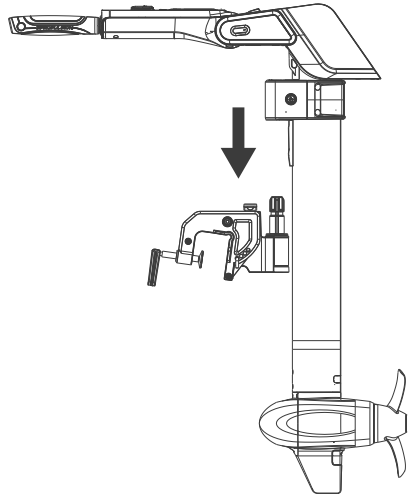

Figure 2-23

2.7.2 Quick-Release Removal

Press the bracket detach button and hold it in the unlocked position without releasing. Slowly lift the unit upward to remove it.

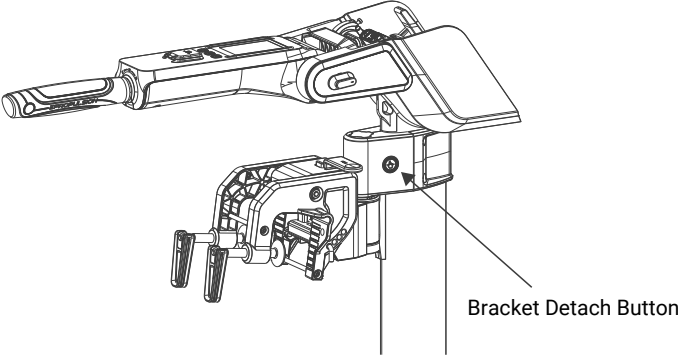

Figure 2-24

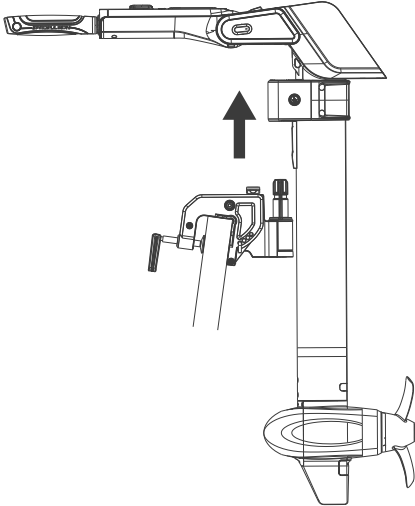

Figure 2-25

2.8 Heading Lock

The Spirit Electric Outboard Motor can lock the outboard motor's forward direction.

Step 1: Push in the steering lock slider switch.

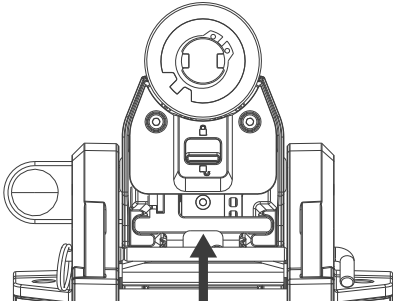

Figure 2-26

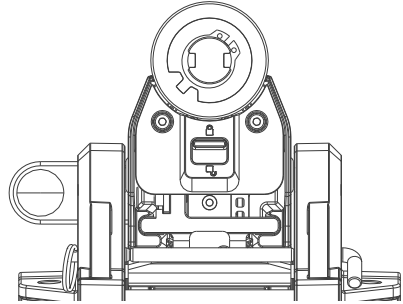

Figure 2-27

Step 2: Rotate the unit left or right near a heading angle of 0° , and automatic locking restricts further steering movement.

2.9 Tiller Pitch Angle Adjustment

The tiller adjusts the tilt angle, operating in either free mode or fixed angles. Free mode allows adjustment between -90° and 80° . Fixed angles offer four lockable tilt angles: -90° , 0° , 45° , and 80° .

2.9.1 Free Mode

Rotate the tiller lock knob 90° to activate free mode, allowing adjustment between -90° and 80° .

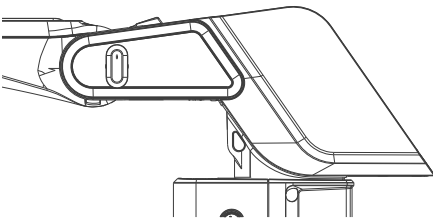

Figure 2-28

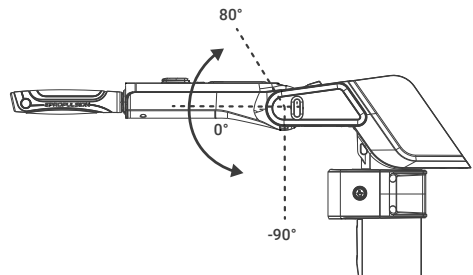

Figure 2-29

2.9.2 Tiller Fixed Angle

Pull outward on the tiller lock knob to lock the tiller into one of four fixed positions: -90° , 0° , 45° , or 80° .

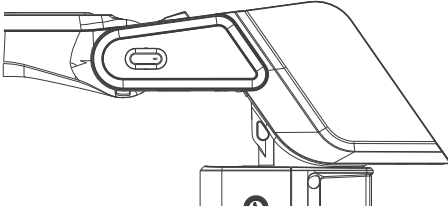

Figure 2-30

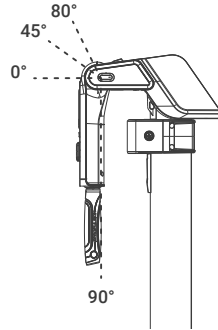

Figure 2-31

The Spirit electric outboard motor supports transporting the outboard motor using the folded tiller. Adjust the tiller to the -90 degree position, and the tiller can serve as the carrying handle for transporting the outboard motor.

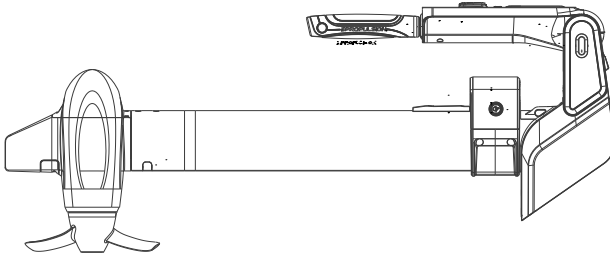







Figure 2-32

-  Ensure the kill switch is removed before transporting the outboard motor.
-  Ensure the motor is turned off before transporting the outboard motor.
-  Ensure the tiller is locked before moving the outboard motor.
-  Do not forcefully swing the outboard motor.
-  Do not extend the handle and pull the outboard motor.

2.10 Extending the Tiller

The tiller incorporates a 13.5cm extension rod. Press the tiller extension button to extend the rod. Once fully retracted, the extension rod locks into place.

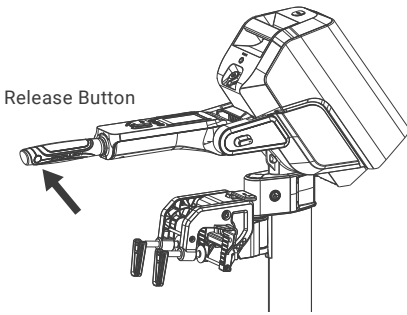

Figure 2-33

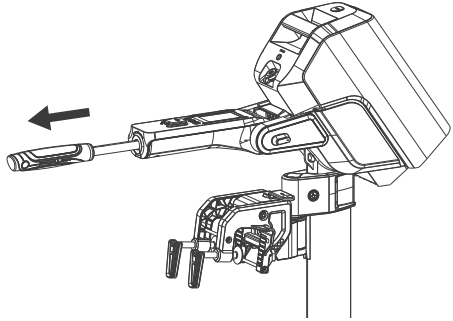

Figure 2-34

2.11 Spirit Battery Installation and Removal

2.11.1 Battery Installation

Step 1: Rotate the battery unlock handle downward to open the protective cover.

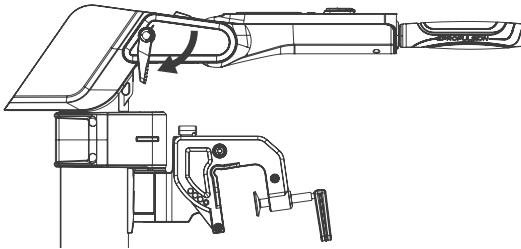

Figure 2-35

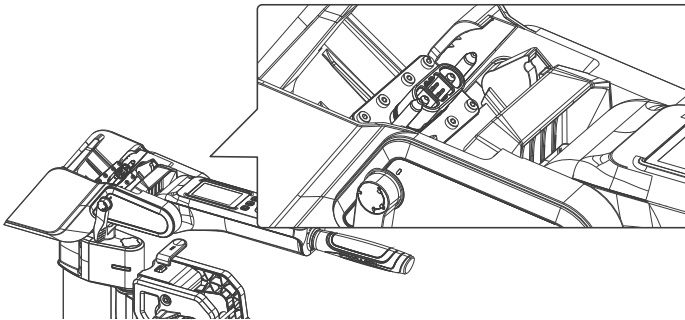

Figure 2-36

Step 2: Insert the battery.

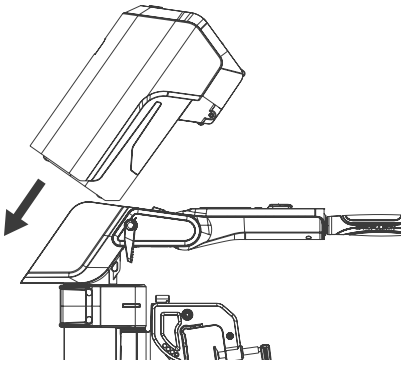

Figure 2-37

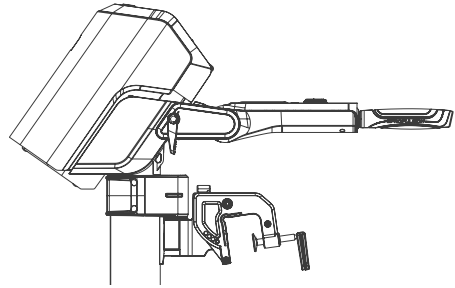

Figure 2-38

Step 3: Rotate the handle upward to secure the battery.

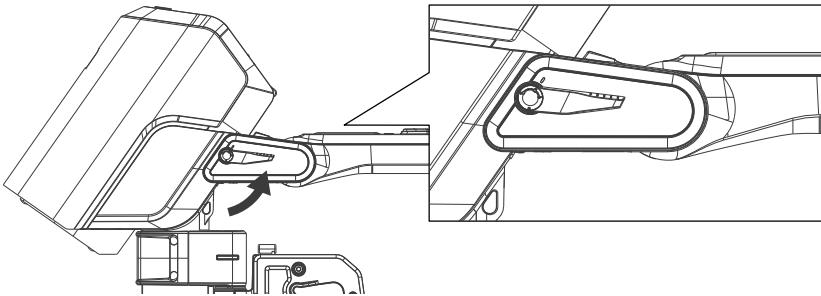

Figure 2-39



Ensure both the device and battery quick release connector are dry during installation to prevent short circuits.

2.11.2 Battery Removal

Step 1: Rotate the handle downward to unlock the battery. This action will push the battery outward.

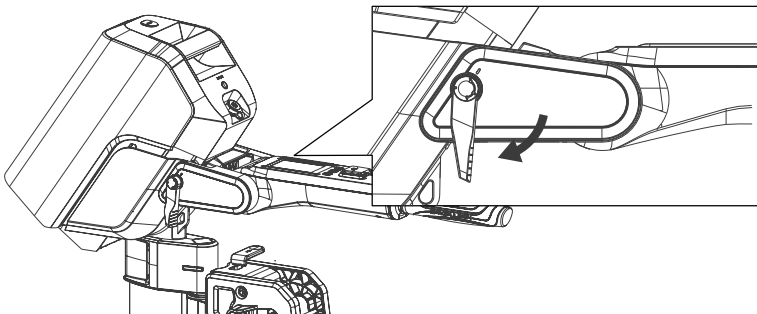

Figure 2-40

Step 2: Pull the battery outward.

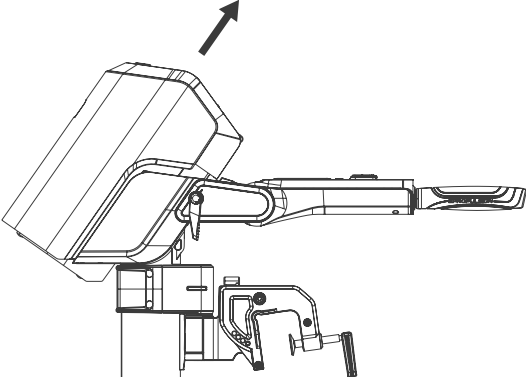

Figure 2-41

Step 3: Rotate the handle upward to close the protective cover.

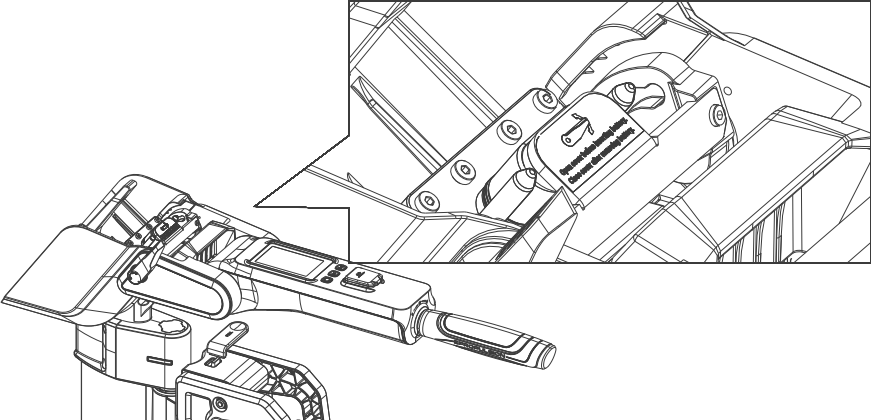

Figure 2-42

2.12 Connecting E-Series Batteries

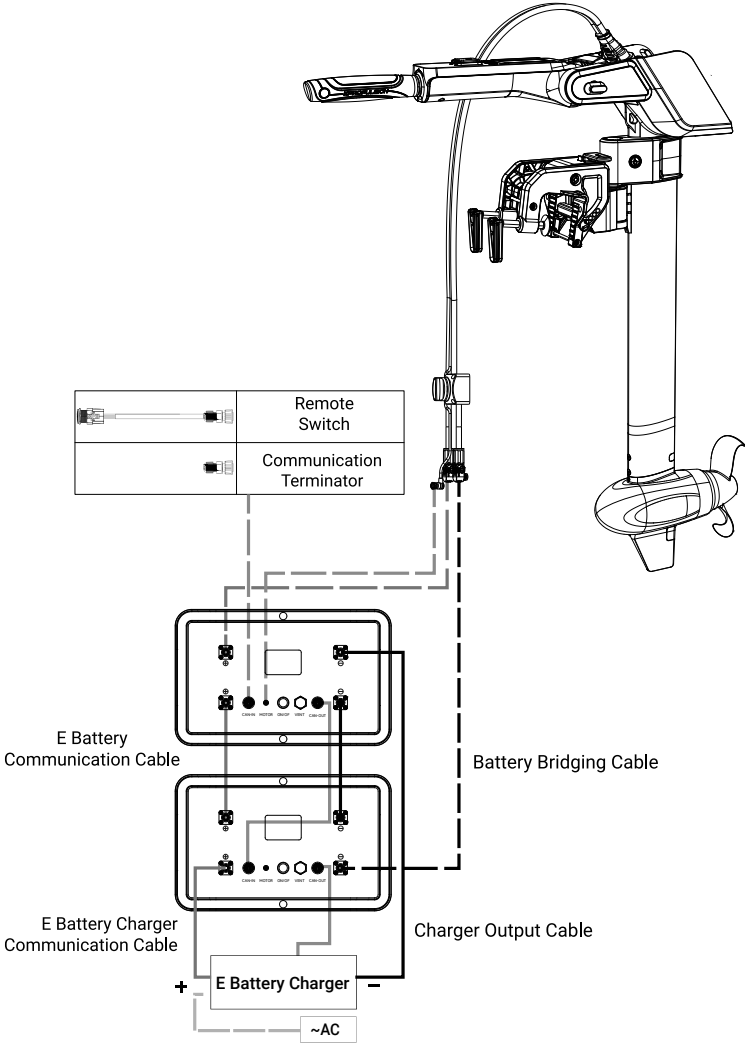

Figure 2-43

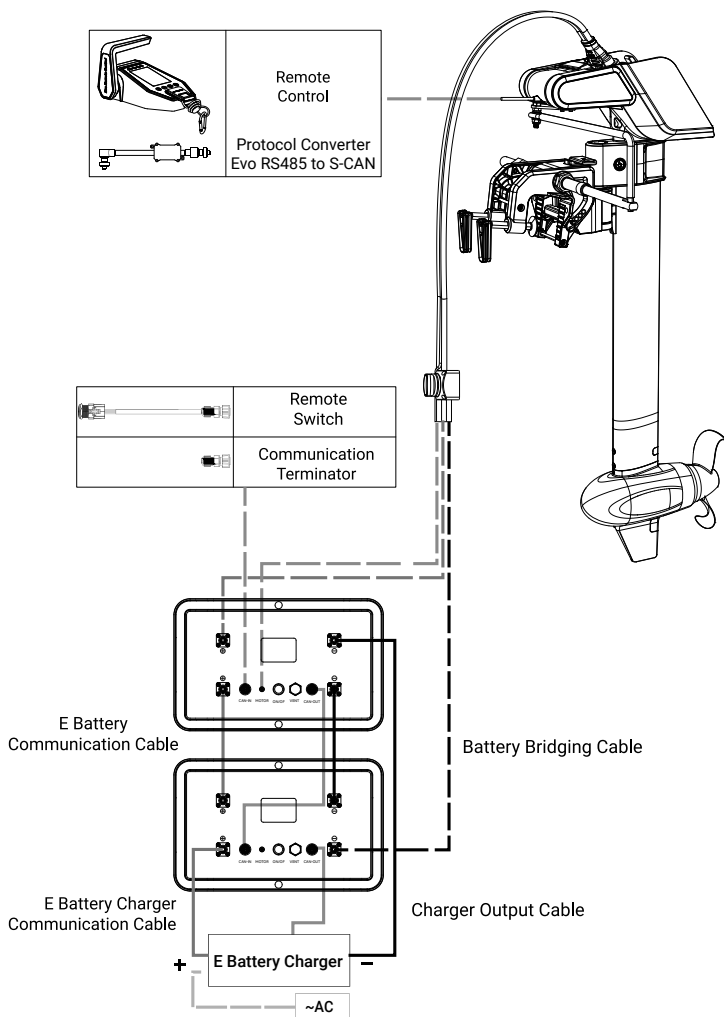

Figure 2-44

- ⚠ Before connecting the 48V ePropulsion E-series battery to the main unit, ensure the battery power switch is turned off.
- ⚠ After completing the wiring harness connection, first close the switch on the wiring harness, then turn on the battery switch, and finally power on the device.

2.13 Extension Cable Installation

Connect the Spirit battery extension cable to the Spirit outboard motor body.

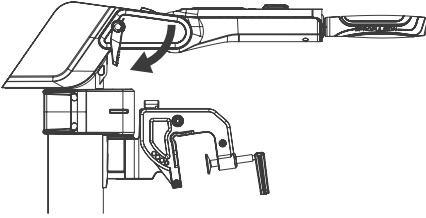

Figure 2-45

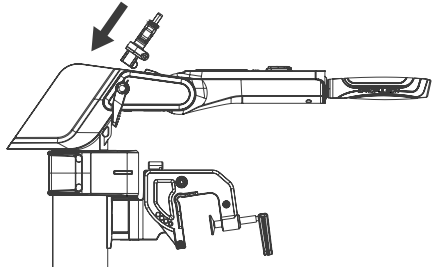

Figure 2-46

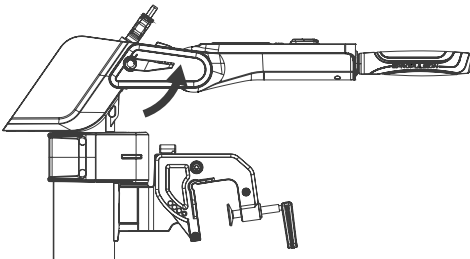

Figure 2-47

Battery installation:

Connect to the Spirit battery

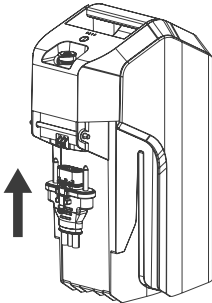

Figure 2-48

Disconnect from the Spirit battery

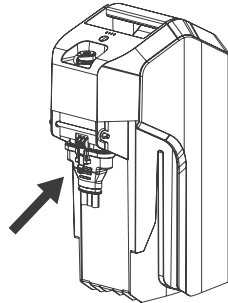



Figure 2-49

Press the locking tab and pull down.

 Spirit Battery Extension Cable Ultra requires separate purchase.

2.14 Lanyard Hole

It is recommended to use a rope or chain through the lanyard hole to secure the outboard motor to the boat, preventing loss if the outboard motor detaches from the transom.

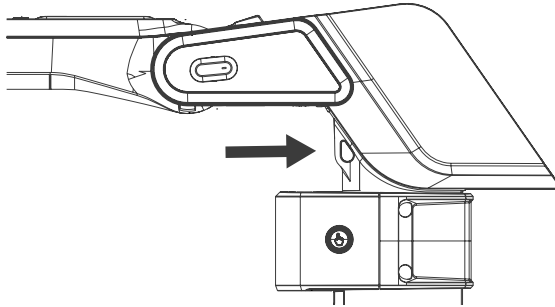

Figure 2-52

2.15 Remote Control Installation

Install remote control steering linkage.

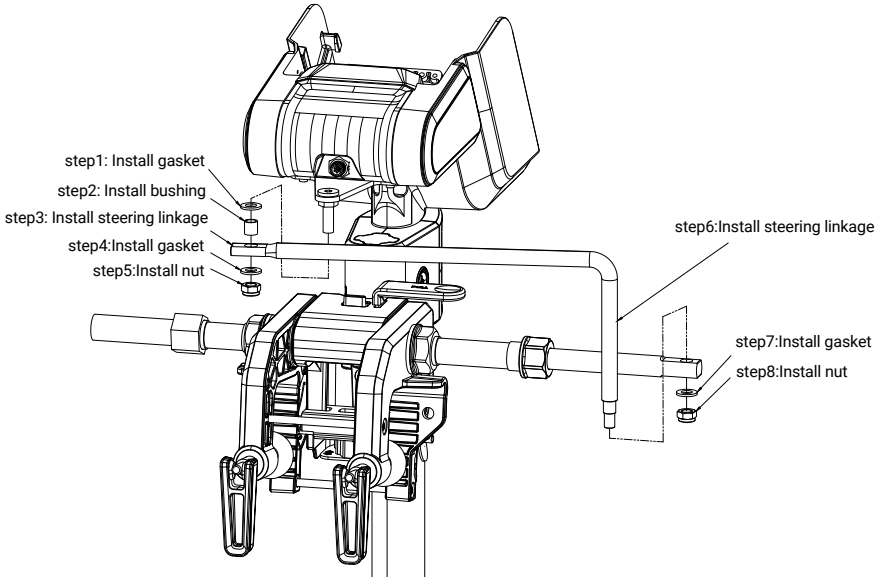

Figure 2-53

2.16 Dual Configuration

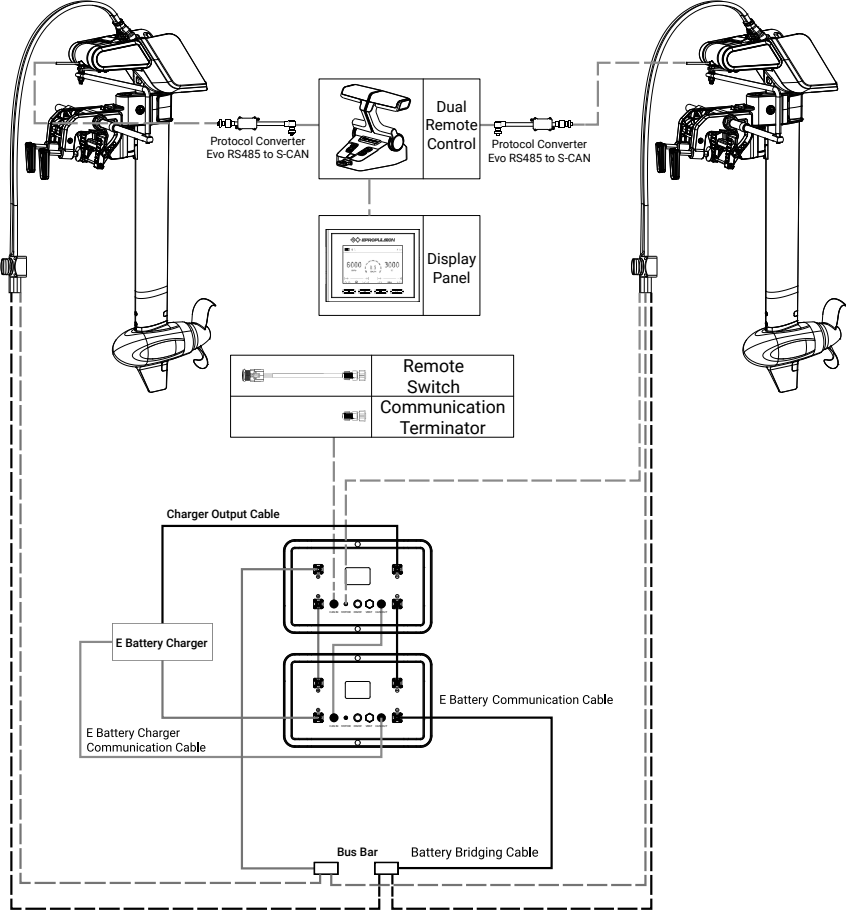

Figure 2-54

3 Tiller Version Operation

3.1 Pre-startup Inspection Items

1. Check if the battery charge is sufficient. Press the battery button to view the remaining charge.
2. Ensure the clamp is securely fastened to the correct position on the transom.
3. Check that the propeller is locked in place.
4. Ensure the throttle is in the neutral position.
5. Ensure the throttle rotates smoothly.
6. Check all connections and wiring harnesses for integrity, signs of aging, or damage.

3.2 Kill Switch

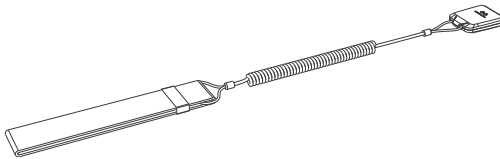

Figure 3-1



For safety reasons, use the kill switch and keep the kill switch lanyard secured to your wrist or life jacket at all times.

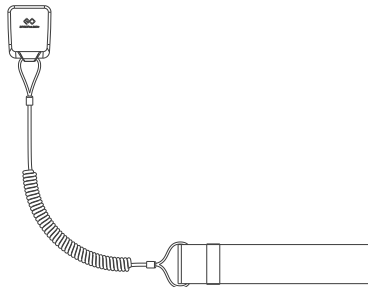



Figure 3-2



Keep the kill switch away (approximately 50 cm) from magnetically sensitive items (such as regulators or medical devices).

3.3 Power On/Off

 Before powering on, ensure the battery is charged.

Press and hold the power button to turn the device on/off.

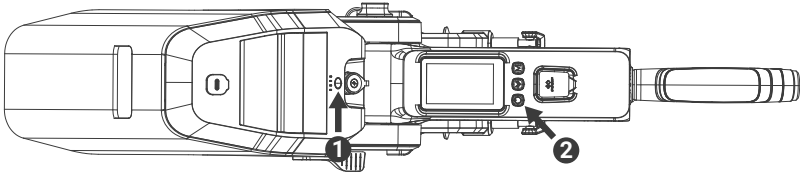



Figure 3-3

 The system will automatically shut down after 30 minutes of inactivity.

3.4 Throttle

Rotate the throttle to adjust power output and switch between forward and reverse gears.

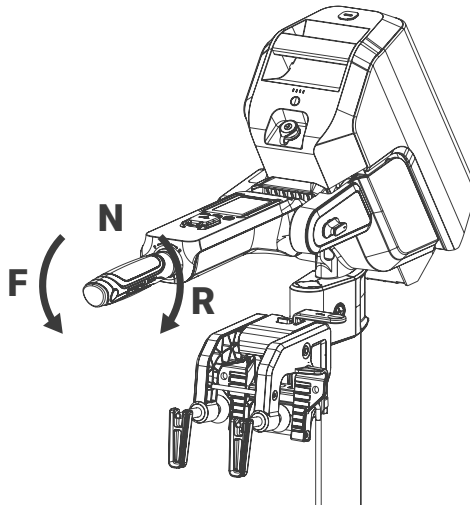

Figure 3-4

3.5 Stopping the Outboard Motor

The outboard motor can be stopped using the following methods.

Method 1: Rotate the throttle to the neutral position.

Method 2: Pull the kill switch.

Method 3: Press and hold the power button.

Method 4: Press and hold the battery button.

Method 5: After unlocking the battery lock, the connector automatically disconnects. (Note: This is an unconventional operation).

3.6 Steering

Steering angle is $\pm 90^\circ$.

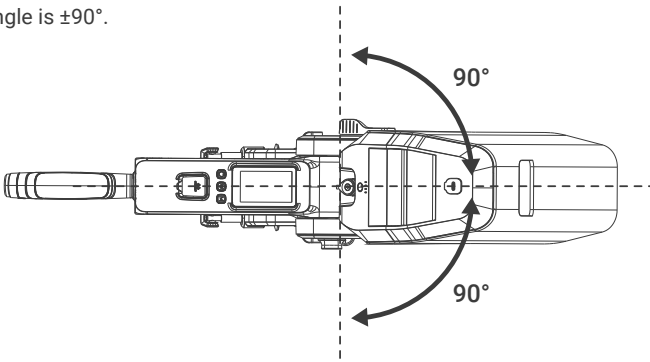





Figure 3-5

3.7 Button Functions

	Power Button	<ol style="list-style-type: none">1. Press and hold to power on/off.2. When setting up the interface, press to return to the previous menu.
	Select Button	<ol style="list-style-type: none">1. In the driving interface, press to toggle between power and speed displays.2. In the settings interface, press to switch between options and adjust parameters.
	M Button	<ol style="list-style-type: none">1. Long press to enter/exit settings menu.2. In the driving interface, press to enter/exit Boost mode.3. In the settings interface, press to enter/exit editing; long press to return to the previous level.

3.8 Main Interface

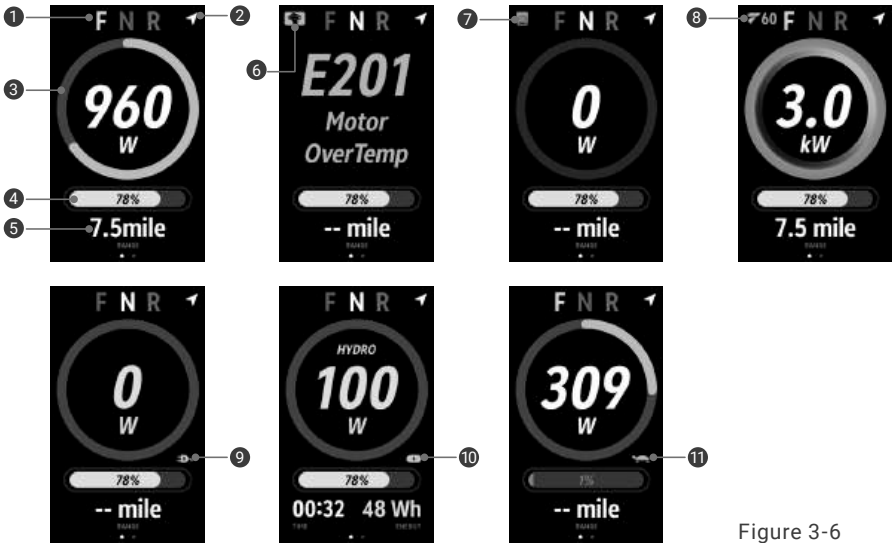











Figure 3-6

No.	Feature	Description
1	 Gear	F: Forward gear N: Neutral R: Reverse gear
2	 GPS Status	Icon flashes when not located, remains steady when located, and changes to yellow.
3	Power/Speed	Press  to toggle between power and speed display. Speed cannot be displayed when no position is acquired or when GPS is malfunctioning.
4	Battery Level	Displays current battery level.
5	Remaining Distance	Calculates and displays remaining range in real-time based on current battery level and speed. Units can be switched in the settings interface.
6	 Error Icons	Displays corresponding fault icons when issues occur with the system, battery, motor, or throttle.
7	 Kill Switch	The icon flashes when the kill switch is detached. It remains constantly displayed when the system is in kill switch override mode (loss mode).

No.	Feature	Description
8	 Boost Mode	When in F or N gear, press M once to enter/exit Boost mode. Upon successful entry, the icon remains lit with a countdown displayed.
9	 Charging icon	Display during charging
10	 Hydrogeneration icon	Display during hydrogeneration
11	 Turtle Light Icon	Battery power is depleted. The device has entered low-power limp mode. Please return to shore at low speed as soon as possible.

3.9 Boost Mode



Figure 3-7

With sufficient battery charge (see Section 3.20), no errors, and gear in F or N, press **M** to enter Boost mode. Power output increases by 1.5 times and lasts for 60 seconds. Press the **M** to manually exit the mode. Boost Mode will automatically exit when the battery is low, a fault occurs, or the gear is switched to R (Reverse).

3.10 Settings Page



Figure 3-8

1. Long press **M** to enter settings menu.
2. Press **M** to enter option.
3. Press  to toggle option.
4. Long press **M** to exit settings menu.

3.11 Dark Mode

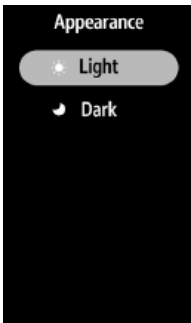

Figure 3-9

1. Click **M** to enter the theme switching options.
2. Click **⌵** to switch between Day and Night modes.
3. Click **M** to confirm, and the system will automatically return to the settings menu.

3.12 Brightness

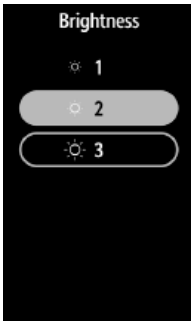



Figure 3-10

1. Click **M** to enter the brightness adjustment options.
2. Click **⌵** to select a brightness level, with Level 1 being the dimmest and Level 3 the brightest.
3. Click **M** to confirm, and the system will automatically return to the settings menu.

 Level 1 brightness is suitable for use in dark environments.

3.13 Unit Settings

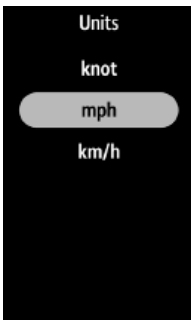

Figure 3-11

1. Click **M** to enter the unit settings option.
2. Click **⌵** to select the unit.
3. Click **M** to confirm, and the system will automatically return to the settings menu.

3.14 Software and Hardware Versions



Version		
Name	Software	Hardware
S-ECU	V1.05	V1.0
BMS	V2.01	V1.2
Tiller	V1.03	V2.0
MCU	V1.05	V1.6

Figure 3-12

1. Click **M** to enter the version query options.
2. Click **M** to return to the settings menu.

3.15 Usage Data



Data
Total Operating Time
999.9hrs
Total HYDRO Energy
888 Wh

Figure 3-13

1. Click **M** to access the data query options and view cumulative runtime and cumulative hydrogeneration energy.
2. Click **M** to return to the settings menu.

3.16 Third-Party Battery Settings

When using third-party batteries, you can set the maximum and minimum voltage for under-voltage and over-voltage protection.



Battery
Click M Button to edit
MAX 56.0 V
MIN 36.0 V
Voltage protection limit
ON
OFF
Long press M Button to back

Figure 3-14

1. Click **M** to enter third-party battery settings.
2. Click **⌵** to select to set maximum or minimum voltage.
3. Click **M** to begin setting maximum or minimum voltage.
4. Click **⌵** to adjust maximum or minimum voltage value. Each click adjusts by 1V.
Maximum voltage range: 46V – 58V.
Minimum voltage range: 36V – 45V.
5. Click **M** to confirm voltage settings.
6. Click **⌵** to select to enable or disable this feature.
7. Click **M** to confirm enabling or disabling this function.
8. Press and hold **M** to return to the settings menu.

 Please use third-party batteries with pre-charging capability (pre-charge current $\leq 30A$).



 After completing the wiring harness connection, first close the switch on the wiring harness, then turn on the battery switch, and finally power on the device.

3.17 Kill Switch Override Mode

When the kill switch is lost, you can activate the emergency safety loss mode. In this mode, the maximum allowable motor output power is 50% of the rated power. The system automatically exits the kill switch override mode after shutdown.



Figure 3-15

1. Click  to enter the kill switch options.
2. Click  to select enabling or disabling the kill switch override mode.
3. Click  to confirm, and the system will automatically return to the settings menu.

3.18 Hydrogeneration

The outboard motor features a hydrogeneration function. When in hydrogeneration mode, the main interface displays the hydrogeneration icon, hydrogeneration duration, and power generation output.



Figure 3-16

The motor enters hydrogeneration mode when the following conditions are met:

1. The throttle is in neutral (N) position.
2. Battery charge level is below 90%.
3. The boat travels steadily at 6 km/h or the propeller speed exceeds 400 rpm for 3 seconds.

4. The hydrogeneration function is only available when connected to a ePropulsion battery.
5. If connecting an E-series battery, the communication cable must be connected.

Hydrogeneration will stop under any of the following conditions:

The throttle is in F or R gear.



The boat is not moving or traveling too fast (above 30 km/h), or the propeller speed exceeds 2400 rpm.

Battery charge level exceeds 90%.



 When the boat speed exceeds 35 km/h or the propeller speed exceeds 2800 rpm, the outboard motor must be lifted.

 Only "Spirit Battery Ultra" and "E Series Battery" support hydrogeneration; (Contact your dealer to confirm compatibility before installing E Series Battery)

3.19 Errors

Figure		Function / Description
	Battery Error	When the remaining battery level drops below 10%, the system enters power-limiting mode. The maximum power output is dynamically adjusted based on the remaining battery level.
	Motor Error	Outboard motor malfunction triggers power-limited mode, with maximum power restricted to 50%.
	Other Error	Other outboard motor errors occur, entering power-limited mode with maximum power restricted to 50%.
Error Code EXXX	Critical error	The outboard motor has experienced a critical error and has stopped operating.

Error Code	Figure	Troubleshooting
E201 E202 E403 E412	<p>Overtemperature</p> 	<p>Stop using the outboard motor and allow it to cool down. If the issue persists, contact an authorized ePropulsion dealer.</p>

Error Code	Figure	Troubleshooting
E207 E313 E400 E401	<p>Low Battery</p> 	Stop using and charge. If the issue persists after restarting, contact an authorized ePropulsion dealer.
E210	<p>Propeller Blocked</p> 	Check if the outboard motor propeller is entangled. If the issue persists after clearing the entanglement, contact an authorized ePropulsion dealer.
Other	/	Stop using the device and restart it to see if it functions normally. If the issue persists, please contact an authorized ePropulsion dealer.

3.20 Battery Level Alert and Power Reduction Strategy

Under normal ambient temperatures (10°C to 50°C), the maximum motor output power at different battery levels is as follows.

(SOC%) / Mode	Standard Mode	Boost Mode
[30 - 100]	2000W	3000W
[20 - 30)	2000W	2500W
[10 - 20)	1000W	Not Supported
[1 - 10)	500W	
[0 - 1)	250W	

When the remaining battery level reaches 50% and 10%, the outboard motor will alert you via a buzzer.

3.21 Throttle Calibration

When throttle malfunctions, manually calibrate the throttle.

Step 1

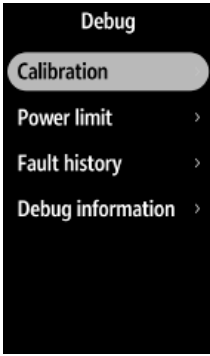

Figure 3-17

1. Press and hold **M** and **⌵** simultaneously to enter the hidden interface.
2. Click **M** to access the throttle calibration options.

Step 2



Figure 3-18

1. Click **M** to begin calibration.

Step 3

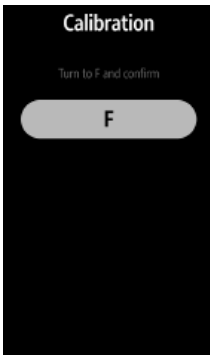

Figure 3-19

1. After rotating the throttle lever to the maximum position in F gear, click **M** to confirm.
After rotating the throttle lever to N gear, click **M** to confirm.
2. After rotating the throttle lever to the maximum position in R gear, click **M** to confirm.

Step 4



Figure 3-20

1. A prompt will indicate calibration success or failure.
2. Press and hold **M** to return to the settings menu.

3.22 Power Limit Setting

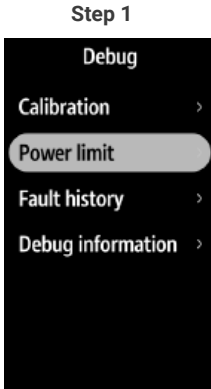

Figure 3-21

1. Press and hold **M** and **↙** simultaneously to enter the hidden interface.
2. Click **↙** to switch to the power limit options.
3. Click **M** to enter the power limit options.

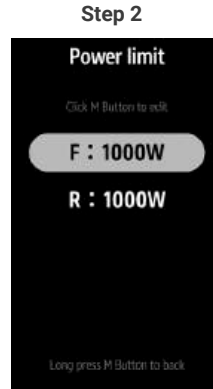

Figure 3-22

1. Click **↙** to select setting power limits for F-gear or R-gear.
2. Click **M** to confirm the power limit setting for F-gear or R-gear.

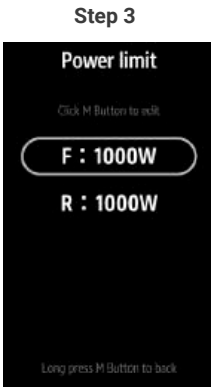

Figure 3-23

1. Click **↙** (or twist the throttle grip) to adjust the power limit value within the range (100~2000 W).
2. Click **M** to confirm the set value.

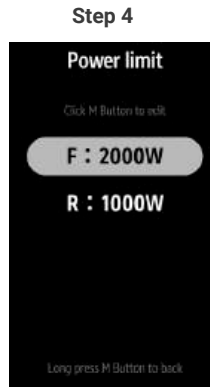

Figure 3-24

1. Press and hold **M** to return to the settings menu.



Unable to enter Boost mode after power limitation.

4 Remote Version Operation

The Evo Remote Control is used to start and stop the outboard motor, adjust speed, configure battery parameters, display system information, and more. The Evo Remote Control can be powered by solar energy or its built-in lithium battery. The Evo Remote Control communicates with the outboard's built-in communication system via wired connection. The Evo Remote Control requires an external steering wheel for steering assistance.

4.1 LCD Display

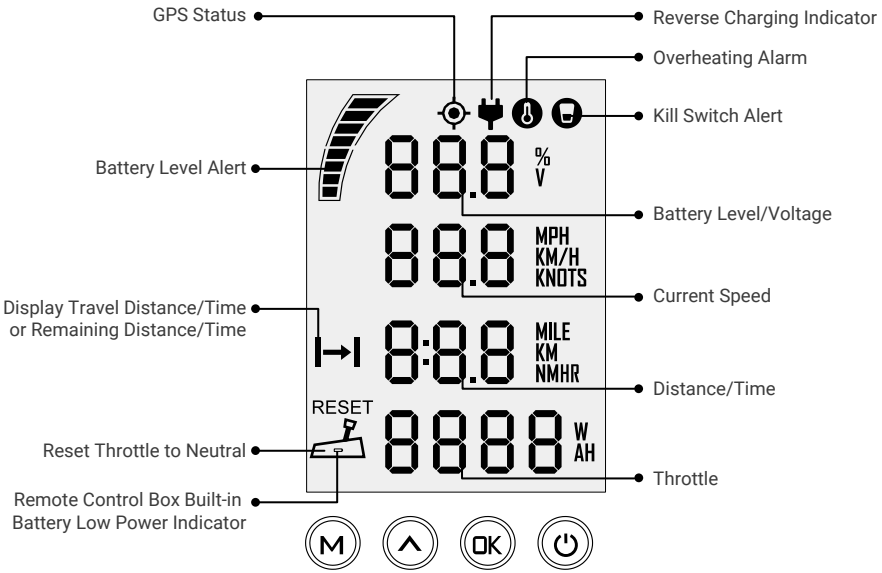

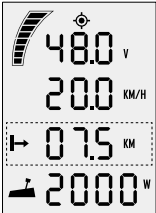

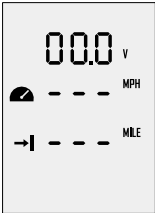
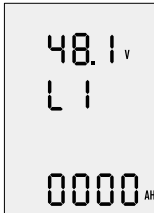







Figure 4-1

Buttons	Functions
 "Power"	<ol style="list-style-type: none"> 1. With the power off, press and hold the power button for a moment to activate the Evo Remote Control. 2. With the power on, press and hold the power button for a moment to deactivate the Evo Remote Control. 3. With the power on, press the power button to turn the backlight on or off.



Buttons	Functions	
<p>OK "OK"</p>	<ol style="list-style-type: none"> 1. On the settings page, press the "OK" button to save the current settings and switch to the next item. 2. On the settings page, press and hold the "OK" button for a moment. The system will save the current settings, exit the settings page, and return to the main page. 3. On the main screen, press the "OK" button to toggle between displaying voltage (V) and battery percentage (%). 	
<p>^ "Select"</p>	<ol style="list-style-type: none"> 1. On any settings page, press the "^" button to view options for the current setting. 2. With power on and the home page displayed, press and hold the "^" button for 10 seconds to enter the throttle calibration page. 3. On the main page, press the "^" button to toggle between displaying navigation distance or time icons. 4. Press the "^" button to navigate between Home Page 1 and Home Page <div style="display: flex; justify-content: center; align-items: center; gap: 20px;"> <div style="text-align: center;">  <p>Home Page 1</p> </div> <div style="font-size: 2em;">→</div> <div style="text-align: center;">  <p>Home Page 2</p> </div> </div>	
<p>M "Menu"</p>	<ol style="list-style-type: none"> 1. With the power on and displaying the home page, press and hold the "M" button briefly to enter the preferences page. <div style="text-align: center;">  <p>Battery Settings Page</p> </div>	<ol style="list-style-type: none"> 2. On the Reference Settings page, press and hold the "M" button for a moment to enter the Battery Settings page. <div style="text-align: center;">  <p>Battery Settings Page</p> </div>
<ol style="list-style-type: none"> 3. From any page, press the "M" button to return to the main page. 		



If the user accesses this page without setting any parameters, the current parameters displayed on the page will be saved as user parameters under default conditions.

Icons	Functions	
	Current Speed	Displays instantaneous cruising speed. Units can be set on the Preferences page (mph, km/h, or knots).
	Distance/Time Display	Displays instantaneous sailing distance. Units can be set on the Preferences page (miles, kilometers (km), and nautical miles). Time is measured in hours.
	Range/ Remaining Range	→ : Remaining range or runtime. → : Distance or time traveled. Units can be set on the Preferences page (miles, kilometers, or nautical miles). Time is measured in hours.
	Throttle Power	Displays the system's current input power. Flashing "RESET" indicates the throttle needs to be returned to neutral.
	Reverse Charging Indicator	Solid display: Reverse charging function is enabled. Flashing: The unit is charging the battery.

4.2 Power Adjustment

-  Place the kill switch on the Evo Remote Control before operation.
-  The Evo Remote Control primarily adjusts the input power to the outboard motor. With the battery properly connected, turn on the Evo Remote Control to start the outboard motor. Slowly push the throttle to the forward position and gradually increase throttle power. Refer to the table below for maximum forward/reverse power ratings.
-  When "RESET" flashes on the LCD display, return the throttle to neutral.

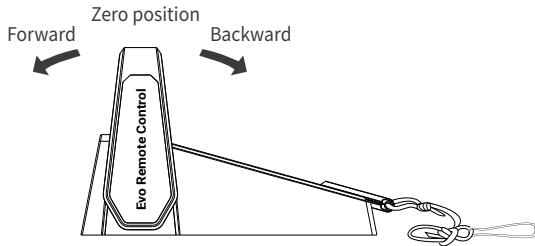



Figure 4-4



4.3 Calibration



If the error codes shown in Figures 4-5 appear, strictly follow the calibration procedure below to calibrate the throttle.



Figure 4-5

-  Before calibration, place the supplied kill switch in the designated position. Do not use any other magnet to replace the kill switch for calibration.

Recalibration process	LCD Displaying
<p>Step1: Long press “” button for 10s until “CAL FO” displays.</p>	

Recalibration process	LCD Displaying
<p>Step2: Push the throttle to the maximum forward power position, then press "OK" button. "CAL 5t" will display and "CAL" will be blinking.</p>	
<p>Step3: Pull the throttle to the middle (zero) position where you can hear a click sound, then press "OK" button, "CAL bA" will display and "CAL" will be blinking.</p>	
<p>Step4: Pull the throttle to the maximum backward power position, then press "OK" button. It will return to the main page automatically.</p>	

4.4 Using the kill switch

Attach the kill switch lanyard to your wrist or life jacket.

In an emergency, pull the kill switch to stop the outboard motor.

Before restarting the motor, ensure the kill switch is properly secured and engaged.

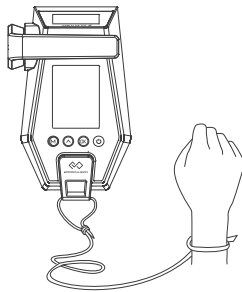

Figure 4-5



The kill switch generates a magnetic field. Therefore, keep it at least 50 cm away from medical implants, magnetic cards, and other magnetic media.



The magnetic field from the kill switch may interfere with certain electronic instruments. Therefore, keep it away from electronic instruments.

4.5 Warning Messages

When the outboard motor experiences abnormal operation or malfunctions, warning messages with error codes will appear on the display screen, accompanied by a continuous beeping sound from the Evo remote control. The table below assists in locating solutions. Refer to the table for additional error codes and corresponding troubleshooting methods.

Code	Cause	Solution
E01	Battery voltage is outside the operating range	Replace the battery according to the recommended operating procedures.
E02	Propeller blockage causing excessive drive current	Refer to the solution for E10.
	Drive failure due to excessive current	Attempt to turn off the main switch and wait 10 seconds, then turn the switch back on.
E03	Other serious malfunctions	Please contact an authorized ePropulsion dealer.
E06	Battery voltage too low	Even if this warning message disappears automatically, the outboard may still operate at reduced power. Charge the battery as soon as possible.
E10	Possible motor stall due to propeller obstruction	Turn off the main switch, then remove any objects entangled in the propeller. Test whether the propeller can be rotated by hand. If so, the outboard motor can be restarted.
E11	Motor overheating	Stop the outboard motor and wait until the temperature drops to within the normal operating range.
E12	Circuit board overheating	Stop the outboard motor and wait until the temperature drops to within the normal operating range.
E22	Internal MCU communication error	Restart to check if normal. If the issue persists, contact an authorized ePropulsion dealer.
E30	Throttle position sensor malfunction; throttle recalibration required	Refer to Section 4.4 "Calibration" for throttle recalibration procedures.

Code	Cause	Solution
E60	Evo Remote Control Power Depleted	Connect the Evo Remote Control to the outboard motor using the communication cable. Refer to Section 4.2.2 "Charging via Wired Connection".
All characters display	Outboard Motor Power Supply Abnormal	Connect the battery to the outboard motor, then turn on the main Display switch.
	Communication anomaly between the Evo remote control and the outboard motor	Check whether the communication cable between the remote control and the engine is functioning properly.

 If the issue persists, please contact an authorized ePropulsion Technology dealer for assistance.

4.6 Configuration

It is recommended to set display preferences following these steps before using the Spirit Electric outboard motor.

Step1: With the unit powered on, press and hold the “**M**” button for 2 seconds to enter the preferences page, as shown in Figure 4-9. Users can select display items based on personal needs and preferences.



Figure 4-9

Step2: On the “Preference Settings” page, flashing items indicate those ready for configuration. Press the “**^**” button to view additional options for the flashing item. For example, in Figure 6-1, if “**V**” flashes on the preference settings page, it means “**V**” has alternative options. Simply press the “**^**” button, and “**V**” will switch to “**%**”, indicating a change from voltage display to battery level display.



Step3: Press the “**OK**” button to save the current item's setting, and the system will automatically move to the next item.

Step4: Once all items have been set, press and hold the “**OK**” button to save all settings and return to the home screen.

4.7 Battery Configuration

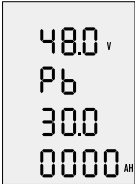
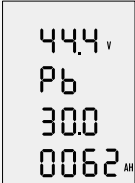
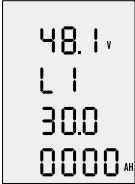
Accurate battery configuration enables precise assessment of the battery's state of discharge. When using non-communicative batteries, users should manually configure the battery via the Evo Remote Control during initial use to ensure more accurate battery level display.

Battery Configuration Procedure	LCD Displaying
<p>Step1: Turn on the main switch and wait for the Evo Remote Control to enter the main page.</p> <p>Simultaneously press and hold the " M " and " OK " buttons for a moment to enter the battery settings page. The battery type will flash, indicating it is ready for configuration.</p>	
<p>Step2: Select the battery type based on the battery you are using. Press " OK " button to cycle through the battery type options: Pb, Li, and LFE.</p> <p>Pb: Lead-acid battery Li: Lithium battery LFE: Lithium iron phosphate battery</p>	
<p>Step3: Press the " ^ " button to save the battery type setting and return to the battery rated voltage setting item. Voltage options are provided based on the battery type. Press the " OK " button to view these options and select the closest rated voltage value for your battery.</p>	

Battery Configuration Procedure	LCD Displaying
<p>Step4: Press the “▲” button to save the current settings and move to the battery capacity setting item.</p> <p>Press the “OK” button to select the battery capacity based on the battery you are using. Set the four digits sequentially from left to right. After setting each digit, press the “▲” button to move to the next digit.</p> <p>Capacity is measured in “ampere-hours” (Ah). While battery capacity is commonly expressed in “watt-hours” (Wh), Ah capacity is derived using the following formula:</p> <p>Capacity (Ah) = Capacity (Wh) / Rated Voltage (V)</p> <p>Example: A 3000Wh lithium battery with a rated voltage of 48.1V has an approximate capacity of 62.37Ah. This can be set to 62Ah.</p>	
<p>Step5: Press the “M” button to save and complete the battery settings. The display will return to the main page.</p>	

 When using the batteries listed below, configure the battery type and corresponding voltage values according to the parameters in the table.

Battery type	Nominal Voltage options
Lithium Battery	43.2V 44.4V 45.6V 46.8V 48.1V 49.4V 50.4V 51.8V 53.2V
Lead-Acid Battery	44.0V 46.0V 48.0V 50.0V 52.0V 54.0V
Lithium Iron Phosphate Battery	44.8V 48.0V 51.2V

 To use a different battery type, battery configuration must be updated.

 When using non-ePropulsion Technology E-series batteries for the first time, manually configure the battery via the Evo Remote Control to ensure more accurate battery level display.

5 Emergency Operation

5.1 Impact Damage

If the outboard motor sustains an unexpected underwater impact while operating, take the following actions:

1. Shut down the motor immediately.
2. Inspect the outboard motor's mechanical components for damage and verify that the control system functions normally.
3. Proceed cautiously and slowly to the nearest dock or shore.
4. Contact your authorized ePropulsion Technology dealer for inspection and repair. Ensure the outboard motor passes inspection before using it again.

5.2 Outboard Motor Accidental Submersion

If the outboard motor accidentally falls into the water during operation, take the following actions:

1. Immediately shut off the motor and disconnect the power source after recovery.
2. Contact your authorized ePropulsion Technology dealer for inspection and repair. Ensure the motor passes inspection before using it again.

6 Transportation and Storage

6.1 Transport

For long-distance transport, use the original factory packaging provided when shipping the outboard motor.



Strictly adhere to national and local regulations when carrying or transporting batteries.



Do not transport damaged or abnormal lithium batteries.

6.2 Storage

For extended storage (over 2 months), It is recommended to perform maintenance as outlined in Chapter 7 and thoroughly rinse the outboard motor before storage to prevent corrosion caused by seawater. Then pack the outboard motor using the original factory packaging provided before long-term storage. Always implement shock absorption and protective measures before transporting or storing the outboard motor.



During transport and storage, ensure the outboard motor is kept in a horizontal position.





Store the outboard motor in a dry, well-ventilated area away from direct sunlight.

7 Maintenance and Care



7.1 Important Notes

Regular maintenance keeps your outboard motor operating at peak performance and extends its lifespan.

After use in saltwater, promptly rinse with fresh water to minimize corrosion.

-  Always perform maintenance or repairs with the outboard motor's power source turned off.
-  Repairs must be conducted under the guidance of a professional or authorized dealer.
-  If any parts of the outboard motor are damaged or require replacement, use only genuine ePropulsion Technology parts.

7.2 Propeller Maintenance

-  Always disconnect the outboard motor's power source before inspecting, removing, or installing the propeller to prevent accidental startup. Failure to do so may cause serious injury to the operator or nearby personnel.
-  Do not touch the propeller directly with your hands during operation. Wear protective gloves to prevent injury.

Follow the propeller inspection steps below. Refer to the diagram for propeller removal and replacement procedures.

1. Inspect the propeller blades for wear and corrosion.
2. Inspect the propeller mounting shaft and hole for damage, and check the drive pin for wear.
3. Remove any debris entangled on the propeller (e.g., fishing nets, fishing lines, aquatic plants, etc.).
4. Inspect the oil seal cover plate for any debris wrapped around it and remove it.

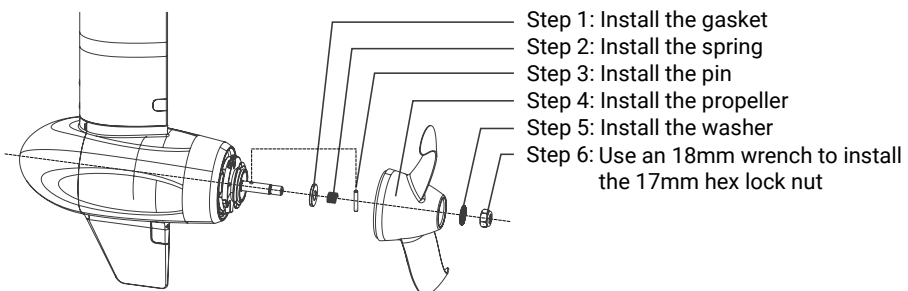

Figure 7-1

7.3 Replacing the Anode

If an anode replacement is required, refer to the diagram below to install a new anode.

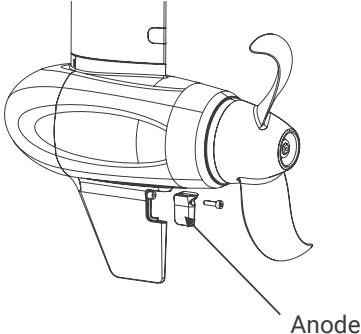

Figure 7-2

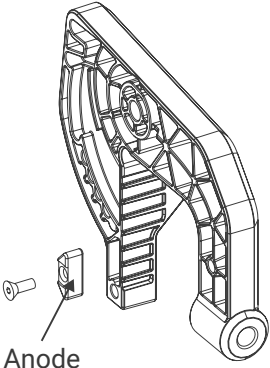

Figure 7-3

7.4 Maintenance of Electrical Contacts

Clean all electrical contacts with contact cleaner every two months. Clean immediately if rust appears.

7.5 Lubricating the Outboard Motor

Lubrication Point Reference Diagram

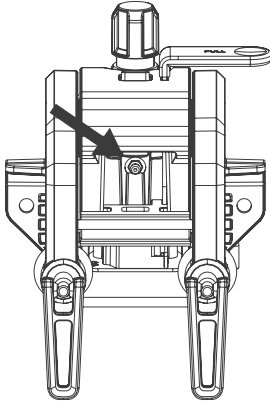

Figure 7-4

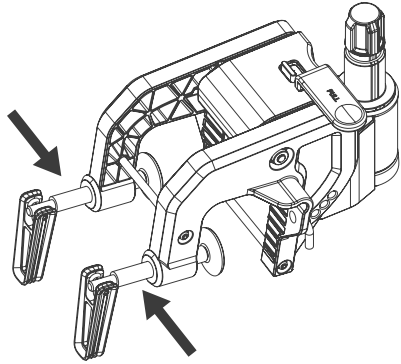

Figure 7-5

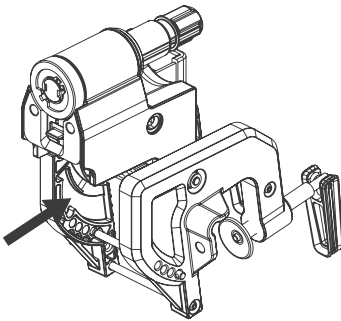

Figure 7-6

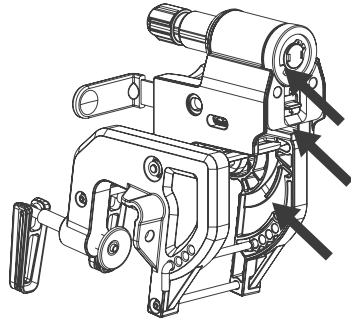

Figure 7-7



Grease Requirements and Precautions: Waterproof grease must be used.

7.6 Regular Maintenance

Regular cleaning and maintenance ensure your outboard motor operates at peak performance. Maintenance frequency depends on usage; refer to the table below for guidance.

Item	Operations	Service Interval	Reference Section
		100 Hours (6 Months)	
Propeller / Propeller Nut / Power Pin	Check / Repair	■	7.2
Anode	Check / Replace	■	7.3
Maintenance of Electrical Contacts	Check / Replace	■	7.4
Lubrication Points	Lubricate	■	7.5



The tiller of the product is made of silicone rubber. When in contact with chemical solvents such as WD40, it poses a risk of causing discoloration. In case of contact with such solvents, the silicone rubber tiller should be immediately rinsed with clean water if the chemical sprays on the tiller surface.

8 Warranty

8.1 Introduction

Congratulations on the purchase of your new ePropulsion Product! We are happy to welcome you to the ePropulsion family! ePropulsion has been deeply involved in the field of marine new energy power for more than ten years, focusing on the research and development, manufacturing and sales of marine electric/hybrid propulsion systems and core components, and has full-chain system integration service capabilities and rich engineering design experience. The main business covers propulsion equipment with a power of 500 watts to 1000 kilowatts, supporting controllers, batteries, main motor remote control systems, energy management systems and smart ship solutions. It is committed to promote the upgrade of marine power systems to new energy and is an industry-leading leader worldwide in marine electric propulsion technology. ePropulsion wants you to enjoy your new ePropulsion product for many years to come and asks you to read and understand the manual before you operate the propulsion to ensure that you follow safe operating practices and maintenance procedures.

This manual should be considered a permanent part of the ePropulsion product and shall remain with it. For correct maintenance, repair and genuine parts, visit an ePropulsion authorized distributor/dealer. Your ePropulsion authorized distributor/dealer is always up to date regarding the latest news and technology and is able to answer all your questions concerning your ePropulsion product. You can locate your nearest ePropulsion authorized distributor/dealer by visiting the website of ePropulsion <https://www.epropulsion.com/contact/find-a-dealer>.

Before installing or using your ePropulsion product, please read and understand this manual and the applicable Operation Manual carefully. If you did not receive an Operation Manual, please download a copy from <https://www.epropulsion.com/service/download-center>.

8.2 Limited Warranty

8.2.1 Overview

Guangdong ePropulsion Technology Limited, Room 801, Building 1; 11 Daxue Road, Songshan Lake; CN Dongguan Guangdong Province ("ePropulsion"), provides this Limited Warranty manual to help you take full advantage of your electric propulsion product and its intelligent integrated system product for boats produced by ePropulsion ("ePropulsion Product").

ePropulsion warrants that at the time of shipping, new ePropulsion Products sold by ePropulsion and/or its authorized distributors/dealers will be free from defects in material and workmanship during the limited warranty period specified in Section 8.2.4. A defect exists if the actual condition of the ePropulsion Product differs from the agreed condition or the published specifications.

This Limited Warranty is applicable in all countries and can be enforced in any country or region where ePropulsion or its authorized distributors/dealers provide ePropulsion Products subject

to the terms and conditions set forth in this Limited Warranty. This Limited Warranty is subject to all applicable national export and import laws and regulations.

This Limited Warranty is subject to limitations referred to in Section 8.2.3 and 8.2.8.

ePropulsion warrants to the first purchaser who buys the ePropulsion Product to use it ("First Purchaser") that it will make the repairs or replacements necessary to correct defects for the limited warranty period specified in Section 8.2.8. If the ePropulsion Product is transferred to another purchaser during the limited warranty period, it is suggested that the second purchaser notify ePropulsion in text form (e.g. email to service@epropulsion.com) at the time the second purchaser takes possession of the ePropulsion Product.

Unless expressly stated otherwise in this Limited Warranty, all provisions herein apply exclusively to consumers using ePropulsion Products for recreational use unless otherwise stipulated in Section 8.2.4 (1) and 8.2.5. ePropulsion Products used for commercial or professional purposes (with the exception of light commercial use as defined in Section 8.2.4(2)) are not covered by this Limited Warranty; instead, the statutory warranty in your jurisdiction applies. We recommend consulting an ePropulsion authorized distributor/dealer to clarify the applicable warranty coverage before using the ePropulsion Product for such purposes.

This Limited Warranty does not affect any mandatory statutory rights you may have under the laws of the country in which you have your habitual residence, including any rights or claims you may have under your purchase contract with the ePropulsion authorized distributor/dealer from whom you purchased the ePropulsion Product. The assertion of these statutory rights in the event of defects is free of charge and is not restricted by this Limited Warranty.

8.2.2 Product Registration

ePropulsion Products are Single Products, eSSA System Products and their accessories, as listed in the table below. This limited warranty period applies to all ePropulsion Products and their accessories.

Product Type	Specific Product Series
Single Products	eLite series, Spirit series, Navy series, Pod drive series, E batteries series, accessories
eSSA System Products	X series, P eSSA series, I series, G batteries series

In order to obtain your ePropulsion Product Limited Warranty and to receive quick support for service, parts and technical documentation, ePropulsion strongly recommends that you submit an online product registration via <https://www.epropulsion.com/service/product-registration> within (30) days after you have purchased the ePropulsion Product. The following information is required to register the ePropulsion Product:

- Product Model:

- Product Serial Number (SN):
- Purchase Date:
- Owner Information (Name, Address, Email/Phone):
- Boat Information (Model, Boat Type, Application, Propulsion Type):
- Dealer Information (Dealer Name, Contact Person, Email/Phone)

The benefits of registering your ePropulsion Product include:

- It confirms that you are the legal owner.
- warranty claims can be processed more quickly.
- if necessary, the ePropulsion Service Network can communicate directly with you.
- you have the option to sign up for ePropulsion latest news, keeping you up to date on new ePropulsion Products and features.
- other benefits that are published on the ePropulsion website, including but not limited to warranty extensions (please refer to the ePropulsion website for specific information).

Personal data shall be collected, processed and used by ePropulsion exclusively for the purpose of performing and managing this Warranty Policy, including but not limited to verifying your eligibility for warranty coverage, processing warranty claims (e.g., repair, replacement or maintenance requests for the warranted product), communicating warranty-related information (such as notifications of warranty status, product safety updates or progress of warranty service), and fulfilling other obligations under this Limited Warranty. For detailed information on ePropulsion’s personal data protection please refer to ePropulsion’s Privacy Policy at <https://www.epropulsion.com/privacy-policy/>.

8.2.3 Important Limitations

This Limited Warranty applies only to ePropulsion Products manufactured by ePropulsion and sold by ePropulsion or its authorized distributors/dealers. It only applies if the ePropulsion Product is installed and commissioned in accordance with the respective ePropulsion Product installation and operation guidelines contained in the user manual and used and maintained in accordance with the respective ePropulsion user manual. **For eSSA System Products, installation and commissioning must be performed by an ePropulsion authorized distributor/ dealer.**

If a defect arises within the limited warranty period, ePropulsion may, at its discretion, choose to repair or replace the ePropulsion Product or part. ePropulsion will undertake the repair or replacement without charge for parts or repair labour. Repair labour includes the cost of labour to remove and reinstall the ePropulsion Product and, if necessary to complete the warranty service, to replace the non-ePropulsion Product components of the vessel in which the ePropulsion Product is installed.

Please note that ePropulsion Products are sophisticated and complex machinery that may be affected by many variables associated with their application. As such repairs may require multiple attempts and may take significant time (up to three (3) months) from the date on which ePropulsion or its authorized distributor/dealer confirms receipt of the defective ePropulsion

Product. The repairing time shall delete the duration of waiting time includes waiting time because of customer's delay, statutory/public holidays and force majeure.

After the limited warranty period has expired, you can still enjoy maintenance services from ePropulsion authorized distributors/dealers. In this case, service and accessories fees apply. These fees are based on the rates quoted by the ePropulsion authorized distributor/dealer.

8.2.4 Warranty Periods

The limited warranty period begins on the date of receipt of the ePropulsion Product by the First Purchaser. For the **eSSA System Products**, the limited warranty period **begins on the date of commissioning** the ePropulsion Product approved by ePropulsion.

The warranty periods for ePropulsion Products vary significantly based on the nature of their use, namely commercial use and non-commercial use (which encompasses recreational use and light commercial use).

(1) Warranty Periods for Recreational Use

"Recreational use" means the use of the ePropulsion Product for personal leisure, entertainment, or hobby-related activities, without any intent to generate income or profit. This use is limited to the user, their family, or a small group of non-paying friends. For example:

1. using an ePropulsion-equipped boat for a weekend fishing trip with family members, provided that no one is engaged in fishing for commercial sale;
 2. participating as a hobbyist in a local, non-competitive boating event, using an ePropulsion Product to power the boat.
- **Single Products:** Twenty-four (24) months or 1000 hours (whichever comes first) from the date of receipt of the ePropulsion Product by the First Purchaser, or the limited warranty period you obtained when you registered your ePropulsion Product, whichever is longer.
 - **eSSA Products:** Twenty-four (24) months or 1000 hours (whichever comes first) from the date of sea-trial delivery and commissioning. The limited warranty period shall not exceed twenty-six (26) months or 1015 hours (whichever comes first) from the date the First Purchaser receives the ePropulsion eSSA System Product.

(2) Warranty Periods for Light Commercial Use

"Light commercial use" means the use of the ePropulsion Product in activities that are non-profit driven, public welfare oriented, or to support of community-focused initiatives. Such use is usually carried out by non-commercial organizations and may serve public interest, educational or research purposes.

- **Single Products:** Twenty-four (24) months or 1000 hours (whichever comes first) from the date of receipt of the ePropulsion Product by the First Purchaser, or the limited warranty period you obtained when you registered your ePropulsion Product, whichever is longer.
- **eSSA Products:** Twenty-four (24) months or 1000 hours (whichever comes first) from the

date of sea-trial delivery and commissioning. The limited warranty period shall not exceed twenty-six (26) months or 1015 hours (whichever comes first) from the date the First Purchaser receives the ePropulsion eSSA System Product.

(3) Warranty Periods for Commercial Use

"Commercial use" means any utilization of the ePropulsion Product in activities primarily intended for generating income or profit or otherwise carried out in support of a business operation. For example:

1. using ePropulsion Product in a commercial fishing enterprise where the catch is sold for profit;
2. incorporating ePropulsion Products into a tour-guiding business that offers paid boating tours.
 - **Single Products:** Twelve (12) months or 1000 hours (whichever comes first) from the date of receipt of the ePropulsion Product by the First Purchaser, or the limited warranty period you obtained when you registered your ePropulsion Product, whichever is longer.
 - **eSSA Products:** Twelve (12) months or 1000 hours (whichever comes first) from the date of sea-trial delivery and commissioning. The limited warranty period shall not exceed fourteen (14) months or 1015 hours (whichever comes first) from the date that the First Purchaser receives the ePropulsion eSSA System Product.

Any ePropulsion Product or part repaired or replaced under the Limited Warranty assumes

the remaining limited warranty period or ninety (90) days, whichever is longer. If only parts are replaced under warranty, the 90 days warranty covers the replaced parts only, the ePropulsion Product itself will remain the original warranty period). Any original part of an ePropulsion Product (except for consumable parts) purchased separately by the customer is covered by a limited warranty period of ninety (90) days.

If the ePropulsion Product is transferred to another purchaser during the limited warranty period, the remaining limited warranty period is transferred to that purchaser. The transfer of this Limited Warranty will not extend its duration. Warranty coverage that has not yet expired cannot be transferred to or from a customer using the product for commercial purposes.

8.2.5 Non-commercial Use

The Limited Warranty applies only to ePropulsion Products purchased by consumers and used solely for recreational purposes and not for any commercial application.

Insofar as the ePropulsion Product is used by consumers for light commercial use, the limited warranty shall apply mutatis mutandis, whereby the limited warranty periods in Section 8.4 (2) in this manual shall apply for possible warranty coverage.

8.2.6 Commercial Use

In case of commercial use as defined in Section 8.4 (3), any commercial contract (including but

not limited to the Product Sales Contract or the Purchase Agreement) entered into between the commercial customer and ePropulsion or its authorized distributor/dealer, the warranty terms in the commercial contract shall prevail over this Limited Warranty, if the commercial contract stipulates warranty terms. For all warranty matters beyond the scope of the commercial contract, the provisions of this Limited Warranty shall apply.

8.2.7 Warranty Procedures

If you believe your ePropulsion Product is defective, you must contact an ePropulsion authorized distributor/dealer within fifteen (15) days after discovering the defect. Your authorized distributor/dealer will provide you with the contact details (name, address and telephone number) of the designated service facility.

You are responsible for transporting your ePropulsion Product to and from the designated service facility. Any delivery or transportation costs incurred in the process shall be borne by you, except where such costs arise in connection with the assertion of your statutory rights under the applicable sales contract. In certain cases, your ePropulsion authorized distributor/dealer may, at ePropulsion's sole discretion and subject to prior agreement, arrange for the inspection and/or repair to be performed on-site.

The following procedures must be followed to make a warranty claim:

1. Contact your nearest ePropulsion or ePropulsion authorized distributor/dealer. They will inform you whether the defect is covered by this Limited Warranty or their own warranty and provide the contact details (name, address and telephone number) of the designated service facility.
2. Provide proof of first purchase (e.g., receipt or invoice showing ePropulsion Product, date and the serial number) or commissioning (e.g. the form that shows the commissioning date). Product labels must be kept intact. Claims are valid only if the information provided is correct, genuine, and complete. If you have registered the ePropulsion Product on the official website, proof of first purchase or commissioning is not necessary.
3. Use the original box and packaging material of the ePropulsion Product for transport or equivalent packaging and packaging material for sending the ePropulsion Product to the designated service facility. Pack the ePropulsion Product in such a way that any damage caused by improper packaging during transport is avoided (e.g. by using sufficient padding). ePropulsion is not liable for any damage caused by improper packaging during transport. In certain cases, instead of shipping the products back, on-site service will be managed.
4. Keep defective items available for inspection by ePropulsion or an ePropulsion authorized distributor/dealer for the duration of the inspection. You can request the return of the ePropulsion Product. ePropulsion will arrange the return. If ePropulsion replaces the ePropulsion Product or part of the ePropulsion Product, the replacement becomes your property and the ePropulsion Product or the part of the ePropulsion Product that is replaced, becomes the property of ePropulsion.
5. ePropulsion or the ePropulsion authorized distributor/dealer will conduct diagnosis and

examination on the defective ePropulsion Product to verify the validity of the warranty claim:

- If your warranty claim is accepted, the ePropulsion Product or its defective parts will be repaired or replaced free of charge.
- If your warranty claim is rejected, you will receive an estimate for repair/replacement of the ePropulsion Product, including the costs of round-trip delivery. ePropulsion or the ePropulsion authorized distributor/dealer will only begin the work after receiving your written confirmation.

Any action arising hereunder must be commenced within one (1) year after the cause of action accrues, unless you are a consumer, in which case a statutory limitation period of two (2) years applies. Any actions commenced after this period shall be barred.

8.2.8 Excluded from the Limited Warranty

In addition to the other conditions and limitations set forth in Section 8.2.3, the following items are specifically excluded from any coverage under this Limited Warranty:

1. Ordinary wear and tear (e.g. aging of sealing rings, fading of external appearance, reduction in display screen brightness, battery capacity attenuation, decrease in cruising range; loose interfaces that still enable normal connection).
2. consumable parts (e.g. propeller, anode).

This Limited Warranty does not cover any defect, damage, cost, or consequence resulting from:

1. Use not in accordance with the Operation Manual or intended use described therein. This includes:
 - Willful abuse, misuse, negligence or accidents,
 - physical damage (including overcharging or over discharging),
 - installation, handling, operation, or maintenance inconsistent with the instructions in the Operation Manual,
 - failure to perform the required maintenance,
 - delay of more than two (2) months in claiming the repair of the ePropulsion Product despite being aware of the defect,
 - racing or engaging in a contest of speed or endurance,
 - use of non-approved attachments, non-genuine parts, or spare parts of non-equivalent quality,
 - incorrect software settings or unauthorized modifications to software,
 - incorrect storage, e.g. long storage resulting in battery failure, dried/cracked rubber components, or corrosion of electrical contacts/connectors,
 - not performing and paying for regular maintenance and failing to maintain records of all service and maintenance,
 - running aground, incorrect propeller matching, or similar operation against the Operation Manual,
2. unauthorized modification, repair or tampering of

- the ePropulsion Product, accessory, or part (including removal or alteration of the ePropulsion Product label or the serial number),
 - the power, control, or electrical system,
 - service performed by a non-authorized facility,
3. environmental exposure, e.g.
 - rust or corrosion in electrical contacts or connectors,
 - submersion or exposure to unsuitable environmental conditions, such as high humidity, heavy rainfall, seawater intrusion, or freezing of the cooling water,
 4. parts and repair costs of failure due to misdiagnosis,
 5. damage due to improper packing during transport,
 6. repairs outside normal working hours,
 7. service-related costs such as installation, disassembly, financing, rental, or similar costs,
 8. non-compliance with applicable laws and regulations governing the transport or packaging of lithium batteries (classified as a UN9 hazardous items), and
 9. for commercial customers (B2B) only, transporting the ePropulsion Product, part, or vessel in which the ePropulsion Product is installed, to and from the designated service facility (including any haul-out fees or storage fees).

In all warranty claims, ePropulsion will only bear the costs of diagnosing, repairing, or replacing a defective part. In no event shall ePropulsion or ePropulsion Authorized Distributor/dealer be liable for incidental, special or consequential damages. Such damages include, but are not limited to, loss of profits, haul-out fees, launching costs, towing, storage, slip fees, insurance coverage, loan payment, transportation costs, telephone charges, and mileage.

8.3 Miscellaneous

- Except as modified in writing and signed by the parties, and except where a commercial contract expressly provides otherwise, this Limited Warranty is and shall remain the complete and exclusive agreement between the parties with respect to warranties, superseding all prior written or oral agreements, and all other communications between the parties relating to warranties.
- No original equipment manufacturers, boat builders, ePropulsion product installers, distributors, dealers or any other person or entity has any authority to make any representation or promise on behalf of ePropulsion or to modify the terms or limitations of this Limited Warranty in any way, whether orally or in writing.
- This Limited Warranty is subject to German law, excluding the United Nations Convention on Contracts for the International Sale of Goods (CISG). The courts in Germany shall have exclusive jurisdiction. If you are a consumer and have your habitual residence in the EU, you may also bring your claim in the country in which you live and you additionally enjoy the protection afforded to you by the mandatory provisions of the law of your country of residence.

ePropulsion

(*In order to validate warranty, please fill in this form first and read the Warranty Policies.)

|| OWNER INFO. ||

Owner Name			
Address			
Phone		Email	

|| DEALER INFO. ||

Store Name			
Address			
Phone		Email	

|| PRODUCT INFO. ||

Date of Purchase (mm/dd/yyyy)	
Serial No.	



Thanks for reading this user manual.

If you have any concerns or find any problems while reading, please don't hesitate to contact us. We are delighted to offer service for you.

Guangdong ePropulsion Technology Limited

Website: www.epropulsion.com

E-Mail: service@epropulsion.com