

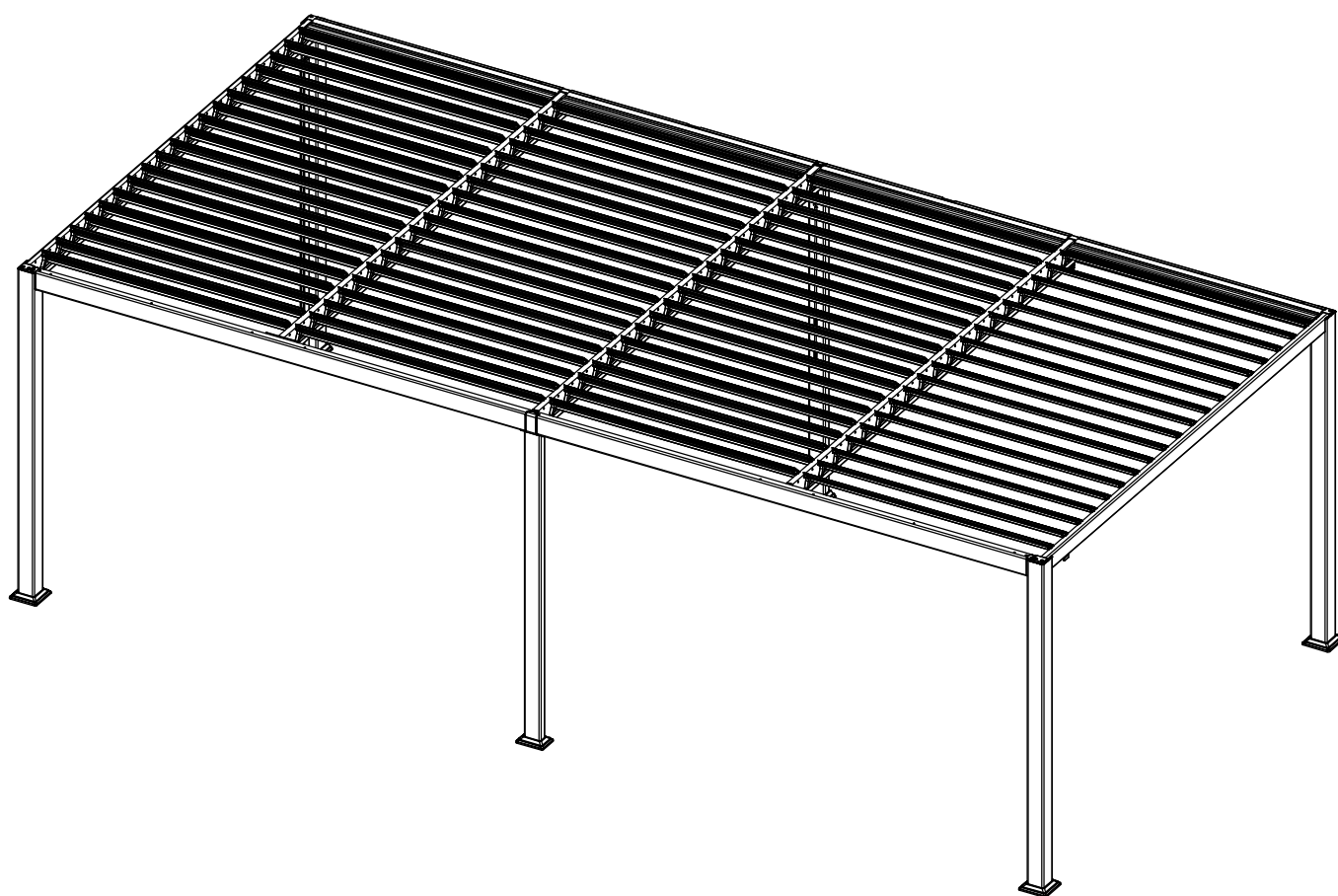































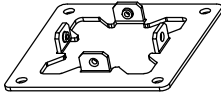

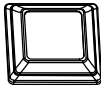
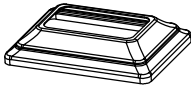
ASSEMBLY INSTRUCTION

7.2*3.5*2.3M

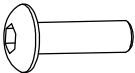
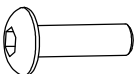
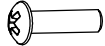
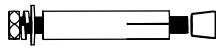
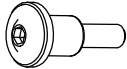

REF	PCE	PIECE		QTY	DIM
	A1			2	
	A2			2	
	A3			2	
	B1			2	
	B2			2	
	C1			1	
	C2			1	
	D			1	
	D1			1	
	D2			1	
	F			152	
	G			4	
	H			4	
	H1			2	

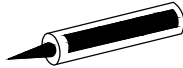
REF	PCE	PIECE	QTY	DIM
	J		4	
	J1		2	
	L		4	
	M		2	
	R		1	
	S1	 M6*15	38+2	
	S2	 M8*20	52+2	
	S3	 M4*18	4	
	S4		12+1	
	S5		2	
	T1		2	
	T2		1	
	T3		1	
		 Silicone neutral glass glue, purchased by customers		

STEP 01

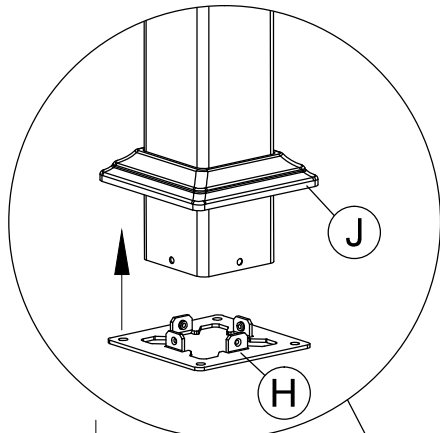



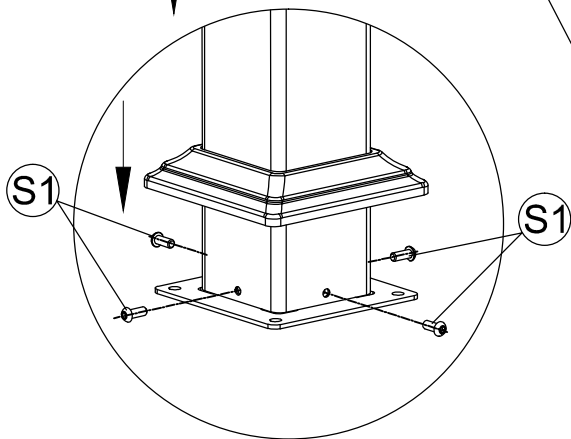

Step1-1

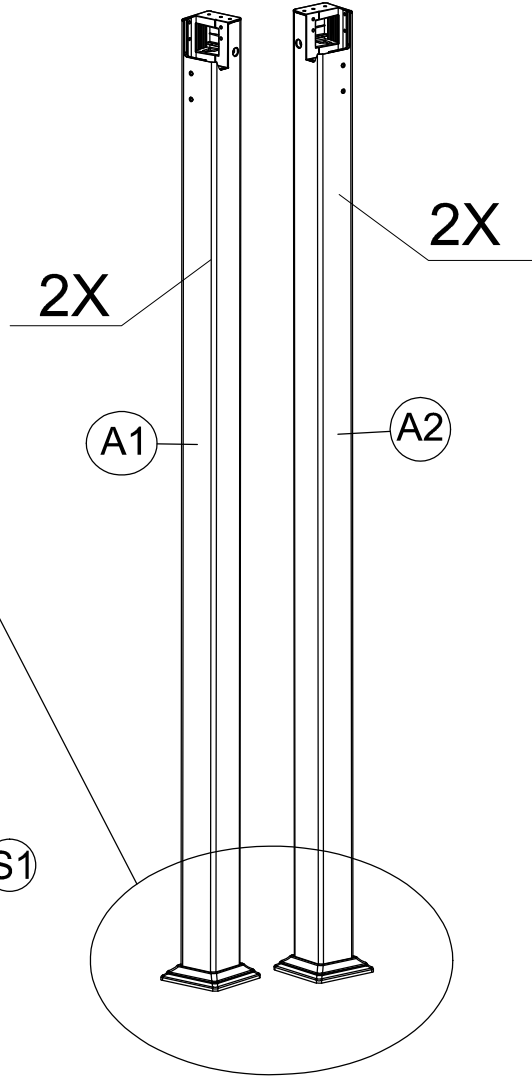

Step1-2

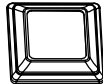

	(2X) A1		(4X) H
	(2X) A2		(4X) J
	 M6*15	(16X) S1	

STEP 02

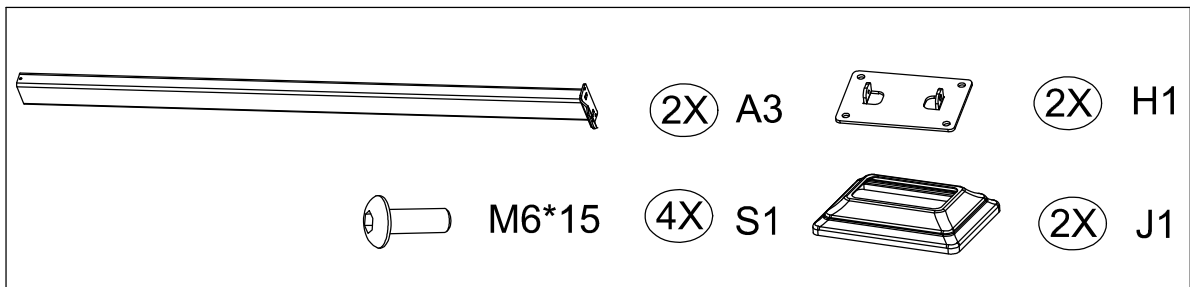
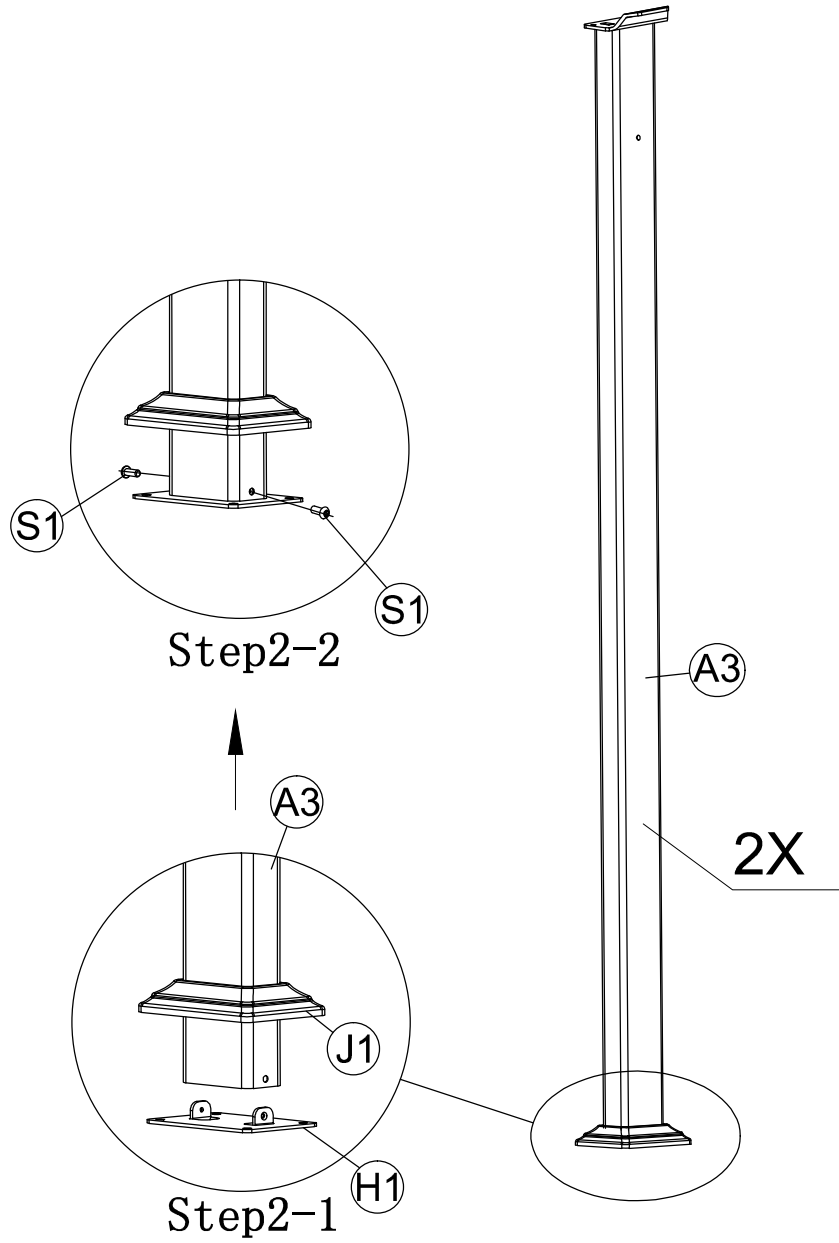

STEP 03

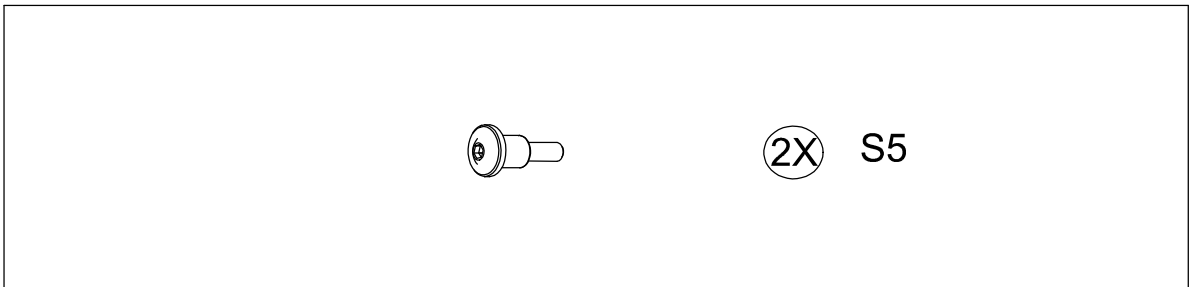
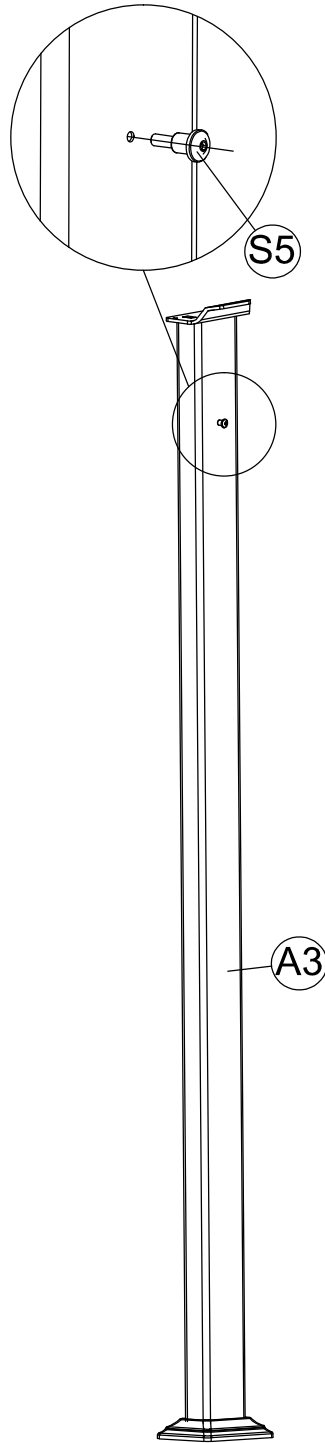

STEP 04

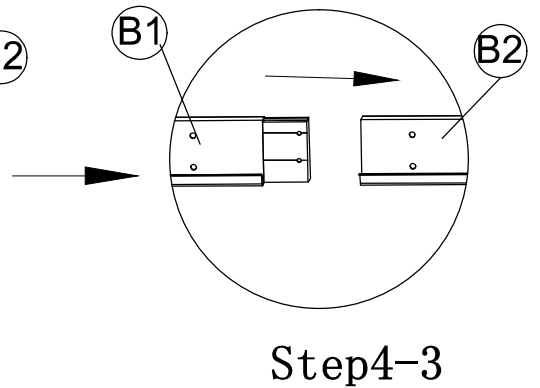
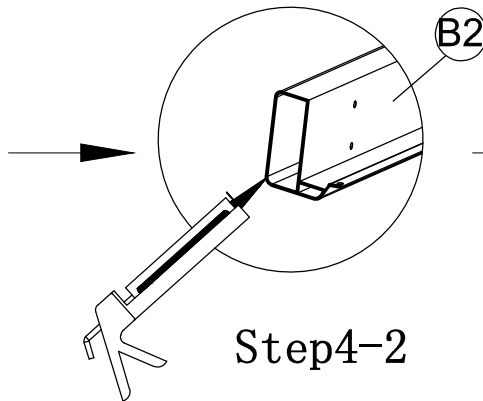
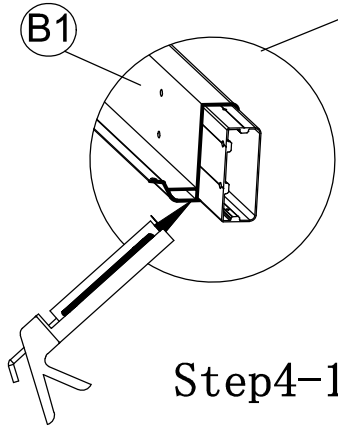
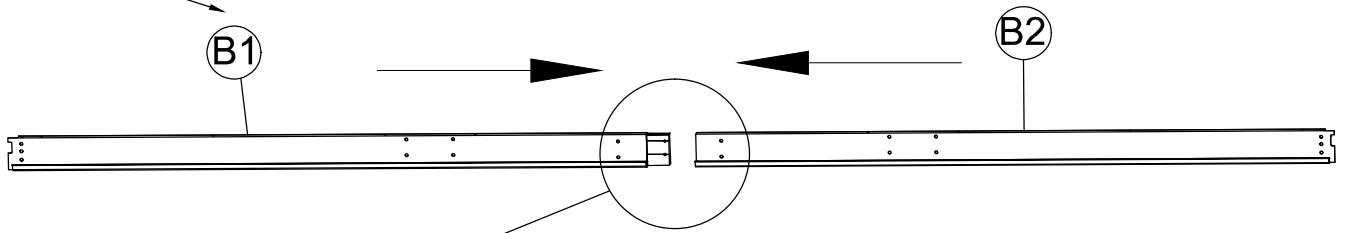

STEP 05

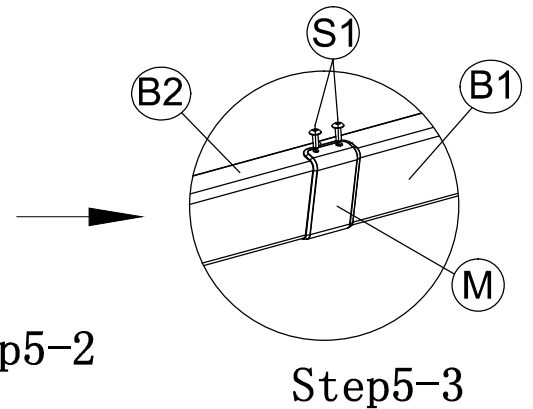
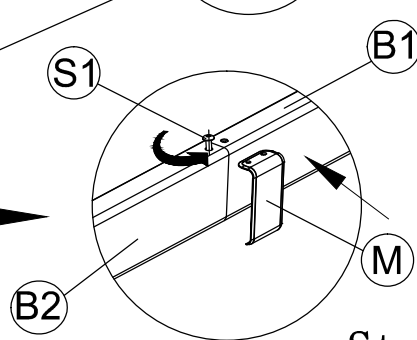
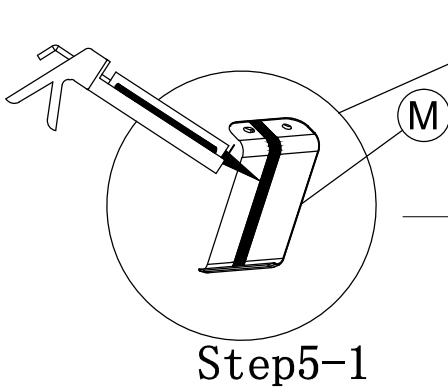
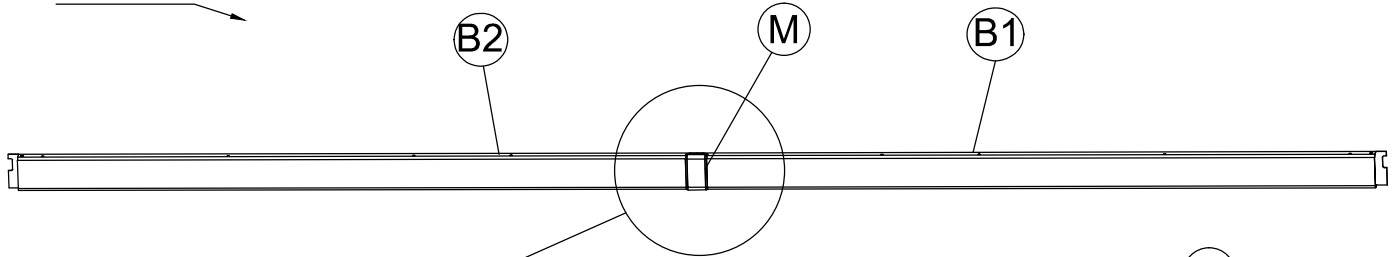

Take out part (S1) first, then assemble part (M)

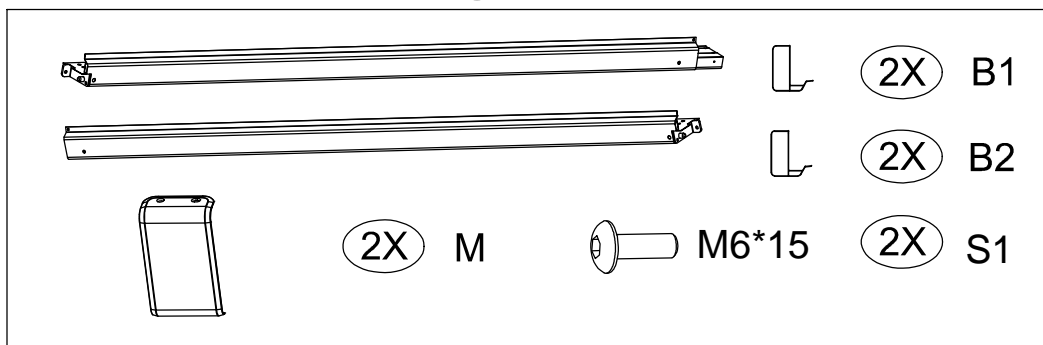

STEP 05

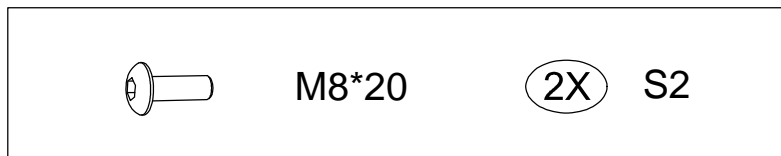
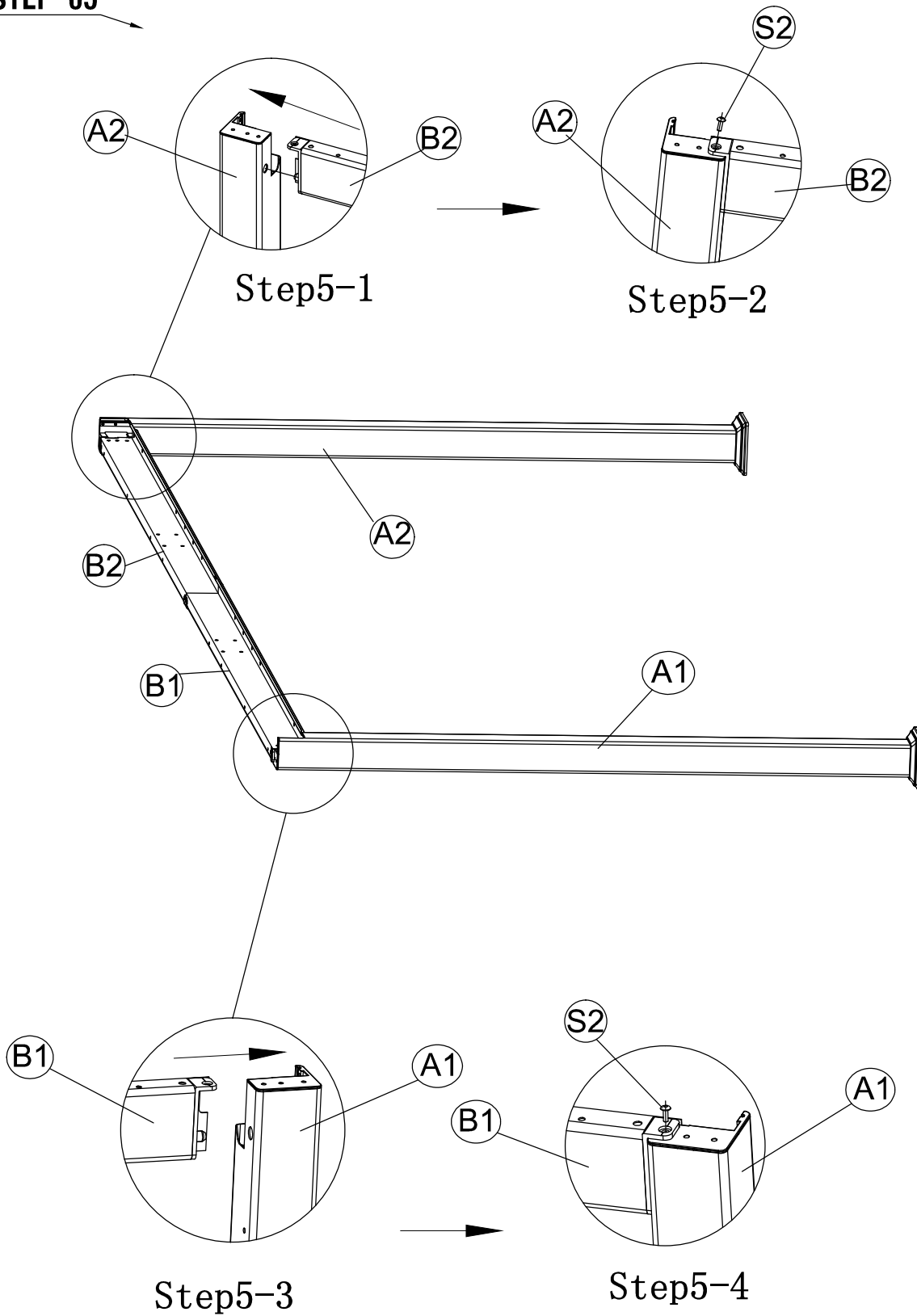

STEP 06

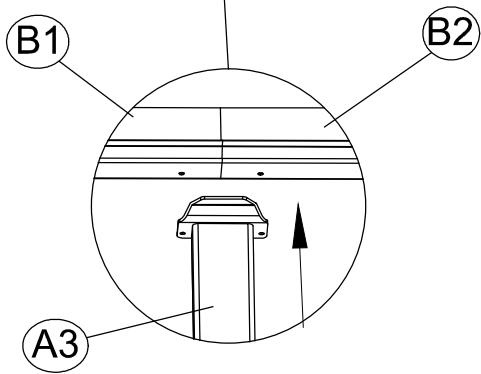
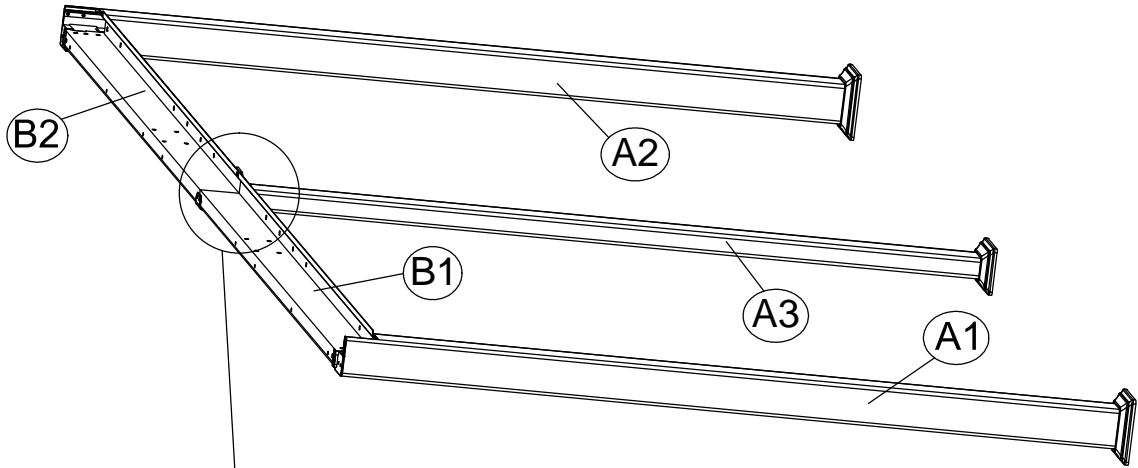

Step6-1

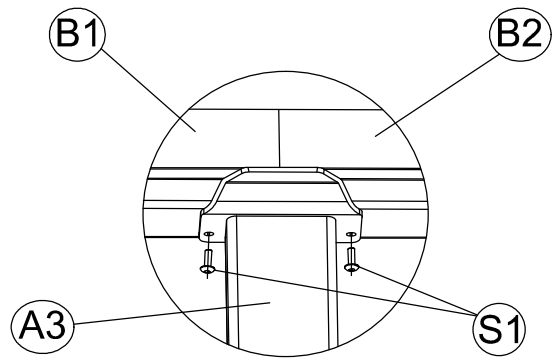

Step6-2

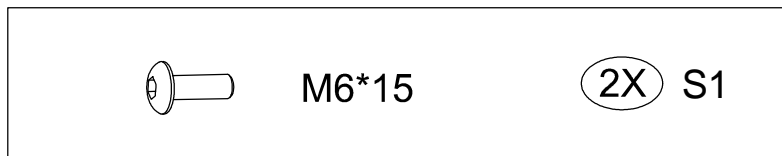

STEP 07

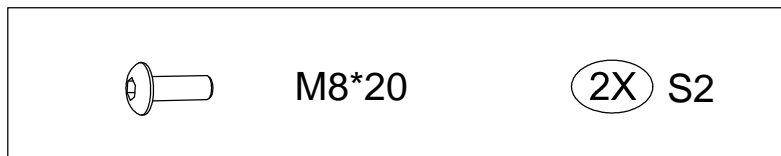
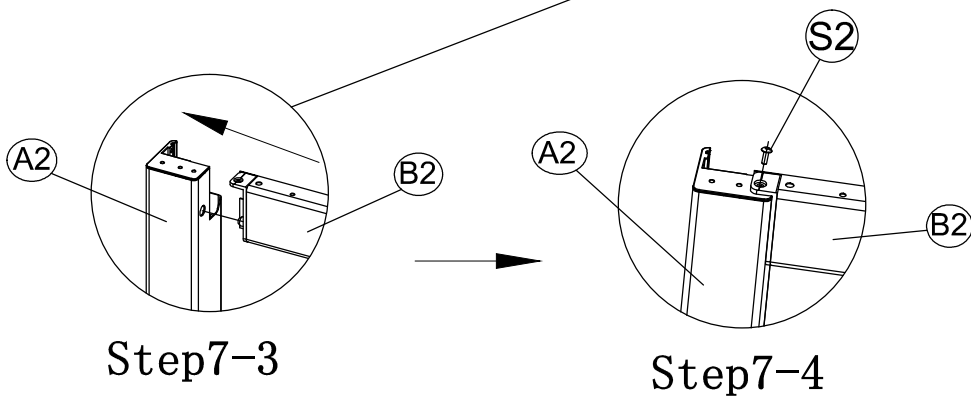
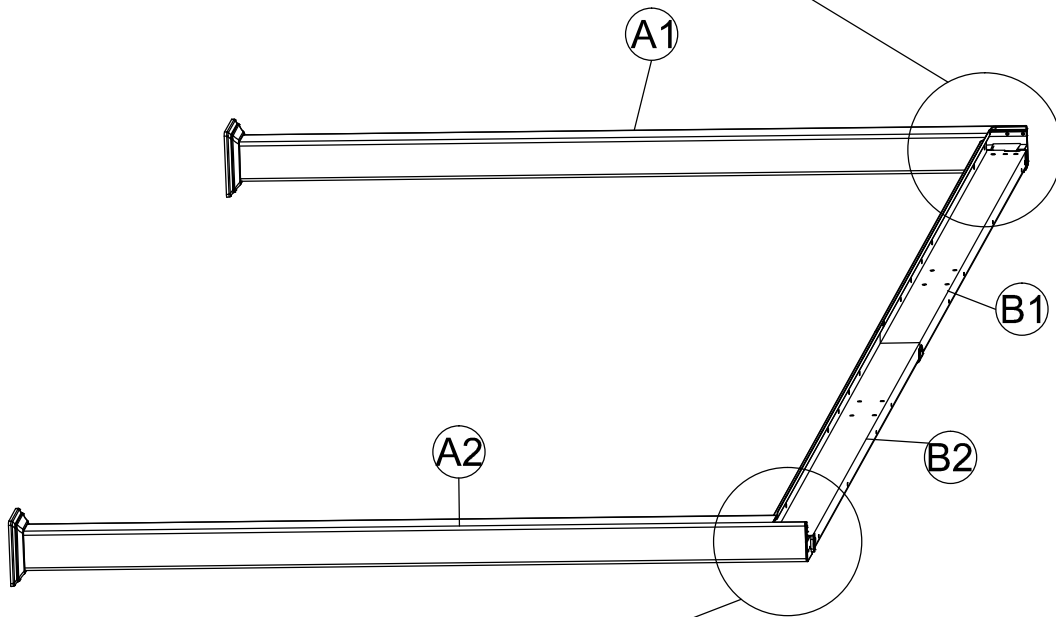
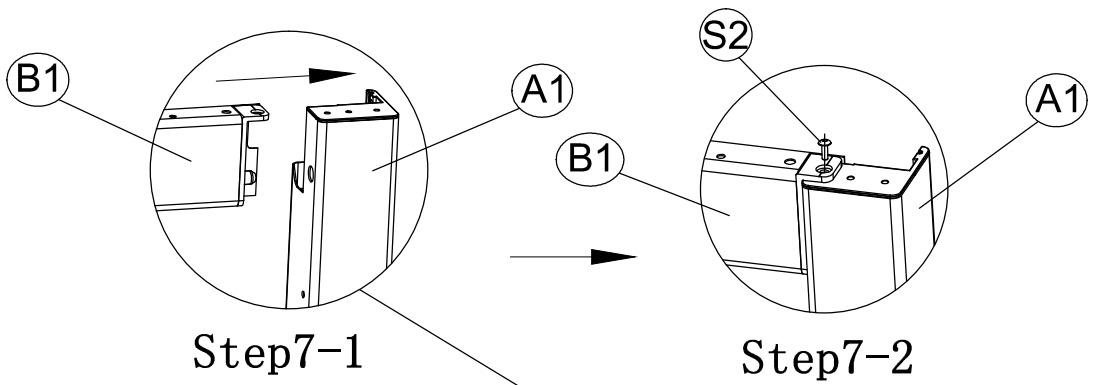

STEP 08

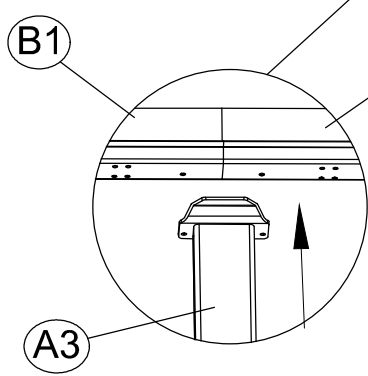
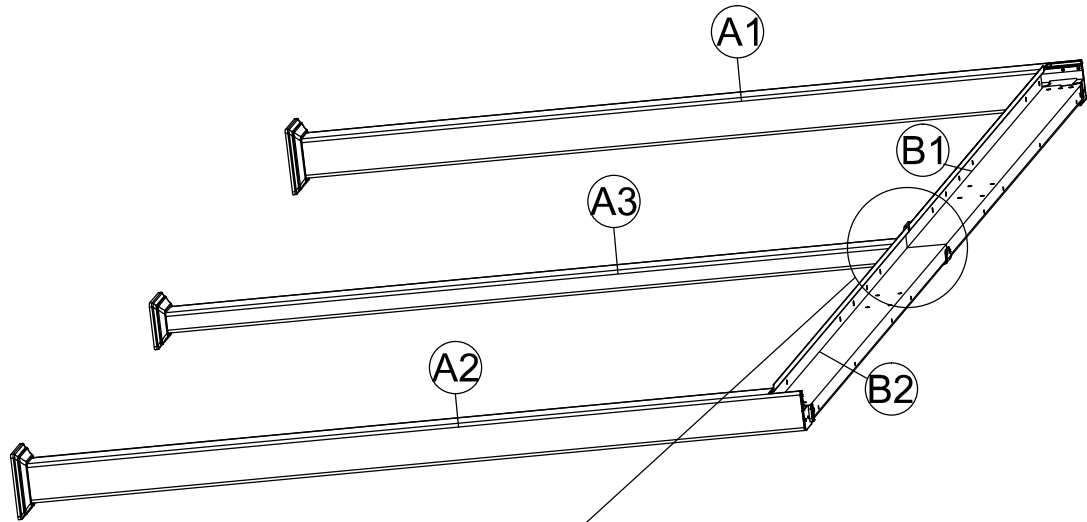

Step8-1

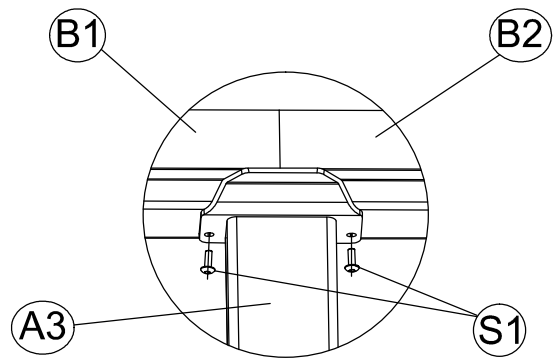
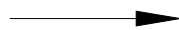

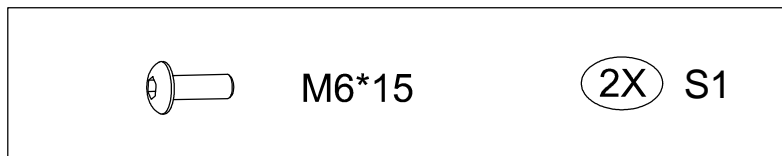

Step8-2



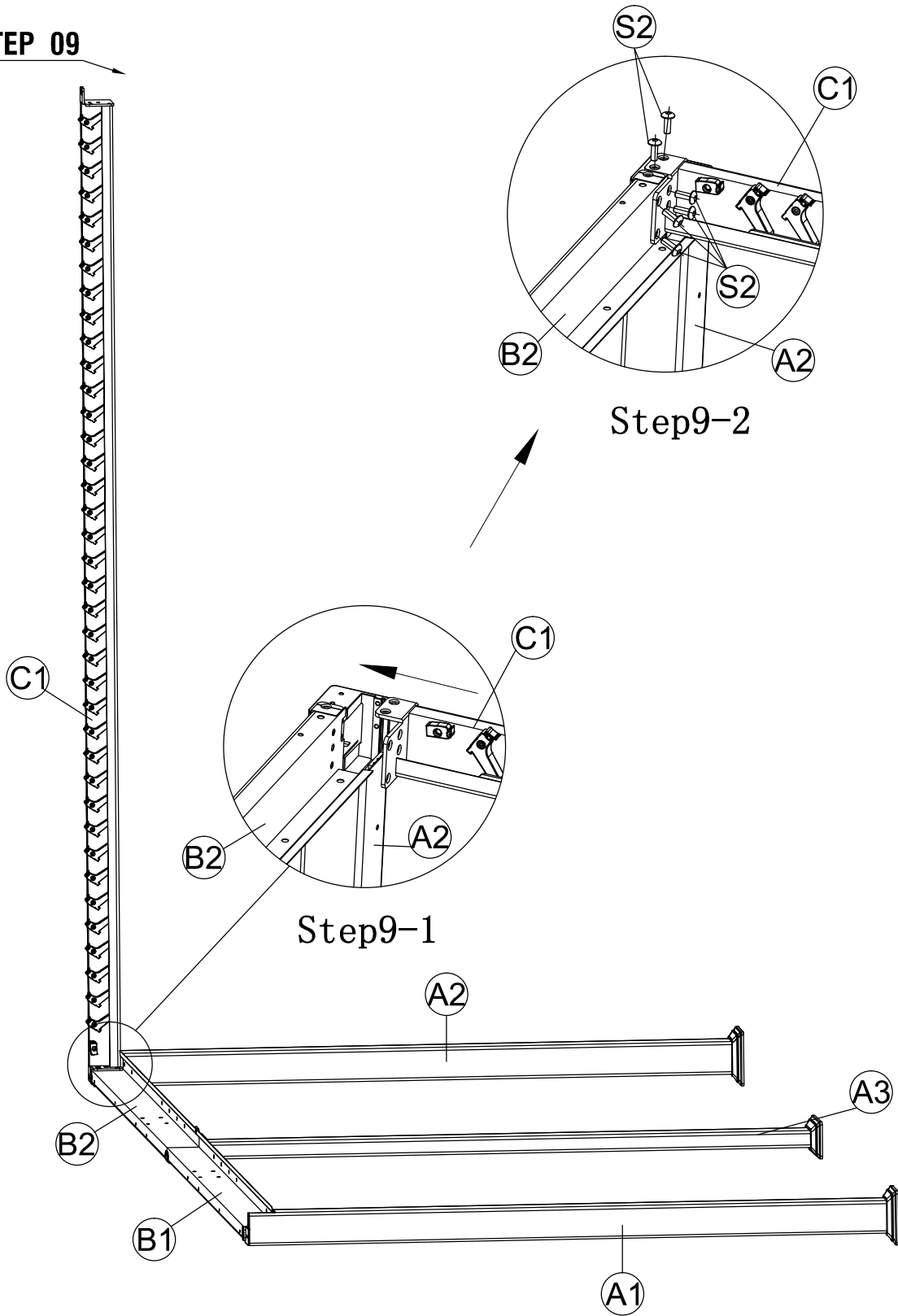



STEP 09

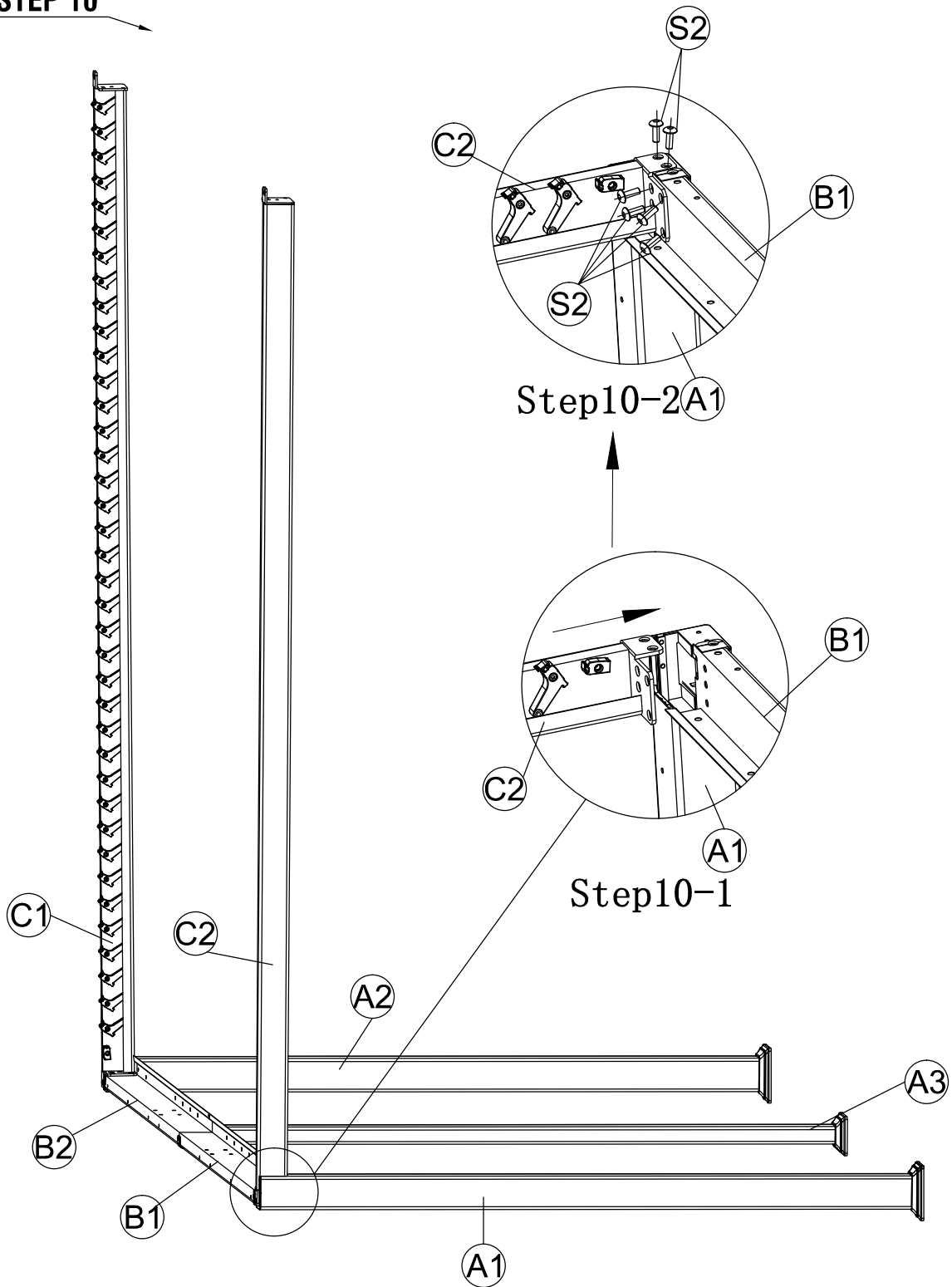

		1X C1
	M8*20	6X S2



STEP 10



		(1X) C2
	M8*20	(6X) S2

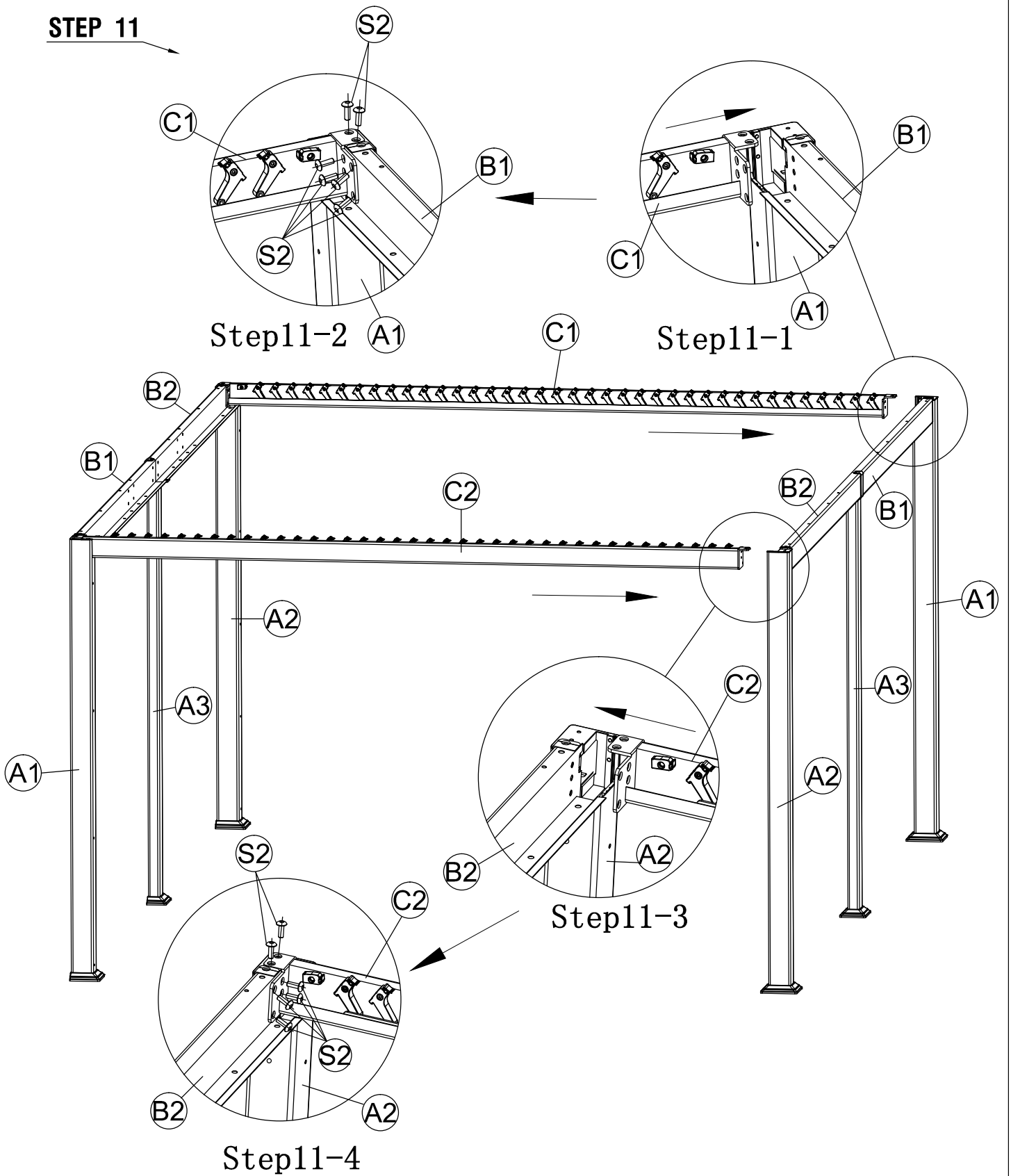





STEP 11

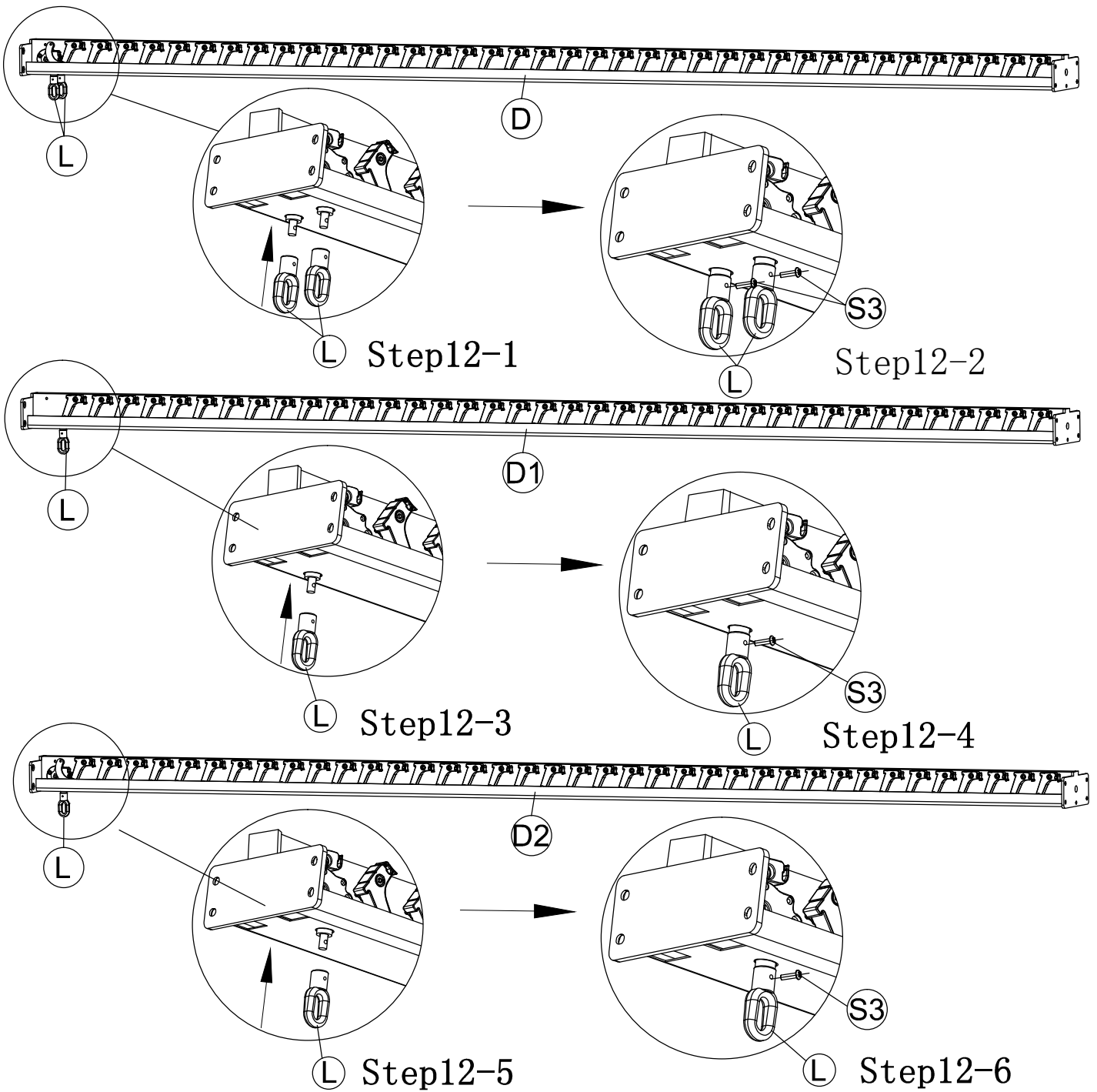

	M8*20		S2
---	-------	---	----

STEP 12



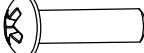

		(1X)	D
		(1X)	D1
		(1X)	D2
	(4X)	L	
	M4*18	(4X)	S3

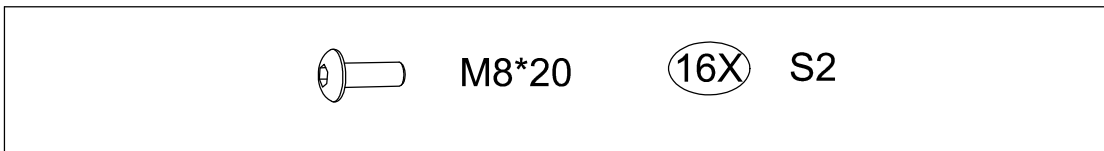
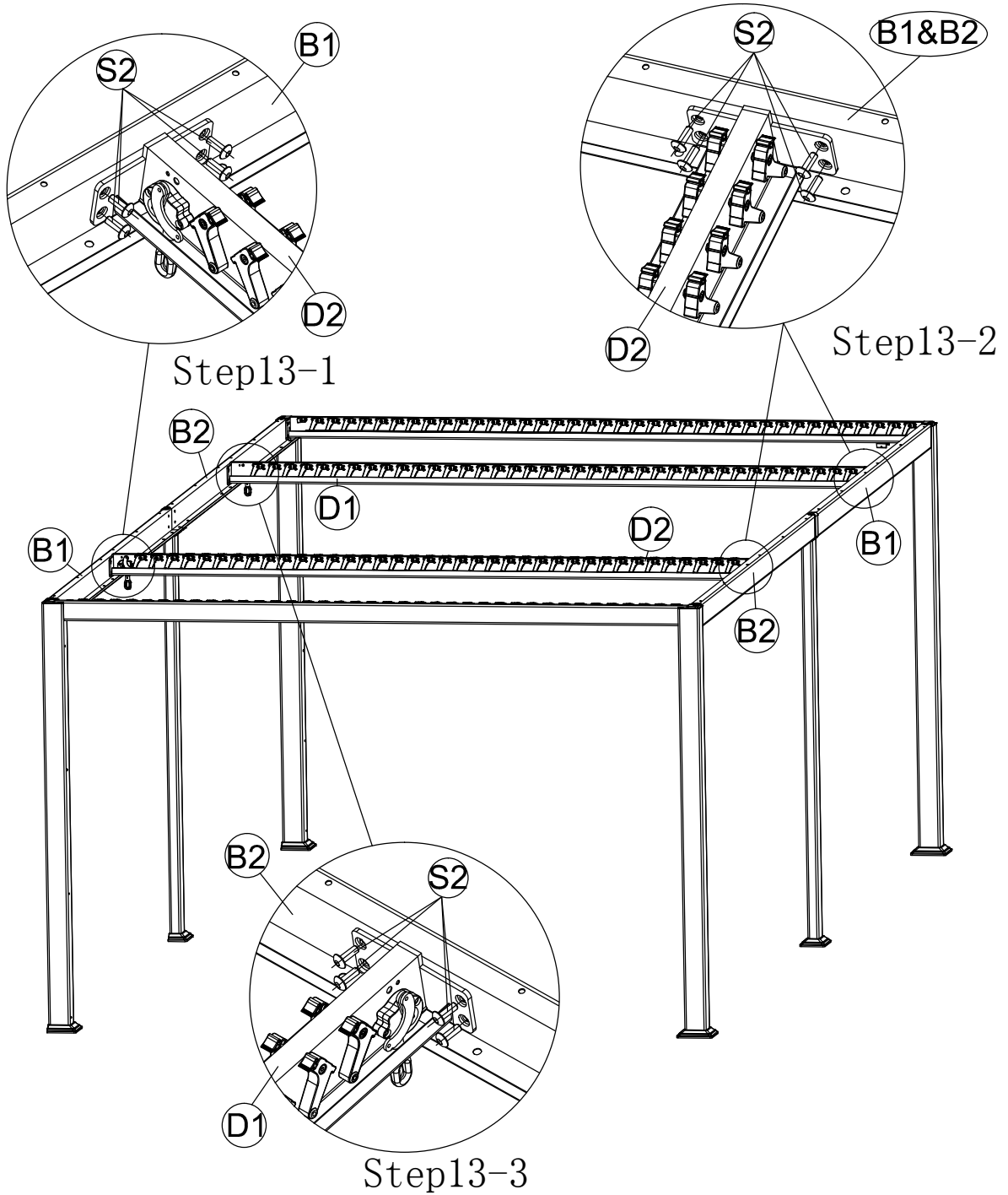
STEP 13

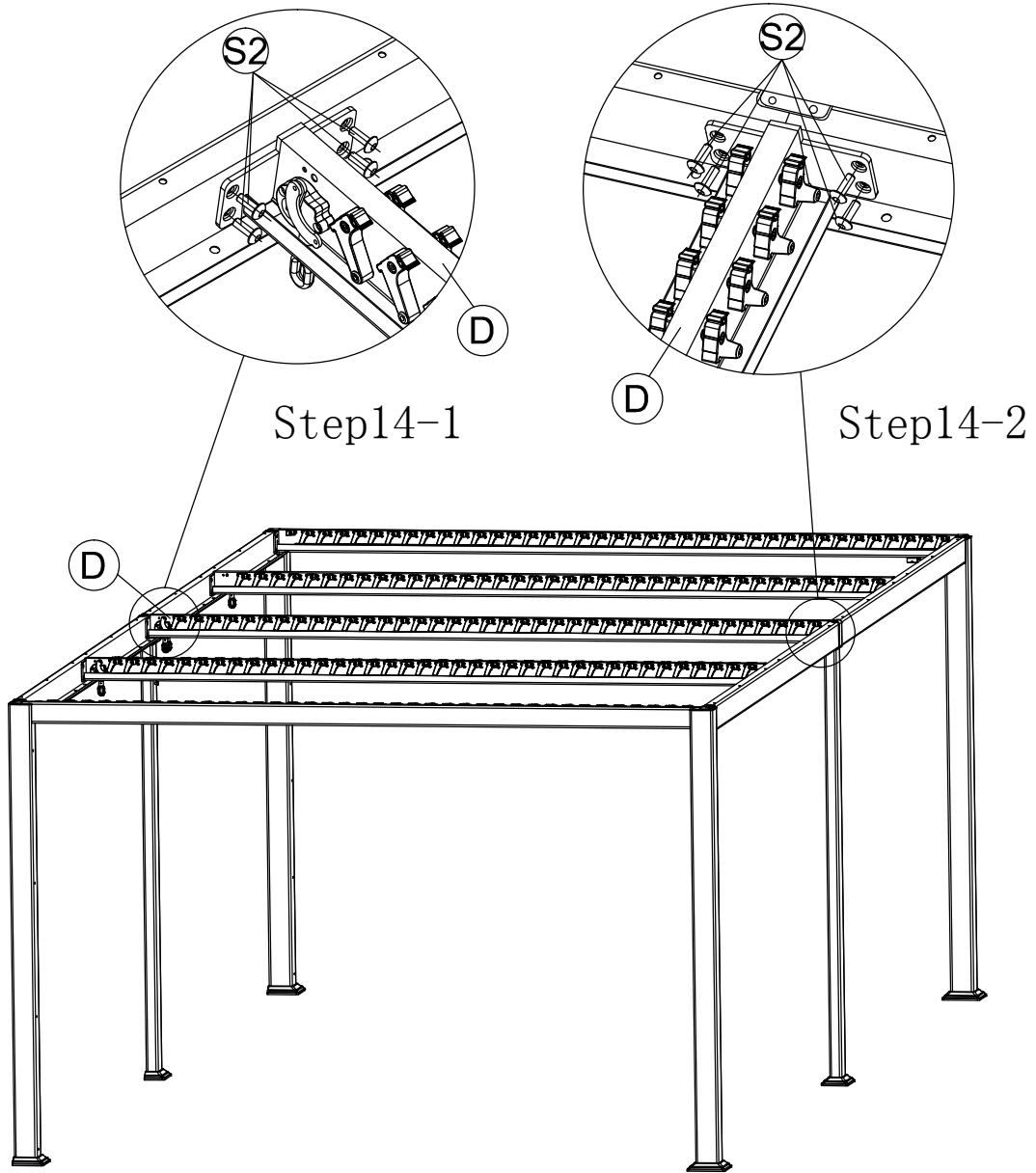

STEP 14



	M8*20		8X S2
---	-------	---	-------

STEP 15

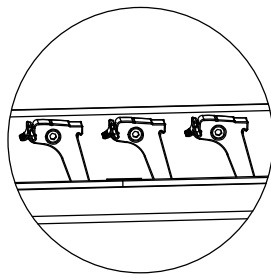
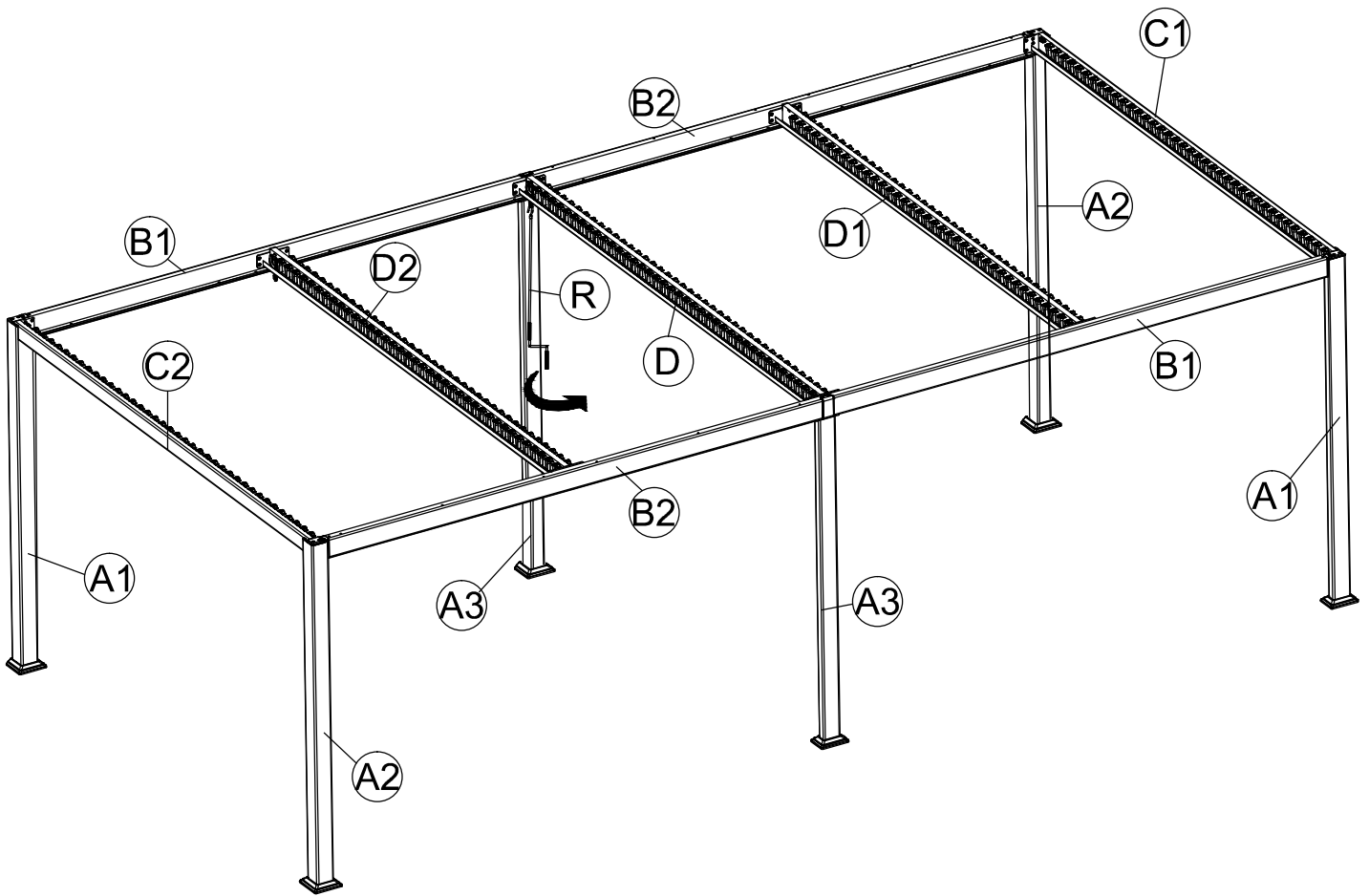

1

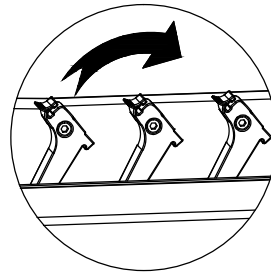

2

Turn the position from picture 1 to picture 2 first, then assemble the shutter.

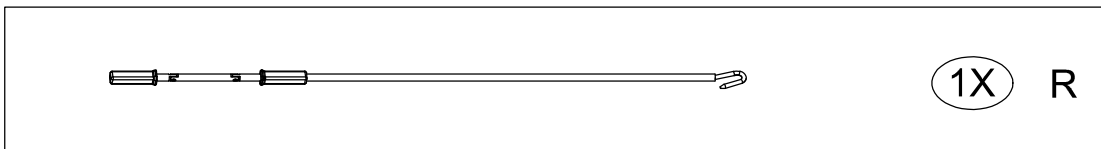

STEP 16

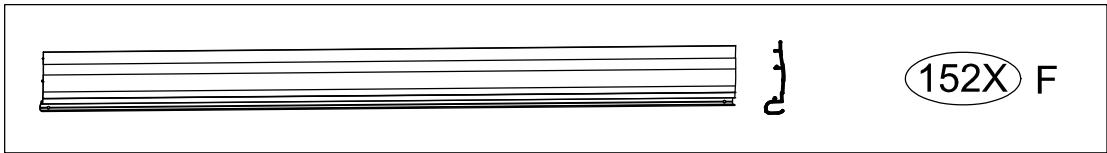
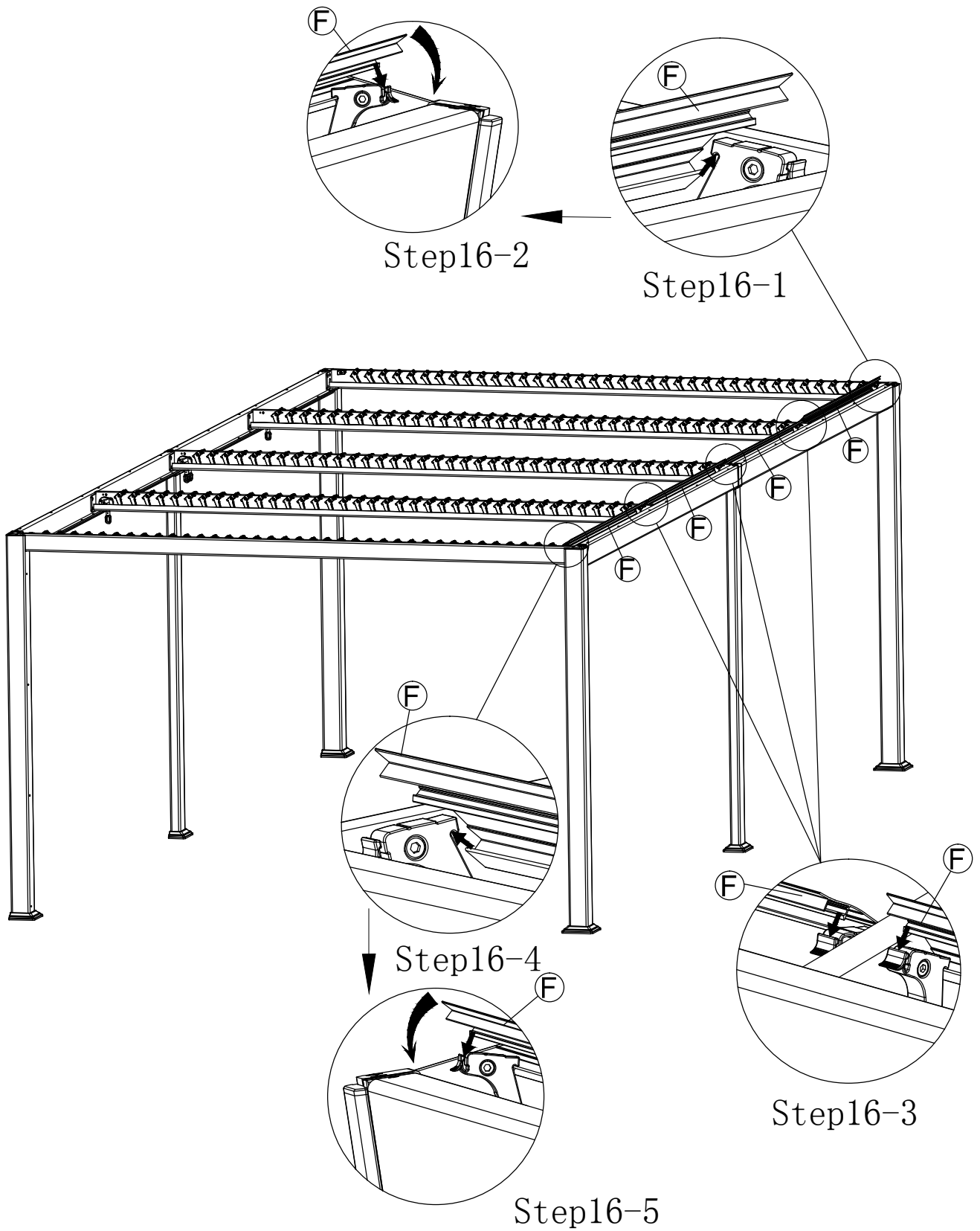

STEP 17

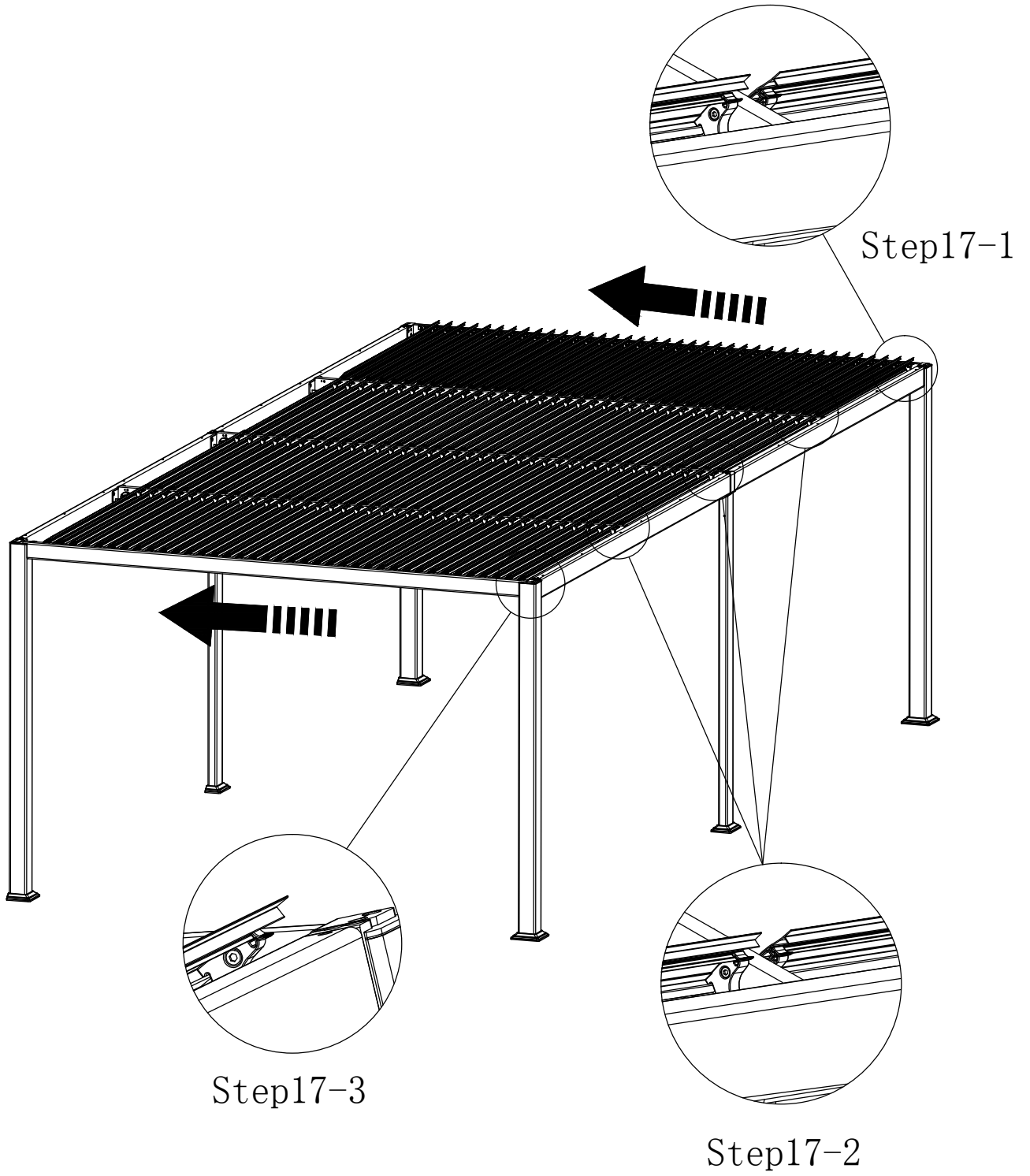

STEP 18

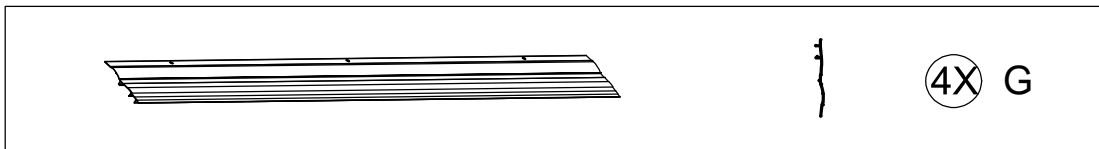
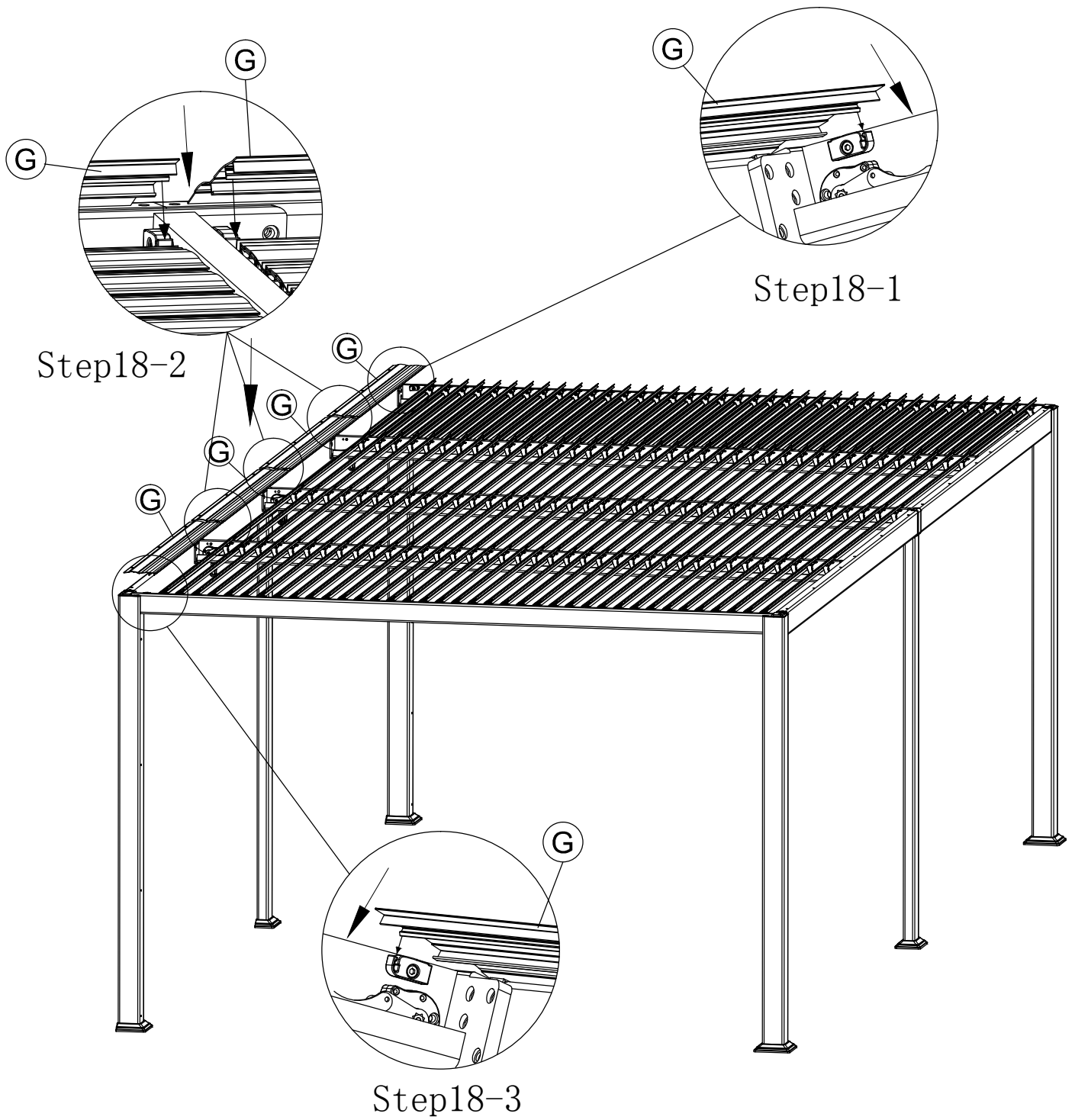

STEP 19

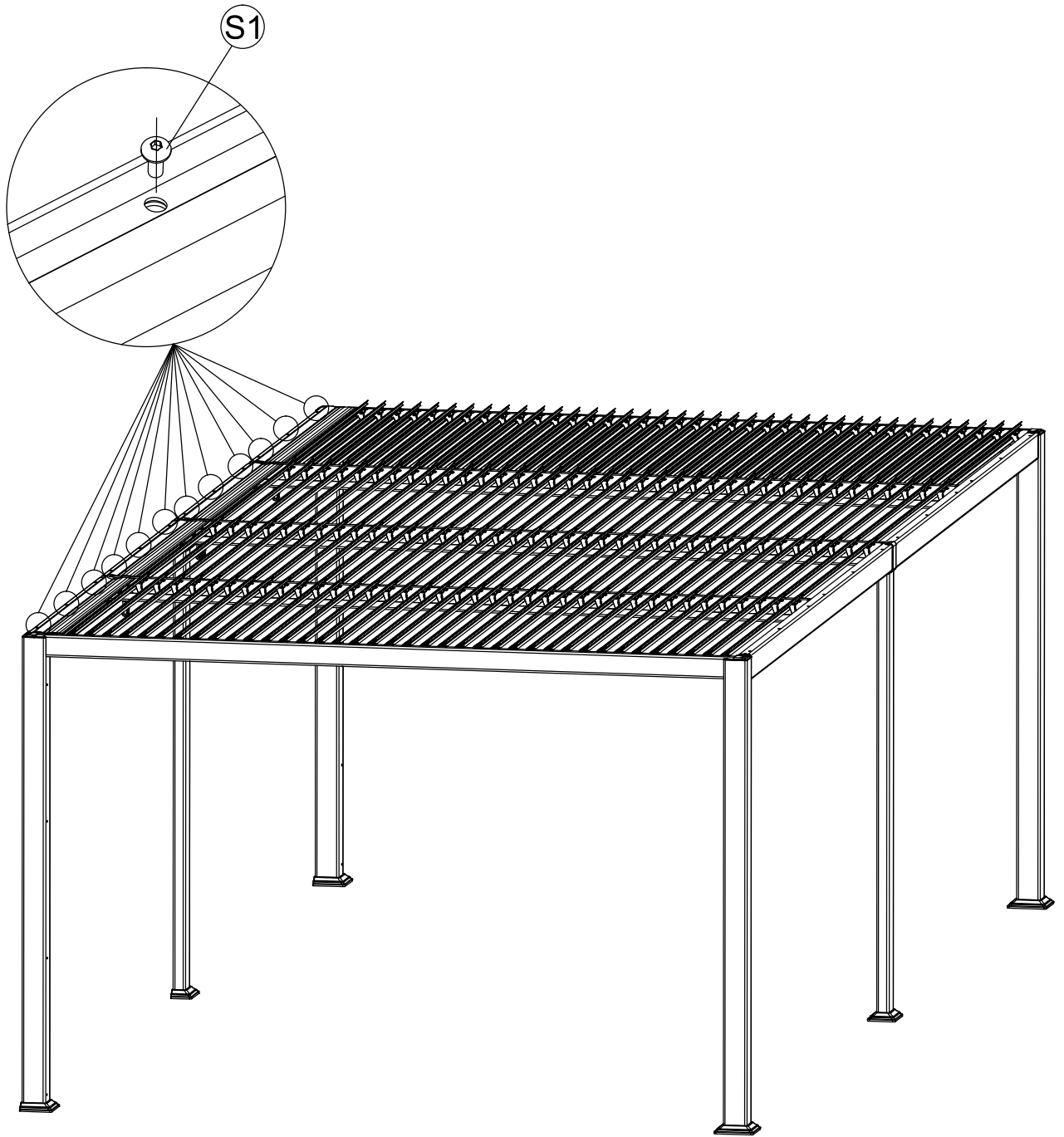

	M6*15	(12X) S1
---	-------	----------

STEP 20

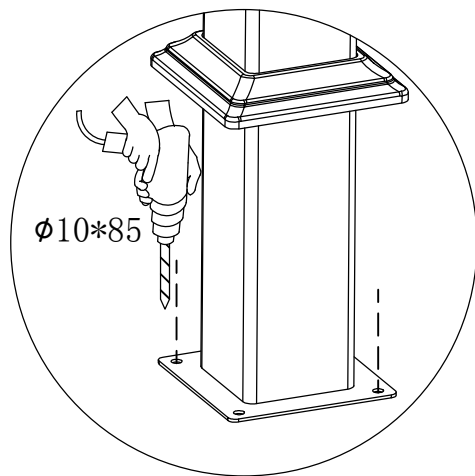
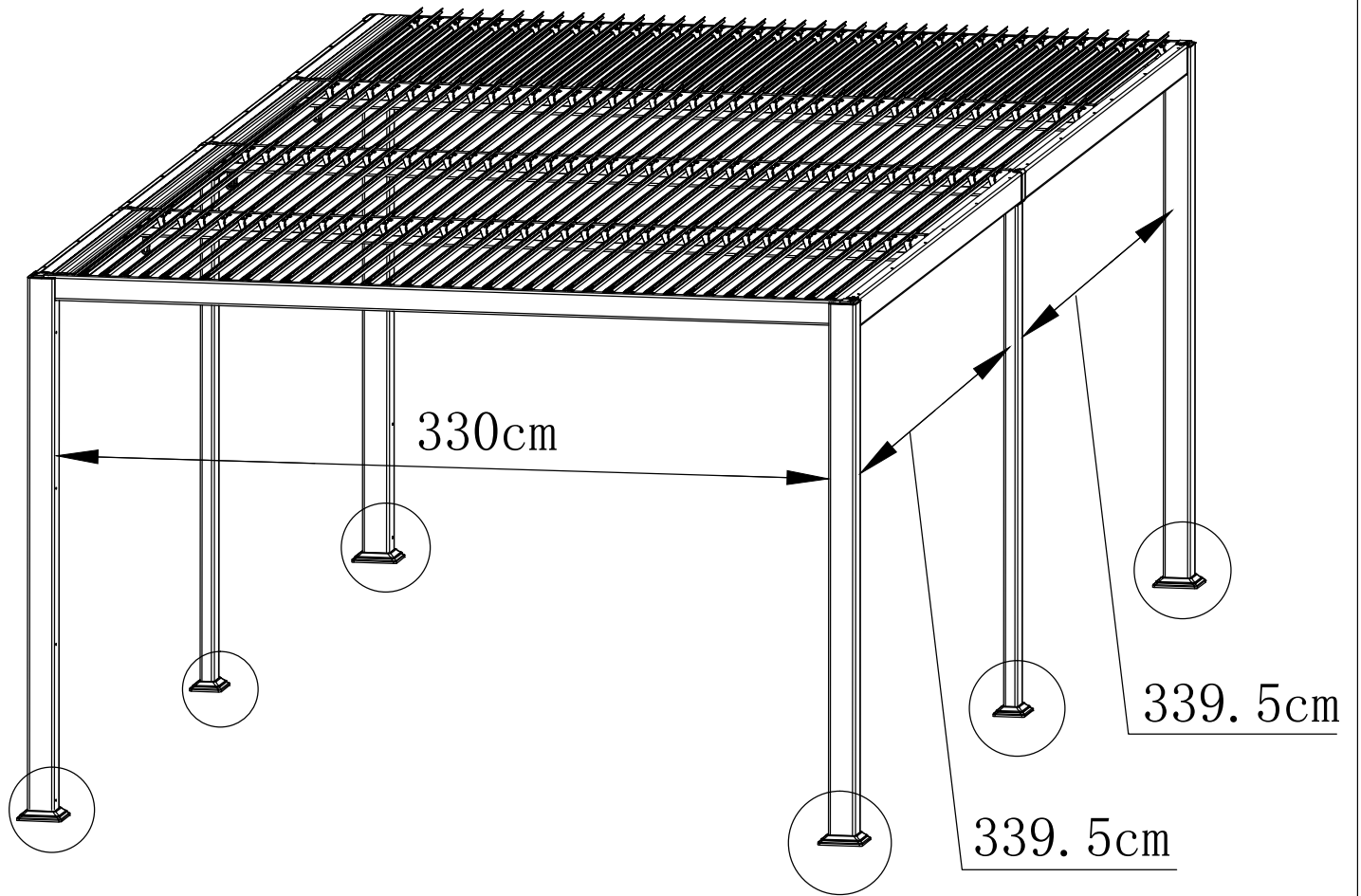

STEP 21

