

MF0ULX1

MIFARE Ultralight EV1 - Contactless ticket IC

Rev. 3.3 — 9 April 2019
234533

Product data sheet
COMPANY PUBLIC

1 General description

NXP Semiconductors developed the MIFARE Ultralight EV1 MF0ULx1 for use in a contactless smart ticket, smart card or token in combination with a Proximity Coupling Device (PCD). The MF0ULx1 is designed to work in an ISO/IEC 14443 Type A compliant environment (see [1]). The target applications include single trip or limited use tickets in public transportation networks, loyalty cards or day passes for events. The MF0ULx1 serves as a replacement for conventional ticketing solutions such as paper tickets, magnetic stripe tickets or coins. It is also a perfect ticketing counterpart to contactless card families such as MIFARE DESFire or MIFARE Plus.

The MIFARE Ultralight EV1 is succeeding the MIFARE Ultralight ticketing IC and is fully functional backwards compatible. Its enhanced feature and command set enable more efficient implementations and offer more flexibility in system designs.

The mechanical and electrical specifications of MIFARE Ultralight EV1 are tailored to meet the requirements of inlay and paper ticket manufacturers.

In this document the term „MIFARE Ultralight card“ refers to a MIFARE Ultralight IC-based contactless card.

1.1 Contactless energy and data transfer

In a contactless system, the MF0ULx1 is connected to a coil with a few turns. The MF0ULx1 fits the TFC.0 (Edmondson) and TFC.1 (ISO) ticket formats as defined in [Ref. 8](#).

The MF0ULx1 chip, which is available with 17 pF or 50 pF on-chip resonance capacitor, supports both TFC.1 and TFC.0 ticket formats.

1.2 Anticollision

An intelligent anticollision function allows more than one card to operate in the field simultaneously. The anticollision algorithm selects each card individually. It ensures that the execution of a transaction with a selected card is performed correctly without interference from another card in the field.

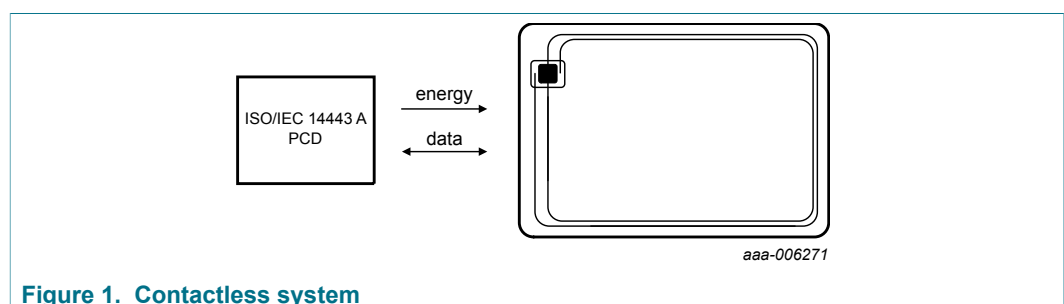

Figure 1. Contactless system

1.3 Simple integration and user convenience

The MF0ULx1 is designed for simple integration and user convenience which allows complete ticketing transactions to be handled in less than 35 ms.

1.4 Security

- Manufacturer programmed 7-byte UID for each device
- 32-bit user definable One-Time Programmable (OTP) area
- 3 independent 24-bit true one-way counters
- Field programmable read-only locking function per page (per 2 pages for the extended memory section)
- ECC based originality signature
- 32-bit password protection to prevent unintended memory operations

1.5 Naming conventions

Table 1. Naming conventions

MF0ULHx101Dyy	Description
MF	MIFARE product family
0	MIFARE Ultralight product family
UL	Product: MIFARE Ultralight
H	If present, defining high input capacitance H... 50 pF input capacitance
x	One character identifier defining the memory size 1... 640 bit total memory, 384 bit free user memory 2... 1312 bit total memory, 1024 bit free user memory
Dyy	yy defining the delivery type UF... bare die, 75 µm thickness, Au bumps, e-map file UD... bare die, 120 µm thickness, Au bumps, e-map file A8... MOA8 contactless module

2 Features and benefits

- Contactless transmission of data and supply energy
- Operating frequency of 13.56 MHz
- Data integrity of 16-bit CRC, parity, bit coding, bit counting
- 7 byte serial number (cascade level 2 according to ISO/IEC 14443-3)
- Fast counter transaction: < 10 ms
- Operating distance up to 100 mm depending on antenna geometry and reader configuration
- Data transfer of 106 kbit/s
- True anticollision
- Typical ticketing transaction: < 35 ms

2.1 EEPROM

- 640-bit or 1312-bit, organized in 20 or 41 pages with 4 bytes per page
- Field programmable read-only locking function per page for the first 512 bits
- 32-bit user definable One-Time Programmable (OTP) area
- 3 independent, true one-way 24-bit counters on top of the user area
- Configurable password protection with optional limit of unsuccessful attempts
- Data retention time of 10 years
- Write endurance for one-way counters 1.000.000 cycles
- First 512 bits compatible to MF0ICU1
- Field programmable read-only locking function per 2 pages above page 15
- 384-bit or 1024-bit freely available user Read/Write area (12 or 32 pages)
- Anti-tearing support for counters, OTP area and lock bits
- ECC based originality signature
- Write endurance 100.000 cycles

3 Applications

- Public transportation
- Event ticketing
- Loyalty

4 Quick reference data

Table 2. Quick reference data

Symbol	Parameter	Conditions	Min	Typ	Max	Unit
C _i	input capacitance MF0ULx1		[1] -	17.0	-	pF
C _i	input capacitance MF0ULHx1		[1] -	50.0	-	pF
f _i	input frequency		-	13.56	-	MHz
EEPROM characteristics						
t _{ret}	retention time	T _{amb} = 22 °C	10	-	-	year
N _{endu(W)}	write endurance	T _{amb} = 22 °C	100000	-	-	cycle
N _{endu(W)}	write endurance counters	T _{amb} = 22 °C	100000	1000000	-	cycle

[1] T_{amb} = 22 °C, f = 13.56 MHz, V_{LaB} = 1.5 V RMS

5 Ordering information

Table 3. Ordering information

Type number	Package		Version
	Name	Description	
MF0UL1101DUF	FFC Bump	8 inch wafer, 75 μm thickness, on film frame carrier, electronic fail die marking according to SECS-II format), Au bumps, 384 bit user memory, 17 pF input capacitance	-
MF0UL1101DUD	FFC Bump	8 inch wafer, 120 μm thickness, on film frame carrier, electronic fail die marking according to SECS-II format), Au bumps, 384 bit user memory, 17 pF input capacitance	-
MF0UL1101DUD2	FFC Bump	12 inch wafer, 120 μm thickness, on film frame carrier, electronic fail die marking according to SECS-II format), Au bumps, 384 bit user memory, 17 pF input capacitance	-
MF0ULH1101DUF	FFC Bump	8 inch wafer, 75 μm thickness, on film frame carrier, electronic fail die marking according to SECS-II format), Au bumps, 384 bit user memory, 50 pF input capacitance	-
MF0ULH1101DUD	FFC Bump	8 inch wafer, 120 μm thickness, on film frame carrier, electronic fail die marking according to SECS-II format), Au bumps, 384 bit user memory, 50 pF input capacitance	-
MF0UL2101DUF	FFC Bump	8 inch wafer, 75 μm thickness, on film frame carrier, electronic fail die marking according to SECS-II format), Au bumps, 1024 bit user memory, 17 pF input capacitance	-
MF0UL2101DUD	FFC Bump	8 inch wafer, 120 μm thickness, on film frame carrier, electronic fail die marking according to SECS-II format), Au bumps, 1024 bit user memory, 17 pF input capacitance	-
MF0UL2101DUD2	FFC Bump	12 inch wafer, 120 μm thickness, on film frame carrier, electronic fail die marking according to SECS-II format), Au bumps, 1024 bit user memory, 17 pF input capacitance	-
MF0ULH2101DUF	FFC Bump	8 inch wafer, 75 μm thickness, on film frame carrier, electronic fail die marking according to SECS-II format), Au bumps, 1024 bit user memory, 50 pF input capacitance	-
MF0ULH2101DUD	FFC Bump	8 inch wafer, 120 μm thickness, on film frame carrier, electronic fail die marking according to SECS-II format), Au bumps, 1024 bit user memory, 50 pF input capacitance	-
MF0UL2101DA8	MOA8	plastic lead less module carrier package; 35 mm wide tape, 1024 bit user memory, 17 pF input capacitance	SOT500-4

6 Block diagram

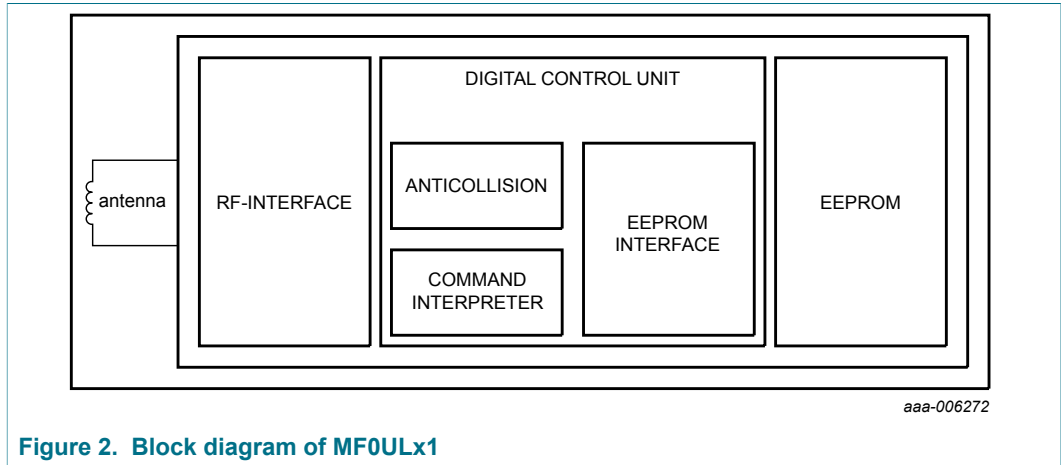

Figure 2. Block diagram of MF0ULx1

7 Pinning information

7.1 Pinning

The pinning for the MF0ULx1DAX is shown [Figure 3](#) for a contactless MOA8 module.

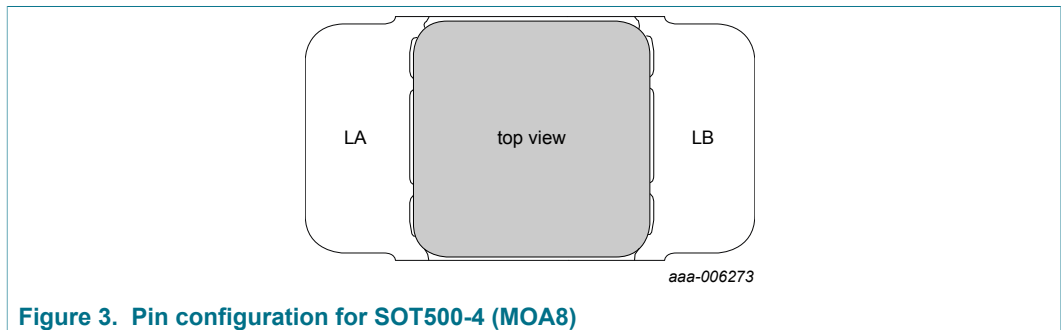

Figure 3. Pin configuration for SOT500-4 (MOA8)

Table 4. Pin allocation table

Pin	Symbol	
LA	LA	antenna coil connection LA
LB	LB	antenna coil connection LB

8 Functional description

8.1 Block description

The MF0ULx1 chip consists of a 640-bit or a 1312-bit EEPROM, RF interface and Digital Control Unit (DCU). Energy and data are transferred via an antenna consisting of a coil with a few turns which is directly connected to the MF0ULx1. No further external components are necessary. Refer to [Ref. 2](#) for details on antenna design.

- RF interface:
 - modulator/demodulator
 - rectifier
 - clock regenerator
 - Power-On Reset (POR)
 - voltage regulator
- Anticollision: multiple cards may be selected and managed in sequence
- Command interpreter: processes memory access commands that the MF0ICU1 supports
- EEPROM interface
- EEPROM: 640 bit, organized in 20 pages of 4 byte per page.
 - 208 bit reserved for manufacturer and configuration data
 - 16 bit used for the read-only locking mechanism
 - 32 bit available as OTP area
 - 384 bit user programmable read/write memory
- EEPROM: 1312 bit, organized in 41 pages of 4 byte per page.
 - 208 bit reserved for manufacturer and configuration data
 - 31 bit used for the read-only locking mechanism
 - 32 bit available as OTP area
 - 1024 bit user programmable read/write memory

8.2 RF interface

The RF-interface is based on the ISO/IEC 14443 Type A standard for contactless smart cards.

During operation, the reader generates an RF field. This RF field must always be present (with short pauses for data communication), as it is used for the power supply of the card.

For both directions of data communication, there is one start bit at the beginning of each frame. Each byte is transmitted with an odd parity bit at the end. The LSB of the byte with the lowest address of the selected block is transmitted first. The maximum length of a PCD to PICC frame is 208 bits (21 data bytes + 2 CRC bytes = $20 \times 9 + 2 \times 9 + 1$ start bit). The maximum length for a fixed size PICC to PCD frame is 307 bits (32 data bytes + 2 CRC bytes = $32 \times 9 + 2 \times 9 + 1$ start bit). The FAST_READ response has a variable frame length depending on the start and end address parameters. When issuing this command, take into account the maximum frame length that the PCD supports.

For a multi-byte parameter, the least significant byte is always transmitted first. As an example, take reading from the memory using the READ command. Byte 0 from the addressed block is transmitted first after which, byte 1 to byte 3 are transmitted. The same sequence continues for the next block and all subsequent blocks.

8.3 Data integrity

Following mechanisms are implemented in the contactless communication link between reader and card to ensure very reliable data transmission:

- 16 bits CRC per block
- parity bits for each byte
- bit count checking
- bit coding to distinguish between "1", "0" and "no information"
- channel monitoring (protocol sequence and bit stream analysis)

8.4 Communication principle

The reader initiates the commands and the Digital Control Unit of the MF0ULx1 controls them. The command response is depending on the state of the IC and for memory operations also on the access conditions valid for the corresponding page.

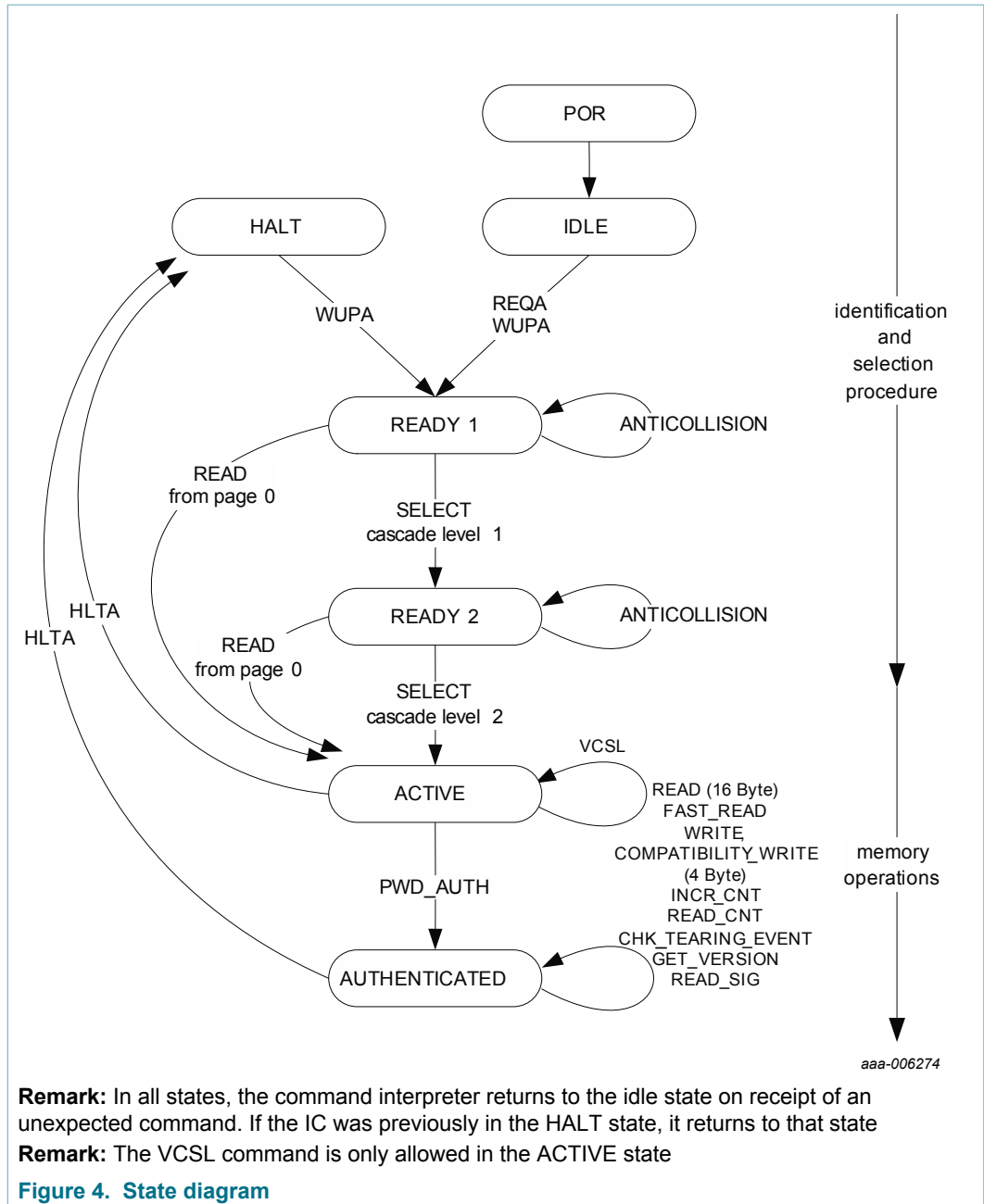

8.4.1 IDLE state

After a power-on reset (POR), the MF0ULx1 switches to the IDLE state. It only exits this state when a REQA or a WUPA command is received from the PCD. Any other data received while in this state is interpreted as an error and the MF0ULx1 remains in the IDLE state.

Refer to [Ref. 4](#) for implementation hints for a card polling algorithm that respects relevant timing specifications from ISO/IEC 14443 Type A.

After a correctly executed HLTA command, for example out of the ACTIVE or AUTHENTICATED state, the default waiting state changes from IDLE to HALT. This state can then be exited with a WUPA command only.

8.4.2 READY1 state

In this state, the PCD resolves the first part of the UID (3 bytes) using the ANTICOLLISION or SELECT commands in cascade level 1. This state is exited correctly after execution of either of the following commands:

- SELECT command from cascade level 1: the PCD switches the MF0ULx1 into READY2 state where the second part of the UID is resolved.
- READ command (from address 0): all anticollision mechanisms are bypassed and the MF0ULx1 switches directly to the ACTIVE state.

Remark: If more than one MF0ULx1 is in the PCD field, a READ command from address 0 selects all MF0ULx1 devices. In this case, a collision occurs due to the different serial numbers. Any other data received in the READY1 state is interpreted as an error. Depending on its previous state, the MF0ULx1 returns to either the IDLE state or HALT state.

8.4.3 READY2 state

In this state, the MF0ULx1 supports the PCD in resolving the second part of its UID (4 bytes) with the cascade level 2 ANTICOLLISION command. This state is usually exited using the cascade level 2 SELECT command.

Alternatively, READY2 state can be skipped using a READ command (from address 0) as described for the READY1 state.

Remark: The response of the MF0ULx1 to the cascade level 2 SELECT command is the select acknowledge (SAK) byte. In accordance with ISO/IEC 14443, this byte indicates if the anticollision cascade procedure has finished. It also defines the type of device selected for the MIFARE product architecture platform. The MF0ULx1 is now uniquely selected and only this device communicates with the PCD even when other contactless devices are present in the PCD field. If more than one MF0ULx1 is in the PCD field, a READ command from address 0 selects all MF0ULx1 devices. In this case, a collision occurs due to the different serial numbers. Any other data received when the device is in this state is interpreted as an error. Depending on its previous state the MF0ULx1 returns to either the IDLE state or HALT state.

8.4.4 ACTIVE state

All memory operations and other functions like the originality signature read-out are operated in the ACTIVE state.

The ACTIVE state is gracefully exited with the HLTA command and upon reception the MF0ULx1 transits to the HALT state. Any other data received when the device is in this state is interpreted as an error. Depending on its previous state the MF0ULx1 returns to either the IDLE state or HALT state.

The MF0ULx1 transits to the AUTHENTICATED state after successful password verification using the PWD_AUTH command.

8.4.5 AUTHENTICATED state

In this state, all operations on memory pages, which are configured as password verification protected, can be accessed.

The AUTHENTICATED state is gracefully exited with the HLTA command and upon reception the MF0ULx1 transits to the HALT state. Any other data received when the

device is in this state is interpreted as an error. Depending on its previous state the MFOULx1 returns to either the IDLE state or HALT state.

8.4.6 HALT state

The HALT and IDLE states constitute the two wait states implemented in the MFOULx1. An already processed MFOULx1 can be set into the HALT state using the HLTA command. In the anticollision phase, this state helps the PCD to distinguish between processed cards and cards yet to be selected. The MFOULx1 can only exit this state on execution of the WUPA command. Any other data received when the device is in this state is interpreted as an error and the MFOULx1 state remains unchanged. Refer to [Ref. 4](#) for correct implementation of an anticollision procedure based on the IDLE and HALT states and the REQA and WUPA commands.

8.5 Memory organization

The EEPROM memory is organized in pages with 4 bytes per page. The MFOUL11 variant has 20d pages and the MFOUL21 variant has 41d pages in total. The memory organization can be seen in [Figure 5](#) and [Figure 6](#), the functionality of the different memory sections is described in the following sections.

Page Adr		Byte number within a page				Description
Dec	Hex	0	1	2	3	
0	0h	serial number				Manufacturer data and lock bytes
1	1h	serial number				
2	2h	serial number	internal	lock bytes		One Time Programmable
3	3h	OTP	OTP	OTP	OTP	
4	4h	user memory				User memory pages
5	5h					
...	...					
14	Eh					
15	Fh	CFG0				Configuration pages
16	10h					
17	11h					
18	12h	PWD				Counter pages
19	13h	PACK		RFUI		
		One-Way counters ¹⁾				

aaa-006275

1. counter pages are only accessible with READ_CNT and INCR_CNT commands

Figure 5. Memory organization MFOUL11

Page Adr		Byte number within a page				Description
Dec	Hex	0	1	2	3	
0	0h	serial number				Manufacturer data and lock bytes
1	1h	serial number				
2	2h	serial number	internal	lock bytes		One Time Programmable
3	3h	OTP	OTP	OTP	OTP	
4	4h	user memory				User memory pages
5	5h					
...	...					
34	22h					
35	23h					
36	24h	lock bytes		RFUI		Lock bytes
37	25h	CFG0				Configuration pages
38	26h	CFG1				
39	27h	PWD				
40	28h	PACK		RFUI		
		one-way counters ¹⁾				Counter pages

aaa-006276

1. counter pages are only accessible with READ_CNT and INCR_CNT commands

Figure 6. Memory organization MF0UL21

8.5.1 UID/serial number

The unique 7-byte serial number (UID) and its two check bytes are programmed into the first 9 bytes of memory covering page addresses 00h, 01h and the first byte of page 02h. The second byte of page address 02h is reserved for internal data. These bytes are programmed and write protected in the production test.

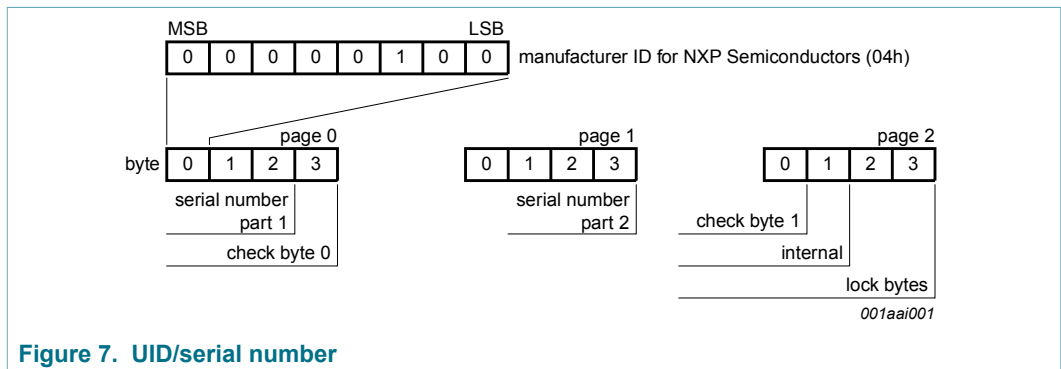

Figure 7. UID/serial number

In accordance with ISO/IEC 14443-3 check byte 0 (BCC0) is defined as $CT \oplus SN0 \oplus SN1 \oplus SN2$. Check byte 1 (BCC1) is defined as $SN3 \oplus SN4 \oplus SN5 \oplus SN6$.

SN0 holds the Manufacturer ID for NXP Semiconductors (04h) in accordance with ISO/IEC 14443-3 and ISO/IEC 7816-6 AMD.1

8.5.2 Lock byte 0 and byte 1

The bits of byte 2 and byte 3 of page 02h represent the field programmable read-only locking mechanism. Each page from 03h (OTP) to 0Fh can be individually locked by setting the corresponding locking bit Lx to logic 1 to prevent further write access. After locking, the corresponding page becomes read-only memory.

The three least significant bits of lock byte 0 are the block-locking bits. Bit 2 deals with pages 0Ah to 0Fh, bit 1 deals with pages 04h to 09h and bit 0 deals with page 03h (OTP). Once the block-locking bits are set, the locking configuration for the corresponding memory area is frozen.

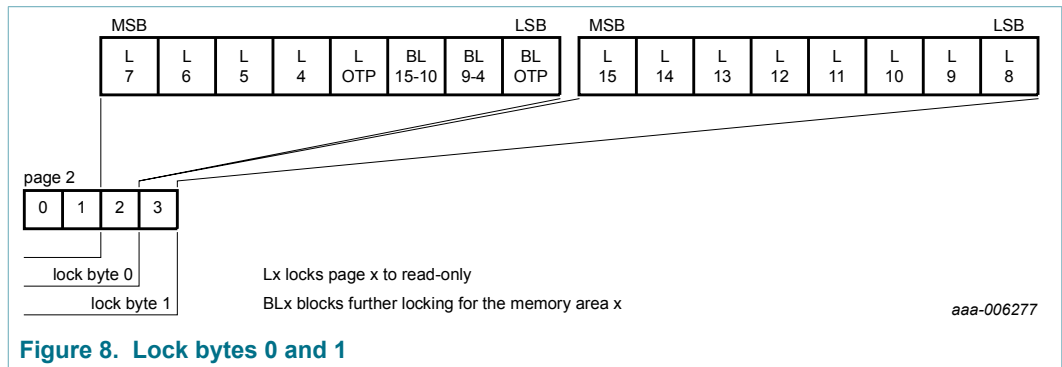

Figure 8. Lock bytes 0 and 1

For example if BL15-10 is set to logic 1, then bits L15 to L10 (lock byte 1, bit[7:2]) can no longer be changed. A WRITE command or COMPATIBILITY_WRITE command to page 02h, sets the locking and block-locking bits. Byte 2 and byte 3 of the WRITE or COMPATIBILITY_WRITE command, and the contents of the lock bytes are bit-wise OR'ed and the result then becomes the new content of the lock bytes. This process is irreversible. If a bit is set to logic 1, it cannot be changed back to logic 0.

The contents of bytes 0 and 1 of page 02h are unaffected by the corresponding data bytes of the WRITE or COMPATIBILITY_WRITE command.

The default value of the static lock bytes is 00 00h.

Any write operation to the lock bytes 0 and 1, features anti-tearing support.

Remark: Setting a lock bit to 1 immediately prevents write access to the respective page

8.5.3 Lock byte 2 to byte 4

To lock the pages of the MF0UL21 starting at page address 10h onwards, the lock bytes 2-4 located in page 24h are used. Those three lock bytes cover the memory area of 80 data bytes. The granularity is 2 pages, compared to a single page for the first 512 bits as shown in Figure 9.

Remark: Set all bits marked with RFUI to 0, when writing to the lock bytes.

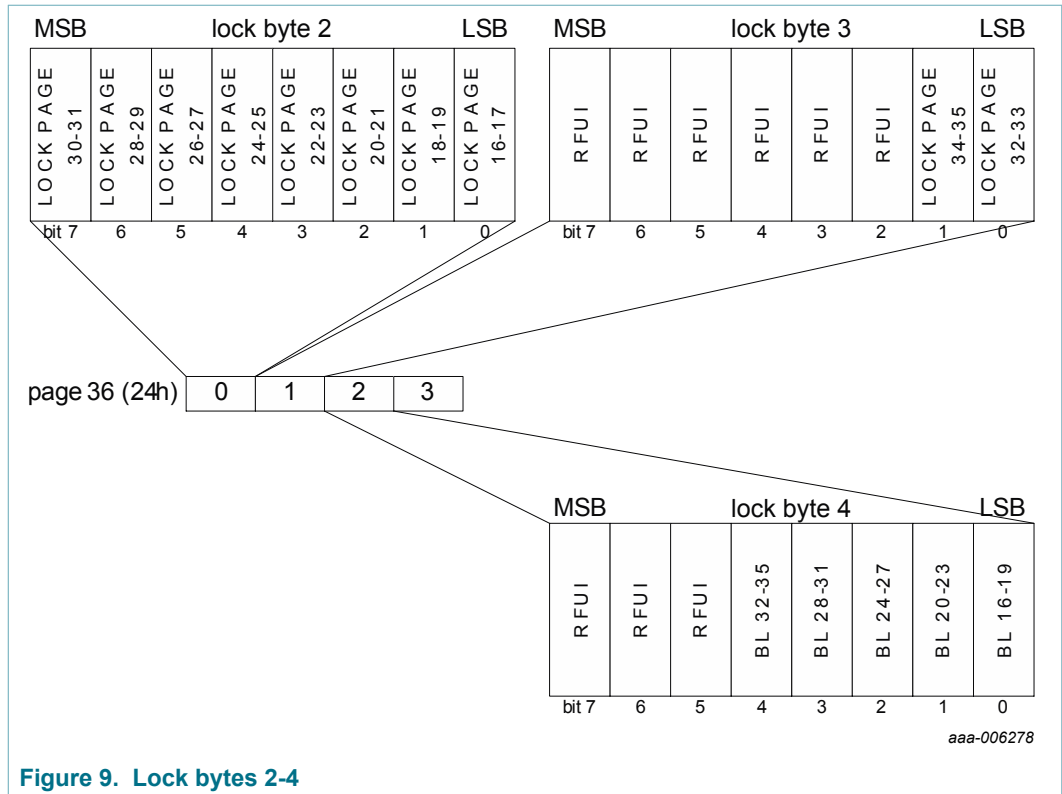

Figure 9. Lock bytes 2-4

The default value of lock bytes 2-4 is 00 00 00h. The value of byte 3 on page 36 (see Figure 9) is always BDh when read.

Any write operation to the lock bytes 2-4, features anti-tearing support.

Remark: Setting a lock bit to 1 immediately prevents write access to the respective pages

8.5.4 OTP bytes

Page 03h is the OTP page and it is preset so that all bits are set to logic 0 after production. These bytes can be bit-wise modified using the WRITE or COMPATIBILITY_WRITE command.

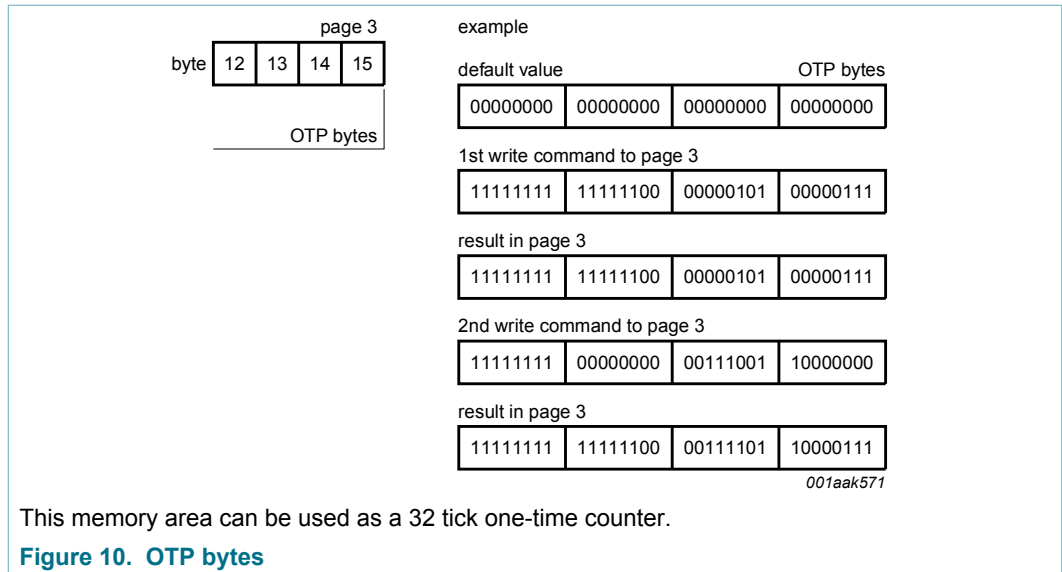

The parameter bytes of the WRITE command and the current contents of the OTP bytes are bit-wise OR'ed. The result is the new OTP byte contents. This process is irreversible and once a bit is set to logic 1, it cannot be changed back to logic 0.

The default value of the OTP bytes is 00 00 00 00h.

Any write operation to the OTP bytes features anti-tearing support.

8.5.5 Data pages

Pages 04h to 0Fh for the MF0UL11 and 04h to 23h for the MF0UL21 are the user memory read/write area.

The access to a part of the user memory area can be restricted using a password verification. See [Section 8.6](#) for further details.

Remark: The default content of the data blocks at delivery is not defined.

8.5.6 Configuration pages

Pages 10h-13h for the MF0UL11 and pages 25h-28h for the MF0UL21 variant, are used to configure the memory access restriction of the MF0ULx1. They are also used to configure the response to a VCSL command. The memory content of the configuration pages is detailed in [Table 5](#), [Table 7](#) and [Table 8](#).

Table 5. Configuration Pages

Page Address		Byte number			
Dec	Hex	0	1	2	3
16/37	10h/25h	MOD	RFUI	RFUI	AUTH0
17/38	11h/26h	ACCESS	VCTID	RFUI	RFUI
18/39	12h/27h	PWD			
19/40	13h/28h	PACK		RFUI	RFUI

1. page address for MF0UL11/MF0UL21

Table 6. MOD configuration byte

Bit number							
7	6	6	4	3	2	1	0
RFUI					STRG_MOD_EN	RFUI	

Table 7. ACCESS configuration byte

Bit number							
7	6	6	4	3	2	1	0
PROT	CFGLCK	RFUI			AUTHLIM		

Table 8. Configuration parameter descriptions

Field	Bit	Default Value	Description
STRG_MOD_EN	1	0b/1b ^[1]	STRG MOD_EN defines the modulation mode 0b ... strong modulation mode disabled 1b ... strong modulation mode enabled
AUTH0	8	FFh	AUTH0 defines the page address from which the password verification is required. Valid address range for byte AUTH0 is 00h to FFh. If AUTH0 is set to a page address which is higher than the last user configuration page, the password protection is effectively disabled.
PROT	1	0b	One bit inside the ACCESS byte defining the memory protection 0b ... write access is protected by the password verification 1b ... read and write access is protected by the password verification
CFGLCK	1	0b	Write locking bit for the user configuration 0b ... user configuration open to write access 1b ... user configuration permanently locked against write access
AUTHLIM	3	000b	Limitation of negative password verification attempts 000b... limiting of negative password verification attempts disabled 001b-111b ... maximum number of negative password verification attempts
VCTID	8	05h	Virtual Card Type Identifier which represents the response to a VCSL command. To ensure infrastructure compatibility, it is recommended not to change the default value of 05h.
PWD	32	FFFF FFFFh	32-bit password used for memory access protection
PACK	16	0000h	16-bit password acknowledge used during password verification
RFUI	-	all 0b	Reserved for future use - implemented. Write all bits and bytes denoted as RFUI as 0b.

[1] Values for MF0ULX1/MF0ULHX1. The STRG_MOD_EN feature is only available on the high capacitance variants MF0ULHX1 types. For the MF0ULX1 types, this bit is set to 0b and only the strong modulator is available.

Remark: The CFGLCK bit activates the permanent write protection of the first two configuration pages. The write lock is only activated after a power cycle of the MF0ULX1. If write protection is enabled, each write attempt leads to a NAK response.

8.6 Password verification protection

The memory write or read/write access to a configurable part of the memory can be constrained to a positive password verification. The 32-bit secret password (PWD) and the 16-bit password acknowledge (PACK) are typically programmed into the configuration pages at ticket issuing or personalization. The use of a chip individual password acknowledge response raises the trust level on the PCD side into the PICC.

The AUTHLIM parameter specified in [Section 8.5.6](#) can be used to limit the negative verification attempts.

In the initial state of the MF0ULx1, an AUTH0 value of FFh disables password protection. PWD and PACK are freely writable in this state. Access to the configuration pages and any part of the user memory, can be restricted by setting AUTH0 a page address within the available memory space. The page address is the first one protected.

Remark: Note that the password verification method available in then MF0ULx1 does not offer a high security protection. It is an easy and convenient way to prevent unauthorized memory access. If a higher level of protection is required, cryptographic methods on application layer can be used to increase overall system security.

8.6.1 Programming of PWD and PACK

Program the 32-bit PWD and the 16-bit PACK into the configuration pages, see [Section 8.5.6](#). The password as well as the password acknowledge, are written LSByte first. This byte order is the same as the byte order used during the PWD_AUTH command and its response.

The PWD and PACK bytes can never be read out of the memory. Instead of transmitting the real value on any valid READ or FAST_READ command, only 00h bytes are replied.

If the password verification does not protect the configuration pages, PWD and PACK can be written with normal WRITE and COMPATIBILITY_WRITE commands.

If the password verification protects the configuration pages, PWD and PACK can only be written after a successful PWD_AUTH command.

The PWD and PACK are writable even if the CFGLCK bit is set to 1b. Therefore it is strongly recommended to set AUTH0 to the page where the PWD is located after the password has been written. This page is 12h for the MF0UL11 and 27h for the MF0UL21.

Remark: To improve the overall system security, it is strongly recommended to diversify the password and the password acknowledge using a die individual parameter, that is, the 7-byte UID available on the MF0ULx1.

8.6.2 Limiting negative verification attempts

To prevent brute-force attacks on the password, the maximum allowed number of negative password verification attempts can be set using AUTHLIM. This mechanism is disabled by setting AUTHLIM to a value of 000b which is also the initial state of the MF0ULx1.

If AUTHLIM is not equal to 000b, each negative authentication verification is internally counted. The count operation features anti-tearing support. As soon as this internal counter reaches the number specified in AUTHLIM, any further negative password verification leads to a permanent locking of the protected part of the memory for the specified access modes. Independent, whether the provided password is correct or not, each subsequent PWD_AUTH fails.

Any successful password verification, before reaching the limit of negative password verification attempts, resets the internal counter to zero.

8.6.3 Protection of special memory segments

The configuration pages can be protected by the password authentication as well. The protection level is defined with the PROT bit.

The protection is enabled by setting the AUTH0 byte to a value that is within the addressable memory space.

All counters can always be incremented and read without prior password verification.

8.7 Counter functionality

The MF0ULx1 features three independent 24-bit one-way counters. These counters are located in a separate part of the NVM which is not directly addressable using READ, FAST_READ, WRITE or COMPATIBILITY_WRITE commands. The actual value can be retrieved by using the READ_CNT command, the counters can be incremented with the INCR_CNT command. The INCR_CNT command features anti-tearing support, thus no undefined values originating from interrupted programming cycles are possible. Either the value is unchanged or the correct, incremented value is correctly programmed into the counter. The occurrence of a tearing event can be checked using the CHECK_TEARING_EVENT command.

In the initial state, the counter values are set to 000000h.

The counters can be incremented by an arbitrary value. The incremented value is valid immediately and does not require a RF reset or re-activation. Once counter value reaches FFFFFFFh and an increment is performed via a valid INCR_CNT command, the MF0ULx1 replies a NAK. If the sum of the addressed counter value and the increment value in the INCR_CNT command is higher than FFFFFFFh, the MF0ULx1 replies a NAK and does not update the respective counter.

An increment by zero (000000h) is always possible, but does not have any impact on the counter value.

8.8 Originality function

The MF0ULx1 features a cryptographically supported originality check. With this feature, it is possible to verify with a certain probability, that the ticket is using an NXP Semiconductors manufactured silicon. This check can also be performed on personalized tickets.

Each MF0ULx1 holds a 32-byte cryptographic signature based on elliptic curve cryptography. This signature can be retrieved using the READ_SIG command and can be verified using the corresponding ECC public key in the PCD.

8.9 Virtual Card Architecture Support

The MF0ULx1 supports the virtual card architecture by replying to a Virtual Card Select Last (VCSL) command with a virtual card type identifier. The VCTID that is replied can be programmed in the configuration pages. It enables infrastructure supporting this feature to process MIFARE product-based cards across different MIFARE families in a common way.

For example, a contactless system is enabled to select a specific virtual MIFARE product-based card inside a mobile phone. It can use the same card identification principle to detect that the MF0ULx1 belongs to the system.

9 Command overview

The MIFARE Ultralight card activation follows the ISO/IEC 14443 Type A. After the MIFARE Ultralight card has been selected, it can either be deactivated using the ISO/IEC 14443 HLTA command, or the MIFARE Ultralight commands can be performed. For more details about the card activation, refer to [Ref. 1](#).

9.1 MIFARE Ultralight EV1 command overview

All available commands for the MIFARE Ultralight are shown in [Table 9](#).

Table 9. Command overview

Command ^[1]	ISO/IEC 14443	Command code (hexadecimal)
Request	REQA	26h (7 bit)
Wake-up	WUPA	52h (7 bit)
Anticollision CL1	Anticollision CL1	93h 20h
Select CL1	Select CL1	93h 70h
Anticollision CL2	Anticollision CL2	95h 20h
Select CL2	Select CL2	95h 70h
Halt	HLTA	50h 00h
GET_VERSION ^[2]	-	60h
READ	-	30h
FAST_READ ^[2]	-	3Ah
WRITE	-	A2h
COMP_WRITE	-	A0h
READ_CNT ^[2]	-	39h
INCR_CNT ^[2]	-	A5h
PWD_AUTH ^[2]	-	1Bh
READ_SIG ^[2]	-	3Ch
CHECK_TEARING_EVENT ^[2]	-	3Eh
VCSL ^[2]	-	4Bh

[1] Unless otherwise specified, all commands use the coding and framing as described in [Ref. 1](#).

[2] this command is new in MIFARE Ultralight EV1 compared to MIFARE Ultralight

9.2 Timing

The command and response timings shown in this document are not to scale and values are rounded to 1 μ s.

All given command and response transmission times refer to the data frames including start of communication and end of communication. A PCD data frame, contains the start of communication (1 "start bit") and the end of communication (one logic 0 + 1 bit length of unmodulated carrier). A PICC data frame, contains the start of communication (1 "start bit") and the end of communication (1 bit length of no subcarrier).

The minimum command response time is specified according to Ref. 1 as an integer *n* which specifies the PCD to PICC frame delay time. The frame delay time from PICC to PCD has a minimum *n* of 9. The maximum command response time is specified as a time-out value. Depending on the command, the *T_{ACK}* value specified for command responses defines the PCD to PICC frame delay time. It does it for either the 4-bit ACK value specified in Section 9.3 or for a data frame.

All command timings are according to ISO/IEC 14443-3 frame specification as shown for the Frame Delay Time in Figure 11. For more details, refer to Ref. 1.

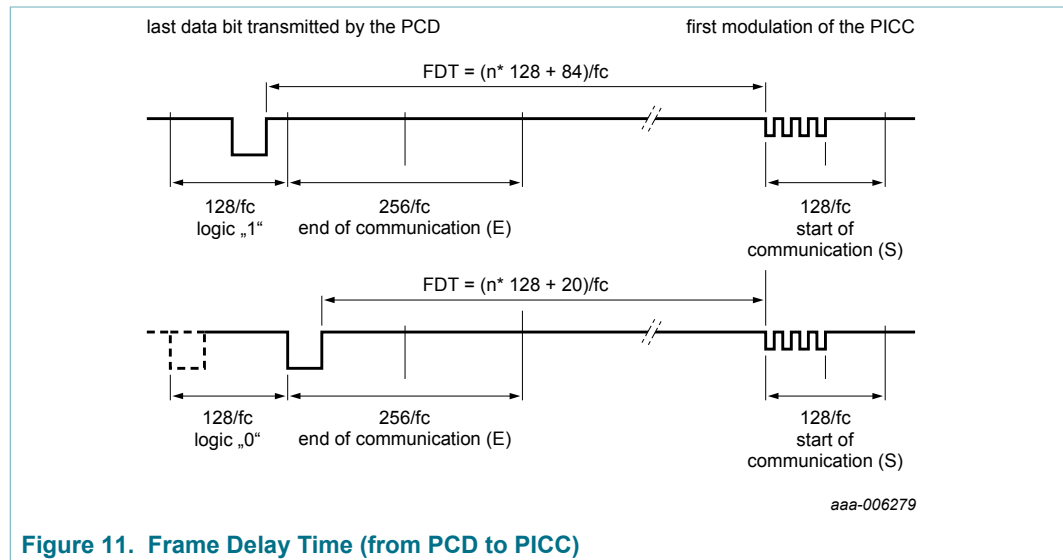

Figure 11. Frame Delay Time (from PCD to PICC)

Remark: Due to the coding of commands, the measured timings usually excludes (a part of) the end of communication. Consider this factor when comparing the specified times with the measured times.

9.3 MIFARE Ultralight ACK and NAK

The MIFARE Ultralight uses a 4-bit ACK / NAK as shown in Table 10.

Table 10. ACK and NAK values

Code (4-bit)	ACK/NAK
Ah	Acknowledge (ACK)
0h	NAK for invalid argument (i.e. invalid page address)
1h	NAK for parity or CRC error
4h	NAK for counter overflow
5h, 7h	NAK for EEPROM write error
6h, 9h	NAK, other error

9.4 ATQA and SAK responses

For details on the type identification procedure, refer to [Ref. 3](#).

The MF0ULx1 replies to a REQA or WUPA command with the ATQA value shown in [Table 11](#). It replies to a Select CL2 command with the SAK value shown in [Table 12](#). The 2-byte ATQA value is transmitted with the least significant byte first (44h).

Table 11. ATQA response of the MF0ULx1

Sales type	Hex value	Bit number																
		16	15	14	13	12	11	10	9	8	7	6	5	4	3	2	1	
MF0ULx1	00 44h	0	0	0	0	0	0	0	0	0	0	1	0	0	0	1	0	0

Table 12. SAK response of the MF0ULx1

Sales type	Hex value	Bit number							
		8	7	6	5	4	3	2	1
MF0ULx1	00h	0	0	0	0	0	0	0	0

Remark: The ATQA coding in bits 7 and 8 indicate the UID size according to ISO/IEC 14443 independent from the settings of the UID usage.

Remark: The bit numbering in the ISO/IEC 14443 starts with LSB = bit 1 and not with LSB = bit 0. So 1 byte counts bit 1 to bit 8 instead of bit 0 to 7.

10 MIFARE Ultralight EV1 commands

10.1 GET_VERSION

The GET_VERSION command is used to retrieve information on the MIFARE family, product version, storage size and other product data required to identify the MF0ULx1.

This command is available on other MIFARE products to have a common way of identifying products across platforms and evolution steps.

The GET_VERSION command has no arguments and replies the version information for the specific MF0ULx1 type. The command structure is shown in [Figure 12](#) and [Table 13](#).

[Table 14](#) shows the required timing.

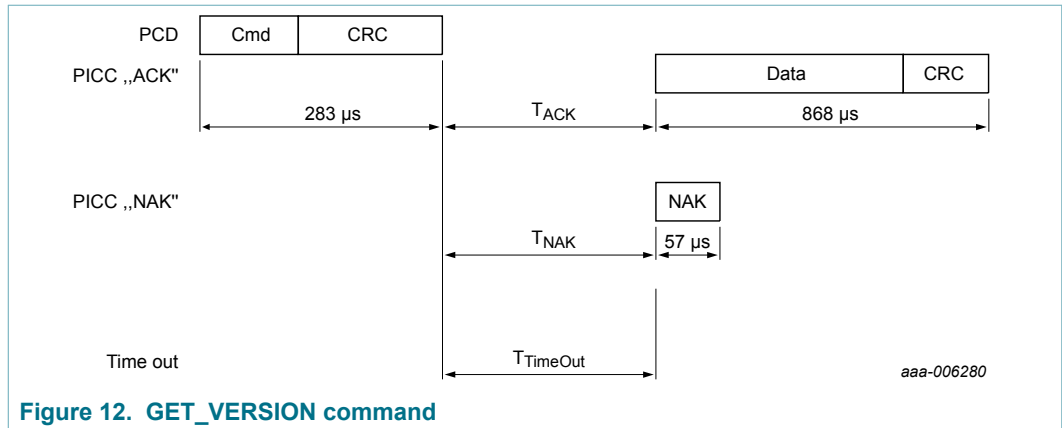

Figure 12. GET_VERSION command

Table 13. GET_VERSION command

Name	Code	Description	Length
Cmd	60h	Get product version	1 byte
CRC	-	CRC according to Ref. 1	2 bytes
Data	-	Product version information	8 bytes
NAK	see Table 10	see Section 9.3	4-bit

Table 14. GET_VERSION timing

These times exclude the end of communication of the PCD.

	T _{ACK min}	T _{ACK max}	T _{NAK min}	T _{NAK max}	T _{TimeOut}
GET_VERSION	n=9	T _{TimeOut}	n=9	T _{TimeOut}	5 ms

Table 15. GET_VERSION response for MF0UL11 and MF0UL21

Byte no.	Description	MF0UL11/ MF0ULH11	MF0UL21/ MF0ULH21	Interpretation
0	fixed header	00h	00h	
1	vendor ID	04h	04h	NXP Semiconductors
2	product type	03h	03h	MIFARE Ultralight
3	product subtype	01h/02h	01h/02h	17 pF / 50pF
4	major product version	01h	01h	EV1
5	minor product version	00h	00h	V0
6	storage size	0Bh	0Eh	see following explanation
7	protocol type	03h	03h	ISO/IEC 14443-3 compliant

The most significant 7 bits of the storage size byte are interpreted as an unsigned integer value n. As a result, it codes the total available user memory size as 2ⁿ. If the least significant bit is 0b, the user memory size is exactly 2ⁿ. If the least significant bit is 1b, the user memory size is between 2ⁿ and 2ⁿ⁺¹.

The user memory for the MF0UL11 is 48 bytes. This memory size is between 32d bytes and 64d bytes. Therefore, the most significant 7 bits of the value 0Bh, are interpreted as 5d and the least significant bit is 1b.

The user memory for the MF0UL21 is 128 bytes. This memory size is exactly 128d. Therefore, the most significant 7 bits of the value 0Eh, are interpreted as 7d and the least significant bit is 0b.

10.2 READ

The READ command requires a start page address, and returns the 16 bytes of four MIFARE Ultralight pages. For example if address (Addr) is 03h then pages 03h, 04h, 05h, 06h are returned. A rollover mechanism is implemented if the READ command address is near the end of the accessible memory area. This rollover mechanism is also used when at least part of the addressed pages is within a password protected area. For details on those cases see the description below. The command structure is shown in [Figure 13](#) and [Table 16](#).

[Table 17](#) shows the required timing.

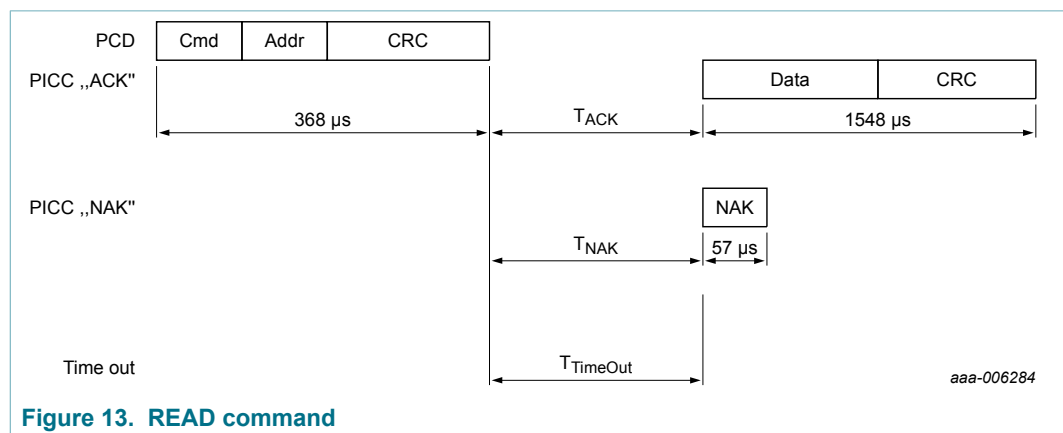

Figure 13. READ command

Table 16. READ command

Name	Code	Description	Length
Cmd	30h	read four pages	1 byte
Addr	-	start page address	1 byte
CRC	-	CRC according to Ref. 1	2 bytes
Data	-	Data content of the addressed pages	16 bytes
NAK	see Table 10	see Section 9.3	4-bit

Table 17. READ timing

These times exclude the end of communication of the PCD.

	T _{ACK min}	T _{ACK max}	T _{NAK min}	T _{NAK max}	T _{TimeOut}
READ	n=9	T _{TimeOut}	n=9	T _{TimeOut}	5 ms

In the initial state of the MF0ULx1, all memory pages are allowed as Addr parameter to the READ command.

- page address 00h to 13h for the MF0UL11
- page address 00h to 28h for the MF0UL21

Addressing a memory page beyond the limits above results in a NAK response from the MF0ULx1.

A roll-over mechanism is implemented to continue reading from page 00h once the end of the accessible memory is reached. For example, reading from address 11h on a MF0UL11 results in pages 11h, 12h, 13h and 00h being returned.

The following conditions apply if part of the memory is password protected for read access:

- if the MF0ULx1 is in the ACTIVE state
 - addressing a page which is equal or higher than AUTH0 results in a NAK response
 - addressing a page lower than AUTH0 results in data being returned with the roll-over mechanism occurring just before the AUTH0 defined page
- if the MF0ULx1 is in the AUTHENTICATED state
 - the READ command behaves like on a MF0ULx1 without access protection

Remark: PWD and PACK values can never be read out of the memory. When reading from the pages holding those two values, all 00h bytes are replied to the PCD instead.

10.3 FAST_READ

The FAST_READ command requires a start page address and an end page address and returns the all n*4 bytes of the addressed pages. For example if the start address is 03h and the end address is 07h then pages 03h, 04h, 05h, 06h and 07h are returned. If the addressed page is outside of accessible area, the MF0ULx1 replies a NAK. For details on those cases and the command structure, refer to [Figure 14](#) and [Table 18](#).

[Table 19](#) shows the required timing.

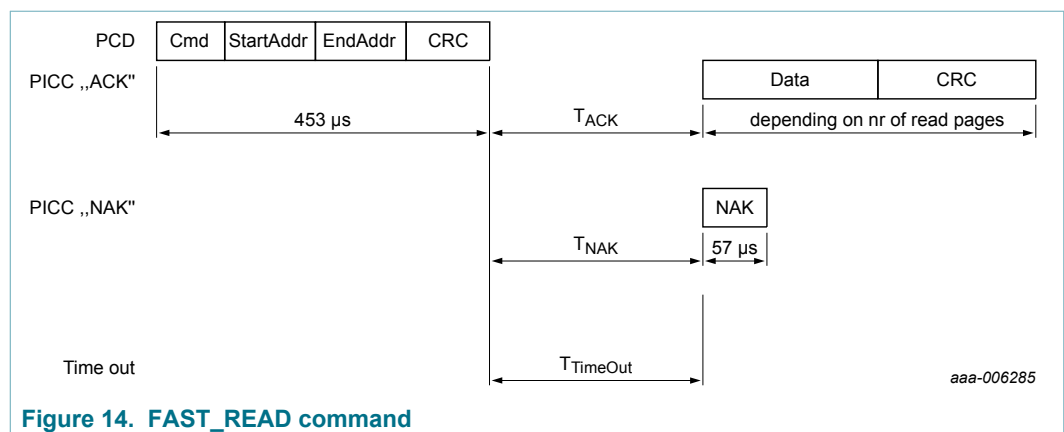

Table 18. FAST_READ command

Name	Code	Description	Length
Cmd	3Ah	read multiple pages	1 byte

Name	Code	Description	Length
StartAddr	-	start page address	1 byte
EndAddr	-	end page address	1 byte
CRC	-	CRC according to Ref. 1	2 bytes
Data	-	data content of the addressed pages	n*4 bytes
NAK	see Table 10	see Section 9.3	4-bit

Table 19. FAST_READ timing

These times exclude the end of communication of the PCD.

	T _{ACK min}	T _{ACK max}	T _{NAK min}	T _{NAK max}	T _{TimeOut}
FAST_READ	n=9	T _{TimeOut}	n=9	T _{TimeOut}	5 ms

In the initial state of the MF0ULx1, all memory pages are allowed as StartAddr parameter to the FAST_READ command.

- page address 00h to 13h for the MF0UL11
- page address 00h to 28h for the MF0UL21

Addressing a memory page beyond the limits above results in a NAK response from the MF0ULx1.

The EndAddr parameter must be equal to or higher than the StartAddr.

The following conditions apply if part of the memory is password protected for read access:

- if the MF0ULx1 is in the ACTIVE state
 - if any requested page address is equal or higher than AUTH0 a NAK is replied
- if the MF0ULx1 is in the AUTHENTICATED state
 - the FAST_READ command behaves like on a MF0ULx1 without access protection

Remark: PWD and PACK values can never be read out of the memory. When reading from the pages holding those two values, all 00h bytes are replied to the PCD instead.

Remark: The FAST_READ command is able to read out the whole memory with one command. Nevertheless, receive buffer of the PCD must be able to handle the requested amount of data as there is no chaining possibility.

10.4 WRITE

The WRITE command requires a block address, and writes 4 bytes of data into the addressed MIFARE Ultralight EV1 page. The WRITE command is shown in [Figure 15](#) and [Table 20](#).

[Table 21](#) shows the required timing.

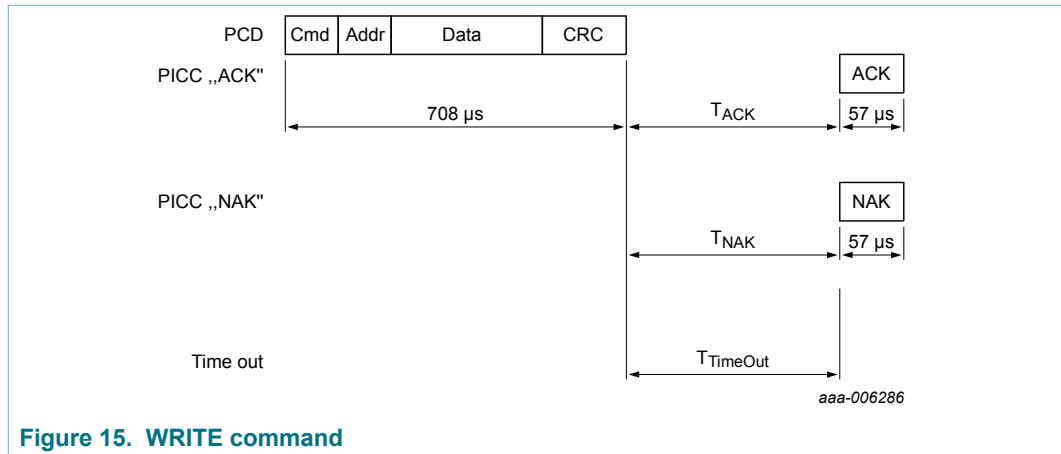

Figure 15. WRITE command

Table 20. WRITE command

Name	Code	Description	Length
Cmd	A2h	write one page	1 byte
Addr	-	page address	1 byte
CRC	-	CRC according to Ref. 1	2 bytes
Data	-	data	4 bytes
NAK	see Table 10	see Section 9.3	4-bit

Table 21. WRITE timing

These times exclude the end of communication of the PCD.

	T _{ACK min}	T _{ACK max}	T _{NAK min}	T _{NAK max}	T _{TimeOut}
WRITE	n=9	T _{TimeOut}	n=9	T _{TimeOut}	5 ms

In the initial state of the MF0ULx1, the following memory pages are valid Addr parameters to the WRITE command.

- page address 02h to 13h for the MF0UL11
- page address 02h to 28h for the MF0UL21

Addressing a memory page beyond the limits above results in a NAK response from the MF0ULx1.

Pages which are locked against writing cannot be reprogrammed using any write command. The locking mechanisms include lock bits as well as the locking of the configuration pages.

The following conditions apply if part of the memory is password protected for write access:

- if the MF0ULx1 is in the ACTIVE state
 - writing to a page which address is equal or higher than AUTH0 results in a NAK response
- if the MF0ULx1 is in the AUTHENTICATED state
 - the WRITE command behaves like on a MF0ULx1 without access protection

The MF0ULx1 features tearing protected write operations to specific memory content. The following pages are protected against tearing events during a WRITE operation:

- page 2 containing lock bits
- page 3 containing OTP bits
- page 36d containing the additional lock bits for the MF0UL21

10.5 COMPATIBILITY_WRITE

The COMPATIBILITY_WRITE command is implemented to accommodate the established MIFARE Classic PCD infrastructure. Even though 16 bytes are transferred to the MF0ULx1, only the least significant 4 bytes (bytes 0 to 3) are written to the specified address. Set all the remaining bytes, 04h to 0Fh, to logic 00h. The COMPATIBILITY_WRITE command is shown in [Figure 16](#) and [Table 20](#).

[Table 23](#) shows the required timing.

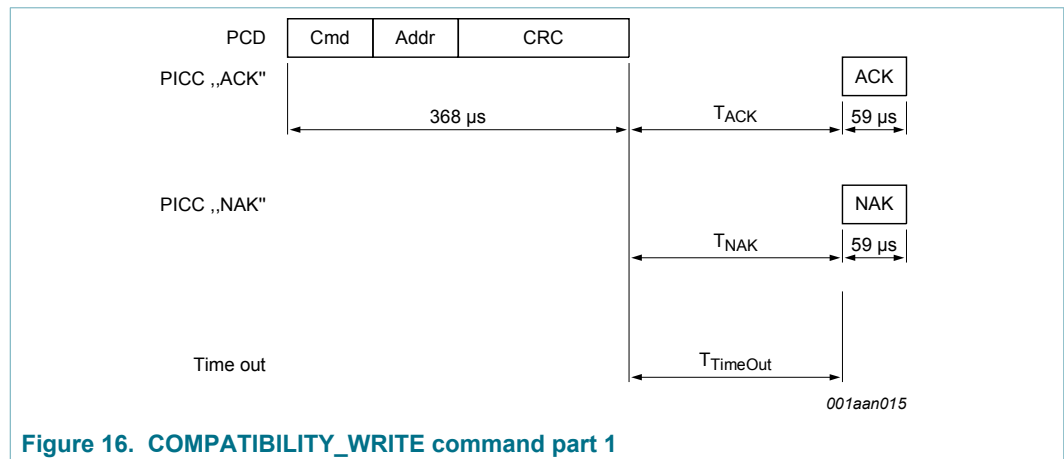

Figure 16. COMPATIBILITY_WRITE command part 1

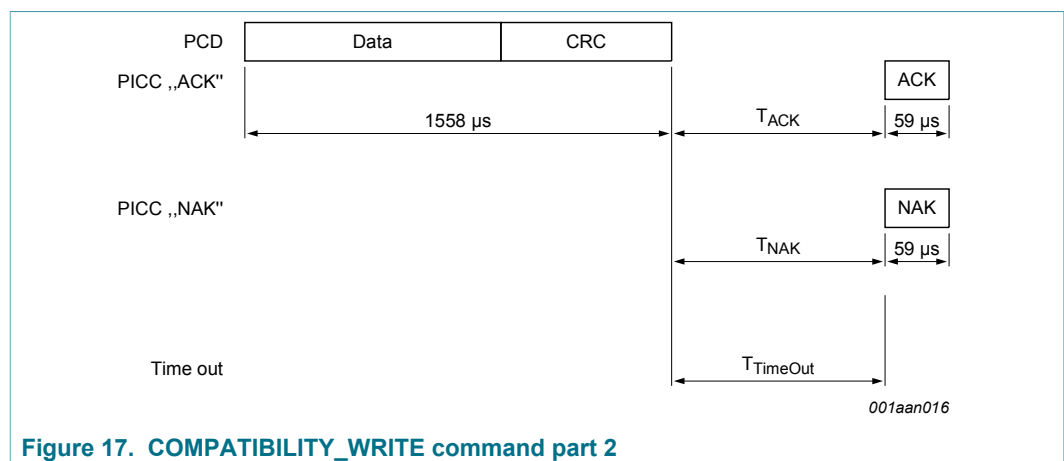

Figure 17. COMPATIBILITY_WRITE command part 2

Table 22. COMPATIBILITY_WRITE command

Name	Code	Description	Length
Cmd	A0h	compatibility write	1 byte

Name	Code	Description	Length
Addr	-	page address	1 byte
CRC	-	CRC according to Ref. 1	2 bytes
Data	-	16-byte Data, only least significant 4 bytes are written	16 bytes
NAK	see Table 10	see Section 9.3	4-bit

Table 23. COMPATIBILITY_WRITE timing

These times exclude the end of communication of the PCD.

	T _{ACK min}	T _{ACK max}	T _{NAK min}	T _{NAK max}	T _{TimeOut}
COMPATIBILITY_WRITE part 1	n=9	T _{TimeOut}	n=9	T _{TimeOut}	5 ms
COMPATIBILITY_WRITE part 2	n=9	T _{TimeOut}	n=9	T _{TimeOut}	10 ms

In the initial state of the MF0ULx1, the following memory pages are valid Addr parameters to the COMPATIBILITY_WRITE command.

- page address 02h to 13h for the MF0UL11
- page address 02h to 28h for the MF0UL21

Addressing a memory page beyond the limits above results in a NAK response from the MF0ULx1.

Pages which are locked against writing cannot be reprogrammed using any write command. The locking mechanisms include lock bits as well as the locking of the configuration pages.

The following conditions apply if part of the memory is password protected for write access:

- if the MF0ULx1 is in the ACTIVE state
 - writing to a page which address is equal or higher than AUTH0 results in a NAK response
- if the MF0ULx1 is in the AUTHENTICATED state
 - the COMPATIBILITY_WRITE command behaves the same as on a MF0ULx1 without access protection

The MF0ULx1 features tearing protected write operations to specific memory content. The following pages are protected against tearing events during a COMPATIBILITY_WRITE operation:

- page 2 containing lock bits
- page 3 containing OTP bits
- page 36d containing the additional lock bits for the MF0UL21

10.6 READ_CNT

The READ_CNT command is used to read out the current value of one of the 3 one-way counters of the MF0ULx1. The command has a single argument specifying the counter number and returns the 24-bit counter value of the corresponding counter. The counters are always readable, independent on the password protection settings. The command structure is shown in [Figure 18](#) and [Table 24](#).

Table 25 shows the required timing.

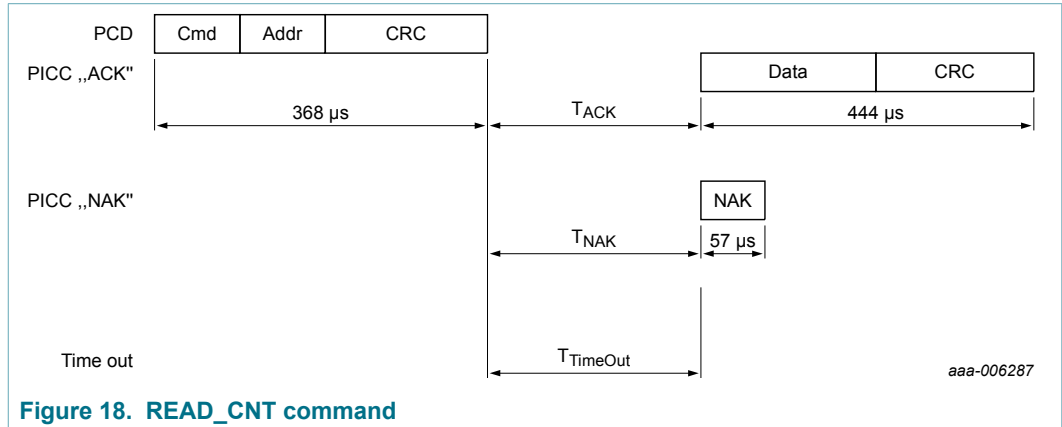

Table 24. READ_CNT command

Name	Code	Description	Length
Cmd	39h	read counter	1 byte
Addr	-	counter number from 00h to 02h	1 byte
CRC	-	CRC according to Ref. 1	2 bytes
Data	-	counter value	3 bytes
NAK	see Table 10	see Section 9.3	4-bit

Table 25. READ_CNT timing

These times exclude the end of communication of the PCD.

	T _{ACK min}	T _{ACK max}	T _{NAK min}	T _{NAK max}	T _{TimeOut}
READ_CNT	n=9	T _{TimeOut}	n=9	T _{TimeOut}	5 ms

10.7 INCR_CNT

The INCR_CNT command is used to increment one of the 3 one-way counters of the MF0ULx1. The two arguments are the counter number and the increment value. The INCR_CNT command is shown in Figure 19 and Table 26.

Table 27 shows the required timing.

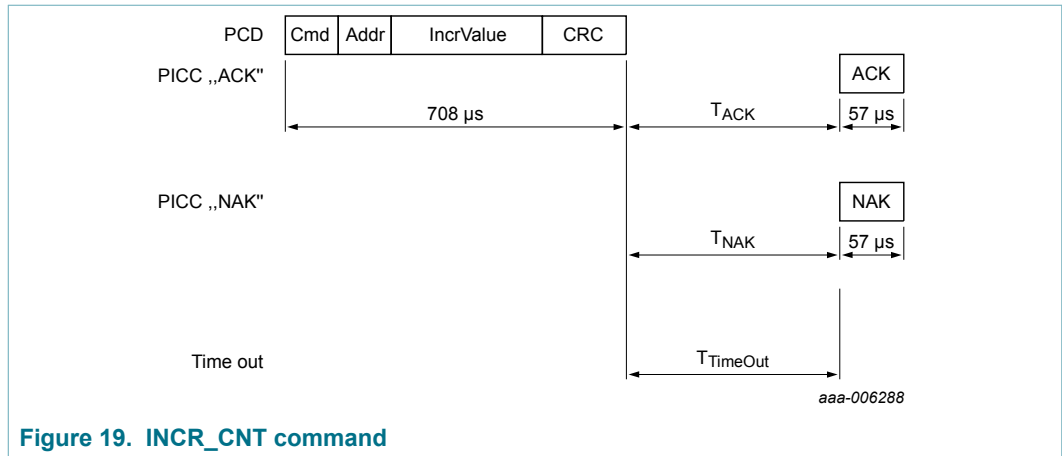

Figure 19. INCR_CNT command

Table 26. INCR_CNT command

Name	Code	Description	Length
Cmd	A5h	increment counter	1 byte
Addr	-	counter number from 00h to 02h	1 byte
IncrValue	-	increment value, only the 3 least significant bytes are relevant	4 byte
CRC	-	CRC according to Ref. 1	2 bytes
NAK	see Table 10	see Section 9.3	4-bit

Table 27. INCR_CNT timing

These times exclude the end of communication of the PCD.

	T _{ACK min}	T _{ACK max}	T _{NAK min}	T _{NAK max}	T _{TimeOut}
INCR_CNT	n=9	T _{TimeOut}	n=9	T _{TimeOut}	5 ms

The IncrValue argument is a 4-byte field to support the same command structure as the WRITE command. As the counter width is only 3 byte, the last transmitted, most significant byte is ignored.

Any increment value is allowed. Nevertheless, the final counter value is FFFFFFFh. No further increment is possible after the final value is reached. Also, trying to increment the current value by a number which would exceed the final value leads to a NAK response and the counter remains unchanged. An increment by 0 is allowed but leaves the counter unchanged.

The order of bytes in the increment argument follows the same order that the bytes are sent via the communication interface. This means from the LSbyte (IncrValue0) to MSbyte (IncrValue3), where the last valid byte is actually IncrValue2. It is in line with the arguments consisting of multiple bytes for other commands. As an example, an increment of the counter 00h by 01h, is formulated as INCR CNT 00 01 00 00 00.

The INCR_CNT command features anti-tearing support.

10.8 PWD_AUTH

A protected memory area can be accessed only after a successful password verification using the PWD_AUTH command. The AUTH0 configuration byte defines the protected area. It specifies the first page that the password mechanism protects. The level of protection can be configured using the PROT bit either for write protection or read/write protection. The PWD_AUTH command takes the password as parameter and, if successful, returns the password authentication acknowledge, PACK. By setting the AUTHLIM configuration bits to a value larger than 000b, the number of unsuccessful password verifications can be limited. Each unsuccessful authentication is then counted in a counter featuring anti-tearing support. After reaching the limit of unsuccessful attempts, the memory access specified in PROT, is no longer possible. The PWD_AUTH command is shown in Figure 20 and Table 28.

Table 29 shows the required timing.

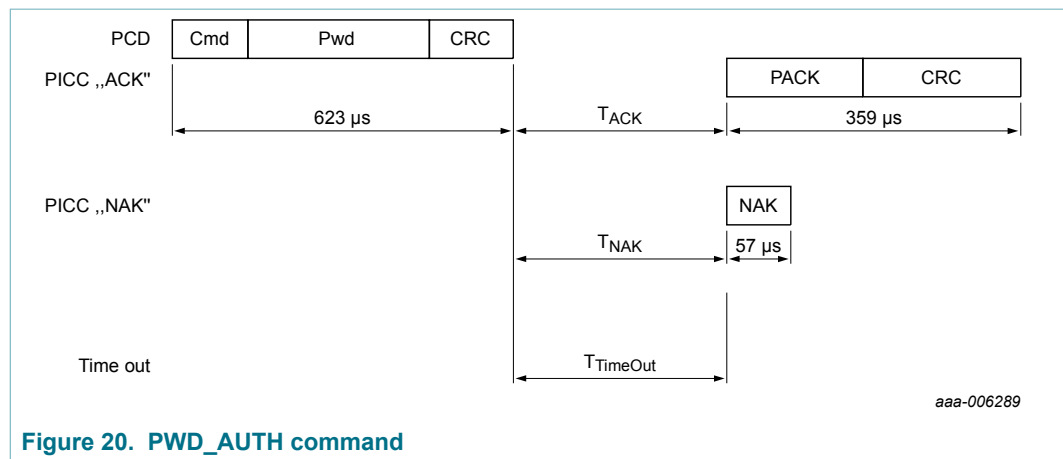

Figure 20. PWD_AUTH command

Table 28. PWD_AUTH command

Name	Code	Description	Length
Cmd	1Bh	password authentication	1 byte
Pwd	-	password	4 bytes
CRC	-	CRC according to Ref. 1	2 bytes
PACK	-	password authentication acknowledge	2 bytes
NAK	see Table 10	see Section 9.3	4-bit

Table 29. PWD_AUTH timing

These times exclude the end of communication of the PCD.

	T _{ACK min}	T _{ACK max}	T _{NAK min}	T _{NAK max}	T _{TimeOut}
PWD_AUTH	n=9	T _{TimeOut}	n=9	T _{TimeOut}	5 ms

Remark: It is strongly recommended to change the password from its delivery state at ticket issuing and set the AUTH0 value to the PWD page.

10.9 READ_SIG

The READ_SIG command returns an IC-specific, 32-byte ECC signature, to verify NXP Semiconductors as the silicon vendor. The signature is programmed at chip production and cannot be changed afterwards. The command structure is shown in [Figure 21](#) and [Table 30](#).

[Table 31](#) shows the required timing.

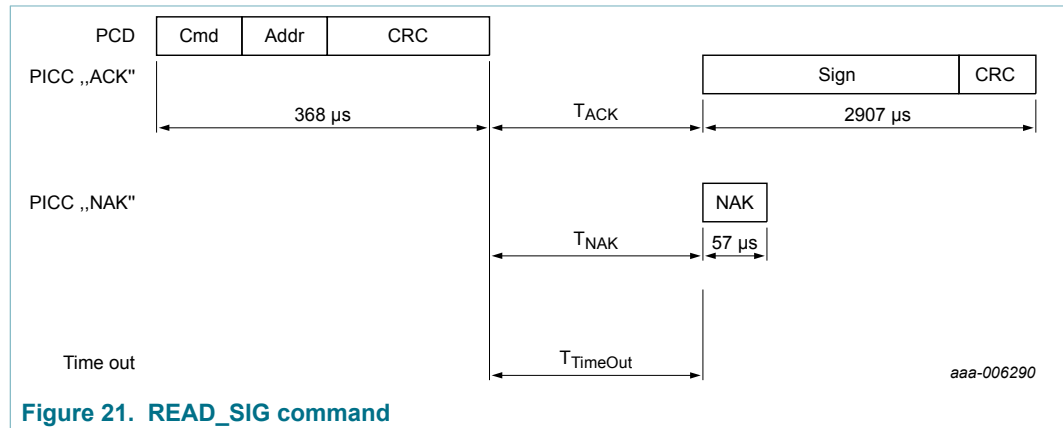

Table 30. READ_SIG command

Name	Code	Description	Length
Cmd	3Ch	read ECC signature	1 byte
Addr	00h	RFU, is set to 00h	1 byte
CRC	-	CRC according to Ref. 1	2 bytes
Sign	-	ECC signature	32 bytes
NAK	see Table 10	see Section 9.3	4-bit

Table 31. READ_SIG timing

These times exclude the end of communication of the PCD.

	$T_{ACK\ min}$	$T_{ACK\ max}$	$T_{NAK\ min}$	$T_{NAK\ max}$	$T_{TimeOut}$
READ_SIG	n=9	$T_{TimeOut}$	n=9	$T_{TimeOut}$	5 ms

[Ref. 7](#) describes the signature verification procedure.

10.10 CHECK_TEARING_EVENT

The CHECK_TEARING_EVENT command enables the application to identify if a tearing event happened on a specified counter element. It takes the counter number as single argument and returns a specified valid flag for this counter. If the returned valid flag is not equal to the predefined value, a tearing event happened. Note, although a tearing event might have happened on the counter, a valid value corresponding to the last valid counter status is still available using the READ_CNT command. The command structure is shown in [Figure 22](#) and [Table 32](#).

Table 33 shows the required timing.

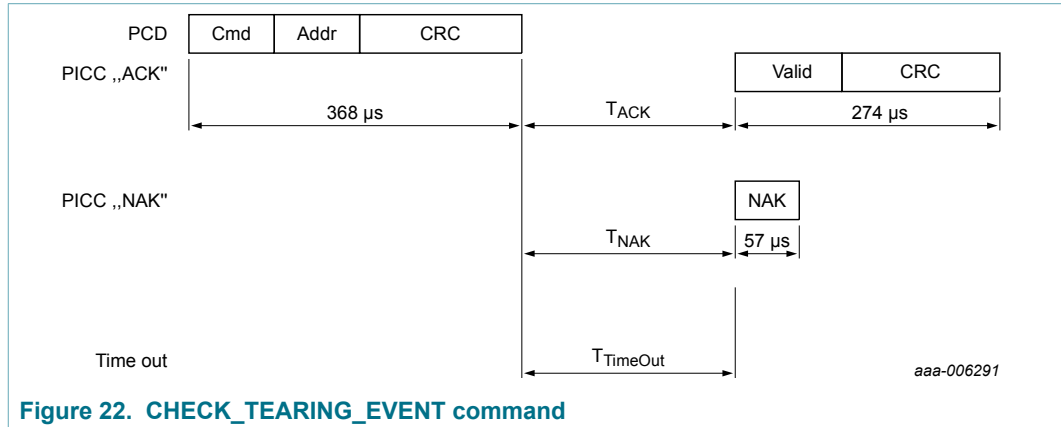

Figure 22. CHECK_TEARING_EVENT command

Table 32. CHECK_TEARING_EVENT command

Name	Code	Description	Length
Cmd	3Eh	check tearing event	1 byte
Addr	-	counter number from 00h to 02h	1 byte
CRC	-	CRC according to Ref. 1	2 bytes
Valid	-	valid flag	1 byte
NAK	see Table 10	see Section 9.3	4-bit

Table 33. CHECK_TEARING_EVENT timing

These times exclude the end of communication of the PCD.

	T _{ACK min}	T _{ACK max}	T _{NAK min}	T _{NAK max}	T _{TimeOut}
CHECK_TEARING_EVENT	n=9	T _{TimeOut}	n=9	T _{TimeOut}	5 ms

The valid flag for normal operation is BDh. If any other value than BDh is replied on the CHECK_TEARING_EVENT command, a tearing event has happened on the addressed counter.

The application can use this information to base business logic decisions on.

10.11 VCSL

The VCSL command is used to enable a unique identification and selection process across different MIFARE product-based cards and card implementations on mobile devices. The command requires a 16-byte installation identifier IID and a 4-byte PCD capability value as parameters. The parameters are present to support compatibility to other MIFARE product-based devices but are not used or checked inside the MF0ULx1. Nevertheless, the number of bytes is checked for correctness. The answer to the VCSL command is the virtual card type identifier VCTID. This identifier indicates the type of card or ticket. Using this information, the reader can decide whether the ticket belongs to the installation or not. The command structure is shown in Figure 23 and Table 34.

Table 35 shows the required timing.

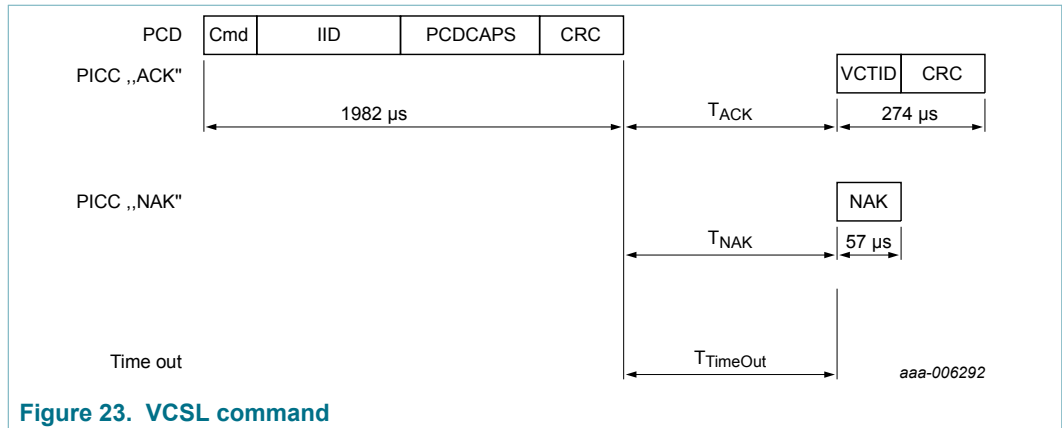

Figure 23. VCSL command

Table 34. VCSL command

Name	Code	Description	Length
Cmd	4B	read four pages	1 byte
IID	-	installation identifier	16 bytes
PCDCAPS	-	PCD capabilities	4 bytes
CRC	-	CRC according to Ref. 1	2 bytes
VCTID	-	virtual Card Type Identifier	1 byte
NAK	see Table 10	see Section 9.3	4-bit

Table 35. VCSL timing

These times exclude the end of communication of the PCD.

	T _{ACK min}	T _{ACK max}	T _{NAK min}	T _{NAK max}	T _{TimeOut}
VCSL	n=9	T _{TimeOut}	n=9	T _{TimeOut}	5 ms

11 Limiting values

Stresses exceeding one or more of the limiting values, can cause permanent damage to the device. Exposure to limiting values for extended periods can affect device reliability.

Table 36. Limiting values

In accordance with the Absolute Maximum Rating System (IEC 60134).

Symbol	Parameter	Min	Max	Unit
I _I	input current	-	40	mA
P _{tot} /pack	total power dissipation per package	-	120	mW
T _{stg}	storage temperature	-55	125	°C
T _{amb}	ambient temperature	-25	70	°C
V _{ESD}	electrostatic discharge voltage on LA/LB ^[1]	2	-	kV

[1] ANSI/ESDA/JEDEC JS-001; Human body model: C = 100 pF, R = 1.5 kΩ

CAUTION	
	<p>This device is sensitive to ElectroStatic Discharge (ESD). Observe precautions for handling electrostatic sensitive devices. Such precautions are described in the <i>ANSI/ESD S20.20</i>, <i>IEC/ST 61340-5</i>, <i>JESD625-A</i> or equivalent standards.</p>

12 Characteristics

Table 37. Characteristics

Symbol	Parameter	Conditions	Min	Typ	Max	Unit
C _i	input capacitance MF0ULx1		[1] -	17.0	-	pF
C _i	input capacitance MF0ULHx1		[1] -	50.0	-	pF
f _i	input frequency		-	13.56	-	MHz
EEPROM characteristics						
t _{ret}	retention time	T _{amb} = 22 °C	10	-	-	year
N _{endu(W)}	write endurance	T _{amb} = 22 °C	100000	-	-	cycle
N _{endu(W)}	write endurance counters	T _{amb} = 22 °C	100000	1000000	-	cycle

[1] T_{amb} = 22 °C, f = 13.56 MHz, V_{LaLb} = 1.5 V RMS

13 Wafer specification

Table 38. Wafer specifications MF0ULx1

Wafer	
diameter	200 mm typical (8 inches) 300 mm typical (12inches)
maximum diameter after foil expansion	210 mm (8 inches) not applicable (12inches)
die separation process	laser dicing (8 inches) blade dicing (12 inches)
thickness MF0ULx101DUD	120 μm ± 15 μm
MF0ULx101DUF	75 μm ± 10 μm
flatness	not applicable
Potential Good Dies per Wafer (PGDW) MF0ULx1	103682 (8 inches) 219126 (12 inches)
MF0ULHx1	86470 (8 inches)
Wafer backside	
material	Si
treatment	ground and stress relieve
roughness	R _a max = 0.5 μm
	R _t max = 5 μm
Chip dimensions	

step size ^[1] MF0ULx1	x = 505 μm (8 inches) x = 505 μm (12 inches)
	y = 590 μm (8 inches) y = 590 μm (12 inches)
step size ^[1] MF0ULHx1	x = 505 μm
	y = 720 μm
gap between chips ^[1]	typical = 20 μm
	minimum = 5 μm not applicable (12 inches)
Passivation	
type	sandwich structure
material	PSG / nitride
thickness	500 nm / 600 nm
Au bump (substrate connected to VSS)	
material	> 99.9 % pure Au
hardness	35 to 80 HV 0.005
shear strength	> 70 MPa
height	18 μm
height uniformity	within a die = $\pm 2 \mu\text{m}$
	within a wafer = $\pm 3 \mu\text{m}$
	wafer to wafer = $\pm 4 \mu\text{m}$
flatness	minimum = $\pm 1.5 \mu\text{m}$
size	LA, LB, GND, TP ^[2] = 60 μm \times 60 μm
size variation	$\pm 5 \mu\text{m}$
under bump metallization	sputtered TiW

[1] The step size and the gap between chips may vary due to changing foil expansion

[2] Pads GND and TP are disconnected when wafer is sawn

13.1 Fail die identification

Electronic wafer mapping covers the electrical test results and the results of mechanical/visual inspection. No ink dots are applied.

14 Package outline

For more details on the contactless MOA8 module, refer to [Ref. 5](#).

PLLMC: plastic leadless module carrier package; 35 mm wide tape

SOT500-4

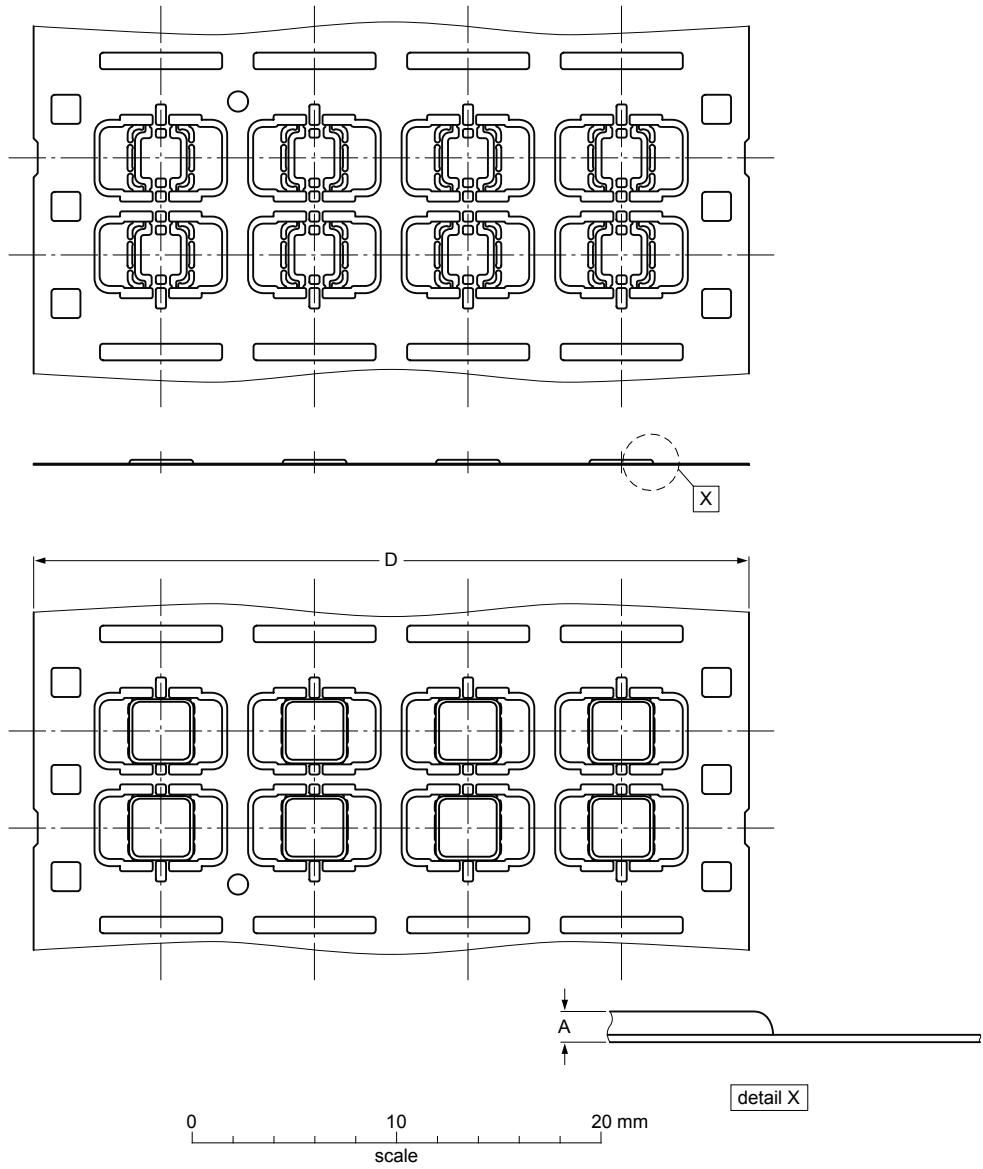

Dimensions

Unit	A ⁽¹⁾	D	
mm	max 0.26	35.05	For unspecified dimensions see PLLMC-drawing given in the subpackage code.
	nom 35.00		
	min 34.95		

Note

1. Total package thickness, exclusive punching burr.

sot500-4_po

Outline version	References			European projection	Issue date
	IEC	JEDEC	JEITA		
SOT500-4	---	---	---		11-02-18

Figure 24. Package outline SOT500-4

15 Bare die outline

For more details on the wafer delivery forms, see [Ref. 6](#).

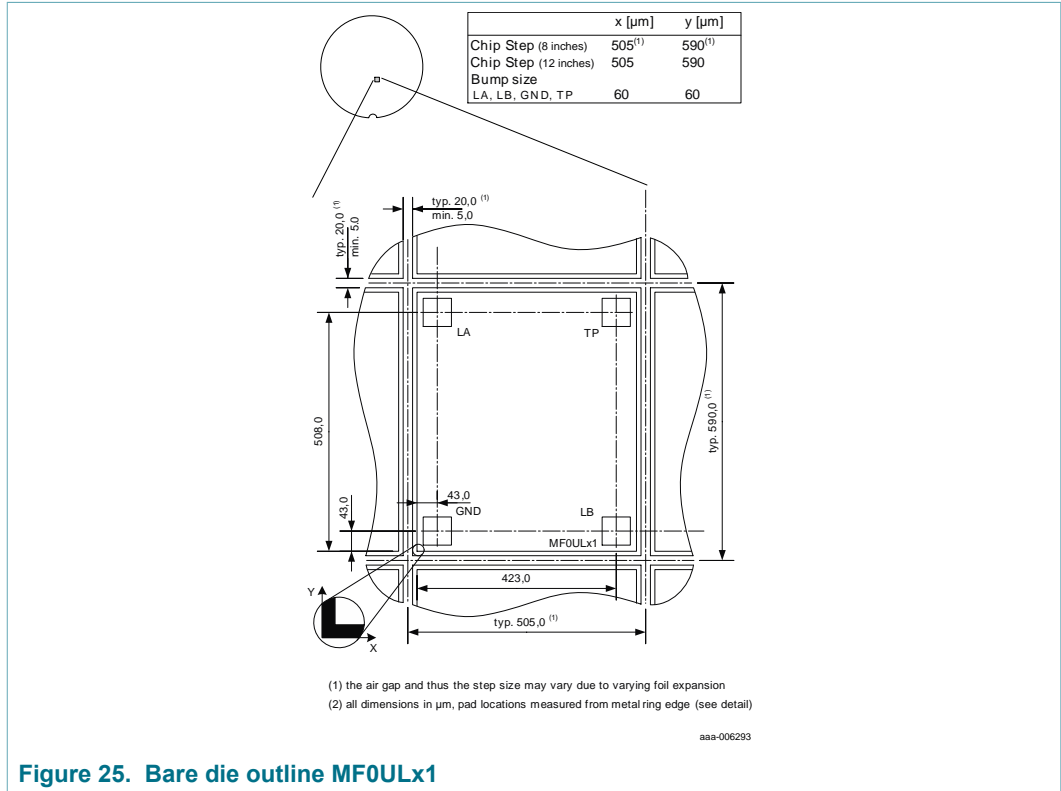
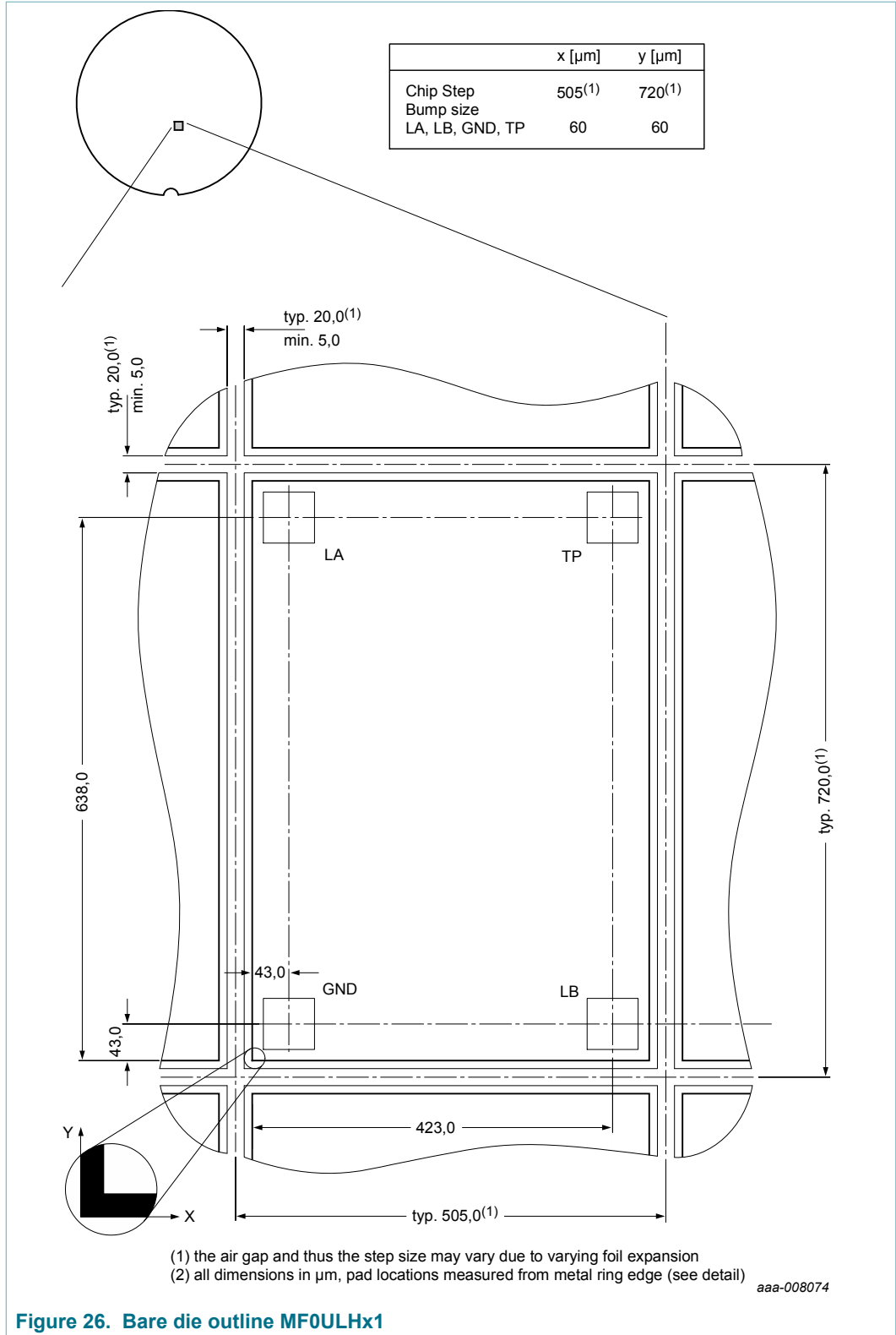

Figure 25. Bare die outline MF0ULx1



16 Abbreviations

Table 39. Abbreviations and symbols

Acronym	Description
ACK	Acknowledge
ATQA	Answer to request: Type A
CRC	Cyclic Redundancy Check
CT	Cascade Tag (value 88h) as defined in ISO/IEC 14443-3 Type A
ECC	Elliptic Curve Cryptography
EEPROM	Electrically Erasable Programmable Read-Only Memory
FDT	Frame Delay Time
FFC	Film Frame Carrier
IC	Integrated Circuit
IID	Installation Identifier
LCR	L = inductance, Capacitance, Resistance (LCR meter)
LSB	Least Significant Bit
LSByte	Least Significant Byte
MSByte	Most Significant Byte
NAK	Not acknowledge
NV	Non-Volatile memory
OTP	One Time Programmable
PCD	Proximity Coupling Device (contactless reader)
PCDCAPS	PCD Capability bytes
PICC	Proximity Integrated Circuit Card (contactless card)
REQA	Request command: Type A
RF	Radio Frequency
RFUI	Reserver for Future Use - Implemented
RMS	Root Mean Square
SAK	Select acknowledge: Type A
SECS-II	SEMI Equipment Communications Standard part 2
TiW	Titanium Tungsten
UID	Unique identifier
VCTID	Virtual Card Type Identifier
WUPA	Wake-Up Protocol: Type A

17 References

[1]

ISO/IEC 14443

International Organization for Standardization

[2]

MIFARE (Card) Coil Design Guide

Application note, BU-ID Document number 0117** ¹

[3]

MIFARE Type Identification Procedure

Application note, BU-ID Document number 0184**¹

[4]

MIFARE ISO/IEC 14443 PICC Selection

Application note, BU-ID Document number 1308**¹

[5]

Contactless smart card module specification MOA8

Delivery Type Description, BU-ID Document number 1636**¹

[6]

General specification for 8" wafer on UV-tape; delivery types

Delivery Type Description, BU-ID Document number 1005**¹

[7]

AN073121 MIFARE Ultralight Features and Hints

Application note, BU-ID Document number 0731**

[8]

ISO/IEC 15457-1 Identification cards

Thin flexible cards

¹ ** ... document version number

18 Revision history

Table 40. Revision history

Document ID	Release date	Data sheet status	Change notice	Supersedes
MF0ULx1 v.3.3	20180409	Product data sheet	-	MF0ULx1 v.3.2
Modifications:	<ul style="list-style-type: none"> • Editorial updates 			
MF0ULx1 v.3.2	20171127	Product data sheet	-	MF0ULx1 v.3.1
Modifications:	<ul style="list-style-type: none"> • 12 inch FFC delivery forms added 			
MF0ULx1 v.3.1	20130724	Product data sheet	-	MF0ULx1 v.3.0
Modifications:	<ul style="list-style-type: none"> • Editorial changes • Added 50 pF delivery types 			
MF0ULx1 v.3.0	20130219	Product data sheet	-	234521
Modifications:	<ul style="list-style-type: none"> • Editorial changes • Security status changed into "COMPANY PUBLIC" • Added default values for configuration elements in Table 8 • Corrected response timing in Figure 18 • Corrected PCDCAPS length in Table 34 • Changed EEPROM reliability parameters for counters 			
234521	20120928	Preliminary data sheet	-	234520
Modifications:	<ul style="list-style-type: none"> • Editorial changes • Changed EEPROM reliability parameters 			
234520	20120525	Objective data sheet	-	-
	<ul style="list-style-type: none"> • Initial version 			

19 Legal information

19.1 Data sheet status

Document status ^{[1][2]}	Product status ^[3]	Definition
Objective [short] data sheet	Development	This document contains data from the objective specification for product development.
Preliminary [short] data sheet	Qualification	This document contains data from the preliminary specification.
Product [short] data sheet	Production	This document contains the product specification.

[1] Please consult the most recently issued document before initiating or completing a design.

[2] The term 'short data sheet' is explained in section "Definitions".

[3] The product status of device(s) described in this document may have changed since this document was published and may differ in case of multiple devices. The latest product status information is available on the Internet at URL <http://www.nxp.com>.

19.2 Definitions

Draft — The document is a draft version only. The content is still under internal review and subject to formal approval, which may result in modifications or additions. NXP Semiconductors does not give any representations or warranties as to the accuracy or completeness of information included herein and shall have no liability for the consequences of use of such information.

Short data sheet — A short data sheet is an extract from a full data sheet with the same product type number(s) and title. A short data sheet is intended for quick reference only and should not be relied upon to contain detailed and full information. For detailed and full information see the relevant full data sheet, which is available on request via the local NXP Semiconductors sales office. In case of any inconsistency or conflict with the short data sheet, the full data sheet shall prevail.

Product specification — The information and data provided in a Product data sheet shall define the specification of the product as agreed between NXP Semiconductors and its customer, unless NXP Semiconductors and customer have explicitly agreed otherwise in writing. In no event however, shall an agreement be valid in which the NXP Semiconductors product is deemed to offer functions and qualities beyond those described in the Product data sheet.

19.3 Disclaimers

Limited warranty and liability — Information in this document is believed to be accurate and reliable. However, NXP Semiconductors does not give any representations or warranties, expressed or implied, as to the accuracy or completeness of such information and shall have no liability for the consequences of use of such information. NXP Semiconductors takes no responsibility for the content in this document if provided by an information source outside of NXP Semiconductors. In no event shall NXP Semiconductors be liable for any indirect, incidental, punitive, special or consequential damages (including - without limitation - lost profits, lost savings, business interruption, costs related to the removal or replacement of any products or rework charges) whether or not such damages are based on tort (including negligence), warranty, breach of contract or any other legal theory. Notwithstanding any damages that customer might incur for any reason whatsoever, NXP Semiconductors' aggregate and cumulative liability towards customer for the products described herein shall be limited in accordance with the Terms and conditions of commercial sale of NXP Semiconductors.

Right to make changes — NXP Semiconductors reserves the right to make changes to information published in this document, including without limitation specifications and product descriptions, at any time and without

notice. This document supersedes and replaces all information supplied prior to the publication hereof.

Suitability for use — NXP Semiconductors products are not designed, authorized or warranted to be suitable for use in life support, life-critical or safety-critical systems or equipment, nor in applications where failure or malfunction of an NXP Semiconductors product can reasonably be expected to result in personal injury, death or severe property or environmental damage. NXP Semiconductors and its suppliers accept no liability for inclusion and/or use of NXP Semiconductors products in such equipment or applications and therefore such inclusion and/or use is at the customer's own risk.

Applications — Applications that are described herein for any of these products are for illustrative purposes only. NXP Semiconductors makes no representation or warranty that such applications will be suitable for the specified use without further testing or modification. Customers are responsible for the design and operation of their applications and products using NXP Semiconductors products, and NXP Semiconductors accepts no liability for any assistance with applications or customer product design. It is customer's sole responsibility to determine whether the NXP Semiconductors product is suitable and fit for the customer's applications and products planned, as well as for the planned application and use of customer's third party customer(s). Customers should provide appropriate design and operating safeguards to minimize the risks associated with their applications and products. NXP Semiconductors does not accept any liability related to any default, damage, costs or problem which is based on any weakness or default in the customer's applications or products, or the application or use by customer's third party customer(s). Customer is responsible for doing all necessary testing for the customer's applications and products using NXP Semiconductors products in order to avoid a default of the applications and the products or of the application or use by customer's third party customer(s). NXP does not accept any liability in this respect.

Limiting values — Stress above one or more limiting values (as defined in the Absolute Maximum Ratings System of IEC 60134) will cause permanent damage to the device. Limiting values are stress ratings only and (proper) operation of the device at these or any other conditions above those given in the Recommended operating conditions section (if present) or the Characteristics sections of this document is not warranted. Constant or repeated exposure to limiting values will permanently and irreversibly affect the quality and reliability of the device.

Terms and conditions of commercial sale — NXP Semiconductors products are sold subject to the general terms and conditions of commercial sale, as published at <http://www.nxp.com/profile/terms>, unless otherwise agreed in a valid written individual agreement. In case an individual agreement is concluded only the terms and conditions of the respective agreement shall apply. NXP Semiconductors hereby expressly objects to applying the customer's general terms and conditions with regard to the purchase of NXP Semiconductors products by customer.

No offer to sell or license — Nothing in this document may be interpreted or construed as an offer to sell products that is open for acceptance or the grant, conveyance or implication of any license under any copyrights, patents or other industrial or intellectual property rights.

Quick reference data — The Quick reference data is an extract of the product data given in the Limiting values and Characteristics sections of this document, and as such is not complete, exhaustive or legally binding.

Export control — This document as well as the item(s) described herein may be subject to export control regulations. Export might require a prior authorization from competent authorities.

Non-automotive qualified products — Unless this data sheet expressly states that this specific NXP Semiconductors product is automotive qualified, the product is not suitable for automotive use. It is neither qualified nor tested in accordance with automotive testing or application requirements. NXP Semiconductors accepts no liability for inclusion and/or use of non-automotive qualified products in automotive equipment or applications. In the event that customer uses the product for design-in and use in automotive applications to automotive specifications and standards, customer (a) shall use the product without NXP Semiconductors' warranty of the product for such automotive applications, use and specifications, and (b) whenever

customer uses the product for automotive applications beyond NXP Semiconductors' specifications such use shall be solely at customer's own risk, and (c) customer fully indemnifies NXP Semiconductors for any liability, damages or failed product claims resulting from customer design and use of the product for automotive applications beyond NXP Semiconductors' standard warranty and NXP Semiconductors' product specifications.

Translations — A non-English (translated) version of a document is for reference only. The English version shall prevail in case of any discrepancy between the translated and English versions.

19.4 Trademarks

Notice: All referenced brands, product names, service names and trademarks are the property of their respective owners.

MIFARE — is a trademark of NXP B.V.

DESFire — is a trademark of NXP B.V.

MIFARE Plus — is a trademark of NXP B.V.

MIFARE Ultralight — is a trademark of NXP B.V.

Tables

Tab. 1.	Naming conventions	2	Tab. 21.	WRITE timing	25
Tab. 2.	Quick reference data	3	Tab. 22.	COMPATIBILITY_WRITE command	26
Tab. 3.	Ordering information	4	Tab. 23.	COMPATIBILITY_WRITE timing	27
Tab. 4.	Pin allocation table	5	Tab. 24.	READ_CNT command	28
Tab. 5.	Configuration Pages	14	Tab. 25.	READ_CNT timing	28
Tab. 6.	MOD configuration byte	15	Tab. 26.	INCR_CNT command	29
Tab. 7.	ACCESS configuration byte	15	Tab. 27.	INCR_CNT timing	29
Tab. 8.	Configuration parameter descriptions	15	Tab. 28.	PWD_AUTH command	30
Tab. 9.	Command overview	18	Tab. 29.	PWD_AUTH timing	30
Tab. 10.	ACK and NAK values	19	Tab. 30.	READ_SIG command	31
Tab. 11.	ATQA response of the MF0ULx1	20	Tab. 31.	READ_SIG timing	31
Tab. 12.	SAK response of the MF0ULx1	20	Tab. 32.	CHECK_TEARING_EVENT command	32
Tab. 13.	GET_VERSION command	21	Tab. 33.	CHECK_TEARING_EVENT timing	32
Tab. 14.	GET_VERSION timing	21	Tab. 34.	VCSL command	33
Tab. 15.	GET_VERSION response for MF0UL11 and MF0UL21	21	Tab. 35.	VCSL timing	33
Tab. 16.	READ command	22	Tab. 36.	Limiting values	33
Tab. 17.	READ timing	22	Tab. 37.	Characteristics	34
Tab. 18.	FAST_READ command	23	Tab. 38.	Wafer specifications MF0ULx1	34
Tab. 19.	FAST_READ timing	24	Tab. 39.	Abbreviations and symbols	39
Tab. 20.	WRITE command	25	Tab. 40.	Revision history	41

Figures

Fig. 1.	Contactless system	1	Fig. 14.	FAST_READ command	23
Fig. 2.	Block diagram of MF0ULx1	5	Fig. 15.	WRITE command	25
Fig. 3.	Pin configuration for SOT500-4 (MOA8)	5	Fig. 16.	COMPATIBILITY_WRITE command part 1	26
Fig. 4.	State diagram	8	Fig. 17.	COMPATIBILITY_WRITE command part 2	26
Fig. 5.	Memory organization MF0UL11	10	Fig. 18.	READ_CNT command	28
Fig. 6.	Memory organization MF0UL21	11	Fig. 19.	INCR_CNT command	29
Fig. 7.	UID/serial number	11	Fig. 20.	PWD_AUTH command	30
Fig. 8.	Lock bytes 0 and 1	12	Fig. 21.	READ_SIG command	31
Fig. 9.	Lock bytes 2-4	13	Fig. 22.	CHECK_TEARING_EVENT command	32
Fig. 10.	OTP bytes	14	Fig. 23.	VCSL command	33
Fig. 11.	Frame Delay Time (from PCD to PICC)	19	Fig. 24.	Package outline SOT500-4	36
Fig. 12.	GET_VERSION command	21	Fig. 25.	Bare die outline MF0ULx1	37
Fig. 13.	READ command	22	Fig. 26.	Bare die outline MF0ULHx1	38

Contents

1	General description	1	10.9	READ_SIG	31
1.1	Contactless energy and data transfer	1	10.10	CHECK_TEARING_EVENT	31
1.2	Anticollision	1	10.11	VCSL	32
1.3	Simple integration and user convenience	2	11	Limiting values	33
1.4	Security	2	12	Characteristics	34
1.5	Naming conventions	2	13	Wafer specification	34
2	Features and benefits	2	13.1	Fail die identification	35
2.1	EEPROM	3	14	Package outline	35
3	Applications	3	15	Bare die outline	37
4	Quick reference data	3	16	Abbreviations	39
5	Ordering information	4	17	References	40
6	Block diagram	5	18	Revision history	41
7	Pinning information	5	19	Legal information	42
7.1	Pinning	5			
8	Functional description	6			
8.1	Block description	6			
8.2	RF interface	6			
8.3	Data integrity	7			
8.4	Communication principle	7			
8.4.1	IDLE state	8			
8.4.2	READY1 state	9			
8.4.3	READY2 state	9			
8.4.4	ACTIVE state	9			
8.4.5	AUTHENTICATED state	9			
8.4.6	HALT state	10			
8.5	Memory organization	10			
8.5.1	UID/serial number	11			
8.5.2	Lock byte 0 and byte 1	12			
8.5.3	Lock byte 2 to byte 4	12			
8.5.4	OTP bytes	13			
8.5.5	Data pages	14			
8.5.6	Configuration pages	14			
8.6	Password verification protection	16			
8.6.1	Programming of PWD and PACK	16			
8.6.2	Limiting negative verification attempts	16			
8.6.3	Protection of special memory segments	17			
8.7	Counter functionality	17			
8.8	Originality function	17			
8.9	Virtual Card Architecture Support	17			
9	Command overview	18			
9.1	MIFARE Ultralight EV1 command overview	18			
9.2	Timing	18			
9.3	MIFARE Ultralight ACK and NAK	19			
9.4	ATQA and SAK responses	20			
10	MIFARE Ultralight EV1 commands	20			
10.1	GET_VERSION	20			
10.2	READ	22			
10.3	FAST_READ	23			
10.4	WRITE	24			
10.5	COMPATIBILITY_WRITE	26			
10.6	READ_CNT	27			
10.7	INCR_CNT	28			
10.8	PWD_AUTH	30			

Please be aware that important notices concerning this document and the product(s) described herein, have been included in section 'Legal information'.

© NXP B.V. 2019.

All rights reserved.

For more information, please visit: <http://www.nxp.com>

For sales office addresses, please send an email to: salesaddresses@nxp.com

Date of release: 9 April 2019

Document identifier: MF0ULX1

Document number: 234533