

SPECIALIZED USER MANUAL

FUTURE SHOCK FRONT SUSPENSION (2.0 damped and 1.5 undamped)



THIS BRIEF USER MANUAL CONTAINS IMPORTANT INFORMATION. PLEASE READ CAREFULLY AND STORE IN A SAFE PLACE.

This user manual is specific to your Specialized bicycle equipped with Future Shock front suspension. It contains important safety, performance and technical information, which you should read before your first ride and keep for reference. You should also read the entire Specialized Bicycle Owner's Manual ("Owner's Manual"), because it has additional important general information and instructions which you should follow. If you do not have a copy of the Owner's Manual, you can download it at no cost at www.specialized.com, or obtain it from your nearest Authorized Specialized Retailer or Specialized Rider Care.

Additional safety, performance, and service information for specific components such as suspension or pedals on your bicycle, or for accessories such as helmets or lights, may also be available. Make sure that your Authorized Specialized Retailer has given you all the manufacturers' literature that was included with your bicycle or accessories. If there is a difference between the instructions in this manual and the information provided by the component manufacturer, please refer to your Authorized Specialized Retailer.

When reading this user manual, you will note various important symbols and warnings, which are explained below:

	WARNING! The combination of this symbol and word indicates a potentially hazardous situation which, if not avoided, could result in serious injury or death. Many of the Warnings say "you may lose control and fall." Because any fall can result in serious injury or even death, we do not always repeat the warning of possible injury or death.
	CAUTION: The combination of the safety alert symbol and the word CAUTION indicates a potentially hazardous situation, which, if not avoided, may result in minor or moderate injury, or is an alert against unsafe practices. The word CAUTION used without the safety alert symbol indicates a situation which, if not avoided, could result in serious damage to the bicycle or the voiding of your warranty.
	INFO: This symbol alerts the reader to information which is particularly important.
	GREASE: This symbol means that high quality grease should be applied as illustrated.
	CARBON FRICTION PASTE: This symbol means that carbon friction paste should be applied as illustrated to increase friction.
	TORQUE: This symbol highlights the correct torque value for a specific bolt. In order to achieve the specified torque value, a quality torque wrench must be used.
	TECH TIP: Tech Tips are useful tips and tricks regarding installation and use.

INTENDED USE

The Specialized Future Shock front suspension is intended and tested for road biking (condition 1) use only. For more information on intended use and structural weight limits for the frame and components, please refer to the Owner's Manual.

GENERAL NOTES ABOUT ASSEMBLY

This manual is not intended as a comprehensive assembly, use, service, repair, or maintenance guide. Please see your Authorized Specialized Retailer for all service, repairs, or maintenance. Your Authorized Specialized Retailer may also be able to refer you to classes, clinics or books on bicycle use, service, repair, and maintenance.

	WARNING! Due to the high degree of complexity of the Future Shock, proper assembly requires a high degree of mechanical expertise, skill, training and specialty tools. Therefore, it is essential that the assembly, maintenance and troubleshooting be performed by an Authorized Specialized Retailer.
	WARNING! The Future Shock suspension and the proprietary components that work with the Future Shock are specific to Specialized bicycles equipped with the Future Shock. Only use originally supplied components and hardware at all times. Use of other components or hardware will compromise the integrity and strength of the assembly. Future Shock specific components should only be used on Specialized bicycles designed for Future Shock, even if they fit. Failure to follow this warning could result in serious injury or death.
	The Future Shock is available in damped and undamped models, depending on the bicycle. Installation is the same for both models. In order to successfully install the Future Shock, it is very important to follow the order of operations as outlined in this manual. Modifying the order of assembly will result in a longer build process.

BOLT SIZE / TOOLS / TORQUE SPECS

	WARNING! Correct tightening force on fasteners (nuts, bolts, screws) on your bicycle is important for your safety. If too little force is applied, the fastener may not hold securely. If too much force is applied, the fastener can strip threads, stretch, deform or break. Either way, incorrect tightening force can result in component failure, which can cause you to lose control and fall. Where indicated, ensure that each bolt is torqued to specification. After your first ride, and consistently thereafter, recheck the tightness of each bolt to ensure secure attachment of the components. The following is a summary of torque specifications in this manual:
--	--

LOCATION	Hex key	Torque (in-lbf)	Torque (Nm)	LOCATION	Hex key	Torque (in-lbf)	Torque (Nm)
STEM @ STEERER TUBE	4 mm	45	5.0	LOCKING SCREWS	2.5 mm	9.5	1.0
STEM @ HANDLEBAR	4 mm	45	5.0	ACCESSORY MOUNT	3 mm	24	2.7
STEERER TUBE COLLAR (side)	4 mm	35	4.0	FUTURE SHOCK KNOB (damped version only)	1.5 mm	18	2
STEERER TUBE COLLAR (front)	2.5 mm	9.5	1.0				

SPECIALIZED BICYCLE COMPONENTS

15130 Concord Circle, Morgan Hill, CA 95037 (408) 779-6229
0000134022_UM_EN_R6_06/21

We may occasionally issue updates and addendums to this document. Please periodically check www.specialized.com or contact Rider Care to make sure you have the latest information.
Info: ridercare@specialized.com / 877 808-8154

INSTALLING THE FORK AND FUTURE SHOCK CARTRIDGE

- The Specialized Future Shock cartridge and headset are designed as an integrated unit and are only intended for use with compatible frames and forks. Only use the specified parts when assembling the front end of a Future Shock equipped bicycle.

⚠ WARNING! The fork steerer tube is pre-cut to the size of the frame. Do not cut the fork or use a fork that is too short. Ensure that the size written on the fork matches the size of the frame.

- The damped 2.0 Future Shock cartridge has only been tested and approved for use on bicycles that have the damped cartridge spec'd as original equipment.
- Future Shock bicycles are equipped with a custom headset cap. Different bicycle models may have different shape caps. Be sure to use the correct option for your bicycle.

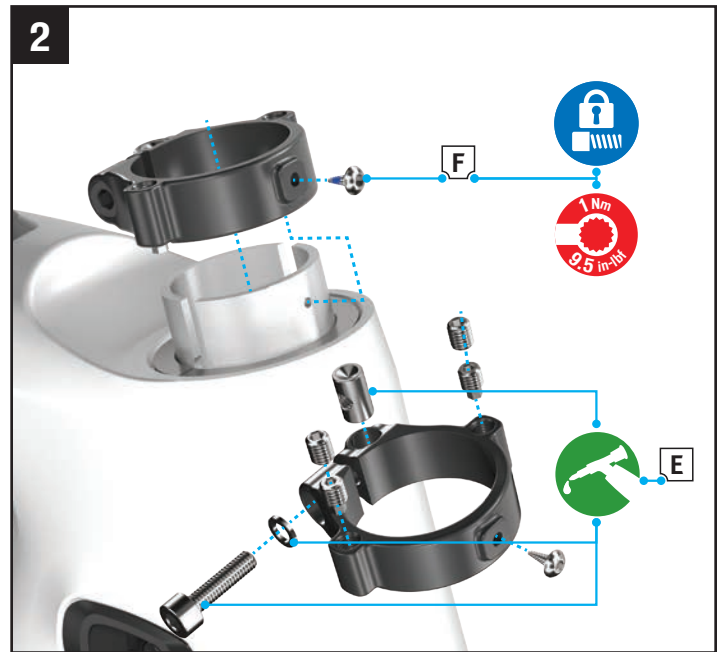
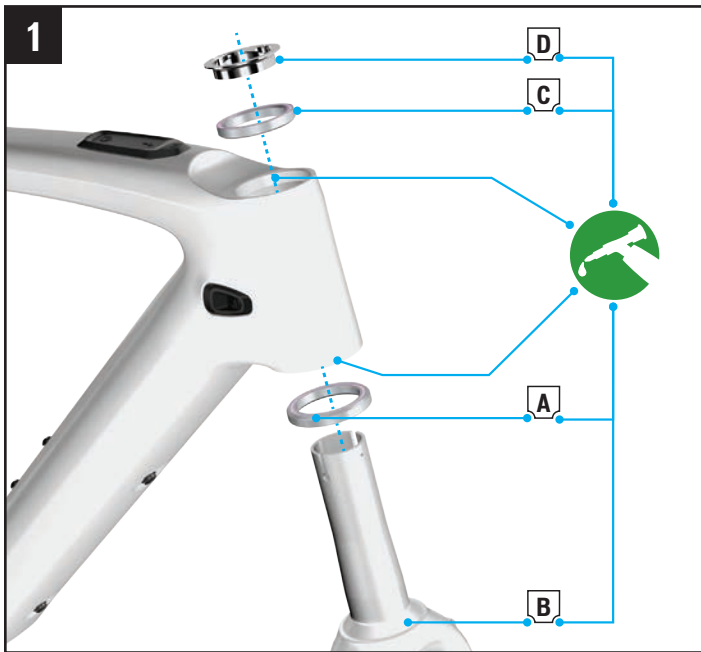

■ Fig. 1: Grease, then install the lower bearing (A) on the fork (B). Insert the fork into the head tube, then grease and install the upper bearing (C) and compression ring (D) on the steerer tube.

⚠ CAUTION: Ensure that the compression ring slot is facing toward the rear of the bicycle. Do not place the slot near the headset preload bolts.

- Fig. 2: Grease, then install the steerer tube collar bolt, washer, and barrel. Install the steerer tube collar (E) onto the fork with the bolt head facing the drive-side of the bicycle as shown.
- Fig. 2: Apply blue Loctite, then install the locator bolt (F) in the collar to lock the collar on the steerer tube. Tighten until snug. Do not exceed 9.5 in-lbf / 1.0 Nm.

⚠ WARNING! To ensure that the collar and fork locator bolt holes are aligned with each other, place a 2 mm hex key through the holes before installing and tightening the locator bolt. Ensure that the headset adjustment set screws are backed out before installing the collar.

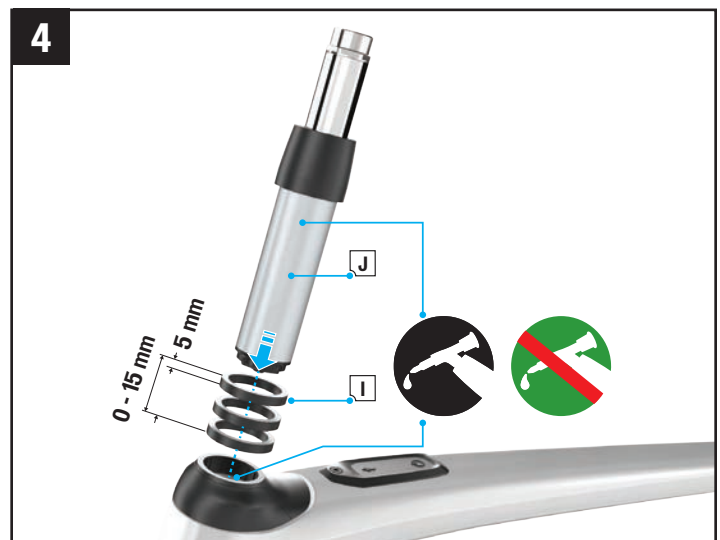
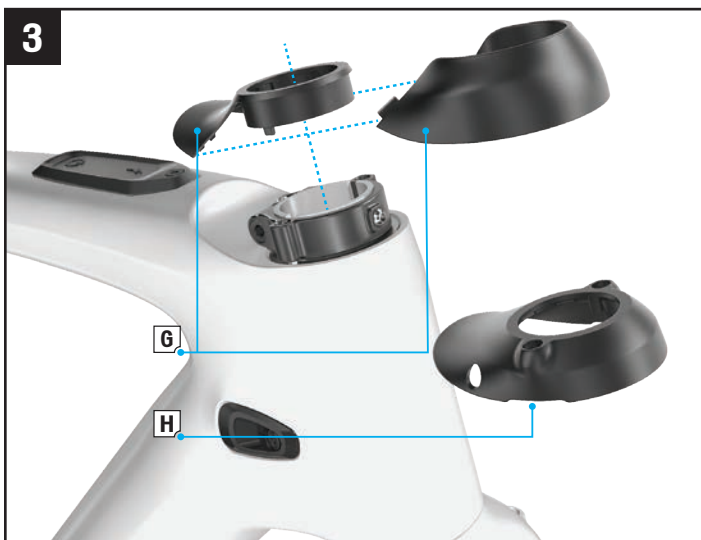

■ Fig. 3: Choose the tall (G) or short (H) headset cap, then place it over the steerer tube collar. If you are using the tall headset cap, leave the front half off during this step.

i Please note the short headset cap is not available on all Future Shock equipped bicycle models.

- Fig. 4: Install 0-15 mm of steerer tube spacers (I) on the cartridge assembly (J). Apply carbon assembly compound on the Future Shock, then insert the cartridge assembly into the steerer tube. Do not use grease.

WARNING! To ensure proper insertion of the Future Shock cartridge in the steerer tube, do not install more than 15 mm of spacers over the short or tall headset caps. Ensure there is no grease between the steerer tube and the cartridge. Grease can cause the cartridge to slip, which can result in a loss of control.

Specialized recommends the application of carbon assembly compound (or carbon paste) between the cartridge and steerer tube to increase friction. See your Authorized Specialized Retailer if you have any questions.

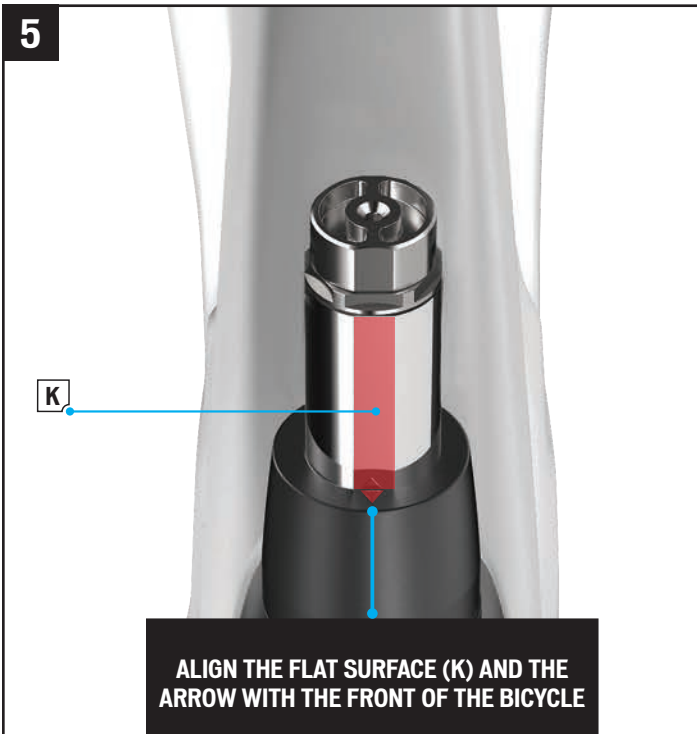

■ Fig. 5: Check that the arrow on the rubber boot aligns with one of the three flat surfaces. Align the cartridge so that the flat surface (K) and arrow face the front of the bicycle.

■ Fig. 6: Install a stem shim (L) on the cartridge. Use a thick shim for a standard 1-1/8" stem, or a thin shim for the SW Future Stem. The shim slot must align with the stem toward the back of the bicycle.

The SW Future Stem is compatible with all Future Shocks.

The Venge Accessory Mount (S189900104) is compatible with the SL faceplate (S199900064) or the SW Future Stem.

The SL faceplate is only compatible with the SW Future Stems and SL stems.

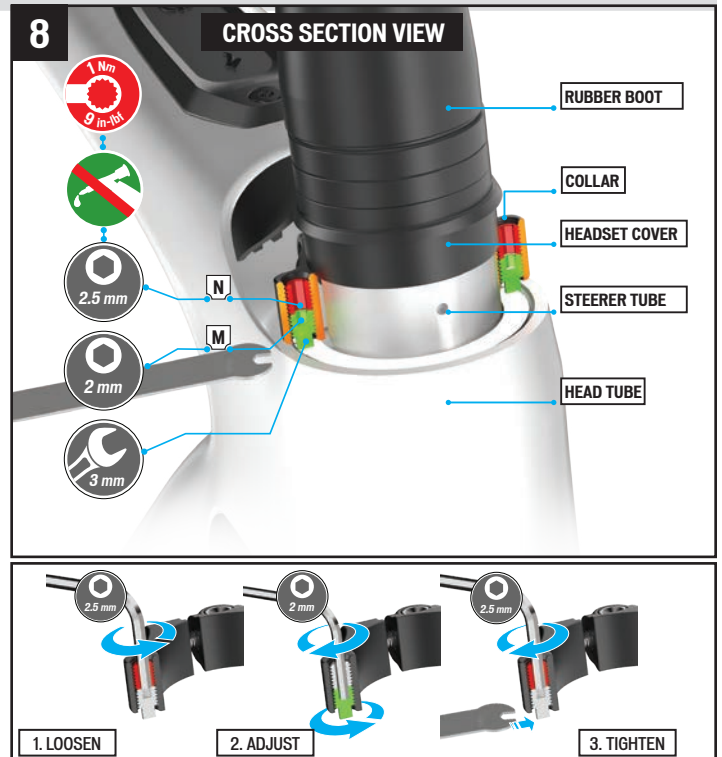
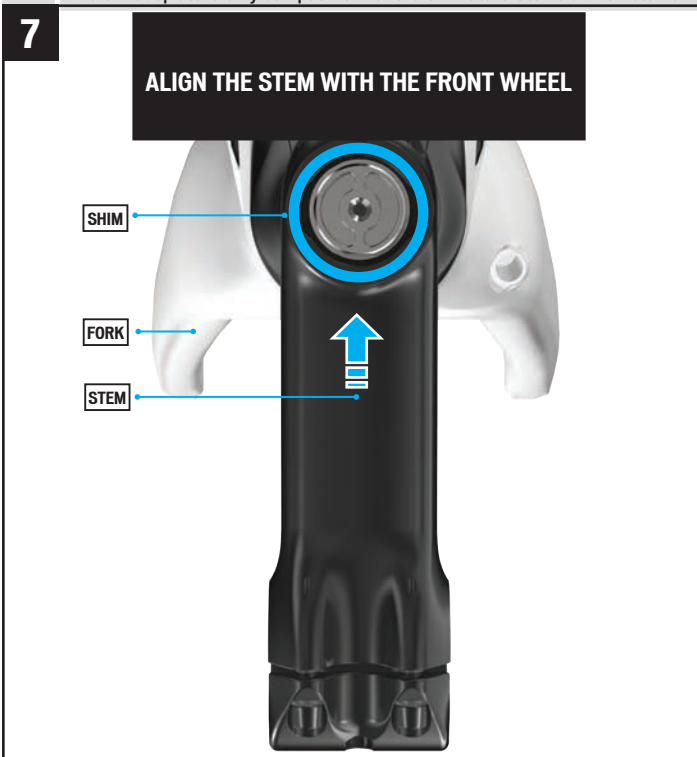

■ Fig. 7: Install the stem on the cartridge, then align the stem with the front wheel. Torque the stem according to the manufacturer specifications. Install the handlebar and brakes according to the brake manufacturer's instructions.

- **NON-DAMPED FUTURE SHOCK:** Install the top cap (Fig. 1-A below, **finger tight**).
- **Fig. 8:** Make sure the locking screws are loosened (N), then adjust the two preload screws (M) using a 2 mm hex key until they both contact the compression ring. Gradually and evenly alternate between the two preload screws while engaging the front brake and rocking the bicycle back-and-forth until any movement/looseness is eliminated and the headset rotates freely.
- Place the supplied 3 mm open wrench on the preload screws (M) below the collar, then torque the locking screws (N) to 9 in-lbf / 1.0 Nm down onto the preload screws to lock them in place. **DO NOT GREASE THE LOCKING SCREWS!**

 To access the preload screw (lower), the 2 mm hex key goes through the upper locking screw. The upper locking screw is tightened using a 2.5 mm hex key.

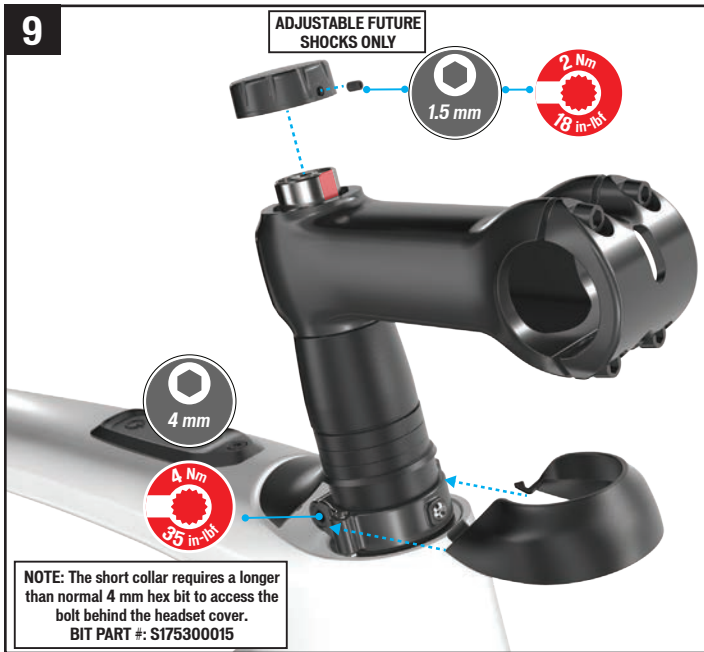

- **Fig. 9:** Torque the steerer tube collar bolt to 35 in-lbf / 4.0 Nm. If you are using the tall headset cap, insert the outer piece and snap it into place.

 **WARNING!** When the cartridge is installed, ensure that the steerer tube collar bolt is greased and torqued to specification. Do not tighten the collar without the cartridge installed. An improperly installed and/or tightened collar may cause you to lose control and fall.

- **Fig. 9 (adjustable Future Shock only):** The adjuster dial must be removed before the stem is installed. Loosen the set screw on the side of the adjuster knob to remove it. To re-install, align the adjuster dial set screw with the flat surface (Fig.5 K) on the top of the Future Shock. Torque the set screw to 18 in-lbf / 2.0 Nm.

ADJUSTING THE STACK HEIGHT

- Remove the top cap and stem.
- Partially back out the set screws, then loosen the collar pinch bolt.
- Remove the cartridge from the steerer tube. **DO NOT REMOVE THE BOOT!** The boot is very tight and difficult to get back on, and exposes the internals to contamination.
- Refer to Fig. 3-8 for installation steps on adjusting the stack height.

CHANGING THE SPRING RATE (non-damped models)

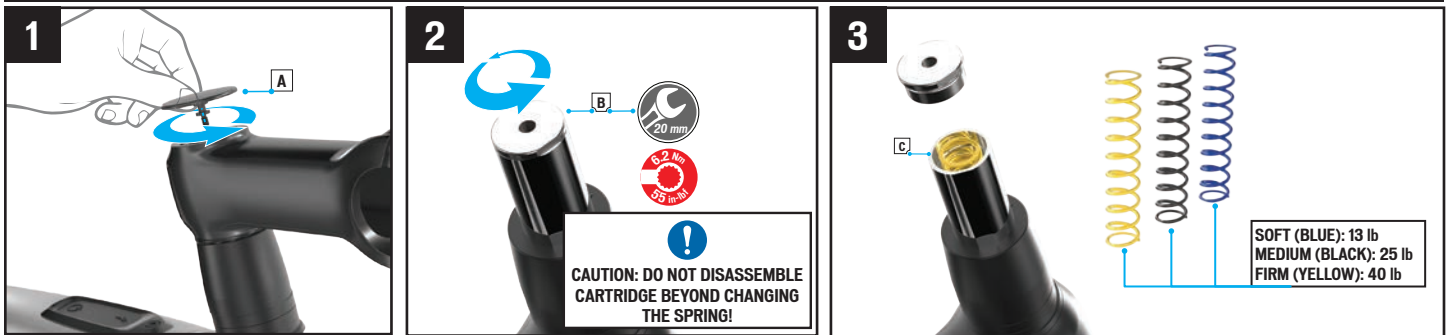

- To change the spring rate, remove the cap (Fig. 1-A), stem and shim, then unscrew the cartridge top cover (Fig. 2-B) using a 20 mm cone wrench.
- Install the desired spring (Fig. 3-C) then reinstall the top cover. Tighten to 55 in-lbf / 6.2 Nm (using a Crow's Foot), or until the cover is snug (using a cone wrench).

 **CAUTION:** When loosening the top cover to change the spring, leave the cartridge in the fork clamped by the collar. Do not place the cartridge in a table vise!

HEADSET/STACK HEIGHT ADJUSTMENT CHECKLIST

■ USE A TORQUE WRENCH!	■ Is the headset adjusted?
■ Is the arrow on the cartridge boot aligned toward the front of the bicycle?	■ Are the set screws applying even pressure with the lock screws tightened down?
■ Is the collar pinch bolt tight?	■ Are the stem bolts tight?