

ANTARES

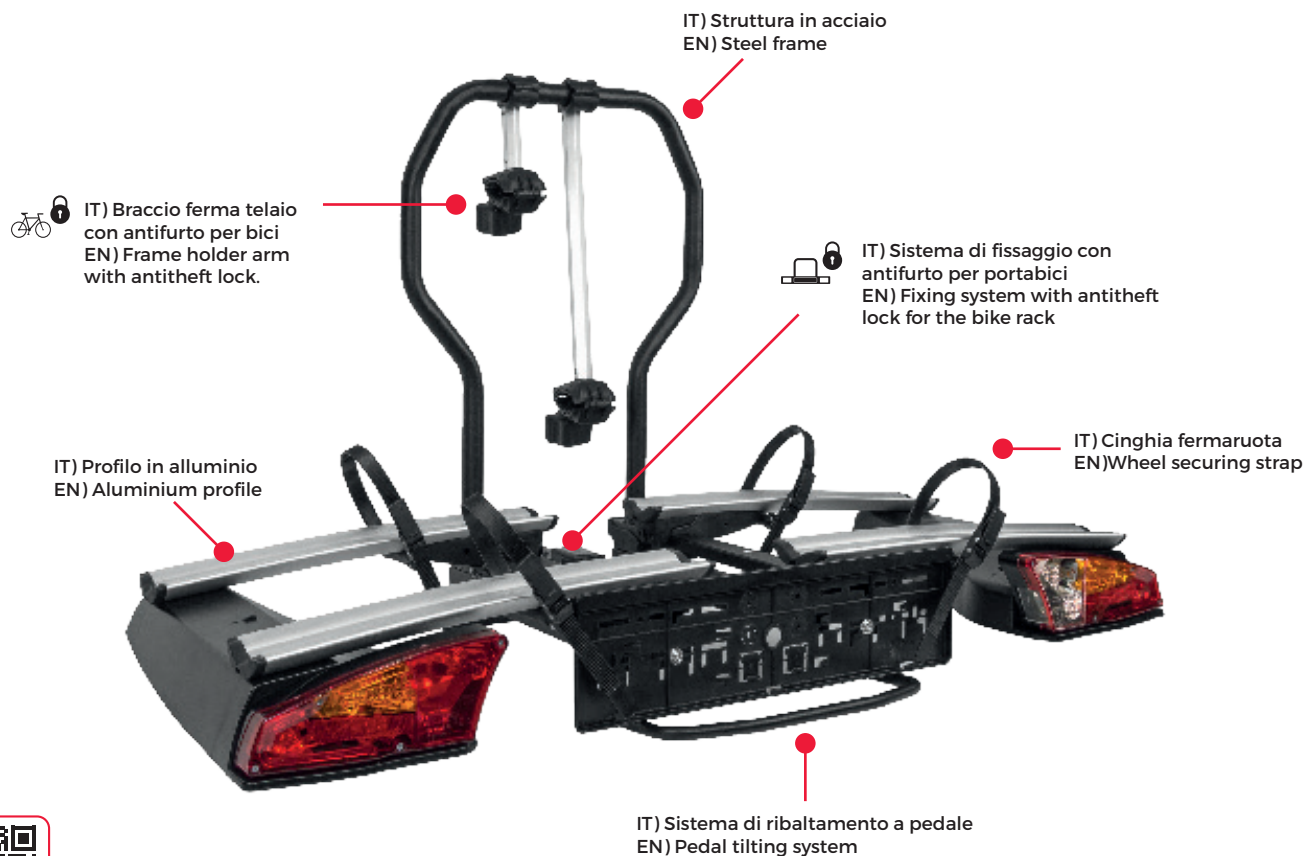

IT) Portabici da gancio richiudibile con sistema di aggancio rapido, telaio in acciaio ad alta resistenza e profili in alluminio. Dotato di sistema di ribaltamento a pedale e di doppio antifurto.

EN) Foldable towbar bike rack with quick lock system, sturdy steel frame and large aluminium wheel rails. Antares is equipped with a pedal tilting system and double antitheft system.



Antares
Art. 000105000000



Art. 000110200000



Antares plus
Art. 000103400000



ANTARES / ANTARES PLUS

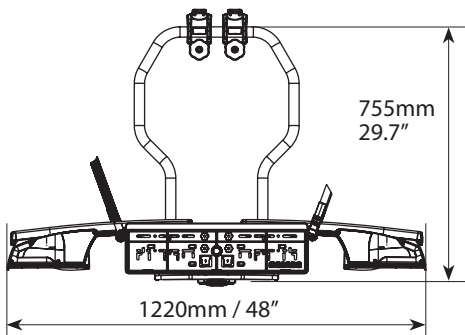

ANTARES / ANTARES PLUS

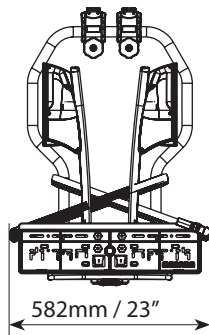

ANTARES

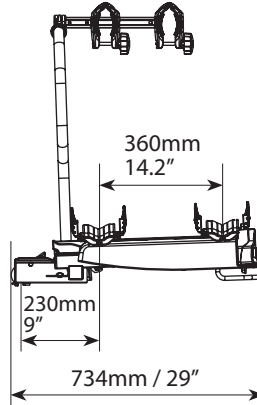



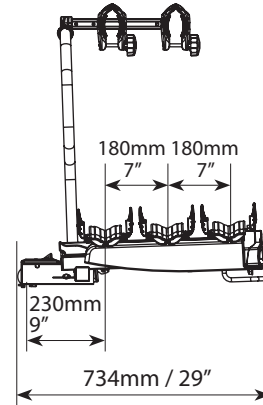

ANTARES PLUS



Art.	Antares	000105000000
	Antares plus	000103400000
	Antares	19kg/42lb
	Antares plus	21kg/46.3lb
Materiale Material Matière	Alluminio e acciaio Aluminium and steel Aluminium und Stahl Aluminio y acero Aluminium et acier	
	Antares	max 60kg / 132lb
	Antares plus	max 60kg / 132lb
	✓	
	✓	
Max	Antares	2+1 (optional kit 000110200000)
	Antares plus	3
Fat bike	✓	
E-bike	✓	

**COMPATIBILITÀ BICI
BIKE COMPATIBILITY
VÉLOS COMPATIBLES
BICICLETAS COMPATIBLES
PASSENDE FAHRRÄDER**

Mod.				
ANTARES / ANTARES PLUS	 min: 30mm/1.2" max: 50mm/2.3"	 min: 30x60mm/1.2x2.3" max: 50x70mm/2x2.7"	min 22" max 29"	max 110mm/4.3"
				max 1220mm/48" Optional kit 000112500000 max 1320mm/52"

Mod.	ANTARES	ANTARES PLUS
Art.N°	000105000000	00103400000
	L x W x H : 77,5x59x80 cm / 30.5x23.2x31.5" 📦 25 Kg / 55lb	L x W x H : 77,5x59x80 cm / 30.5x23.2x31.5" 📦 27 Kg / 59.5lb
	L x W x H : 80x120x177 cm / 31.5x47.2x69.7" 📦 121 Kg / 266.7lb Pz: 4	L x W x H : 80x120x177 cm / 31.5x47.2x69.7" 📦 129 Kg / 284.4lb Pz: 4
Ean-13	 8 003 168 036 234	 8 003 168 035 497

F.lli Menabò s.r.l.

Via 8 Marzo 3,
42025 Cavriago (RE), Italy
customer@flli-menabo.it
www.menabocaraccessories.com