

MAZDA

GB	LED Door illumination Installation instruction
D	LED-Türbeleuchtung Einbauanleitung
E	Iluminación de la puerta del LED Instrucciones de montaje
F	Eclairage de porte LED Notice de montage
I	Illuminazione LED porta Istruzioni di montaggio
P	Iluminação da porta do LED Instruções de montagem
NL	LED Deur verlichting Inbouw-instructie
DK	LED døren belysning Monteringsvejledning

N	LED-dørs belysning Monteringsvejledning
S	LED Dörr Illumination Monteringsanvisning
SF	LED oven valaistus Asennusohje
CZ	Osvetlenie LED dvere Návod k montáži
H	LED Ajtó megvilágítás Beszerelési utasítás
PL	Oświetlenie LED Drzwi Instrukcja zabudowy
GR	Φωτισμός LED Πόρτα Οδηγίες τοποθέτησης
RUS	Светодиодная подсветка двери инструкция по монтажу

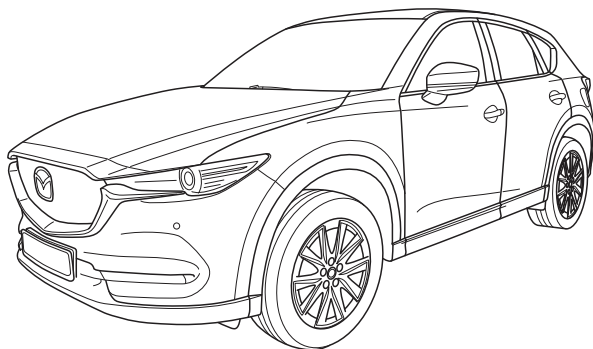

MAZDA CX-5 KF

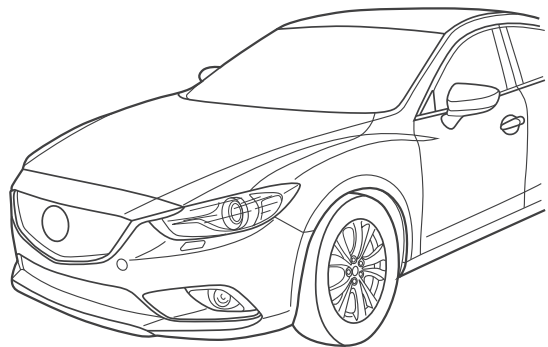

	MAZDA 6 GJ
	MAZDA 6 GH
	JMZGJ *****120400 →
	JMZGL *****500015 →

Part No: C850-V7-540B

Date: 23-04-'18

© Copyrights MAZDA

Sheet 1 of 50

Expert Fitment Required
Montage durch Fachwerkstatt erforderlich
Montaje sólo por el concesionario
Montage par spécialiste nécessaire
E' necessario in officina specializzata
Especialista em montagem requerido
Montage door vakman nodig
Montage ved professionelt værksted påkrævet
Nødvendig med montering fra fagvejværksted
Verkstadsmontage erfordras
Asennus tarpeen merkkikorjaamossa
Montáž ve specializované díně nutná
A szereléshez szakműhely kell
Konieczny montaż przez warsztat specjalistyczny
Να τοποθεη από συνεργείο
необходим монтаж специалиста

GB
INSTRUCTION SHEET

Area of application:

- Not for Do It Yourself fitment.
- Check Radio Code.
- Disconnect the battery earth cable.
- To avoid damage to the wiring harness, ensure contact with sharp edges is prevented.
- Install parts as shown on illustrations.
- Re-connect battery.
- Re-fit panels, ensure that the wiring harness and other components are neatly and securely located.

D
EINBAUANLEITUNG

Verwendungsbereich:

- Montage durch Fachwerkstatt erforderlich
- Notieren Sie den Radiocode
- Massekabel von Batterie abklemmen.
- Zur Vermeidung von Beschädigungen an der Kabelisolation ist Berührung mit scharfen Kanten zu vermeiden.
- Teile gemäß Abbildung montieren.
- Batterie wieder anschließen.
- Paneele wieder anbringen; achten Sie darauf, daß der Kabelbaum und andere Teile ordnungsgemäß und genau positioniert sind.

I
ISTRUZIONI DI MONTAGGIO

Ambito di utilizzazione:

- Non per "do-it-yourself"
- Annotare il codice di sicurezza della radio
- Staccare il cavo di massa dalla batteria
- Allo scopo di evitare danni all'isolazione dei cavi, evitare di metterli a contatto con spigoli acuti.
- Montare le parti secondo quanto rilevabile delle illustrazioni.
- Riconnettere la batteria.
- Rimettere in posizione i pannelli; far ben attenzione che il fascio di cavi e le altre parti siano state posizionate con esattezza e nella dovuta maniera.

E
INSTRUCCIONES DE MONTAJE

Campo de aplicación:

- "No para montarlo uno mismo"
- Anote el código de seguridad de la radio.
- Desconectar el cable de masa de la batería.
- A efectos de evitar desperfectos en el aislamiento del cable, hay que evitar el contacto con aristas cortantes.
- Montar las piezas tal como se indica en las figuras.
- Vuelva a conectar la batería.
- Volver a colocar los paneles; preste atención a que el mazo del cable y las demás piezas tengan la posición correcta y precisa.

F
NOTICE DE MONTAGE DU KIT

Utilisation:

- Le montage doit être effectué par un spécialiste.
- Notez le code de l'autoradio.
- Débranchez le câble de masse de la batterie.
- Eviter tout contact avec des arêtes vives afin de ne pas endommager l'isolation des câbles.
- Montez les pièces selon les figures.
- Reconnectez la batterie.
- Remettre le panneau; veillez à ce que le faisceau et les autres pièces soient positionnés correctement et avec la précision requise.

NL
MONTAGEAANWIJZING

Toepassingsgebied:

- Niet voor "doe-het-zelf"-montage.
- Radiocode noteren.
- Massakabel van accu losmaken.
- Ter vermindering van beschadigingen aan de isolatie van de elektrokit dient contact met scherpe kanten te worden vermeden.
- Delen overeenkomstig afbeelding monteren.
- Accu weer aansluiten.
- Panelen weer monteren; let erop, dat de kabelboom en andere delen correct en netjes gepositioneerd worden.

P
INSTRUÇÕES DE MONTAGEM

Campo de utilização:

- No é destinado à auto-montagem”
- Tome nota do número de código do rádio.
- Separe o cabo de terra do acumulador.
- Para não se danificar a isolamento dos cabos, é conveniente evitar-se contacto com arestas afiadas.
- Monte as partes conforme ilustrado.
- Recolocar a bateria
- Tornar a colocar os painéis; verificar se a árvore de cabos e outras peças estão na posição exacta e prescrita.

N
MONTERINGSVEILEDNING

Bruksområde:

- ”Ikke for selvmontering”
- Noter deg radiokoden
- Klem jordkabelen av batteriet.
- For å unngå skader på kabelisoleringen må berøring av skarpe kanter unngås.
- Monter alle deler i henhold til illustrasjonene.
- Tilkoppl batteriet igjen.
- Monter panelene igjen, og pass på at kabelbunten og andre deler er anbrakt ordentlig og på riktig sted.

S
MONTERINGSANVISNING

Användningsområde:

- ”Ej för självmontage”.
- Anteckna radiokoden.
- Lossa stomkabeln från batteriet.
- För att förhindra skador på ledningarnas isolation skall berøring med vassa kanter undvikas.
- Montera detaljerna enligt figurerna
- Anslut batteriet igen.
- Sätt tillbaka panelerna igen; kontrollera noga att ledningsmattan och andra detaljer ligger på rätt plats.

DK
MONTAGEVEJLEDNING

Anvendelsesområde:

- ”Ikke til do-it-yourself montering”
- Noter radiokoden
- Stelkabel fjernes fra batteri.
- Berøring med skarpe kanter skal undgås for at undgå beskadigelse af kabelisoleringen.
- Dele skal monteres i henhold til illustrationer.
- Tilslut batteri igen.
- Paneler fastgøres igen; vær opmærksom på, at kabelsamlingen og andre dele placeres korrekt og præcist.

SF
ASENNUSOHJE

Käyttöalue:

- ”Ei Tee-se-itse-asennukseen”.
- Merkitse radion koodi muistiin.
- Erotta maadoitusjohto akusta
- Pidä huoli myös siitä, että kaapelointi on korin kiinnityksen myötäinen ja kiinnitetty huolellisesti muihin liikkuviin osiin.
- Asenna osat kuvien mukaan.
- Kytke akku takaisin.
- Aseta paneelit paikalleen; tarkista, että kaapelointi ja muut osat ovat asianmukaisesti ja tarkalleen paikoillaan.

CZ
NÁVOD K MONTÁŽI

Oblast použití:

- Není určeno pro neodbornou montáž.
- Poznamenejte si kód rádia.
- Odpojte zemnicí kabel od baterie.
- Zabraňte tomu, aby se kabely poškodily tím, že jsou položeny na ostrých hranách.
- Montujte části podle vyobrazení
- Opět připojit baterii.
- Opět připevňte panely; dbejte na to, aby svazek kabelů a ostatní části byly uloženy na správném místě.



BESZERELÉSI UTASÍTÁSA

Melyik gépjárműhöz:

- A beszerelés csak szakműhelyben hajtható végre
- Jegyezze meg a rádió biztonsági kódszámát.
- Húzza le az akkumulátor testkábeljét.
- A kábelszigetelés megsérülésének elkerülésére ügyeljen arra, hogy a kábel ne juthasson érintkezésbe éles peremű alkatrészekkel.
- Az alkatrészeket az ábrák szerint szerelje be.
- Ismét csatlakoztassa az akkumulátort.
- Szerelje vissza a fedőlapokat, ügyeljen arra, hogy a kábelek és a többi alkatrészek pontosan a számukra kijelölt helyen maradjanak.



INSTRUKCJA MONTAŻU

Zakres stosowania:

- Zestaw nie jest przeznaczony do montażu we własnym zakresie.
- Zanotować kod radia.
- Odłączyć przewód masy od akumulatora.
- Dla zapobieżenia uszkodzeniu izolacji chronić przed zetknięciem z ostrymi krawędziami.
- Zamontować części zgodnie z rysunkiem.
- Ponownie podłączyć akumulator.
- Na powrót osadzić osłony; zadbać aby wiązka kablowa i inne części były właściwie i dokładnie ułożone.



ΟΔΗΓΙΕΣ ΤΟΠΟΘΕΤΗΣΗΣ

Τομέας εφαρμογής:

- Δεν επιτρέπεται να το τοποθετήσετε οι ίδιοι σας.
- Σημειώστε τον κωδικό του ραδιοφώνου.
- Αποσυνδέστε το καλώδιο γείωσης από τη μπαταρία.
- Για να αποφευχθούν ζημιές στη μόνωση καλωδίων, να αποφεύγεται η επαφή των με αιχμηρές ακμές.
- Τοποθέτηση των μερών σύμφωνα με τις Εικόνες.
- Συνδέστε πάλι τη μπαταρία.
- Τοποθετήστε πάλι το κάλυμμα· προσοχή, η πλεξούδα καλωδίων και άλλα μέρη να είναι τοποθετημένα ακριβώς και σύμφωνα με τους κανονισμούς.



ИНСТРУКЦИЯ МОНТАЖА

Область применения:

- не для самостоятельного монтажа
- запишите код безопасности радиоприемника
- отключите у аккумулятора заземление на массу
- для избежания повреждения изоляции кабеля избегайте острых поверхностей
- части монтировать согласно рисунку
- подключите аккумулятор
- понели собрать; обратите внимание чтобы кабель и другие части были правильно и точно расположены.

Mazda Color Table

	GB	D	E	F	I	P	NL	DK
B	Black	Schwarz	Negro	Noir	Nero	Preto	Zwart	Sort
BR	Brown	Braun	Marrón	Marron	Marrone	Castanho	Bruin	Brun
DG	Dark green	Dunkelgrün	Verde oscuro	Vert foncé	Verde scuro	Verde-escuro	Donkergroen	Mørkegrøn
DL	Dark blue	Dunkelblau	Azul oscuro	Bleu foncé	Blu scuro	Azul-escuro	Donkerblauw	Mørkeblå
G	Green	Grün	Verde	Vert	Verde	Verde	Groen	Grøn
GY	Grey	Grau	Gris	Gris	Grigio	Cinzento	Grijs	Grå
L	Blue	Blau	Azul	Bleu	Blu	Azul	Blauw	Blå
LB	Light blue	Hellblau	Azul claro	Bleu clair	Blu chiaro	Azul-claro	Lichtblauw	Lyseblå
LG	Light green	Hellgrün	Verde claro	Vert clair	Verde chiaro	Verde-claro	Lichtgroen	Lysegrøn
N	Natural colour	Naturfarben	Color natural	Nature	Colori naturali	Cores naturais	Naturel	Naturfarvet
O	Orange	Orange	Naranja	Orange	Arancione	Laranja	Oranje	Orange
P	Pink	Rosa	Rosa	Rose	Rosa	Rosa	Rosé	Rosa
PU	Purple	Purpur	Púrpura	Pourpre	Rosso porpora	Púrpura	Paars	Purper
R	Red	Rot	Rojo	Rouge	Rosso	Vermelho	Rood	Rød
SB	Sky blue	Himmelblau	Azul cielo	Bleu ciel	Celeste	Azul-céu	Hemelsblauw	Himmelblå
T	Yellow brown	Gelbbraun	Amarillo-marrón	Marron-jaune	Giallomarrone	Castanho-amarelado	Geelbruin	Gulbrun
V	Violet	Violett	Violeta	Violet	Viola	Violeta	Violet	Violet
W	White	Weiß	Blanco	Blanc	Bianco	Branco	Wit	Hvid
Y	Yellow	Gelb	Amarillo	Jaune	Giallo	Amarelo	Geel	GulHvid

	N	S	SF	CZ	H	PL	GR	RUS
B	Sort	Svart	Musta	Černá	Fekete	Czarna	Μαύρο	Черный
BR	Brun	Brun	Ruskea	Hnědá	Barna	Brazowa	Καφέ	Коричневый
DG	Mørkegrønn	Mörkgrön	Tummanvihreä	Tmavozelená	Sötétzöld	Ciemnozielona	Σκούρο πράσινο	Темно Зеленый
DL	Mørkeblå	Mörkblå	Tummansininen	Tmavomodrá	Sötétkék	Granatowa	Σκούρο μπλε	Темно Синий
G	Grønn	Grön	Vihreä	Zelená	Zöld	Zielona	Πράσινο	ТЗеленый
GY	Grå	Grå	Harmaa	Šedá	Szürke	Szara	Γκρι	Серый
L	Blå	Blå	Sininen	Modrá	Kék	Niebieska	Μπλε	Синий
LB	Lyseblå	Ljusblå	Vaaleansininen	Bleděmodrá	Világoskék	Jasnoniebieska	Ανοιχτό μπλε	Светло Синий
LG	Lysegrønn	Ljusgrön	Vaaleanvihreä	Světlezelená	Világoszöld	Jasnozielona	Ανοιχτό πράσινο	Светло Зеленый
N	Naturfarger	Naturlärger	Luonnonväri	Přírodní barva	Természetes színű	Barwy naturalne	Φυσικά χρώματα	природный
O	Orange	Orange	Oranssi	Oranžová	Narancs	Pomarańczowa	Πορτοκαλί	Оранжевый
P	Rosa	Rosa	Rosa	Růžová	Rózsaszín	Różowa	Ροζ	Розовый
PU	Purpur	Purpur	Purppura	Purpurová	Bíborvörös	Purpurowa	Μοβ	Сиреневый
R	Rød	Röd	Punainen	Červená	Piros	Czerwona	Κόκκινο	Красный
SB	Himmelblå	Himmelsblå	Taivaansininen	Blankytná	Égszínkék	Bękitna	Γαλάζιο	лазурный
T	Gulbrun	Gulbrun	Keltaisenruskea	Žlutohnědá	Sárgásbarna	Żółto-brązowa	Κίτρινοκαφέ	Желто-коричневый
V	Fiolett	Violett	Violett	Fialová	Ibolyakék	Fioletowa	Μοβν	фиолетовый
W	Hvit	Vit	Valkoinen	Bílá	Fehér	Biała	Λευκό	Белый
Y	Gul	Gul	Keltainen	Žlutá	Sárga	Żółta	Κίτρινο	Желтый

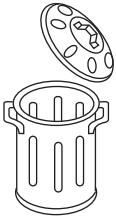

- (GB)** Throw away
- (D)** Wegwerfen
- (E)** Tirar
- (F)** Jeter
- (I)** Buttare via
- (P)** Wyrzucić
- (NL)** Weggooien
- (DK)** Smide
- (N)** Kaste bort
- (S)** Kasta bort
- (SF)** Heittää pois
- (CZ)** Zahodit
- (H)** Eldob
- (PL)** Wyrzucić
- (GR)** πετάτε
- (RUS)** выбрасывать

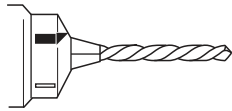

- (GB)** Use drill
- (D)** Bohrer verwenden
- (E)** Utilizar exploración
- (F)** Utiliser percer
- (I)** Utilizzare trapano
- (P)** Usar perforar
- (NL)** Gebruik boormachine
- (DK)** Brugte bore
- (N)** Bruke drill
- (S)** Använda borra
- (SF)** Käytä poraa
- (CZ)** Použít vrták
- (H)** Használata fúró
- (PL)** Używać wywiercić
- (GR)** χρησιμοποιήστε τρυπάνι
- (RUS)** использовать бурения

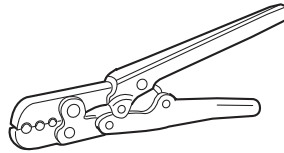

- (GB)** Use Crimping Tool
- (D)** Kabelschuhzange verwenden
- (E)** Utilizar alicates para terminales de cables
- (F)** Use pince pour broches de câble
- (I)** Utilizzare pinza per capocorda
- (P)** Sujeitar com fita adesiva
- (NL)** Kabelschoentang
- (DK)** Kabelskotang anvendes
- (N)** Bruk kabelskotang
- (S)** Använd kabelskotång
- (SF)** Käytä kaapelikenkäpihtejä
- (CZ)** Použít kleště na kabelová oka
- (H)** Használjon kábelsarufogót
- (PL)** Stosować cęgi do końcówek kablowych
- (GR)** Χρησιμοποιείτε πένσα πέδιλων αλωδίων
- (RUS)** Используйте щипцы с кабельным наконечником

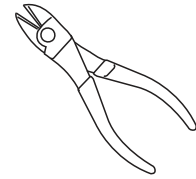

- (GB)** Use side cutters
- (D)** Seitenschneider verwenden
- (E)** Utilizar cortadores laterales
- (F)** Utiliser une pince coupante
- (I)** Utilizzare frese laterali
- (P)** Use estiletas
- (NL)** Gebruik zijknijptang
- (DK)** Brugte sideskær
- (N)** Bruke sideskjær
- (S)** Använd sidavbitare
- (SF)** Käyttää sivuleikkurit
- (CZ)** Použít boční štípací kleště
- (H)** Használata Oldalcsípófogók
- (PL)** Używać noży bocznych
- (GR)** χρησιμοποιήστε κόφτες ακρών
- (RUS)** использовать бокорезы



- (GB)** Tape up
- (DE)** Mit Klebeband befestigen
- (ES)** Fijar con cinta adhesiva
- (FR)** Fixer avec ruban adhésif
- (IT)** Fissare con nastro adesivo
- (PT)** Sujeita adesiva
- (NL)** Vastzetten met tape
- (DA)** Fastgøres med tape
- (NO)** Fest fast med klebeband
- (SV)** Fästad med tejp
- (FI)** Kiinnitys teipillä
- (CS)** Upevnit lepicí páskou
- (HU)** Rögzítse ragasztószalaggal
- (PL)** Umocować taśmą samoprzylepną
- (EL)** Στερέωση με κολλητική ταινία
- (RU)** Прикрепите клейкой лентой



- (GB)** Warning
- (D)** Achtung
- (E)** Atención
- (F)** Attention
- (I)** Attenzione
- (P)** Atenção
- (NL)** Let op
- (DK)** Bemærk
- (N)** Pass på
- (S)** Varning
- (SF)** Huomio
- (CZ)** Pozor
- (H)** Figyelem
- (PL)** Uwaga
- (GR)** Προσχή
- (RUS)** Осторожно



- (GB)** Movement Arrow
- (D)** Bewegungspfeil
- (E)** Flecha de movimiento
- (F)** Flèche indiquant sens du mouvement
- (I)** Freccia di movimento
- (P)** Flexa de movimento
- (NL)** Richtingspijl
- (DK)** Bevægelsespil
- (N)** Bevegelsespil
- (S)** Rörelsepil
- (SF)** Liikesuuntanuoli
- (CZ)** Šipka pohybu
- (H)** Mozgásirányjelző nyíl
- (PL)** Strzałka kierunku ruchu
- (GR)** Βέλος κίνησης
- (RUS)** Стрелка по направлению

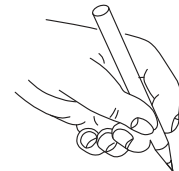

- (GB)** Mark with pencil
- (D)** Markieren mit Bleistift
- (E)** Marcar con lápiz
- (F)** Marquer avec un crayon
- (I)** Segnare con la matita
- (P)** Marcar com lápis
- (NL)** Markeer met potlood
- (DK)** Markere med en blyant
- (N)** Merke med blyant
- (S)** Markera med penna
- (SF)** Merkitse lyijykynällä
- (CZ)** Označit tužkou
- (H)** Jelölje ceruzával
- (PL)** Zaznaczyć ołówkiem
- (GR)** σήμα με το μολύβι
- (RUS)** пометить карандашом



- (GB)** Location/Position Arrow
- (D)** Positionspfeil
- (E)** Flecha de posición
- (F)** Flèche de Position
- (I)** Freccia di posizione
- (P)** Flexa de posição
- (NL)** Lokatie/Positie pijl
- (DK)** Lokaliseringspil
- (N)** Posisjonspil
- (S)** Positionpil
- (SP)** Paikannusnuoli
- (CZ)** Šipka na pozici
- (H)** Helyzetjelző nyíl
- (PL)** Strzałka położenia
- (GR)** Βέλος θέσης
- (RUS)** Позиция



- (GB)** Disconnect
- (D)** Abklemmen
- (E)** Desconectar
- (F)** Déconnecter
- (I)** Staccare
- (P)** Desligar
- (NL)** Frakoblen
- (DK)** Frakobles
- (N)** Klem av
- (S)** Koppla los
- (SF)** Irrota
- (CZ)** Odpojit
- (H)** Szakítsa meg, kapcsolja szét
- (PL)** Rozłączyć
- (GR)** Αποσύνδεση
- (RUS)** Разъедините



- (GB)** Connect
- (D)** Verbinden
- (E)** Conectar
- (F)** Connecter
- (I)** Collegare
- (P)** Ligar
- (NL)** In elkaar
- (DK)** Kobles
- (N)** Tilkopling
- (S)** Ansult
- (SF)** Yhdistä
- (CZ)** Spojit
- (H)** Kapcsolja össze
- (PL)** Połączyć
- (GR)** Σύνδεση
- (RUS)** Соедините



- (GB)** See Workshop Manual
- (D)** Siehe Werkstatthandbuch
- (E)** Ver manual de taller
- (F)** Voir Manuel d'atelier
- (I)** Vedere manuale officina
- (P)** Cf. o manual da oficina
- (NL)** Zie werkplaatshandboek
- (DK)** Se værkstedshåndbog
- (N)** Se verkstedshåndboka
- (S)** Se verkstadshandboken
- (SF)** Katso korjaamon käsikirjasta
- (CZ)** Viz dílenskou příručku
- (H)** Lásd a Műhely-kézikönyvben
- (PL)** Patrz podręcznik warsztatowy
- (GR)** λέπε Εγχειρίδιο Συνεργείου
- (RUS)** Смотри руководство для мастерской



- (GB)** Mirror image
- (D)** Spiegelbild
- (E)** Imagen simétrica
- (F)** Image de miroir
- (I)** Immagine dello specchio
- (P)** Imagem do espelho
- (NL)** Mirror beeld
- (DK)** Spejlbilde
- (N)** Speilbilde
- (S)** Spegelbild
- (SF)** Peilikuva
- (CZ)** Věrný obraz
- (H)** Tükürrkép
- (PL)** Odbicie lustrzane
- (GR)** εικ ανακθρεφτών
- (RUS)** Зеркальное отражение



- (GB)** Look/See
- (D)** Siehe
- (E)** Ver
- (F)** Voir
- (I)** Vedere
- (P)** Cf.
- (NL)** Kijken naar
- (DK)** Se
- (N)** Se
- (S)** Se
- (SF)** Katso
- (CZ)** Viz
- (H)** Lásd
- (PL)** Patrz
- (GR)** Βλέπε
- (RUS)** Сомтри



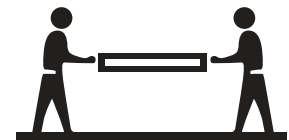

- (GB)** Information
- (D)** Informationen
- (E)** Información
- (F)** Informations
- (I)** Informazioni
- (P)** Informação
- (NL)** Informatie
- (DK)** Information
- (N)** Informasjon
- (S)** Uppgifter
- (SF)** Tiedot
- (CZ)** Informace
- (H)** Információ
- (PL)** Informacja
- (GR)** πληροφορίες
- (RUS)** информация



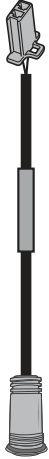
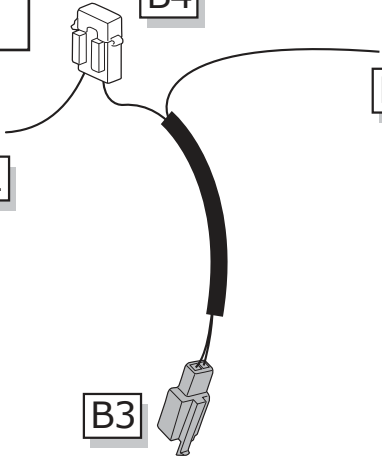
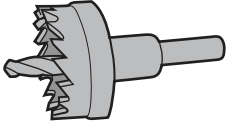
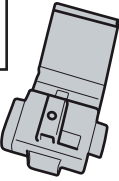
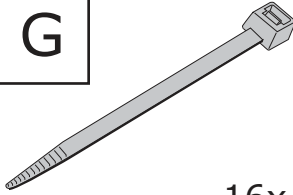
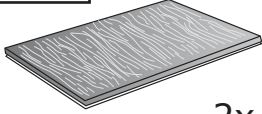
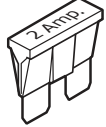
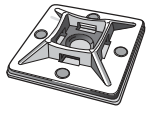
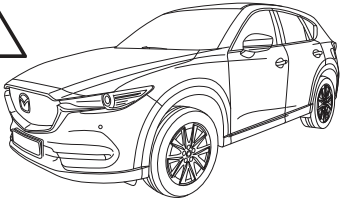
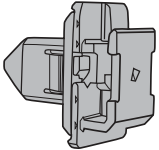
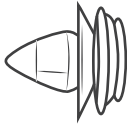
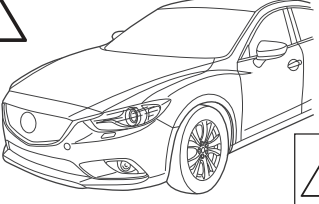
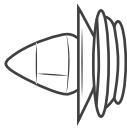

- (GB)** 2 Man Operation Required
- (D)** Nur zu zweit ausführen
- (E)** Realizar sólo entre dos personas
- (F)** Toujours s'y mettre de deux
- (I)** Da eseguire soltanto in due
- (P)** Executar somente a dois
- (NL)** Met 2 personen uitvoeren
- (DK)** Skal udføres af to personer
- (N)** Må utføres av to personer
- (S)** Utförs endast av två personer
- (SF)** Tehtävä kahdestaan
- (CZ)** Provádût jen ve dvou
- (H)** Csak két személy végezheti el
- (PL)** Wykonywac tylko w dwie osoby
- (GR)** Να εκτελεστεί από δύο άτομα
- (RUS)** ВЫПОЛНЯЙТЕ ВДВОЁМ

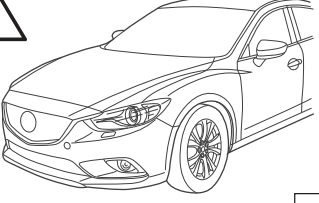
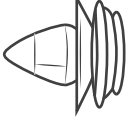
C850-V7-540B

<p>A</p> <p>C850-V7-545</p> <p>A1</p>  <p>2x</p>	<p>B</p> <p>B4</p> <p>B2</p> <p>B1</p> <p>B3</p>  <p>2x</p>	<p>C</p>  <p>1x</p>	
<p>F</p>  <p>4x</p>	<p>G</p>  <p>16x</p>	<p>H</p>  <p>2x</p>	<p>D</p> <p>E</p> <p>2 AMP.</p>  <p>2x</p>  <p>4x</p>
<p>⚠ Separate Purchase ⚠</p>			
<p>⚠</p>  <p>MAZDA CX-5 KF</p>	<p>J</p> <p>⚠ Separate Purchase</p>  <p>2x</p>	<p>K</p> <p>⚠ Separate Purchase</p>  <p>22x</p>	
<p>⚠</p>  <p>MAZDA 6 GJ MAZDA 6 GH JMZGJ *****120400 → → JMZGL *****600000</p>	<p>L</p> <p>⚠ Separate Purchase</p>  <p>18x</p>	<p>M</p> <p>⚠ Separate Purchase</p>  <p>4x</p>	
<p>⚠</p>  <p>MAZDA 6 GH JMZGL *****600001 →</p>	<p>N</p> <p>⚠ Separate Purchase</p>  <p>20x</p>		

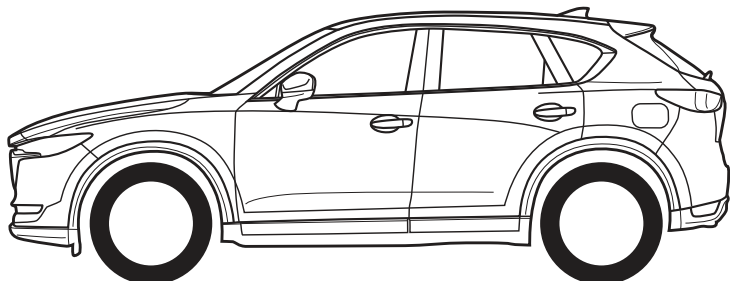
MAZDA CX-5 | KF



MAZDA CX-5 KF	
	Sheet 11-26
	1 - 36

MAZDA 6 GJ

MAZDA 6 GH

JMZGJ *****120400 →

JMZGL *****500015 →

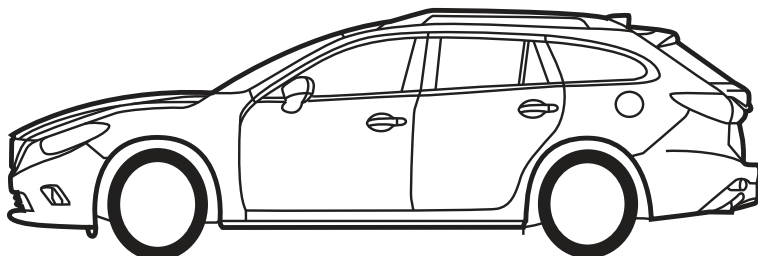
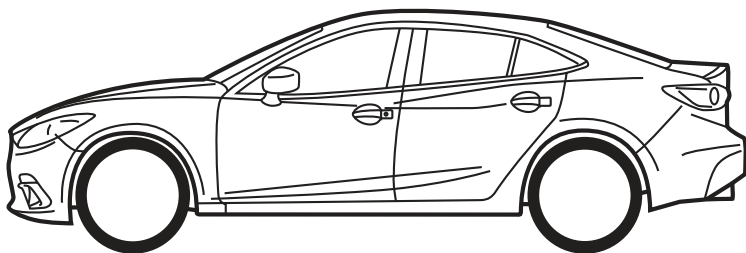

MAZDA 6 GJ/GH SEDAN & WAGON	
	Sheet 27-50
	37 - 75

! info C850-V7-540B

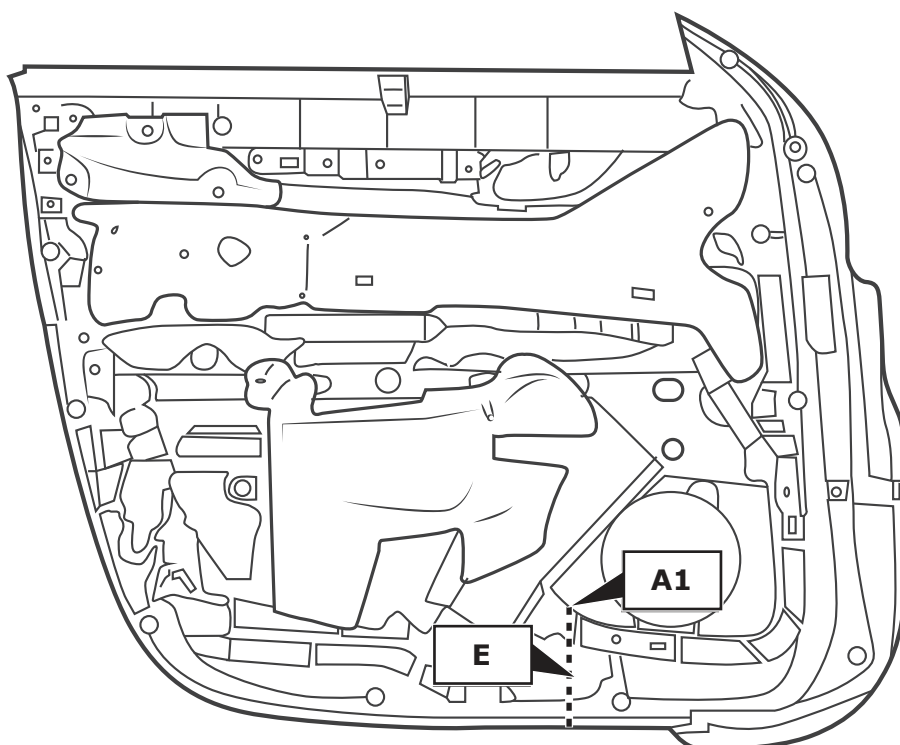
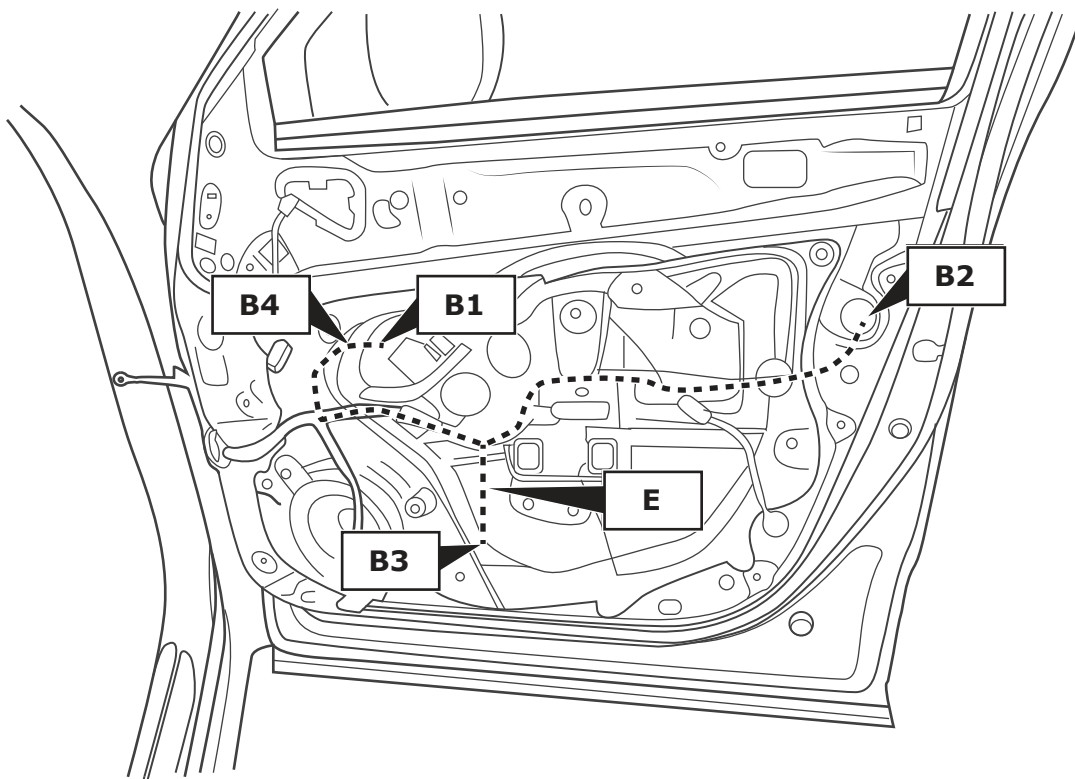

MAZDA CX-5 KF

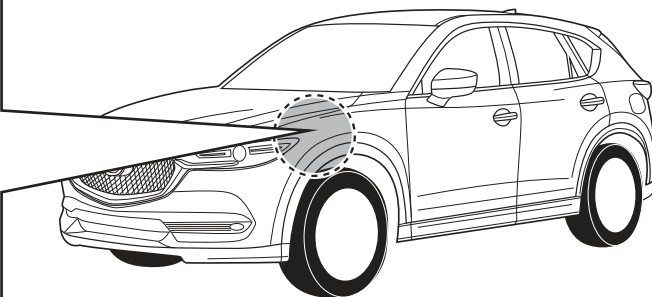
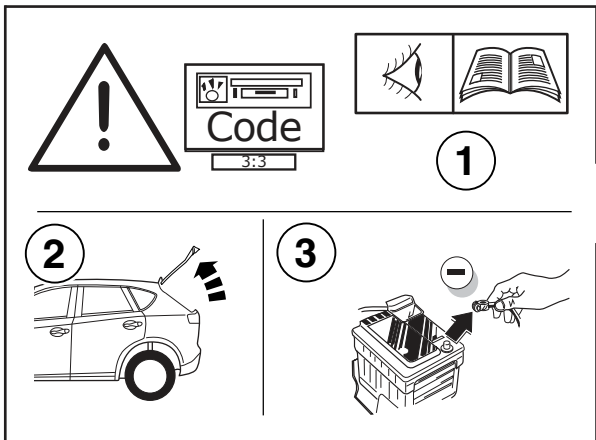

1

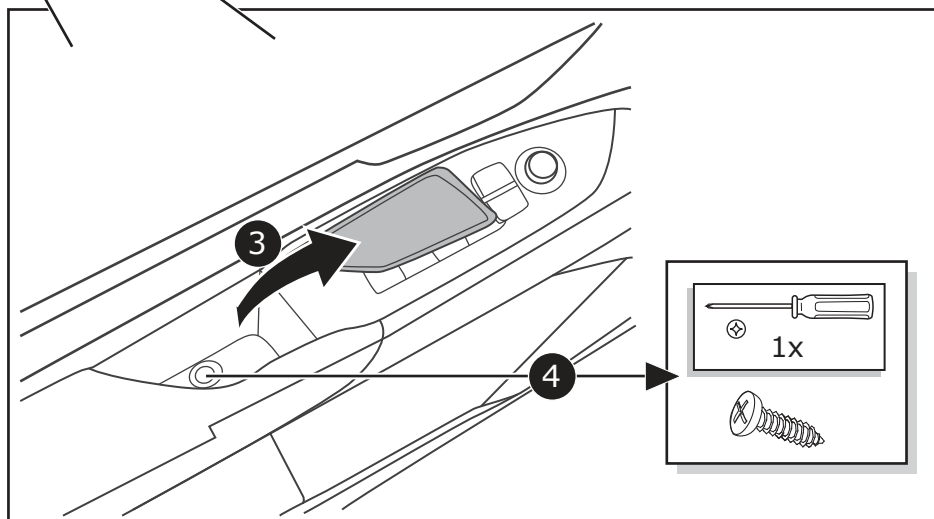
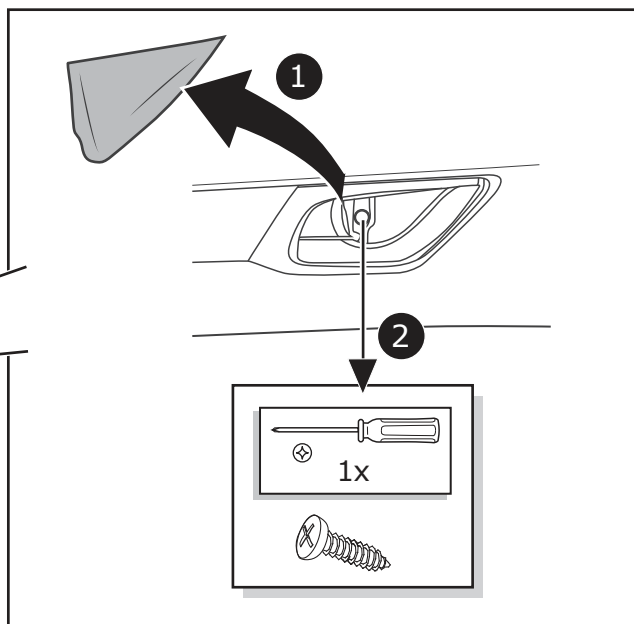
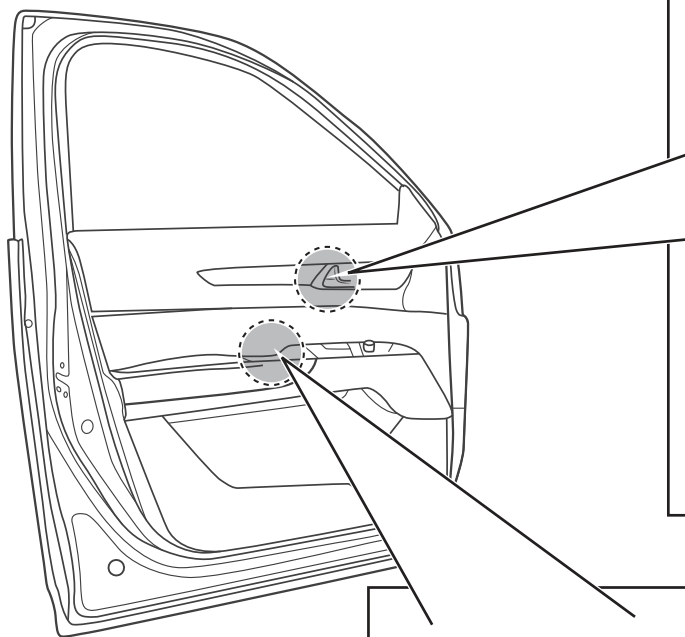

2



	 1x
	 1x
	 11x

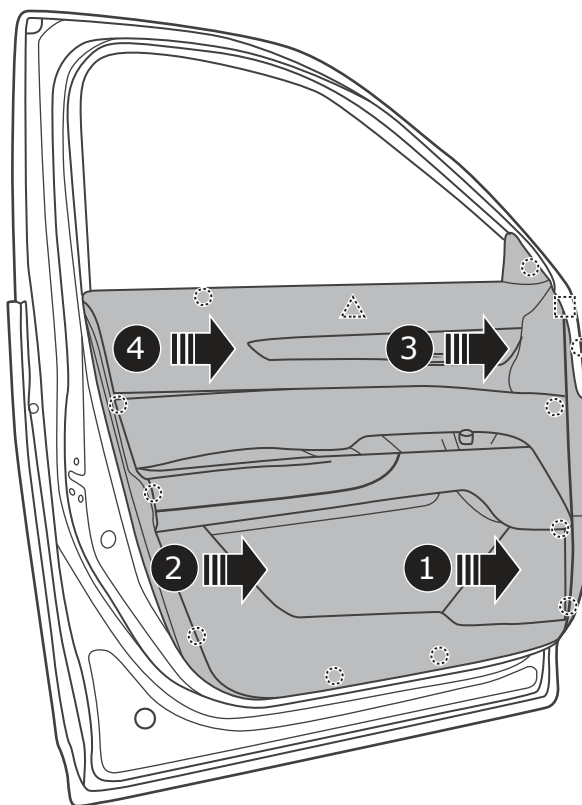

3

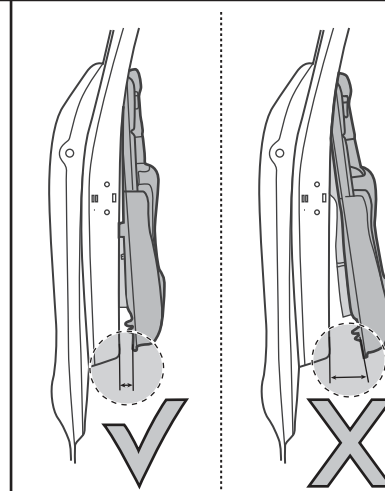
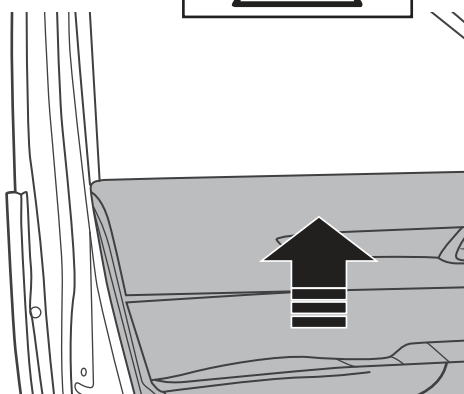

4

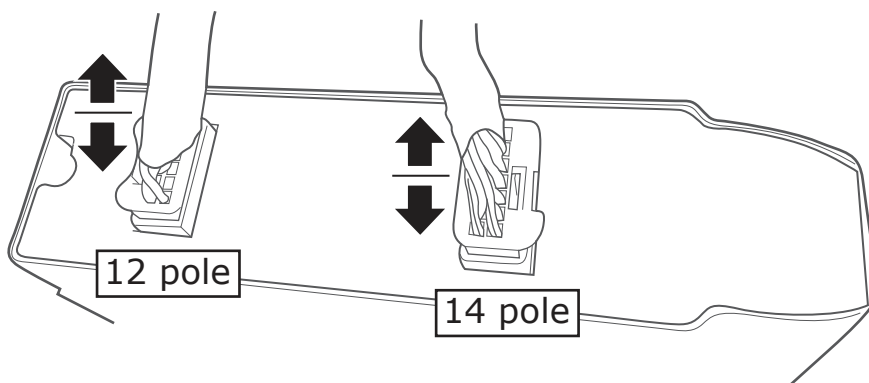
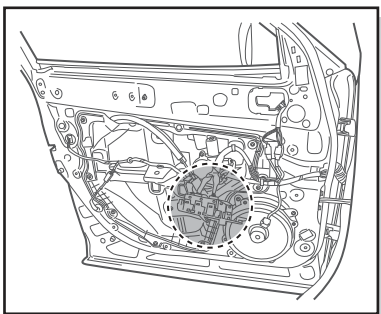

5

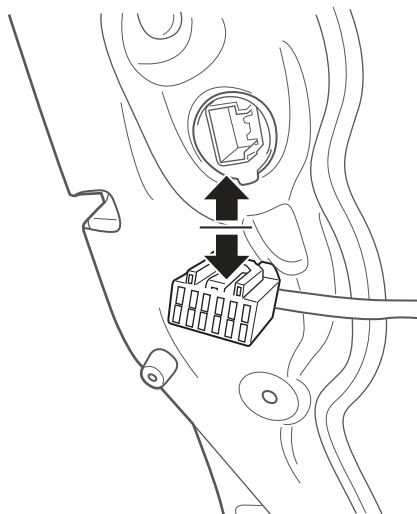
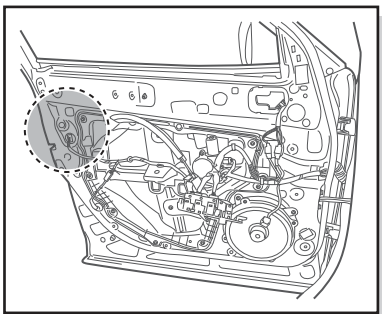
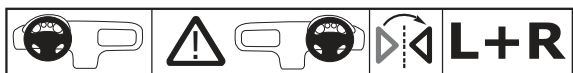

6

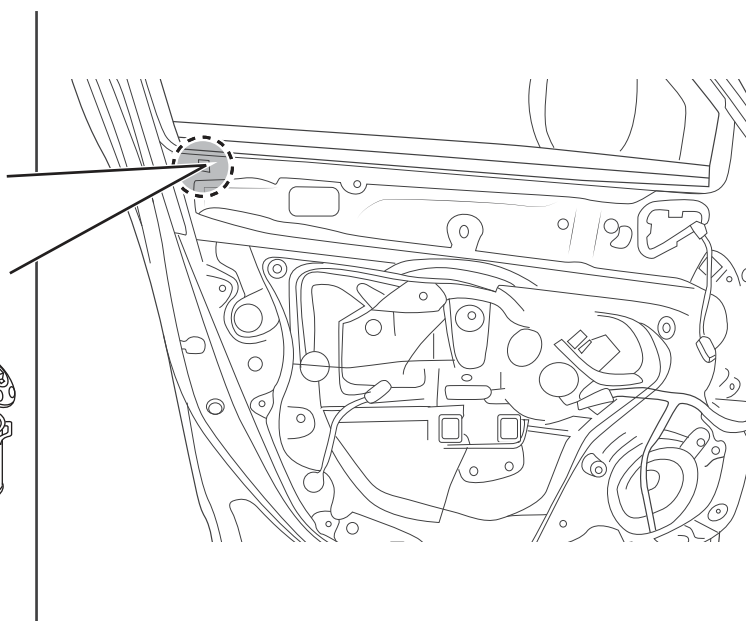
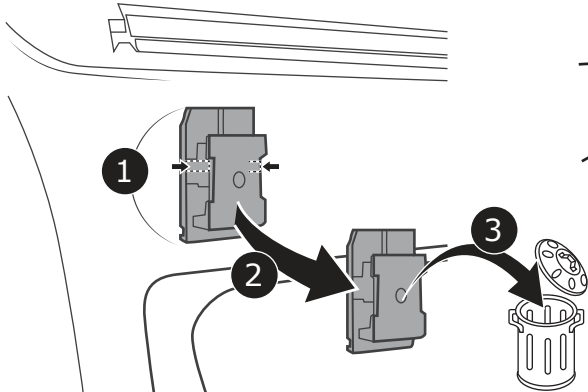

7

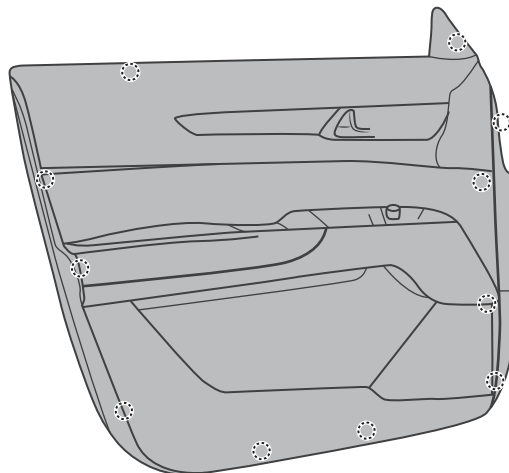
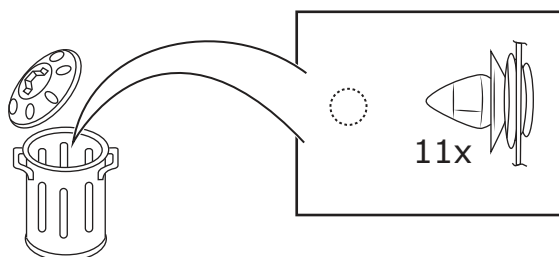

8

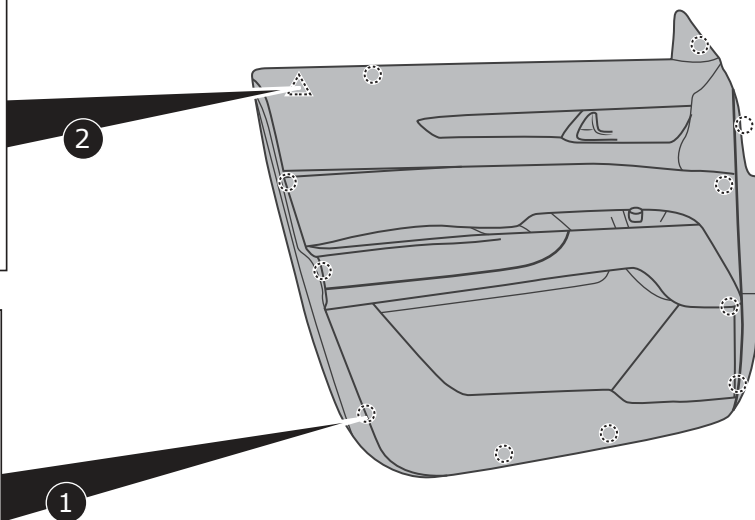
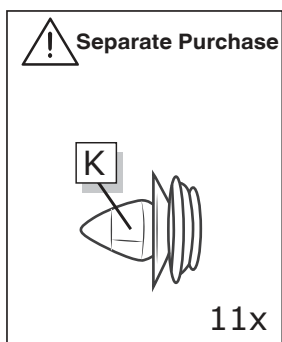
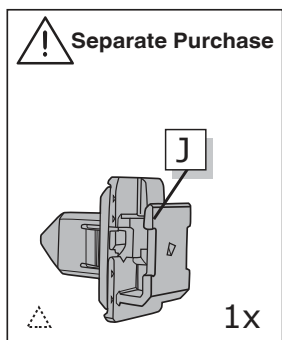

9

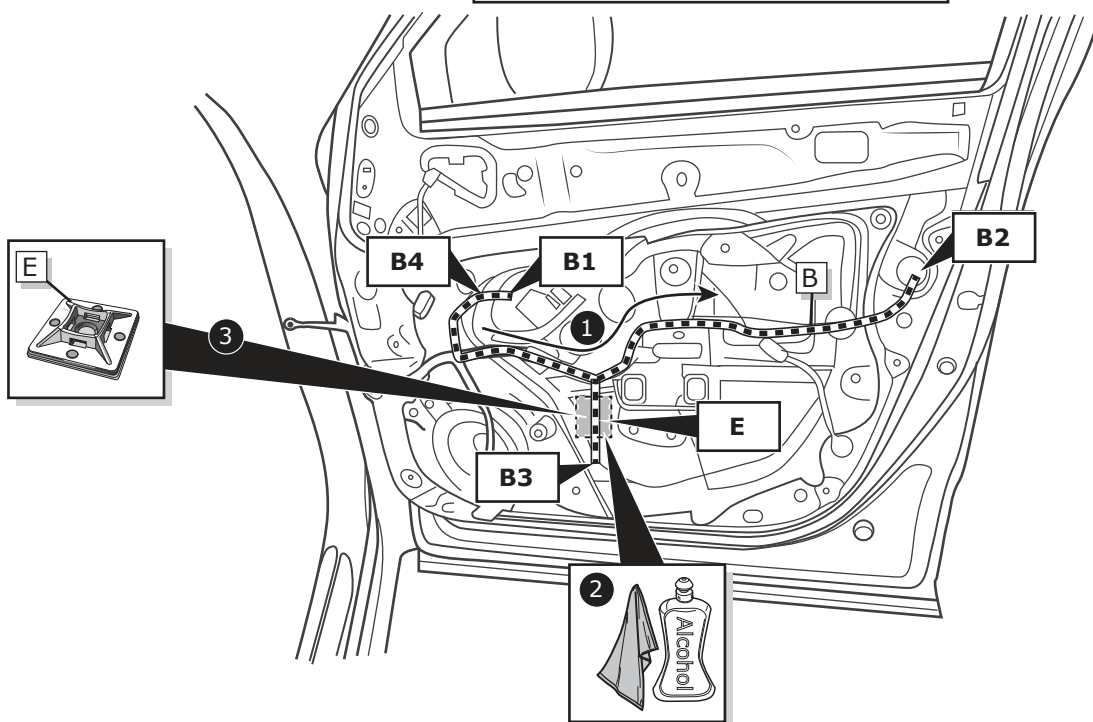
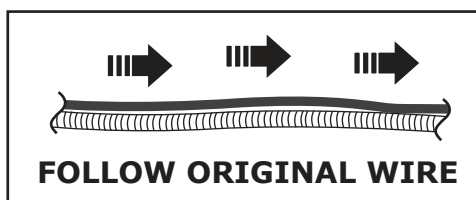

10

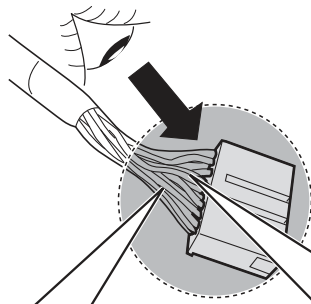
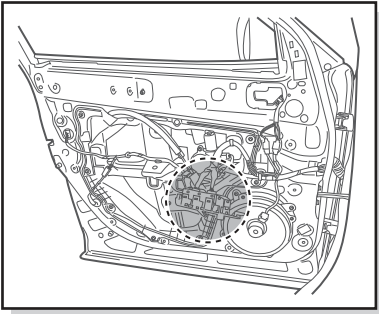
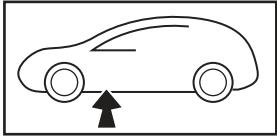

0912-301A
POWER WINDOW MAIN SWITCH/
POWER OUTER MIRROR SWITCH

1K	1I	1G	1E	1C	1A
1L	1J	1H	1F	1D	1R

12 pole Y

0912-201A
POWER WINDOW MAIN SWITCH/
POWER OUTER MIRROR SWITCH
DOOR LOCK SWITCH (LH)

1K	1I	1G	1E	1C	1A
1L	1J	1H	1F	1D	1B

12 pole Y

-
-
-

11

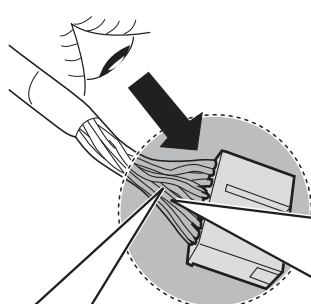
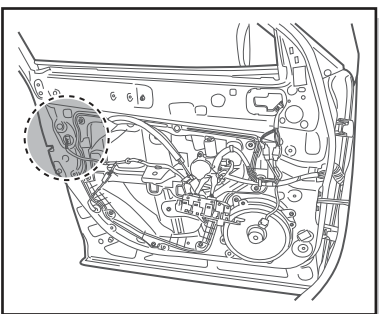
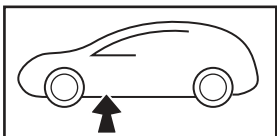

0914-102
FRONT DOOR LATCH AND LOCK
ACTUATOR (LH)

K	I	G	E	C	A
L	J	H	F	D	B

G 12 pole

0914-211
FRONT DOOR LATCH AND LOCK
ACTUATOR (LH)

K	I	G	E	C	A
L	J	H	F	D	B

G 12 pole

-
-
-

12

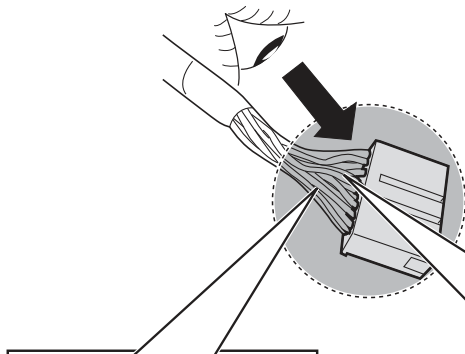
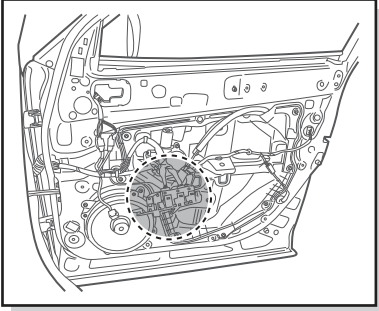
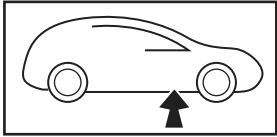

0912-303
POWER WINDOW SUBSWITCH (RF)

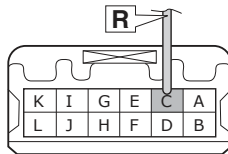

12 pole

0912-203
POWER WINDOW SUBSWITCH (RF)

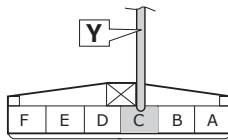

6 pole

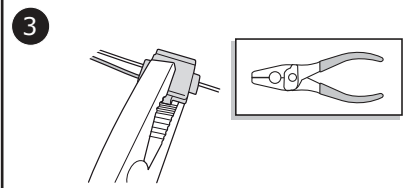
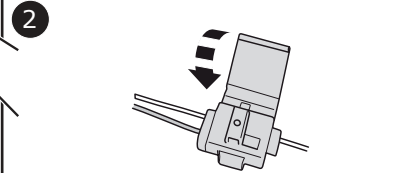
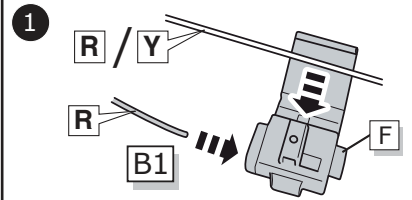

13

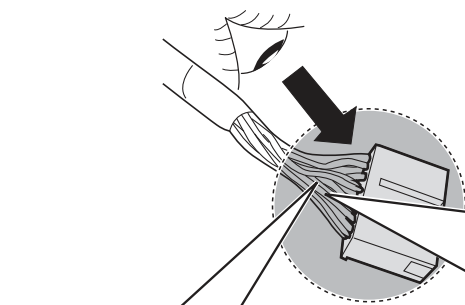
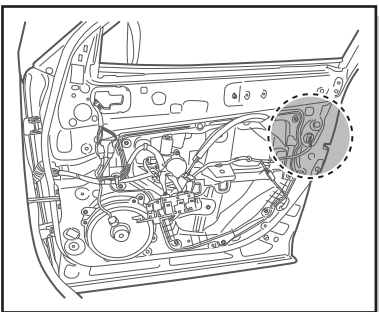
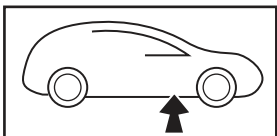

0914-103
FRONT DOOR LATCH AND LOCK ACTUATOR (RH)



12 pole

0914-212
FRONT DOOR LATCH AND LOCK ACTUATOR (RH)



12 pole

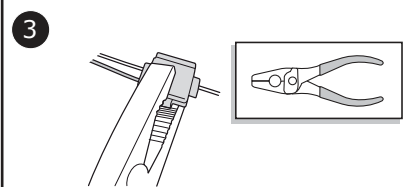
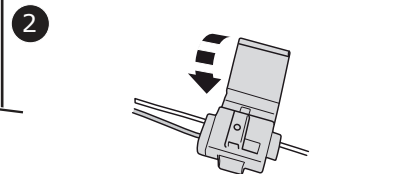
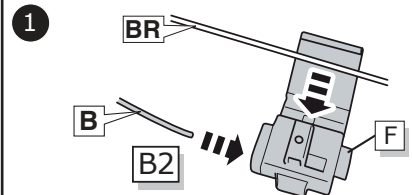

14

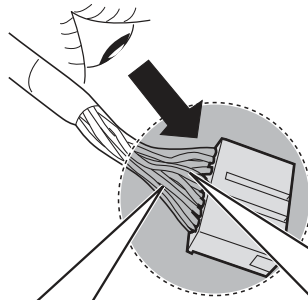
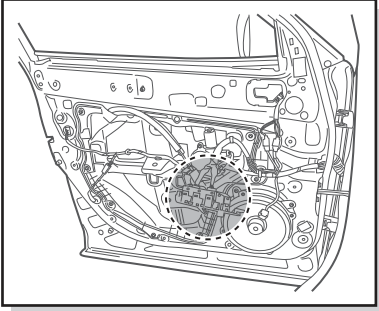
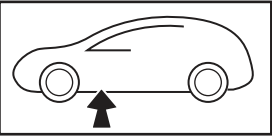
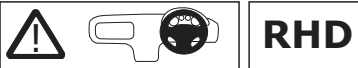

0912-303
POWER WINDOW SUBSWITCH (LF)

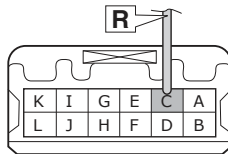

12 pole

0912-203
POWER WINDOW SUBSWITCH (LF)

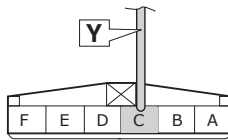

6 pole

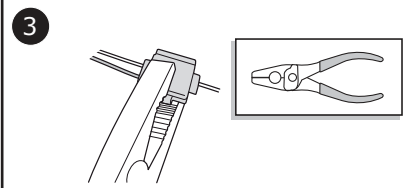
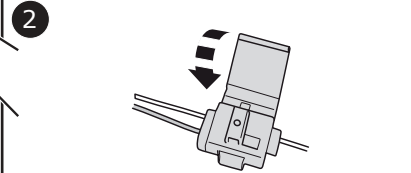
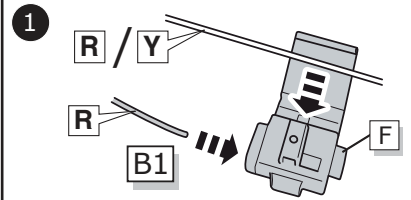

15

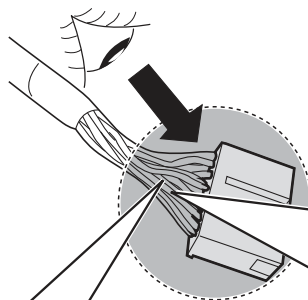
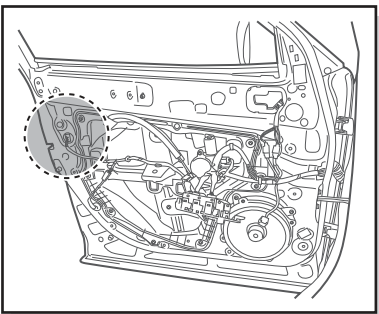
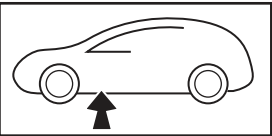

0914-102
FRONT DOOR LATCH AND LOCK ACTUATOR (LH)

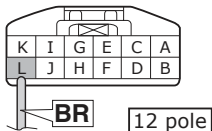

12 pole

0914-211
FRONT DOOR LATCH AND LOCK ACTUATOR (LH)

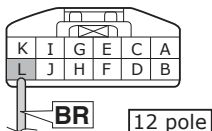

12 pole

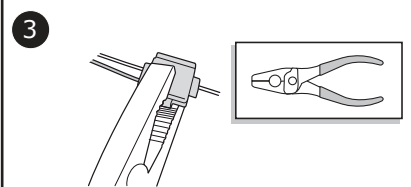
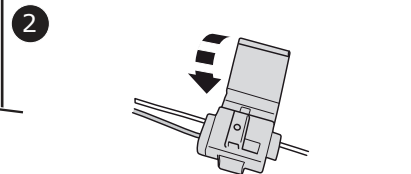
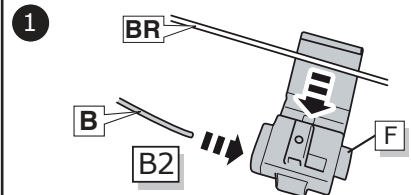

16

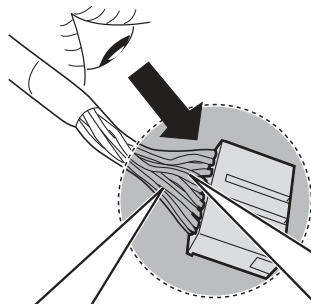
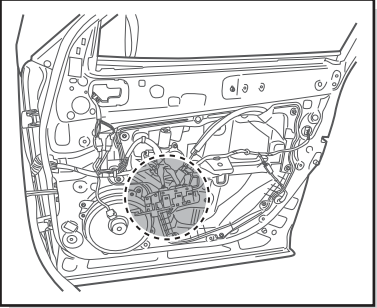
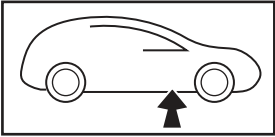

0912-201A
POWER WINDOW MAIN SWITCH/
POWER OUTER MIRROR SWITCH
DOOR LOCK SWITCH (RH)

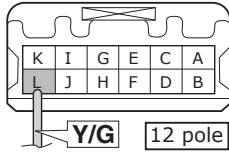

0912-301A
POWER WINDOW MAIN SWITCH/
POWER OUTER MIRROR SWITCH

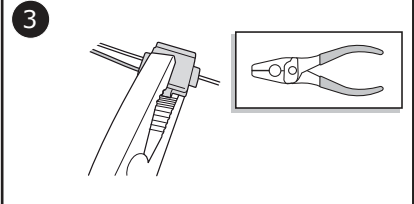
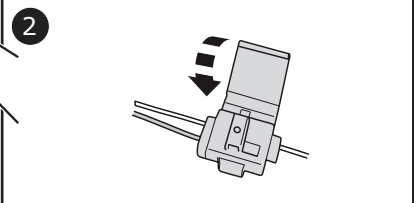
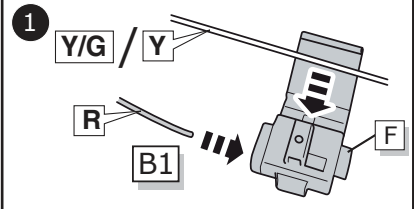
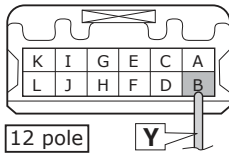

17

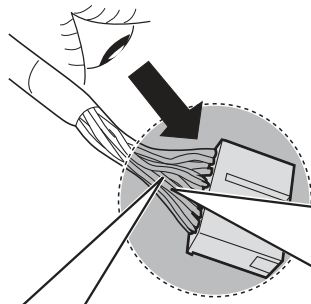
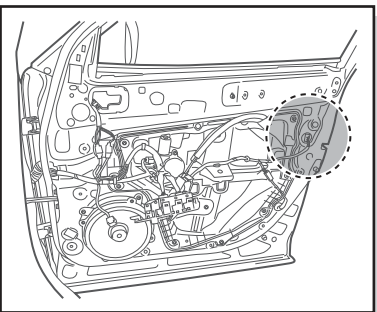
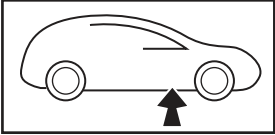

0914-103
FRONT DOOR LATCH AND LOCK
ACTUATOR (RH)

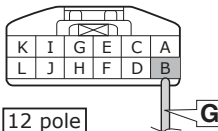

0914-212
FRONT DOOR LATCH AND LOCK
ACTUATOR (RH)

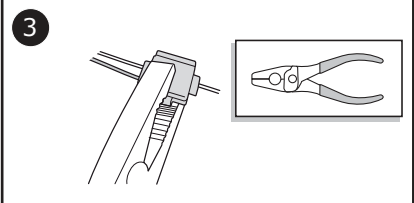
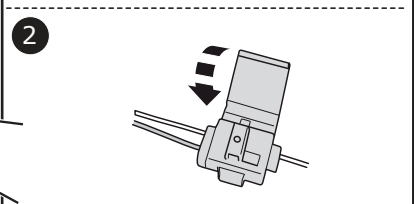
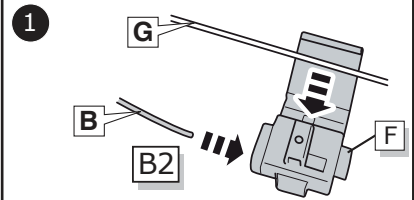
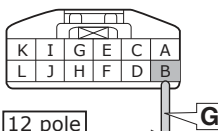

18

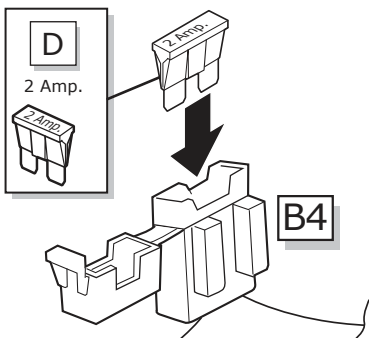

D
2 Amp.

B4

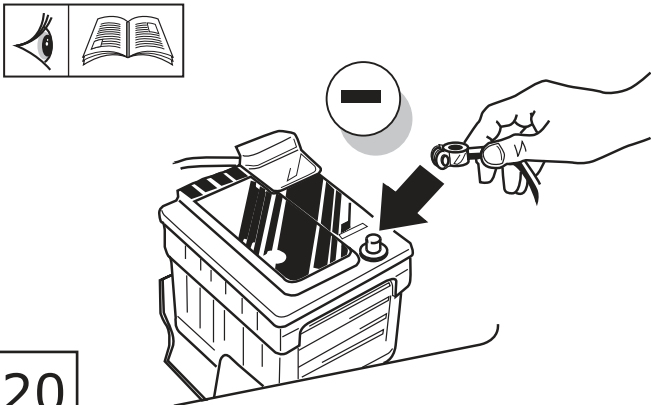

19
2x
20

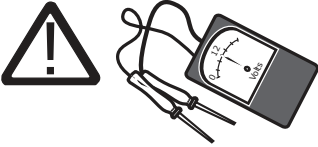

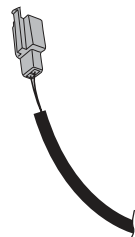

B3

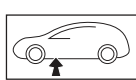
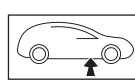
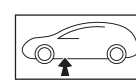
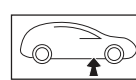
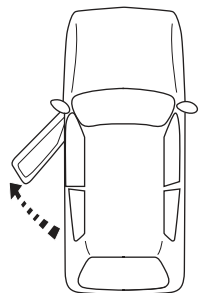
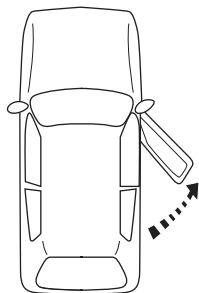
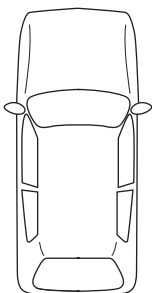
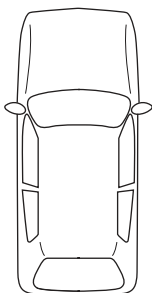

				
				
12 Volt				
0 Volt				

21





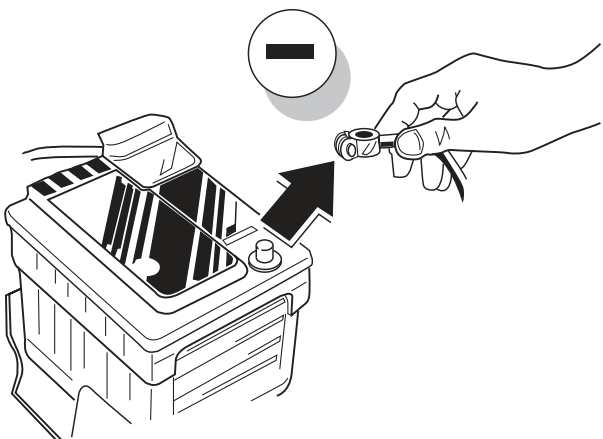

22

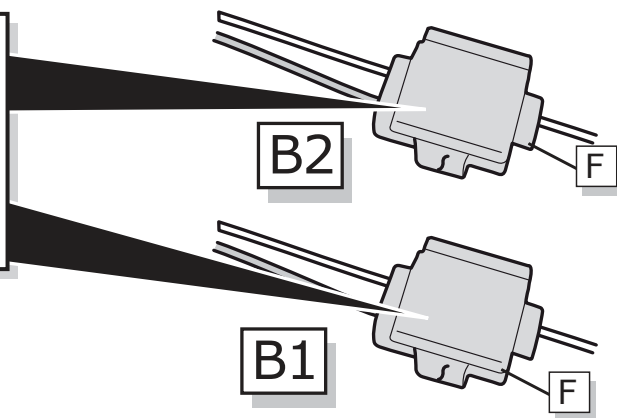
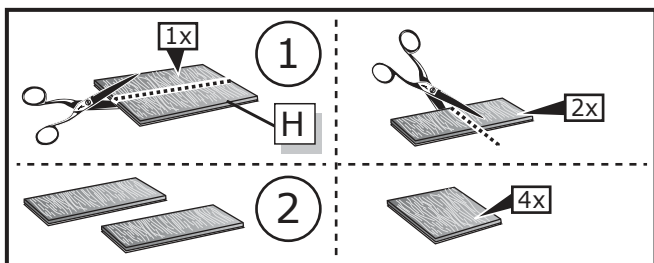
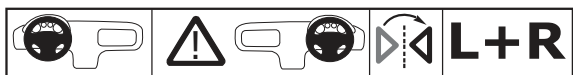

23

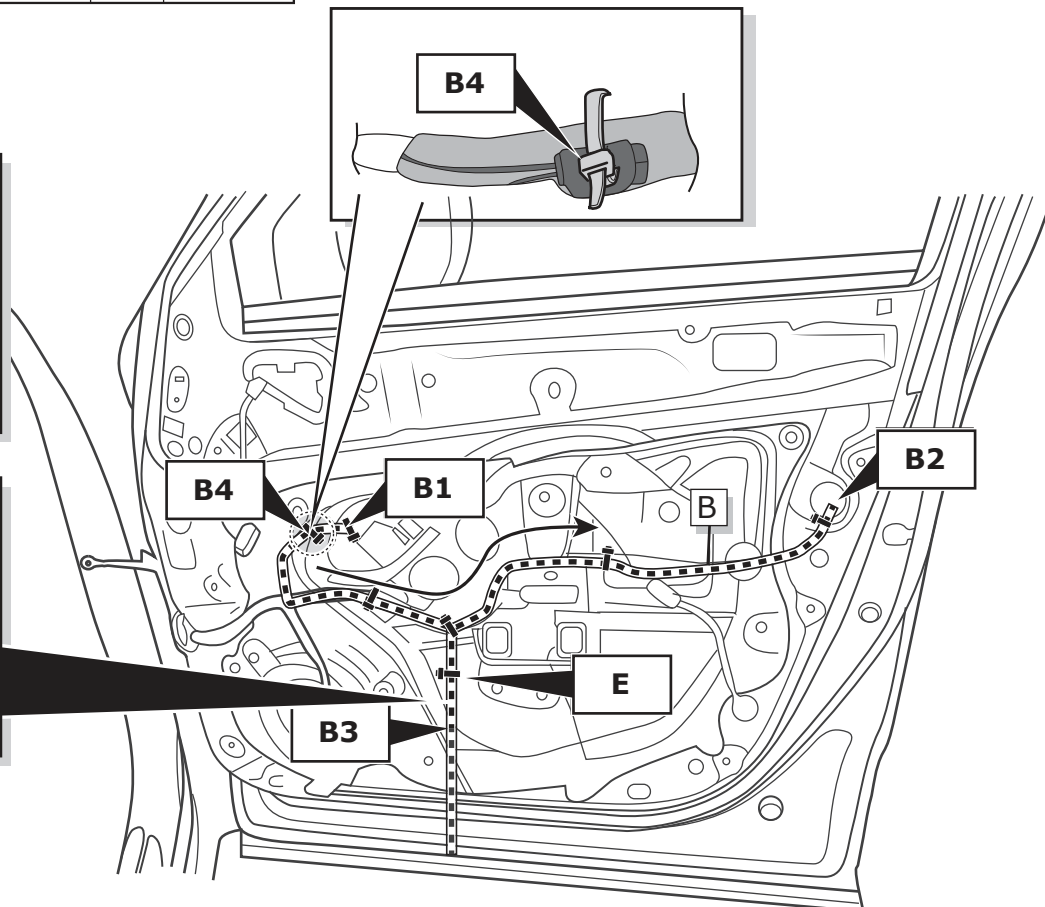
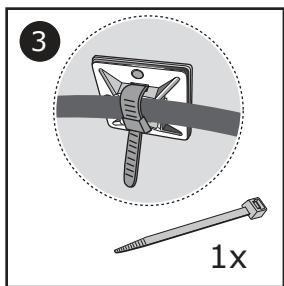
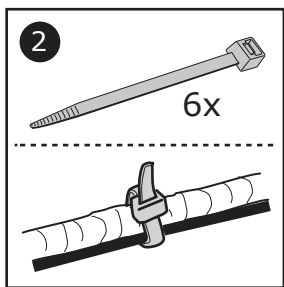

24

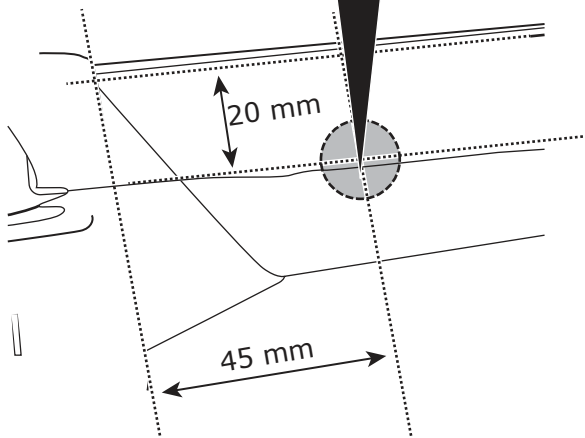
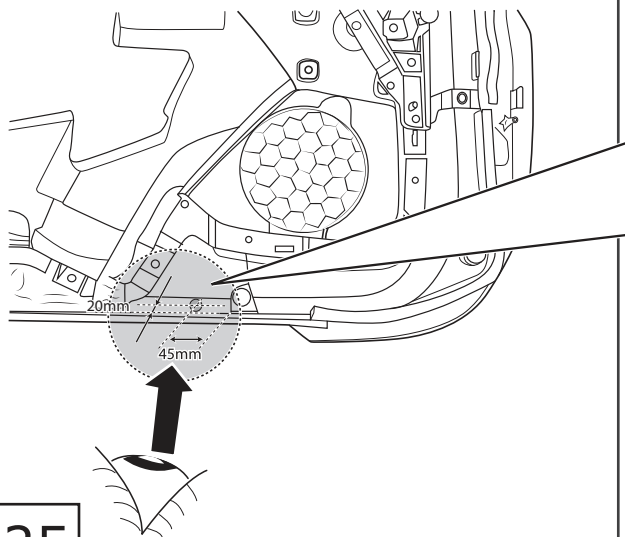
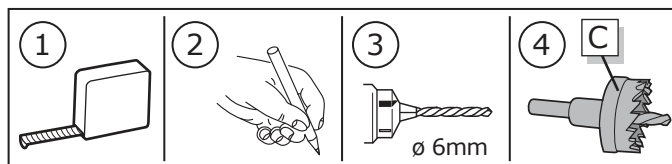
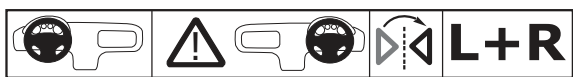

25

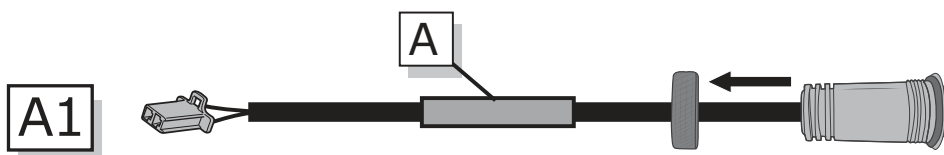

26

2x

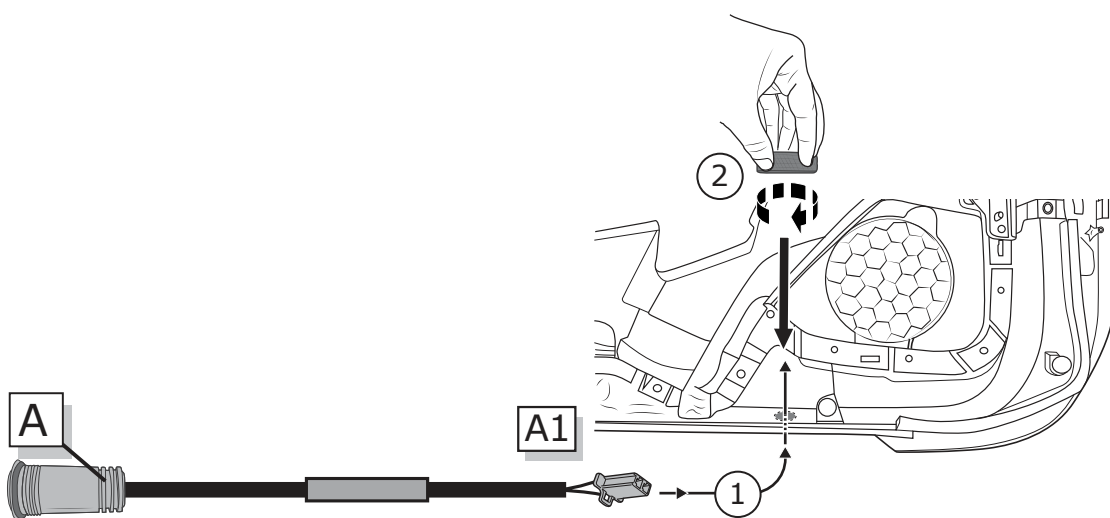
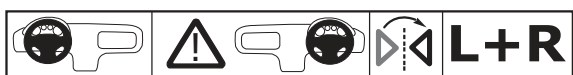

27

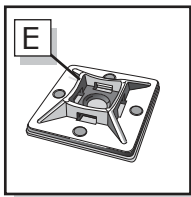
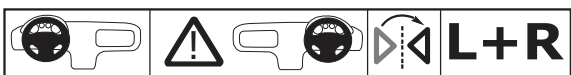

2

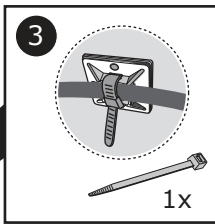
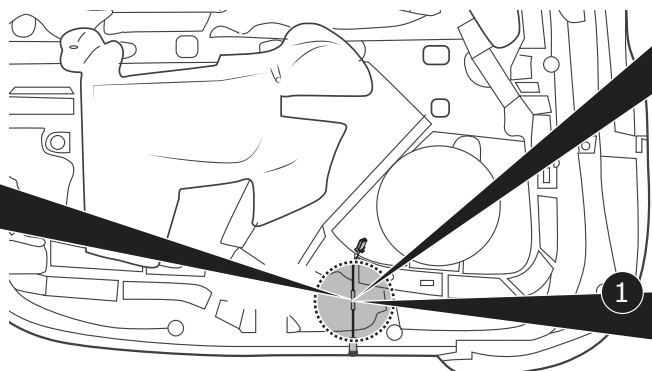

28

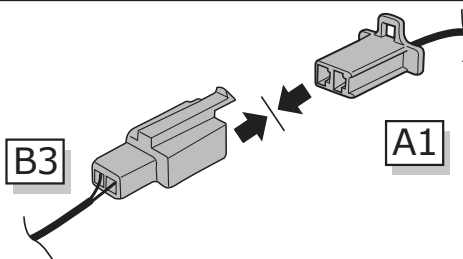
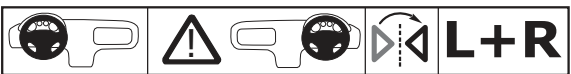

29

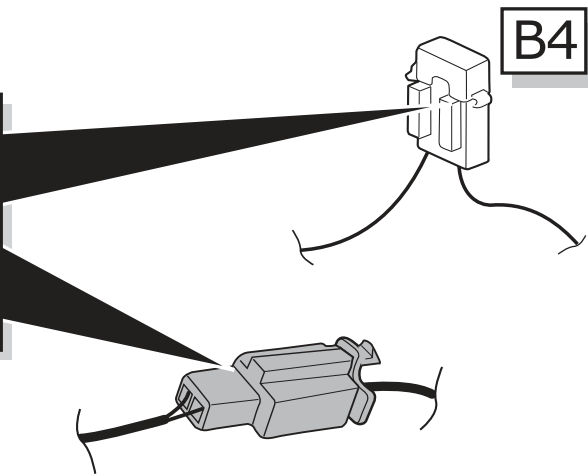
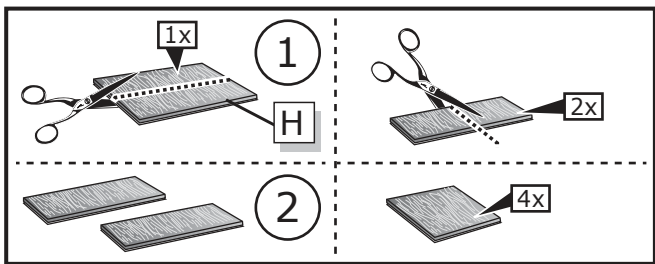

30

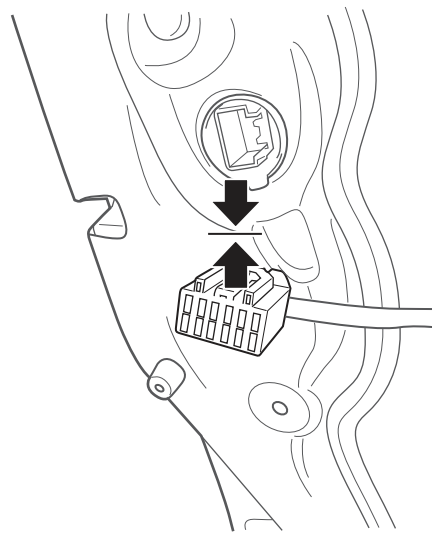
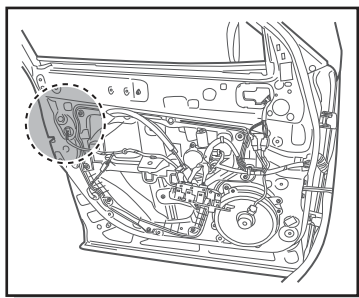

31

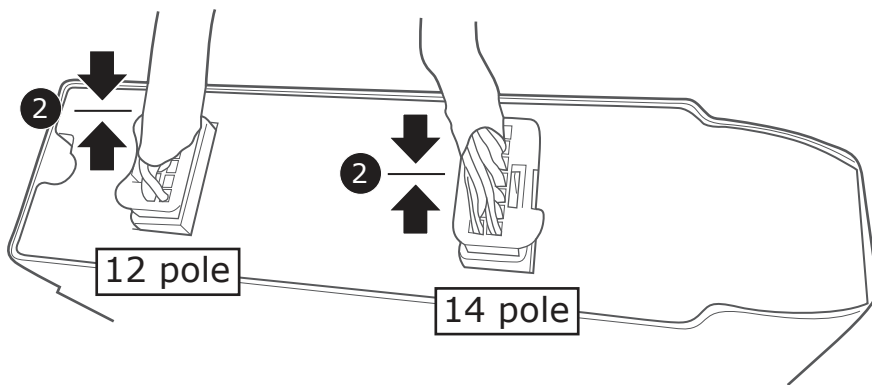
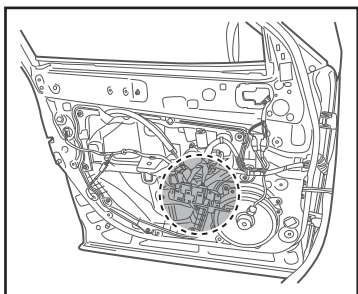
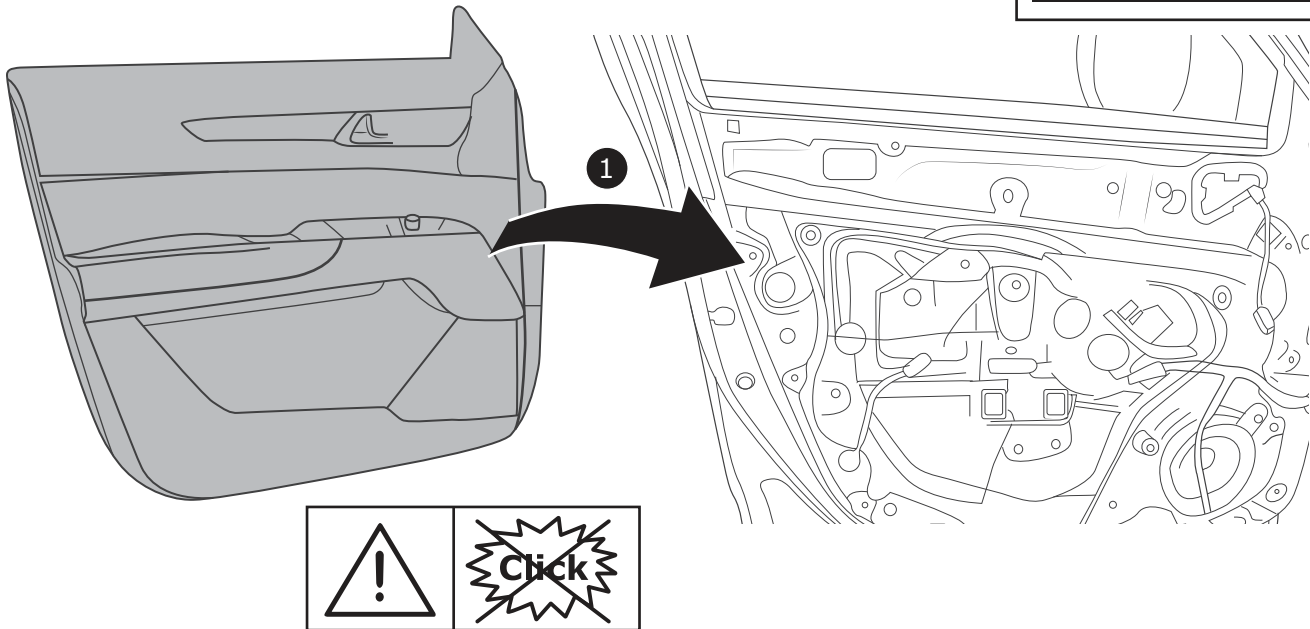
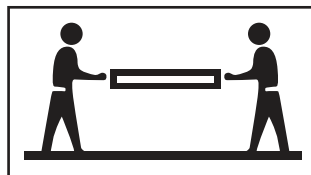

32

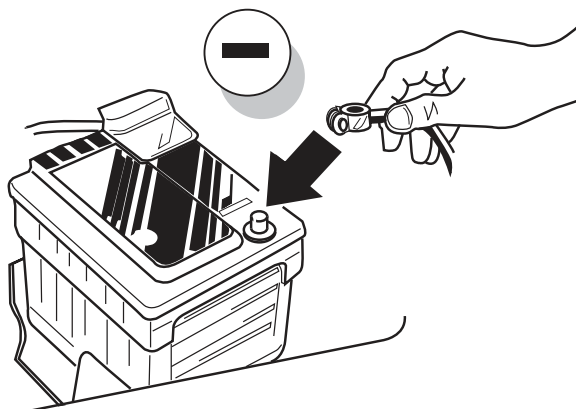

33

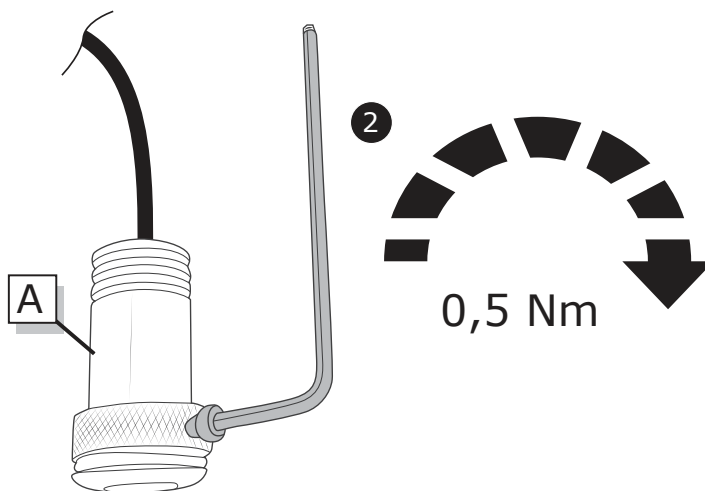
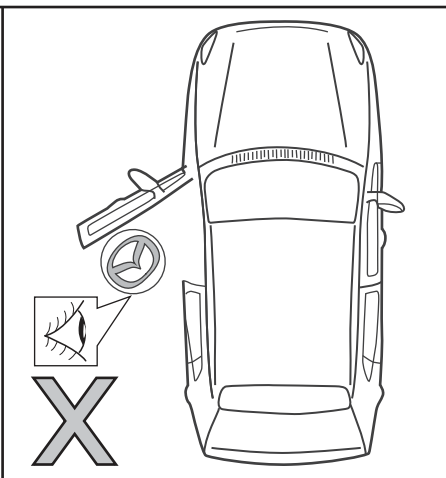
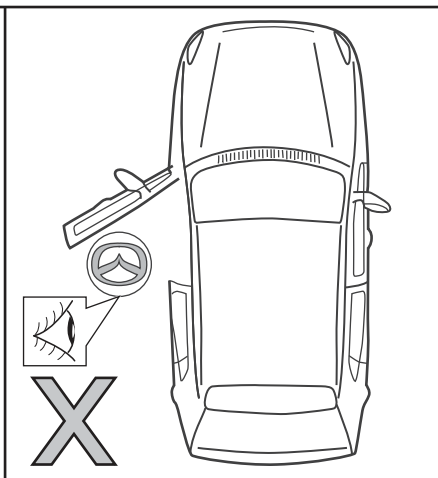
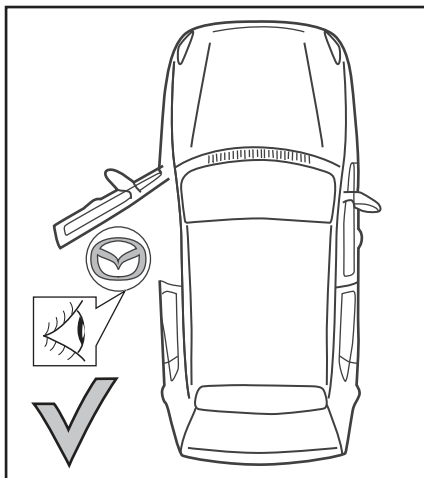
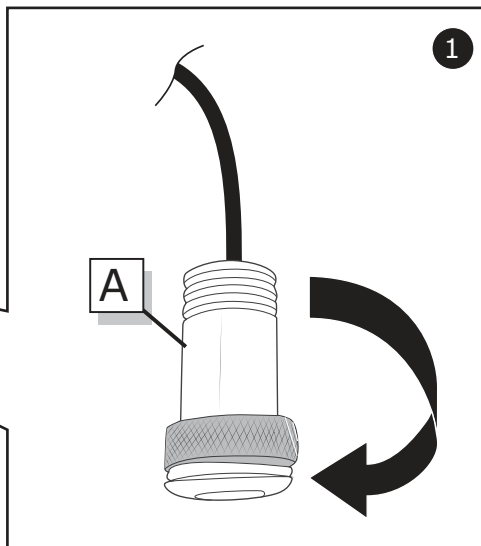
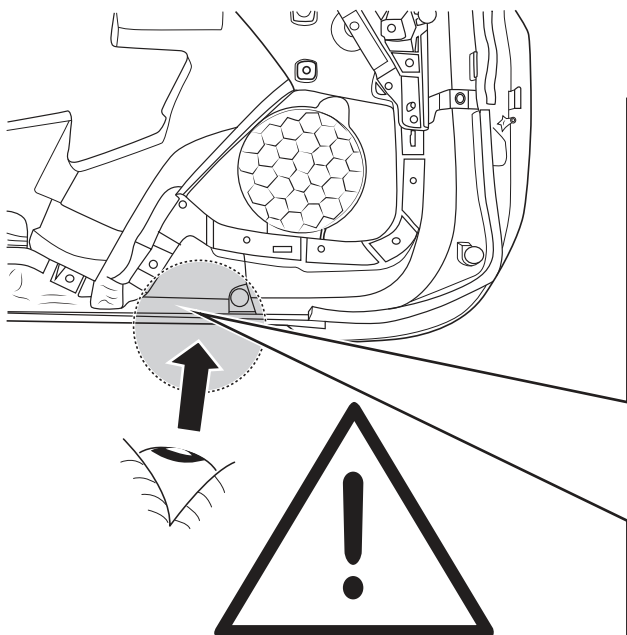
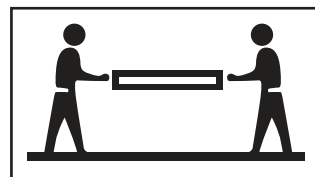
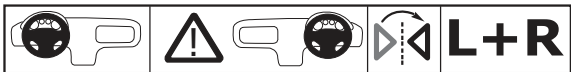



Click

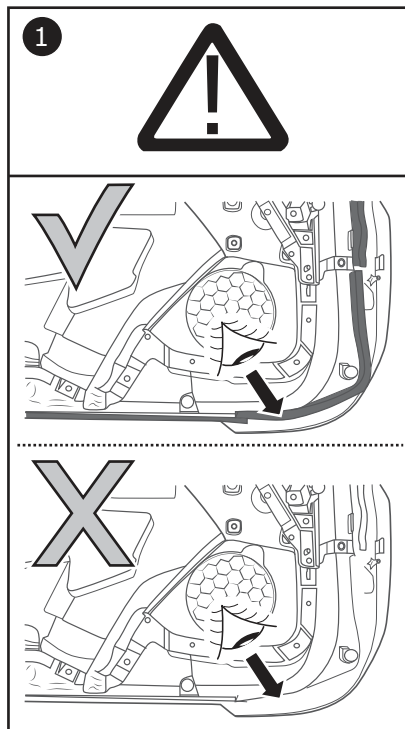
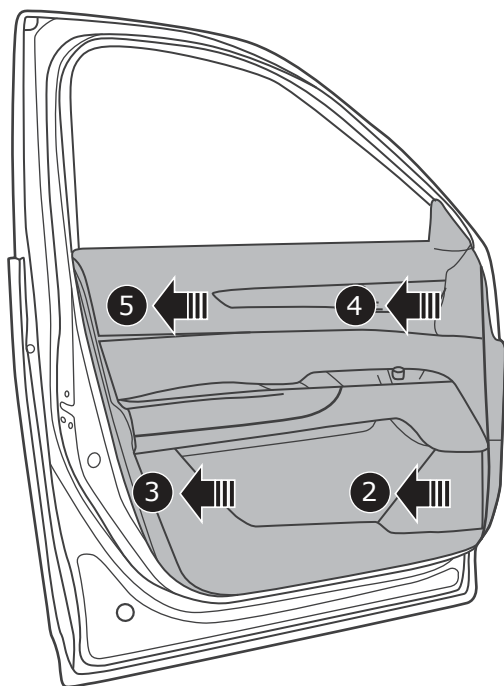

35

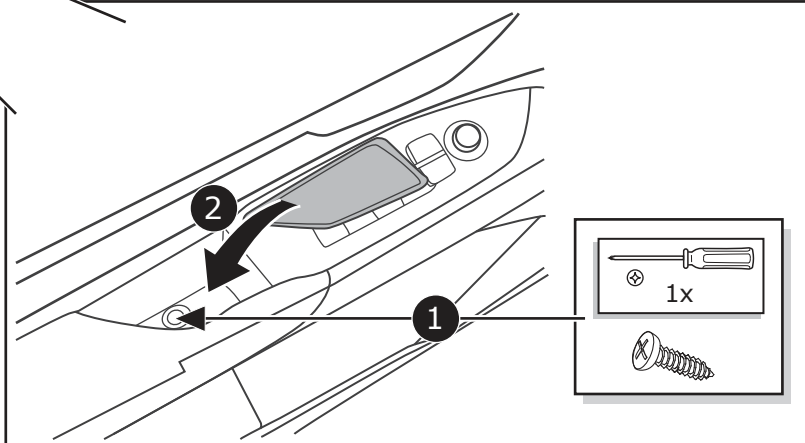
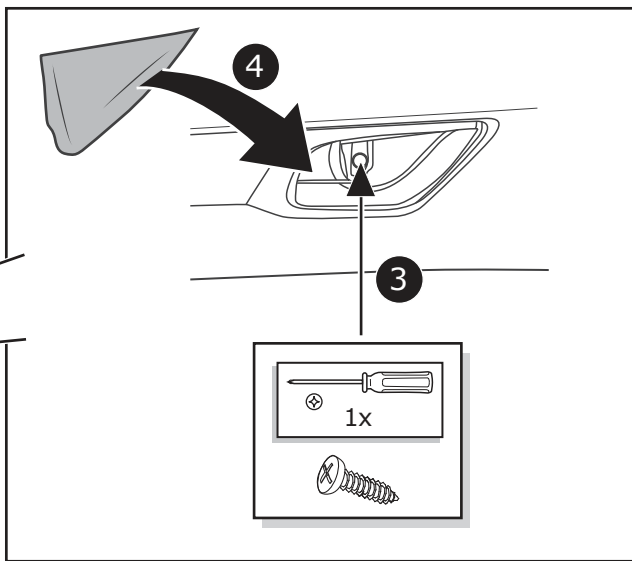
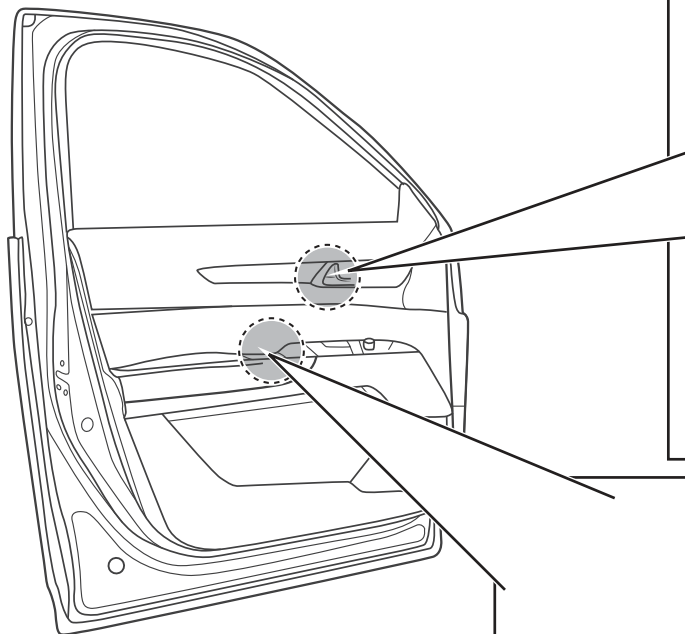

36

Subject to alteration without notice
Technische Änderungen vorbehalten
Reservadas modificaciones técnicas
Sous réserve de modifications techniques
Con riserva di apportare modifiche tecniche
Reservamo-nos o direito a alterações técnicas
Technische wijzigingen voorbehouden
Med forbehold for tekniske índringer
Tekniske forendringer forbeholdes
Med reservation för tekniska ändringar
Tekniset muutokset pidätetään
Technické zmeny vyhrazeny
A változtatások technika jogát fenntartjuk
Zmiany techniczne zastrzeżone
Επιφυλασσόμεθα για αλλαγές

!	MAZDA 6 GJ
	MAZDA 6 GH
	JMZGJ *****120400 →
	JMZGL *****500015 →

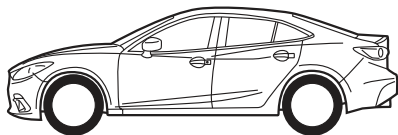

!	 Code <small>3:3</small>	 1
	2 	3

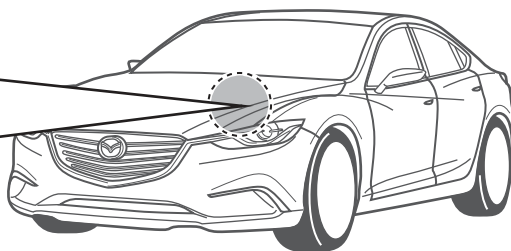

!	MAZDA 6 GJ
	MAZDA 6 GH
	JMZGJ *****120400 →
	JMZGL *****500015 →

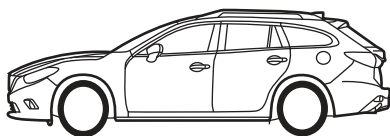

!	 Code <small>3:3</small>	 1
	2 	3

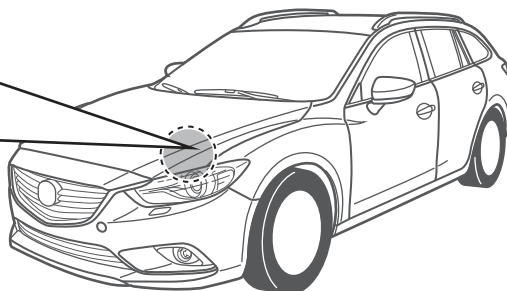



MAZDA 6 GJ
MAZDA 6 GH
JMZGJ *****120400 →
→ JMZGL *****600000

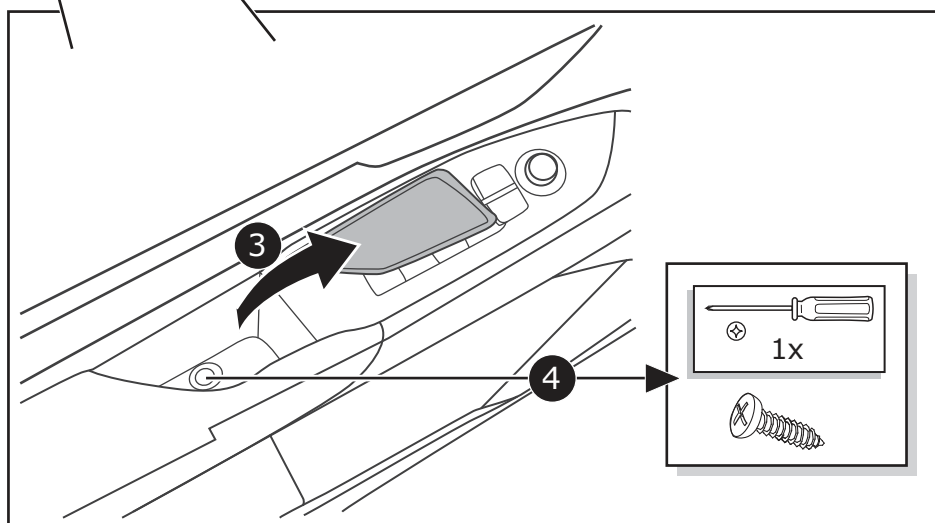
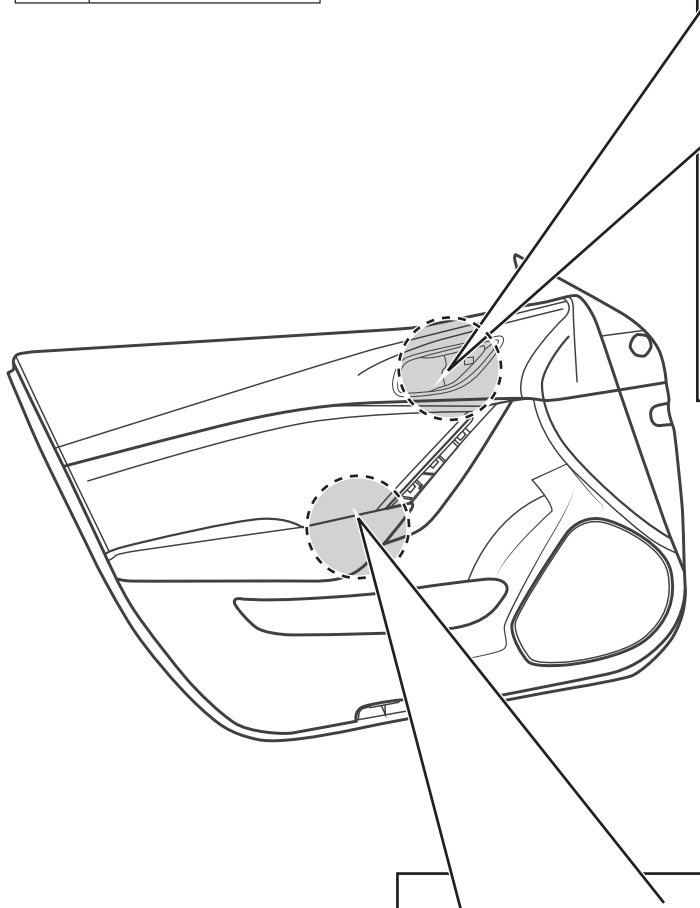
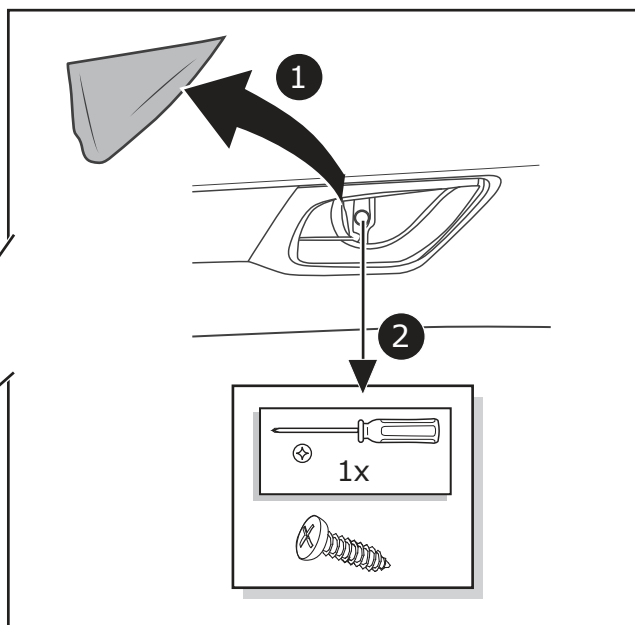





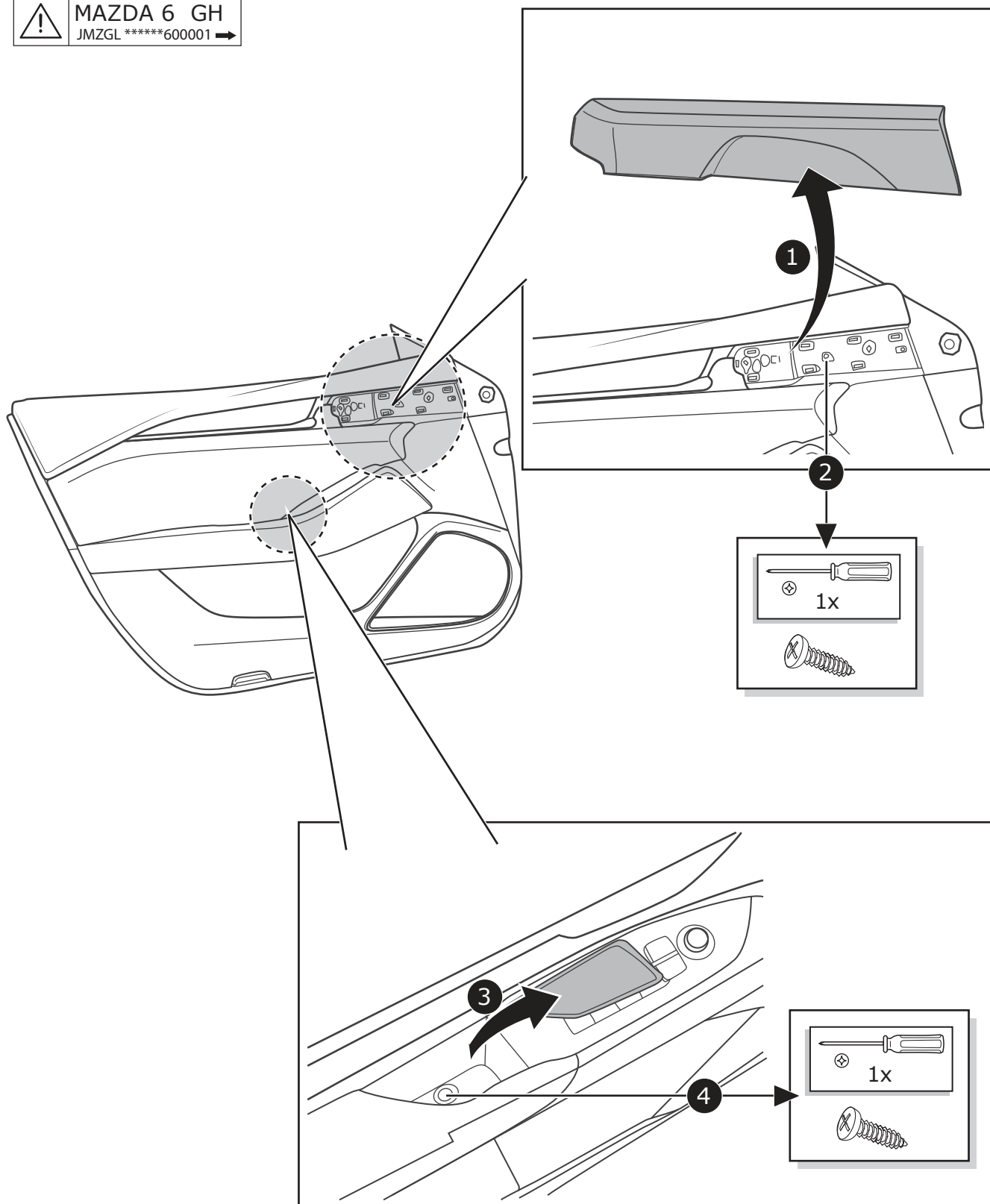

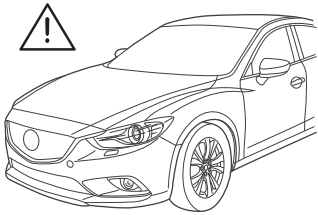



MAZDA 6 GH
JMZGL *****600001 →







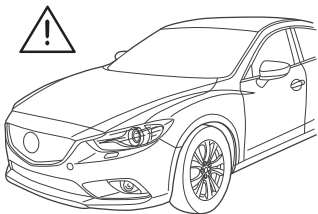
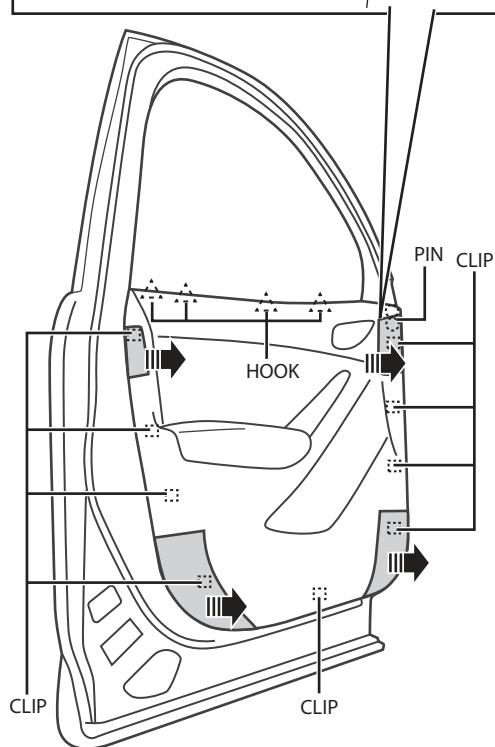
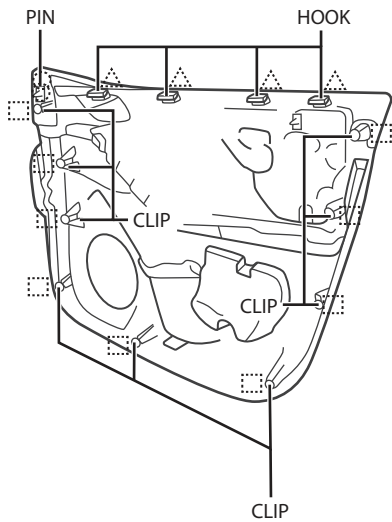
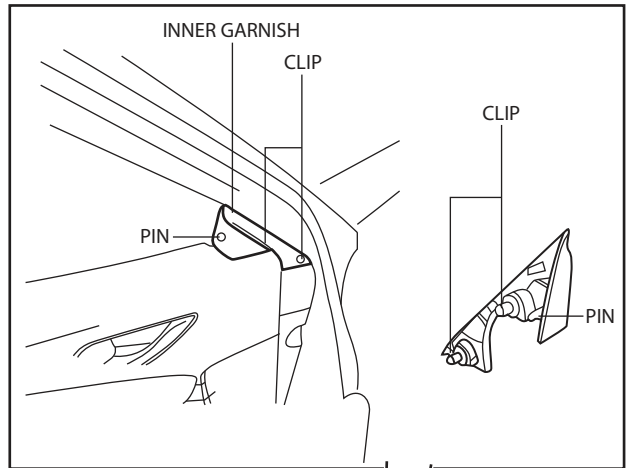

MAZDA 6 GJ
MAZDA 6 GH
 JMZGJ *****120400 →
 → JMZGL *****600000

	
	2X 
	4X 
	9X 



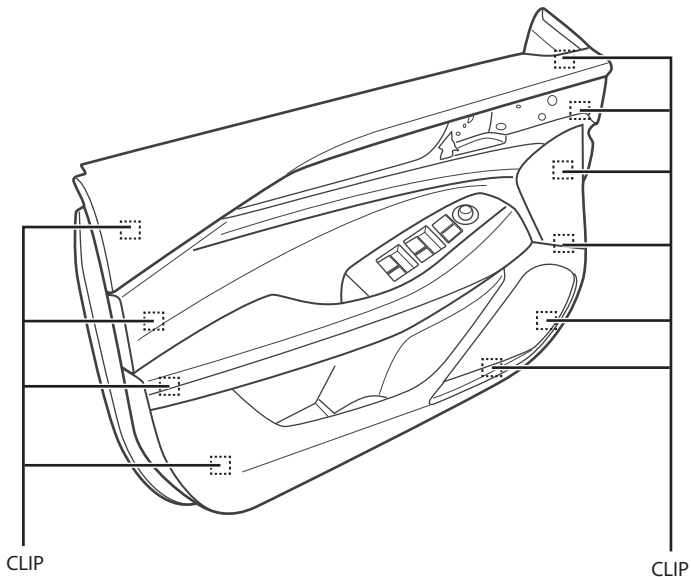

MAZDA 6 GH
 JMZGL *****600001 →

	
	10X 

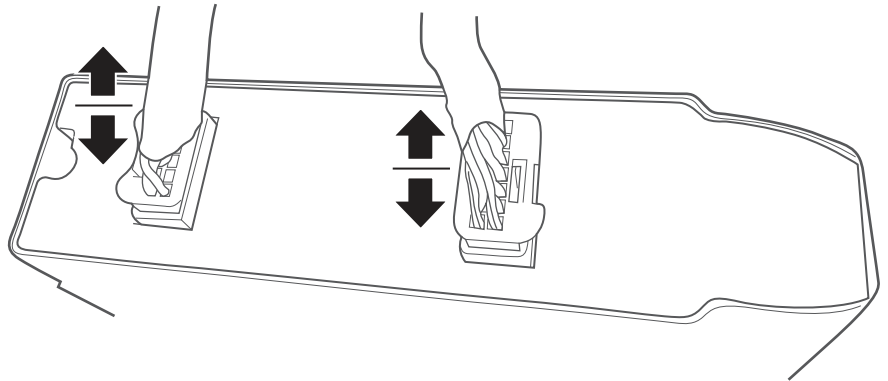
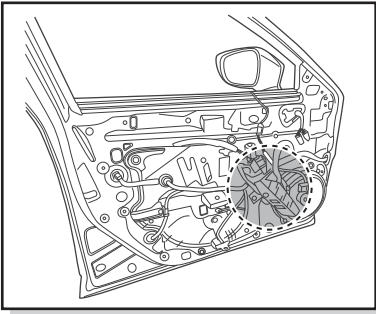



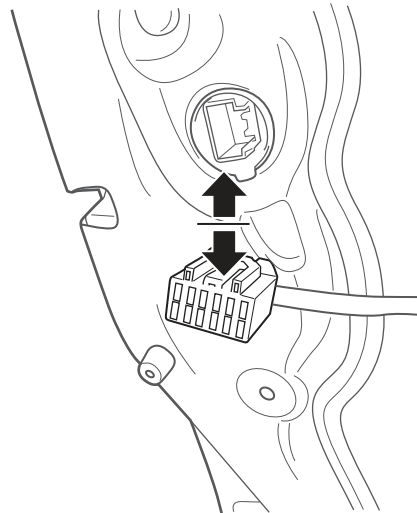
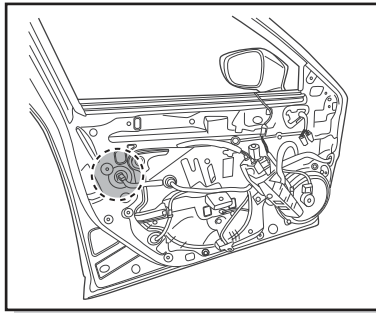
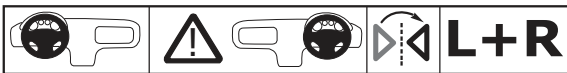

41

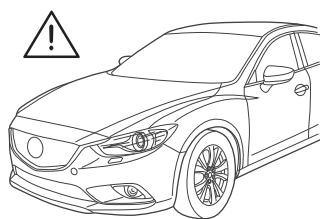

42

Door Lock System



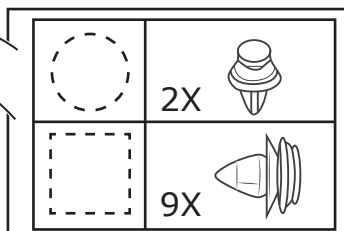
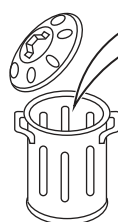
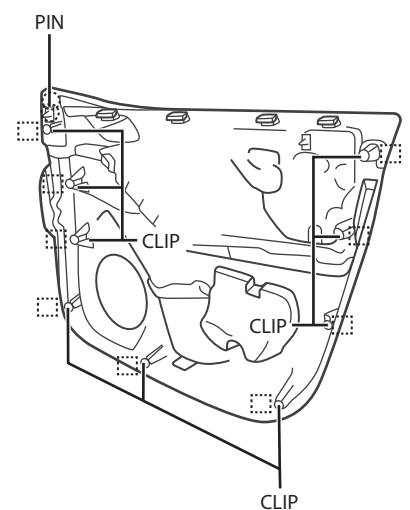
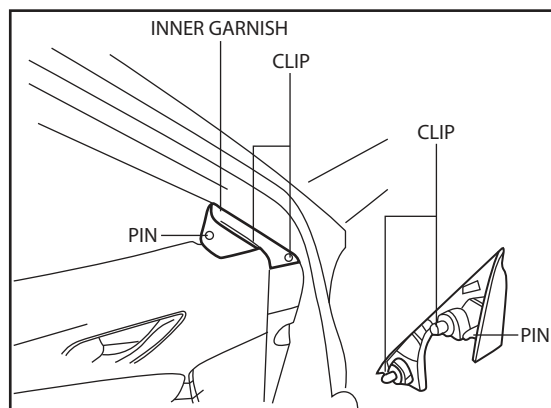

MAZDA 6 GJ
MAZDA 6 GH
 JMZGJ *****120400 →
 → JMZGL *****600000

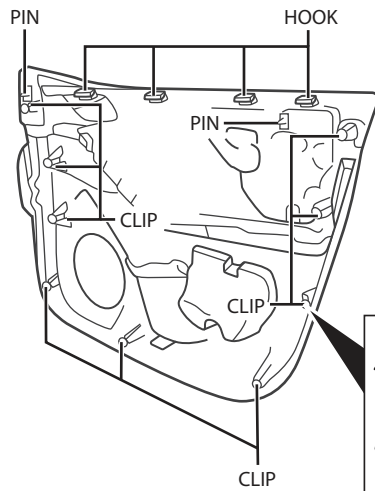
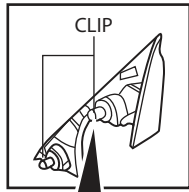
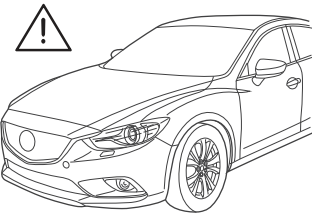

43

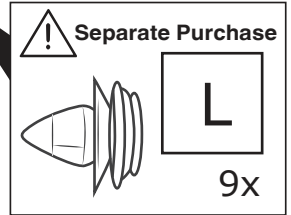
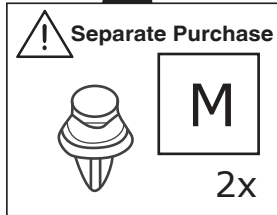

MAZDA 6 GJ
MAZDA 6 GH
 JMZGJ *****120400 →
 → JMZGL *****600000



44

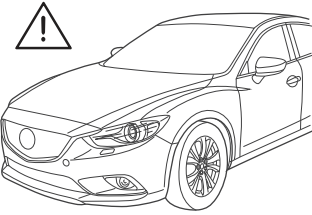

MAZDA 6 GH
 JMZGL *****600001 →

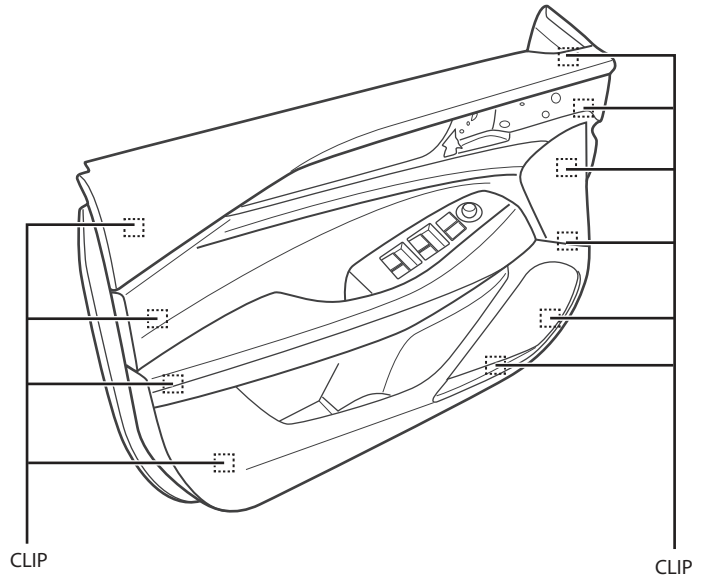
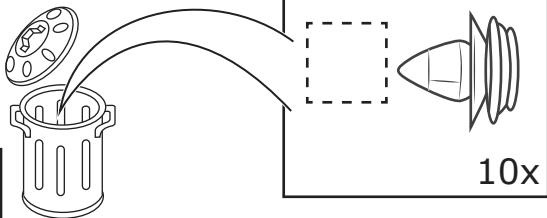

45

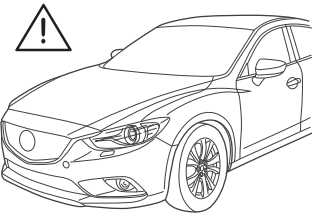

MAZDA 6 GH
 JMZGL *****600001 →

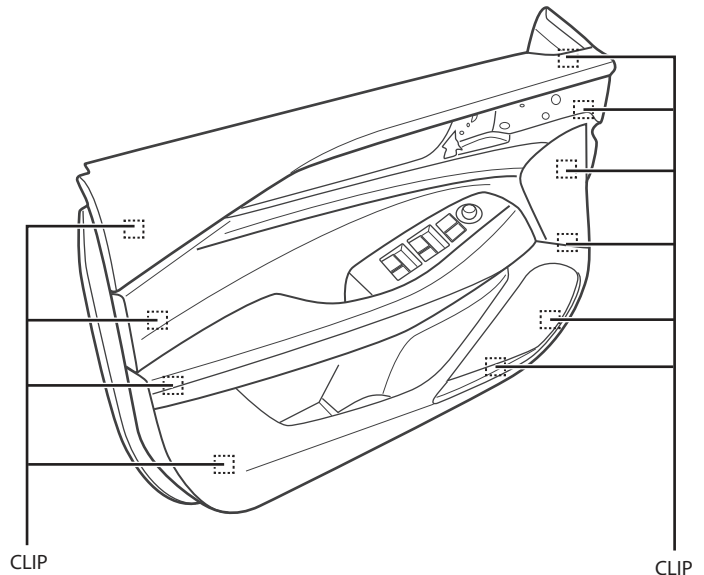
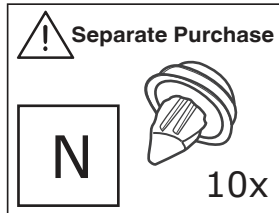

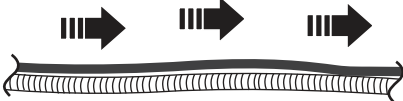

46

L+R 

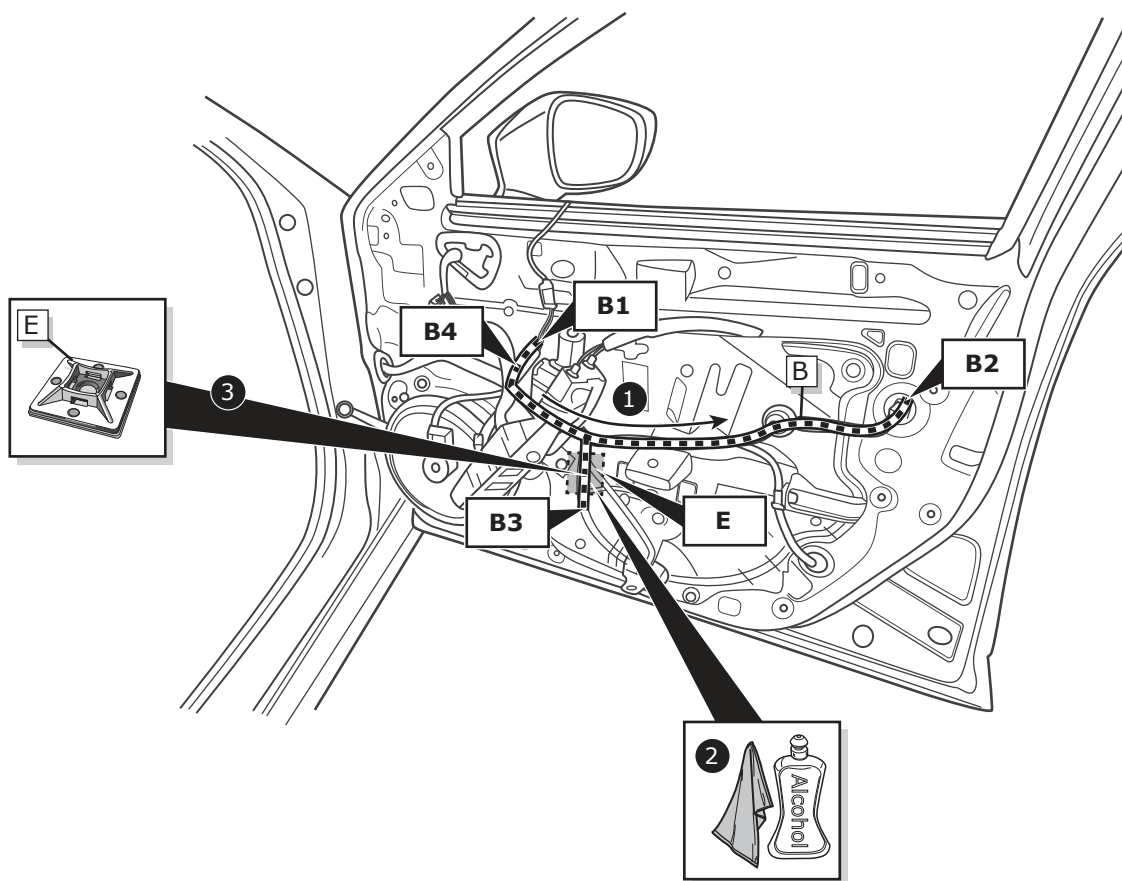
FOLLOW ORIGINAL WIRE

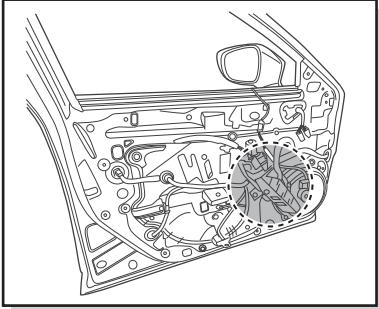
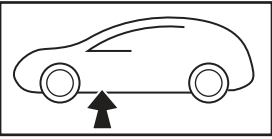



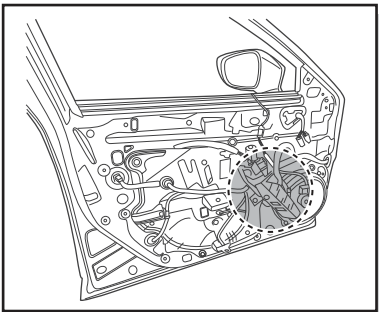
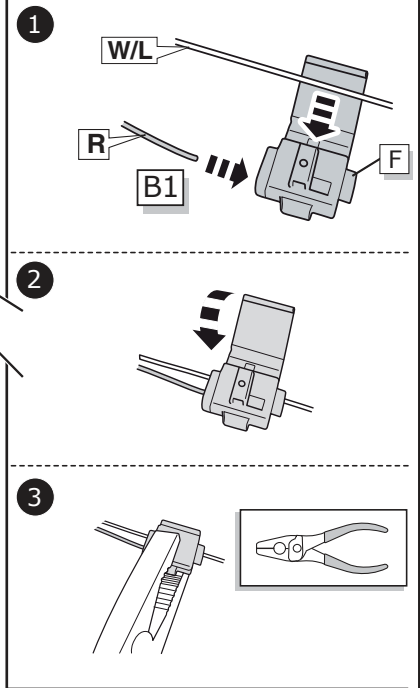
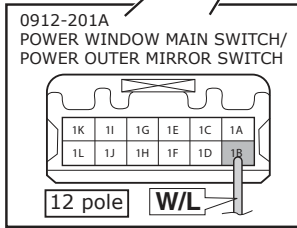
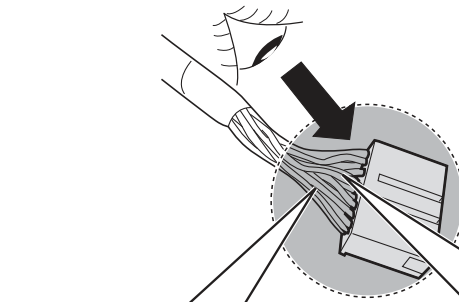

MAZDA 6 GJ
MAZDA 6 GH
 JMZGJ *****120400 →
 → JMZGL *****600000



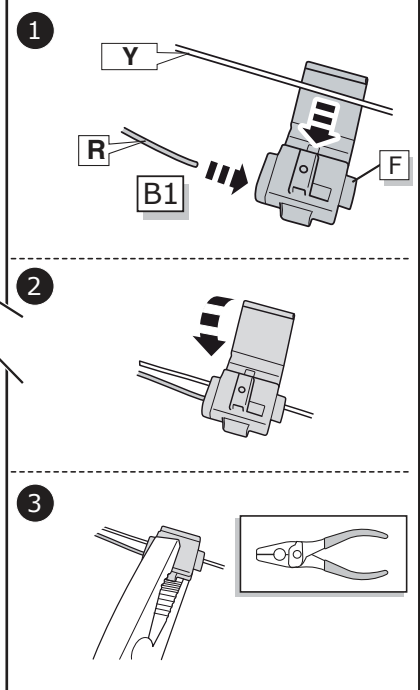
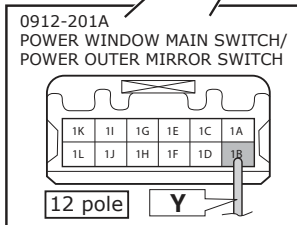
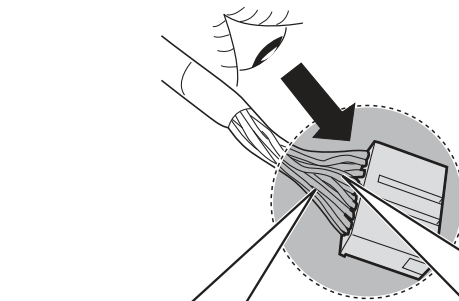

MAZDA 6 GH
 JMZGL *****600001 →

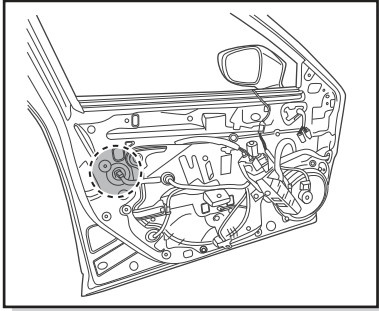
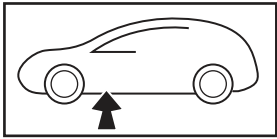

  **LHD**



 **MAZDA 6 GJ**
MAZDA 6 GH
 JMZGJ *****120400 →
 → JMZGL *****600000

0914-102
FRONT DOOR LATCH AND LOCK ACTUATOR (LH)

K	I	G	E	C	A
L	J	H	F	D	B

BR/B 12 pole

0914-210
FRONT DOOR LATCH AND LOCK ACTUATOR (LH)

K	I	G	E	C	A
L	J	H	F	D	B

BR/B 12 pole

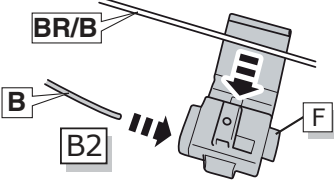
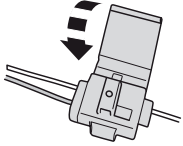
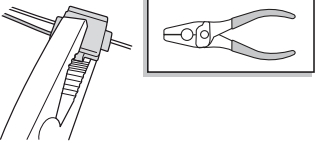
- 
- 
- 

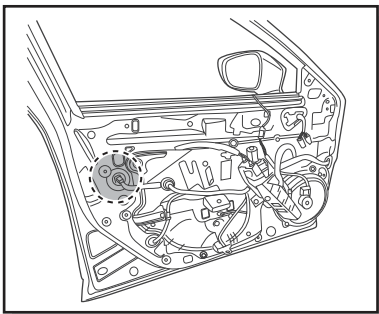

 **MAZDA 6 GH**
 JMZGL *****600001 →

0914-102
FRONT DOOR LATCH AND LOCK ACTUATOR (LH)

K	I	G	E	C	A
L	J	H	F	D	B

BR 12 pole

0914-210
FRONT DOOR LATCH AND LOCK ACTUATOR (LH)

K	I	G	E	C	A
L	J	H	F	D	B

BR 12 pole

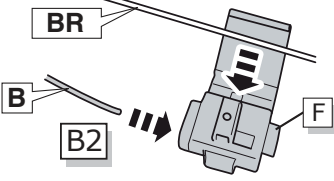
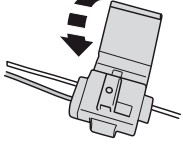
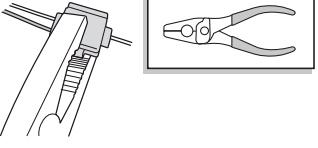
- 
- 
- 

  **LHD**

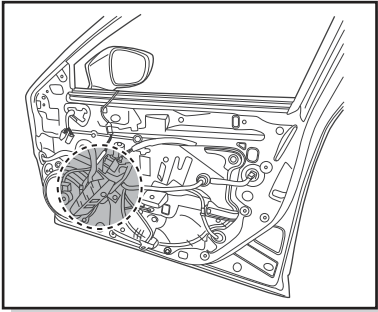
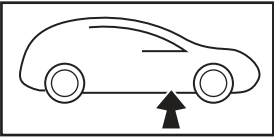

 **MAZDA 6 GJ**
MAZDA 6 GH
 JMZGJ *****120400 →
 → JMZGL *****600000

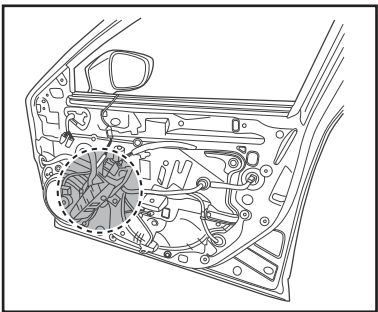
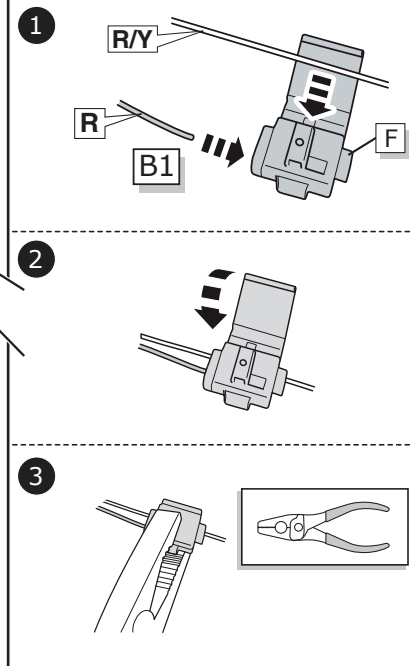
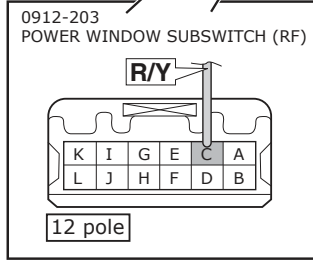

 **MAZDA 6 GH**
 JMZGL *****600001 →

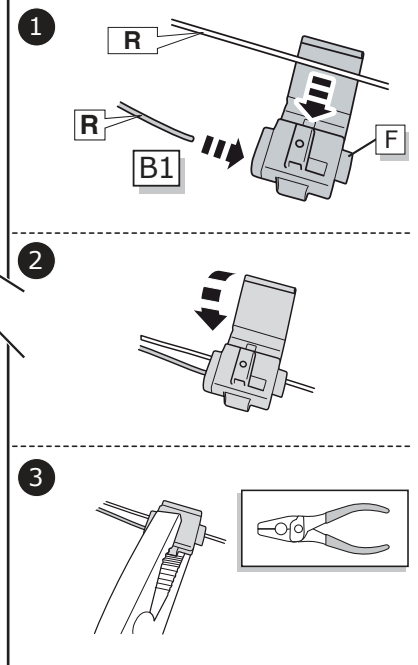
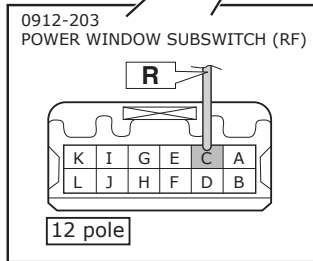

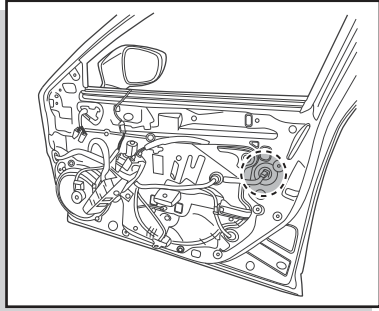
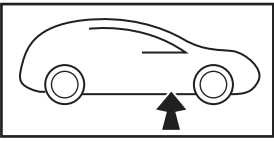

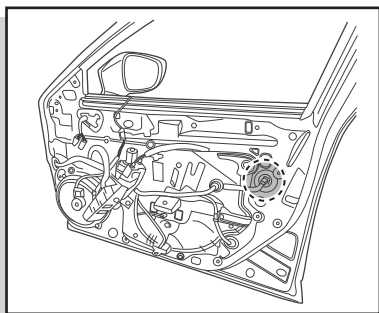
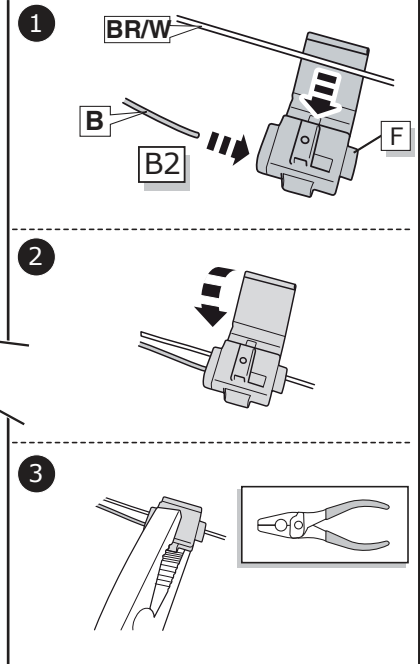
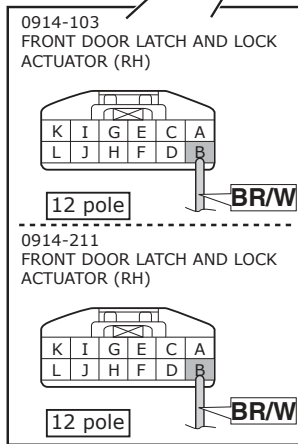

MAZDA 6 GJ
MAZDA 6 GH
 JMZGJ *****120400 →
 → JMZGL *****600000

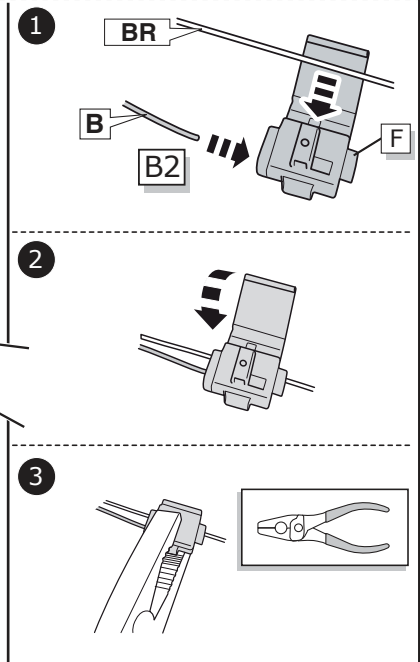
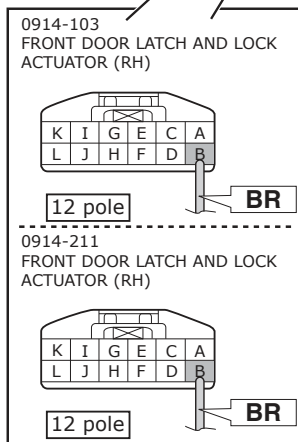

MAZDA 6 GH
 JMZGL *****600001 →

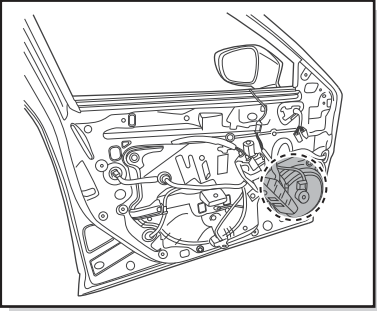
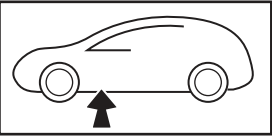
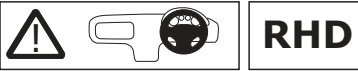



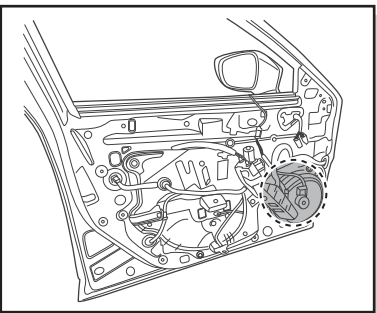
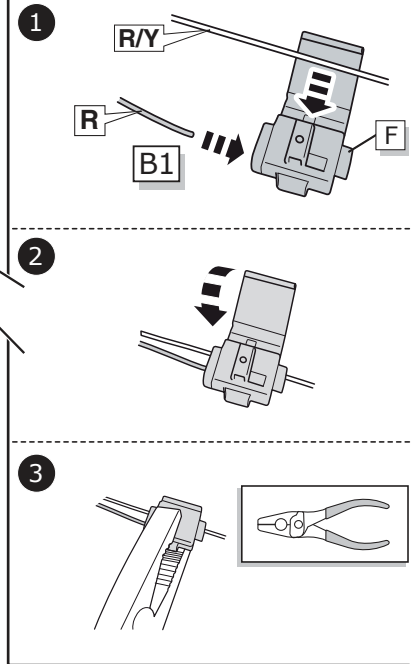
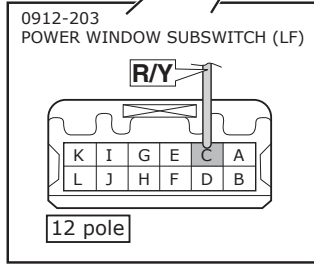
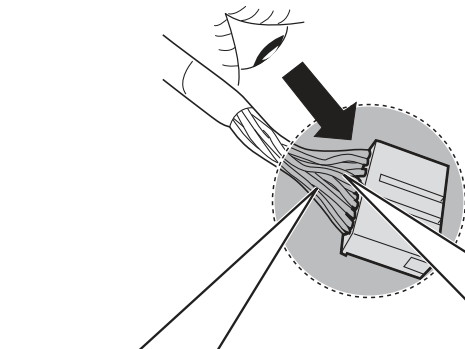

MAZDA 6 GJ
MAZDA 6 GH
 JMZGJ *****120400 →
 → JMZGL *****600000



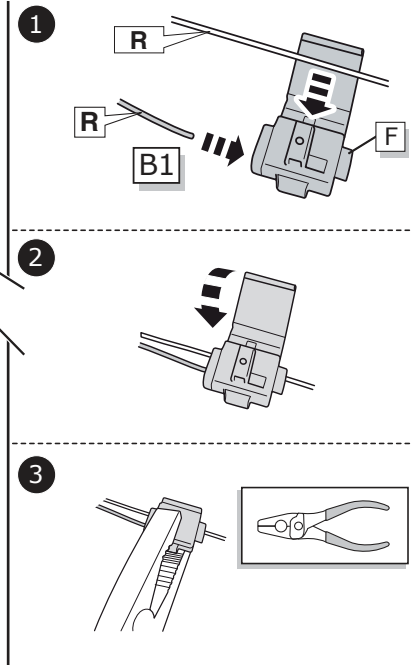
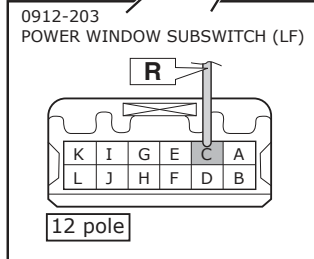
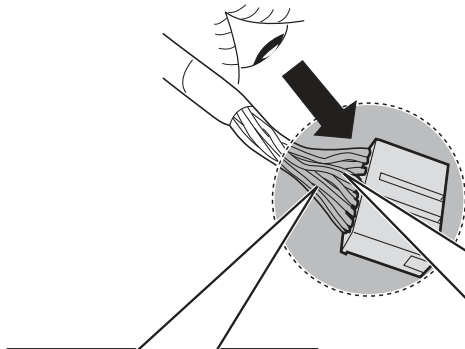

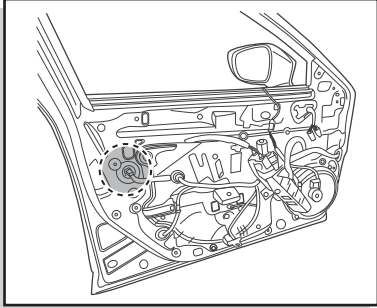
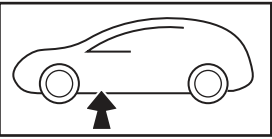
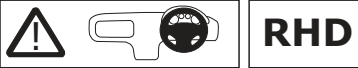
MAZDA 6 GH
 JMZGL *****600001 →





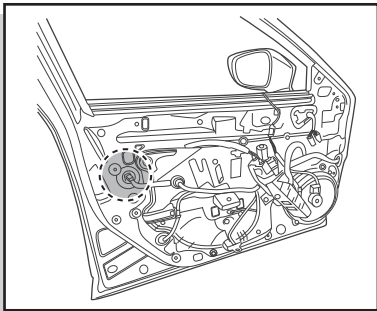
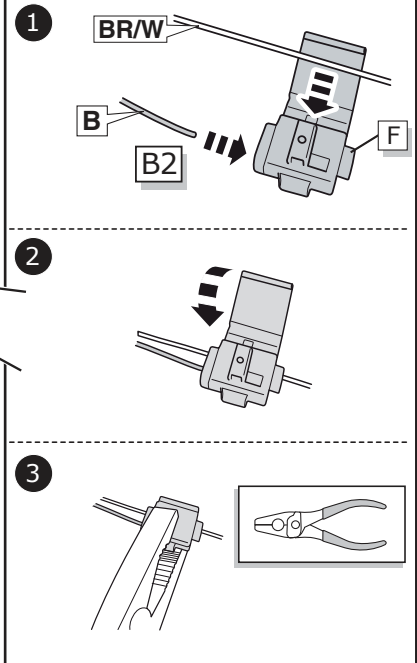
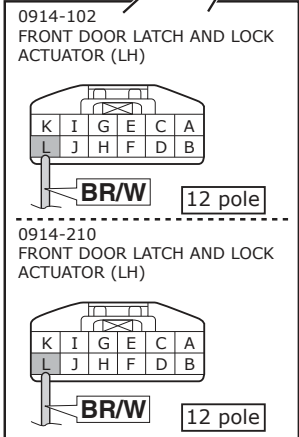
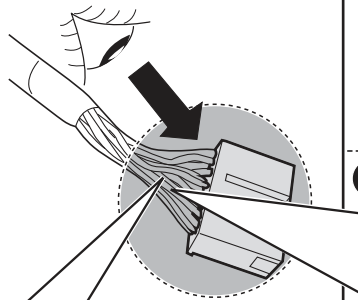

MAZDA 6 GJ
MAZDA 6 GH
 JMZGJ *****120400 →
 → JMZGL *****600000



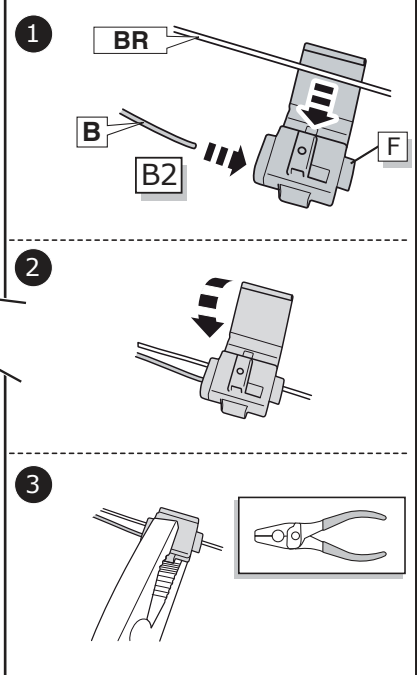
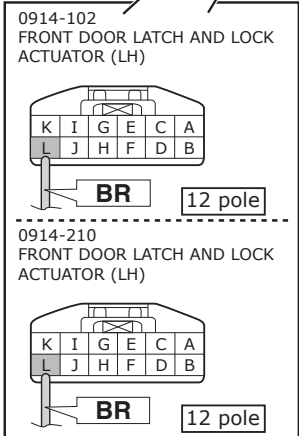
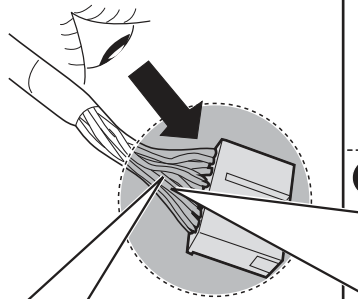

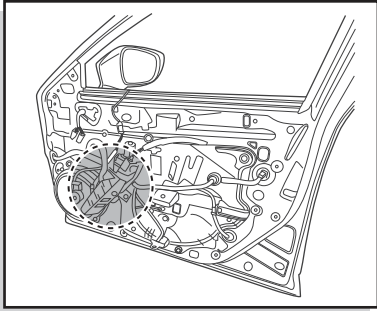
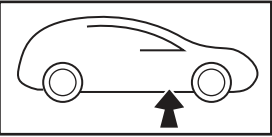
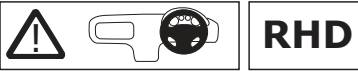
MAZDA 6 GH
 JMZGL *****600001 →





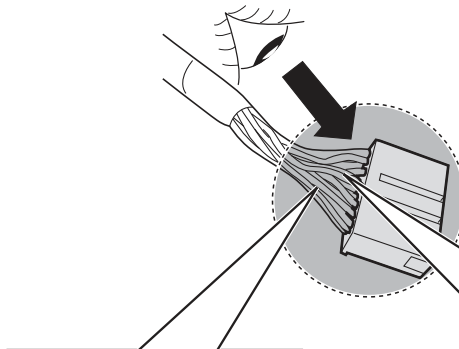

MAZDA 6 GJ
MAZDA 6 GH
 JMZGJ *****120400 →
 → JMZGL *****600000

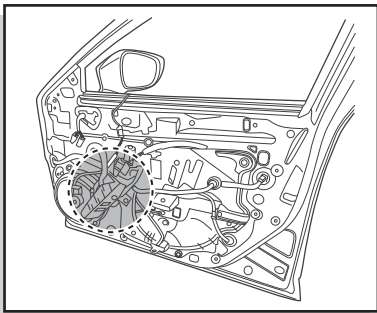
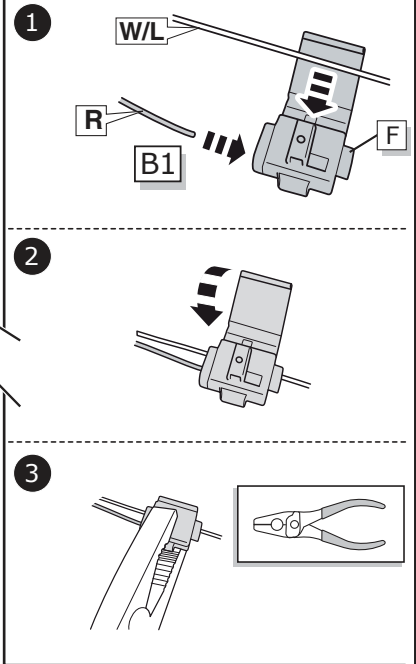
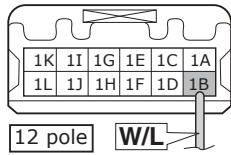

0912-201A
POWER WINDOW MAIN SWITCH/
POWER OUTER MIRROR SWITCH
DOOR LOCK SWITCH (RH)



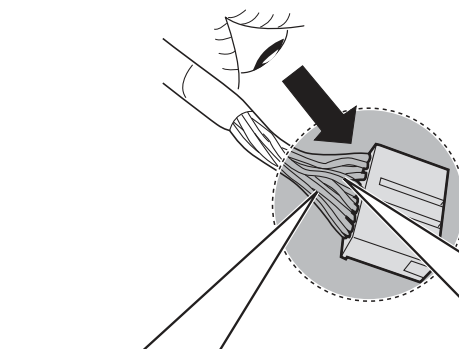

MAZDA 6 GH
 JMZGL *****600001 →

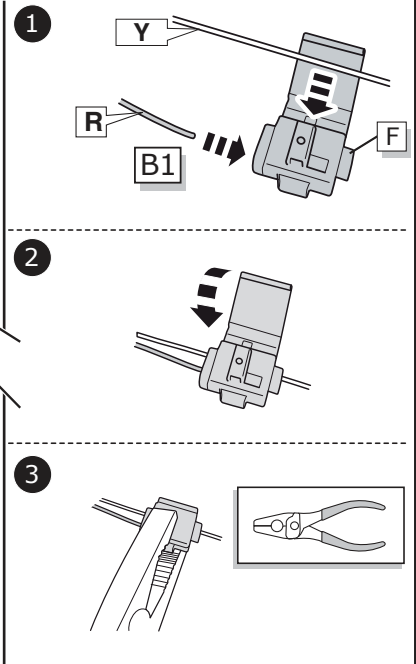
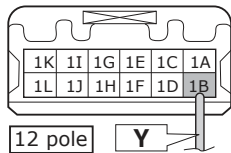

0912-201A
POWER WINDOW MAIN SWITCH/
POWER OUTER MIRROR SWITCH
DOOR LOCK SWITCH (RH)

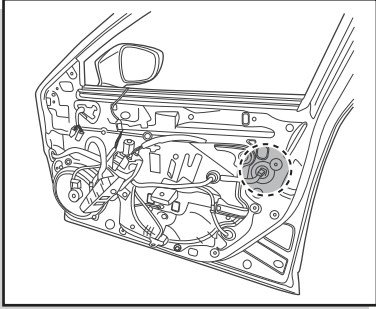
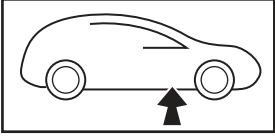

  **RHD**



 **MAZDA 6 GJ**
MAZDA 6 GH
 JMZGJ *****120400 →
 → JMZGL *****600000

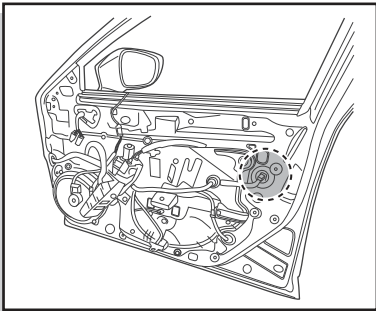
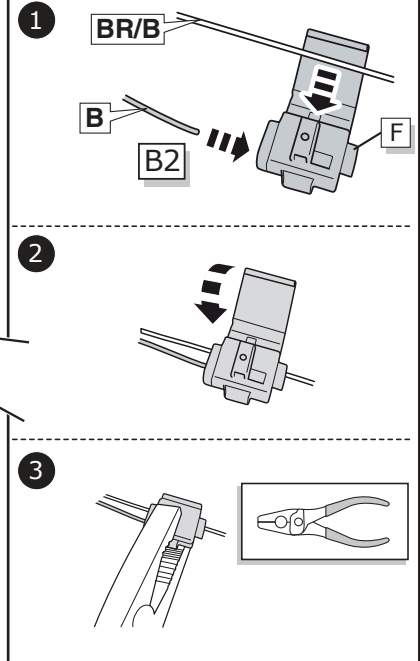
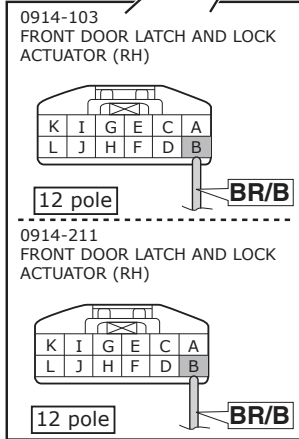

 **MAZDA 6 GH**
 JMZGL *****600001 →

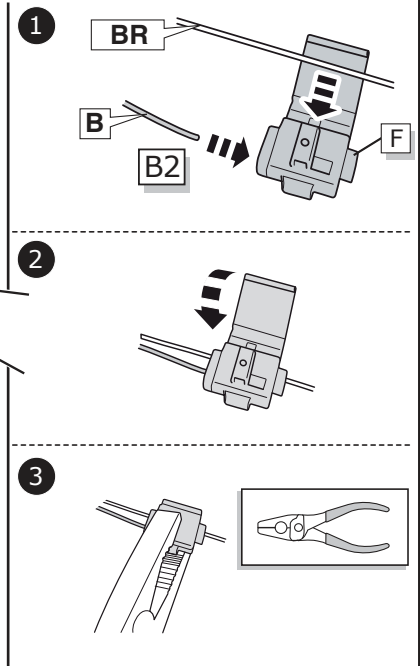

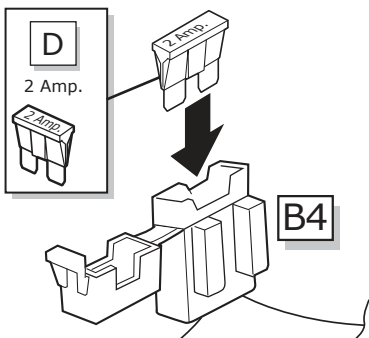

D
2 Amp.

B4

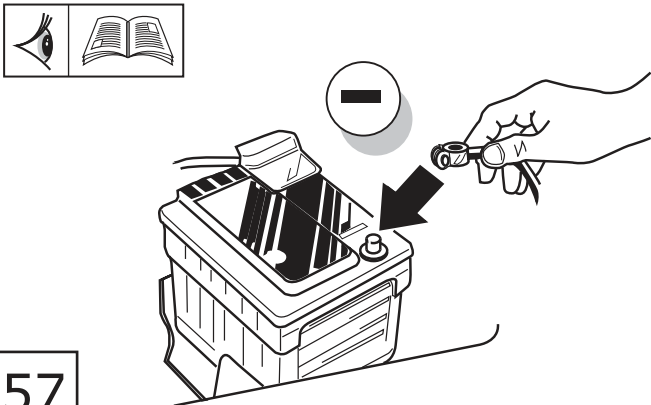

56
2x
57

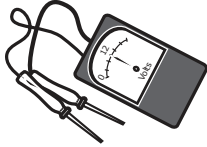
B3

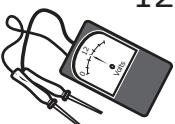

12 Volt

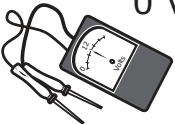

0 Volt

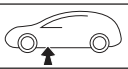
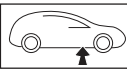
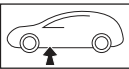
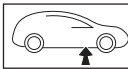
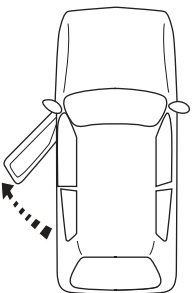
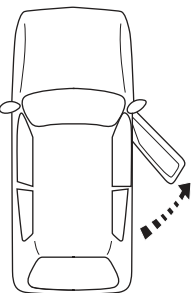
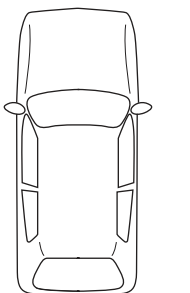
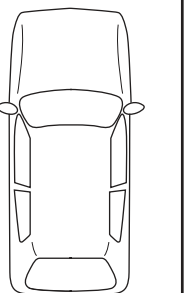
				
				
	✓	✓	✗	✗
	✗	✗	✓	✓

58





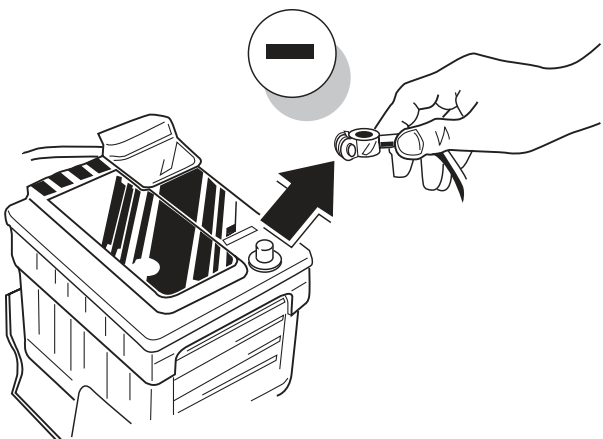

59

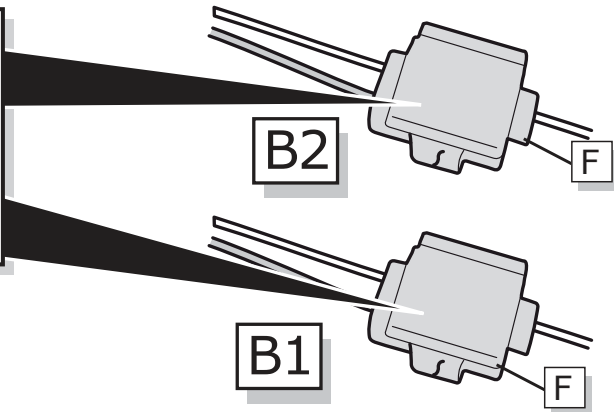
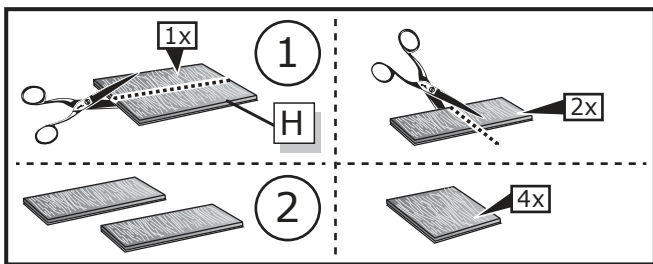
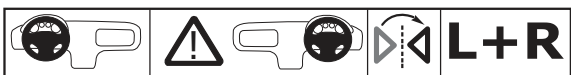

60

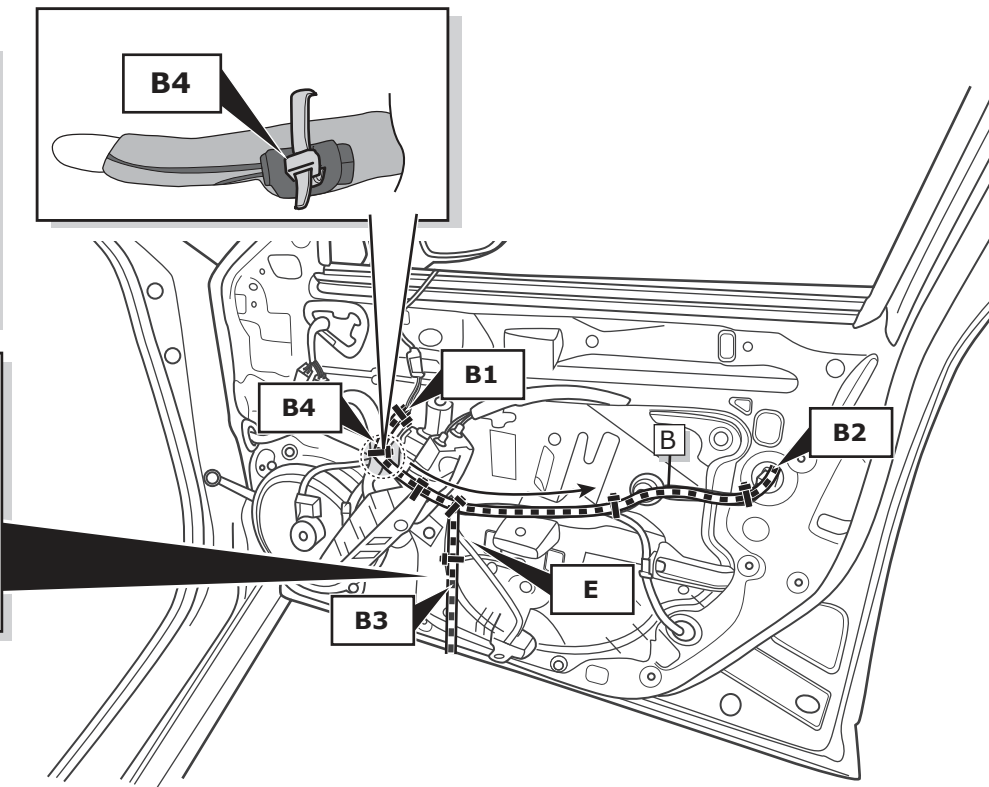
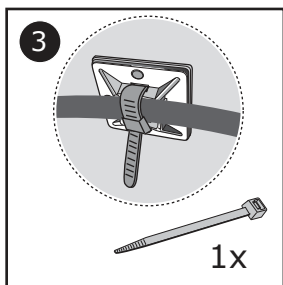
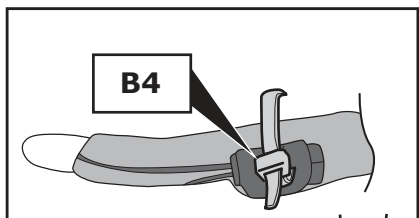
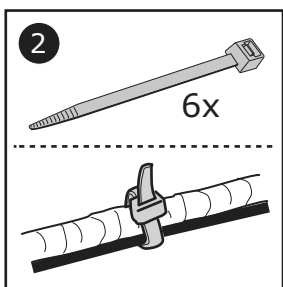

61

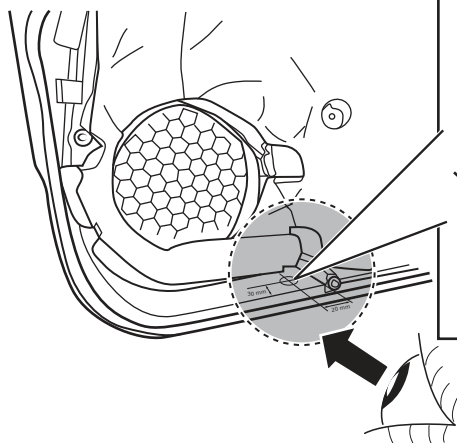
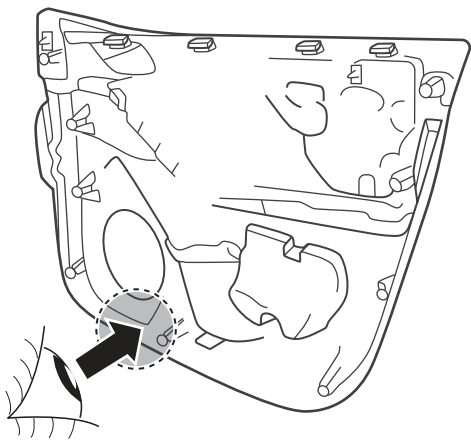
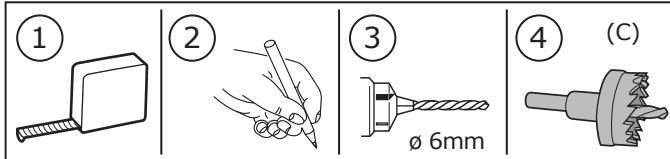
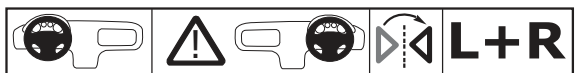

62

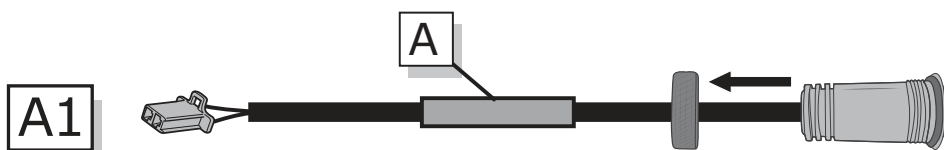

63

2x

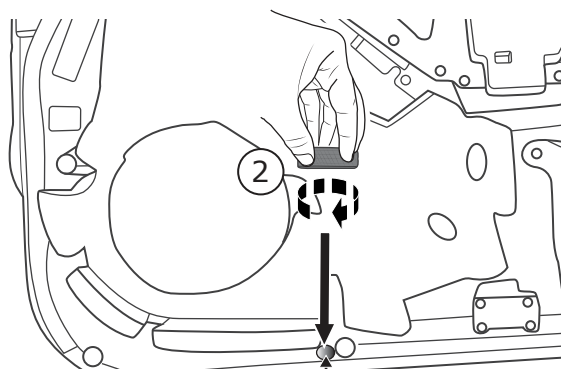
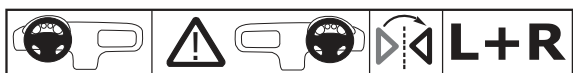

64

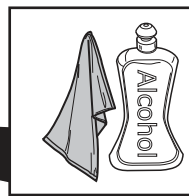
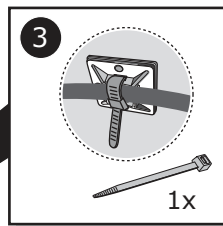
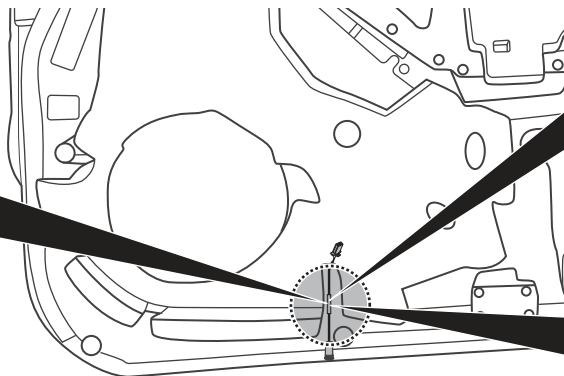
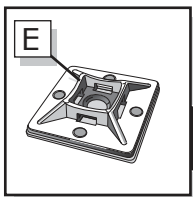

65

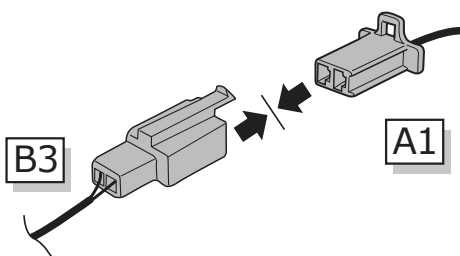
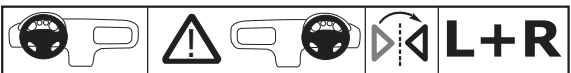

66

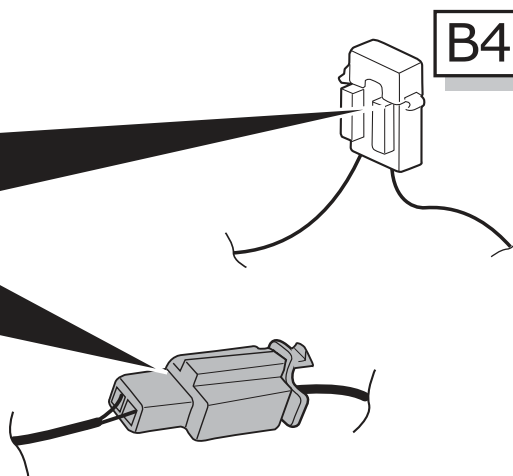
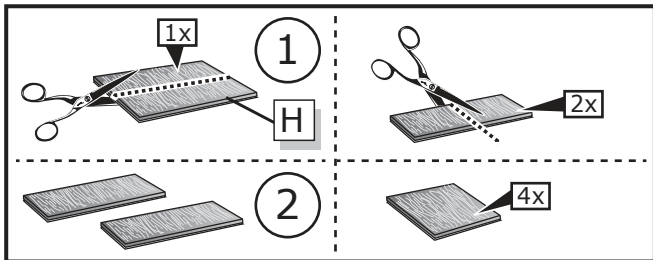
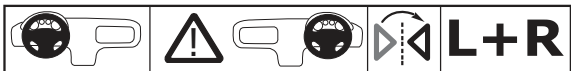

67

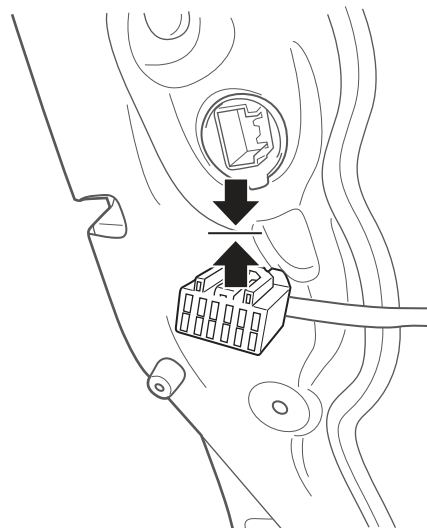
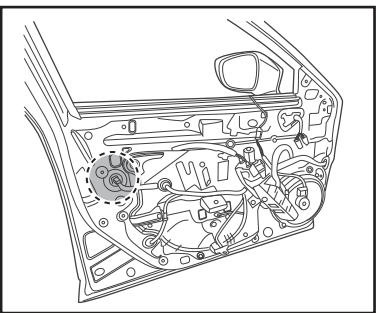

68

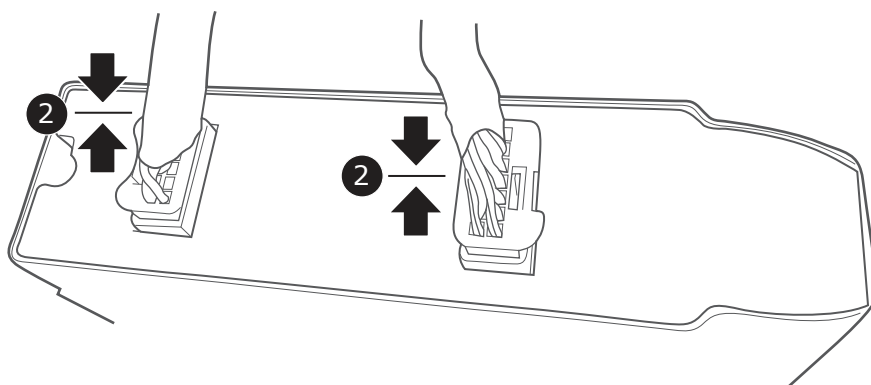
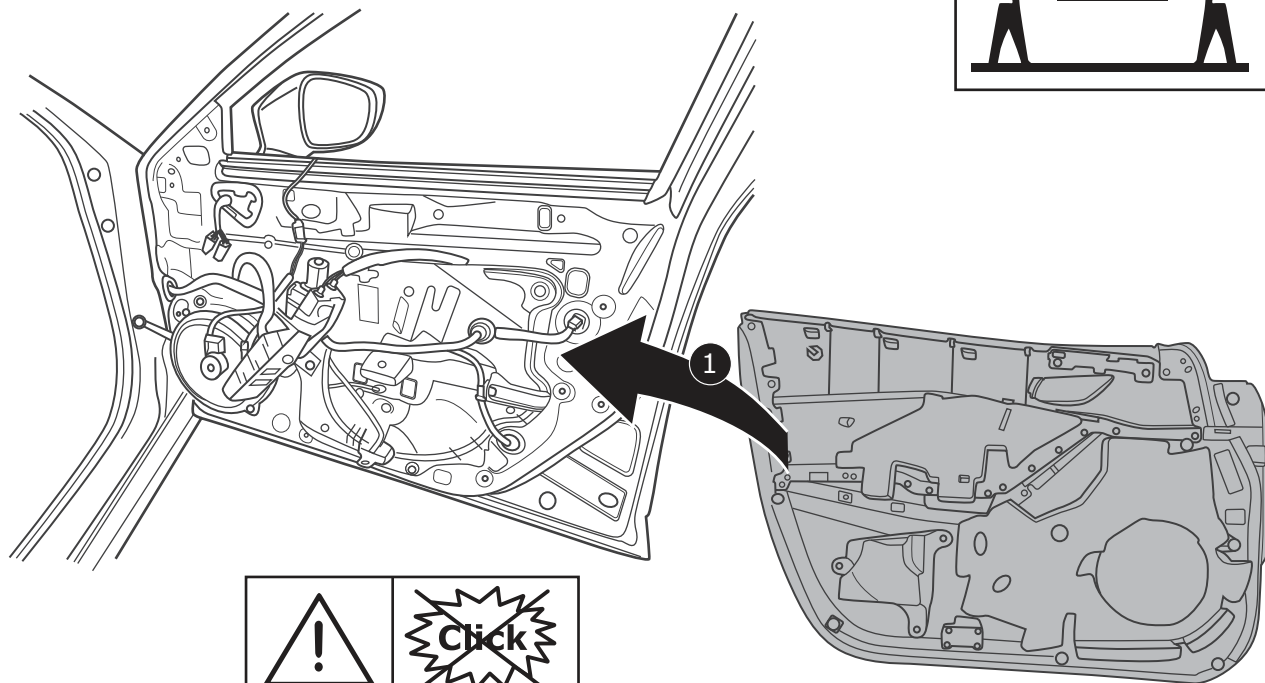
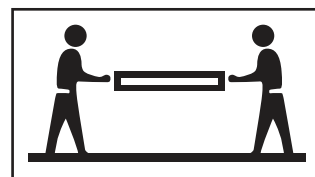

69

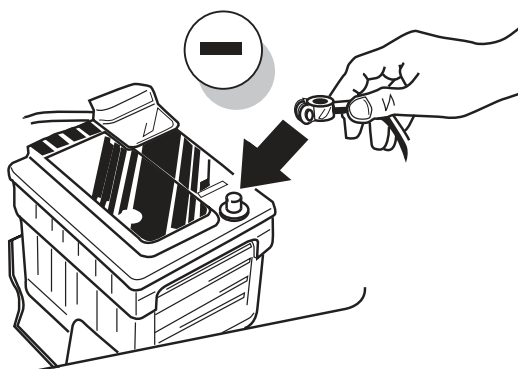

70

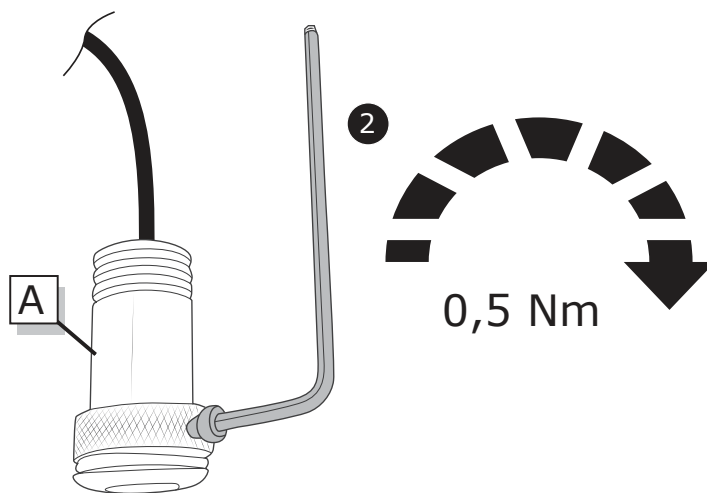
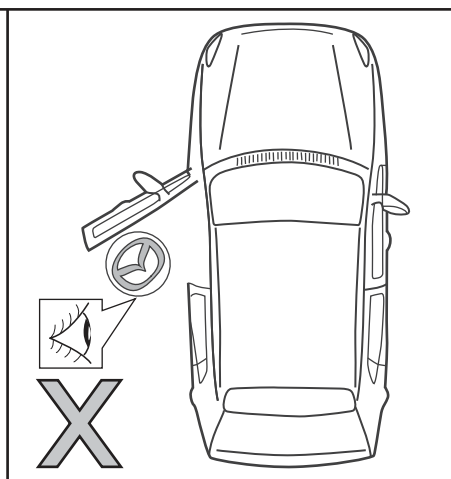
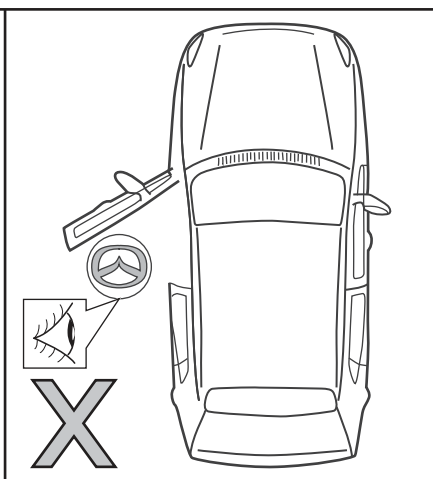
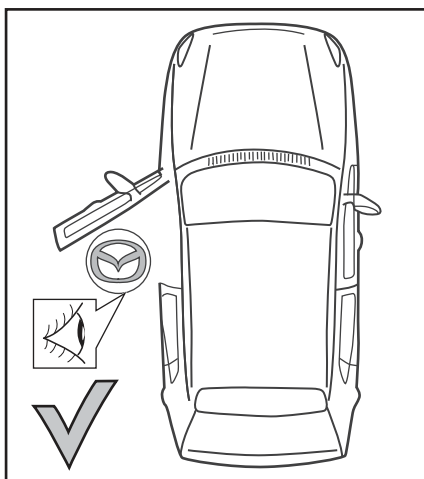
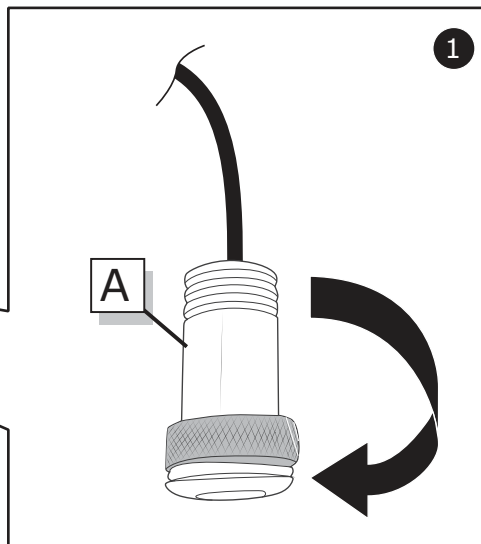
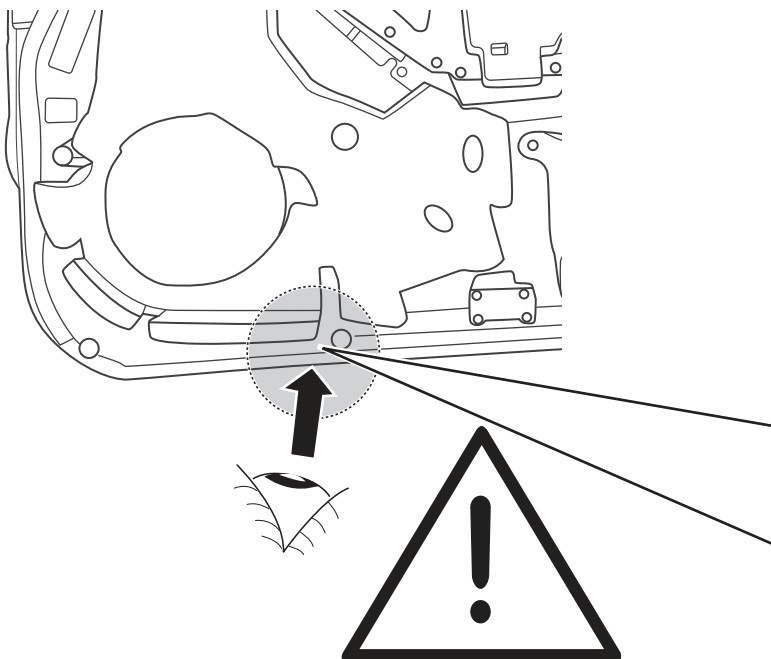
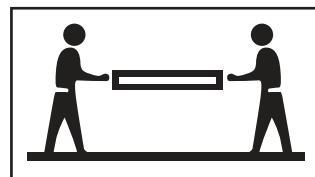



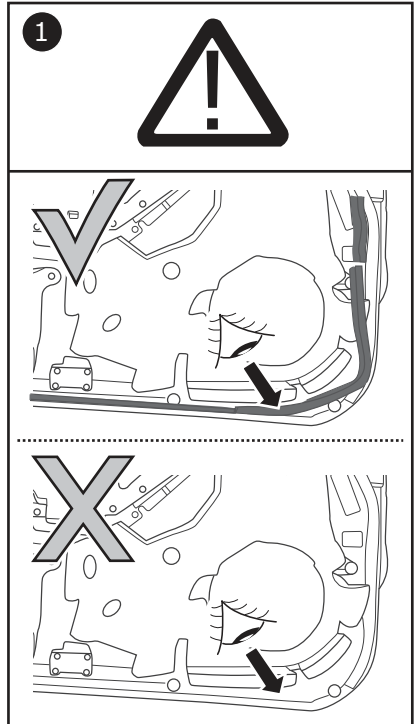
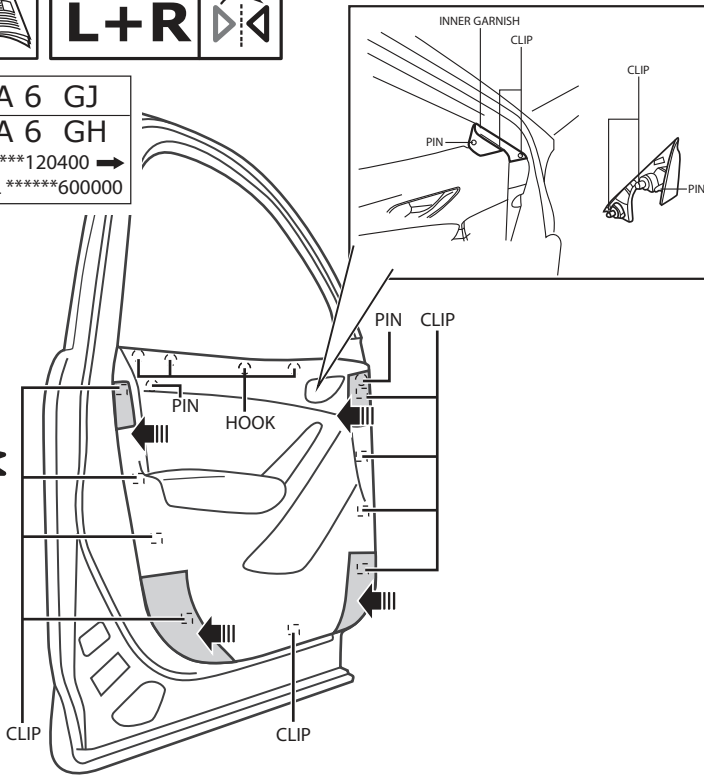

MAZDA 6 GJ
MAZDA 6 GH
 JMZGJ *****120400 →
 → JMZGL *****600000

Click



72



MAZDA 6 GJ
MAZDA 6 GH
 JMZGJ *****120400 →
 → JMZGL *****600000

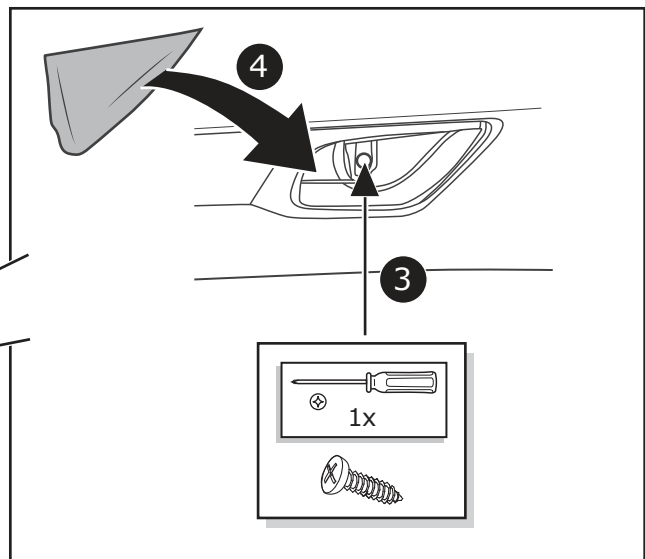
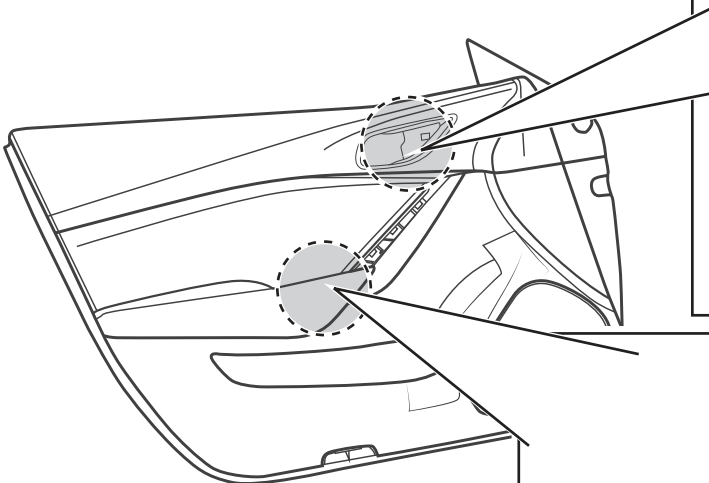

73

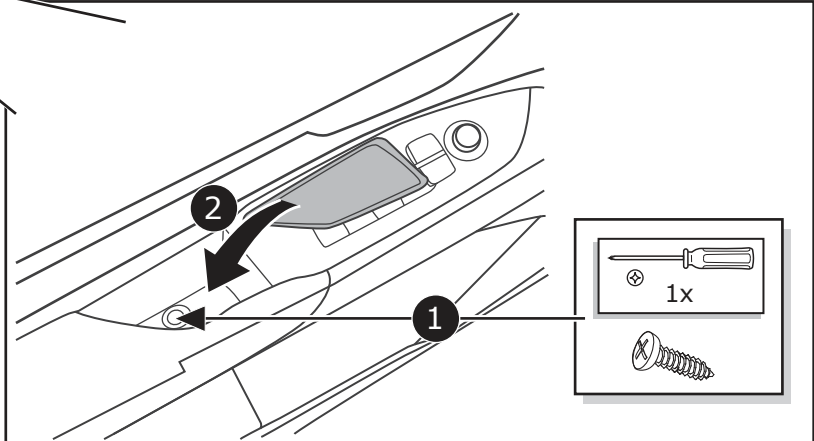



MAZDA 6 GH
JMZGL *****600001 →

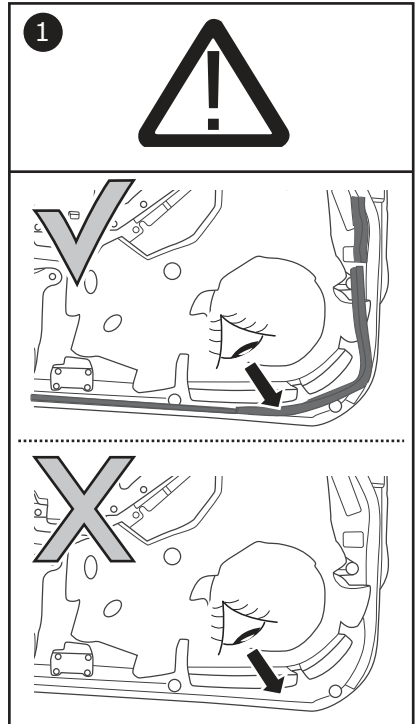
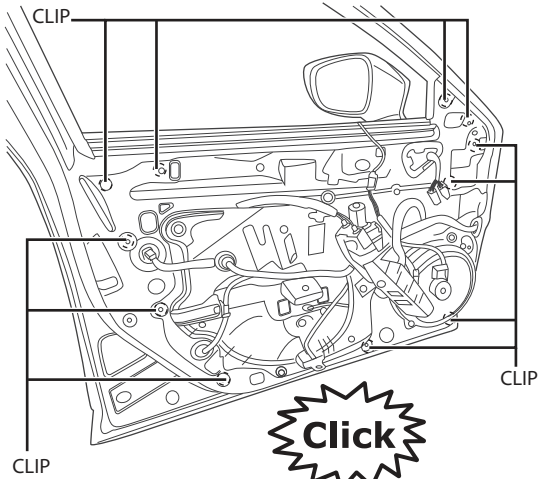

74



MAZDA 6 GH
JMZGL *****600001 →

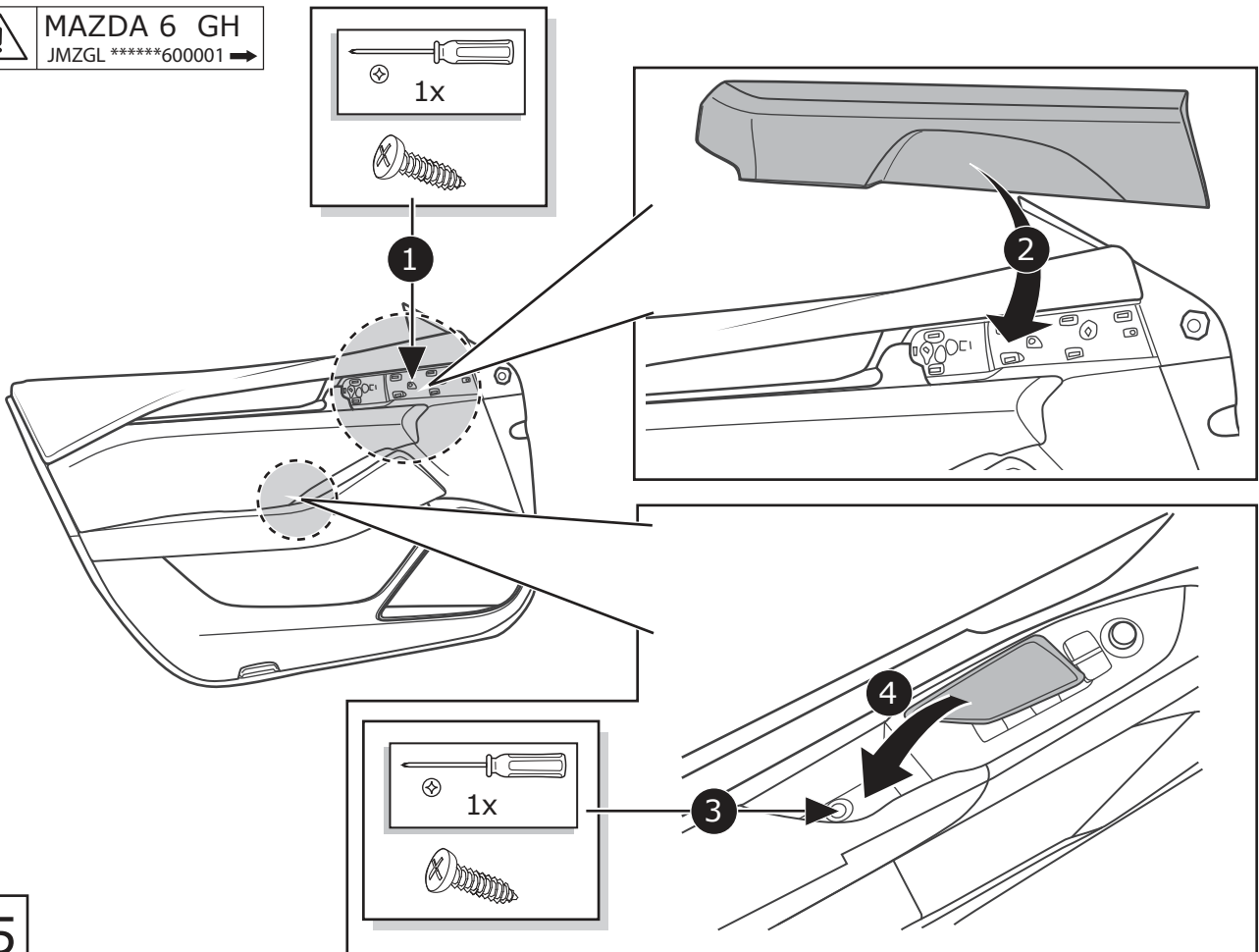

75

Subject to alteration without notice
Technische Änderungen vorbehalten
Reservadas modificaciones técnicas
Sous réserve de modifications techniques
Con riserva di apportare modifiche tecniche
Reservamo-nos o direito a alterações técnicas
Technische wijzigingen voorbehouden
Med forbehold for tekniske índringer
Tekniske forendringer forbeholdes
Med reservation för tekniska ändringar
Tekniset muutokset pidätetään
Technické zmeny vyhrazeny
A változtatások technika jogát fenntartjuk
Zmiany techniczne zastrzeżone
Επιφυλασσόμεθα για αλλαγές