

# MAZDA

<b>GB</b> ROOF RAIL Installation Instructions	<b>N</b> TAKRAILS Monteringsveiledning
<b>D</b> DACHREILING Einbauanleitung	<b>S</b> TAKRELINGAR Monteringsanvisning
<b>E</b> RIEL DE TECHO Instrucciones de Montaje	<b>SF</b> KATTOLISTAT Asennusohje
<b>F</b> BARRE DE TOIT Instructions de Montage	<b>CZ</b> STŘEŠNÍ NOSIČ Návod k Montáži
<b>I</b> BINARIO PER PORTAPACCHI Istruzioni di Montaggio	<b>H</b> TETŐSÍN Beszerelési Utasítása
<b>P</b> TRILHO DE TETO Instruções de Montagem	<b>PL</b> RELING DACHOWY Instrukcja Instalowania
<b>NL</b> DAKRAILS Inbouw-Instructie	<b>GR</b> ΡΑΓΑ ΟΡΟΦΗΣ Οδηγίες Τοποθέτησης
<b>DK</b> TAGRÆLING Monteringsveiledning	<b>RU</b> ПРОДОЛЬНЫЙ БРУС КРЫШИ КУЗОВА Инструкции по установке

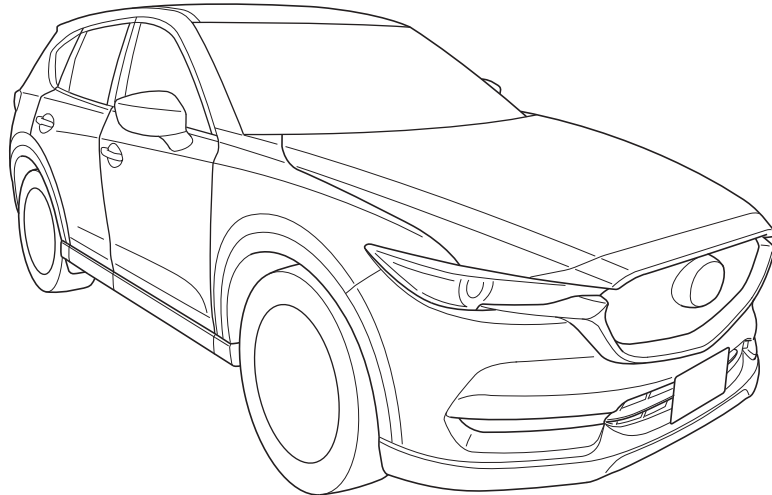

MAZDA CX-5 KF

Part No: KB8S V3 830

Date: 30-01-2017

© Copyrights MAZDA

Sheet 1 of 4

Expert Fitment Required  
Montage durch Fachwerkstatt erforderlich  
Montaje sólo por el concesionario  
Montage par spécialiste nécessaire  
E' necessario in officina specializzata  
Especialista em montagem requerido  
Montage door vakman nodig  
Montage ved professionelt værksted påkrævet  
Nødvendig med montering fra fagvejverksted  
Verkstadsmontage erfordras  
Asennus tarpeen merkkikorjaamossa  
Montáž ve specializované dílně nutná  
A szereléshez szakműhely kell  
Konieczny montaż przez warsztat specjalistyczny  
Να τοποθετεί από συνεργείο  
Необходима подгонка специалистом

KFE1-3830-00



- (GB) Position arrow
- (D) Positionspfeil
- (E) Flecha de posición
- (F) Flèche de position
- (I) Freccia di posizione
- (P) Flexa de posição
- (NL) Lokatie/Positie pijl
- (DK) Lokaliseringspil
- (N) Posisjonspil
- (S) Positionpil
- (SF) Paikannusnuoli
- (CZ) Šipka na pozici
- (H) Helyzetjelző nyíl
- (PL) Strzałka położenia
- (GR) Βέλος θέσης
- (RU) Стрелка расположения

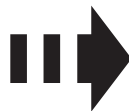

- (GB) Movement arrow
- (D) Bewegungspfeil
- (E) Flecha de movimiento
- (F) Flèche de mouvement
- (I) Freccia di movimento
- (P) Flexa de movimento
- (NL) Richtingspijl
- (DK) Bevægelsespil
- (N) Bevegelsespil
- (S) Rørelsepil
- (SF) Liikesuuntanuoli
- (CZ) Šipka pohybu
- (H) Mozgásirányjelző nyíl
- (PL) Strzałka kierunku ruchu
- (GR) Βέλος κίνησης
- (RU) Стрелка движения



- (GB) Same procedure for the left and right side
- (D) Gleicher einbau für linke und rechte seite
- (E) Mismo procedimiento para lado izquierdo y derecho
- (F) Procédure identique pour les côtés gauche et droit
- (I) Stessa procedura valida per il lato destro e sinistro
- (P) Mesmo procedimento para o lado esquerdo e direito
- (NL) Dezelfde procedure voor de linker en rechter zijde
- (DK) Samme fremgangsmåde for venstre og højre side
- (N) Samme prosedyre for venstre og høyre side
- (S) Samma åtgärd för vänster och höger sida
- (SF) Samat toimenpiteet vasemmalle ja oikealle puolelle
- (CZ) Postup je stejný pro levou i pravou stranu
- (H) Az eljárás azonos a bal és a jobboldalon
- (PL) Te same czynności należy wykonać po lewej i prawej stronie
- (GR) Ίδια διαδικασία για την αριστερή και τη δεξιά πλευρά
- (RU) Однаковая последовательность действий как для левой, так и для правой стороны



- (GB) Throw away
- (D) Entsorgen
- (E) Tratamiento de residuos
- (F) Rebuter
- (I) Smaltire
- (P) Eliminar
- (NL) Weggoaien
- (DK) Affald
- (N) Avskaffe
- (S) Ta hand om avfallet
- (SF) Hävittää
- (CZ) Vyhodit
- (H) Távolítsa el
- (PL) Usunąć jako odpad
- (GR) Απόσυρση
- (RU) Выбросите



- (GB) Warning
- (D) Achtung
- (E) Atención
- (F) Attention
- (I) Attenzione
- (P) Atenção
- (NL) Let op
- (DK) Bemærk
- (N) Pass på
- (S) Varning
- (SF) Huomio
- (CZ) Pozor
- (H) Figyelem
- (PL) Uwaga
- (GR) Προσοχή
- (RU) Осторожно



- (GB) See workshop manual
- (D) Siehe werkstatthandbuch
- (E) Ver manual de taller
- (F) Voir manuel d'atelier
- (I) Vedere manuale officina
- (P) Cf. o manual da oficina
- (NL) Zie werkplaatshandboek
- (DK) Se værkstedshåndbog
- (N) Se verkstedshåndboka
- (S) Se verkstadshandboken
- (SF) Katso korjaamon käsikirjasta
- (CZ) Viz dílenskou příručku
- (H) Lásd a műhely-kézikönyvben
- (PL) Patrz podręcznik warsztatowy
- (GR) λέτε Εγχειρίδιο Συνεργείου
- (RU) Смотри руководство для мастерской



- (GB) Temporarily tightening
- (D) Provisorisch festziehen
- (E) Apretar temporariamente
- (F) Serrage provisoire
- (I) Per stringere temporaneamente
- (P) Apertar temporariamente
- (NL) Provisorisch vastdraaien
- (DK) Midlertidig stramning
- (N) Midlertidig stramning
- (S) Tillfällig fastdragnig
- (SF) Tilapäinen kiristys
- (CZ) Přechodné utážení
- (H) Ideiglenes meghúzás
- (PL) Dokręcenie tymczasowe
- (GR) Προσωρινό βίδωμα
- (RU) Временное затягивание

**A**



**L** X 1  
**R** X 1

**B**

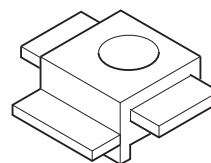

X 12

**C**

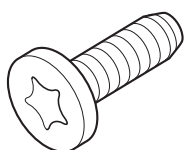

X 12

**D**

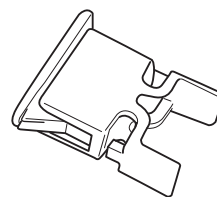

X 12

**E**

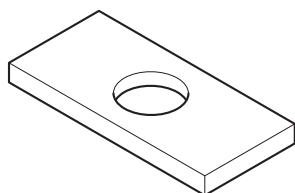

X 12

**F**

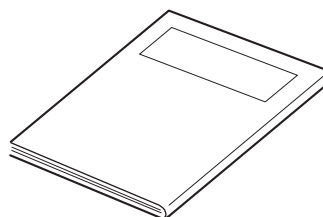

X 1

Spare:K123-V3-839

**B**

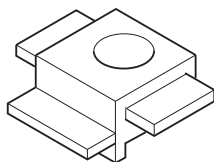

X 6

**C**

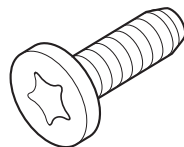

X 6

**E**

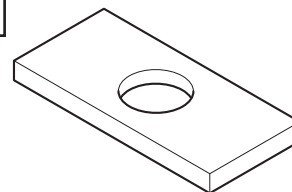

X 6

Spare:K123-V3-83E

**D**

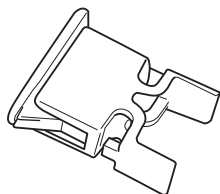

X 6

**1**  **L+R**

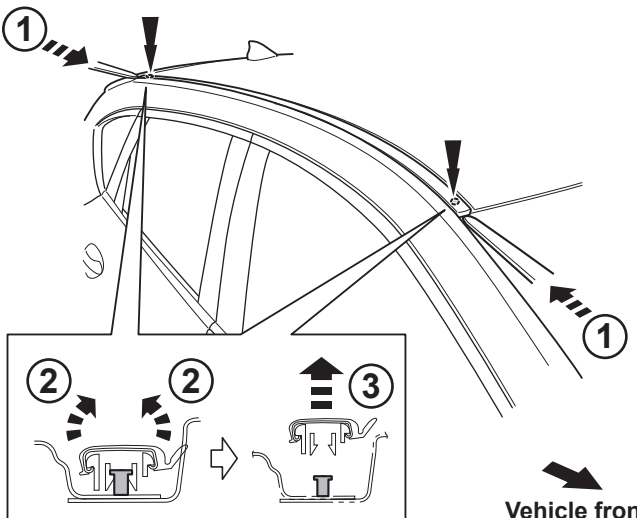

Vehicle front

**2** **L+R**

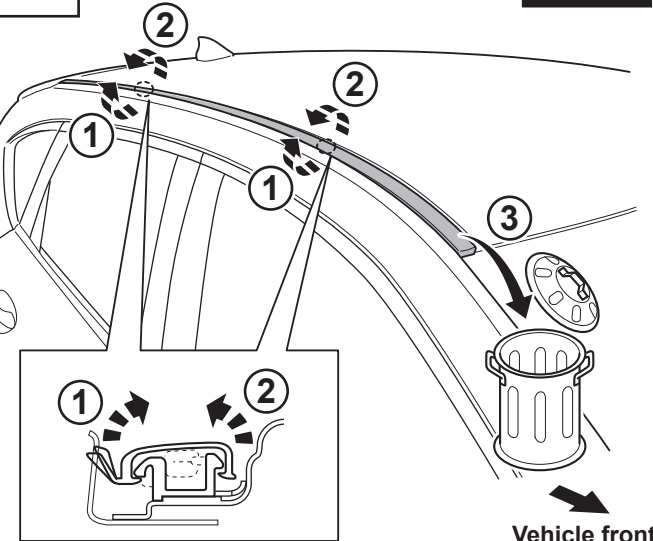

Vehicle front

**3** **L+R**

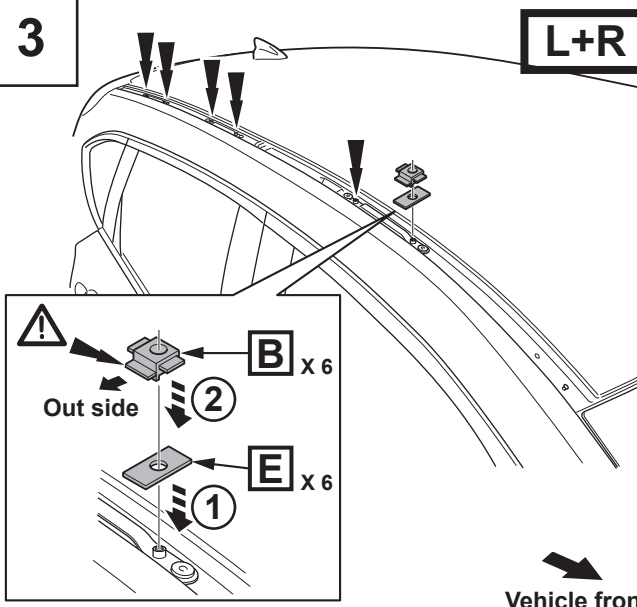

Vehicle front

**4** **L+R**

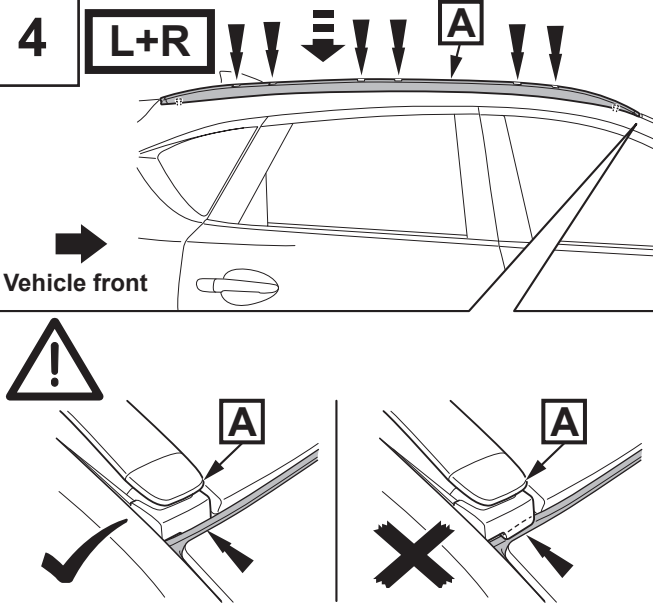

Vehicle front

**5** **L+R**

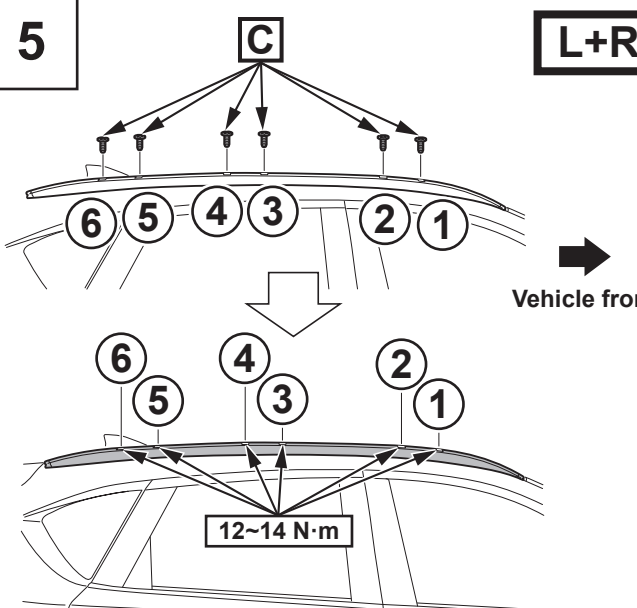

Vehicle front

12~14 N·m

**6** **L+R**

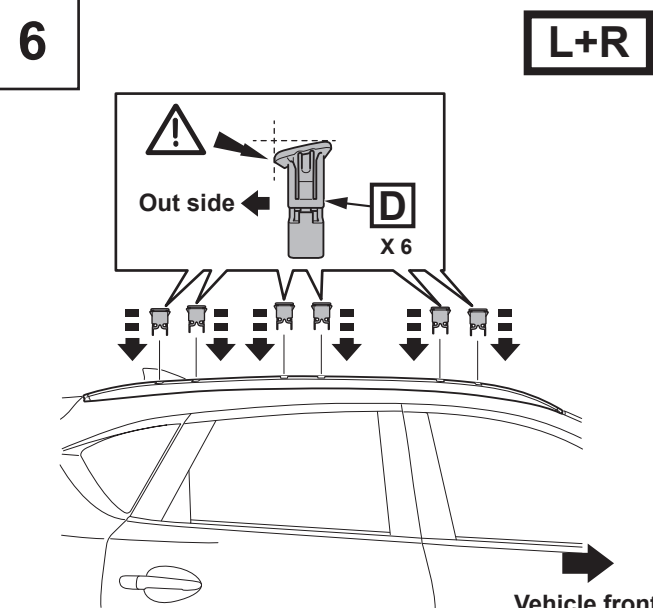

Vehicle front