

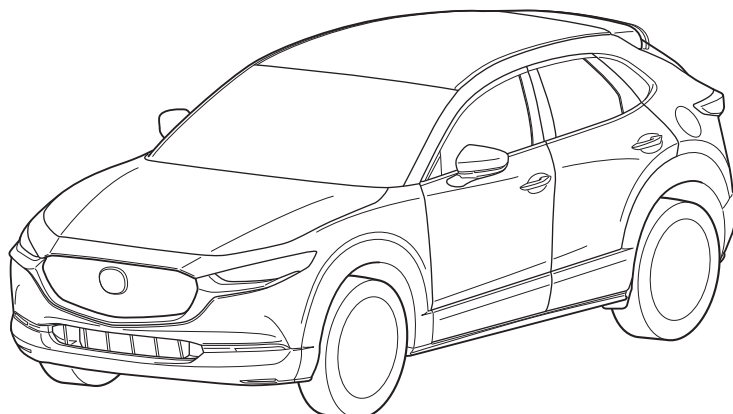

MAZDA

GB MUD FLAP (FRONT) Installation Instructions	S STÄNKSKYDD (FRAM) Monteringsanvisning
D SCHMUTZFÄNGER (VORNE) Einbauanleitung	SF ROISKELÄPPÄ (ETU) Asennusohje
E ALETAS DE GUADABARROS (DELANTERAS) Instrucciones de Montaje	CZ ZÁSTĚRKY (PŘEDNÍ) Návod k Montáži
F BAVETTE GARDE-BOUE (AVANT) Instructions de Montage	H SÁRVÉDŐ (ELSŐ) Beszerelési Utasítása
I PARAFANGO (ANTERIORE) Istruzioni di Montaggio	PL CHŁAPACZ (PRZEDNI) Instrukcja Instalowania
P GUARDA LAMAS (DIANTEIROS) Instruções de Montagem	GR ΛΑΣΠΩΤΗΡΑΣ (ΜΠΡΟΣΤΑ) Οδηγίες εγκατάστασης
NL SPATLAP (VOOR) Inbouw-Instructie	RUS БРЫЗГОВИК (ПЕРЕДНИЙ) Инструкцию по установке
DK STÆNKLAP (FORAN) Monteringsvejledning	SVK BLATNÍK (PREDNÝ) Návod na inštaláciu
N SKVETTLAPPER (FORAN) Monteringsveiledning	



MAZDA CX-30

DM

Part No: **DFR5 V3 450**

Date: 21-03-2019

© Copyrights MAZDA

Sheet 1 of 6

Expert Fitting Required
Genau Montage erforderlich
Se requiere colocación profesional
Installation par un expert impérative
Necessaria installazione da parte di un esperto
Necessário ajuste especializado
Deskundige installatie vereist
Ekspertbeslag påkrævet
Montering av ekspert nødvendig
Expertmontering krävs
Edellyttää asiantuntijan asennusta
Nutná instalace odborníkem
Szakértői felszerelés szükséges
Wymagana instalacja przez specjalistę
Απαιτείται τοποθέτηση από ειδικό
Необходима профессиональная установка
Vyžaduje sa odborné vybavenie

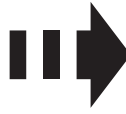

L+R

- (GB) Position arrow
- (D) Positionspfeil
- (E) Flecha de posición
- (F) Flèche de position
- (I) Freccia di posizione
- (P) Seta de posição
- (NL) Pijl positie
- (DK) Position pil
- (N) Posisjoneringspil
- (S) Positionspil
- (SF) Asentoa osoittava nuoli
- (CZ) Šipka pozice
- (H) Elhelyezkedési nyíl
- (PL) Strzałka pozycji
- (GR) Βέλος τοποθέτησης
- (RUS) Стрелка положения
- (SVK) Šipka polohy

- (GB) Movement arrow
- (D) Bewegungspfeil
- (E) Flecha de movimiento
- (F) Flèche de mouvement
- (I) Freccia di movimento
- (P) Seta de movimento
- (NL) Pijl beweging
- (DK) Bevægelse pil
- (N) Bevegelsespil
- (S) Rörelsepil
- (SF) Suuntaa osoittava nuoli
- (CZ) Šipka pohybu
- (H) Mozgási nyíl
- (PL) Strzałka ruchu
- (GR) Βέλος κίνησης
- (RUS) Стрелка движения
- (SVK) Šipka pohybu

- (GB) Same procedure for the left and right side
- (D) Gleiches Vorgehen für linke und rechte Seite
- (E) Mismo procedimiento para el lado izquierdo y derecho
- (F) Procédure identique à gauche et à droite
- (I) Stessa procedura per lato destro e sinistro
- (P) Mesmo procedimento para os lados direito e esquerdo
- (NL) Dezelfde procedure voor links en rechts
- (DK) Samme produkt for venstre og højre side
- (N) Samme prosedyre for venstre og høyre side
- (S) Samma procedur för vänster och höger sida
- (SF) Sama toimenpide vasemmalla ja oikealla puolella
- (CZ) Stejný postup pro levou i pravou stranu
- (H) Azonos eljárás a bal és a jobb oldal esetén egyaránt
- (PL) Ta sama procedura obowiązuje dla lewej i prawej strony
- (GR) Ίδια διαδικασία και για τις δύο πλευρές
- (RUS) Одинаковый порядок действий для левой и правой стороны
- (SVK) Rovnaký postup pre ľavú a pravú stranu



- (GB) Warning
- (D) Warnung
- (E) Advertencia
- (F) Avertissement
- (I) Avvertenza
- (P) Aviso
- (NL) Waarschuwing
- (DK) Advarsel
- (N) Advarsel
- (S) Varning
- (SF) Varoitus
- (CZ) Varování
- (H) Figyelmeztetés
- (PL) Ostrzeżenie
- (GR) Προειδοποίηση
- (RUS) Предупреждение
- (SVK) Výstraha

- (GB) See installation instructions
- (D) Siehe Installationsanleitung
- (E) Ver las instrucciones de instalación
- (F) Se reporter à la notice d'installation
- (I) Vedere le istruzioni di installazione
- (P) Consultar instruções de instalação
- (NL) Zie montageinstructies
- (DK) Se monteringsanvisninger
- (N) Se monteringsinstruksjonene
- (S) Se monteringsinstruktioner
- (SF) Katso asennusohjeet
- (CZ) Viz návod k instalaci
- (H) Lásd: Telepítési utasítások
- (PL) Zapoznać się z instrukcją instalacji
- (GR) Βλ. οδηγίες εγκατάστασης
- (RUS) См. инструкцию по установке
- (SVK) Pozrite si návod na inštaláciu

- (GB) Look/See
- (D) Schauen
- (E) Mirar
- (F) Verrouiller
- (I) Osservare
- (P) Ver
- (NL) Kijken
- (DK) Se
- (N) Se
- (S) Se
- (SF) Katso
- (CZ) Podívejte se
- (H) Nézze meg
- (PL) Spójrzec
- (GR) Κοιτάξτε
- (RUS) Контролировать визуально
- (SVK) Pozriť / Zobrazit



- (GB) Temporarily tightening
- (D) Provisorisch festziehen
- (E) Ajustar temporariamente
- (F) Serrage provisoire
- (I) Serrare temporaneamente
- (P) Aperto temporário
- (NL) Provisorisch aandraaien
- (DK) Midlertidig stramning
- (N) Midlertidig stramning
- (S) Temporär åtdragning
- (SF) Kiristä tilapäisesti
- (CZ) Dočasné zpevnění
- (H) Ideiglenes megszorítás
- (PL) Tymczasowe dokręcanie
- (GR) Προσωρινό σφίξιμο
- (RUS) Временная затяжка
- (SVK) Dočasné utiahnutie

- (GB) Use drill
- (D) Bohrer verwenden
- (E) Usar taladro
- (F) Utiliser une perceuse
- (I) Utilizzare il trapano
- (P) Utilizar broca
- (NL) Boor gebruiken
- (DK) Brug bor
- (N) Bruk bor
- (S) Använd borr
- (SF) Käytä poraa
- (CZ) Použijte vrtačku
- (H) Használjon fúrót
- (PL) Użyć wiertła
- (GR) Χρησιμοποιήστε τρυπάνι
- (RUS) Использовать дрель
- (SVK) Použite vrtačku

- (GB) Burr removal
- (D) Entgraten
- (E) Eliminador de rebaba
- (F) Retrait des ébarbures
- (I) Rimozione bave
- (P) Remoção da rebarba
- (NL) Bramen verwijderen
- (DK) Fjernelse af grat
- (N) Fjerning av gradkant
- (S) Avgradning
- (SF) Hio reunat
- (CZ) Odstranění hrubých okrajů
- (H) Forgács eltávolítása
- (PL) Usuwanie zadziórów
- (GR) Αφαίρεση ριγισμάτων
- (RUS) Удалить неровности
- (SVK) Odstránenie drsného okraja

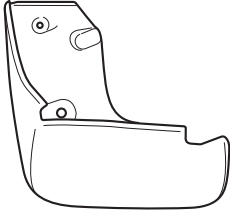
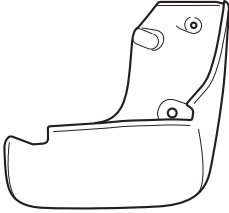
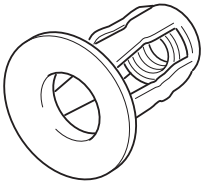
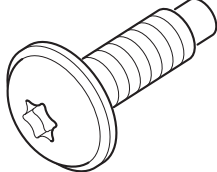
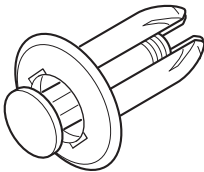
A	(LH)	B	(RH)
DESCRIPTION DFR5 V3 452 >TPE<		DESCRIPTION DFR5 V3 451 >TPE<	
 X 1		 X 1	
C			D
 X 4		 X 4	
E			
 X 4			

L+R

1

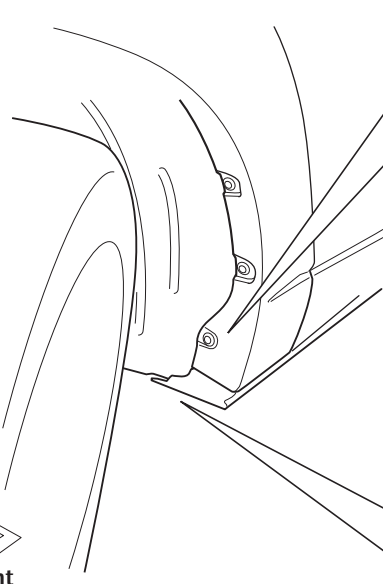

Front

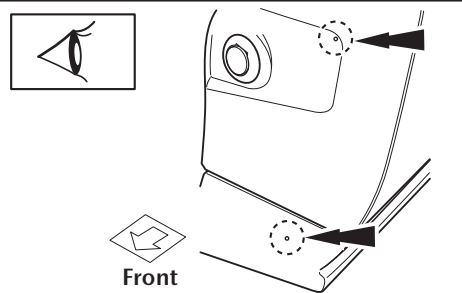

Front

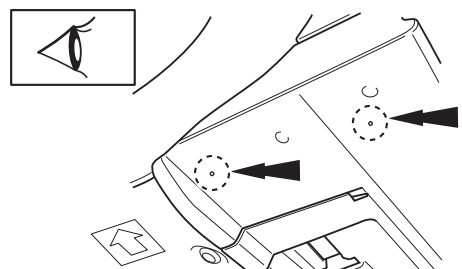

Front



φ1mm

0.5mm

4 X

L+R

2

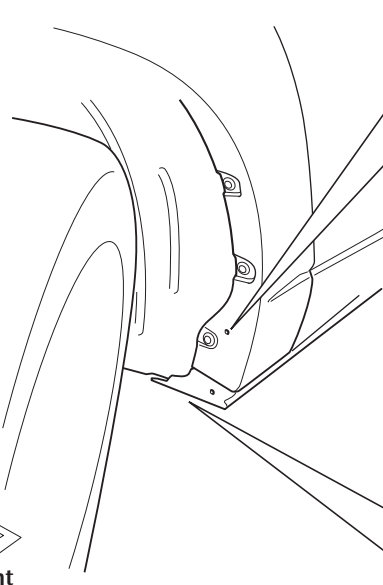

Front

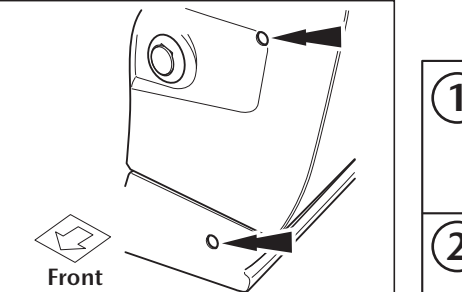

Front

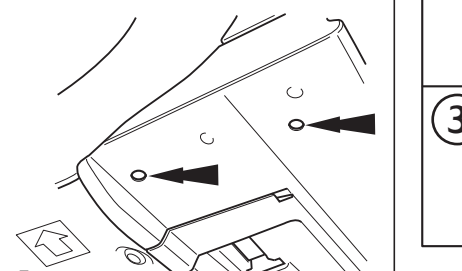

Front

1

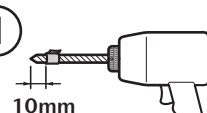

10mm

2

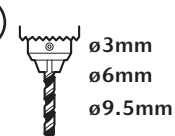

ø3mm
 ø6mm
 ø9.5mm

4 X

3

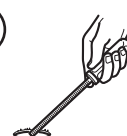

4 X

L+R

3

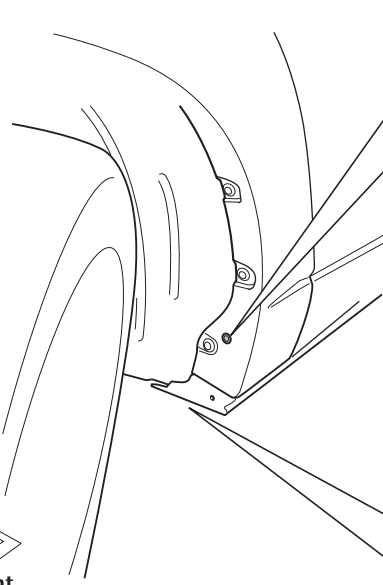

Front

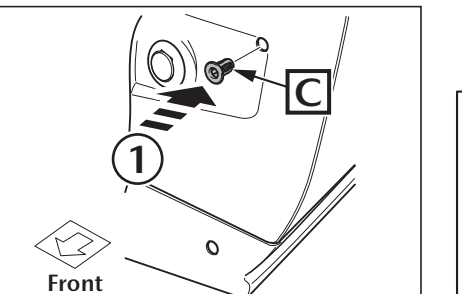

Front

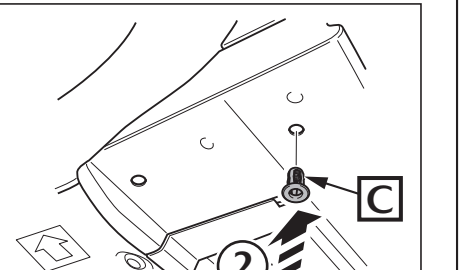

Front

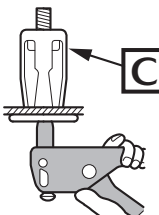
↓



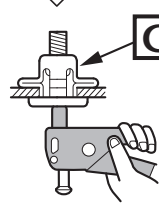

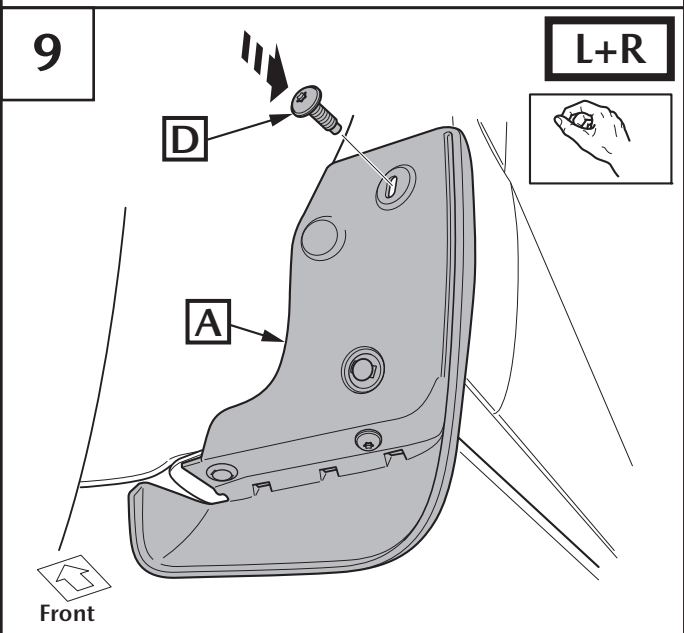
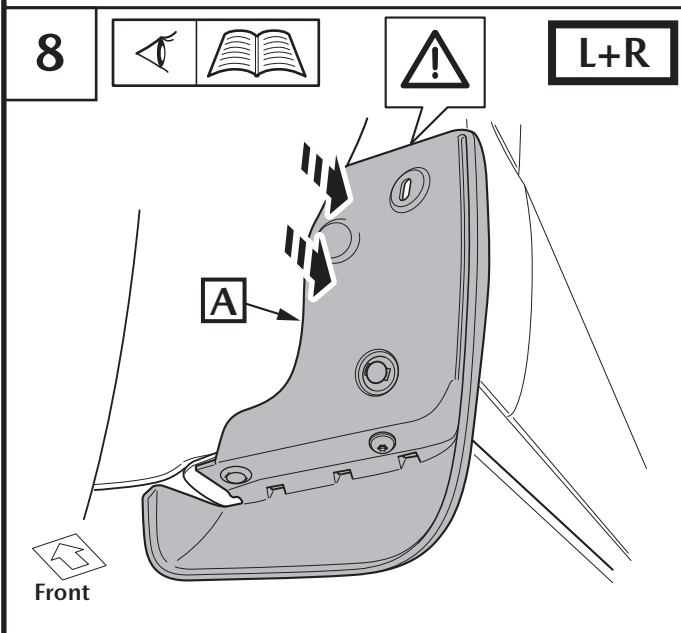
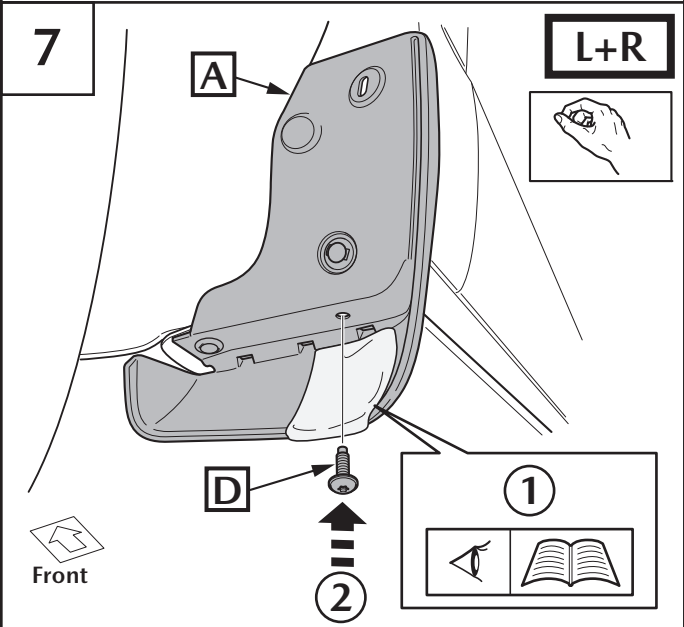
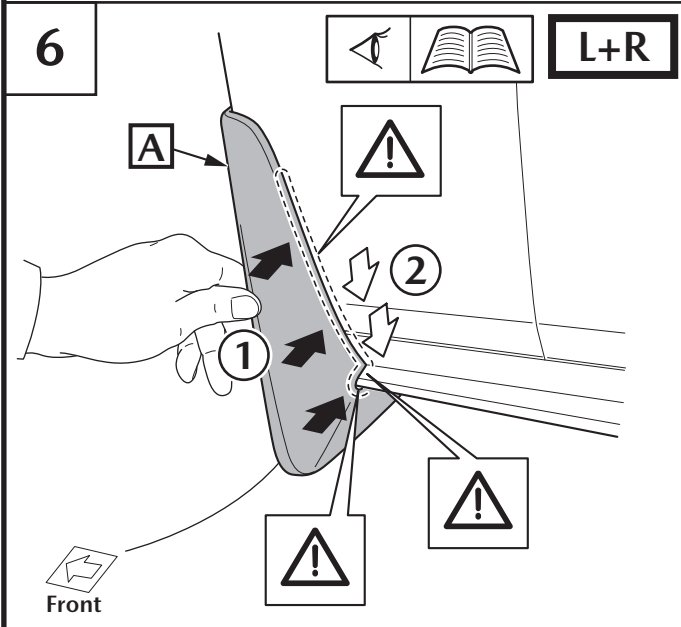
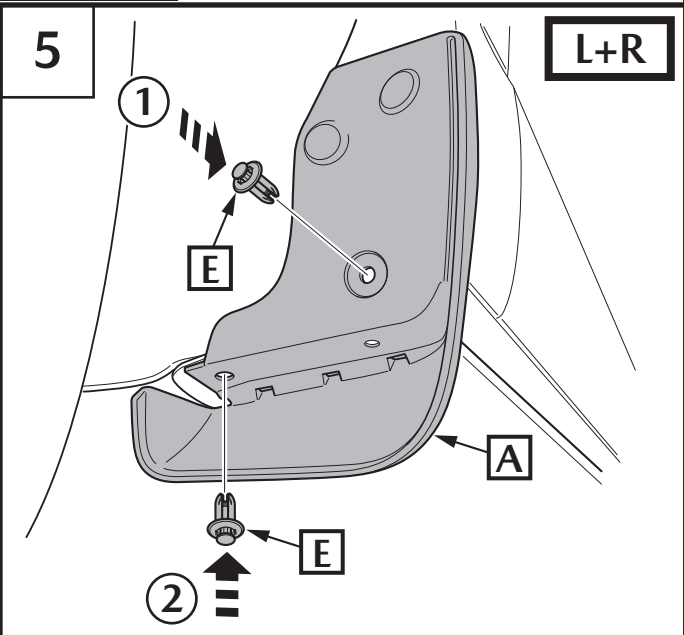
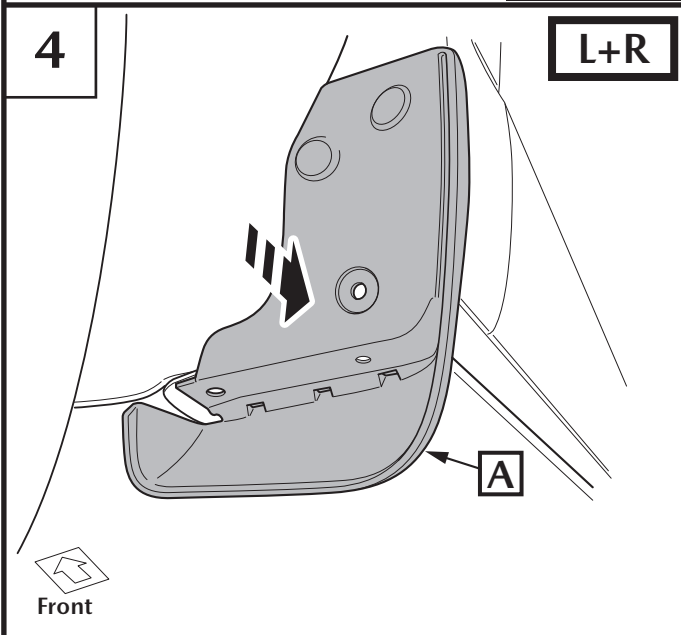
10

L+R

