

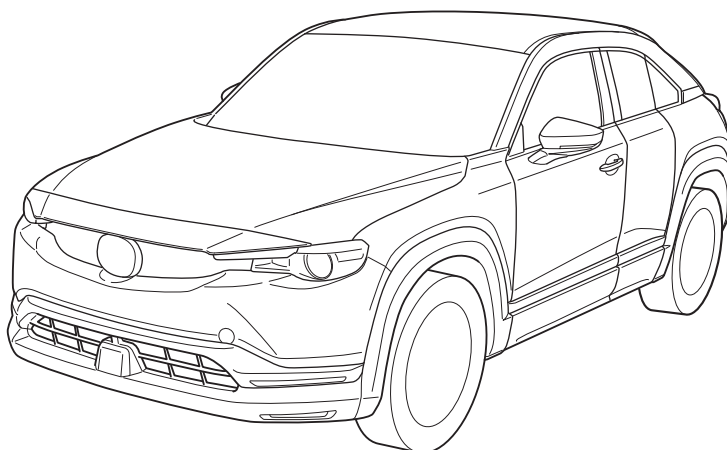

MAZDA

GB SCUFF PLATES (ILLUMINATED) Installation instruction	S INSTEGSLISTER (BELYSTA) Monteringsanvisning
D EINSTIEGSLEISTEN (BELEUCHTET) Einbauanleitung	SF KYNNYSLISTAT (VALAISTU) Asennusohje
E LISTONES DE UMBRAL (ILUMINADOS) Instrucciones de Montaje	CZ NASTUPNI LISTY (OSVĚTLENÉ) Návod k Montáži
F BASE DE PORTE (ÉCLAIRÉS) Instructions de Montage	H KÜSZÖBLÉCEK (MEGVILAGITVA) Beszerelési Utasítása
I BATTICALCAGNO (ILLUMINATI) Istruzioni di Montaggio	PL LISTWY PROGOWE (O WISTLONE) Instrukcja zabudowy
P EMBALADEIRAS (COM ILUMINAÇÃO) Instruções de Montagem	GR ΠΡΟΣΤΑΤΕΥΤΙΚΑ ΕΠΙΒΙΒΑΣΗΣ (ΦΩΤΙΣΜΕΝΑ) Οδηγίες τοποθέτησης
NL DREMPELFOLIES (VERLICHT) Inbouw-Instructie	RUS ВХОДНЫЕ ПЛАНКИ (ОСВЕЩАЕМЫЕ) Инструкцию по установке
DK INDSTIGNINGSLISTER (BELYST) Monteringsvejledning	SVK SKUFNE PLOŠČE (OSVETIJENE) Návod na inštaláciu
N STIGTRINN (MED LYS) Monteringsveiledning	



MAZDA MX-30

DR

Part No: DN4J V1 370

Date: 09-04-2020

© Copyrights MAZDA

Sheet 1 of 8

Expert Fitment Required
Montage durch Fachwerkstatt erforderlich
Montaje sólo por el concesionario
Montage par spécialiste nécessaire
E' necessario in officina specializzata
Especialista em montagem requerido
Montage door vakman nodig
Montage ved professionelt værksted påkrævet
Nødvendig med montering fra fagvejerksted
Verkstadsmontage erfordras
Asennus tarpeen merkkikorjaamossa
Montáž ve specializované dílně nutná
A szereléshez szakműhely kell
Konieczny montaż przez warsztat specjalistyczny
Να τοποθεί απο συνεργείο
Необходима установка специалистами
Vyžaduje sa odborné vybavenie



L+R

- (GB) Position arrow
- (D) Positionspfeil
- (E) Flecha de posición
- (F) Flèche de position
- (I) Freccia di posizione
- (P) Flexa de posição
- (NL) Lokatie/Positie pijl
- (DK) Lokaliseringspil
- (N) Posisjonspil
- (S) Positionpil
- (SF) Paikannusnuoli
- (CZ) Šipka na pozici
- (H) Helyzetjelző nyíl
- (PL) Strzałka położenia
- (GR) Βέλος θέσης
- (RUS) Стрелка расположения
- (SVK) Šipka polohy

- (GB) Movement arrow
- (D) Bewegungspfeil
- (E) Flecha de movimiento
- (F) Flèche de mouvement
- (I) Freccia di movimento
- (P) Flexa de movimento
- (NL) Richtingspijl
- (DK) Bevægelsespil
- (N) Bevegelsespil
- (S) Rörelsepil
- (SF) Liikesuuntanuoli
- (CZ) Šipka pohybu
- (H) Mozgásirányjelző nyíl
- (PL) Strzałka kierunku ruchu
- (GR) Βέλος κίνησης
- (RUS) Стрелка движения
- (SVK) Šipka pohybu

- (GB) Same procedure for the left and right side
- (D) Gleicher einbau für linke und rechte Seite
- (E) Mismo procedimiento para lado izquierdo y derecho
- (F) Procédure identique pour les côtés gauche et droit
- (I) Stessa procedura valida per il lato destro e sinistro
- (P) Mesmo procedimento para o lado esquerdo e direito
- (NL) Dezelfde procedure voor de linker en rechter zijde
- (DK) Samme fremgangsmåde for venstre og højre side
- (N) Samme prosedyre for venstre og høyre side
- (S) Samma åtgärd för vänster och höger sida
- (SF) Samat toimenpiteet vasemmalla ja oikealle puolelle
- (CZ) Postup je stejný pro levou i pravou stranu
- (H) Az eljárás azonos a bal és a jobb oldalon
- (PL) Te same czynności należy wykonać po lewej i prawej stronie
- (GR) Ίδια διαδικασία για την αριστερή και τη δεξιά πλευρά
- (RUS) Однаковая последовательность действий как для левой, так и для правой стороны
- (SVK) Rovnaký postup pre ľavú a pravú stranu



- (GB) Tape up
- (D) Mit Klebeband befestigen
- (E) Fijar con cinta adhesiva
- (F) Fixer avec ruban adhésif
- (I) Fissare con nastro adesivo
- (P) Sujeitar com fita adesiva
- (NL) Vastzetten met tape
- (DK) Fastgøres med tape
- (N) Fest fast med klebeband
- (S) Fästet med tejp
- (SF) Kiinnitys teipillä
- (CZ) Upevnit lepicí páskou
- (H) Rögzítse ragasztószalaggal
- (PL) Umocować taśmą samoprzylepną
- (GR) Στερέωση με κολλητική ταινία
- (RUS) Закрепите клейкой лентой
- (SVK) Páskou nahor

- (GB) Warning
- (D) Achtung
- (E) Atención
- (F) Attention
- (I) Attenzione
- (P) Atenção
- (NL) Let op
- (DK) Bemærk
- (N) Pass på
- (S) Varning
- (SF) Huomio
- (CZ) Pozor
- (H) Figyelem
- (PL) Uwaga
- (GR) Προσοχή
- (RUS) Осторожно
- (SVK) Výstraha

- (GB) Throw away
- (D) Entsorgen
- (E) Tratamiento de residuos
- (F) Rebuter
- (I) Smaltire
- (P) Eliminar
- (NL) Weggooien
- (DK) Affald
- (N) Avskaffe
- (S) Ta hand om avfallet
- (SF) Hävittää
- (CZ) Vyhodit
- (H) Távolítsa el
- (PL) Usunąć jako odpad
- (GR) Απόσυρση
- (RUS) Выбросите
- (SVK) Zahodit



CLEANER

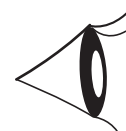

- (GB) Wipe clean
- (D) Reinigen
- (E) Limpiar
- (F) Nettoyer
- (I) Ripulire
- (P) Limpiar
- (NL) Zuiver maken
- (DK) Aftørring
- (N) Rengjøring
- (S) Rengör
- (SF) Puhdista
- (CZ) Očistit
- (H) Tisztítsa meg
- (PL) Oczyszczyć
- (GR) Καθαρίσματος
- (RUS) Протрите дочиста
- (SVK) Čistif utieraním

- (GB) See installation instructions
- (D) Siehe Installationsanleitung
- (E) Consulte las Instrucciones de instalación
- (F) Voir les instructions d'installation
- (I) Vedere le istruzioni di installazione
- (P) Veja as instruções de instalação
- (NL) Zie installatie-instructies
- (DK) Se monteringsvejledning
- (N) Se installeringsveiledningen
- (S) Se installationssanvisningarna
- (SF) Katso asennusohjeet
- (CZ) Viz instalační pokyny
- (H) Lásd a telepítési utasításokat
- (PL) Patrz instrukcja instalacji
- (GR) Βλέπε οδηγίες εγκατάστασης
- (RUS) См. инструкции по установке
- (SVK) Pozrite si návod na inštaláciu

- (GB) Look/See
- (D) Siehe
- (E) Ver
- (F) Voir
- (I) Vedere
- (P) Cf.
- (NL) Kijken naar
- (DK) Se
- (N) Se
- (S) Se
- (SF) Katso
- (CZ) Viz
- (H) Lásd
- (PL) Patrz
- (GR) βλέπε
- (RUS) См.
- (SVK) Pozriet/Zobrazit

A (RH)
DESCRIPTION

 DN4J V1 370
>PC<

(Lithium CR 2025 X2) 1x

B (LH)
DESCRIPTION

 DN4J V1 370
>PC<

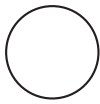
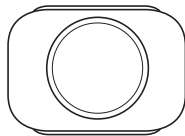

(Lithium CR 2025 X2) 1x

C
(1)

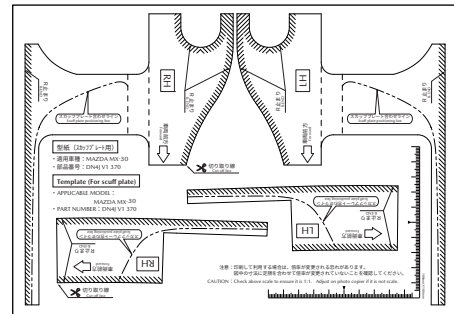
(2)

2x

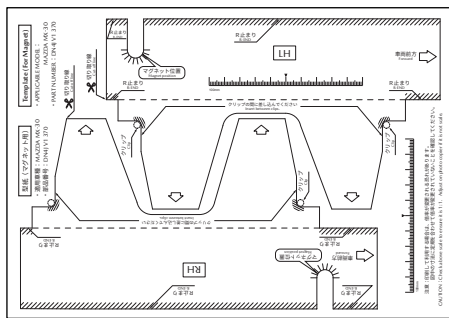
D

For scuff plate 1x

E

For magnet 1x



1

L+R

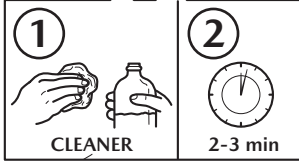
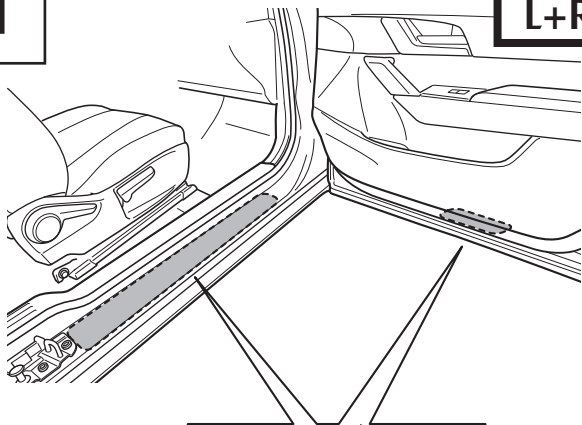

2

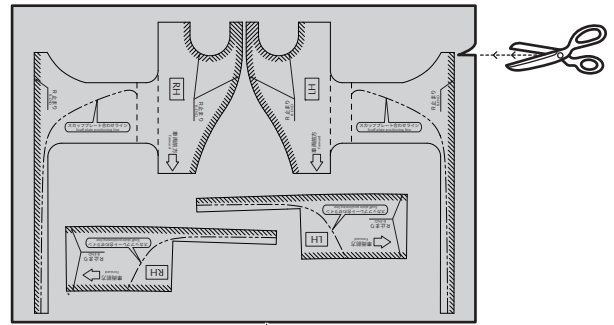

D

(For scuff plate)

3

L+R

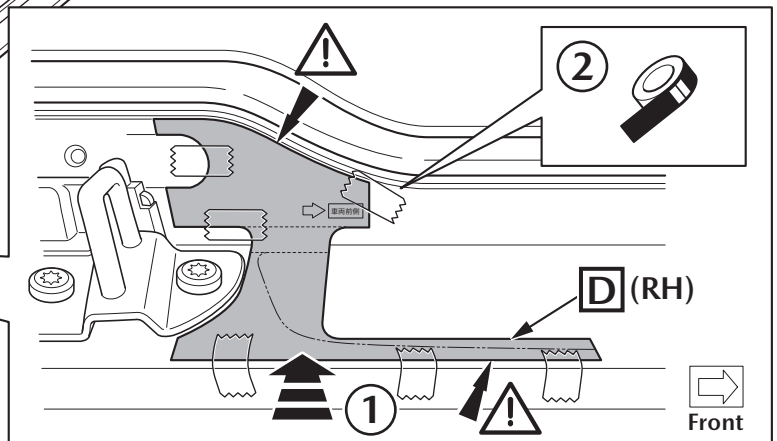
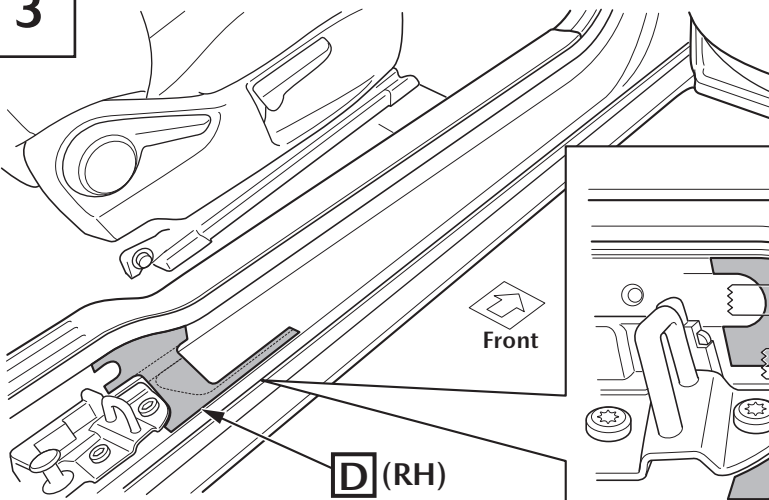

4

L+R

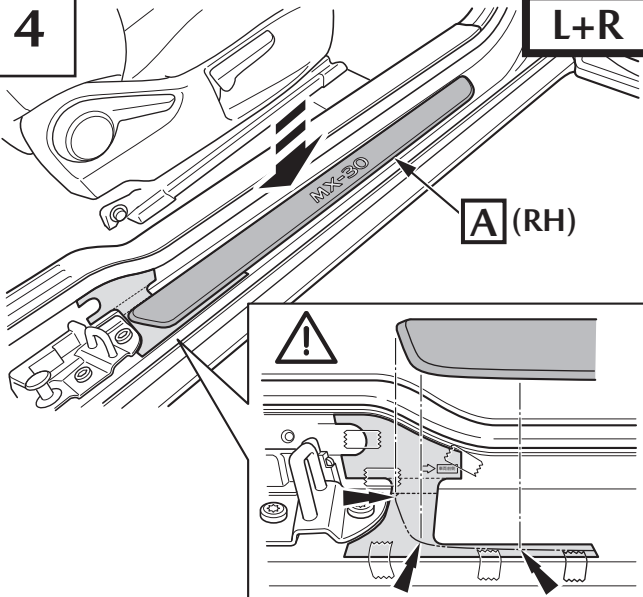

5

L+R

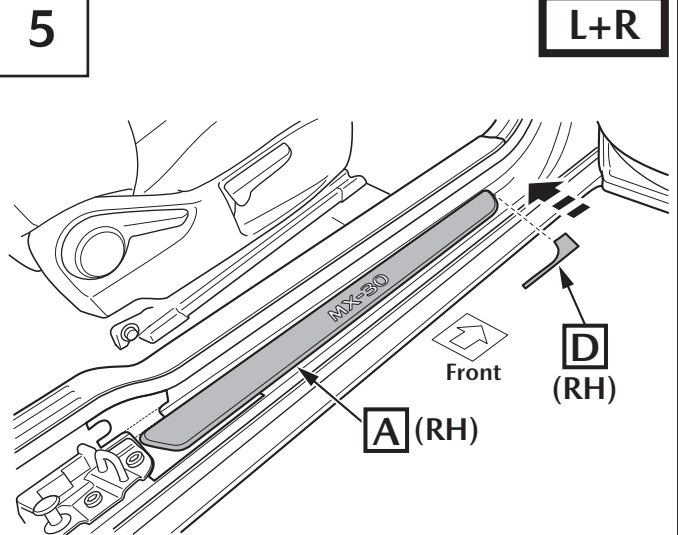



6

L+R

A (RH)

D (RH)

Front

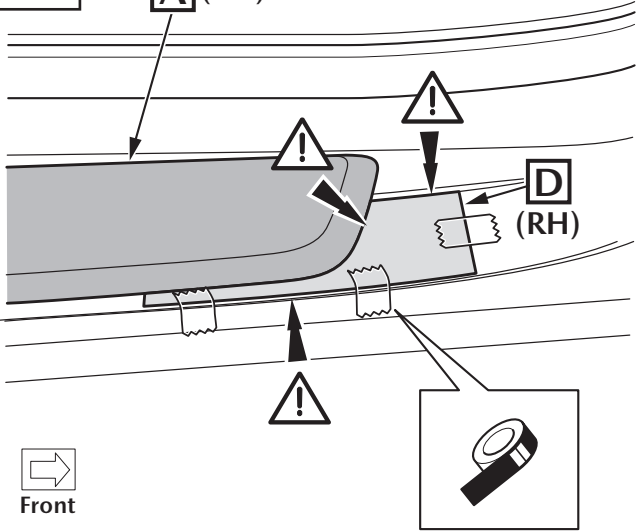

7

L+R

A (RH)

Front

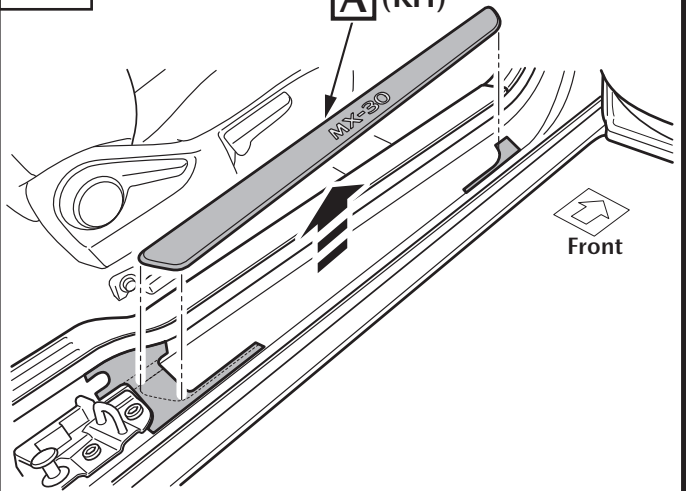

8

L+R

A (RH)

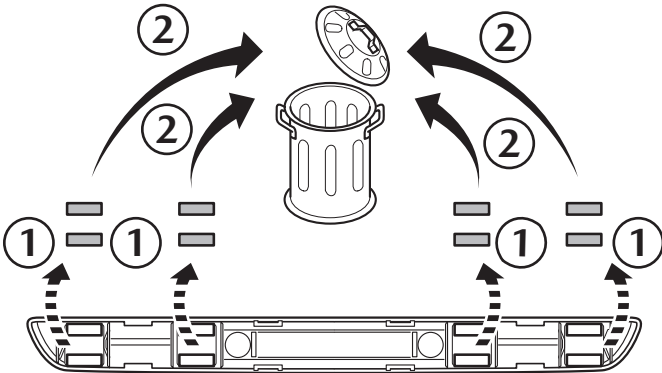

9

L+R

A (RH)

Front

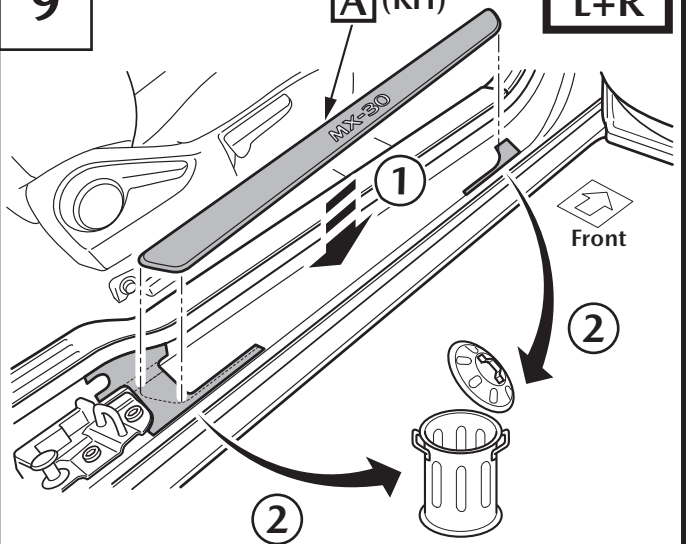

10

L+R

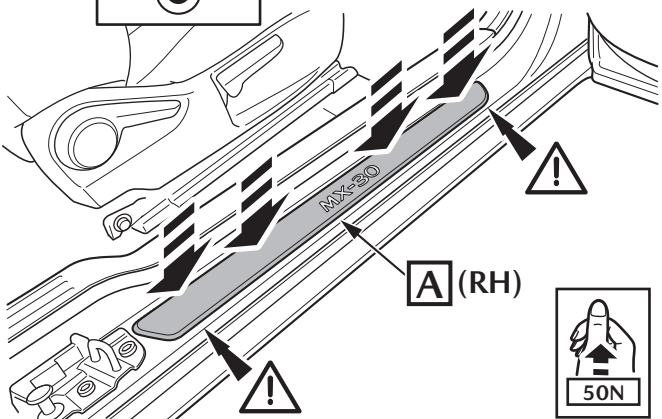
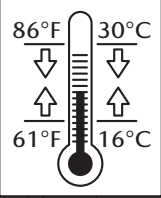

11

(For magnet)

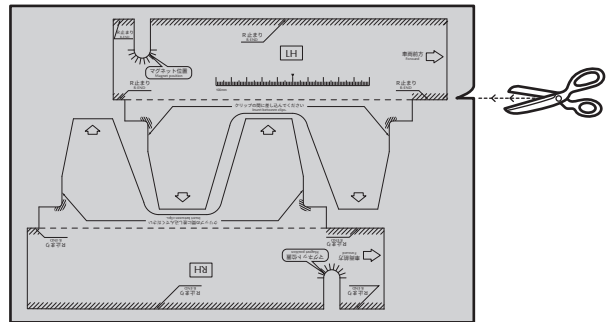



12

L+R

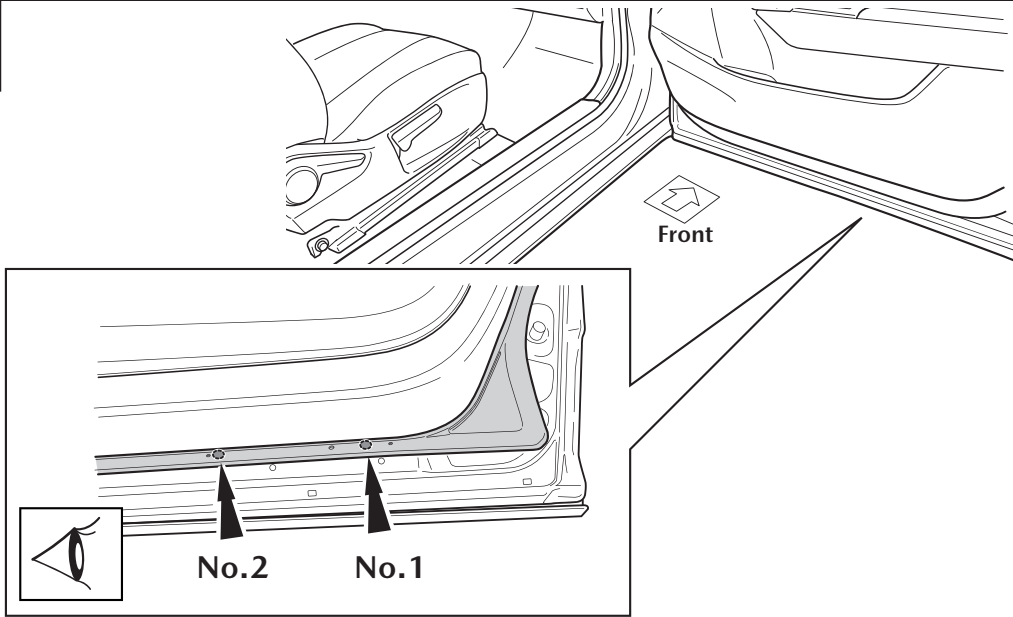

13

L+R

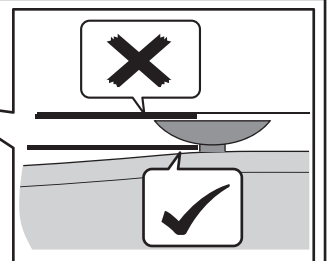
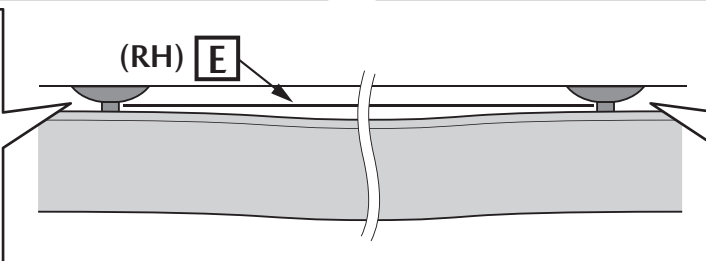
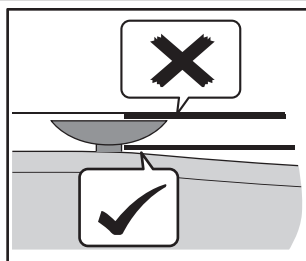
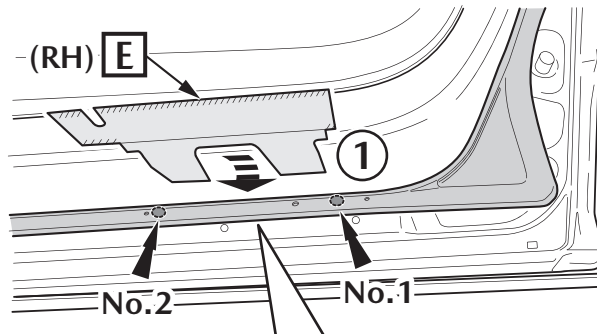

14

L+R

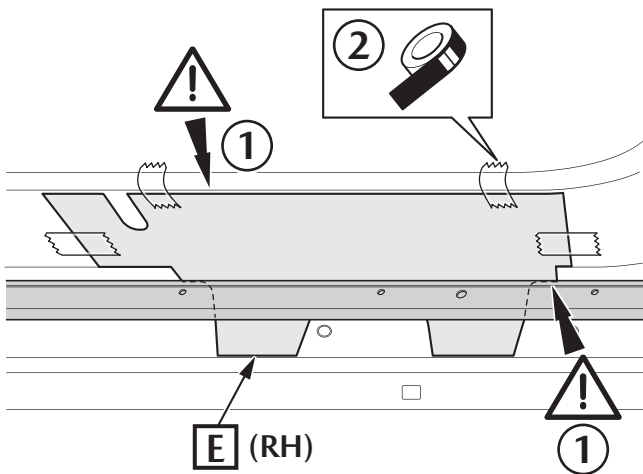

15

L+R

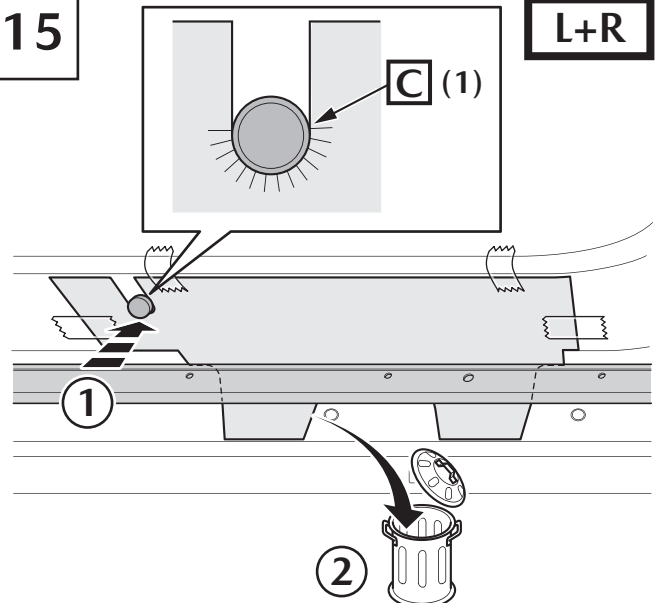

16

L+R

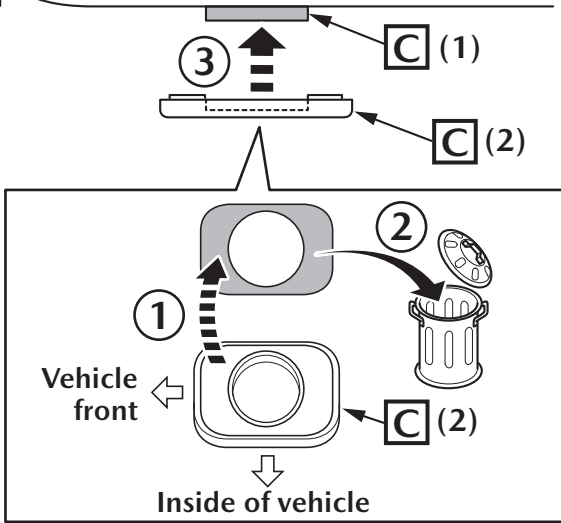

17

L+R

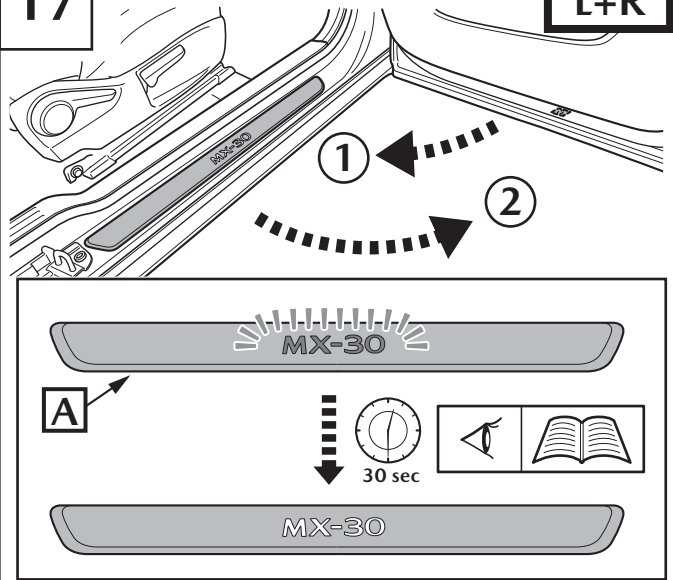

18

L+R

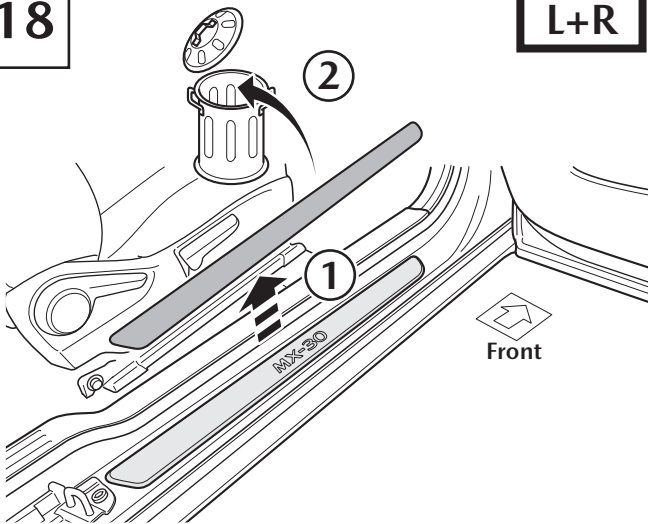

19



Lithium CR 2025 x 2

L+R





20

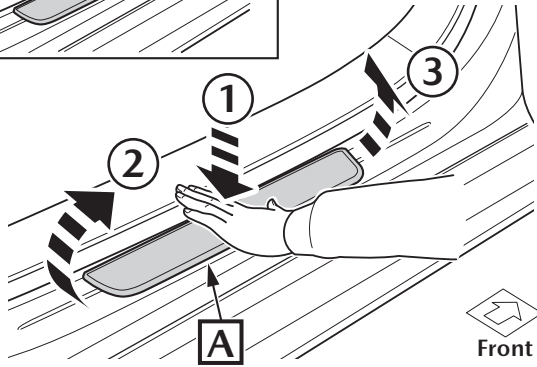
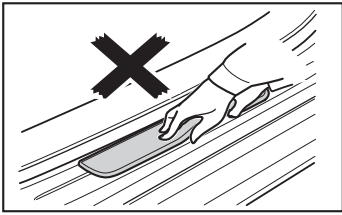

21

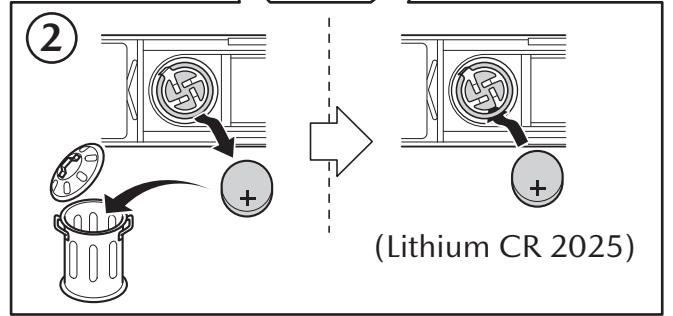
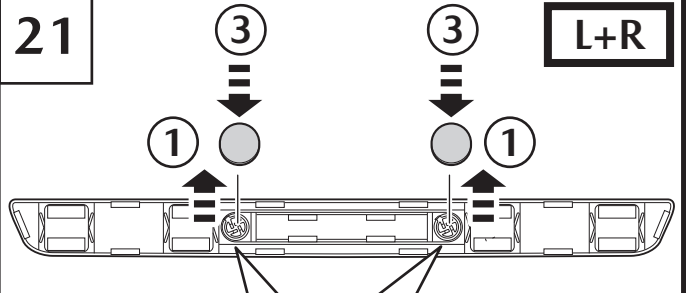

22

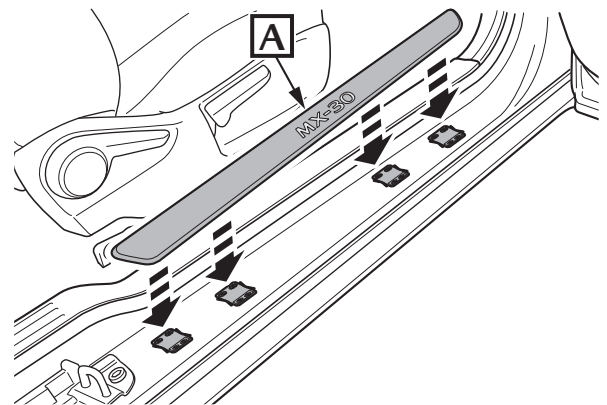
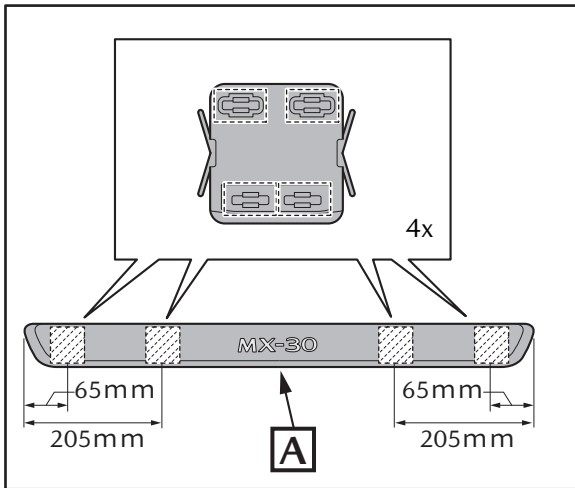

23

