

MAZDA

GB	REAR VIEW CAMERA Installation Instruction
D	RÜCKFAHRKAMERA Einbauanleitung
E	CAMARA DE MARCHA ATRAS Instrucciones de montaje
F	CAMERA DE VUE ARRIÈRE Instructions de montage
I	TELECAMERA RETROVISORE Istruzioni di montaggio
P	CAMERA TRASEIRA DAVISTA Instruções de montagem
NL	ACHTERUITRIJKAMERA Inbouw-instructie
DK	BAKKAMERA Monteringsvejledning

N	RYGGEKAMERA Monteringsvejledning
S	BAKKAMERA Monteringsanvisning
SF	PERUUTUSKAMERA Asennusohje
CZ	KAMERA PRO COUVANÍ Návod k montáži
H	TOLATÓ KAMERA Beszerelési utasítás
PL	KAMERA COFANIA Instrukcja montażu
GR	ΚΑΜΕΡΑ ΟΠΙΣΘΟΠΟΡΕΙΑΣ Οδηγίες τοποθέτησης
RUS	КАМЕРА ЗАДНЕГО ОБЗОРА инструкция по установке

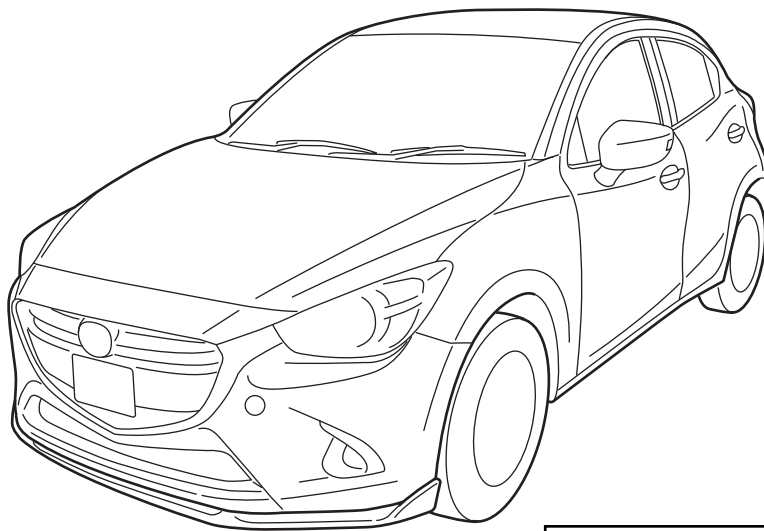

MAZDA 2 | DJ1

Part Number: DC3M-V7-535

Date: 05-02-2015

© Copyright MAZDA

Sheet 1 of 19

DC3M-V7-535-05022015

Expert Fitment Required
Montage durch Fachwerkstatt erforderlich
Montaje sólo por el concesionario
Montage par spécialiste nécessaire
E' necessario in officina specializzata
Especialista em montagem requerido
Montage door vakman nodig
Montage ved professionelt værksted påkrævet
Nødvendig med montering fra fagvejværksted
Verkstadsmontage erfordras
Asennus tarpeen merkkikorjaamossa
Montáž ve specializované dílně nutná
A szereléshez szakműhely kell
Konieczny montaż przez warsztat specjalistyczny
Να τοποθεί απο συνεργείο
Необходима установка специалистами

Mazda Color Table

	GB	D	E	F	I	P	NL	DK
B	Black	Schwarz	Negro	Noir	Nero	Preto	Zwart	Sort
BE	Beige	Beige	Beige	Beige	Beige	Bege	Beige	Beige
BR	Brown	Braun	Marrón	Marron	Marrone	Castanho	Bruin	Brun
DG	Dark green	Dunkelgrün	Verde oscuro	Vert foncé	Verde scuro	Verde-escuro	Donkergroen	Mørkegrøn
DL	Dark blue	Dunkelblau	Azul oscuro	Bleu foncé	Blu scuro	Azul-escuro	Donkerblauw	Mørkeblå
G	Green	Grün	Verde	Vert	Verde	Verde	Greon	Grøn
GY	Grey	Grau	Gris	Gris	Grigio	Cinzeno	Grijs	Grå
L	Blue	Blau	Azul	Bleu	Blu	Azul	Blauw	Blå
LB	Light blue	Hellblau	Azul claro	Bleu clair	Blu chiaro	Azul-claro	Lichtblauw	Lyseblå
LG	Light green	Hellgrün	Verde claro	Vert clair	Verde chiaro	Verde-claro	Lichtgroen	Lysegrøn
N	Natural colour	Naturfarbe	Color natural	Nature	Colori naturali	Cores naturais	Naturel	Naturfarvet
O	Orange	Orange	Naranja	Orange	Arancione	Laranja	Oranje	Orange
P	Pink	Rosa	Rosa	Rose	Rosa	Rosa	Rosé	Rosa
PU	Purple	Purpur	Púrpura	Pourpre	Rosso porpora	Púrpura	Paars	Purpur
R	Red	Rot	Rojo	Rouge	Rosso	Vermelho	Rood	Rød
SB	Sky blue	Himmelblau	Azul cielo	Bleu ciel	Celeste	Azul-céu	Hemelsblauw	Himmelblå
T	Yellow brown	Gelbbraun	Amarillo-marrón	Marron-jaune	Giallomarrone	Castanho-amarelado	Geelbruin	Gulbrun
V	Violet	Violett	Violeta	Violet	Viola	Violeta	Violet	Violet
W	White	Wei	Bianco	Blanc	Bianco	Branco	Wit	Hvid
Y	Yellow	Gelb	Amarillo	Jaune	Giallo	Amarelo	Geel	Gul

	N	S	SF	CZ	H	PL	GR	RUS
B	Sort	Svart	Musta	ern	Fekete	Czarna	Μαύρο	ёрный
BE	Beige	Beige	Beige	Beige	bzov	beowy	Μπεζ	бежевый
BR	Brun	Brun	Ruskea	Hnd	Barna	Brazowa	Καφ	Коричневый
DG	Mørkegrønn	Mrkgrn	Tummanvihre	Tmavomodr	Sttzld	Ciemnozielona	Σκούρο πράσινο	Тёмно-зелный
DL	Mørkebl	Mrkbl	Tummansininen	Tmavomodr	Sttkk	Granatowa	Σκούρο μπλε	Тёмно-синий
G	Grnn	Grn	Vihre	Zelen	Zld	Zielona	Πράσινο	Зелный
GY	Gr	Gr	Harmaa	ed	Szrke	Szara	Γκρι	Серый
L	Bl	Bl	Sininen	Modr	Kk	Niebieska	Μπλε	Синий
LB	Lysebl	Ljusbl	Vaaleansininen	Bledmodr	Vilgoskk	Jasnoniebieska	Ανοικτ μπλε	Голубой
LG	Lysegrnn	Ljusgrn	Vaaleanvihre	Svtlezelen	Vilgoszld	Jasnozielona	Ανοικτ πράσινο	Светло-зелный
N	Naturfarger	Naturfrger	Luonnonvri	Prodn barva	Termszetes szn	Barwy naturalne	Φυσικ χροκαλ	Телесный
O	Orange	Orange	Oranssi	Oranov	Narancs	Pomaraczowa	Πορφυρο	Оранжевый
P	Rosa	Rosa	Rosa	Rov	Rzsaszn	Rzowa	Ροζ	Розовый
PU	Purpur	Pur Pur	PurPurra	Purpurov	Bborvrs	Purpurowa	Πορφυρο	Пурпурный
R	Rd	Rd	Punainen	erven	Piros	Czerwona	Κόκκινο	Красный
SB	Himmelbl	Himmelsbl	Taivaansininen	Blankyt	gsznkk	Bkitna	Γαλζιο	Небесно-голубой
T	Gulbrun	Gulbrun	Keltaisenrus- kea	lutohnd	Srgsbarna	Zltobrazowa	Κίτρινοκαφ	Жлто-коричневый
V	Fiolett	Violett	Violett	Fialov	Ibolyakk	Fioletowa	Μοβν	ФйФиолетовый
W	Hvid	Vit	Valkionen	Bil	Fehr	Biaa	Λευκ	Белый
Y	Gul	Gul	Keltainen	lut	Srga	Zlta	Κίτρινο	Жлтый



- (GB)** Movement Arrow
- (D)** Bewegungspfeil
- (E)** Flecha de movimiento
- (F)** Flèche indiquant sens du vouvement
- (I)** Freccia di movimentov
- (P)** Flexa de movimento
- (NL)** Richtingspijl
- (DK)** Bevægelsespil
- (N)** Bevegelsespil
- (S)** Rörelsepil
- (SF)** Liikesuuntanuoli
- (CZ)** Šipka pohybu
- (H)** Mozgásirányjelző nyíl
- (PL)** Strzałka kierunku ruchu
- (GR)** Βέλος κίνησης
- (RUS)** Стрелка по направлению



- (GB)** See Workshop Manual
- (D)** Siehe Werkstatthandbuch
- (E)** Ver manual de taller
- (F)** Voir Manuel d'atelier
- (I)** Vedere manuale officina
- (P)** Cf. o manual da oficina
- (NL)** Zie werkplaatshandboek
- (DK)** Se værktstedshåndbog
- (N)** Se verkstedshåndboka
- (S)** Se verkstadshandboken
- (SF)** Katso korjaamon käsikirjasta
- (CZ)** Viz dílenskou příručku
- (H)** Lásd a Műhely-kézikönyvben
- (PL)** Patrz podręcznik warsztatowy
- (GR)** λέπε Εγχειρίδιο Συνεργείου
- (RUS)** Смотри руководство для мастерской



- (GB)** Refer to specific view
- (D)** Siehe Abbildung
- (E)** Ver figura
- (F)** Cf. figure
- (I)** Vedi figura
- (P)** Cf. figura
- (NL)** Zie tekeningnummer
- (DK)** Se fig.
- (N)** Se bilde
- (S)** Se figur
- (SF)** Katso kuva
- (CZ)** Viz obrázek
- (H)** Lásd az ábrán
- (PL)** Patrz rysunek
- (GR)** Βλέπε Εικ
- (RUS)** Смотри соответствующую картинку



- (GB)** Disconnect
- (D)** Abklemmen
- (E)** Desconectar
- (F)** Déconnecter
- (I)** Staccare
- (P)** Desligar
- (NL)** Demonteren
- (DK)** Frakobles
- (N)** Klem av
- (S)** Koppla los
- (SF)** Irrota
- (CZ)** Odpojit
- (H)** Szakítsa meg, kapcsolja szét
- (PL)** Rozłączyć
- (GR)** Αποσύνδεση
- (RUS)** Разъедините



- (GB)** Connect
- (D)** Verbinden
- (E)** Conectar
- (F)** Connecter
- (I)** Collegare
- (P)** Ligar
- (NL)** In elkaar
- (DK)** Kobles
- (N)** Tilkopling
- (S)** Ansult
- (SF)** Yhdistä
- (CZ)** Spojit
- (H)** Kapcsolja össze
- (PL)** Połączyć
- (GR)** Σύνδεση
- (RUS)** Соедините



- (GB)** Warning
- (D)** Achtung
- (E)** Atención
- (F)** Attention
- (I)** Attenzione
- (P)** Atenção
- (NL)** Let op
- (DK)** Bemærk
- (N)** Pass på
- (S)** Varning
- (SF)** Huomio
- (CZ)** Pozor
- (H)** Figyelem
- (PL)** Uwaga
- (GR)** Προσοχή
- (RUS)** Осторожно



- (GB)** Degrease
- (D)** Entfetten
- (E)** Desengrasar
- (F)** Dégraisser
- (I)** Sgrassare
- (P)** Desengordurar
- (NL)** Ontvetten
- (DK)** Fjerne fedt
- (N)** To bort fettet
- (S)** Avfettning
- (SF)** Rasvanpoisto
- (CZ)** Odmastit
- (H)** Zsírtalanítás
- (PL)** Odtłuścić
- (GR)** Απολίπανση
- (RUS)** Обезжирьте

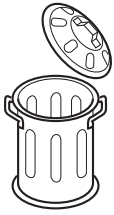

- (GB)** Throw away
- (D)** Entsorgen
- (E)** Tratamiento de residuos
- (F)** Jeter aux déchets
- (I)** Smaltire
- (P)** Eliminar
- (NL)** Weggoaien
- (DK)** Affald
- (N)** Avskaffe
- (S)** Ta hand om avfallet
- (SF)** Hävittää
- (CZ)** Vyhodit
- (H)** Távolítsa el
- (PL)** Usunąć jako odpad
- (GR)** Απόσυρση
- (RUS)** Выбросите

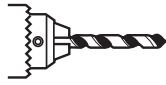

- (GB)** Use Drill
- (D)** Bohrer verwenden
- (E)** Utilizar broca
- (F)** Utiliser une mèche
- (I)** Utilizzare trapano
- (P)** Utilizar a perfuradora
- (NL)** Boordiameter
- (DK)** Bor anvendes
- (N)** Bruk diameter
- (S)** Använd borrh
- (SF)** Käytä poraa
- (CZ)** Použít vrták
- (H)** Használjon fúrót
- (PL)** Stosować wiertarkę
- (GR)** Χρησιμοποιείτε τρυπάνι
- (RUS)** Используйте дрель

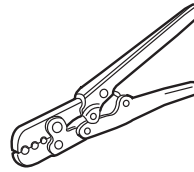

- (GB)** Use Crimping Tool
- (D)** Kabelschuhzange verwenden
- (E)** Utilizar alicates para terminales de cables
- (F)** Use pince pour broches de câble
- (I)** Utilizzare pinza per capocorda
- (P)** Sujeitar com fita adesiva
- (NL)** Kabelschoentang
- (DK)** Kabelskotang anvendes
- (N)** Bruk kabelskotang
- (S)** Använd kabelskotång
- (SF)** Käytä kaapelikenkäpihtejä
- (CZ)** Použít kleště na kabelová oka
- (H)** Használjon kábelsarufogót
- (PL)** Stosować cęgi do końcówek kablowych
- (GR)** Χρησιμοποιείτε πένσα πέδιλων αλωδίων
- (RUS)** Используйте щипцы с кабельным наконечником



- (GB)** Location/Position Arrow
- (D)** Positionspfeil
- (E)** Flecha de posición
- (F)** Flèche de Position
- (I)** Freccia di posizione
- (P)** Flexa de posição
- (NL)** Lokatie/Positie pijl
- (DK)** Lokaliseringspil
- (N)** Posisjonspil
- (S)** Positionpil
- (SF)** Paikannusnuoli
- (CZ)** Šipka na pozici
- (H)** Helyzetjelző nyíl
- (PL)** Strzałka położenia
- (GR)** Βέλος θέσης
- (RUS)** Позиция



- (GB)** Tape up
- (D)** Mit Klebeband befestigen
- (E)** Fijar con cinta adhesiva
- (F)** Fixer avec ruban adhésif
- (I)** Fissare con nastro adesivo
- (P)** Sujeitar com fita adesiva
- (NL)** Vastzetten met tape
- (DK)** Fastgøres med tape
- (N)** Fest fast med klebeband
- (S)** Fästet med tejp
- (SF)** Kiinnitys teipillä
- (CZ)** Upevnit lepicí páskou
- (H)** Rögzítse ragasztószalaggal
- (PL)** Umocować taśmą samoprzylepną
- (GR)** Στερέωση με κολλητική ταινία
- (RUS)** Прикрепите клейкой лентой



- (GB)** Tighten
- (D)** Festdrehen
- (E)** Apretar fuerte girando
- (F)** Bien serrer
- (I)** Stringere bene
- (P)** Apertar bem
- (NL)** Vastdraaien
- (DK)** Tilspændes
- (N)** Drei fast
- (S)** Dra fast
- (SF)** Kiristä tiukalle
- (CZ)** Utáhnout
- (H)** Feszesen csavarja be
- (PL)** Silnie dokręcić
- (GR)** Περιοτροφή γερά
- (RUS)** Закрытите



- (GB)** Use Scissors
- (D)** Schere verwenden
- (E)** Utilizar tijeras
- (F)** Utiliser des ciseaux
- (I)** Utilizzare forbice
- (P)** Utilizar serra
- (NL)** Gebruik Schaar
- (DK)** Saks anvendes
- (N)** Bruk saks
- (S)** Använd sax
- (SF)** Käytä saksia
- (CZ)** Použít nůžky
- (H)** Használjon ollót
- (PL)** Stosować nożyce
- (GR)** Χρησιμοποιείτε αλίδ
- (RUS)** Использовать ножницы



- (GB)** Make Wire Tool
- (D)** Metalldraht verwenden
- (E)** Utilizar alambre metálico
- (F)** Utiliser un fil métallique
- (I)** Utilizzare filo metallico
- (P)** Utilizar fio de metal
- (NL)** Gebruik metaaldraad
- (DK)** Metaltråd anvendes
- (N)** Bruk metalltråd
- (S)** Använd metalltråd
- (SF)** Käytä metallilankaa
- (CZ)** Použít kovový drát
- (H)** Használjon fémdrót
- (PL)** Stosować drut metalowy
- (GR)** Χρησιμοποιείτε μεταλλικό σύρμα
- (RUS)** Использовать металлическую проволоку



- (GB)** Pierce with Sharp Implement
- (D)** Dorn verwenden
- (E)** Utilizar punzòn
- (F)** Utiliser un mandrin
- (I)** Utilizzare mondrilo
- (P)** Utilizar mandril
- (NL)** Priem
- (DK)** Syl anvendes
- (N)** Bruk syl
- (S)** Använd dorn
- (SF)** Käytä tuurnaa
- (CZ)** Použít trn
- (H)** Használjon tüskét
- (PL)** Stosować przebijak
- (GR)** Χρησιμοποιείτε στυλέα
- (RUS)** Использовать пробойник



- (GB)** Cut with Craft Knife
- (D)** Mit Messer ausschneiden
- (E)** Recortar con cuchillo
- (F)** Récouper avec couteau
- (I)** Ritagliare con coltello
- (P)** Cortar
- (NL)** Wegsnijden
- (DK)** Udkæres med kniv
- (N)** Skjær ut med kniv
- (S)** Skär ut med kniv
- (SF)** Leikkaa irti veitsellä
- (CZ)** Vyříznout nožem
- (H)** Vágja ki késsel
- (PL)** Wyciąć nożem
- (GR)** Κοπή με μαχαίρι
- (RUS)** Вырезать ножом

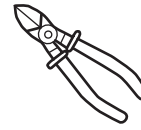

- (GB)** Use Wire Cutters
- (D)** Zange verwenden
- (E)** Utilizar alicates
- (F)** Utiliser pince
- (I)** Utilizzare pinza
- (P)** Utilizar pinca
- (NL)** Doorknippen
- (DK)** Tang anvendes
- (N)** Bruk tang
- (S)** Använd tång
- (SF)** Käytä pihtejä
- (CZ)** Použít kleště
- (H)** Használjon fogót
- (PL)** Stosować obcęgi
- (GR)** Χρησιμοποιείτε πέτσες
- (RUS)** Использовать клещи

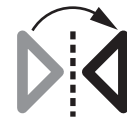

- (GB)** Mirror image
- (D)** Spiegelbild
- (E)** Imagen simétrica
- (F)** Image de miroir
- (I)** Immagine dello specchio
- (P)** Imagem do espelho
- (NL)** Mirror beeld
- (DK)** Spejlbillede
- (N)** Speilbilde
- (S)** Spegelbild
- (SF)** Peilikuva
- (CZ)** Věrný obraz
- (H)** Tükürkép
- (PL)** Odbicie lustrzane
- (GR)** εικ ανακρεφτών
- (RUS)** Зеркальное отражение



- (GB)** Correct
- (D)** Richtig
- (E)** Correcto
- (F)** Correct
- (I)** Giusto
- (P)** Certo
- (NL)** Goed
- (DK)** Rigtig
- (N)** Riktig
- (S)** Rätt
- (SF)** Oikein
- (CZ)** Správně
- (H)** Helyes
- (PL)** Prawidłowo
- (GR)** Σωστό
- (RUS)** Правильно



- (GB)** Incorrect
- (D)** Falsch
- (E)** Erróneo
- (F)** Incorrect
- (I)** Sbagliato
- (P)** Errado
- (NL)** Fout
- (DK)** Forkert
- (N)** Feilt
- (S)** Fel
- (SF)** Väärin
- (CZ)** Špatně
- (H)** Helyes
- (PL)** Nieprawidłowo
- (GR)** Λάθος
- (RUS)** Неправильно



- (GB)** Mark with Pencil
- (D)** Mit Bleistift anzeichnen
- (E)** Marcar con lápiz
- (F)** Marquer avec crayon
- (I)** Segnare con matita
- (P)** Marcar con lápiz
- (NL)** Aftekenen
- (DK)** Notér med blyant
- (N)** Pâtegne
- (S)** Rita upp med blyertspenna
- (SF)** Merkitse lyijykynällä
- (CZ)** Naznačit tužkou
- (H)** Rajzolja be ceruzával
- (PL)** Zaznaczyć ołówkiem
- (GR)** Σημαδεμα/Σχεδιασμός με μολύβι
- (RUS)** Отметить карандашом



- (GB)** Use File
- (D)** Feile verwenden
- (E)** Utilizar lima
- (F)** Utiliser lime
- (I)** Utilizzare lima
- (P)** Utilizar lima
- (NL)** Vijl
- (DK)** Fil anvendes
- (N)** Bruk fil
- (S)** Använd fil
- (SF)** Käytä viilaa
- (CZ)** Použít pilník
- (H)** Használjon reszelőt
- (PL)** Stosować pilnik
- (GR)** Χρησιμοποιείτε λίμα
- (RUS)** Использовать напильник

A

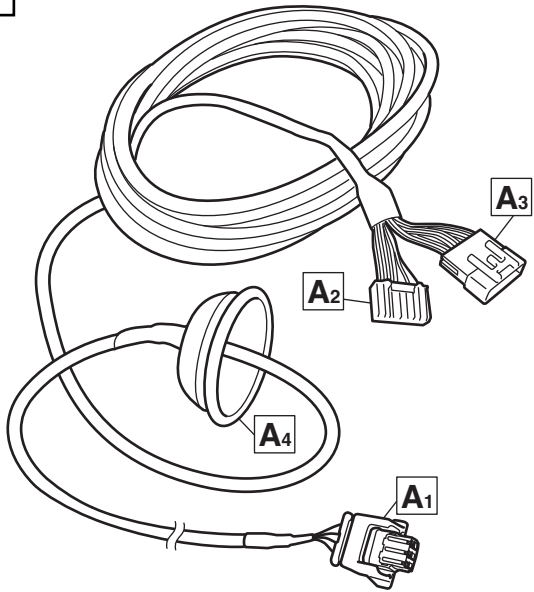

DC3M-V7-531

1x

B

D09H-67-RC0

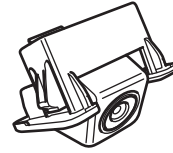

1x

C

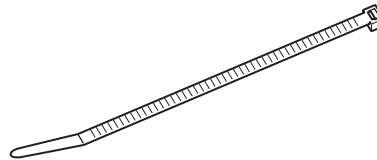

17x



i
Info

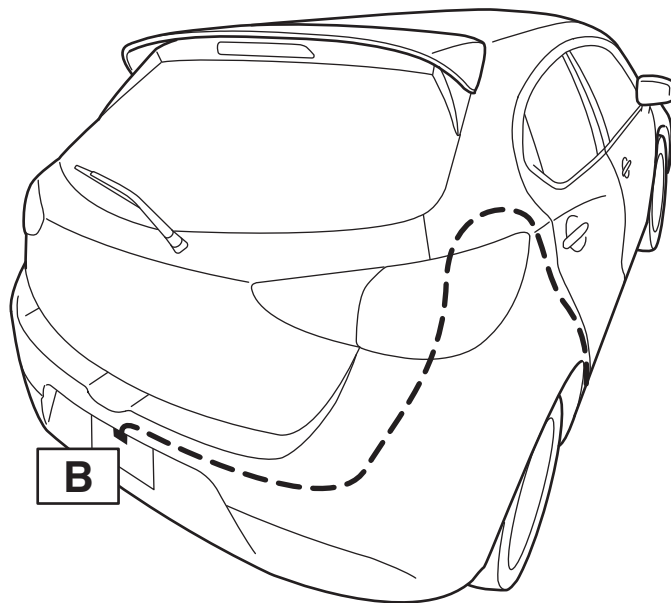
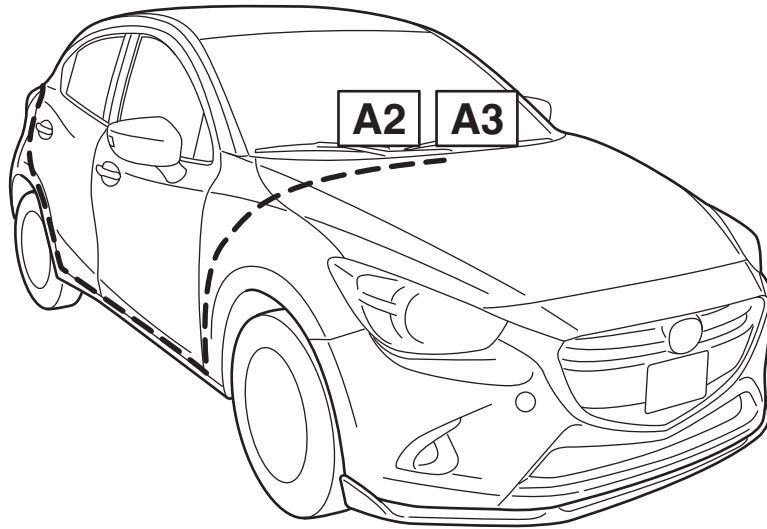

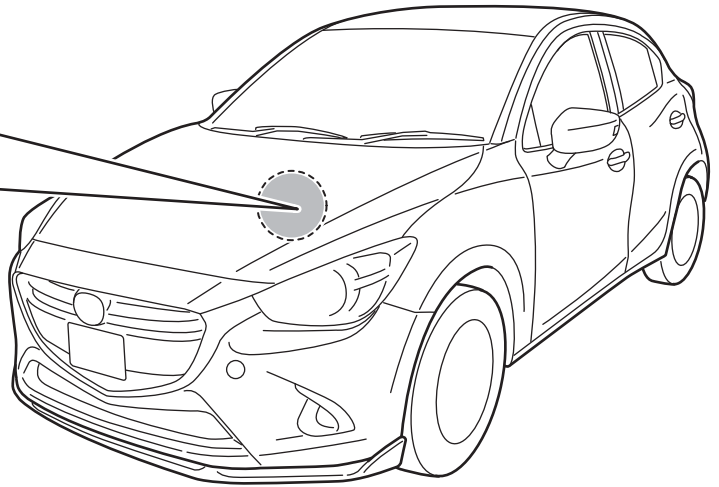
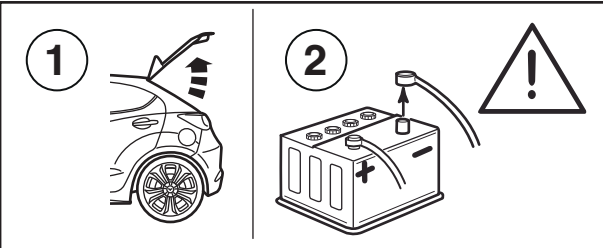

1

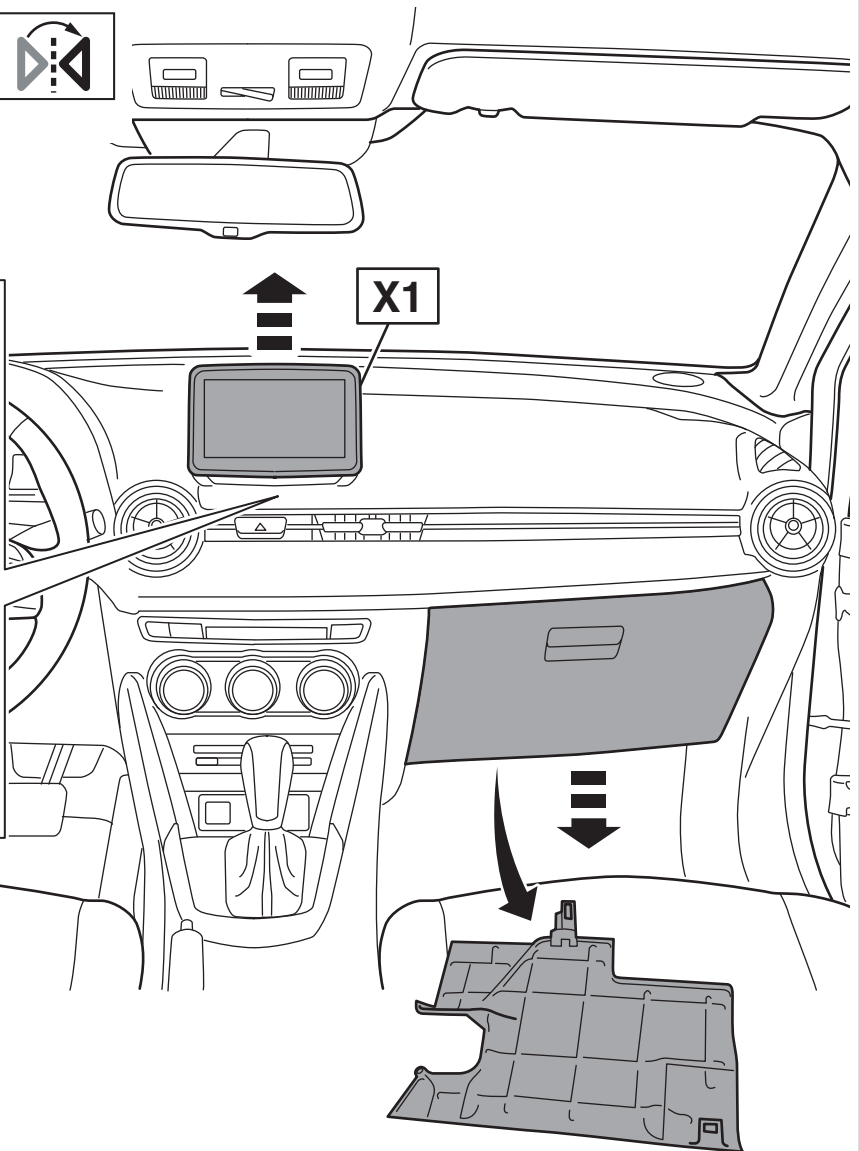
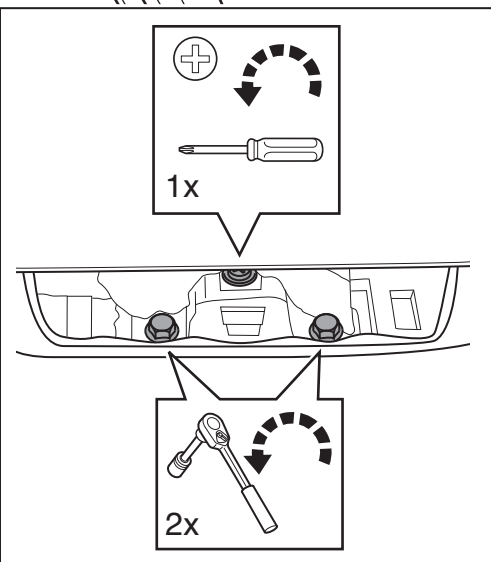

2

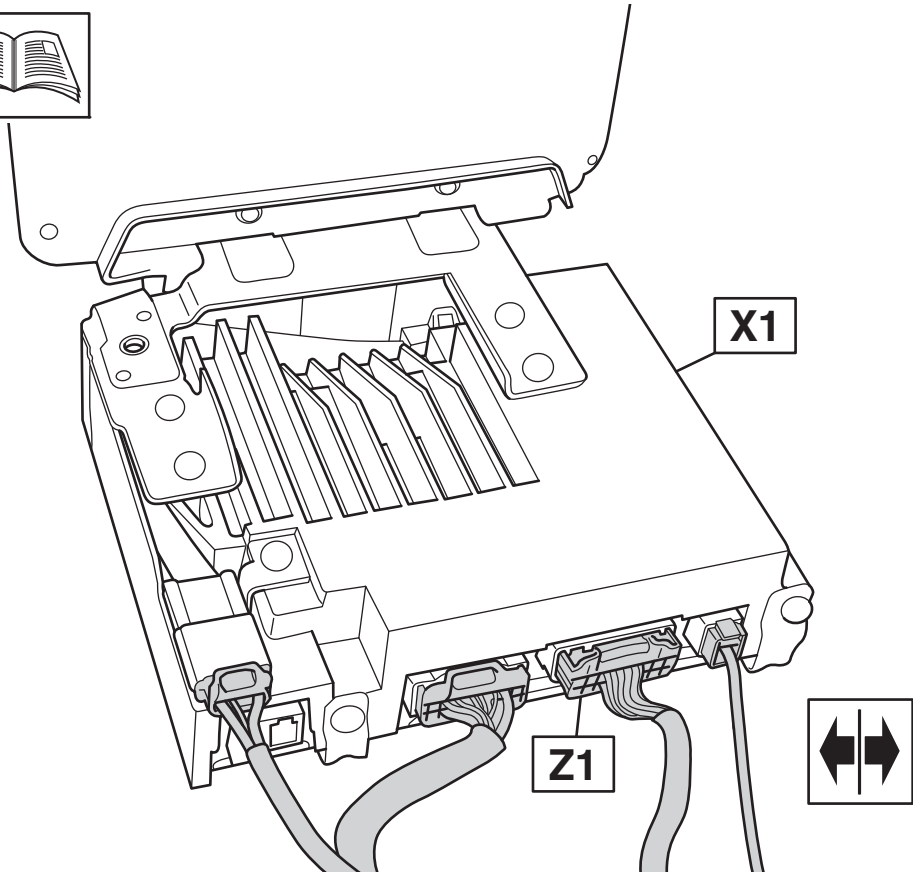

3

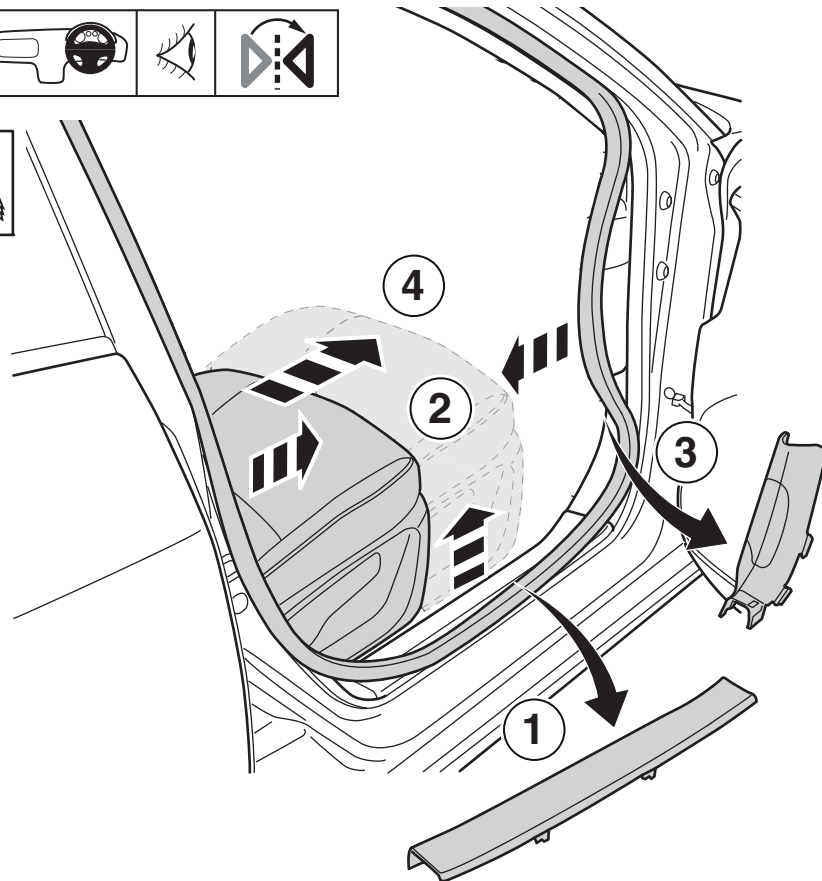
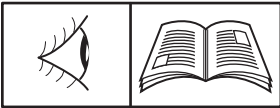

4

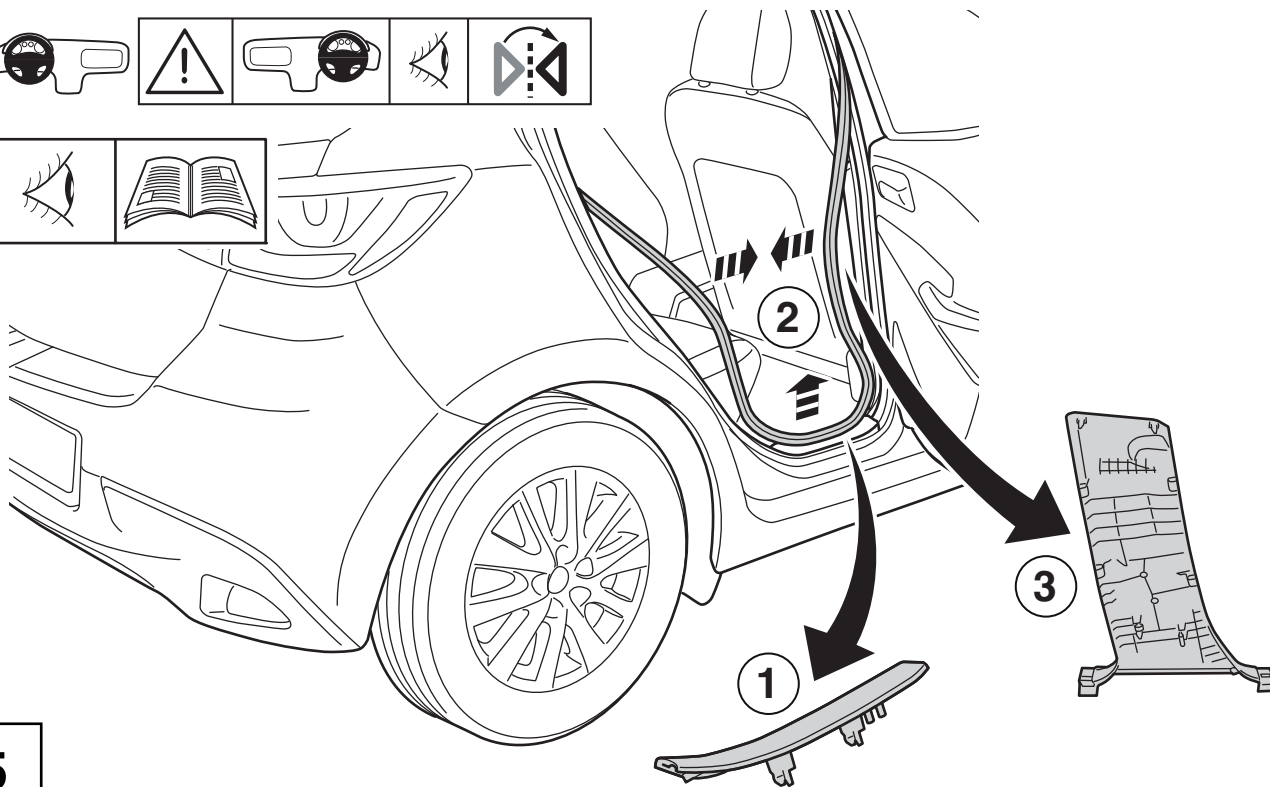

5

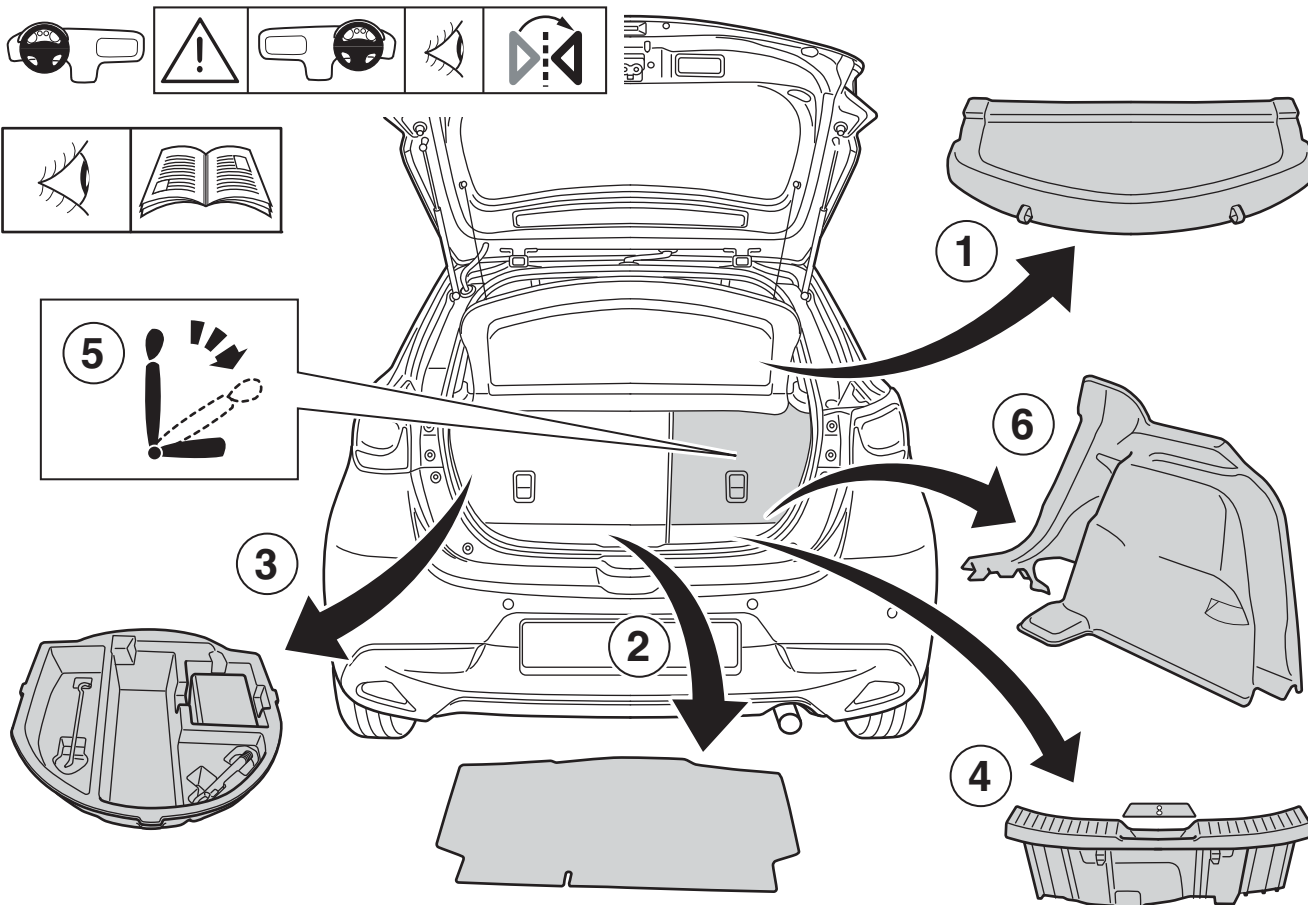
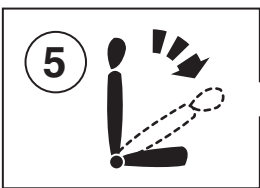

6

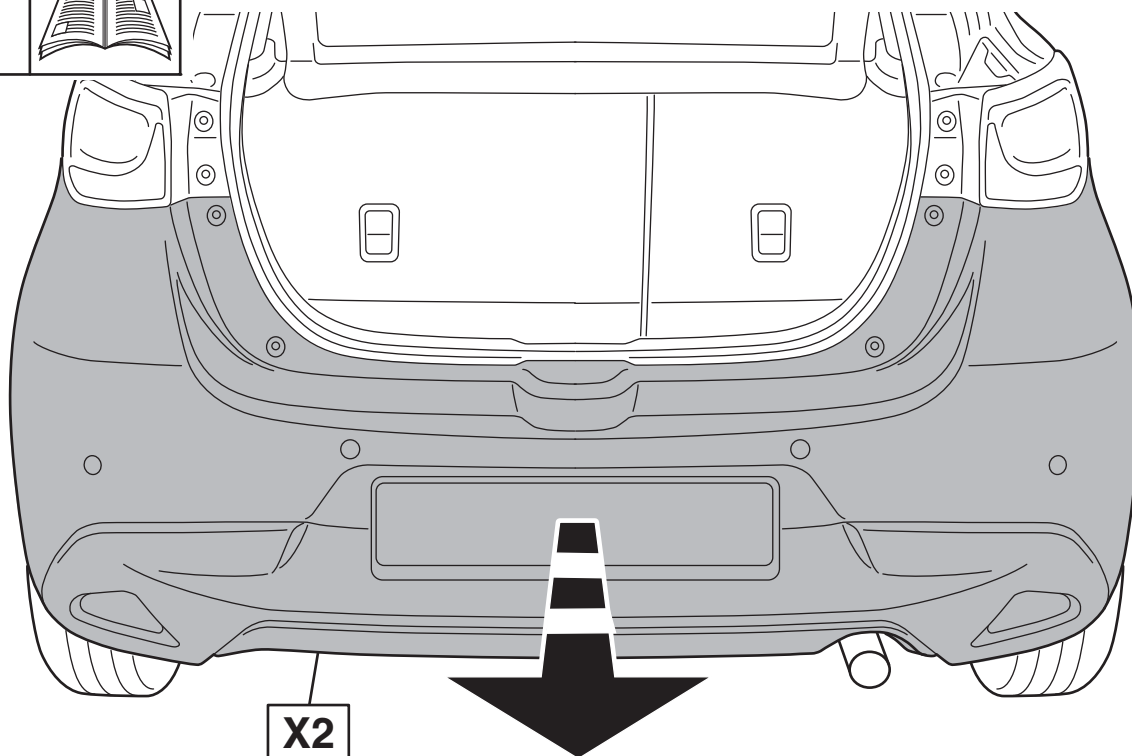

7

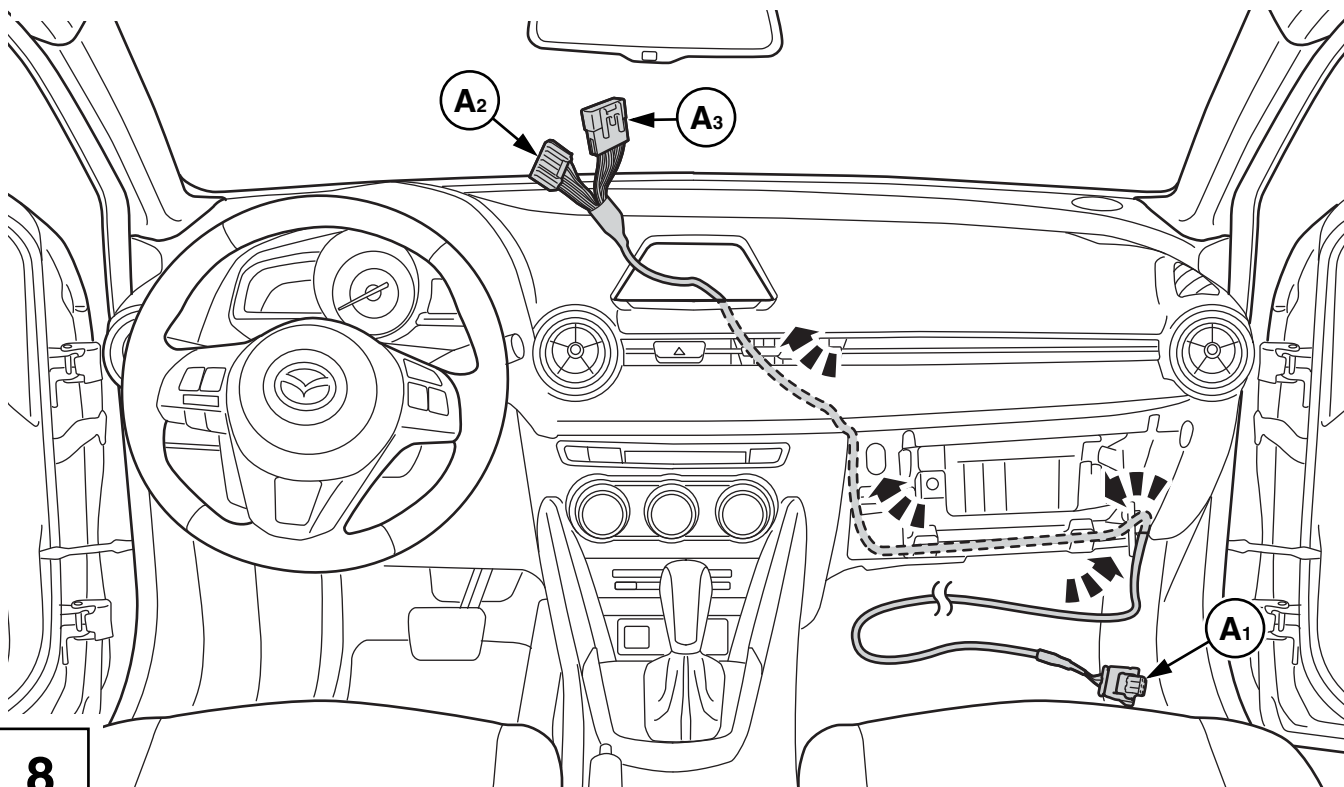

8

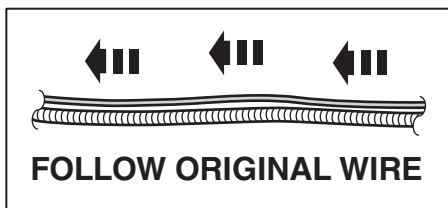
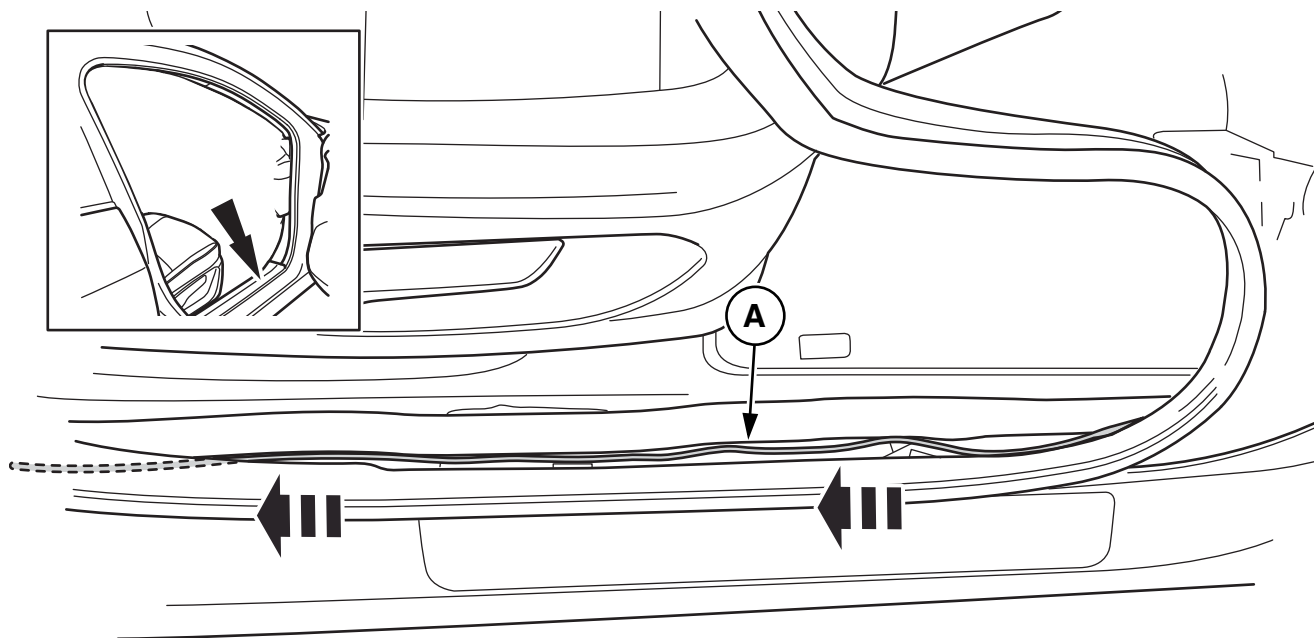

9

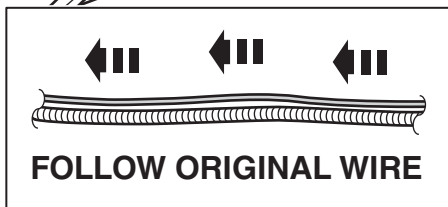
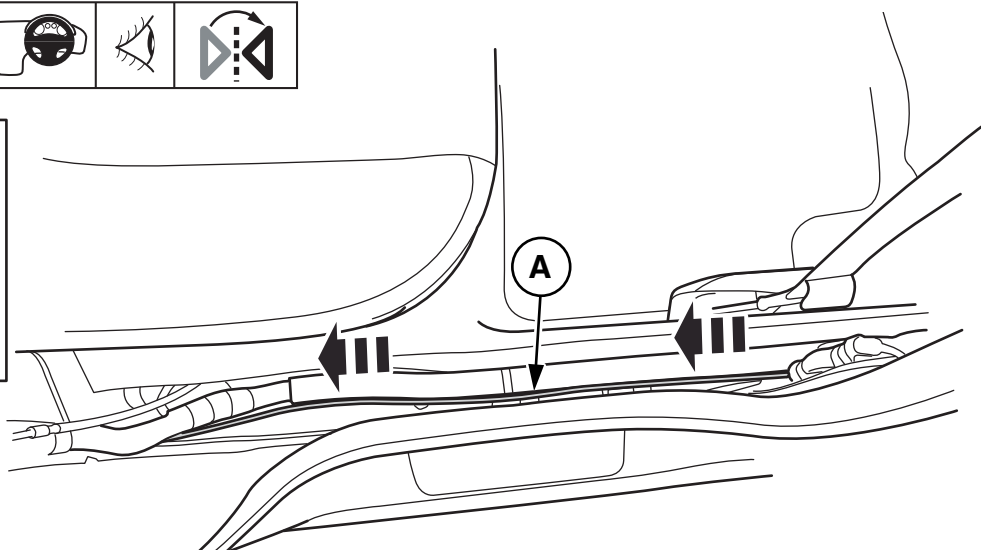
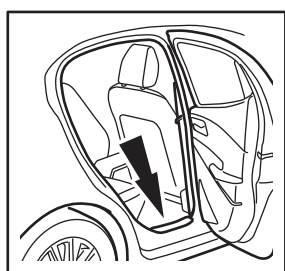
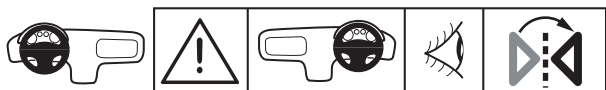

10

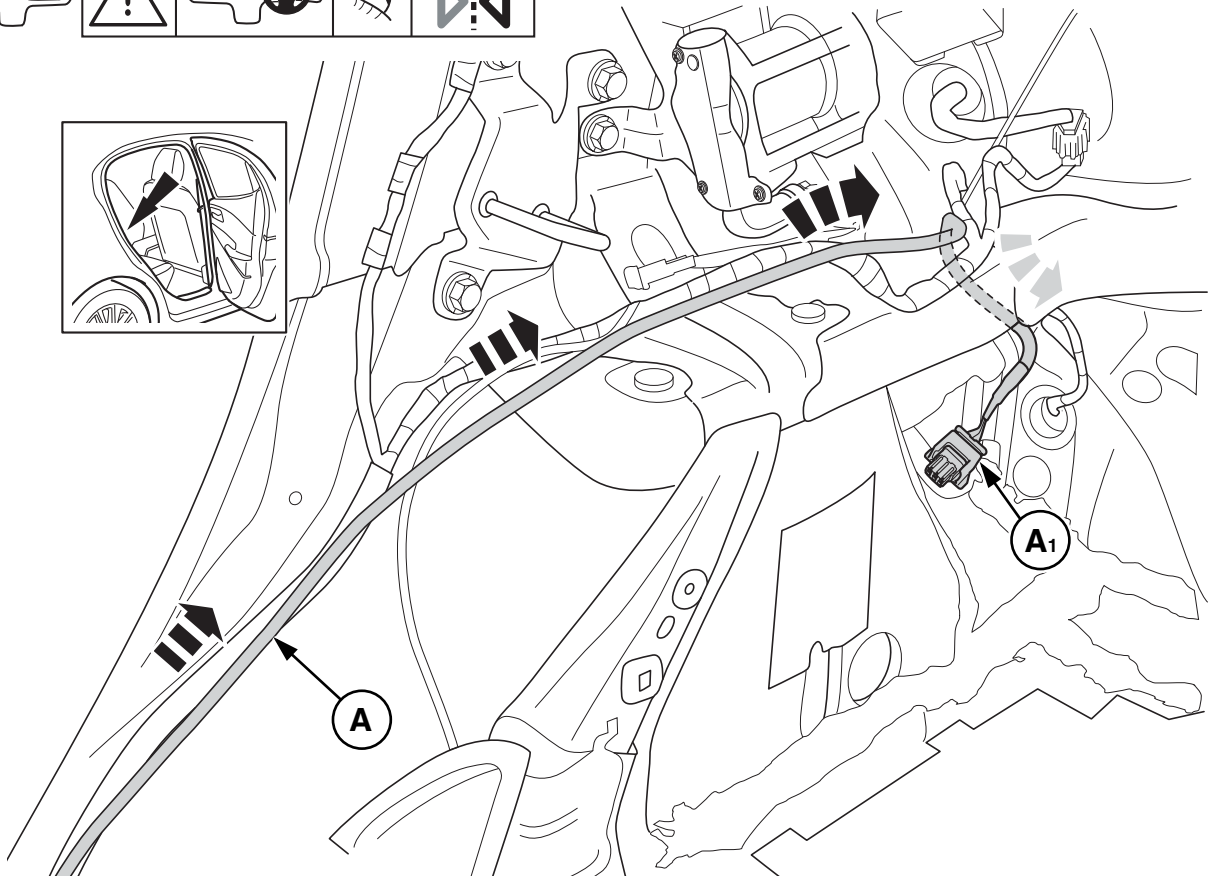
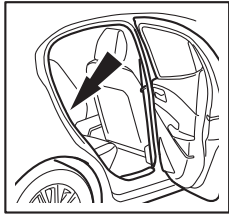
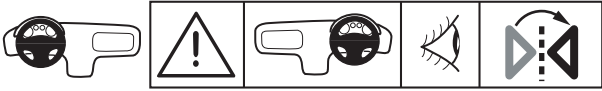

11

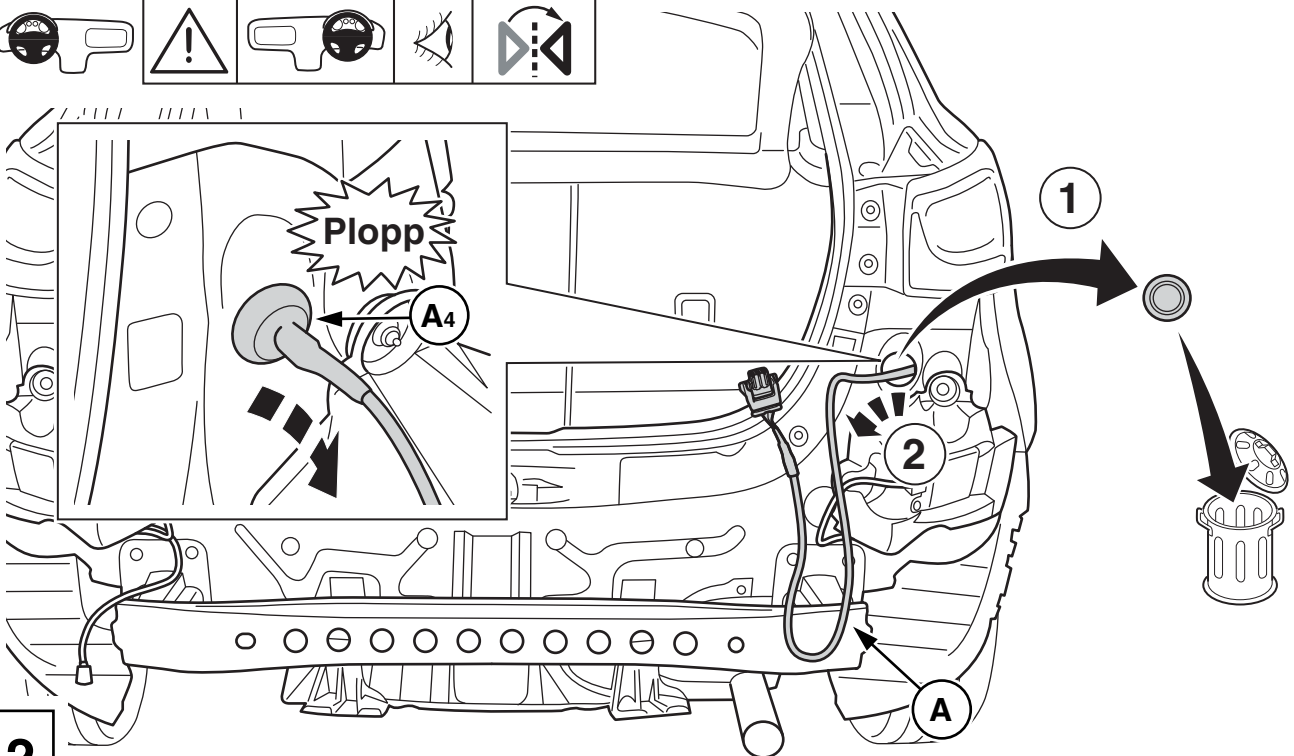
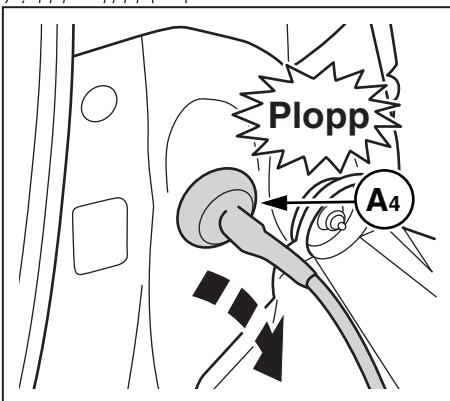

12

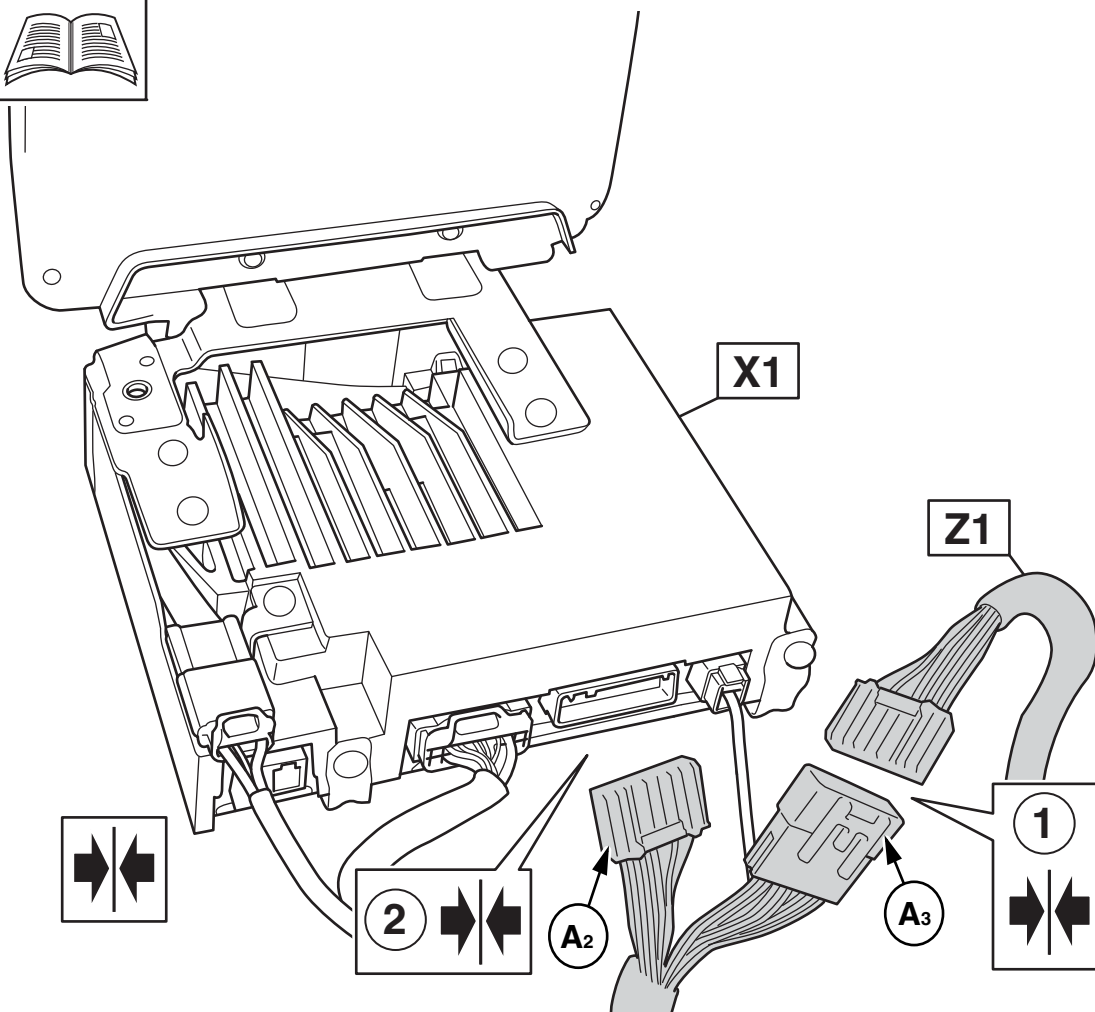

13

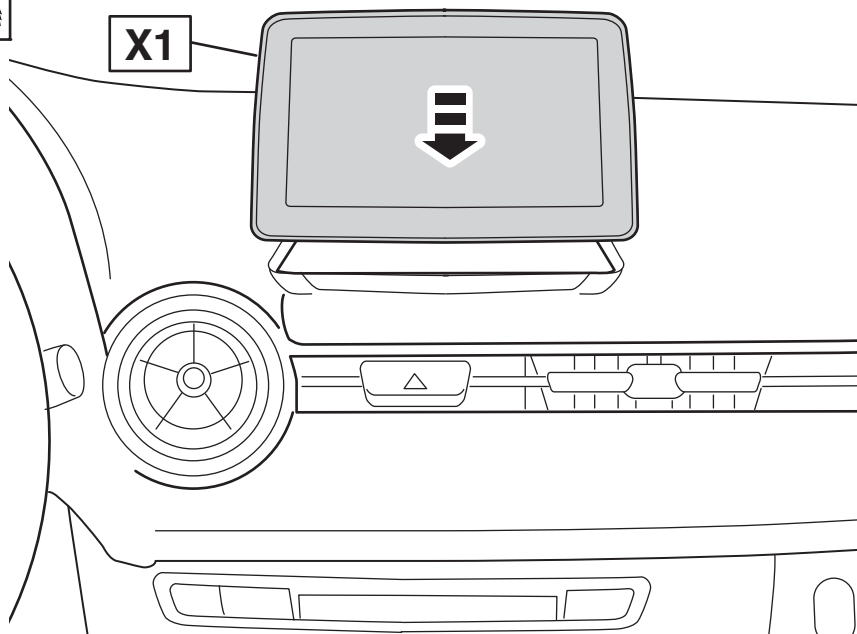

14

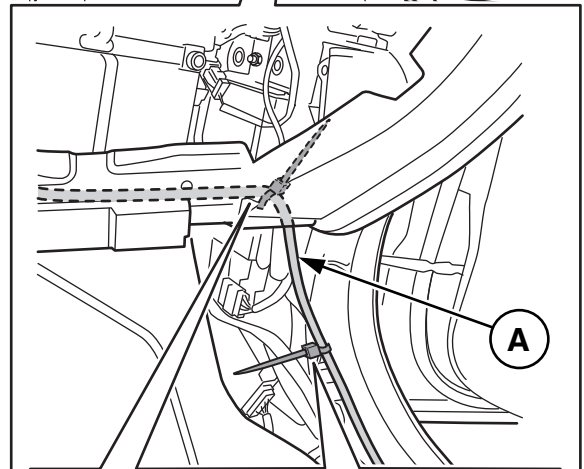
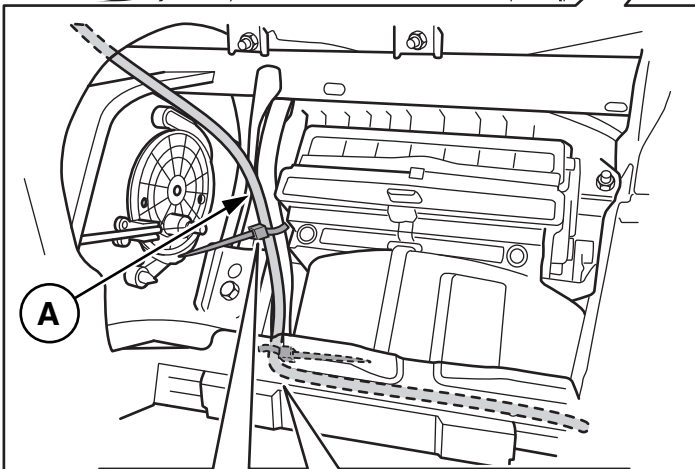
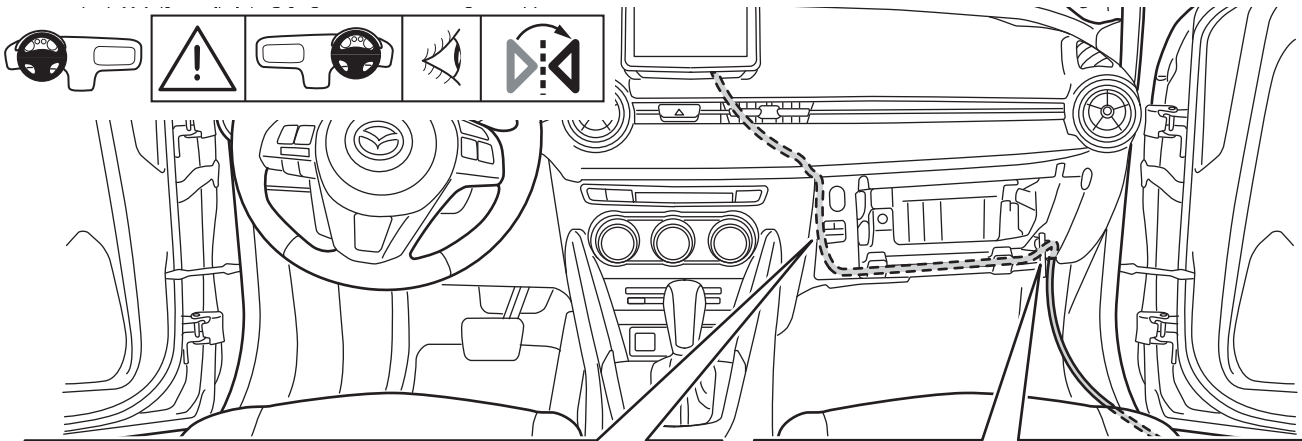

15

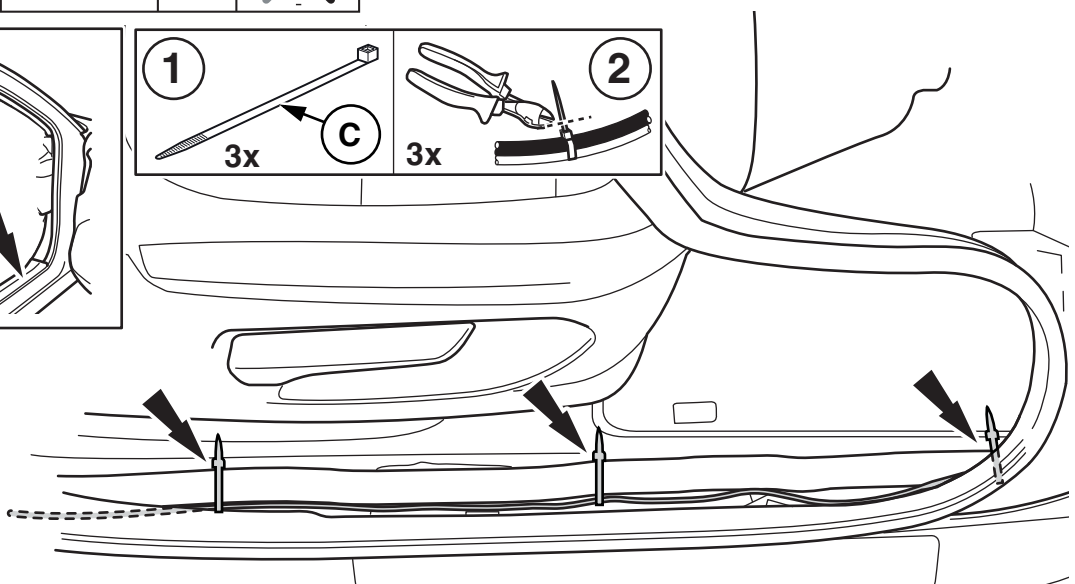
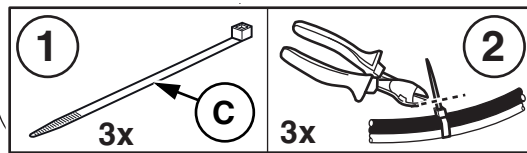
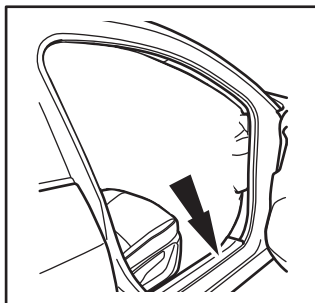

16

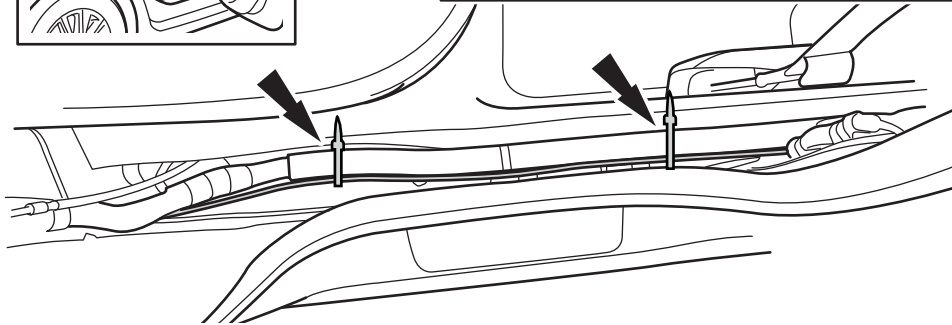
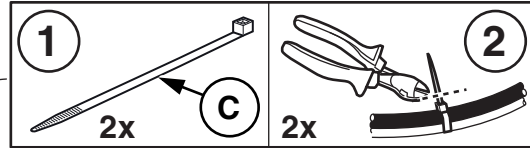
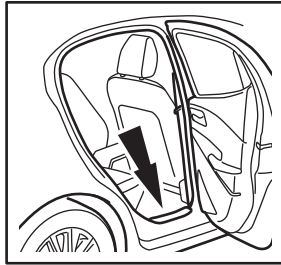

17

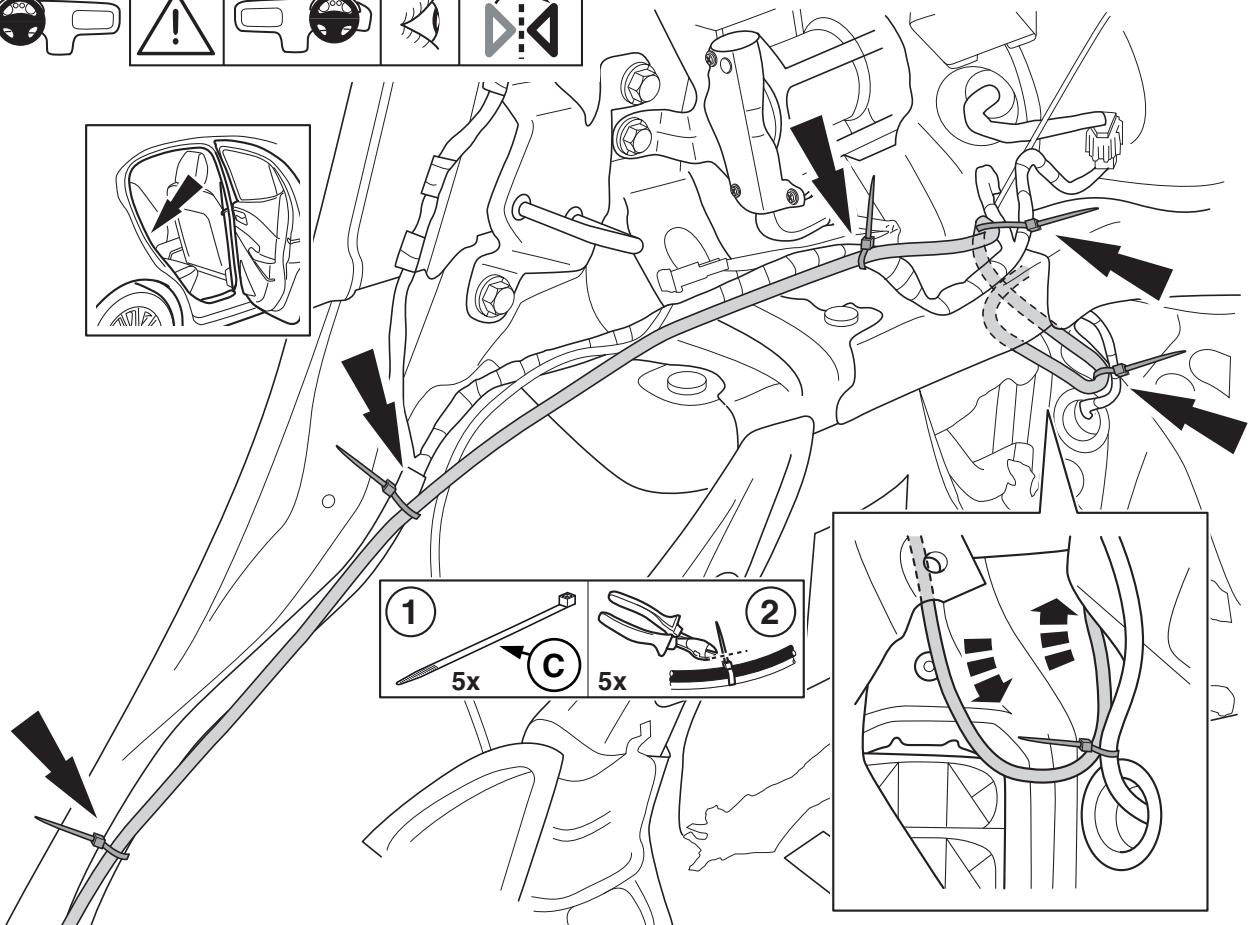
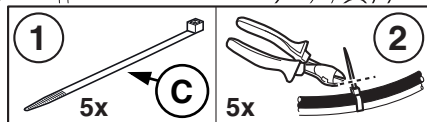
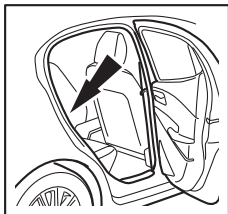
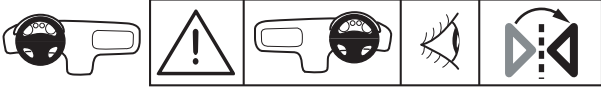

18

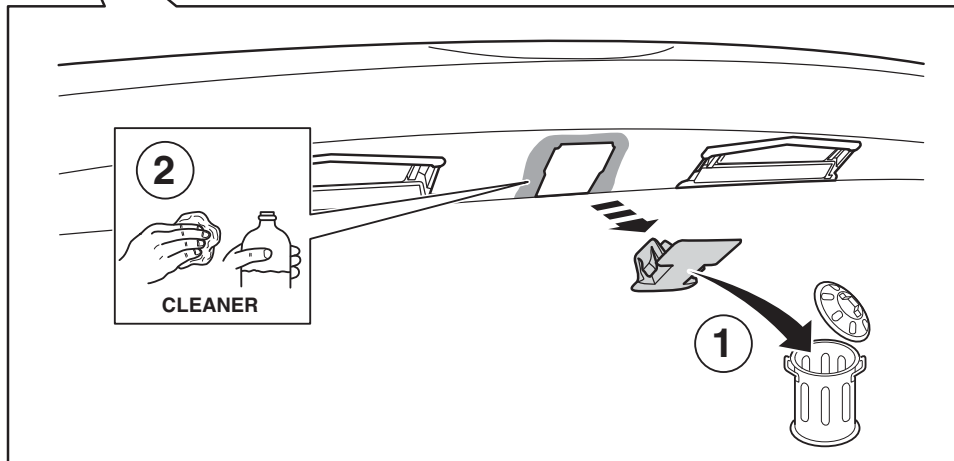
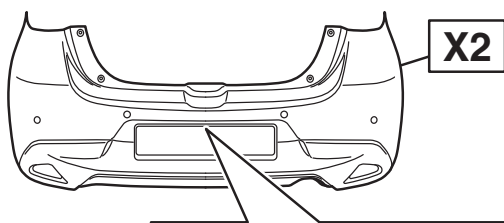
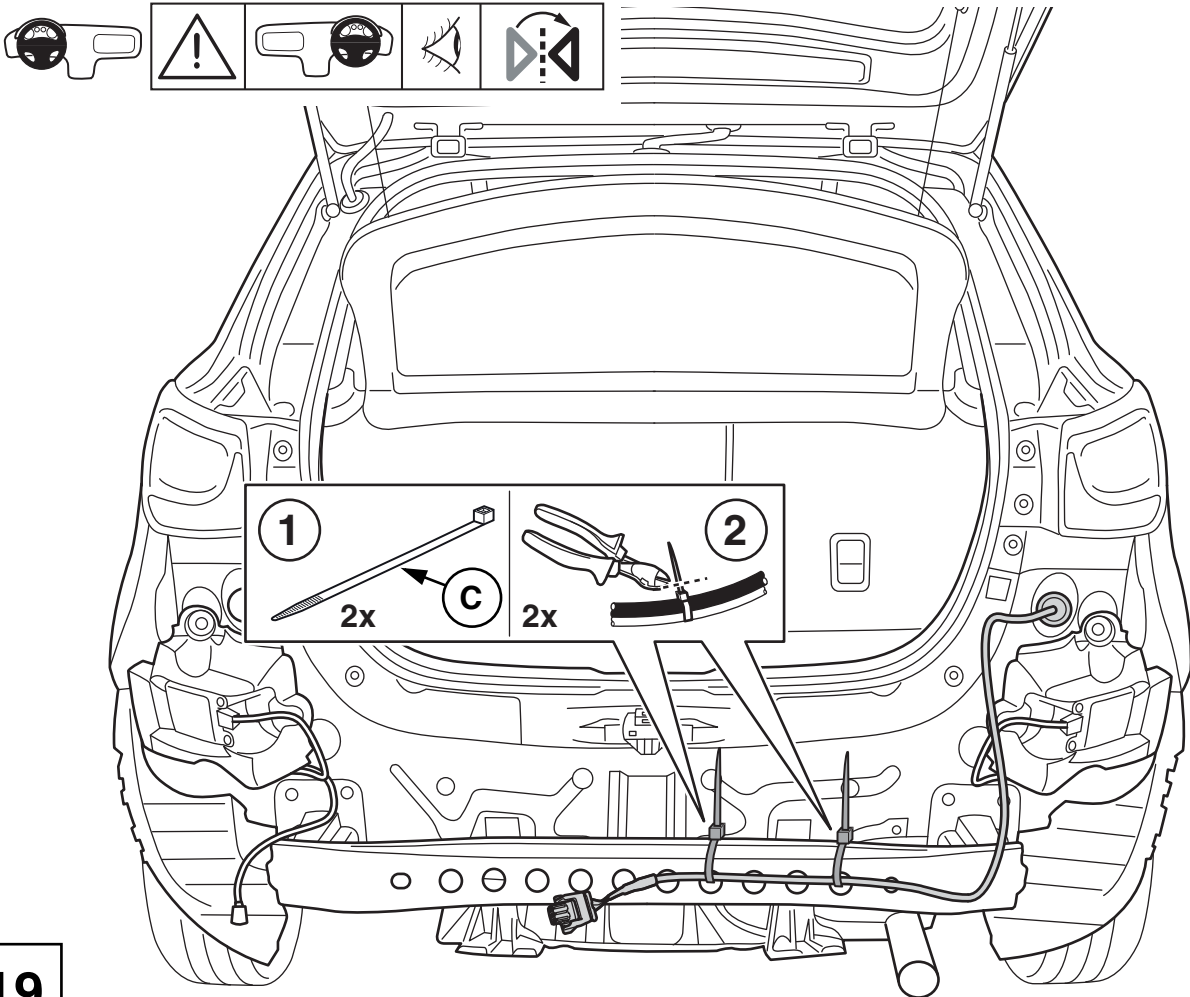

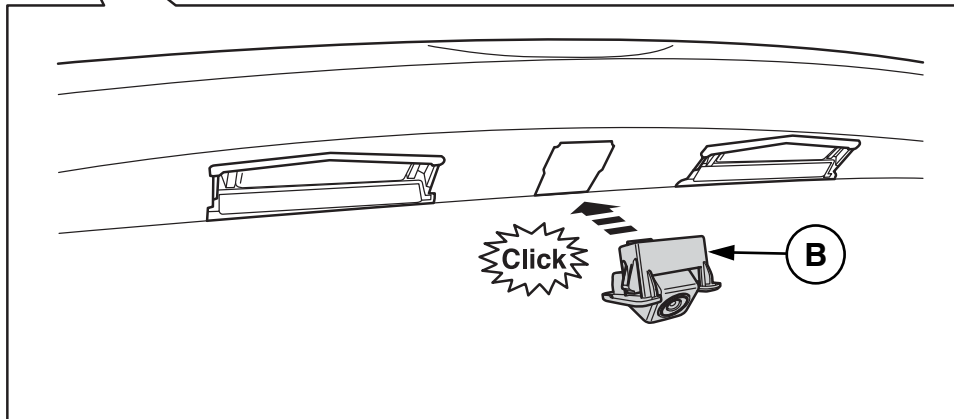
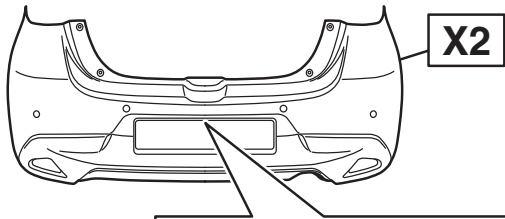

21

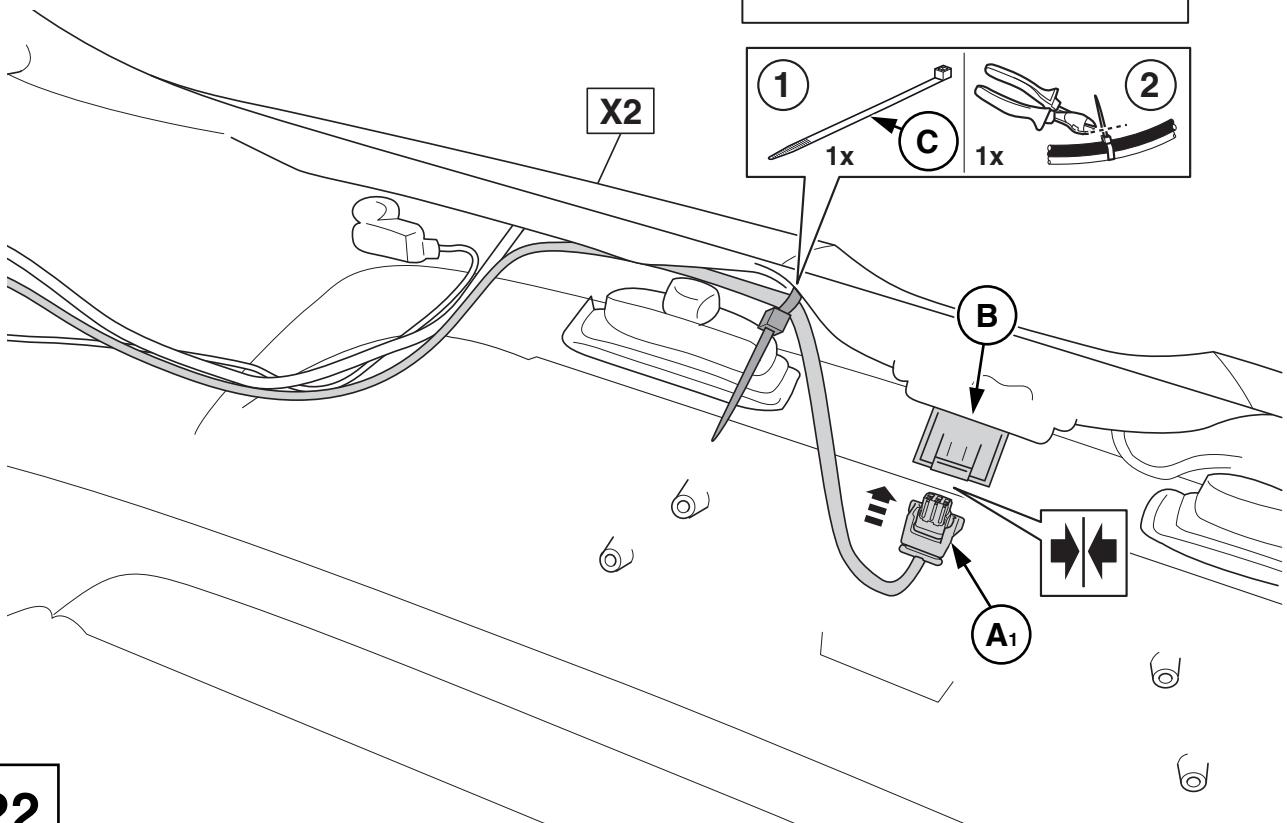
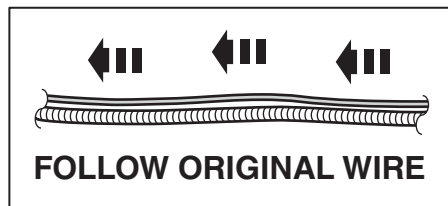

22

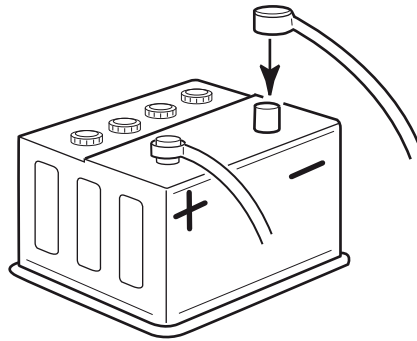

23

Subject to alteration without notice
 Technische Änderungen vorbehalten
 Reservadas modificaciones técnicas
 So Technische wijzigingen voorbehouden
 Med forbehold for tekniske İndringer
 Tekniske forendringer forbeholdes
 Med reservation för tekniska ändringar
 Tekniset muutokset pidätetään
 Technické zmeny vyhrazeny
 A változtatások technika jogát fenntartjuk
 Zmiany techniczne zastrzeżone
 Επιφύλασσόμεθα για αλλαγές
 Можно изменять без уведомления