

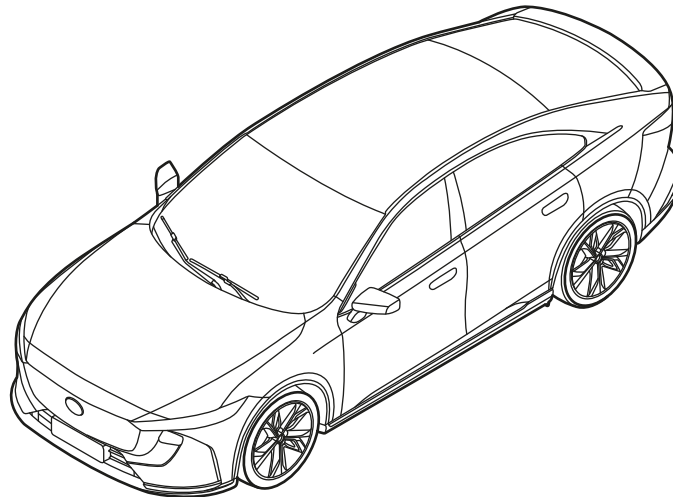

MAZDA

GB SCUFF PLATES (ILLUMINATED) Installation instruction	S INSTEGSLISTER (BELYSTA) Monteringsanvisning
D EINSTIEGSLEISTEN (BELEUCHTET) Einbauanleitung	SF KYNNYSLISTAT (VALAISTU) Asennusohje
E LISTONES DE UMBRAL (ILUMINADOS) Instrucciones de montaje	CZ NASTUPNI LISTY (OSVĚTLENÉ) Návod k montáži
F BASE DE PORTE (ÉCLAIRÉS) Notice de montage	H KÜSZÖBLÉCEK (MEGVILAGITVA) Beszerelési utasítása
I BATTICALCAGNO (ILLUMINATI) Istruzioni di montaggio	PL LISTWY PROGOWE (O WISTLONE) Instrukcja zabudowy
P EMBALADEIRAS (COM ILUMINAÇÃO) Instruções de montagem	GR ΠΡΟΣΤΑΤΕΥΤΙΚΑ ΕΠΙΒΙΒΑΣΗΣ (ΦΩΤΙΣΜΕΝΑ) Οδηγίες Τοποθέτησης
NL DREMPELFOLIES (VERLICHT) Inbouw-instructie	RU ВХОДНЫЕ ПЛАНКИ (ОСВЕЩАЕМЫЕ) Инструкция по установке
DK INDSTIGNINGSLISTER (BELYST) Monteringsvejledning	SVK SKUFNE PLOŠČE (OSVETLJENE) Návod na inštaláciu
N STIGTRINN (MED LYS) Monteringsveiledning	



MAZDA 6e

GN

Part No: **GJBK-V1-370A**

Date: 28-10-2025

© Copyrights MAZDA

Sheet 1 of 12

Expert Fitment Required
Montage durch Fachwerkstatt erforderlich
Montaje sólo por el concesionario
Montage par spécialiste nécessaire
E' necessario in officina specializzata
Especialista em montagem requerido
Montage door vakman nodig
Montage ved professionelt værksted påkrævet
Nødvendig med montering fra fagvevkersted
Verkstadsmontage erfordras
Asennus tarpeen merkkikorjaamossa
Montáž ve specializované dílně nutná
A szereléshez szakmúhely kell
Konieczny montaż przez warsztat specjalistyczny
Να τοποθεί από συνεργείο
Необходима подгонка специалистом
Vyžaduje sa odborné vybavenie

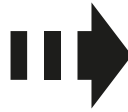

- (GB)** Position arrow
- (D)** Positionspfeil
- (E)** Flecha de posición
- (F)** Flèche de position
- (I)** Freccia di posizione
- (P)** Flexa de posição
- (NL)** Lokatie/Positie pijl
- (DK)** Lokaliseringspil
- (N)** Posisjonspil
- (S)** Positionpil
- (SF)** Paikannusnuoli
- (CZ)** Šipka na pozici
- (H)** Helyzetjelző nyíl
- (PL)** Strzałka położenia
- (GR)** Βέλος θέσης
- (RUS)** Стрелка расположения
- (SVK)** Šipka polohy

- (GB)** Movement arrow
- (D)** Bewegungspfeil
- (E)** Flecha de movimiento
- (F)** Flèche de mouvement
- (I)** Freccia di movimento
- (P)** Flexa de movimento
- (NL)** Richtingspijl
- (DK)** Bevægelsespil
- (N)** Bevegelsespil
- (S)** Rörelsepil
- (SF)** Liikesuuntanuoli
- (CZ)** Šipka pohybu
- (H)** Mozgásirányjelző nyíl
- (PL)** Strzałka kierunku ruchu
- (GR)** Βέλος κίνησης
- (RUS)** Стрелка движения
- (SVK)** Šipka pohybu

- (GB)** Same procedure for the left and right side
- (D)** Gleicher einbau für linke und rechte Seite
- (E)** Mismo procedimiento para lado izquierdo y derecho
- (F)** Procédure identique pour les côtés gauche et droit
- (I)** Stessa procedura valida per il lato destro e sinistro
- (P)** Mesmo procedimento para o lado esquerdo e direito
- (NL)** Dezelfde procedure voor de linker en rechter zijde
- (DK)** Samme fremgangsmåde for venstre og højre side
- (N)** Samme prosedyre for venstre og høyre side
- (S)** Samma åtgärd för vänster och höger sida
- (SF)** Samat toimenpiteet vasemmalla ja oikealle puolelle
- (CZ)** Postup je stejný pro levou i pravou stranu
- (H)** Az eljárás azonos a bal és a jobboldalon
- (PL)** Te same czynności należy wykonać po lewej i prawej stronie
- (GR)** Ίδια διαδικασία για την αριστερή και τη δεξιά πλευρά
- (RUS)** Одинаковая последовательность действий как для левой, так и для правой стороны
- (SVK)** Rovnaký postup pre ľavú a pravú stranu



- (GB)** Tape up
- (D)** Mit Klebeband befestigen
- (E)** Fijar con cinta adhesiva
- (F)** Fixer avec ruban adhésif
- (I)** Fissare con nastro adesivo
- (P)** Sujeitar com fita adesiva
- (NL)** Vastzetten met tape
- (DK)** Fastgøres med tape
- (N)** Fest fast med klebeband
- (S)** Fästet med tejp
- (SF)** Kiinnitys teipillä
- (CZ)** Upevnit lepicí páskou
- (H)** Rögzítse ragasztószalaggal
- (PL)** Umocować taśmą samoprzylepną
- (GR)** Στερέωση με κολλητική ταινία
- (RUS)** Закрепите клейкой лентой
- (SVK)** Páskou nahor

- (GB)** Warning
- (D)** Achtung
- (E)** Atención
- (F)** Attention
- (I)** Attenzione
- (P)** Atenção
- (NL)** Let op
- (DK)** Bemærk
- (N)** Pass på
- (S)** Varning
- (SF)** Huomio
- (CZ)** Pozor
- (H)** Figyelem
- (PL)** Uwaga
- (GR)** Προσοχή
- (RUS)** Осторожно
- (SVK)** Výstraha

- (GB)** Throw away
- (D)** Entsorgen
- (E)** Tratamiento de residuos
- (F)** Rebuter
- (I)** Smaltire
- (P)** Eliminar
- (NL)** Weggooien
- (DK)** Affald
- (N)** Avskaffe
- (S)** Ta hand om avfallet
- (SF)** Hävittää
- (CZ)** Vyhodit
- (H)** Távolítsa el
- (PL)** Usunąć jako odpad
- (GR)** Απόσυρση
- (RUS)** Выбросите
- (SVK)** Zahodit'

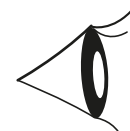

- (GB)** Wipe clean
- (D)** Reinigen
- (E)** Limpiar
- (F)** Nettoyer
- (I)** Ripulire
- (P)** Limpiar
- (NL)** Zuiver maken
- (DK)** Aftørring
- (N)** Rengjøring
- (S)** Rengör
- (SF)** Puhdista
- (CZ)** Očistit
- (H)** Tisztítsa meg
- (PL)** Oczyszczyć
- (GR)** Καθάρισμα
- (RUS)** Протрите дочиста
- (SVK)** Čistiť utieraním

- (GB)** See installation instructions
- (D)** Siehe Installationsanleitung
- (E)** Consulte las Instrucciones de instalación
- (F)** Voir les instructions d'installation
- (I)** Vedere le istruzioni di installazione
- (P)** Veja as instruções de instalação
- (NL)** Zie installatie-instructies
- (DK)** Se monteringsvejledning
- (N)** Se installeringsveiledningen
- (S)** Se installationssanvisningarna
- (SF)** Katso asennusohjeet
- (CZ)** Viz instalační pokyny
- (H)** Lásd a telepítési utasításokat
- (PL)** Patrz instrukcja instalacji
- (GR)** Βλέπε οδηγίες εγκατάστασης
- (RUS)** См. инструкции по установке
- (SVK)** Pozrite si návod na inštaláciu

- (GB)** Look/See
- (D)** Siehe
- (E)** Ver
- (F)** Voir
- (I)** Vedere
- (P)** Cf.
- (NL)** Kijken naar
- (DK)** Se
- (N)** Se
- (S)** Se
- (SF)** Katso
- (CZ)** Viz
- (H)** Lásd
- (PL)** Patrz
- (GR)** βλέπε
- (RUS)** См.
- (SVK)** Pozriet'/Zobrazit'

- (GB)** Repeat
- (D)** Wiederholen
- (E)** Repita
- (F)** Répéter
- (I)** Ripetizione
- (P)** Repetir
- (NL)** Herhaal
- (DK)** Gentage
- (N)** Gjenta
- (S)** Upprepa
- (SF)** Toista
- (CZ)** Opakování
- (H)** Ismétlés
- (PL)** Powtórzenie
- (GR)** Επανάληψη
- (RUS)** Повторите
- (SVK)** Opakujte



(GB) Magnetic
(D) Magnetisch
(E) Magnético
(F) Magnétique
(I) Magnetico
(P) Magnetyczny
(NL) Magnetisch
(DK) Magnetisk
(N) Magnetisk
(S) Magnetisk
(SF) Magneettinen
(CZ) Magnetický
(H) Mágneses
(PL) Magnetyczny
(GR) Μαγνητικός
(RUS) Магнитный
(SVK) Magnetické

(GB) Batterie Leakage Possible
(D) Batterie Ausfluss möglich
(E) Posible fuga de la batería
(F) Fuite de batterie possible
(I) Possibile perdita della batteria
(P) Possível vazamento de bateria
(NL) Batterijlekkage mogelijk
(DK) Batterilækage mulig
(N) Mulig batterilekkasje
(S) Batteriläckage möjligt
(SF) Akun vuoto mahdollinen
(CZ) Možný únik baterie
(H) Elemszivárgás lehetséges
(PL) Możliwe wycieki baterii
(GR) Πιθανή διαρροή μπαταρίας
(RUS) Возможная утечка батареи
(SVK) Možný únik batérie

(GB) Risk of Injury
(D) Verletzungsgefahr
(E) Riesgo de lesión
(F) Risque de blessure
(I) Rischio di lesioni
(P) Risco de lesão
(NL) Risico op letsel
(DK) Risiko for skade
(N) Fare for skade
(S) Risk för skada
(SF) Loukkaantumisvaara
(CZ) Nebezpečí zranění
(H) Sérülésveszély
(PL) Ryzyko obrażeń
(GR) Κίνδυνος τραυματισμού
(RUS) Риск травмы
(SVK) Riziko zranenia

1 **LH RH**

Vehicle front

86°F 30°C
↓ ↓
61°F 16°C
↑ ↑

1

CLEANER

2

2-3 min

2 **E/F**

R

2 RH

Vehicle front →

1 RH

Vehicle front →

L

1 LH

← Vehicle front

2 LH

← Vehicle front

LH RH

55 cm

10 cm

2 RH

Vehicle front →

1 RH

Vehicle front →

→ Vehicle front

3 **LH RH**

55 cm

1

2

Vehicle front →

→ Vehicle front

4 **LH RH**

10 cm

2

Vehicle front →

1

→ Vehicle front

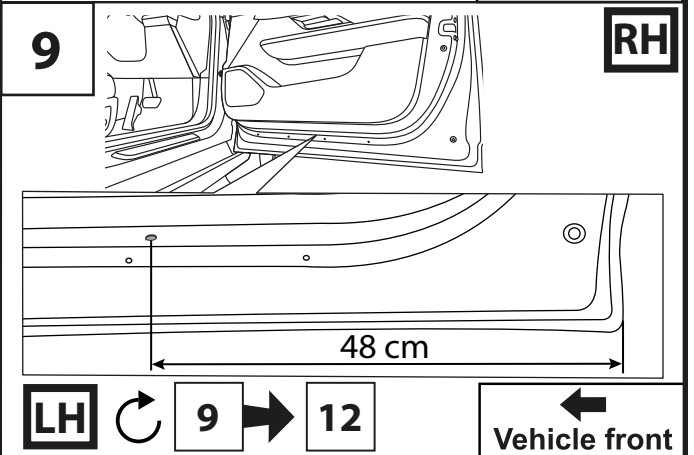
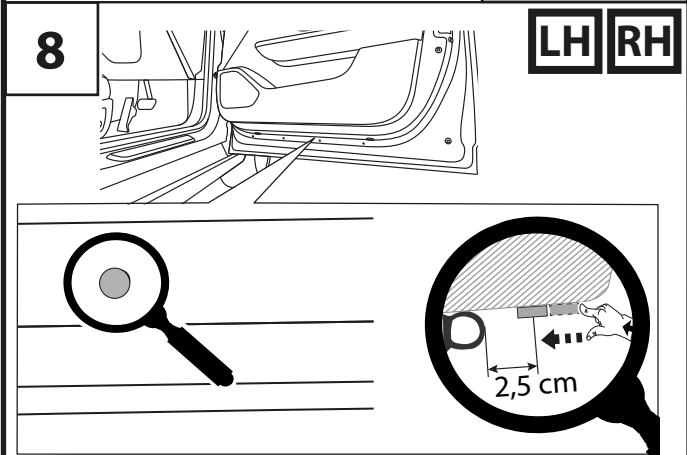
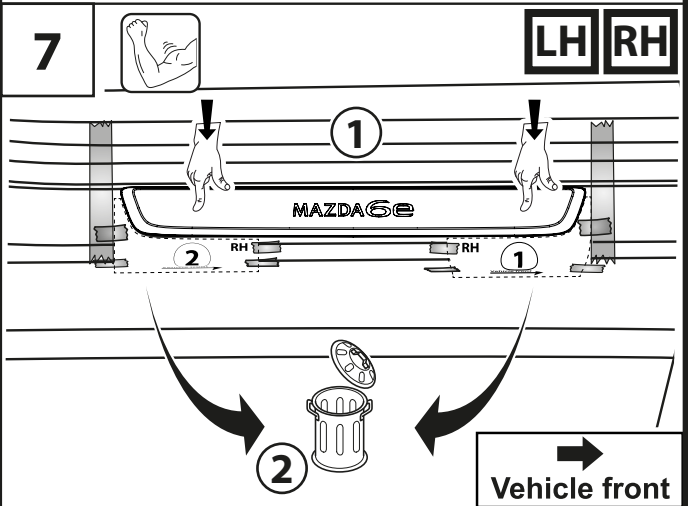
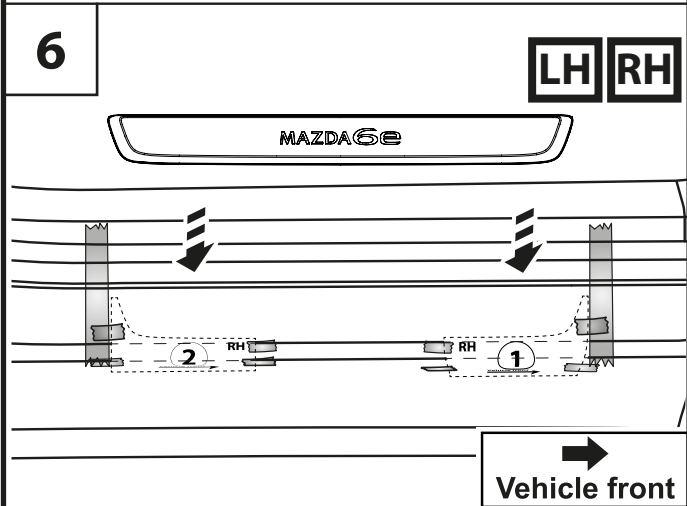
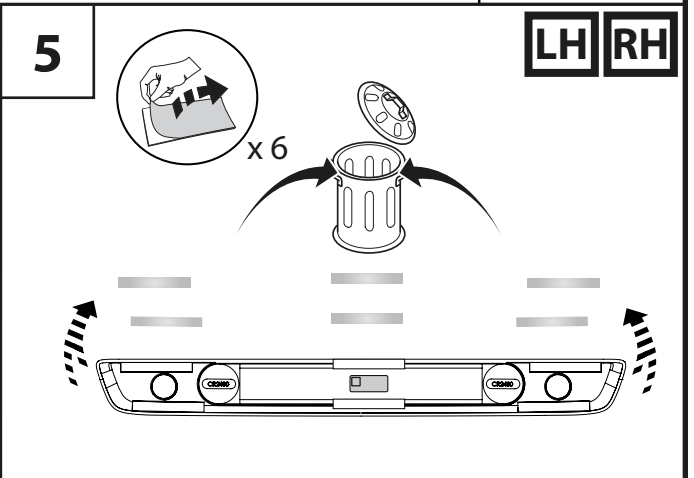
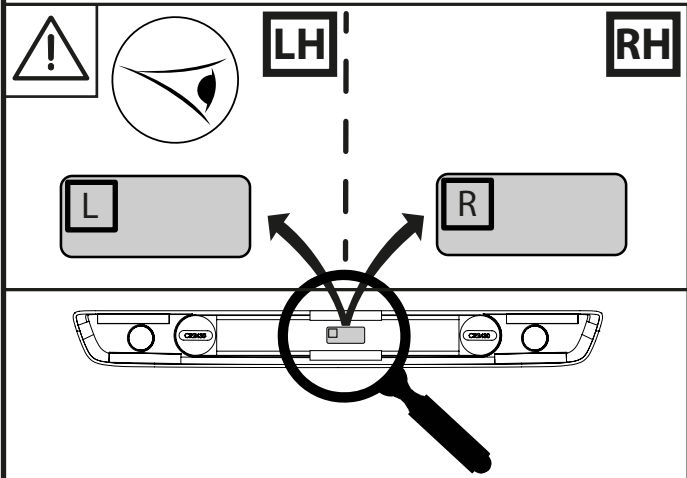
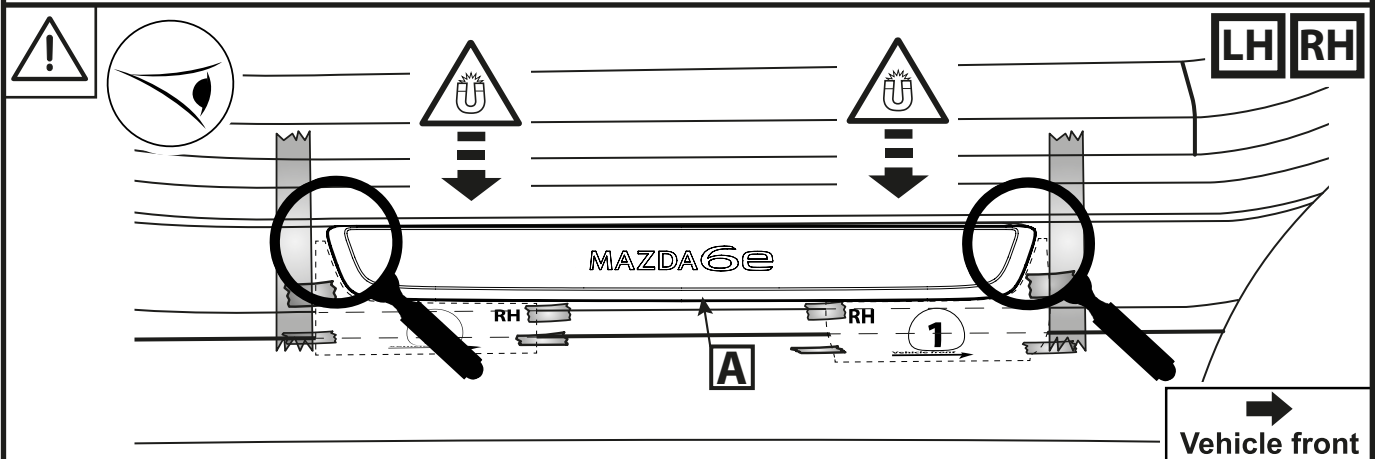

10

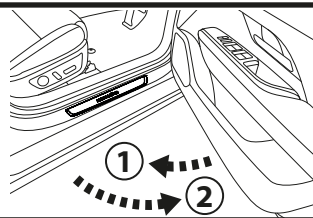

LH RH

Vehicle front

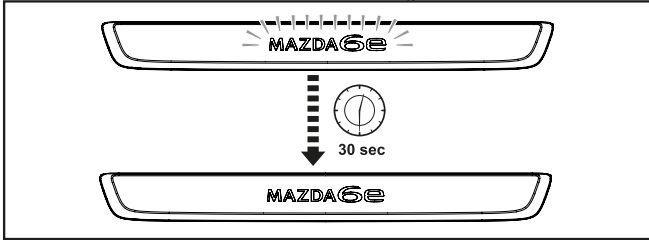

11

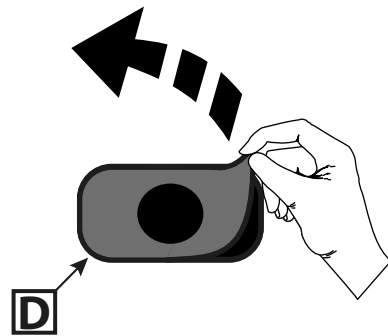

12

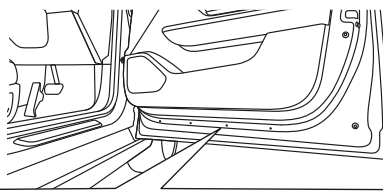

RH

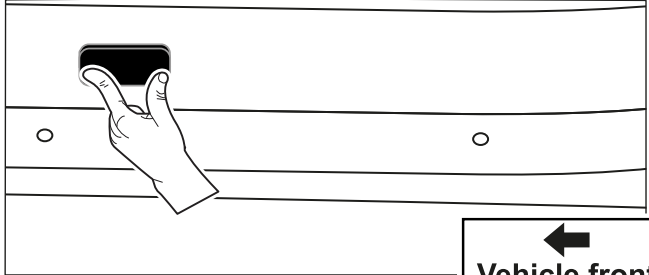

Vehicle front

13

LH RH

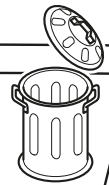
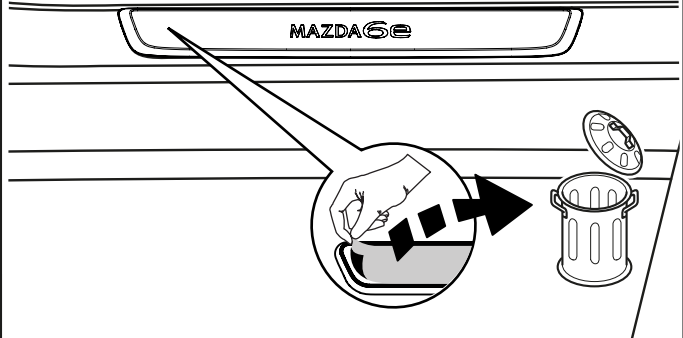

14

Vehicle front

LH RH

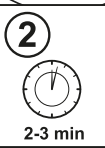
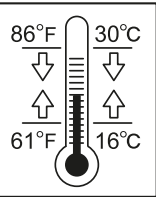
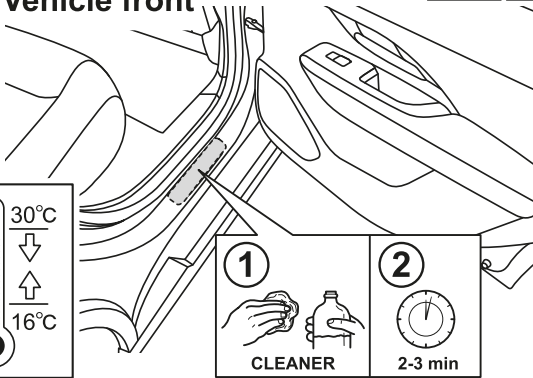

15



E/F

R

RH

3

Vehicle front



L

LH

3

Vehicle front

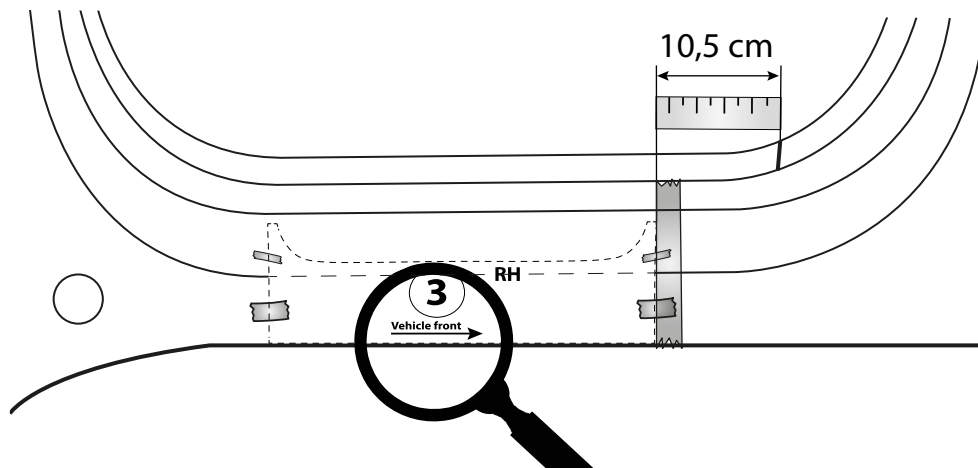

LH RH

Vehicle front

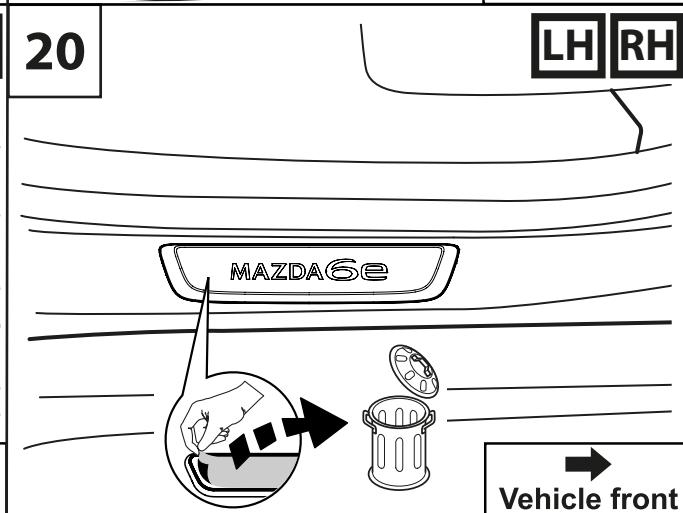
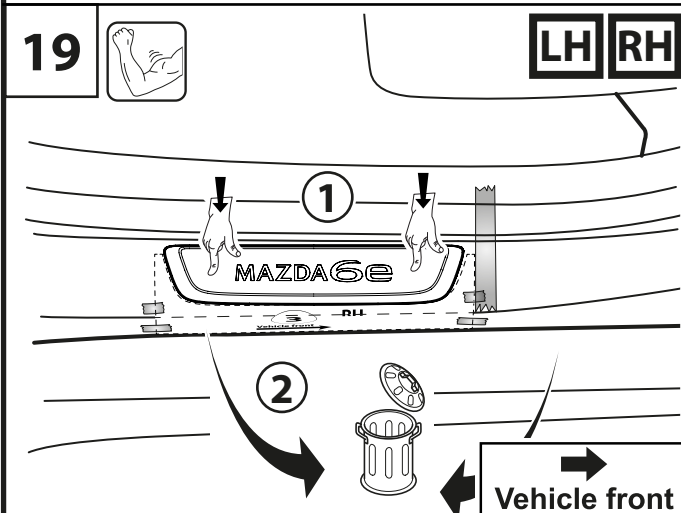
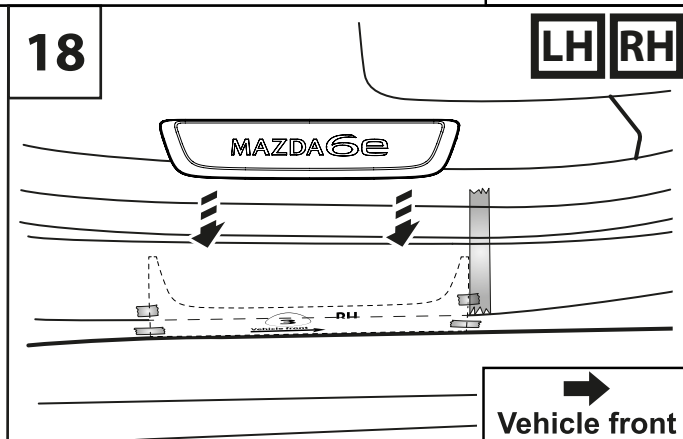
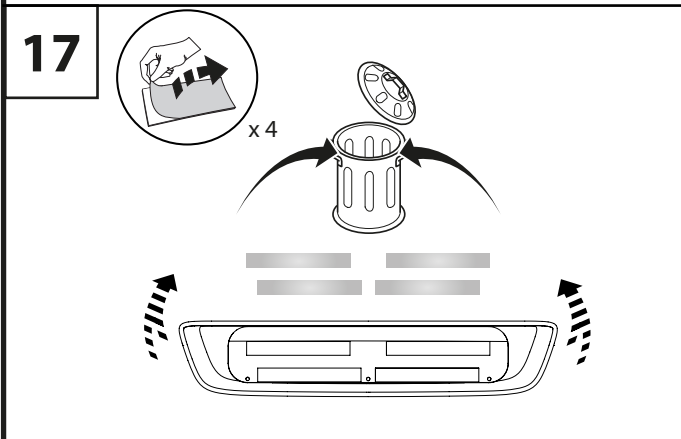
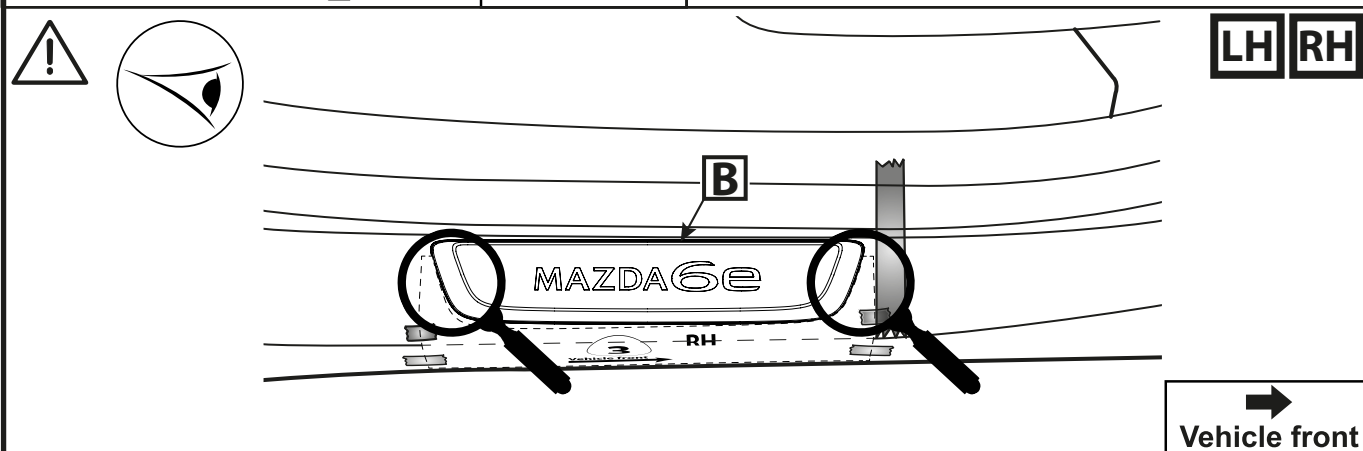
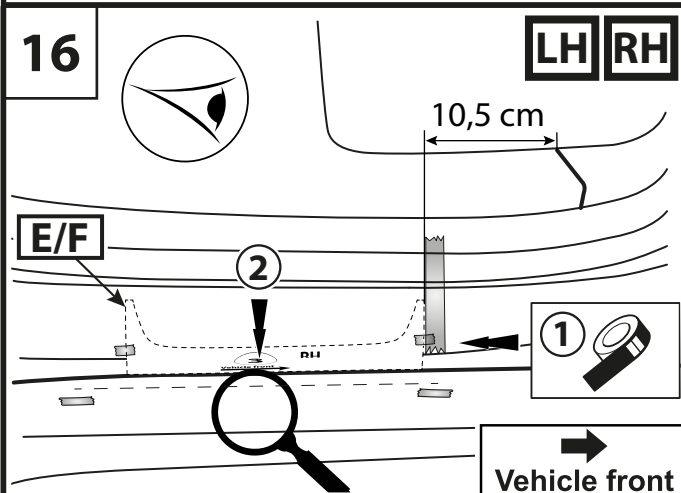

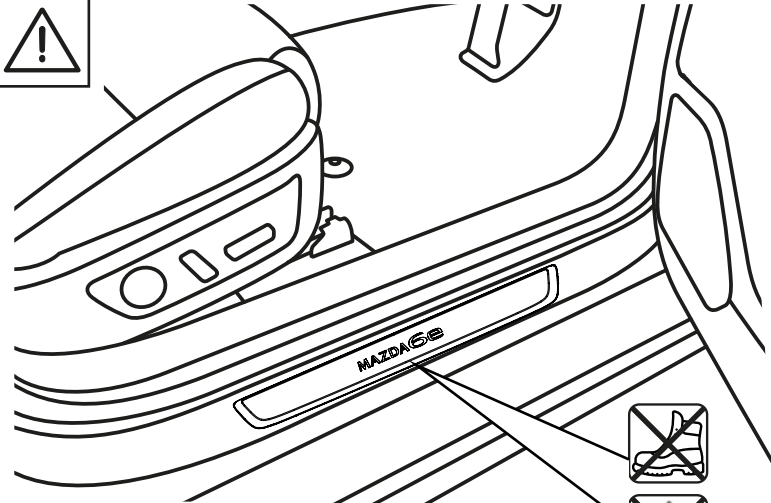

Do not scratch!

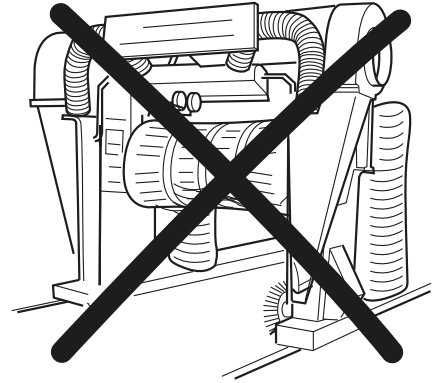
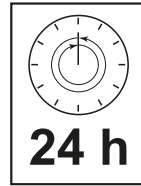

Template

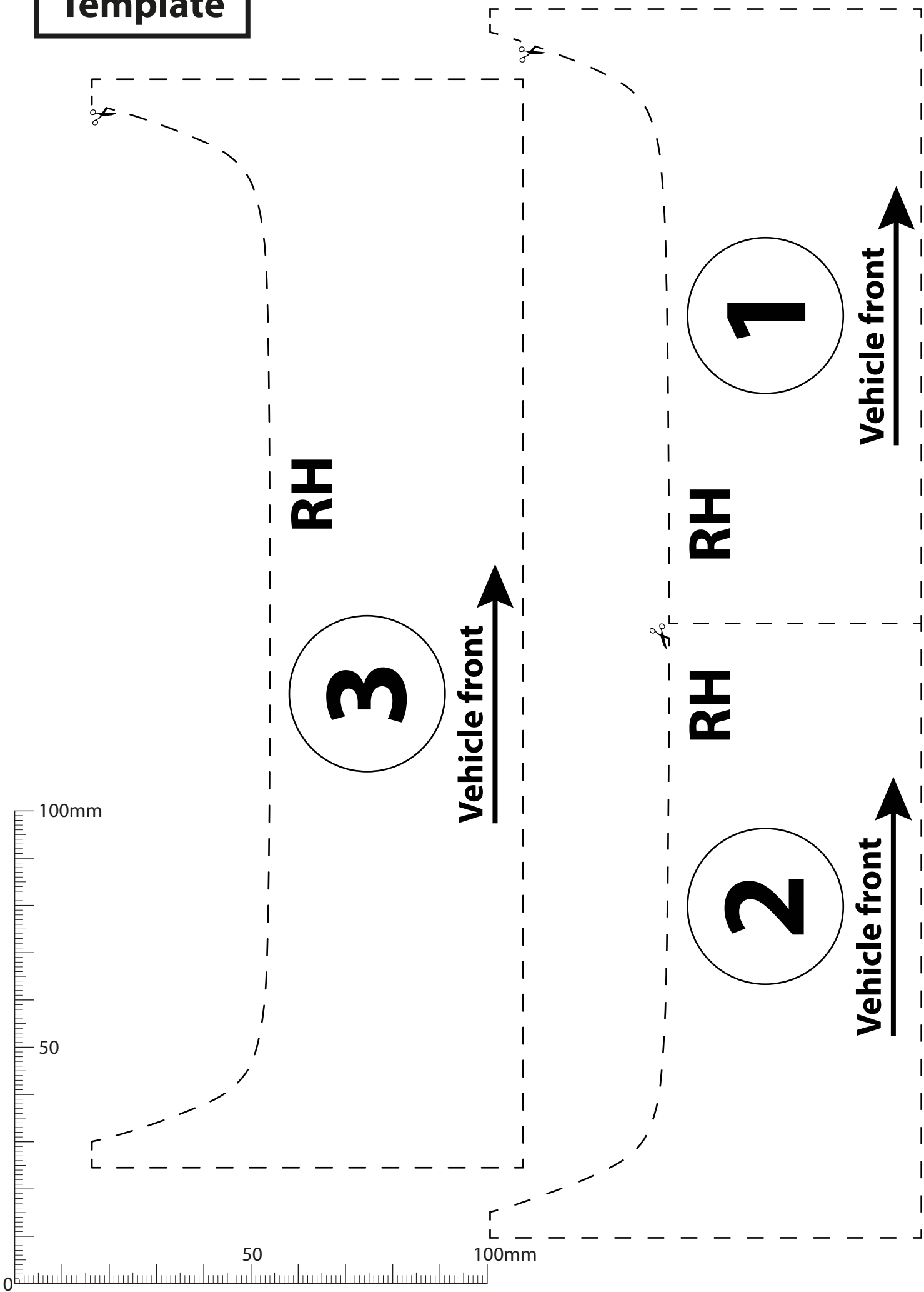

CAUTION; Check above scale to ensure it is 1:1. Adjust on photo copier if not to scale.

Template

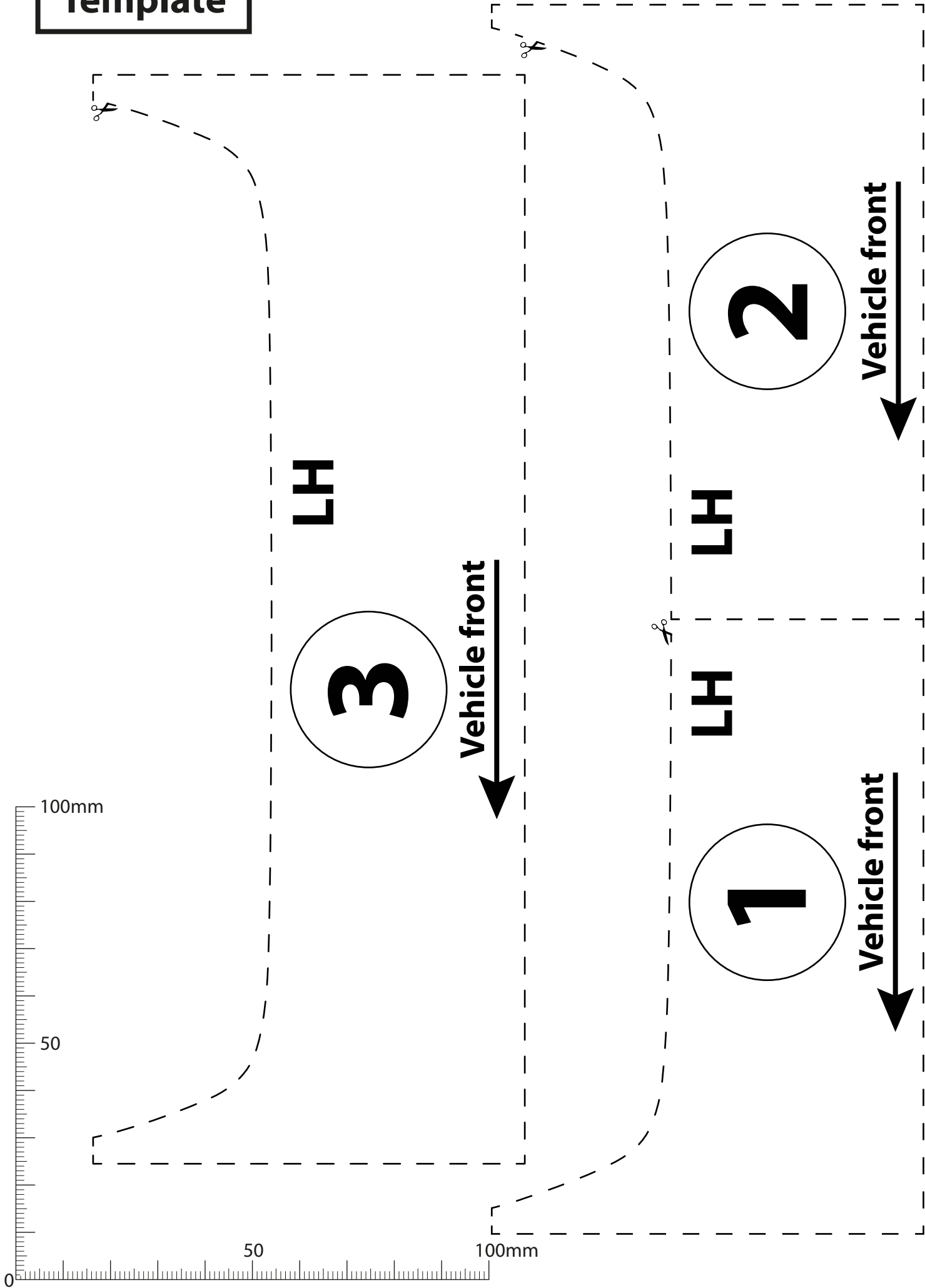

CAUTION; Check above scale to ensure it is 1:1. Adjust on photo copier if not to scale.

