

MAZDA

GB	FLOORMATS Installation instruction
D	FUSSMATTEN Einbauanleitung
E	ALFOMBRILLAS Instrucciones de montaje
F	TAPIS Notice de montage
I	ZERBINI Istruzioni di montaggio
P	CAPACHOS Instruções de montagem
NL	VLOERMATTEN Inbouw-instructie
DK	FODMÅTTER Monteringsvejledning

N	GULVMATTER Monteringsvejledning
S	GOLVMATTOR Monteringsanvisning
SF	MATOT Asennusohje
CZ	ROHOŽKY Návod k montáži
H	PADLÓSZŐNYEGLAP Beszerelési utasítás
PL	DYWANIKI PODŁOGOWE Instrukcja zabudowy
GR	Ταπέτες δαπέδου Οδηγίες τοποθέτησης

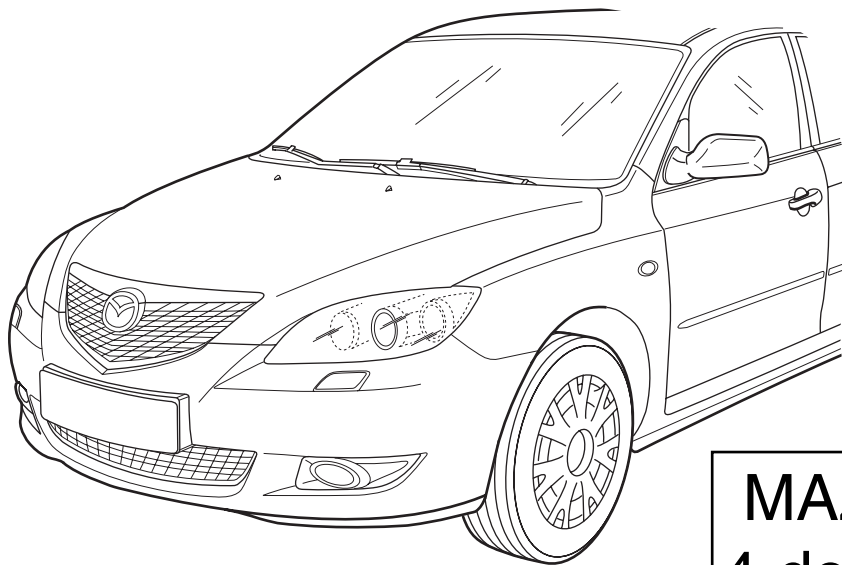

MAZDA 3 BK
4 door / 5 door

Part No: BP4K V0 320, BP5F V0 320,
BP4L V0 320, BP5R V0 320
BP4K V0 351

Date: 20-08-2003

© Copyrights MAZDA / MSX International

Sheet 1 of 3

Subject to alternation without notice
Technische Änderungen vorbehalten
Reservadas modificaciones técnicas
Sous réserve de modifications techniques
Con riserva di apportare modifiche tecniche
Reservamo-nos o direito a alterações técnicas
Technische wijzigingen voorbehouden
Med forbehold for tekniske forandringer
Tekniske forendringer forbeholdes
Med reservation för tekniska ändringar
Tekniset muutokset pidätetään
Technické zmeny vyhrazeny
A változtatások technika jogát fenntartjuk
Zmiany techniczne zastrzeżone
Επιφυλασόμεθα για αλλαγές



- (GB) Movement Arrow
- (D) Bewegungspfeil
- (E) Flecha de movimiento
- (F) Flèche de mouvement
- (I) Freccia di movimento
- (P) Flexa de movimento
- (NL) Richtingspijl
- (DK) Bevægelsespil
- (N) Bevegelsespil
- (S) Rörelsepil
- (SF) Liikesuuntanuoli
- (CZ) Šipka pohybu
- (H) Mozgásirányjelző nyíl
- (PL) Strzałka kierunku ruchu
- (GR) Βέλος κίνησης



- (GB) Location/Position Arrow
- (D) Positionspfeil
- (E) Flecha de posición
- (F) Flèche de Position
- (I) Freccia di posizione
- (P) Flexa de posição
- (NL) Lokatie/Positie pijl
- (DK) Lokaliseringspil
- (N) Posisjonspil
- (S) Positionpil
- (SF) Paikannusnuoli
- (CZ) Šipka na pozici
- (H) Helyzetjelző nyíl
- (PL) Strzałka położenia
- (GR) Βέλος θέσης

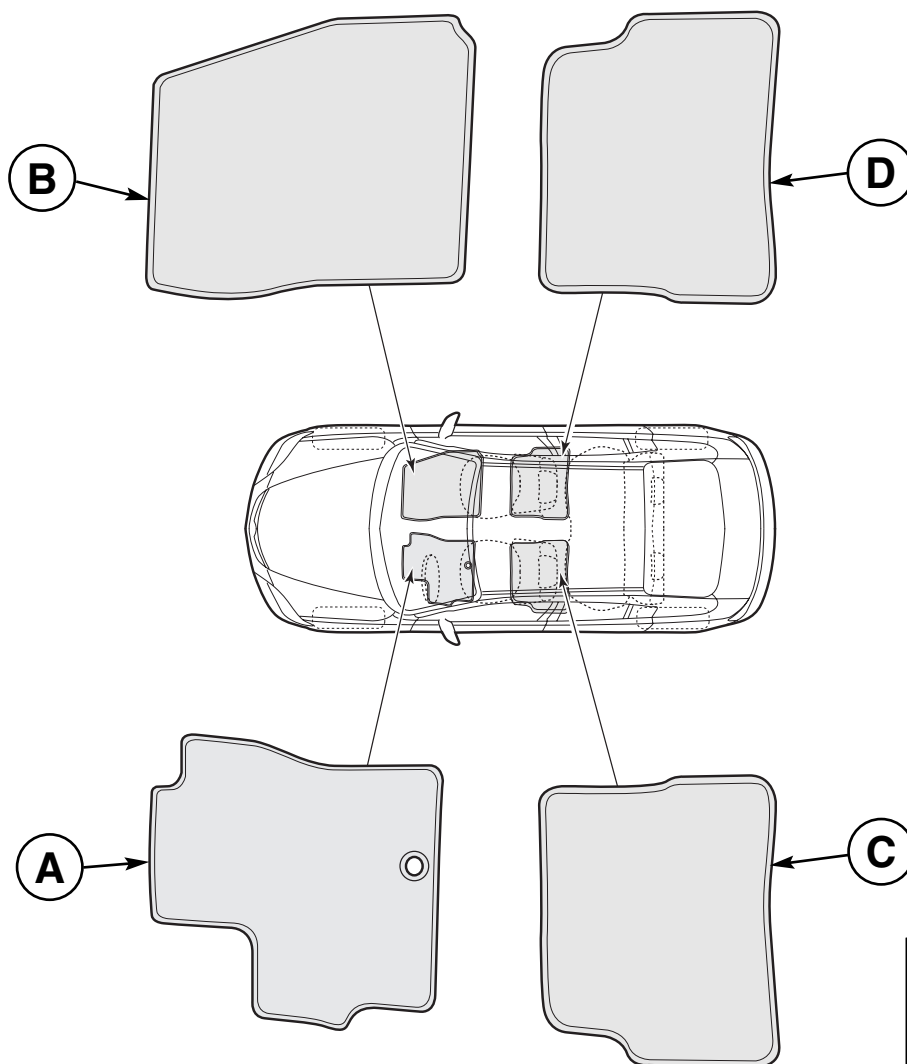

1X

1X

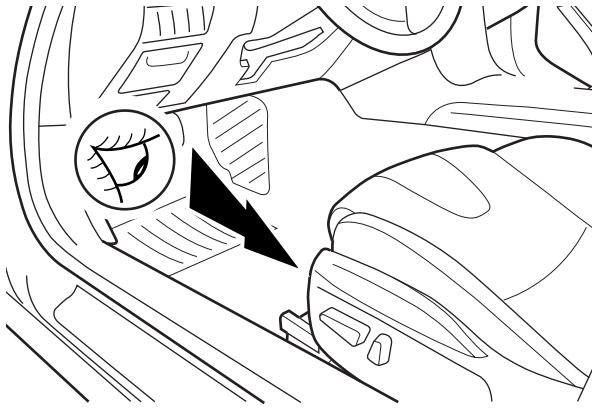

1

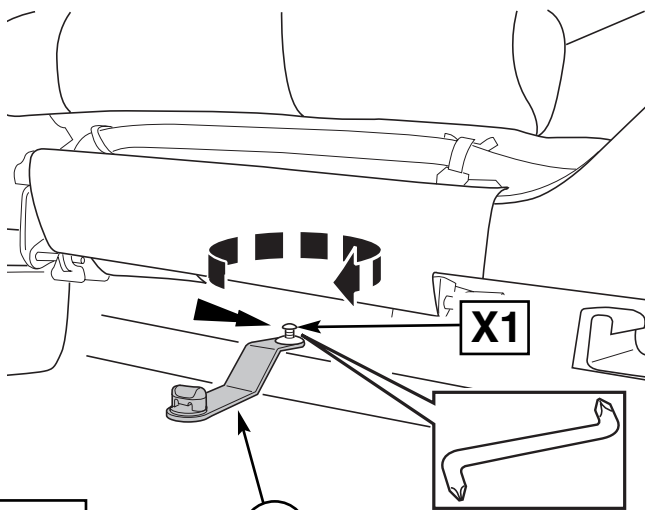
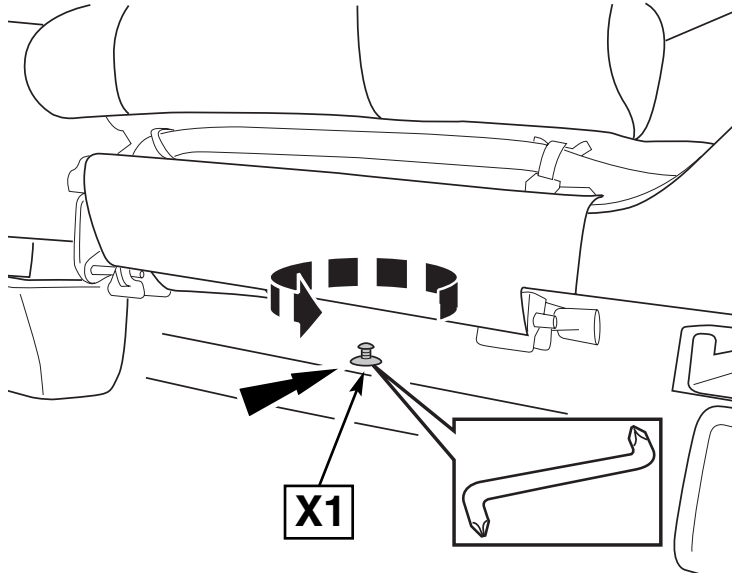

2

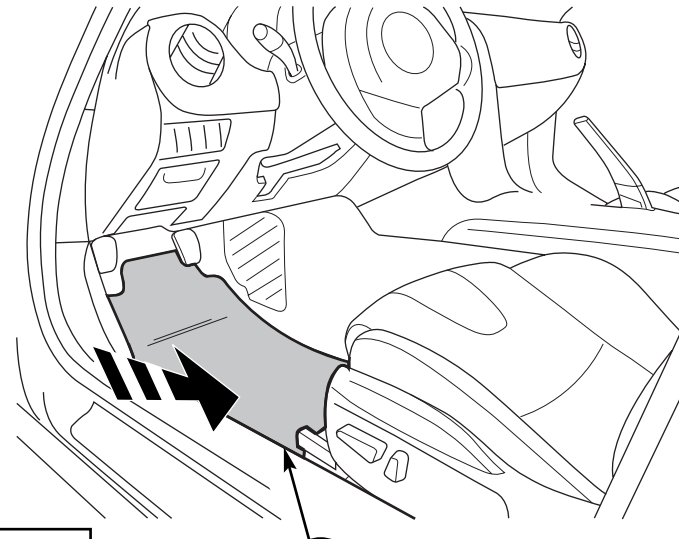

3

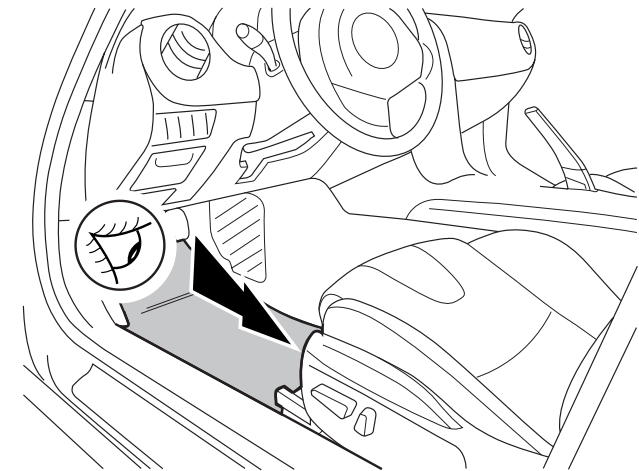

4

