

aprilia

1115-2

00/2002-10

RSV mille

www.serviceaprilia.com

workshop manual



8140688

INTRODUCTION	0
GENERAL INFORMATION	1
SERVICE AND SETTING UP	2
ENGINE	3
FUEL SUPPLY SYSTEM	4
COOLING SYSTEM	5
ELECTRIC SYSTEM	6
CHASSIS	7
REPAIR INFORMATION	8
ANALYTICAL INDEX	<i>i</i>



RSV mille  **1115-2**



workshop manual



aprilias part# 8140688

TABLE OF CONTENTS

0.1 UPDATE OF RELEASE 00/ 2002-10	0-3-00
0.1.1 INFORMATION ON THE UPDATING OF THE MANUAL	0-3-00
0.1.2 UPDATED MANUAL GENERAL LIST ...	0-3-00
0.2 HOW TO CONSULT THE MANUAL	0-5-00
0.3 FOREWORD	0-6-00
0.4 REFERENCE MANUALS	0-6-00
0.4.1 ENGINE SERVICE AND REPAIR MANUALS	0-6-00
0.4.2 SPARE PARTS CATALOGUES	0-6-00
0.4.3 SPECIAL TOOL MANUALS	0-6-00
0.4.4 USE AND MAINTENANCE MANUALS .	0-6-00
0.5 SAFETY WARNINGS	0-7-00
0.5.1 PRECAUTIONS AND GENERAL INFORMATIONS	0-7-00
0.5.2 BEFORE THE DISASSEMBLY OF THE COMPONENTS	0-7-00
0.5.3 DISASSEMBLING THE COMPONENTS	0-7-00
0.5.4 REASSEMBLING THE COMPONENTS	0-7-00
0.6 HOW TO USE YOUR SERVICE AND REPAIR MANUAL	0-8-00
0.6.1 ADVICE FOR CONSULTATION	0-8-00
0.7 ABBREVIATIONS / SYMBOLS / INITIALS	0-9-00

0.1 UPDATE OF RELEASE 00/2002-10

Date of the first edition (Release 00) and of the following Releases:

First edition (Release 00)october 2002

0.1.1 INFORMATION ON THE UPDATING OF THE MANUAL

The manual must be updated every time a new “Release” is received.

Insert the pages of the last Release in the manual and eliminate the corresponding obsolete pages (even if belonging to a previous Release).

⚠ WARNING

The failure to update the manual and to eliminate the obsolete pages makes it more difficult to consult the manual and may lead to the performance of incorrect operations on the vehicle, with serious consequences for the safety of the vehicle and of persons and property.

The manual consists of # 10 sections, for a total amount of # 384 pages, as listed below.

NOTE For the nomenclature of the standard page of the manual (and specifically for the definition of the page number) see 0.2 (HOW TO CONSULT THE MANUAL).

0.1.2 UPDATED MANUAL GENERAL LIST

page#	Release	page#	Release		
0 - 1	-00	00	1 - 25	-00	00
0 - 2	-00	00	1 - 26	-00	00
0 - 3	-00	00	1 - 27	-00	00
0 - 4	-00	00	1 - 28	-00	00
0 - 5	-00	00	1 - 29	-00	00
0 - 6	-00	00	1 - 30	-00	00
0 - 7	-00	00	1 - 31	-00	00
0 - 8	-00	00	1 - 32	-00	00
0 - 9	-00	00	1 - 33	-00	00
0 - 10	-00	00	1 - 34	-00	00
1 - 1	-00	00	1 - 35	-00	00
1 - 2	-00	00	1 - 36	-00	00
1 - 3	-00	00	1 - 37	-00	00
1 - 4	-00	00	1 - 38	-00	00
1 - 5	-00	00	2 - 1	-00	00
1 - 6	-00	00	2 - 2	-00	00
1 - 7	-00	00	2 - 3	-00	00
1 - 8	-00	00	2 - 4	-00	00
1 - 9	-00	00	2 - 5	-00	00
1 - 10	-00	00	2 - 6	-00	00
1 - 11	-00	00	2 - 7	-00	00
1 - 12	-00	00	2 - 8	-00	00
1 - 13	-00	00	2 - 9	-00	00
1 - 14	-00	00	2 - 10	-00	00
1 - 15	-00	00	2 - 11	-00	00
1 - 16	-00	00	2 - 12	-00	00
1 - 17	-00	00	2 - 13	-00	00
1 - 18	-00	00	2 - 14	-00	00
1 - 19	-00	00	2 - 15	-00	00
1 - 20	-00	00	2 - 16	-00	00
1 - 21	-00	00	2 - 17	-00	00
1 - 22	-00	00	2 - 18	-00	00
1 - 23	-00	00	2 - 19	-00	00
1 - 24	-00	00	2 - 20	-00	00

page#	Release	page#	Release		
2 - 21	-00	00	4 - 3	-00	00
2 - 22	-00	00	4 - 4	-00	00
2 - 23	-00	00	4 - 5	-00	00
2 - 24	-00	00	4 - 6	-00	00
2 - 25	-00	00	4 - 7	-00	00
2 - 26	-00	00	4 - 8	-00	00
2 - 27	-00	00	4 - 9	-00	00
2 - 28	-00	00	4 - 10	-00	00
2 - 29	-00	00	4 - 11	-00	00
2 - 30	-00	00	4 - 12	-00	00
2 - 31	-00	00	4 - 13	-00	00
2 - 32	-00	00	4 - 14	-00	00
2 - 33	-00	00	4 - 15	-00	00
2 - 34	-00	00	4 - 16	-00	00
2 - 35	-00	00	4 - 17	-00	00
2 - 36	-00	00	4 - 18	-00	00
2 - 37	-00	00	4 - 19	-00	00
2 - 38	-00	00	4 - 20	-00	00
2 - 39	-00	00	4 - 21	-00	00
2 - 40	-00	00	4 - 22	-00	00
2 - 41	-00	00	4 - 23	-00	00
2 - 42	-00	00	4 - 24	-00	00
2 - 43	-00	00	4 - 25	-00	00
2 - 44	-00	00	4 - 26	-00	00
2 - 45	-00	00	4 - 27	-00	00
2 - 46	-00	00	4 - 28	-00	00
2 - 47	-00	00	4 - 29	-00	00
2 - 48	-00	00	4 - 30	-00	00
2 - 49	-00	00	5 - 1	-00	00
2 - 50	-00	00	5 - 2	-00	00
2 - 51	-00	00	5 - 3	-00	00
2 - 52	-00	00	5 - 4	-00	00
2 - 53	-00	00	5 - 5	-00	00
2 - 54	-00	00	5 - 6	-00	00
2 - 55	-00	00	5 - 7	-00	00
2 - 56	-00	00	5 - 8	-00	00
2 - 57	-00	00	5 - 9	-00	00
2 - 58	-00	00	5 - 10	-00	00
2 - 59	-00	00	5 - 11	-00	00
2 - 60	-00	00	5 - 12	-00	00
2 - 61	-00	00	5 - 13	-00	00
2 - 62	-00	00	5 - 14	-00	00
2 - 63	-00	00	6 - 1	-00	00
2 - 64	-00	00	6 - 2	-00	00
2 - 65	-00	00	6 - 3	-00	00
2 - 66	-00	00	6 - 4	-00	00
3 - 1	-00	00	6 - 5	-00	00
3 - 2	-00	00	6 - 6	-00	00
3 - 3	-00	00	6 - 7	-00	00
3 - 4	-00	00	6 - 8	-00	00
3 - 5	-00	00	6 - 9	-00	00
3 - 6	-00	00	6 - 10	-00	00
3 - 7	-00	00	6 - 11	-00	00
3 - 8	-00	00	6 - 12	-00	00
3 - 9	-00	00	6 - 13	-00	00
3 - 10	-00	00	6 - 14	-00	00
3 - 11	-00	00	6 - 15	-00	00
3 - 12	-00	00	6 - 16	-00	00
3 - 13	-00	00	6 - 17	-00	00
3 - 14	-00	00	6 - 18	-00	00
3 - 15	-00	00	6 - 19	-00	00
3 - 16	-00	00	6 - 20	-00	00
3 - 17	-00	00	6 - 21	-00	00
3 - 18	-00	00	6 - 22	-00	00
3 - 19	-00	00	6 - 23	-00	00
3 - 20	-00	00	6 - 24	-00	00
3 - 21	-00	00	6 - 25	-00	00
3 - 22	-00	00	6 - 26	-00	00
4 - 1	-00	00	6 - 27	-00	00
4 - 2	-00	00	6 - 28	-00	00

Follow ▶

Follow ▶

page#	Release	page#	Release	page#	Release
6 - 29 - 00	00	7 - 45 - 00	00	8 - 1 - 00	00
6 - 30 - 00	00	7 - 46 - 00	00	8 - 2 - 00	00
6 - 31 - 00	00	7 - 47 - 00	00	8 - 3 - 00	00
6 - 32 - 00	00	7 - 48 - 00	00	8 - 4 - 00	00
6 - 33 - 00	00	7 - 49 - 00	00	8 - 5 - 00	00
6 - 34 - 00	00	7 - 50 - 00	00	8 - 6 - 00	00
6 - 35 - 00	00	7 - 51 - 00	00	8 - 7 - 00	00
6 - 36 - 00	00	7 - 52 - 00	00	8 - 8 - 00	00
6 - 37 - 00	00	7 - 53 - 00	00	8 - 9 - 00	00
6 - 38 - 00	00	7 - 54 - 00	00	8 - 10 - 00	00
6 - 39 - 00	00	7 - 55 - 00	00	8 - 11 - 00	00
6 - 40 - 00	00	7 - 56 - 00	00	8 - 12 - 00	00
6 - 41 - 00	00	7 - 57 - 00	00	8 - 13 - 00	00
6 - 42 - 00	00	7 - 58 - 00	00	8 - 14 - 00	00
6 - 43 - 00	00	7 - 59 - 00	00	8 - 15 - 00	00
6 - 44 - 00	00	7 - 60 - 00	00	8 - 16 - 00	00
6 - 45 - 00	00	7 - 61 - 00	00	8 - 17 - 00	00
6 - 46 - 00	00	7 - 62 - 00	00	8 - 18 - 00	00
6 - 47 - 00	00	7 - 63 - 00	00	8 - 19 - 00	00
6 - 48 - 00	00	7 - 64 - 00	00	8 - 20 - 00	00
6 - 49 - 00	00	7 - 65 - 00	00	8 - 21 - 00	00
6 - 50 - 00	00	7 - 66 - 00	00	8 - 22 - 00	00
6 - 51 - 00	00	7 - 67 - 00	00	8 - 23 - 00	00
6 - 52 - 00	00	7 - 68 - 00	00	8 - 24 - 00	00
6 - 53 - 00	00	7 - 69 - 00	00	② - 1 - 00	00
6 - 54 - 00	00	7 - 70 - 00	00	② - 2 - 00	00
7 - 1 - 00	00	7 - 71 - 00	00	② - 3 - 00	00
7 - 2 - 00	00	7 - 72 - 00	00	② - 4 - 00	00
7 - 3 - 00	00	7 - 73 - 00	00	② - 5 - 00	00
7 - 4 - 00	00	7 - 74 - 00	00	② - 6 - 00	00
7 - 5 - 00	00	7 - 75 - 00	00	② - 7 - 00	00
7 - 6 - 00	00	7 - 76 - 00	00	② - 8 - 00	00
7 - 7 - 00	00	7 - 77 - 00	00	② - 9 - 00	00
7 - 8 - 00	00	7 - 78 - 00	00	② - 10 - 00	00
7 - 9 - 00	00	7 - 79 - 00	00	② - 11 - 00	00
7 - 10 - 00	00	7 - 80 - 00	00	② - 12 - 00	00
7 - 11 - 00	00	7 - 81 - 00	00		
7 - 12 - 00	00	7 - 82 - 00	00		
7 - 13 - 00	00	7 - 83 - 00	00		
7 - 14 - 00	00	7 - 84 - 00	00		
7 - 15 - 00	00	7 - 85 - 00	00		
7 - 16 - 00	00	7 - 86 - 00	00		
7 - 17 - 00	00	7 - 87 - 00	00		
7 - 18 - 00	00	7 - 88 - 00	00		
7 - 19 - 00	00	7 - 89 - 00	00		
7 - 20 - 00	00	7 - 90 - 00	00		
7 - 21 - 00	00	7 - 91 - 00	00		
7 - 22 - 00	00	7 - 92 - 00	00		
7 - 23 - 00	00	7 - 93 - 00	00		
7 - 24 - 00	00	7 - 94 - 00	00		
7 - 25 - 00	00	7 - 95 - 00	00		
7 - 26 - 00	00	7 - 96 - 00	00		
7 - 27 - 00	00	7 - 97 - 00	00		
7 - 28 - 00	00	7 - 98 - 00	00		
7 - 29 - 00	00	7 - 99 - 00	00		
7 - 30 - 00	00	7 - 100 - 00	00		
7 - 31 - 00	00	7 - 101 - 00	00		
7 - 32 - 00	00	7 - 102 - 00	00		
7 - 33 - 00	00	7 - 103 - 00	00		
7 - 34 - 00	00	7 - 104 - 00	00		
7 - 35 - 00	00	7 - 105 - 00	00		
7 - 36 - 00	00	7 - 106 - 00	00		
7 - 37 - 00	00	7 - 107 - 00	00		
7 - 38 - 00	00	7 - 108 - 00	00		
7 - 39 - 00	00	7 - 109 - 00	00		
7 - 40 - 00	00	7 - 110 - 00	00		
7 - 41 - 00	00	7 - 111 - 00	00		
7 - 42 - 00	00	7 - 112 - 00	00		
7 - 43 - 00	00	7 - 113 - 00	00		
7 - 44 - 00	00	7 - 114 - 00	00		

0.2 HOW TO CONSULT THE MANUAL

1

RSV mille

2

GENERAL INFORMATION

8

1.8 POSITIONING THE VEHICLE ON THE SUPPORT STAND

9

1.8.1 ASSEMBLING THE PINS FOR THE REAR SUPPORT STAND **OPT**

10

NOTE Have the appropriate special tool **OPT** to hand:
 - **aprilia** part# xxxxxxx N.A. [centre stand].

11

- ◆ Position the vehicle on the side stand on firm and level ground.
- ◆ ★ Position the pin (1) on the appropriate seat on the rear fork.
- ◆ ★ Screw and tighten the screw (2) in the appropriate threaded hole in the rear fork.

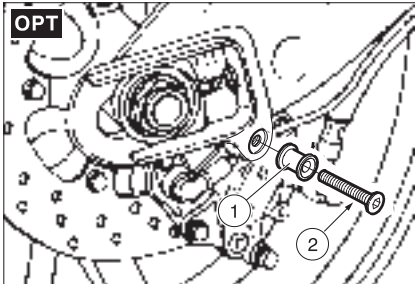

1.8.2 POSITIONING THE VEHICLE ON THE REAR SUPPORT STAND **OPT**

NOTE Have the appropriate special tool **OPT** to hand:
 - **aprilia** part# xxxxxxx N.A. [centre stand].

- ◆ Fit the relevant pins, see 1.8.1 (ASSEMBLING THE PINS FOR THE REAR SUPPORT STAND **OPT**).

NOTE Have someone help you keep the vehicle in vertical position with the two wheels on the ground.

- ◆ ★ Loosen the knob (3).
- ◆ ★ Move the fork support (4), positioning it so that the width corresponds to the distance between the two pins (1) on the rear fork.
- ◆ ★ Tighten the knob (3).
- ◆ At the same time introduce the two fork-shaped seats (4) of the stand (5) under the two pins (1) provided on the vehicle.

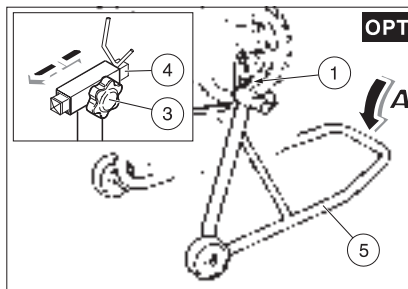

CAUTION

Grasping the stand in another way than indicated in the figure may cause your fingers to be crushed between the stand and the ground.

- ◆ Grasp the terminal central part of the stand (5) with your hands (Pos.A).
- ◆ Push the stand (5) downwards until it reaches the end of its stroke.

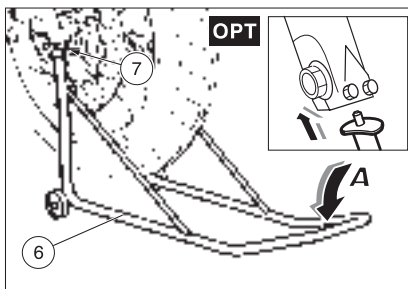

1.8.3 POSITIONING THE VEHICLE ON THE FRONT SUPPORT STAND **OPT**

NOTE Have the appropriate special tool **OPT** to hand:
 - **aprilia** part# 8146486 (front support stand).

- ◆ Position the vehicle on the appropriate rear support stand, see 1.8.2 (POSITIONING THE VEHICLE ON THE REAR SUPPORT STAND **OPT**).
- ◆ Insert the two ends of the stand (6) in the two holes (7) positioned on the lower ends of the front fork.



- 1) Vehicle (or engine) model
- 2) Section
- 3) Release consecutive number ("00" indicates the first edition)
- 4) Year and month of publication of the Release
- 5) Section number
- 6) Section page consecutive number

- 7) Updated page consecutive number
- 8) Chapter title (numbered consecutively)
- 9) Paragraph title (numbered consecutively)
- 10) Description of the operation (always preceded by a rhombus)
- 11) Description of the operation: the star means that the operation must be repeated on the other side of the vehicle

0.3 FOREWORD

- This manual supplies the main information for normal servicing procedures.
- In the future, the information and illustrations that make up this manual will be updated by means of "Releases", see 0.1 (UPDATE OF RELEASE 00/2002-10).
- This publication is intended for the **aprilia** Dealers and their qualified engineers; many notions were voluntarily omitted, because they were considered superfluous. Since it is not possible to include complete mechanical information in this publication, the persons using this manual must have a basic mechanical training and a basic knowledge of the procedures regarding motor vehicles repair systems.

Without this knowledge, the repair or servicing of the vehicle may be ineffective or even dangerous.

The manual does not describe all the procedures for the repair and servicing of the vehicle in detail, therefore it is important to be particularly careful, in order to avoid any damage to components and persons.

In order to grant its customers more and more satisfaction in the use of the vehicle, **aprilia s.p.a.** will keep improving its products and the relevant documentation.

The main technical modifications and the modifications in the vehicle repair procedures are communicated to all **aprilia** Outlets and Branches the world over. These modifications will be described in the successive editions of this manual.

In case of need or doubts regarding the repair and inspection procedures, contact the Technical After-Sales Dpt., which can give you the information required and also inform you about any updates and technical modifications made to the vehicle.

aprilia s.p.a. reserves the right to modify its models at any time, without prejudice to the main characteristics here described.

All rights as to electronic storage, reproduction and total or partial adaptation, with any means, are reserved for all Countries.

The mention to products or services supplied by third parties is made only for information purposes and it isn't binding in any case.

aprilia takes no responsibility as to the performance or use of said products.

For further information, see 0.4 (REFERENCE MANUALS).

First edition: october 2002

Prodotto e stampato da:
stp editing division
 Soave (VERONA) - Italia
 tel. +39 045.7611911
 fax +39 045.7612241
 E-mail: customer@stp.it
 www.stp.it

per conto di:
aprilia s.p.a.
 Technical After-Sales Department - Technical Documentation Department
 via G. Galilei, 1 - 30033 Noale (VE) - Italia
 tel. +39 041.5829111
 fax +39 041.5829190
 www.aprilia.com
 www.serviceaprilia.com

0.4 REFERENCE MANUALS**0.4.1 ENGINE SERVICE AND REPAIR MANUALS**

aprilia part# (countries)
8140582 (1051-1) I
8140584 (1053-1) F
8140585 (1054-1) D
8140583 (1052-1) E
8140586 (1055-1) UK
8140587 (1056-1) USA

0.4.2 SPARE PARTS CATALOGUES

aprilia part# (countries)
390W I UK
390Y I UK
3901 I UK

0.4.3 SPECIAL TOOL MANUALS

aprilia part# (countries)
8202278 I F D E UK

0.4.4 USE AND MAINTENANCE MANUALS

aprilia part# (countries)
models 1998 - 1999
8102623 I F D
8102857 P E UK
8102858 NL DK SF
8102859 GR J UK
8104128 AUS
8104099 USA
models 2000
8104089 I F D
8104142 P E UK
8104143 NL DK SF
8104141 GR J UK
8104164 AUS
8104171 USA
RSV 01
8104152 I F D
8104269 P E UK
8104267 NL DK SF
8104268 GR J UK
8104270 AUS
8104264 USA

0.5 SAFETY WARNINGS

The following precautionary warnings are used throughout this manual in order to convey the following messages:

⚠ Safety warning. When you find this symbol on the vehicle or in the manual, be careful to the potential risk of personal injury. Non-compliance with the indications given in the messages preceded by this symbol may result in grave risks for your and other people's safety and for the vehicle!

⚠ WARNING

Indicates a potential hazard which may result in serious injury or even death.

⚠ CAUTION

Indicates a potential hazard which may result in minor personal injury or damage to the vehicle.

NOTE The word "NOTE" in this manual precedes important information or instructions.

0.5.1 PRECAUTIONS AND GENERAL INFORMATION

Follow with care these recommendations when repairing, disassembling and reassembling the vehicle.

⚠ WARNING

The use of naked flames is forbidden for any type of operation.

Before beginning any maintenance operation or any inspection of the vehicle, stop the engine, extract the key from the ignition block, wait until the engine and the exhaust system have cooled down and if possible lift the vehicle by means of the proper equipment, on firm and flat ground.

Keep away from the red-hot parts of the engine and of the exhaust system, in order to avoid burns.

⚠ WARNING

Do not hold any mechanical piece or other parts of the vehicle with your mouth: the components are not edible and some of them are noxious or even toxic.

If not expressly indicated otherwise, for the reassembly of the units repeat the disassembly operations in reverse order.

Any reference to operations from other chapters must be interpreted logically in order to avoid components being removed unnecessarily.

Do not use polishing pastes on matt paints.

Never use fuel as a solvent for cleaning the vehicle.

Do not use alcohol, petrol or solvents to clean the rubber and plastic parts and the saddle: use only water and mild soap.

Disconnect the negative cable (-) from the battery when electric welding.

When two or more persons are working together, make sure that each is working in safe conditions.

Carefully read 1.2 (INSTRUCTIONS FOR USE OF FUEL, LUBRICANTS, COOLANT AND OTHER COMPONENTS).

0.5.2 BEFORE THE DISASSEMBLY OF THE COMPONENTS

- Remove any dirt, mud, dust and foreign matters from the vehicle before disassembling the components.
- Use, when necessary, the special tools designed for this vehicle.

0.5.3 DISASSEMBLING THE COMPONENTS

- Do not loosen and/or tighten the screws and nuts using pliers or other tools: instead, always use the proper spanner.
- Before disconnecting the joints (pipes, cables, etc.), mark the positions on all of them and mark them with different distinguishing signs. Each piece must be marked clearly, in order not to have problems during installation.
- Clean and wash carefully any disassembled parts with low inflammability detergents.
- Keep the parts that are used in pairs together, since they have adapted to each other following the normal wear. Some components must be used together or replaced completely.
- Keep away from heat sources.

0.5.4 REASSEMBLING THE COMPONENTS

⚠ CAUTION

Never use a seeger ring twice. When a seeger ring is removed, it must be replaced with a new one. When assembling a new seeger ring be careful not to stretch its ends more than strictly necessary to put it on the shaft.

After installing a seeger ring, make sure that it is completely and firmly inserted in its seat.

Do not use compressed air to clean the bearings.

NOTE The bearings must rotate freely, without halting a/o noise otherwise they must be replaced.

- Use only original **aprilia** SPARE PARTS.
- Use the recommended lubricants.
- Whenever possible, lubricate the parts before reassembly.
- When tightening screws and nuts, begin with those having greater diameters or with inner ones, proceeding diagonally. Tighten screws or nuts in successive passages before applying driving torque.
- Always replace lock nuts, seals, sealing rings, snap rings, O-rings, split pins and screws, whenever the thread appears damaged, with new ones.
- Before the assembly, clean all the connection surfaces, the oil seal edges and the gaskets. Apply a thin layer of lithium-based grease on the oil seal edges. Put back the oil seals and the bearings with the mark or serial number facing towards the outside (visible side).

Follow ►

Follow ►

- When installing the bearings, lubricate them abundantly.
- Make sure that each component has been reassembled correctly.
- After a repair or periodic maintenance operation, carry out the preliminary checks and test the vehicle in a private area or, in any case, in a low-traffic area.

0.6 HOW TO USE YOUR SERVICE AND REPAIR MANUAL

0.6.1 ADVICE FOR CONSULTATION

- This manual is divided into section and chapters, each one of which corresponds to a category of main components.
To consult them, see the sections' index, see page 0-1.
- If not expressly indicated otherwise, for the reassembly of the units repeat the disassembly operations in reverse order.
- The terms "right" and "left" are referred to the rider seated on the vehicle in the normal riding position.
- For normal maintenance operations and for the use of the vehicle, consult the "USE AND MAINTENANCE" manual.

★ **The operations preceded by this symbol must be repeated on the opposite side of the vehicle.**

In this manual the various versions are indicated by the following symbols:

- RSV 01** frame # ZD4RP.....(and in any case from model 2001)
- ASD** automatic light switching version (Automatic Switch-on Device)
- OPT** optional
- ✿** catalytic version

VERSION:

- | | | |
|--------------------------|------------------------|-------------------------------------|
| I Italy | GR Greece | MAL Malaysia |
| UK United Kingdom | NL Holland | RCH Chile |
| A Austria | CH Switzerland | HR Croatia |
| P Portugal | DK Denmark | AUS Australia |
| SF Finland | J Japan | USA United States of America |
| B Belgium | SGP Singapore | BR Brazil |
| D Germany | SLO Slovenia | RSA South Africa |
| F France | IL Israel | NZ New Zealand |
| E Spain | ROK South Korea | CDN Canada |

0.7 ABBREVIATIONS / SYMBOLS / INITIALS

#	= number	PICK-UP	= pick-up
<	= is less than	BDC	= bottom dead centre
>	= is greater than	TDC	= top dead centre
≤	= is equal to or less than	PPC	= Pneumatic Power Clutch
≥	= is equal to or greater than	RIGHT SIDE	= right side
~	= approximately	SAE	= Society of Automotive Engineers
∞	= infinity	TEST	= diagnostics test
°C	= degrees Celsius (centigrade)	T.B.E.I.	= convex socket head
°F	= degrees Fahrenheit	T.C.E.I.	= hexagonal socket head
±	= plus or minus	T.E.	= hex-head
a.c.	= alternating current	T.P.	= flat head
A	= ampère	TSI	= Twin Spark Ignition
Ah	= ampere per hour	UPSIDE-DOWN	= upside-down rods
API	= American Petroleum Institute	V	= volt
HV	= high voltage	W	= watt
AV/DC	= AntiVibration Double Countershaft	∅	= diameter
bar	= unit of pressure (1 bar = 100 kPa)		
d.c.	= direct current		
cm³	= cubic centimetres		
CO	= carbon monoxide		
CPU	= Central Processing Unit		
DIN	= German industrial normative (Deutsche Industrie Norm)		
DOHC	= Double Overhead Camshaft		
ECU	= Engine Control Unit		
rpm	= revolutions per minute		
HC	= unburnt hydrocarbons		
ISC	= idle speed control		
ISO	= International Standardization Organization		
kg	= kilograms		
kgm	= kilograms per metre (1 kgm = 10 Nm)		
km	= kilometres		
km/h	= kilometres an hour		
kΩ	= kilo-ohms		
kPa	= kiloPascal (1 kPa = 0.01 bar)		
KS	= clutch side (Kupplungseite)		
kW	= kilowatt		
ℓ	= litres		
LAP	= lap (race course)		
LED	= Light Emitting Diode		
LEFT SIDE	= left side		
m/s	= metres an second		
MAX	= maximum		
mbar	= millibar (1 mbar = 0.1 kPa)		
mi	= mile		
MIN	= minimum		
MPH	= miles per hour		
MS	= flywheel side (Magnetoseite)		
MΩ	= megaohm		
N.A.	= not available (Not Available)		
N.O.M.M.	= "Motor" method octane number		
N.O.R.M.	= "Research" method octane number		
Nm	= newton per meter (1 Nm = 0.1 kgm)		
Ω	= ohm		

GENERAL INFORMATION

1

GENERAL INFORMATION

1.11 INSTRUCTIONS FOR APPLYING TRANSFERS 1-36-00

1

TABLE OF CONTENTS

1.1 POSITION OF THE SERIAL NUMBERS 1-3-00

1.1.1 FRAME NUMBER 1-3-00

1.1.2 ENGINE NUMBER 1-3-00

1.2 INSTRUCTIONS FOR USE OF FUEL, LUBRICANTS, COOLANT AND OTHER COMPONENTS 1-4-00

1.2.1 FUEL 1-4-00

1.2.2 ENGINE OIL 1-4-00

1.2.3 FORK OIL 1-4-00

1.2.4 BRAKE FLUID 1-5-00

1.2.5 COOLANT 1-5-00

1.2.6 CLUTCH FLUID 1-6-00

1.2.7 CARBON MONOXIDE 1-6-00

1.2.8 HOT COMPONENTS 1-6-00

1.3 RUNNING-IN RULES 1-7-00

1.4 SPARE PARTS 1-7-00

1.5 TECHNICAL SPECIFICATIONS 1-8-00

1.6 LUBRICANT CHART 1-12-00

1.6.1 LUBRICANT CHART (for models up to 2001) 1-12-00

1.6.2 LUBRICANT CHART **RSV 01** 1-13-00

1.7 SPECIAL TOOLS **OPT** 1-14-00

1.7.1 SUPPORT STANDS 1-14-00

1.7.2 FRAME TOOLS 1-15-00

1.7.3 FORK TOOLS 1-15-00

1.7.4 ENGINE TOOLS 1-16-00

1.7.5 MISCELLANEOUS TOOLS 1-18-00

1.7.6 TOOLS USED FOR OTHER aprilia VEHICLES 1-20-00

1.8 POSITIONING THE VEHICLE ON THE SUPPORT STAND 1-21-00

1.8.1 ASSEMBLING THE PINS FOR THE REAR SUPPORT STAND **OPT** 1-21-00

1.8.2 POSITIONING THE VEHICLE ON THE REAR SUPPORT STAND **OPT** 1-21-00

1.8.3 POSITIONING THE VEHICLE ON THE FRONT SUPPORT STAND **OPT** 1-21-00

1.8.4 POSITIONING THE VEHICLE ON THE CENTRE SUPPORT STAND **OPT** 1-22-00

1.9 CONSUMABLES 1-23-00

1.9.1 PRODUCT PROPERTIES 1-23-00

1.9.2 USE OF CONSUMABLES 1-25-00

1.10 FASTENING ELEMENTS 1-28-00

1.10.1 JOINTS WITH HOSE CLAMPS AND SCREW CLAMPS 1-28-00

1.10.2 GENERAL SPECIFICATIONS OF THE DRIVING TORQUES 1-29-00

1.10.3 DRIVING TORQUES 1-30-00

1.1 POSITION OF THE SERIAL NUMBERS

These numbers are necessary for the registration of the vehicle.

Do not alter the identification numbers if you do not want to incur severe penal and administrative sanctions. In particular, the alteration of the frame number results in the immediate invalidity of the guarantee.

1.1.1 FRAME NUMBER

The frame number is stamped on the right side of the steering column.

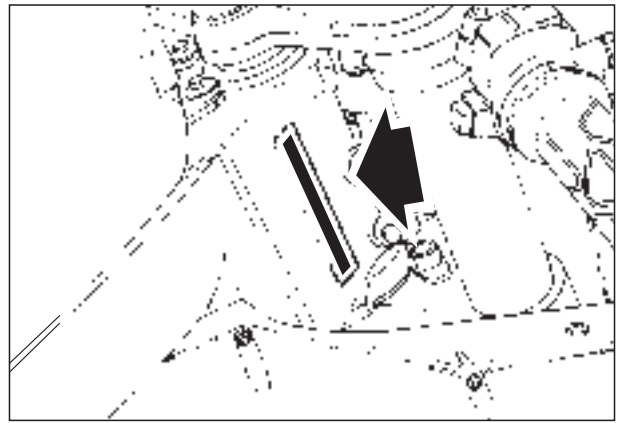

1.1.2 ENGINE NUMBER

The engine number is stamped on the rear part of the engine, near the pinion.

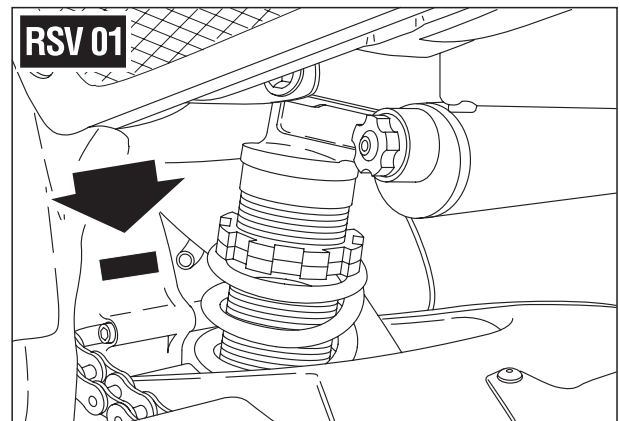
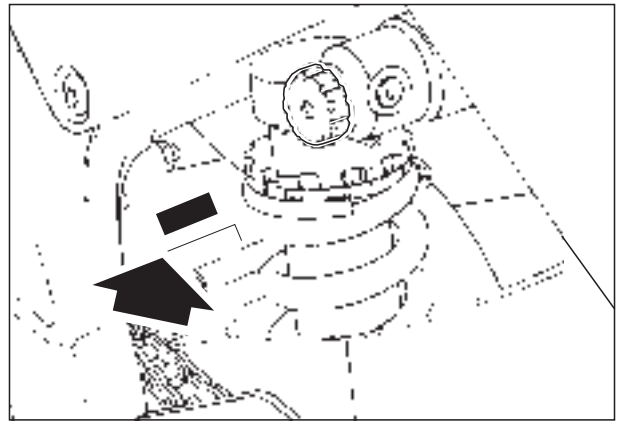

1.2 INSTRUCTIONS FOR USE OF FUEL, LUBRICANTS, COOLANT AND OTHER COMPONENTS

1.2.1 FUEL

⚠ WARNING

The fuel used for internal combustion engines is extremely inflammable and in particular conditions it can become explosive.

It is important to carry out the refuelling and the maintenance operations in a well-ventilated area, with the engine off.

Do not smoke while refuelling or near fuel vapours, in any case avoid any contact with naked flames, sparks and any other heat source to prevent the fuel from catching fire or from exploding.

Further, prevent fuel from flowing out of the fuel filler, as it could catch fire when getting in contact with the red-hot surfaces of the engine.

In case some fuel has accidentally been spilt, make sure that the area has completely dried and before starting the vehicle verify that there is no fuel inside the fuel filler neck.

Since petrol expands under the heat of the sun and due to the effects of sun radiation.

Never fill the tank to the brim.

Screw the plug up carefully after refuelling.

Avoid any contact of the fuel with the skin and the inhalation of vapours; do not swallow fuel or pour it from a receptacle into another by means of a tube.

DO NOT DISPOSE OF FUEL IN THE ENVIRONMENT.

KEEP AWAY FROM CHILDREN.

Use only premium grade unleaded petrol, min. O.N. 95 (N.O.R.M.) and 85 (N.O.M.M.).

1.2.2 ENGINE OIL

⚠ WARNING

Engine oil may cause serious damage to the skin if handled daily and for long periods.

Wash your hands carefully after use.

Do not dispose of the oil in the environment.

Deliver it to or have it collected by the nearest oil salvage center or by the supplier.

In case any maintenance operation has to be carried out, it is advisable to use latex gloves.

For the maintenance intervals, see 2.1.1 (REGULAR SERVICE INTERVALS CHART).

For the lubricant types, see 1.6 (LUBRICANT CHART).

1.2.3 FORK OIL

⚠ WARNING

Fork oil may cause serious damage to the skin if handled daily and for long periods.

Wash your hands carefully after use.

Do not dispose of the oil in the environment.

Deliver it to or have it collected by the nearest oil salvage center or by the supplier.

In case any maintenance operation has to be carried out, it is advisable to use latex gloves.

By changing the damper settings and/or the viscosity of the oil contained in them, the suspension response may be altered partially.

Standard oil viscosity: SAE 20 W.

The viscosity ratings which can be chosen based on the type of fork stiffness desired (SAE 5W soft, 20W stiff).

The two products can be used in different percentages until the desired response is obtained.

F.A. is that your viscosity alters little with changes in temperature and their damping response therefore remains constant.

For the maintenance intervals, see 2.1.1 (REGULAR SERVICE INTERVALS CHART).

For the lubricant types, see 1.6 (LUBRICANT CHART).

1.2.4 BRAKE FLUID

NOTE This vehicle is provided with front and rear disc brakes, with separate hydraulic circuits. The following information refers to a single braking system, but is valid for both.

⚠ WARNING

If the brake fluid gets in contact with the skin or the eyes, it can cause serious irritations.

Carefully wash the parts of your body that get in contact with the liquid. Consult a doctor or an oculist if the liquid gets in contact with your eyes.

DO NOT DISPOSE OF THE FLUID IN THE ENVIRONMENT.

KEEP AWAY FROM CHILDREN.

When using the brake fluid, take care not to spill it on the plastic or painted parts, since it can damage them.

For the maintenance intervals, see 2.1.1 (REGULAR SERVICE INTERVALS CHART).

For the lubricant types, see 1.6 (LUBRICANT CHART).

⚠ CAUTION

To avoid serious damage to the braking system, do not use fluids other than the recommended ones nor mix different fluids for topping up.

Do not use brake fluid taken from old or already opened containers.

Sudden variations in clearance or an elastic resistance in the brake levers may be due to trouble in the hydraulic circuits.

Make sure that the brake discs and the friction pads are completely free of grease or oil, especially after maintenance or checking operations.

Check that the brake cables are neither twisted nor worn out.

Prevent water or dust from accidentally getting into the circuit.

In case maintenance operations are to be performed on the hydraulic circuit, it is advisable to use latex gloves.

1.2.5 COOLANT

⚠ WARNING

The coolant is noxious: do not swallow it; if the coolant gets in contact with the skin or the eyes, it can cause serious irritations. If the coolant gets in contact with your skin or eyes, rinse with plenty of water and consult a doctor.

If it is swallowed, induce vomit, rinse mouth and throat with plenty of water and consult a doctor without delay.

DO NOT DISPOSE OF THE FLUID IN THE ENVIRONMENT.

KEEP AWAY FROM CHILDREN.

Be careful not to spill the coolant on the red-hot parts of the engine: it may catch fire and send out invisible flames.

In case any maintenance operation should be required, it is advisable to use latex gloves.

Do not use the vehicle if the coolant is below the minimum prescribed level.

For the maintenance intervals, see 2.1.1 (REGULAR SERVICE INTERVALS CHART).

The coolant is composed of 50% water and 50% anti-freeze. This mixture is ideal for most running temperatures and ensures good protection against corrosion.

It is advisable to keep the same mixture in the hot season as well, since in this way losses due to evaporation are reduced and it is not necessary to top up so frequently.

The mineral salt deposits left in the radiator by evaporated water are thus lessened and the efficiency of the cooling system remains unaltered.

If the outdoor temperature is below 0°, check the cooling circuit frequently and if necessary increase the anti-freeze concentration (up to maximum 60%).

For the cooling solution use distilled water, in order not to damage the engine.

For the lubricant types, see 1.6 (LUBRICANT CHART).

On the basis of the desired freezing temperature of the coolant mixture, add to the water the percentage of coolant indicated in the following table:

Freezing point °C	Coolant of the volume %
-20	35
-30	45
-40	55

NOTE The characteristics of the various antifreeze liquids are different. Be sure to read the label on the product to learn the degree of protection it guarantees.

⚠ CAUTION

Use only antifreeze and anticorrosive without nitrite, ensuring protection at -35 °C at least.

1.2.6 CLUTCH FLUID

NOTE This vehicle is provided with hydraulic clutch control.

⚠ WARNING

If the clutch fluid gets in contact with the skin or the eyes, it can cause serious irritations. Carefully wash the parts of your body that get in contact with the liquid. Consult a doctor or an oculist if the liquid gets in contact with your eyes.

DO NOT DISPOSE OF THE FLUID IN THE ENVIRONMENT.

KEEP AWAY FROM CHILDREN.

When using the clutch fluid, take care not to spill it on the plastic and painted parts, since it damages them.

For the maintenance intervals, see 2.1.1 (REGULAR SERVICE INTERVALS CHART).

For the lubricant types, see 1.6 (LUBRICANT CHART).

⚠ CAUTION

To avoid serious damage to the system, do not use fluids other than the recommended ones nor mix different fluids for topping up.

Do not use clutch fluid taken from old or already opened containers.

Sudden variations in clearance or an elastic resistance in the clutch levers may be due to trouble in the hydraulic circuits.

Check that the clutch hoses are not twisted or worn. Prevent water or dust from accidentally getting into the circuit.

In case maintenance operations are to be performed on the hydraulic circuit, it is advisable to use latex gloves.

1.2.7 CARBON MONOXIDE

If it is necessary to let the engine run in order to carry out some work, make sure that the area in which you are operating is properly ventilated. Never run the engine in enclosed spaces. If it is necessary to work indoors, use an exhaust evacuation system.

⚠ WARNING

The exhaust fumes contain carbon monoxide, a poisonous gas that can cause loss of consciousness and even death.

Run the engine in an open area or, if it is necessary to work indoors, use an exhaust evacuation system.

1.2.8 HOT COMPONENTS

⚠ WARNING

The engine and the components of the exhaust system become very hot and remain hot for some time after the engine has been stopped.

Before handling these components, wear insulating gloves or wait until the engine and the exhaust system have cooled down.

1.3 RUNNING-IN RULES

The running-in of the engine is essential to ensure its duration and correct functioning.

If possible, drive on hilly roads and/or roads with many bends, so that the engine, the suspensions and the brakes undergo a more effective running-in.

During running-in, change speed.

In this way the components are first "loaded" and then "relieved" and the engine parts can thus cool down.

Even if it is important to stress the engine components during running-in, take care not to exceed.

⚠ CAUTION

Only after the first 1500 km (937 mi) of running-in is it possible to obtain the best performance.

Keep to the following indications:

- ◆ Do not open the throttle completely if the speed is low, both during and after the running-in.
- ◆ During the first 100 km (62 mi) put on the brakes with caution, avoiding sharp and prolonged brakings. This ensures a correct bedding-in of the pads on the brake disc.
- ◆ During the first 1000 km (625 mi) never exceed 6000 rpm. (see table).

⚠ CAUTION

After the first 1000 km (625 mi) perform the checking operations indicated in the "after running-in" column, see 2.1.1 (REGULAR SERVICE INTERVALS CHART) in order to avoid injuring yourself or others a/o damaging the vehicle.

- ◆ Between the first 1000 km (625 mi) and 1500 km (937 mi) drive more briskly, change speed and use the maximum acceleration only for a few seconds, in order to ensure better coupling of the components; never exceed 7500 rpm (see table).
- ◆ After the first 1500 km (937 mi) you can expect better performance from the engine, however, without exceeding the maximum allowed (10500 rpm).

Engine maximum rpm recommended	
Mileage km (mi)	rpm
0 – 1000 (0 – 625)	6000
1000 – 1500 (625 – 937)	7500
over 1500 (937)	10500

1.4 SPARE PARTS

For any replacement, use **aprilia** Genuine Spare Parts only, see 0.4.2 (SPARE PARTS CATALOGUES).

aprilia Genuine Spare Parts are high-quality parts, expressly designed and manufactured for **aprilia** vehicles.

⚠ CAUTION

Failure to use **aprilia Genuine Spare Parts may result in incorrect performance and damages.**

1.5 TECHNICAL SPECIFICATIONS

DIMENSIONS	
Max. length	2080 mm
RSV 01 Max. length	2070 mm
Max. length (with number plate-holder extension) OPT	2140 mm
Max. width	720 mm
RSV 01 Max. width	725 mm
Max. height (front part of the fairing included)	1170 mm
Seat height	820 mm
Distance between centres	1415 mm
Min. ground clearance	130 mm
Weight ready for starting (fuel and fluid included)	221 kg

ENGINE	
Model	V990
Type	60° longitudinal V-type, two-cylinder, 4-stroke, with 4 valves per cylinder, DOHC.
Number of cylinders	2
Total displacement	997.62 cm ³
Max. rated power (to driving shaft)	86.5 kW at 9250 rpm
RSV 01 Max. rated power (to driving shaft)	92 kW at 9250 rpm
Bore/stroke	97 mm/67.5 mm
Compression ratio	11.8 ± 0.4 : 1
Average piston speed	22.5 m/s at 10000 rpm
Camshaft during intake stroke	259°, valve lifting= 10.6 mm
RSV 01 Camshaft during intake stroke	262°, valve lifting= 11.4 mm
Camshaft during exhaust stroke	259°, valve lifting= 10.6 mm
Valve advance (with valve clearance 1mm) opening during intake stroke	20° before TDC
stroke closing during intake	59° after BDC
stroke opening during exhaust	64° before TDC
stroke closing during exhaust	15° after BDC
RSV 01 Valve advance (with valve clearance 1mm) opening during intake stroke	25° before TDC
stroke closing during intake	58° after BDC
stroke opening during exhaust	64° before TDC
stroke closing during exhaust	15° after BDC
Valve clearance during intake stroke	0.12 – 0.17 mm
Valve clearance during exhaust stroke	0.23 – 0.28 mm
Diameter of the inlet valve plate	36.0 mm
Diameter of the exhaust valve plate	31.0 mm
# Engine revolutions at minimum rpm	1250 ± 100 rpm
# Engine revolutions at peak rpm	10250 ± 100 rpm
Ignition	electronically controlled
Starting	electric
Spark advance	Variable according to speed and load
Starter motor gear ratio	$i = 49/9 * 30/11 * 64/30 = 31.677$
Clutch	multidisc in oil bath, with hydraulic control on the left side of the handlebar and PPC device - # 9 lined discs; thick 3.5 mm - # 9 internal discs; thick 1.5 mm

Follow ►

ENGINE	
Transmission	Mechanical, 6 gears with foot control on the left side of the engine
Lubrication system	dry pan with separate oil tank, # 2 trochoidal pumps and cooling radiator
Lubrication pressure	min 500 kPa (5 bar) at max 80 °C (176 °F) and 6000 rpm
Air cleaner	with dry filter cartridge
Cooling	liquid-cooled
Coolant pump gear ratio	$i_{wp} = 28/27 * 28/28 = 1.037$
Coolant pump delivery (with thermal expansion valve open)	90 ℓ/min and 9000 rpm
Thermal expansion valve opening start temperature	75 ± 2 °C (149 ± 5 °F)
Engine dry weight	~ 65 kg

CAPACITY	
Fuel (reserve included)	20 ℓ
RSV 01 Fuel (reserve included)	18 ℓ
Fuel reserve	4.5 ± 1 ℓ
Engine oil	oil change 3700 cm ³ oil and oil filter change 3900 cm ³
Fork oil (per rod)	520 ± 2.5 cm ³
Coolant	2.5 ℓ (50% water + 50% antifreeze with ethylene glycol)
Seats	2
Vehicle max. load (driver + passenger + luggage)	182 kg
RSV 01 Vehicle max. load (driver + passenger + luggage)	180 kg

DRIVE					
GEAR RATIOS	Ratio	Primary	Secondary	Final ratio	Total ratio
	1 ^a	31/60 = 1: 1.935	14/35 = 1: 2.500	17/42 = 1: 2.470	11.948
	2 ^a		16/28 = 1: 1.750		8.368
	3 ^a		19/26 = 1: 1.368		6.543
	4 ^a		22/24 = 1: 1.090		5.216
	5 ^a		23/22 = 1: 0.956		4.573
	6 ^a		27/23 = 1: 0.851		4.073
# sprocket teeth			17		
Drive chain			Endless type (with no connection link) with sealed links, model 525, dimensions 5/8" x 5/16"		

FUEL SUPPLY SYSTEM	
Type	electronic injection
Choke	Ø 51 mm

FUEL SUPPLY	
Type	indirect injection (MULTIPOINT)
Fuel	premium grade unleaded petrol, min. O.N. 95 (N.O.R.M.) and 85 (N.O.M.M.).

FRAME	
Type	two-beam frame with light alloy cast elements and extruded elements
Steering inclination angle	25°
Fore stroke	97 mm
RSV 01 Fore stroke	99 mm (with front tyre 120/70)

Follow ►

Follow ►



SUSPENSIONS	
Front	UPSIDE-DOWN telescopic adjustable fork with hydraulic operation, rod Ø 43 mm
Stroke	127 mm
Rear	oscillating rear fork in light alloy with differentiated profile arms and hydropneumatic adjustable mono-shock absorber
Wheel stroke	135 mm
BRAKES	
Front	with double floating disc – Ø 320 mm, calipers with four pins
Rear	disc brake – Ø 220 mm, caliper with double pin
WHEEL RIMS	
Type	in light alloy with withdrawable pin
Front	3.50 x 17"
Rear	6.00 x 17"
SPARK PLUGS	
Standard	NGK R DCPR9E
Spark plug gap	0.6 – 0.7 mm
Resistance	5 kΩ
ELECTRIC SYSTEM	
Battery	12 V – 12 Ah
Main fuses	30 A
Secondary fuses	15 A
Generator (with permanent magnet)	12 V – 400 W
Starter	12 V/0.9 kW
BULBS	
Low beam (halogen)	12 V – 55/55 W H4
RSV01 Low beam (halogen)	12 V – 55 W H7U
High beam (halogen)	12 V – 60 W H3
RSV01 High beam (halogen)	12 V – 55 W H7U
Front parking light	12 V – 5 W
Direction indicators	12 V – 10 W
Rear parking lights/Number plate light/Stoplight	12 V – 5/21 W
Revolution counter	12 V – 2 W
Right multifunction display	12 V – 2 W
WARNING LIGHTS	
Neutral	12 V – 3 W
Direction indicators	12 V – 3 W
Fuel reserve	12 V – 3 W
High beam	12 V – 2 W
Stand down	12 V – 3 W
Engine oil pressure	LED
Red line	LED

Follow ►

Follow ►





TYRES										
* = series RSV R . ** = series RSV .										
Wheel	Make	Model	Type	Size	Recommended		Alter- native	Pressure kPa (bar)		
					Road	Track		Normal use		Track
								Solo rider	Rider and pas- senger	
Front	PIRELLI	DRAGON EVO	MTR21 CORSA	120/70-ZR 17"	X	–	RSV	230 (2.3)	250 (2.5)	–
Rear	PIRELLI	DRAGON EVO	MTR22 CORSA	180/55-ZR 17"	X	–	RSV	250 (2.5)	280 (2.8)	–
Rear	PIRELLI	DRAGON EVO	MTR22 CORSA	190/50-ZR 17"	X	–	RSV	250 (2.5)	280 (2.8)	–
* Front	PIRELLI	DRAGON SUPERCORSA	–	120/70-ZR 17"	X	X	RSV RSV R	230 (2.3)	250 (2.5)	210 (2.1)
* Rear	PIRELLI	DRAGON SUPERCORSA	–	180/55-ZR 17"	X	X	RSV RSV R	250 (2.5)	280 (2.8)	200 (2.0)
** Front	METZELER	SPORTTEC	M1	120/70-ZR 17"	X	X	RSV RSV R	230 (2.3)	250 (2.5)	210 (2.1)
Rear	METZELER	SPORTTEC	M1	180/55-ZR 17"	X	X	RSV RSV R	250 (2.5)	280 (2.8)	200 (2.0)
** Rear	METZELER	SPORTTEC	M1	190/50-ZR 17"	X	X	RSV RSV R	250 (2.5)	280 (2.8)	200 (2.0)
Front	METZELER	RENNSPORT	–	120/70-ZR 17"	X	X	RSV RSV R	230 (2.3)	250 (2.5)	210 (2.1)
Rear	METZELER	RENNSPORT	–	180/55-ZR 17"	X	X	RSV RSV R	250 (2.5)	280 (2.8)	200 (2.0)
** Front	MICHELIN	PILOT SPORT	E	120/70-ZR 17" TL	X	–	RSV	230 (2.3)	250 (2.5)	–
** Rear	MICHELIN	PILOT SPORT	E	190/50-ZR 17" TL	X	–	RSV	250 (2.5)	280 (2.8)	–
Front	MICHELIN	SPORTCUP	–	120/70-ZR 17"	X	X	RSV R	230 (2.3)	250 (2.5)	210 (2.1)
Rear	MICHELIN	SPORTCUP	–	180/55-ZR 17"	X	X	RSV R	250 (2.5)	280 (2.8)	190 (1.9)
Front	MICHELIN	PILOT RACE	H	120/70-ZR 17"	–	X	RSV R	–	–	210 (2.1)
Rear	MICHELIN	PILOT RACE	H	180/55-ZR 17"	–	X	RSV R	–	–	190 (1.9)
Front	BRIDGE- STONE	BT 010	–	120/70-ZR 17"	X	–	RSV	230 (2.3)	250 (2.5)	–
Rear	BRIDGE- STONE	BT 010	–	180/55-ZR 17"	X	–	RSV	250 (2.5)	280 (2.8)	–
Rear	BRIDGE- STONE	BT 010	–	190/50-ZR 17"	X	–	RSV	250 (2.5)	280 (2.8)	–
** Front	DUNLOP	SPORTMAX	D 207 F RR	120/70-ZR 17"	X	X	RSV RSV R	230 (2.3)	250 (2.5)	210 (2.1)
** Rear	DUNLOP	SPORTMAX	D 207 RR	190/50-ZR 17"	X	–	RSV	250 (2.5)	280 (2.8)	–
Rear	DUNLOP	SPORTMAX	D 207 RR	180/55-ZR 17"	X	X	RSV	250 (2.5)	280 (2.8)	190 (1.9)





1.6 LUBRICANT CHART**1.6.1 LUBRICANT CHART (for models up to 2001)**





Engine oil (recommended):  EXTRA RAID 4, SAE 15W - 50 or  TEC 4T SAE 15W - 50.



As an alternative to the recommended oil, it is possible to use high-quality oils with characteristics in compliance with or superior to the CCMC G-4, A.P.I. SG specifications.

Fork oil (recommended):  F.A. 5W or  F.A. 20 W fork oil;
an alternative  FORK 5W or  FORK 20W fork oil.

If you need an oil with intermediate characteristics in comparison with the  F.A. 5W and  F.A. 20 W or  FORK 5W and  FORK 20W, these can be mixed as indicated below:

SAE 10W =  F.A. 5W 67% of the volume, +  F.A. 20W 33% of the volume or
 FORK 5W 67% of the volume +  FORK 20W 33% of the volume.

SAE 15W =  F.A. 5W 33% of the volume, +  F.A. 20W 67% of the volume or
 FORK 5W 33% of the volume +  FORK 20W 67% of the volume.

Bearings and other lubrication points (recommended):  Bimol Grease 481,  AUTOGREASE MP or  GREASE 30.

As an alternative to the recommended product, use high-quality grease for rolling bearings, working temperature range -30 °C...+140 °C, dripping point 150 °C...230 °C, high protection against corrosion, good resistance to water and oxidation.

Protection of the battery poles: neutral grease or vaseline.

Spray grease for chains (recommended):  CHAIN SPRAY or  CHAIN LUBE.

⚠ WARNING

Use new brake fluid only.

Brake fluid (recommended):  F.F., DOT 5 (DOT 4 compatible) or  BRAKE 5.1, DOT 5 (DOT 4 compatible).

⚠ WARNING

Use new clutch fluid only.

Clutch fluid (recommended):  F.F., DOT 5 (DOT 4 compatible) or  BRAKE 5.1, DOT 5 (DOT 4 compatible).



⚠ WARNING

Use only antifreeze and anticorrosive without nitrite, ensuring protection at -35 °C at least.





Engine coolant (recommended):  ECOBLU -40 °C or  COOL.





OILL-UK





1.6.2 LUBRICANT CHART **RSV 01**





Engine oil (recommended):  EXTRA RAID 4, SAE 15W - 50 or  TEC 4T, SAE 15W - 50.

As an alternative to the recommended oil, it is possible to use high-quality oils with characteristics in compliance with or superior to the CCMC G-4, A.P.I. SG. specifications.



RSV Fork oil (recommended):  F.A. 5W or  F.A. 20W; as an alternative  FORK 5W or  FORK 20W.

If you need an oil with intermediate characteristics in comparison with the  F.A. 5W and  F.A. 20W or  FORK 5W and  FORK 20W, these can be mixed as indicated below:

SAE 10W =  F.A. 5W 67% of the volume, +  F.A. 20W 33% of the volume or
 FORK 5W 67% of the volume +  FORK 20W 33% of the volume.

SAE 15W =  F.A. 5W 33% of the volume, +  F.A. 20W 67% of the volume or
 FORK 5W 33% of the volume +  FORK 20W 67% of the volume.

“R” **RSV R** (**RSV OPT**) fork oil: OHLINS 10W.

Bearings and other lubrication points (recommended):  Bimol Grease 481,  AUTOGREASE MP or  GREASE 30.

As an alternative to the recommended product, use high-quality grease for rolling bearings, working temperature range -30°C... +140°C, dripping point 150°C... 230°C, high protection against corrosion, good resistance to water and oxidation.

Protection of the battery poles: neutral grease or vaseline.

Spray grease for chains (recommended):  CHAIN SPRAY or  CHAIN LUBE.



⚠ WARNING

Use new brake fluid only.

Brake fluid (recommended):  F.F., DOT 5 (DOT 4 compatible) or  BRAKE 5.1, DOT 5 (compatible DOT 4).

⚠ WARNING

Use new clutch fluid only.

Clutch fluid (recommended):  F.F., DOT 5 (compatible with DOT 4) or  BRAKE 5.1, DOT 5 (compatible DOT 4).

⚠ WARNING

Use only antifreeze and anticorrosive without nitrite, ensuring protection at -35°C at least.

Engine coolant (recommended):  ECOBLU -40°C or  COOL.

OILN-ING

1.7 SPECIAL TOOLS OPT

In order to perform assembly, reassembly and settings correctly, special tools suitable for the task must be used. The use of special tools avoids the potential risk of damage as a result of inappropriate tools and/or improvised methods.

Below is a list of the special tools designed especially for this specific vehicle.

If necessary, request the multi-purpose special tools, see 0.4.3 (SPECIAL TOOL MANUALS).

⚠ CAUTION

Before using the special tools, consult any documents attached.

1.7.1 SUPPORT STANDS

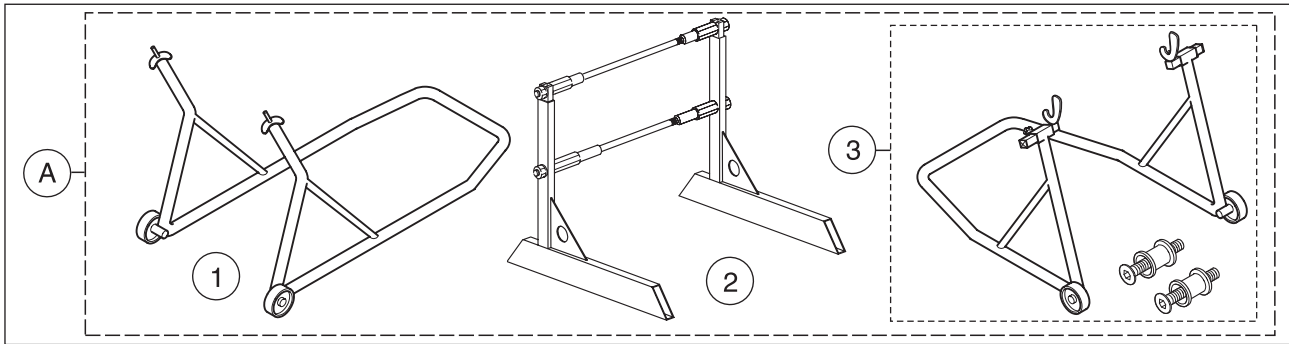

Pos.	aprilia part# (tool description and function)
A	8140176 (complete support stand kit)
1	8146486 (front support stand)
2	xxxxxxx N.A. [centre stand]
3	8705021 (rear support stand)

xxxxxxx N.A. = available only with the aprilia kit part# 8140176 (complete support stand kit)

1.7.2 FRAME TOOLS

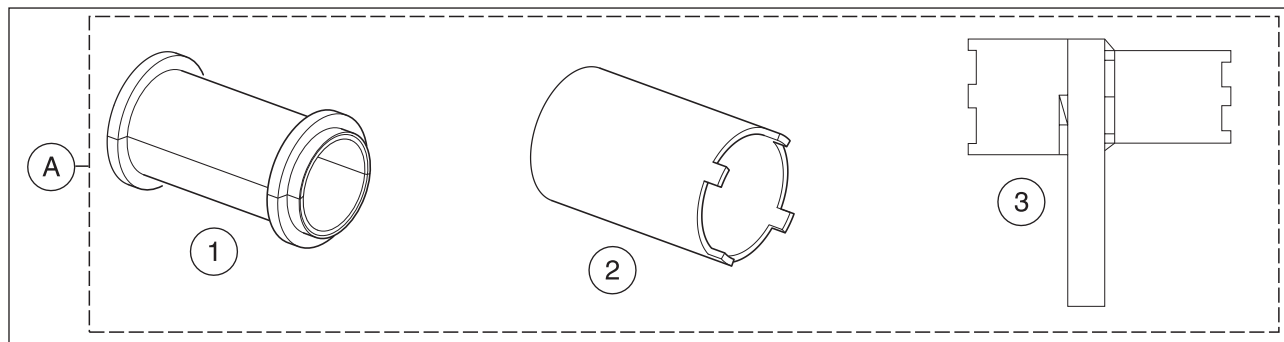

Pos.	aprilia part# (tool description and function)
A	8140203 (complete tool kit for frame including)
1	8140189 [oil seal fitting tool - Ø 43 hole. Kit accessory aprilia part# 8140151 (complete tool kit for fork including)]
2	8140190 (steering tightening tool)
3	8140191 (rear fork pin and engine support tightening tool)

1.7.3 FORK TOOLS

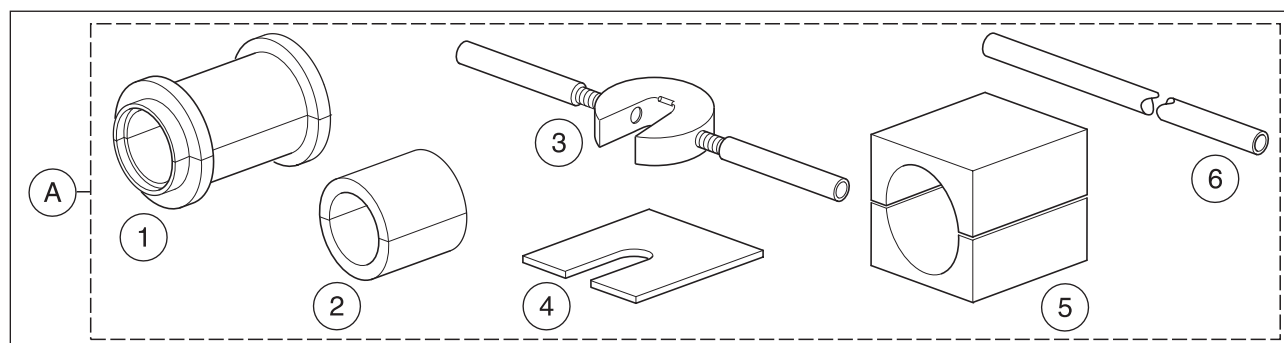

Pos.	aprilia part# (tool description and function)
A	8140151 (complete tool kit for fork including)
1	8140145 (Ø 41 mm sealing ring fitting tool)
2	8140146 [weight to be applied to the tool: aprilia part# 8140145 (Ø 41 mm sealing ring fitting tool)] e aprilia part# 8140189 [oil seal fitting tool - Ø 43 hole. Kit accessory aprilia part# 8140151 (complete tool kit for fork including)]
3	8140147 (spacer holding tool)
4	8140148 (spacer/pumping element separating plate)
5	8140149 (protection element for disassembly operations)
6	8140150 (drilled rod for pumping element bleeding)

1.7.4 ENGINE TOOLS

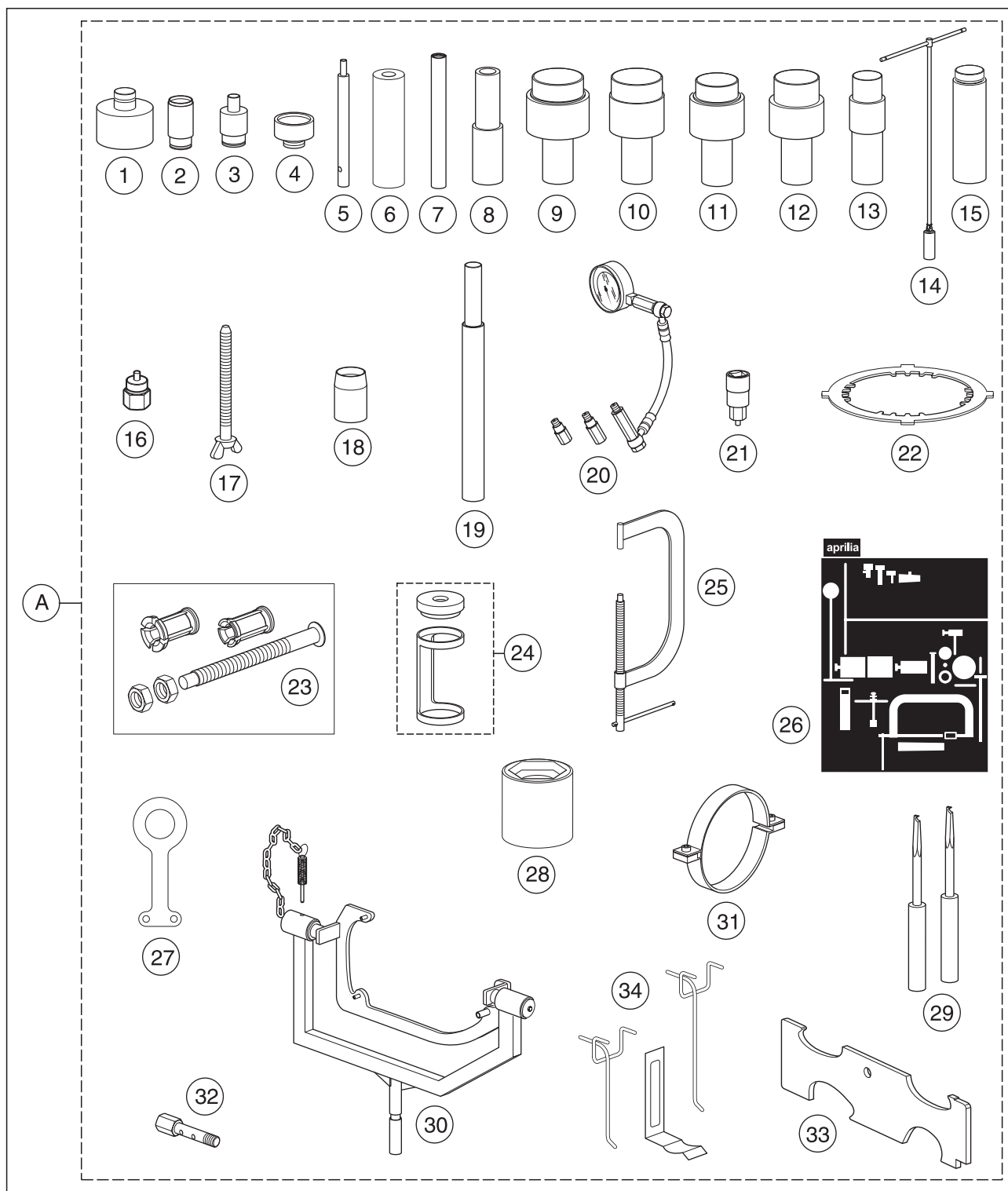

Pos.	aprilia part# (tool description and function)
A	8140175 (complete tool kit for engine including)
1	0277680 (gearshift secondary shaft oil seal assembly pad)
2	0277660 (upper countershaft oil seal assembly pad)
3	0277670 (coolant pump shaft housing oil seal assembly pad)
4	0877257 (assembly pad for water pump shaft seat sliding ring)
5	0277510 (valve guide disassembly pad)
6	0277210 (valve guide assembly)
7	0277695 (valve guide oil seal assembly pad)
8	8140155 (gearshift shaft oil seal - clutch shaft oil seal assembly pad)
9	0277725 (driving shaft bush inserter pad)
10	0277720 (driving shaft sleeve puller** pad)
11	0277537 (lower countershaft bush inserter pad)
12	0277727 (driving shaft - clutch cover bush inserter pad)
13	0277729 (insertion pad for lower balance shaft clutch cover bushes)
14	8140177 (plug socket spanner)
15	0277252 (flywheel magneto cover removal tool)
16	0277730 (flywheel removal hexagonal bolt)
17	0240880 (threaded bolt to lock the drive shaft at the TDC)
18	0277308 (gearshift secondary shaft guide bush)
19	8140178 (pin installation and removal pad)
20	8140181 (fuel-oil pressure gauge-compression)
21	8140182 (rotor bolt bush)
22	0277881 (clutch blocking tool)
23	8140156 + 8140157 + 0276377 (clutch cover sleeve puller)
24	0276479 (valve spring compression tool)
25	8140179 (valves disassembly and reassembly bow)
26	8157143 (adhesive for tool holder panel RSVmille)
27	8140183 (engine lifting eye hook)
28	8140184 (primary transmission nut disassembly bush)
29	8140185 (clutch disc** extraction hook lever)
30	8140188 (engine support)
31	8140186 (piston ring compression tool)
32	8140197 (perforated bolt for fuel pressure test fuel)
33	8140205 (camshaft template)
34	8140426 (panel hooks)

1.7.5 MISCELLANEOUS TOOLS

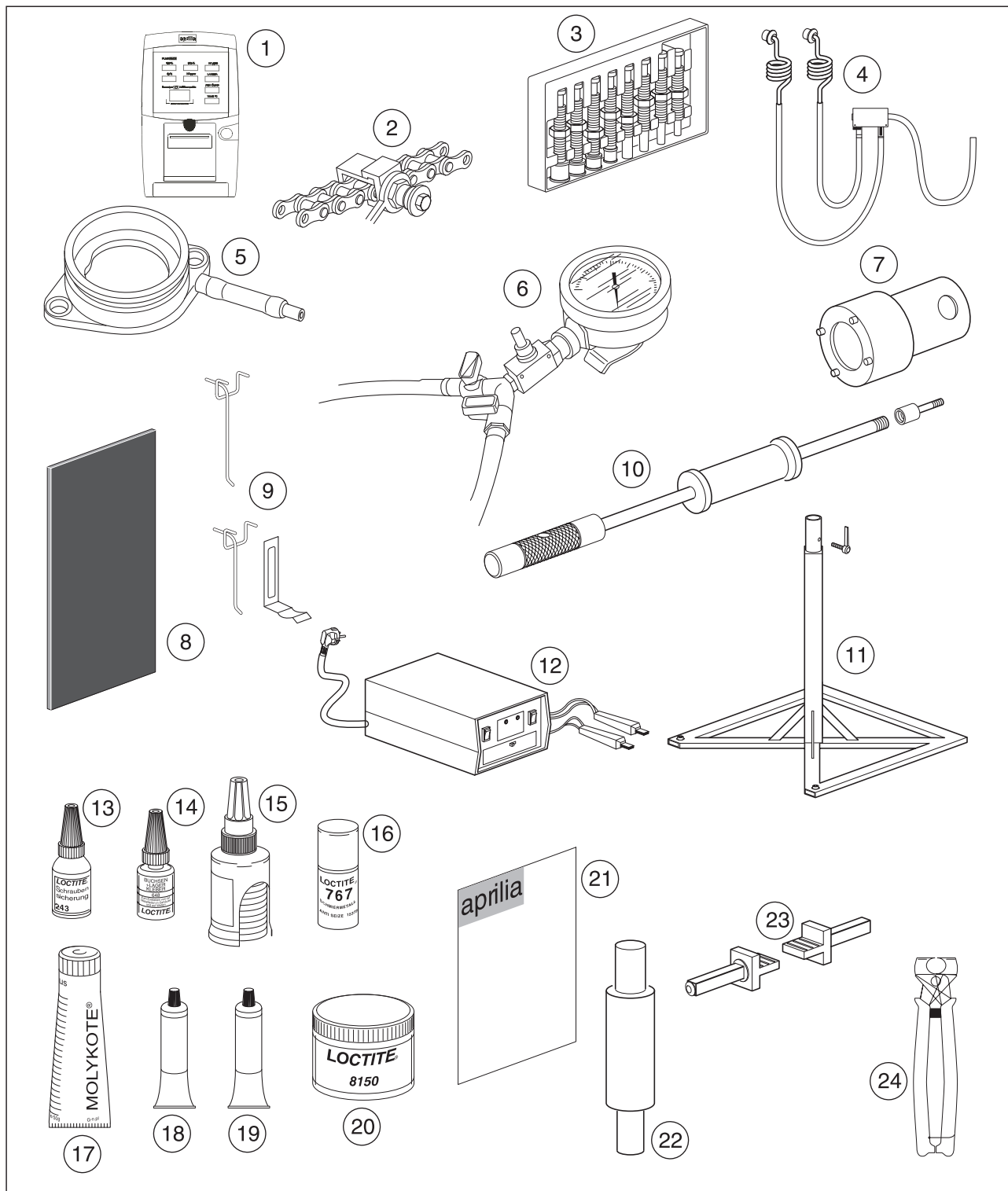

Pos.	aprilia part# (tool description and function)
1	8140196 [Plurigas (Italian)]
1	8140578 [Plurigas (English)]
2	8140192 (chain installation kit)
3	8140180 (bearing extractors)
4	8140202 (exhaust gas analysis probes)
5	8140267 (intake flange for vacuumeter)
6	8140256 (vacuometer)
7	8140424 (OHLINS fork spanner)
8	8140199 (tool panel)
9	8140426 (panel hooks)
10	8140432 (pushing extractor)
11	8140187 (engine support stand)
12	8124838 (battery charger M.F.)
13	0897651 [LOCTITE® 243 blue (10 cm ³)]
14	0899788 [LOCTITE® 648 green (5 g)]
15	0899784 (LOCTITE® 574 orange)
16	0297434 (LOCTITE® 767 Anti-Seize 15378)
17	0297433 [MOLYKOTE® G-N (50 g)]
18	0897330 (multi-purpose grease bp lz)
19	0297386 [SILASTIC 732 RTV (100 g)]
20	8116067 (LOCTITE® 8150)
21	8202222 (panel adhesive sheet)
22	8140074 (lower countershaft bush inserter pad)
23	8140204 (rear stand supports)
24	0277295 (hose clamp installation pliers)

1.7.6 TOOLS USED FOR OTHER **aprilia** VEHICLES

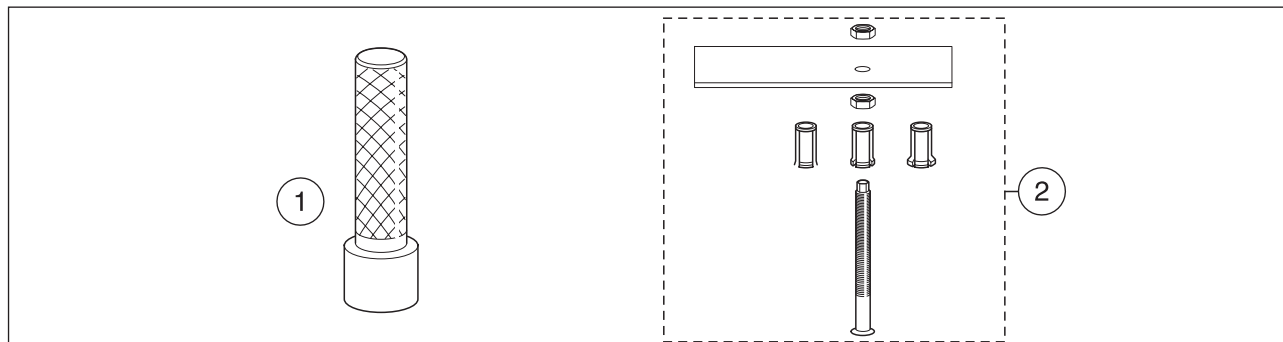

Pos.	aprilia part# (tool description and function)
1	0877650 (handle for pads)
2	0277265 (extractor for balance shaft, gearbox input and output shaft)
-	8116050 (engine oil)
-	8116053 (grease  Bimol Grease 481)
-	8116038 (grease LUBERING ST)
-	xxxxxxx N.A. (AP-LUBE temporary lubricant)
-	xxxxxxx N.A. (grease DID CHAIN LUBE)
-	8116031 (Fluid "Biosolvent" frame detergent)
-	8116945 ("ACRILON 28" cyanoacrylic glue)
-	xxxxxxx N.A. (MOTUL MOTOWASH degreaser)
-	8116043 (ANTI-SEIZE MOTAGEPASTE AS 1800 antiscuff paste)
-	xxxxxxx N.A. (alcohol)
-	0898011 (fluorescent green LOCTITE® 275)
-	xxxxxxx N.A. (LOCTITE® 572)

xxxxxxx N.A. = not available

1.8 POSITIONING THE VEHICLE ON THE SUPPORT STAND

1.8.1 ASSEMBLING THE PINS FOR THE REAR SUPPORT STAND **OPT**

NOTE Have the appropriate special tool **OPT** to hand:

- **aprilia** part# xxxxxxx N.A. [centre stand].
- ◆ Position the vehicle on the side stand on firm and level ground.
- ◆ ★ Position the pin (1) on the appropriate seat on the rear fork.
- ◆ ★ Screw and tighten the screw (2) in the appropriate threaded hole in the rear fork.

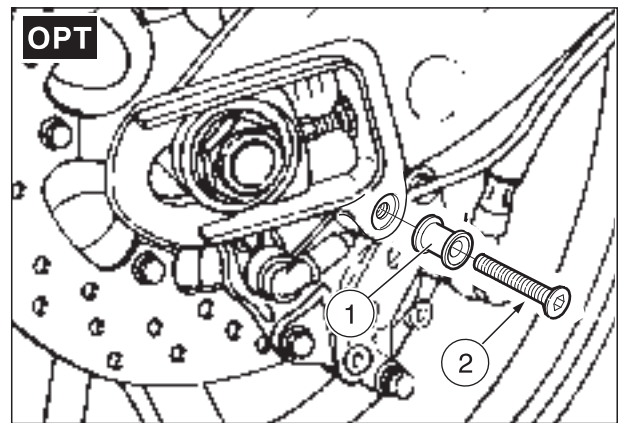

1.8.2 POSITIONING THE VEHICLE ON THE REAR SUPPORT STAND **OPT**

NOTE Have the appropriate special tool **OPT** to hand:

- **aprilia** part# xxxxxxx N.A. [centre stand].
- ◆ Fit the relevant pins, see 1.8.1 (ASSEMBLING THE PINS FOR THE REAR SUPPORT STAND **OPT**).

NOTE Have someone help you keep the vehicle in vertical position with the two wheels on the ground.

- ◆ ★ Loosen the knob (3).
- ◆ ★ Move the fork support (4), positioning it so that the width corresponds to the distance between the two pins (1) on the rear fork.
- ◆ ★ Tighten the knob (3).
- ◆ At the same time introduce the two fork-shaped seats (4) of the stand (5) under the two pins (1) provided on the vehicle.

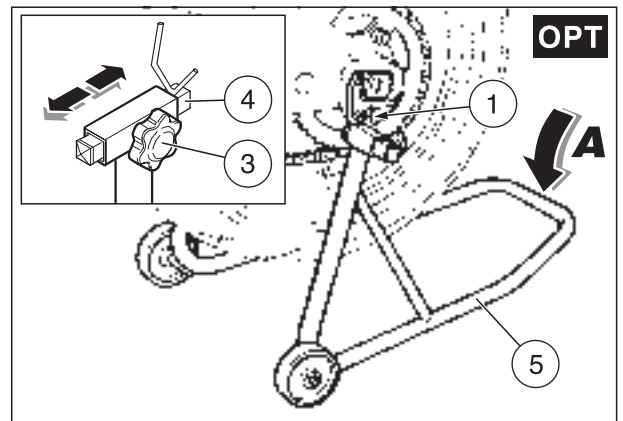

⚠ CAUTION

Grasping the stand in another way than indicated in the figure may cause your fingers to be crushed between the stand and the ground.

- ◆ Grasp the terminal central part of the stand (5) with your hands (**Pos.A**).
- ◆ Push the stand (5) downwards until it reaches the end of its stroke.

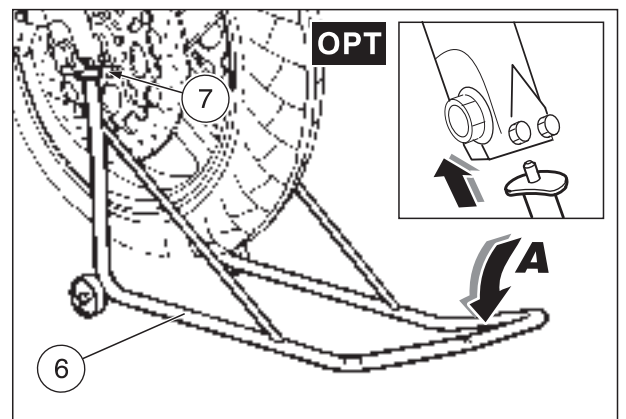

1.8.3 POSITIONING THE VEHICLE ON THE FRONT SUPPORT STAND **OPT**

NOTE Have the appropriate special tool **OPT** to hand:

- **aprilia** part# 8146486 (front support stand).
- ◆ Position the vehicle on the appropriate rear support stand, see 1.8.2 (POSITIONING THE VEHICLE ON THE REAR SUPPORT STAND **OPT**).
- ◆ Insert the two ends of the stand (6) in the two holes (7) positioned on the lower ends of the front fork.

⚠ CAUTION

Grasping the stand in another way than indicated in the figure may cause your fingers to be crushed between the stand and the ground.

- ◆ Grasp the terminal central part of the stand (6) with your hands (**Pos.A**).
- ◆ Push the stand (6) downwards until it reaches the end of its stroke.

1.8.4 POSITIONING THE VEHICLE ON THE CENTRE SUPPORT STAND OPT

Carefully read 0.5.1 (PRECAUTIONS AND GENERAL INFORMATIONS).

- NOTE** Have the appropriate special tool OPT to hand:
- **aprilia** part# 8146486 (front support stand).
 - ◆ Set the vehicle on the relevant front support stand, see 1.8.3 (POSITIONING THE VEHICLE ON THE FRONT SUPPORT STAND OPT).
 - ◆ ★Hold the nut on the inside (1) still.

Driving torque of the engine-frame rear fastening screw: 50 Nm (5.0 kgm).

- ◆ ★Unscrew and remove the engine upper rear fastening screw (2).

NOTE The screw (2) on the left-hand side is longer.

- ◆ ★Retrieve the nut (1).
- ◆ Insert the upper right support pin (3) in the upper hole on the right-hand side.
- ◆ Insert the stud bolt (4) in the upper hole on the left-hand side and screw it all the way onto the pin (3).
- ◆ Screw the upper left support pin (5) all the way onto the stud bolt (4) and tighten.
- ◆ ★Hold the nut on the inside (6) still.

Driving torque of the engine-frame lower fastening screw: 50 Nm (5.0 kgm).

- ◆ ★Unscrew and remove the engine lower rear fastening screw (7).

NOTE The screw (7) on the right-hand side is longer.

- ◆ Insert the lower right support pin (8) in the lower hole on the right-hand side.
- ◆ Insert the stud bolt (9) in the lower hole on the left-hand side and screw it all the way onto the pin (8).
- ◆ Screw the lower left support pin (10) all the way onto the stud bolt (9) and tighten.
- ◆ Place the support bracket (11) with the longer side of the base facing forwards, on the two support pins (3 - 8).
- ◆ Insert the two washers (12) (13) and two nuts (14) (15), screwing them on by hand.
- ◆ Tighten the two nuts (14) (15).
- ◆ Place the support bracket (16) with the longer side of the base facing forwards, on the two support pins (5) (10).
- ◆ Insert the two washers (17) (18) and two nuts (19) (20), screwing them on by hand.
- ◆ Tighten the two nuts (19) (20).
- ◆ Remove the front and rear support stands.

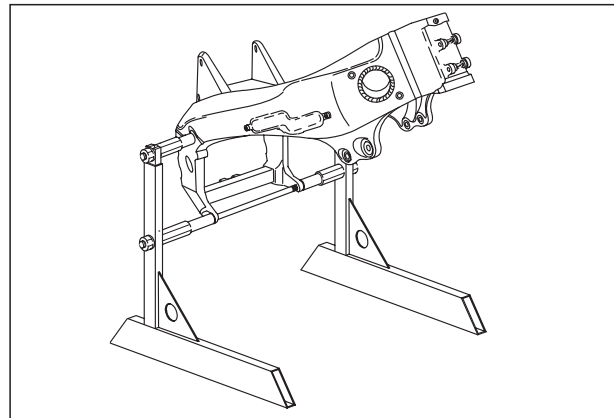
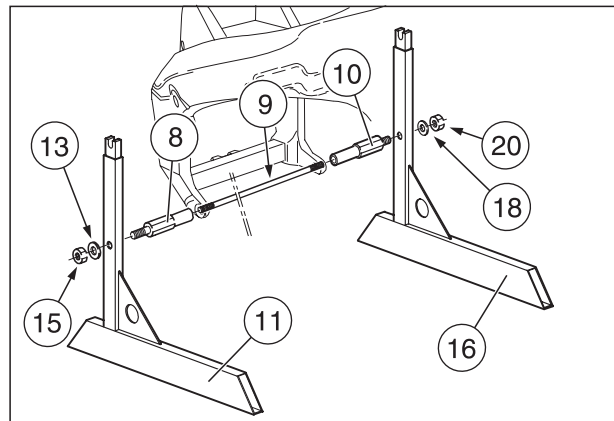
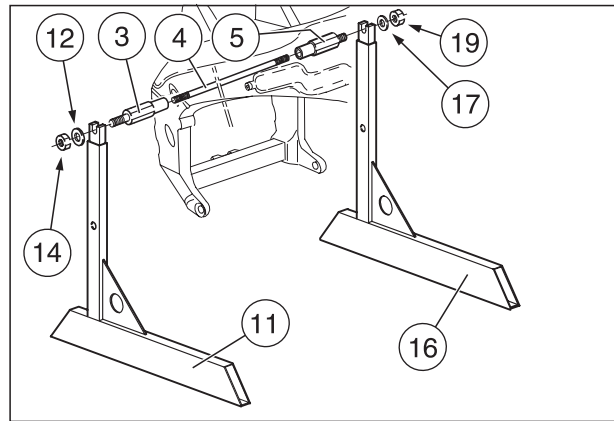
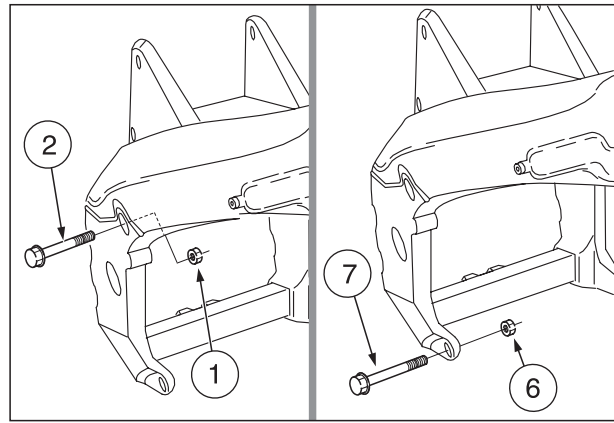









1.9 CONSUMABLES

Only use the products given below for any maintenance work.

The materials mentioned have been tested for many years and are suitable for all the application conditions indicated by the manufacturer.

NOTE The consumables, which are coded, are available on application, see 1.9.2 (USE OF CONSUMABLES).

1.9.1 PRODUCT PROPERTIES

aprilia part# (product)	Use and properties
<p>aprilia part# 0897651 [LOCTITE® 243 blue (10 cm³)]</p> 	<p>Adhesive in paste for screws and nuts up to M36 and for couplings with medium hold. It can be used on parts which have not been completely degreased. The hardening time depends on the temperature and the material (maximum one hour). Resistance to temperatures in the range – 55 to 150 °C (– 99 to 302 °F).</p>
<p>aprilia part# 0898011 (fluorescent green LOCTITE® 275) (**)</p> 	<p>It prevents the loosening of the threaded components and the fluid leakages due to vibrations. It must be used on clean, degreased and non-oxidized components. Apply a quantity sufficient to cover all the threaded part.</p>
<p>aprilia part# 0899788 [LOCTITE® 648 green (5 g)]</p> 	<p>Paste for strong fastening of screws. The hardening time depends on the temperature and the material (maximum twelve hours). Resistance to temperatures in the range -55 to 175 °C (– 99 to 347 °F). In order to release the part glued, it may be necessary to heat the coupled parts to a temperature of 250 °C (482 °F).</p>
<p>aprilia part# 0899784 (LOCTITE® 574 orange)</p> 	<p>Solvent-free seal in paste, to be used instead of seals where there is a high friction factor and where a precise distance is required between the two components. Applied in its liquid state, it hardens after assembly on contact with the metal within a few hours. A seal is created whose surface structure adapts to the surfaces to be sealed. Resistance to temperatures in the range – 55 to 200 °C (– 99 to 392 °F); where applied, it seals the surfaces against corrosion.</p>
<p>aprilia part# 8116067 (LOCTITE® 8150)</p> 	<p>Paste to be used on components subjected to high temperature.</p>
<p>aprilia part# 0297434 (LOCTITE® 767 Anti-Seize 15378)</p> 	<p>Lubricant and anticorrosive resistant to high temperatures. It must be sprayed on both components and makes sure the sliding surfaces remain maintenance free for a long time. It prevents corrosion.</p>
<p>aprilia part# 0297433 [MOLYKOTE® G-N (50 g)]</p> 	<p>Lubricating paste to be used on support points subjected to heavy loads, for standard lubrication and on couplings under pressure, in order to prevent corrosion which would prevent subsequent disassembly. To apply on the two surfaces.</p>
<p>aprilia part# 0297386 [SILASTIC 732 RTV (100 g)]</p> 	<p>It is used as a sealant, preventing water from getting inside the flywheel cover.</p>

1.9.2 USE OF CONSUMABLES

For use descriptions that have been involuntarily omitted in this list and for any further information on the use of expendable materials, see 0.4.2 (SPARE PARTS CATALOGUES).

(*) = see 1.6 (LUBRICANT CHART).

(**) = see 1.9.1 (PRODUCT PROPERTIES).

xxxxxxx N.A. = not available

aprilia part# (product)	Description of use
<p>aprilia part# 8116050 (engine oil) (*)</p>	<ul style="list-style-type: none"> - Assembly of rivets on fork, dashboard/front fairing mount, saddle support and frame. - Assembly of frame/engine and frame/fork adjusting bushes. - Assembly of fairlead screws on frame. - Insertion of steering head bearings. - Steering head upper bush. - On timing intermediate gear roller bearings. - On lower countershaft thrust washer. - Clutch disengaging shaft. - On valve stems and valve lifter buckets. - On valve guide oil seals. - On camshaft housings. - On the timing chain tightener. - On double starter gear and idler gear pins. - On the freewheel gear/freewheel contact surface. - On the freewheel inner contact surface. - On the piston segment seats.
<p>aprilia part# 0897651 [LOCTITE® 243 blue (10 cm³)] (**)</p>	<ul style="list-style-type: none"> - Fastening of steering shock absorber bush. - Fastening of rear brake caliper lock pin. - Fastening of pinion. - Fastening of rear brake lever pin. - Fastening of cooling electrofan on support. - Fastening of fuel return pipe connection. - Fastening of fuel filler cap. - Throttle cable pullet fastening nut. - Throttle cable support bracket fastening screws. - Throttle valve pin fastening nut. - Throttle valve potentiometer fastening screws. - On coolant pump centre fastening screw. - On cylinder joining bracket fastening screws. - On engine half-casing bearing lock screws. - On the cylinder fastening stud bolts (engine crankcase half side). - On driving shaft position sensor fastening screws. - On the camshaft position sensor fastening screws. - On index lever and plate fastening screws. - On driving shaft fastening nut. - On timing gear fastening screws. - On upper countershaft counterweight fastening nut. - On intermediate timing gear bearing support lower fastening screw. - On the thread of the coolant duct plug on the rear cylinder. - On the thread of the engine oil pressure sensor. - On the thread of the stator fastening screws.
<p>aprilia part# 0898011 (fluorescent green LOCTITE® 275) (**)</p>	<ul style="list-style-type: none"> - On the thread of the cylinder coolant inlet and outlet pipes.
<p>aprilia part# xxxxxxx N.A. (LOCTITE® 572)</p>	<ul style="list-style-type: none"> - Fastening of coolant thermal switch. - Fastening of the coolant draining screws positioned on the radiators.

Follow ►

aprilia part# (product)	Description of use
aprilia part# 0899788 [LOCTITE® 648 green (5 g)] (**)	<ul style="list-style-type: none"> - On coolant pump idler gear pin. - On engine oil pump plug. - On the fastening screws of the clutch gear spring-holding plate. - Freewheel assembly on flywheel magneto. - On the freewheel/rotor flange fastening screws. - On clutch housing fastening nut. - On lower countershaft counterweight fastening screw. - On the freewheel housing fastening screws. - On flywheel rotor inner cone. - On flywheel fastening screw. - On the contact surface between the freewheel housing and the flywheel magneto. - On the thread of the stud bolts that fasten the exhaust pipes to the cylinders (cylinder side).
aprilia part# 8116043 (ANTI-SEIZE MOTAGE-PASTE AS 1800 antiscuff paste)	<ul style="list-style-type: none"> - Assembly of plugs for checking CO on exhaust pipes.
aprilia part# 0899784 (LOCTITE® 574 orange) (**)	<ul style="list-style-type: none"> - Fastening of coolant thermistors. - On neutral gear switch contact screw. - On the contact surface of the engine oil pump central body with the external body and with the crankcase. - On the cylinder's base where it rests on the engine casing. - On the thread of the 90° oil union on the rear cylinder.
aprilia part# 0297434 (LOCTITE® 767 Anti-Seize 15378) (**)	<ul style="list-style-type: none"> - On gearshift primary and secondary shaft. - On gearshift primary and secondary shaft housings. - On driving shaft and countershaft. - On the gearshift primary shaft housing and tothing.
aprilia part# 0297433 [MOLYKOTE® G-N (50 g)]	<ul style="list-style-type: none"> - On main bush housings. - On main bushes. - On engine casing bearing housings. - On coolant pump shaft. - On valve guide slots on the head. - On valve guide edges. - On the contact area with the cams of the valve caps. - On driving shaft and countershaft bush housings. - On driving shaft and countershaft housings. - On connecting rod/piston pin slots. - On camshaft cams. - On starter motor fastening housing.
aprilia part# 0297386 [SILASTIC 732 RTV (100 g)] (**)	<ul style="list-style-type: none"> - On cable bracket on flywheel cover. - On camshaft sensor cable. - On the camshaft sensor cable guide.
aprilia part# 8116053 (grease  Bimol Grease 481)	<ul style="list-style-type: none"> - Assembly of front and rear wheel seals. - Assembly of fork pin bearings. - Assembly of clutch pump control rod. - On rear wheel pin thread. - On steering head bearings. - Assembly of rear brake pump control rod. - On rear brake lever pin. - On intermediate timing gear thrust washer. - Upper countershaft oil seal. - Starter motor gear.
aprilia part# 8116038 (grease LUBERING ST)	<ul style="list-style-type: none"> - Assembly of cold-start control.

Follow ►

aprilvia part# (product)	Description of use
aprilvia part# xxxxxxx N.A. (AP-LUBE temporary lubricant)	<ul style="list-style-type: none"> - Assembly of handlebar counterweights rubber element. - Assembly of throttle cable adjuster rubber elements. - Assembly of rubber element on gearshift lever. - Insertion of radiator lower pins on supporting rubber elements. - Assembly of breather pipe on radiator and three-way manifold. - Assembly of coolant couplings on radiators. - Assembly of water and fuel drainage pipes on fuel pump flange. - Assembly of throttle body torsion springs.
aprilvia part# xxxxxxx N.A. (grease DID CHAIN LUBE)	<ul style="list-style-type: none"> - Lubrication of driving chain.
aprilvia part# 8116031 (Fluid "Biosolvent" frame detergent)	<ul style="list-style-type: none"> - Washing of engine oil tank.
aprilvia part# 8116945 ("ACRILON 28" cyanoacrylic glue)	<ul style="list-style-type: none"> - Assembly gasket air filter casing.
aprilvia part# xxxxxxx N.A. (MOTUL MOTOWASH degreaser)	<ul style="list-style-type: none"> - Cleaning of frame and fork.
aprilvia part# xxxxxxx N.A. (alcohol)	<ul style="list-style-type: none"> - Cleaning of left handlebar prior to assembly of grip. - Insertion of radiator breather pipes on "T" union. - Assembly of HV coil support rubber element. - Assembly of side fairing rubber elements. - Cleaning of lower part of engine. - Assembly of start relay rubber element. - Assembly of flexible couplings on rear wheel sprocket. - Assembly of rubber elements on engine oil radiator. - Assembly of coupling on coolant filler. - Cleaning of engine oil tank prior to application of transfers. - Assembly of dashboard/front fairing mount rubber elements. - Assembly of rubber element on rear brake lever. - Assembly of pipes on fuel filter (inside tank). - Assembly of coolant radiator union coupling. - Assembly of fuel pipes on tank. - Cleaning of fuel tank prior to application of transfers.

1.10 FASTENING ELEMENTS

1.10.1 JOINTS WITH HOSE CLAMPS AND SCREW CLAMPS

Carefully read 1.2 (INSTRUCTIONS FOR USE OF FUEL, LUBRICANTS, COOLANT AND OTHER COMPONENTS).

⚠ CAUTION

Remove **ONLY** the clamps indicated in the maintenance procedures.

This text is not to be intended as an authorization to arbitrarily remove the clamps present on the vehicle.

⚠ WARNING

Before removing a clamp, make sure that the removal does not involve any fluid leakage; if so, provide for preventing such leakages and protect the components positioned near the joint.

HOSE CLAMPS

For the removal it is sufficient to use simple pliers, while for the installation it is necessary to use a special tool (see below).

Before removing a clamp, prepare the material necessary for the correct reassembly.

NOTE Have the appropriate special tool **OPT** to hand:
– **aprilia** part# 0277295 (hose clamp installation pliers).

⚠ CAUTION

Upon installation, replace the hose clamp that has been removed with a new one having the same dimensions, see 0.4.2 (SPARE PARTS CATALOGUES).

Do not attempt to reinstall the removed hose clamp, since it is unusable.

Do not replace the removed hose clamp with a screw clamp or with other types of clamp.

⚠ CAUTION

Proceed with care, in order not to damage the joint components.

- ◆ Work with the pliers on the head of the hose clamp, forcing until you release it.

SCREW CLAMPS

For the removal and installation it is sufficient to use a simple screwdriver.

⚠ CAUTION

Check the conditions of the screw clamp and if necessary replace it with a new one of the same type and dimensions, see 0.4.2 (SPARE PARTS CATALOGUES).

When fastening the clamp, make sure that the joint is sufficiently stable.



1.10.2 GENERAL SPECIFICATIONS OF THE DRIVING TORQUES

The following table indicates the standard driving torques for screws and bolts with metric ISO thread.

Screw or bolt thread	Spanner	Driving torque	
		Nm	kgm
M6	10	6	0.6
M8	12	15	1.5
M10	14	30	3.0
M12	17	55	5.5
M14	19	85	8.5
M16	22	130	13.0

For specific joints or couplings of the vehicle, see 1.10.3 (DRIVING TORQUES).

If not specified otherwise, the indicated driving torques are valid for clean and dry threads, at room temperature.

NOTE In order to avoid any deformation and/or imperfect coupling, tighten the screws or bolts by proceeding as described below:

- ◆ Manually screw all the fastening elements.
- ◆ Applying half the prescribed driving torque, tighten the elements that are diametrically opposite each other: (A) and (B); (C) and (D).
- ◆ Repeat the previous operation by applying the prescribed driving torque.

NOTE In this way the pressure exerted by the fastening elements will be uniformly distributed on the joint surface.

For the maintenance intervals, see 2.1.1 (REGULAR SERVICE INTERVALS CHART).

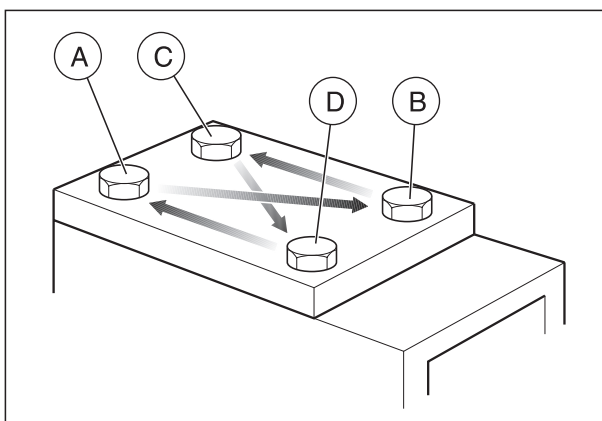

1.10.3 DRIVING TORQUES

Steel/aluminium fastening screws with similar coefficient of elasticity

Screw or bolt thread	Driving torque	
	Nm	kgm
M4	3	0.3
M5	6	0.6
M6	10	1.0
M8	25	2.5
M10	50	5.0
M12	86	8.6

⚠ CAUTION

The fastening elements featured in the table must be torqued to specification using a torque spanner and LOCTITE® applied, where indicated.

The elements marked (●) are particularly important for safety.

NOTE For the engine component driving torques, refer to the engine service and repair manual, see 0.4.1 (ENGINE SERVICE AND REPAIR MANUALS).

KEY

L243 = fasten with LOCTITE® 243

L572 = fasten with LOCTITE® 572

L574 = fasten with LOCTITE® 574

man. = fasten by hand

O = oil with motor oil

STD = tighten by applying the STANDARD driving torques

W = **aprilia** part# 8116043 (ANTI-SEIZE MOTAGEPASTE AS 1800 antiscuff paste)

ENGINE					
Fastening of engine to frame					
Description	Q.ty	Screw/nut	Nm	kgm	Notes
●Front connection	2+2	M10	50	5.0	–
●Left-side upper and lower rear connection	2	M10	50	5.0	–
●Adjusting bush right-side upper and lower rear connection	2	M20x1.5	12	1.2	O
●Lock ring right-side upper and lower rear connection	2	M20x1.5	50	5.0	–
●Screw right-side upper and lower rear connection	2	M10	50	5.0	–
Elements fastened to the engine					
Description	Q.ty	Screw/nut	Nm	kgm	Notes
Engine oil inlet flange	2	M6	10	1.0	–
Engine oil outlet flange.	2	M6	10	1.0	–
Engine oil drain plug	1	M8	10	1.0	–
Rear brake lever mount fastening	1	M6	10	1.0	–
	1	M8	25	2.5	–
Rear brake pump mount fastening	2	M8	25	2.5	–
●Pinion fastening	1	M10	50	5.0	L
Clutch control cylinder fastening	3	M6	10	1.0	–
Pinion case fastening	3	M6	10	1.0	–
Fastening of fuel delivery pipe to throttle body	1	M12x1.5	22	2.2	–
Coolant drain screw	1	M6	10	1.0	–
Coolant thermistors	2	M14	30	3.0	L
Gearshift lever fastening screw	1	M6	10	1.0	O

REAR FORK					
Description	Q.ty	Screw/nut	Nm	kgm	Notes
●Fork pin metal ring	1	M30x1.5	60	6.0	–
●Rear fork pin adjusting bush	1	M30x1.5	12	1.2	O
●Fork pin nut	1	M20x1.5	90	9.0	–
●Caliper mount locking pin	1	M12	50	5.0	L
Chain tightener screw and nut	1+1	M8	man.		O
Brake pipe grommet fastening	2	M5	4	0.4	–
Chain case fastening	2	M5	4	0.4	–
Chain tightener shoe fastening	2	M5	3	0.3	–
Rear mudguard fastening	2+2	M5	3	0.3	–

Follow ►

Follow ►

SIDE STAND					
Description	Q.ty	Screw/nut	Nm	kgm	Notes
Fastening of stand plate to frame	2	M10	40	4.0	O
Stand fastening pin	1	M10x1.25	10	1.0	–
Switch fastening screw	1	M6	10	1.0	L
Lock nut	1	M10x1.25	30	3.0	–

FRONT SUSPENSION					
Front fork					
Description	Q.ty	Screw/nut	Nm	kgm	Notes
●Fastening of upper plate on fork tubes	1+1	M8	25	2.5	–
●Fastening of lower plate on fork tubes	2+2	M8	25	2.5	–
Steering head metal ring	1	M35x1	20	2.0	–
Steering head lock ring	1	M35x1	man. + 1/4 turn		–
Steering shock absorber bush	2	M8	22	2.2	–
Upper plate fastening plug	1	M29x1	100	10.0	O
Lower plate travel-end bush fastening screw	1+1	M8	22	2.2	–
Centre screw	1+1	M10x1.5	35	3.5	–
Slider upper plug/pumping element	1+1	–	35	3.5	–
Slider upper plug	1+1	–	35	3.5	–
●Fork/wheel pin clamp cover	2+2	M8	22	2.2	–
Steering damper					
Description	Q.ty	Screw/nut	Nm	kgm	Notes
Fastening of shock absorber collar on dashboard/front fairing mount	1	M6	10	1.0	–
Tube end lock nut	1	M8	12	1.2	–
Safety dowel on shock absorber collar	1	M5	5	0.5	–
Fastening of shock absorber tube on lower plate	1	M6	10	1.0	–

REAR SUSPENSION					
Shock absorber					
Description	Q.ty	Screw/nut	Nm	kgm	Notes
●Fastening of shock absorber to frame	1	M10	50	5.0	–
Linkage					
Description	Q.ty	Screw/nut	Nm	kgm	Notes
●Fastening of single connecting rod to frame	1	M10	50	5.0	–
●Fastening of single/double connecting rod to frame	1	M10	50	5.0	–
●Fastening of double connecting rod fork	1	M10	50	5.0	–
●Fastening of double connecting rod / shock absorber	1	M10	50	5.0	–

ELECTRIC SYSTEM					
Description	Q.ty	Screw/nut	Nm	kgm	Notes
Fastening of battery clamping bracket	1	M6	3	0.3	–
Fastening of horn mount	1	M8x1.25	25	2.5	–
Fastening of speed sensor on rear brake caliper mount	1	M6	12	1.2	–
Fastening of rear indicators	2	M6	2-3	0.2-0.3	–
Fastening of electronic unit protection case	3	SWP3.9	STD	STD	–

Follow ►

ELECTRIC SYSTEM					
Description	Q.ty	Screw/nut	Nm	kgm	Notes
Fastening of voltage regulator	2	M6	12	1.2	–
Fastening of front indicators	2	M6	2-3	0.2-0.3	–
Fastening of coil to mount	8	M5	5	0.5	–
Fastening of rear light to rear fairing end	2	SWP3.9	STD	STD	–
Fastening of headlight to front fairing	3	SWP3.9	STD	STD	–
	1	M6	4	0.4	–
Fastening of relay box to dashboard/front fairing mount	2	M6	3	0.3	–
Fastening of cables to relay	2	M6	4	0.4	–
Fastening of fuse box to dashboard/front fairing mount	2	M6	3	0.3	–
Fastening of earth to frame	1	M6	10	1.0	–
Fastening of relay cable to starter	1	M6	5	5.0	–

FRONT WHEEL					
Description	Q.ty	Screw/nut	Nm	kgm	Notes
●Wheel pin nut	1	M25x1.5	80	8.0	–

REAR WHEEL					
Description	Q.ty	Screw/nut	Nm	kgm	Notes
Fastening of sprocket on sprocket holder	5	M10	50	5.0	–
Wheel pin nut	1	M25x1.5	120	12.0	–

COOLING SYSTEM					
Description	Q.ty	Screw/nut	Nm	kgm	Notes
Thermal switch on 3-way manifold	1	M14x1.5	30	3.0	L
Fastening of electrofan mount	2+2	M6	6	0.6	–
Fastening of electrofan motor to mount	3+3	M4	2	0.2	L
Radiator coolant drain plugs	1+1	M6	10	1.0	L
Fastening of expansion tank to coils mount	2	M6	10	1.0	–
Fastening of expansion tank cap	1	M28x3	man.		–
Fastening of coolant filler neck	1	M6	10	1.0	–
Fastening of hose clamps	–	–	3	0.3	–

BRAKING SYSTEMS					
Front system					
Description	Q.ty	Screw/nut	Nm	kgm	Notes
●Fastening of right and left brake caliper	2+2	M10x1.25	50	5.0	–
Fastening of brake fluid tank	1	M6	7	0.7	–
Fastening of brake fluid tank bracket	1	M6	10	1.0	–
●Brake disc fastening	6+6	M8	30	3.0	L
●Fastening of the front brake pipe	1+1+1	M10x1.25	20	2.0	–
Fastening of locking bracket of front brake three-way connection	1	M5	3	0.3	–
●Brake fluid bleeder	3	M10x1	15	1.5	–
Rear system					
Description	Q.ty	Screw/nut	Nm	kgm	Notes
●Brake caliper fastening	2	M8	25	2.5	–
Brake lever pin	1	M8	15	1.5	L
Fastening of brake fluid tank	1	M5	1	0.1	–
Brake pump fastening	2	M6	12	1.2	–
Brake rod lock nut	1	M6	man.		–
●Brake disc fastening	5	M8	30	3.0	L
●Brake pipe fastening	1+1	M10x1	20	2.0	–
●Brake fluid bleeder	1	M10x1	15	1.5	–
Brake lever support front fastening	1	M8	25	2.5	–
Brake lever support rear fastening	1	M6	12	1.2	–

Follow ►

CLUTCH CONTROL					
Description	Q.ty	Screw/nut	Nm	kgm	Notes
Fastening of clutch fluid pipe	1	M10x1	20	2.0	–
Fastening of fluid tank bracket	1	M6	10	1.0	–
Fastening of clutch fluid tank on mount	1	M5	3	0.3	–
Clutch fluid bleeder	1	M10x1	15	1.5	–

EXHAUST SYSTEM					
Description	Q.ty	Screw/nut	Nm	kgm	Notes
Fastening of exhaust pipes to engine	3+3	M8	25	2.5	–
Exhaust silencer fastening	1	M8	25	2.5	–
Exhaust pipe CO plug	1+1	G1/8"	25	2.5	W

FUEL TANK					
Fuel pump flange					
Description	Q.ty	Screw/nut	Nm	kgm	Notes
Fuel return fitting	1	M6	6	0.6	L
Fastening of pump mount to flange	3	M5	4	0.4	–
Fastening of electric terminals on flange	2	M5	5	0.5	–
Closing of fuel return	1	M6	10	1.0	L
●Fastening of fuel delivery pipe on flange	1	M12x1.5	22	2.2	–
Petrol level sensor on pump mount	2	SWP 2.9	1	0.1	–
Fastening of fuel pump cables on flange	2	M6	10	1.0	–
Fuel tank					
Description	Q.ty	Screw/nut	Nm	kgm	Notes
Fastening of filler to tank	3	M5	5	0.5	–
Fastening of fuel pump flange on tank	8	M6	6	0.6	–
Fastening of tank front on frame	2	M6	12	1.2	–
Fastening of tank rear on mount	1	M6	12	1.2	–

ENGINE OIL TANK AND RADIATOR					
Description	Q.ty	Screw/nut	Nm	kgm	Notes
Tank upper fastening screw	1	M6	10	1.0	–
Tank fastening nut	2	M6	10	1.0	–
Oil filter	1	M20x1.5	30	3.0	–
Oil drain plug	1	M8	15	1.5	–
Oil level pipe fittings	2	M10x1	20	2.0	–
Radiator fastening screw	3	M6	12	1.2	–

FRAME/FAIRINGS					
Description	Q.ty	Screw/nut	Nm	kgm	Notes
Radiator spoiler fastening	3	M6	4	0.4	–
Fastening of number plate holder to rear mudguard extension	2	M5	2	0.2	–
Fastening of reflector holder to number plate holder	2	M5	6	0.6	–
Front mudguard fastening	4	M5	5	0.5	O
Rearview mirror fastening nut	1+1	M6	8	0.8	–
Fastening of rearview mirror mounts and front fairing to mount	4	M5	5	0.5	–
Lower fastening of front fairing to conveyors	2	M5	4	0.4	–
Lower fastening of front fairing (on upper part)	2	M5	4	0.4	–
Fastening of conveyors to frame and mount	14	SWP 3.9	STD	STD	–

Follow ►

FRAME/FAIRINGS					
Description	Q.ty	Screw/nut	Nm	kgm	Notes
Fastening of conveyor covers	6	M6	5	0.5	–
Fastening of side fairing upper panel	2+2	M5	front 1 rear 2	0.1 0.2	–
Fastening of dashboards upper protection moulding	4	M6	2	0.2	–
Fastening of lower fairing to frame	4	M6	5	0.5	–
Fastening of silencer protection to lower fairing	2	M6	5	0.5	–
Fastening of sides	4	M6	5	0.5	–
Fastening of saddle support bush and lower moulded cover	2	M6	5	0.5	–
Fastening of saddle support lower moulded cover	4	M6	4	0.4	–
Fastening of rear fairing to saddle support lower moulded cover	6	M6	2	0.2	–
Fastening of rear fairing end to rear fairing	2+2	M5	upper 5 lower 3	0.5 0.3	–
Fastening of rear fairing/passenger grab strap	2	M6	10	1.0	–
Fastening of internal fairing and side fairing	8	SWP 2.9	STD	STD	–
Fastening of dashboard to mount	3	M6	5	0.5	–
Fastening of riders's saddle	2	M6	12	1.2	–
Fastening of riders's saddle front mount	4	M6	12	1.2	–
Fastening of passenger seat lock	2	M6	10	1.0	–
Fastening of passenger seat lock key-operated control	2	M6	12	1.2	–
Fastening of passenger footrest supports	4	M8	25	2.5	–
Fastening of riders's footrest supports	4	M8	25	2.5	–
Fastening of lower fairing support bracket	2	M6	12	1.2	–
Fastening of riders's footrest protection	4	M5	6	0.6	–
Fastening of saddle support	4	M10	50	5.0	O
Fastening of coil mounts	4	M6	12	1.2	–
Fastening of dashboard/front part of the fairing to frame	2	M6	12	1.2	–
Fastening of front lower cover	3	M6	7	0.7	–

RIGHT/LEFT HANDLEBARS AND CONTROLS					
Description	Q.ty	Screw/nut	Nm	kgm	Notes
Fastening of anti-vibration weights	1+1	M6	10	1.0	–
Anti-vibration weights metal ring	1+1	M18x1	35	3.5	–
●Fastening of right/left handlebars to the fork	1+1	M8	25	2.5	–
Handlebars lock screw	1+1	M6	10	1.0	–
Fastening of left dimmer switch	1	M5x1	2	0.2	–
Fastening of right dimmer switch	1	M4	2	0.2	–
●Fastening of the front brake control lever	2	M6	8	0.8	–
●Fastening of clutch lever	2	M6	8	0.8	–

AIR FILTER CASING					
Description	Q.ty	Screw/nut	Nm	kgm	Notes
Fastening of air filter casing cover	7	M5	2	0.2	–
Fastening of air filter casing to throttle body	6	M6	7	0.7	O
Fastening of intake conveyors	4	SWP3.9	STD	STD	–
Fastening of air sensor support plate	1	SWP3.9	STD	STD	–
Reduction diaphragm	1	SWP3.9	1	0.1	–
Suction coupling clamp	1	–	2	0.2	–
Filter case front support	2	M6	8	0.8	–

Follow ►

THROTTLE BODY					
Description	Q.ty	Screw/nut	Nm	kgm	Notes
Injector support fastening screw	3+2	M6	9	0.9	–
Pressure regulator fastening screw	2	M6	3.5	0.35	–
Throttle cable support bracket fastening screw	3	M5	3	0.3	–
Throttle cable pullet fastening nut	1	M8	3	0.3	–
Throttle valve control lever fastening nut	1	M8	3	0.3	–
Throttle valve potentiometer fastening screw	2	M4	1.6	0.16	–
Intake flange fastening screw	2+2	M8	19	1.9	–

1.11 INSTRUCTIONS FOR APPLYING TRANSFERS

When removing parts of the frame:

⚠ CAUTION

Handle the plastic and painted components with care to avoid scraping or damaging them. Proceed with care. Do not damage the tangs and/or their seats.

When applying the transfers, follow the instructions given below carefully.

It is advisable to use the following tools:

- relatively stiff spatula (1);

NOTE Generally, soft, squeegee-type spatulas do not remove enough water from under the transfer.

- sponge or sprayer (2) with water.

NOTE Add detergent to the water (1-3%) and shake until you get soap bubbles.

Apply as follows:

- ◆ Place the transfer (3) upside down on a work surface.
- ◆ Keeping the transfer spread out on the work surface, remove the protective backing (4) completely.

NOTE It is advisable to use a sprayer (2).

When using a sponge, dab the surface with the sponge, without pressing hard so as to avoid damaging the adhesive.

- ◆ Wet the surface of the adhesive with soapy water.
- ◆ Apply the transfer (3) on the surface to be decorated and move it into the right position.

NOTE Always move the spatula in constant strokes from the centre of the transfer out.

- ◆ Using the spatula (1), press down reasonably hard and move the spatula across the surface of the transfer until the excess soap and water has been removed from underneath.

NOTE Do not lift the corners and/or sides of the transfer.

- ◆ Use an absorbent cloth and, working from the centre out, dry the transfer.
- ◆ Move the spatula over the transfer again with firm, even strokes, pressing down as hard as possible. Move the spatula in strokes from the centre out, taking special care with the corners and sides to make sure the whole surface sticks evenly.

Follow ►

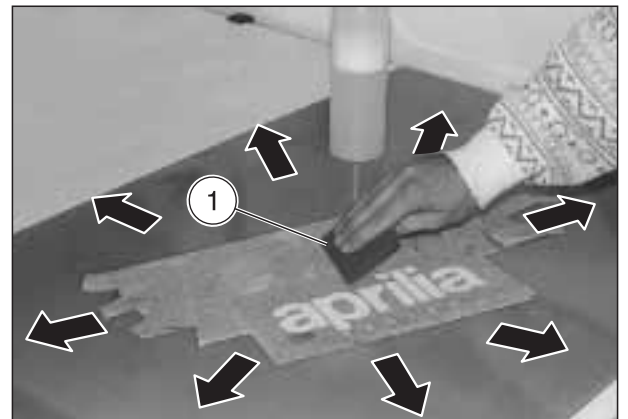
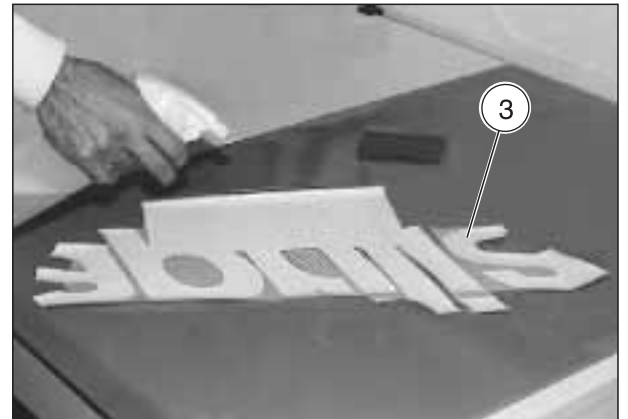
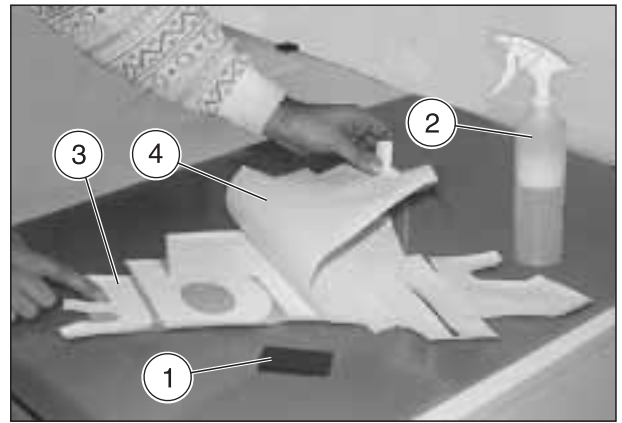

Follow ►

NOTE Where the transfer features application tape (5)*, the tape must be removed 20-30 minutes after the application of the transfer.

* The application tape is used to facilitate the application of trademarks and letters, arranging them in the correct place on the surface to be decorated, and to give the self-adhesive more body during application.

- ◆ Remove the application tape (5) from the surface of the transfer.
- ◆ In order to assure good adhesion, move the spatula over the transfer again, concentrating in particular on the edges and corners.

NOTE With the wet method, the final level of the transfer is reached approx. 48 hours after application.

- ◆ Once the application tape has been removed, make sure there are no air bubbles anywhere on the surface.

In the event air bubbles are encountered:

- ◆ Use a pin or paper cutter (6) to make a hole in the edge (7) of the air bubble.
- ◆ Using the spatula (1), work from the edge opposite the hole and push the bubble so the air escapes.

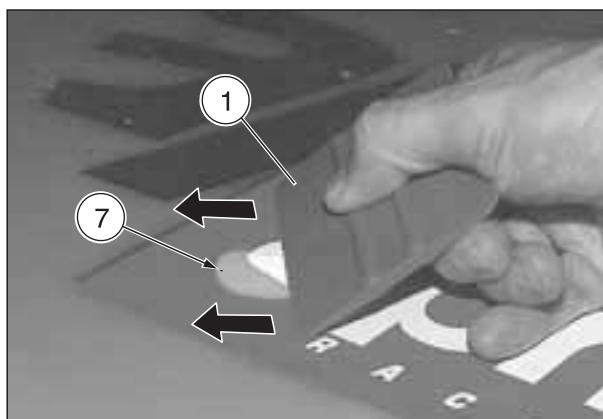
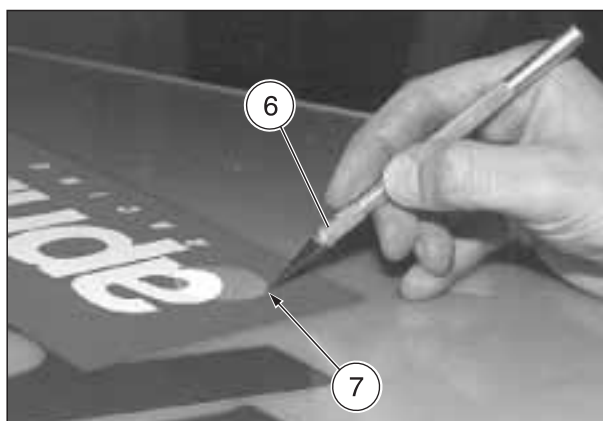
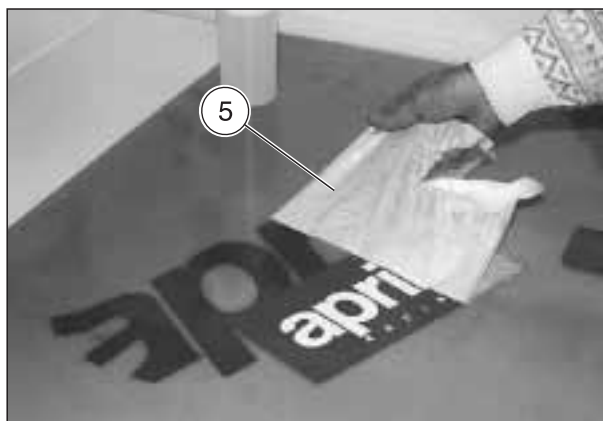

NOTES

THIS PAGE HAS BEEN INTENTIONALLY LEFT EMPTY

SERVICE AND SETTING UP

2

SERVICE AND SETTING UP

TABLE OF CONTENTS

2.1 PERIODIC SERVICE PLAN	2-3-00
2.1.1 REGULAR SERVICE INTERVALS CHART	2-4-00
2.2 POINTS REQUIRING LUBRICATION	2-6-00
2.2.1 LUBRICATION CHART	2-6-00
2.3 MULTIFUNCTION COMPUTER	2-8-00
2.3.1 SEGMENT OPERATION CHECK	2-8-00
2.3.2 SWITCHING FROM km TO mi (from km/h to MPH) AND VICEVERSA (LEFT DISPLAY)	2-9-00
2.3.3 SETTING THE INSTANTANEOUS, MAXIMUM AND AVERAGE SPEED (LEFT DISPLAY)	2-9-00
2.3.4 SETTING THE RED LINE THRESHOLD (WITH ENGINE OFF ONLY)	2-10-00
2.3.5 MULTIFUNCTION (RIGHT DISPLAY)	2-11-00
2.3.6 STANDARD SETTING: COOLANT TEMPERATURE AND DIGITAL CLOCK	2-11-00
2.3.7 BATTERY VOLTAGE - VBATT	2-11-00
2.3.8 SETTING THE HOUR	2-12-00
2.3.9 SETTING THE MINUTES	2-12-00
2.3.10 SETTING °C OR °F	2-12-00
2.3.11 CHRONOMETER (RIGHT DISPLAY)	2-13-00
2.3.12 DIAGNOSTICS	2-13-00
2.4 BATTERY	2-14-00
2.4.1 CHECKING AND CLEANING THE TERMINALS	2-14-00
2.4.2 RECHARGING THE BATTERY	2-15-00
2.4.3 LONG INACTIVITY OF THE BATTERY	2-15-00
2.5 ELECTRIC COMPONENTS	2-16-00
2.6 JUMP-STARTING	2-17-00
2.7 SPARK PLUGS	2-18-00
2.8 LIFTING THE FUEL TANK	2-20-00
2.9 DRAINING THE FUEL TANK	2-20-00
2.10 AIR CLEANER	2-22-00
2.11 ACCELERATOR	2-23-00
2.11.1 CHECKING THE OPERATION OF THE ACCELERATOR CONTROL	2-23-00
2.11.2 IDLING ADJUSTMENT	2-23-00
2.11.3 ADJUSTING THE ACCELERATOR CONTROL	2-24-00
2.12 COLD START CABLE	2-24-00
2.13 CHECKING THE ENGINE OIL LEVEL AND TOPPING UP	2-25-00
2.14 CHANGING THE ENGINE OIL AND THE OIL FILTER	2-26-00
2.15 CHECKING AND TOPPING UP COOLANT	2-28-00
2.16 CHANGING THE COOLANT	2-29-00
2.17 CHECKING AND TOPPING UP THE FRONT BRAKE FLUID	2-31-00
2.18 CHECKING AND TOPPING UP THE REAR BRAKE FLUID	2-32-00
2.19 CHECKING AND TOPPING UP THE CLUTCH FLUID	2-34-00
2.20 BLEEDING THE BRAKING SYSTEMS ..	2-35-00
2.20.1 BLEEDING OPERATIONS	2-36-00
2.20.2 CHECKS TO BE CARRIED OUT AFTER BLEEDING THE BRAKING SYSTEMS	2-37-00
2.21 BLEEDING THE CLUTCH SYSTEMS	2-38-00
2.21.1 BLEEDING OPERATIONS	2-38-00
2.21.2 CHECKS TO BE CARRIED OUT AFTER BLEEDING THE CLUTCH CONTROL SYSTEM	2-39-00
2.22 CHANGING THE FRONT BRAKE FLUID	2-40-00
2.23 CHANGING THE REAR BRAKE FLUID ..	2-41-00
2.24 CHANGING THE CLUTCH FLUID	2-42-00
2.25 ADJUSTING THE REAR BRAKE CONTROL LEVER AND THE GEAR LEVER	2-42-00
2.26 ADJUSTING THE REAR BRAKE CONTROL LEVER CLEARANCE	2-43-00
2.27 CHECKING THE BRAKE PAD WEAR ...	2-44-00
2.28 STEERING	2-46-00
2.28.1 CHECKING THE BEARING SLACK STEERING	2-46-00
2.28.2 ADJUSTING THE BEARING SLACK STEERING	2-46-00
2.29 INSPECTING THE FRONT AND REAR SUSPENSION	2-48-00
2.29.1 FRONT SUSPENSION	2-48-00
2.29.2 ADJUSTING THE FRONT FORK	2-49-00
2.29.3 ADJUSTING THE HEIGHT OF THE FORECARRIAGE	2-50-00
2.30 REAR FORK	2-51-00
2.30.1 ADJUSTING THE REAR FORK	2-51-00
2.31 INSPECTING THE REAR SUSPENSION (models up to 2001)	2-52-00
2.31.1 REAR SUSPENSION	2-52-00
2.31.2 ADJUSTING THE REAR SHOCK ABSORBER	2-52-00
2.32 INSPECTING THE REAR SUSPENSION <small>RSV01</small>	2-54-00
2.32.1 REAR SUSPENSION	2-54-00
2.32.2 ADJUSTING THE REAR SHOCK ABSORBER	2-54-00
2.32.3 CHECKING THE REAR SUSPENSION LINKAGE	2-56-00
2.33 FRONT WHEEL	2-56-00
2.34 REAR WHEEL	2-57-00
2.35 EXHAUST MANIFOLD NUTS	2-57-00
2.36 DRIVE CHAIN	2-58-00
2.36.1 CHECKING THE DRIVE CHAIN SLACK	2-58-00
2.36.2 CHECKING THE DRIVING CHAIN, PINION AND SPROCKET WEAR	2-59-00
2.36.3 ADJUSTING THE DRIVING CHAIN	2-59-00
2.36.4 DRIVE CHAIN TENSION AND LUBRICATION	2-59-00
2.36.5 INSPECTING THE DRIVING CHAIN GUIDE PLATE	2-60-00
2.36.6 INSPECTING THE DRIVING CHAIN SHOE	2-60-00
2.37 TYRES	2-61-00
2.37.1 CONDITION OF TREAD	2-61-00
2.37.2 INFLATION PRESSURE	2-62-00
2.38 FUEL PIPES	2-63-00
2.39 BRAKE AND CLUTCH PIPES	2-63-00
2.40 COOLING SYSTEM PIPES	2-63-00
2.41 CHECKING THE SIDE STAND	2-64-00
2.42 NUT, BOLT, SCREW TIGHTENING	2-65-00
2.43 VALVES	2-65-00
2.44 CLUTCH	2-65-00
2.45 PISTONS	2-65-00

This section describes the procedures for periodic service on the principal components of the vehicle.

⚠ WARNING

Before beginning any maintenance operation or any inspection of the vehicle, stop the engine, extract the key from the ignition block, wait until the engine and the exhaust system have cooled down and if possible lift the vehicle by means of the proper equipment, on firm and flat ground.

Keep away from the red-hot parts of the engine and of the exhaust system, in order to avoid burns.

If not expressly indicated otherwise, for the reassembly of the units repeat the disassembly operations in reverse order.



2.1 PERIODIC SERVICE PLAN

aprilia recommends respecting the intervals indicated for the periodic service on the various components in order to ensure the best operating conditions of the vehicle.

⚠ CAUTION

After the first 1000 km (625 mi) and successively every 7500 km (4687 mi), the writing "SERVICE" (1) appears on the right display.

In this case, carry out the operations prescribed in the periodic service plan. If the bike is being used for competition, perform the operations more frequently, see 2.1.1 (REGULAR SERVICE INTERVALS CHART).

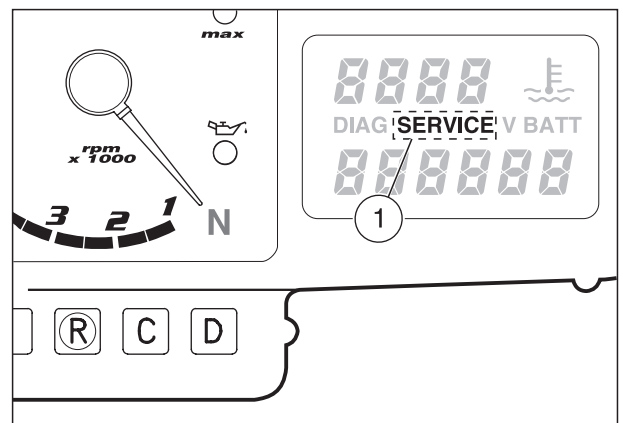

2.1.1 REGULAR SERVICE INTERVALS CHART

OPERATIONS TO BE CARRIED OUT BY THE aprilia Official Dealer (WHICH CAN BE CARRIED OUT EVEN BY THE USER).

KEY

- ① = check and clean, adjust, lubricate or change, if necessary;
- ② = clean;
- ③ = change;
- ④ = adjust.

NOTE Perform the maintenance operations with doubled frequency if the vehicle is used in rainy or dusty areas, on uneven surfaces or on racetracks.

(*a) = In case of use on racetracks, change every 3750 km (2343 mi).

(*b) = Check every two weeks or according to the intervals indicated.

Components	After running-in [1000 km (625 mi)]	Every 7500 km (4687 mi) or 12 months	Every 15000 km (9375 mi) or 24 months
Spark plugs (*a)	–	①	③
Stand	①	①	–
Air cleaner	–	①	③
Engine oil filter (*b)	③	③	–
Engine oil filter (on oil tank)	②	–	②
Fork	①	–	①
Light operation/direction	–	①	–
Light system	①	①	–
Safety switches			
Clutch fluid	–	①	–
Brake fluid	–	①	–
Coolant	–	–	①
Engine oil (*b)	③	③ (*a)	–
Tyres	①	①	–
Tyre pressure (*c)	④	④	–
Engine idling rpm	④	④	–
Battery terminal tightening	①	①	–
Engine oil pressure warning light LED	at every start: ①		
Drive chain tension and lubrication	every 1000 km (625 mi): ①		
Brake pad wear	①	before every trip and every 2000 km (1250 mi): ①	

TABMAN-M2-U-UK

Follow ►

Follow ►

**OPERATIONS TO BE CARRIED OUT BY THE aprilia
Official Dealer.****KEY**

- ① = check and clean, adjust, lubricate or change, if necessary;
 ② = clean;
 ③ = change;
 ④ = adjust.

NOTE Perform the maintenance operations with doubled frequency if the vehicle is used in rainy or dusty areas, on uneven surfaces or on racetracks.

(*a) = With "R" fork **RSV R** (**RSV OPT**), change every 10000 km (6250 mi).

(*b) = **Only in case of:**
 – **intense use on racetracks;**
 – **participation in competitions.**

(*c) = In case of use on race tracks, check every 3750 km (2343 mi).

Components	After running-in [1000 km (625 mi)]	Every 7500 km (4687 mi) or 12 months	Every 15000 km (9375 mi) or 24 months
Rear shock absorber	–	–	①
Accelerator cables (adjustment)	①	①	–
Carburation, CO adjustment	①	①	–
Transmission cables and controls	①	①	–
Rear suspension linkage bearings	–	–	①
Steering bearings and steering clearance	①	①	–
Rear fork bearings and rear fork slack	①	①	–
Wheel bearings	–	①	–
Brake discs	①	①	–
General running of the vehicle	①	①	–
Braking systems	①	①	–
Clutch control system	①	①	–
Cooling system	–	①	–
Clutch fluid	every 2 years: ③		
Brake fluid			
Coolant			
Fork oil (*a)	after the first 7500 km (4687 mi) and successively every 22500 km (14000 mi): ③		
Fork oil seals	after the first 30000 km (18750 mi) and successively every 22500 km (14000 mi): ③		
Brake pads	if worn: ③		
Pistons (*b)	every 5000 km (3125 mi): ①		
Adjusting the valve clearance	④	–	④
Wheel/Tyres	①	①	–
Nut, bolt, screw tightening	①	①	–
Cylinder synchronization	①	①	–
Suspensions and attitude	①	–	①
Clutch fluid bleeding	①	–	–
Brakes fluid bleeding	①	–	–
Final transmission (chain, crown and pinion)	–	①	–
Fuel pipes	–	①	every 4 years: ③
Brakes and clutch pipes	–	①	every 4 years: ③
Cooling system pipes	–	①	–
Clutch wear (*c)	–	①	–

TABMAN-M2-C-UK

2.2 POINTS REQUIRING LUBRICATION

Correct lubrication is important for good performance and the long life of the vehicle.

NOTE Before lubricating, completely clean all parts, removing rust, grease, dirt and dust.

The exposed parts subject to rust are to be lubricated with motor oil or grease, see 1.6 (LUBRICANT CHART).

The points to be lubricated are indicated in the "LUBRICATION CHART".

2.2.1 LUBRICATION CHART

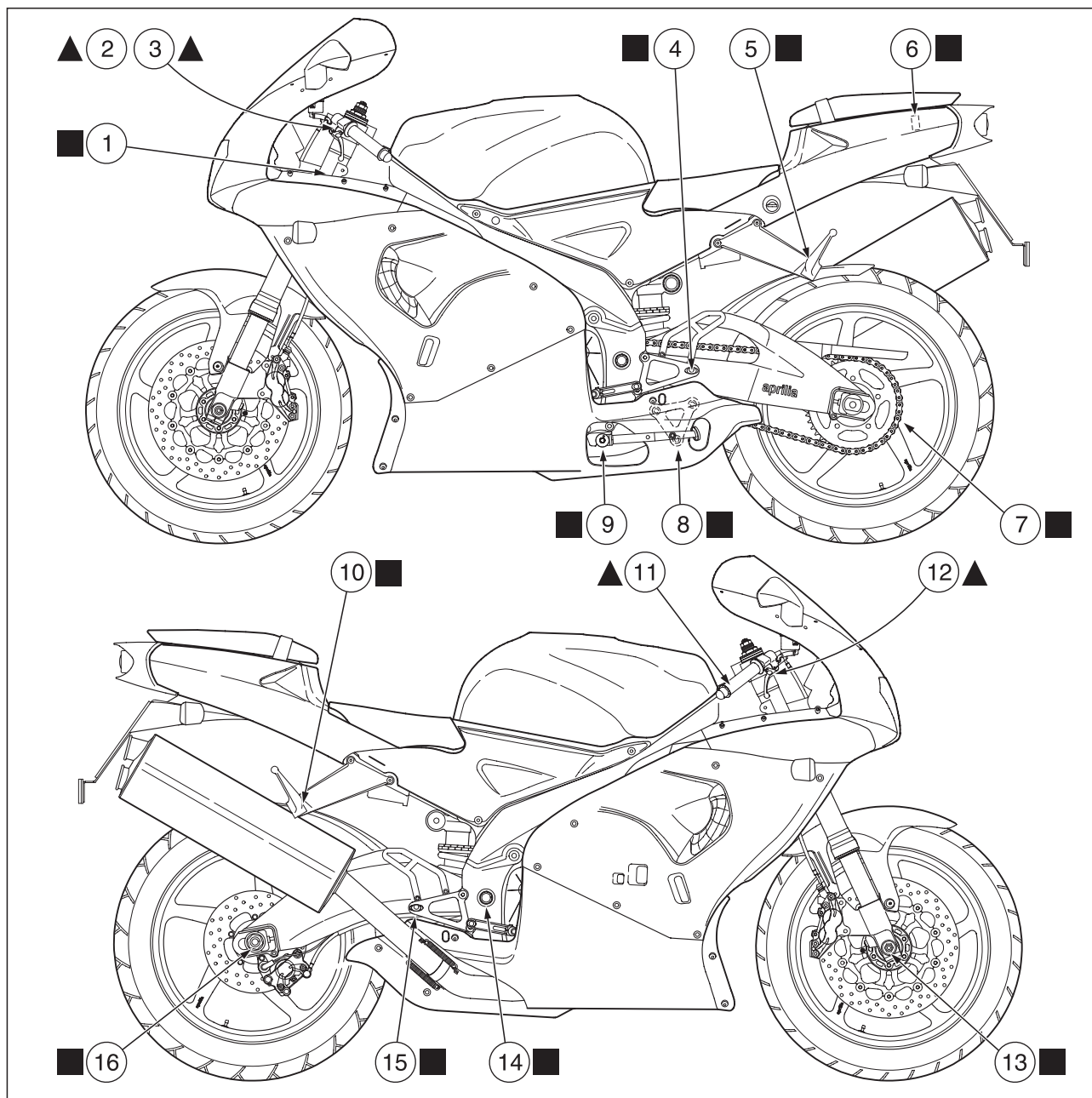

Follow ►

Follow ►

LUBRICATION CHART KEY

- 1) Steering bearings
- 2) Clutch lever pin
- 3) Lever cable for cold starting
- 4) Rider left footrest pin
- 5) Passenger left footrest pin
- 6) Passenger seat lock
- 7) Drive chain
- 8) Rear suspension leverage
- 9) Side stand pin
- 10) Passenger right footrest pin
- 11) Throttle grip
- 12) Accelerator cables
- 13) Front wheel pin and bearings
- 14) Rear fork pin
- 15) Rider right footrest pin
- 16) Rear wheel pin and bearings

■ = Grease

▲ = Oil



2.3 MULTIFUNCTION COMPUTER

KEY

- A) Left multifunction digital display (speedometer - odometer).
- B) Multifunction computer programming push buttons.
- C) Right multifunction digital display (coolant temperature - clock - battery voltage - chronometer - diagnostic).

When the ignition key (1) is rotated to position "O", the following warning lights come on on the dashboard:

- red line warning light LED "max" (2);
- red engine oil pressure warning light LED "oil" (3), which remains on until the engine starts.

The pointer (4) of the revolution counter shifts to the maximum value (rpm) set by the user. After about three seconds the red line warning light LED "max" (2) goes off; the pointer (4) of the revolution counter returns to its initial position.

The writing "E F I" (5) appears on the right side of the multifunction display for three seconds.

In this way the component operation is tested.

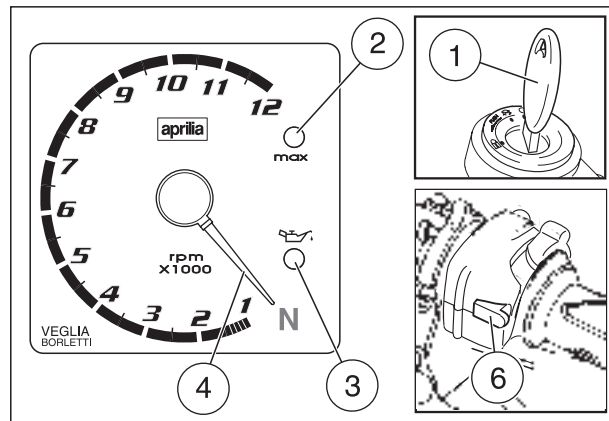
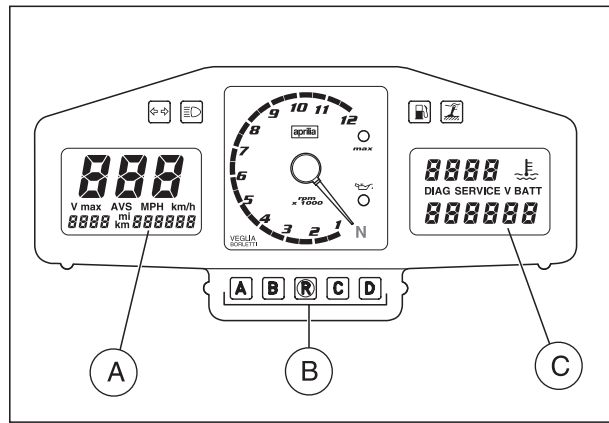

CAUTION

After the first 1000 km (625 mi) and successively every 7500 km (4687 mi), the writing "SERVICE" (5a) appears on the right display.

In this case contact an **aprilia** Official Dealer, who will carry out the operations indicated in the regular service intervals chart, see 2.1.1 (REGULAR SERVICE INTERVALS CHART). To make the writing "SERVICE" disappear, press the "LAP" push button (6) and then the push button **R** and keep them pressed for about five seconds.

With the ignition key (1) in position "O" the standard settings on the dashboard are the following:

- Right display:** Clock (7), coolant temperature in °C (8).
- Left display:** Instantaneous speed in km/h (9), trip 1 (trip odometer) (10), total kilometres/miles odometer (11).

- Upon installation of the battery or of the 30A main fuses:
- the revolution counter pointer (4) makes twelve clockwise clicks, thus checking the operation of the revolution counter itself;
- the instantaneous, maximum and average speed function is set in "km/h";
- the coolant temperature is set in °C;
- the digital clock is set to zero;
- the red line is set at 6000 rpm, indicated by the coming on of the red line warning light LED "max" (red) (2).

NOTE If necessary, carry out the appropriate adjustments.

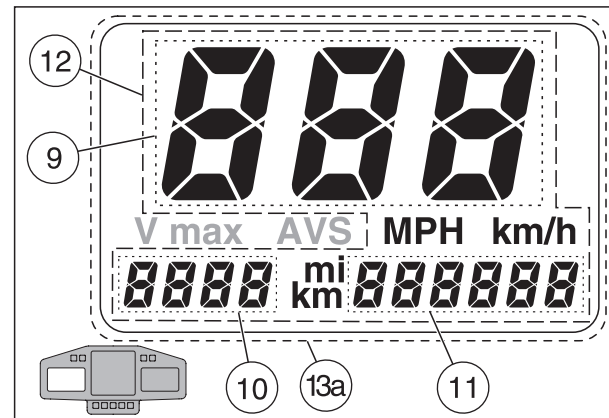

2.3.1 SEGMENT OPERATION CHECK

- ◆ Press the push buttons **A** and **B** at the same time.
- ◆ Rotate the ignition key (1) from position "I" to position "O".

All the segments (13) (13a) will remain on until the push buttons **A** and **B** are released.

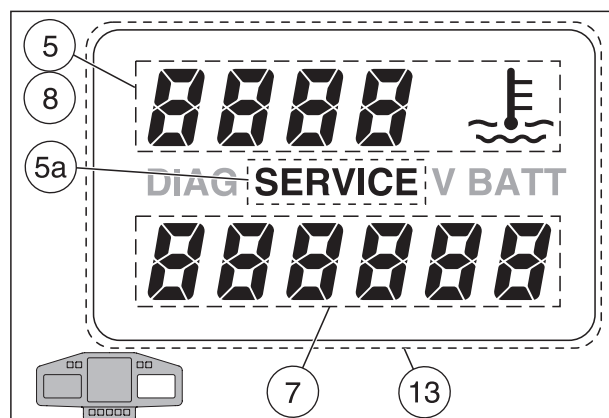

2.3.2 SWITCHING FROM km TO mi (from km/h to MPH) AND VICEVERSA (LEFT DISPLAY)

- ◆ Press the push button **A** until, after about five seconds, all the writings (12) on the left display start blinking.
- ◆ Release the push button **A**.
- ◆ Press the push button **B** to change the unit of measurement from “km” to “mi” (from “km/h” to “MPH”) or viceversa.
- ◆ To confirm the setting, press the push button **A** for about five seconds.

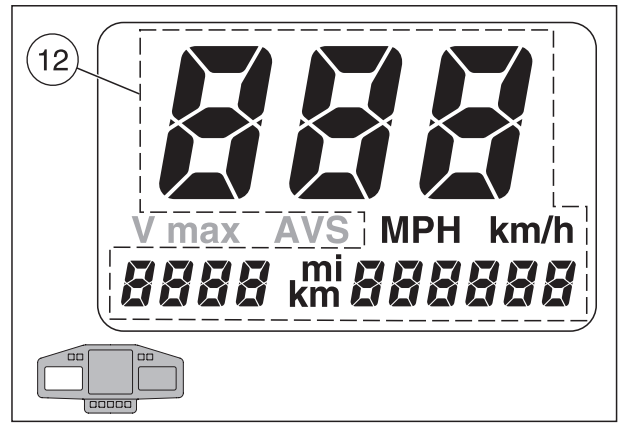

2.3.3 SETTING THE INSTANTANEOUS, MAXIMUM AND AVERAGE SPEED (LEFT DISPLAY)

NOTE Two seconds after the vehicle has started moving, the instantaneous speed is automatically shown on the display, even if a different function is set.

When the ignition key is rotated to position “O”, the instantaneous speed (9) and the partial number of kilometres/miles covered “trip 1” (10) appear on the left display. Resetting “trip 1” (10): with the odometer set on the instantaneous speed function, press the push button **R** for about two seconds.

- ◆ To display the maximum speed (14) and the distance “trip 1” (10), press the push button **B** for about one second. The writing “V max” (15), the maximum speed (14) and the distance “trip 1” (10) are displayed.

Resetting the maximum speed (14): with the odometer set on the “V max” function, press the push button **R** for about 2 seconds.

NOTE The measurement of the maximum speed is relevant to the distance covered from the last setting to zero of the maximum speed itself. The distance “trip 1” (10) shown on the display indicates the number of kilometres/miles covered from the last setting to zero, to the distance “trip 1”.

- ◆ To display the average speed (16) and the distance “trip 2” (17), press the push button **B** again for about 1 second.

The writing “AVS” (18), the average speed (16) and the distance “trip 2” (17) are displayed.

Resetting the average speed (16) and the distance “trip 2” (17): with the odometer set on the “AVS” function, press the push button **R** for about 1 second.

NOTE The measurement of the average speed is relevant to the distance “trip 2” (odometer).

The distance “trip 2” (17) shown on the display indicates the number of kilometres/miles covered from the last setting to zero.

If more than 1000 km (625 mi) are covered without setting “trip 2” to zero, the value of the average speed will be wrong.

To display the instantaneous speed (13) and the distance “trip 1” (10), press the push button **B** again.

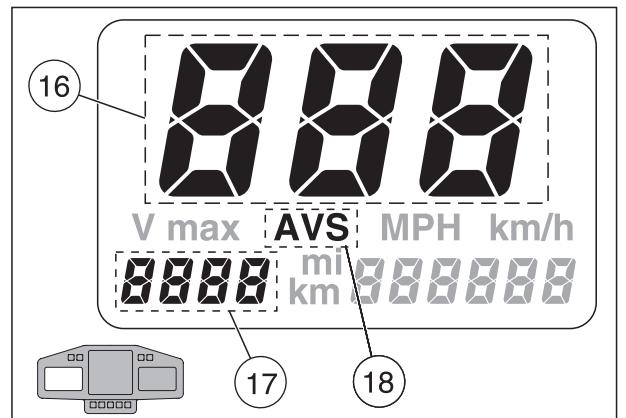
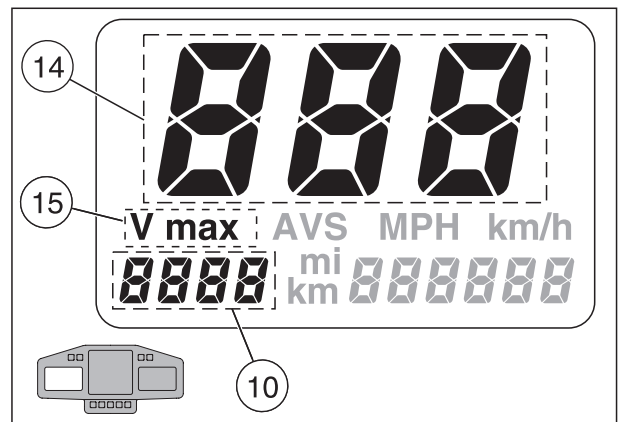
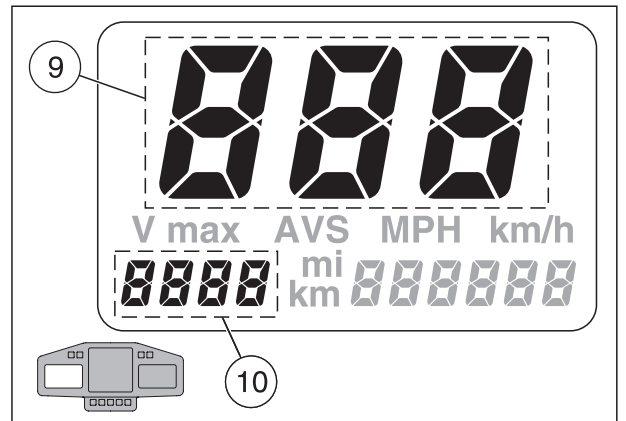

2.3.4 SETTING THE RED LINE THRESHOLD (WITH ENGINE OFF ONLY)

When the maximum rpm set is exceeded, the red line warning light LED “max” (2) positioned on the dashboard starts blinking.

If the push button **C** is pressed for less than one second, the pointer of the revolution counter (4) shifts to the red line value set for three seconds, after which it returns to its initial position.

For the adjustment, proceed as follows:

- ◆ Press the push button **C**, release it and press it **C** again within 3 seconds. The pointer (4) moves increasing the value by 1000 rpm at each click, as long as **C** is kept pressed; when it has reached the maximum value, it starts again from the beginning.
- ◆ Press the push button **C** until the desired rpm value has been set.
- ◆ If the push button **C** is released and then pressed again within 3 seconds, intermittently, the pointer (4) moves increasing the value by 100 rpm at each click; when it has reached the maximum value, it starts again from the beginning.

NOTE It is not possible to set the red line at values lower than 2000 rpm or higher than 12000 rpm.

CAUTION

Never exceed the recommended rpm, see table.

- ◆ To confirm, release the push button **C**. After three seconds, the red line threshold setting is stored.

NOTE The setting is confirmed by the coming on of the red line warning light LED “max” (2).

Engine maximum rpm recommended	
Mileage km (mi)	rpm
0 – 1000 (0 – 625)	6000
1000 – 1500 (625 – 937)	7500
over 1500 (937)	10500

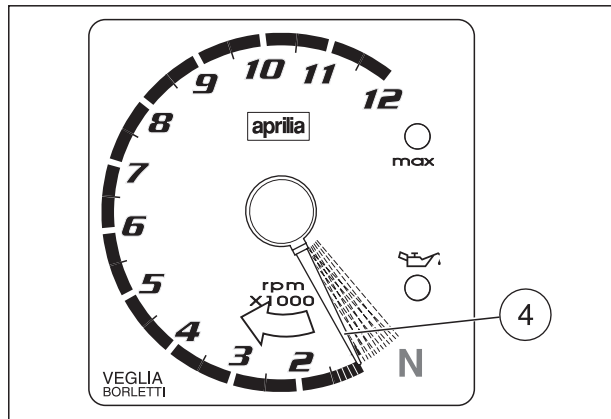
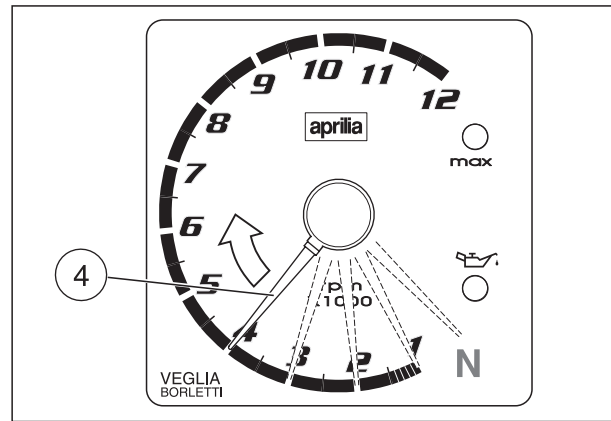
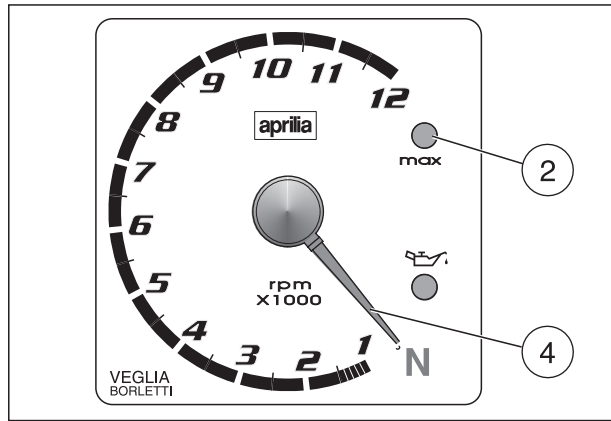

2.3.5 MULTIFUNCTION (RIGHT DISPLAY)

The right display (multifunction) includes the coolant temperature in °C (°F) (8) and the digital clock (7) as standard settings.

NOTE When the engine is cold, the writing “c o l d” blinks.

By pressing the push button **D**, the following functions can be obtained in sequence:

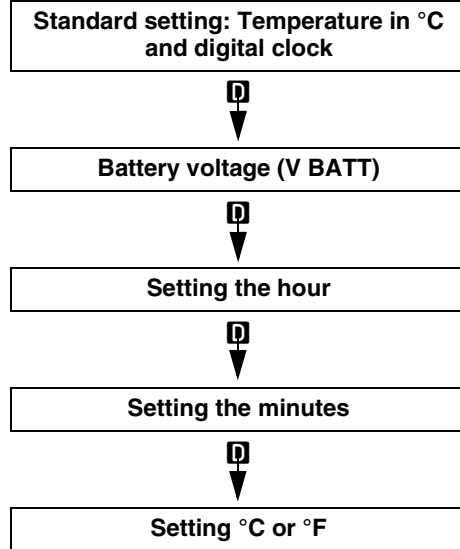

2.3.6 STANDARD SETTING: COOLANT TEMPERATURE AND DIGITAL CLOCK

The coolant temperature value (8) is shown in the upper part of the right display. It is possible to switch from °C to °F and viceversa, see 2.3.10 (SETTING °C OR °F).

- When the temperature is below 35 °C (95 °F), the writing “c o l d” (8) blinks on the right display.
- When the temperature is over 115 °C (239 °F), the value (8) blinks on the right display, even if a function different from the standard setting has been set.
- When the temperature is over 130 °C (266 °F), the writing “L L L” (8) appears on the right display.

⚠ CAUTION

If the writing “L L L” is displayed with a temperature below 130 °C (266 °F), there may be a failure of the electric circuit. In this case, contact an **aprilia Official Dealer**.

Thermometer range on the display: 35–130°C (95–266 °F).

The digital clock (7) appears in the lower part of the right display. To set or modify hour and minutes, see 2.3.8 (SETTING THE HOUR) and (SETTING THE MINUTES).

2.3.7 BATTERY VOLTAGE - VBATT

- ◆ If the push button **D** is pressed once, the battery voltage expressed in volt (19) appears in the lower part of the right display, while the coolant temperature (8) is displayed in the upper part. The writing “V BATT” (20) is displayed. The recharge circuit functions correctly if at 4000 rpm the battery voltage with low beam on is included between 13 and 15 V.

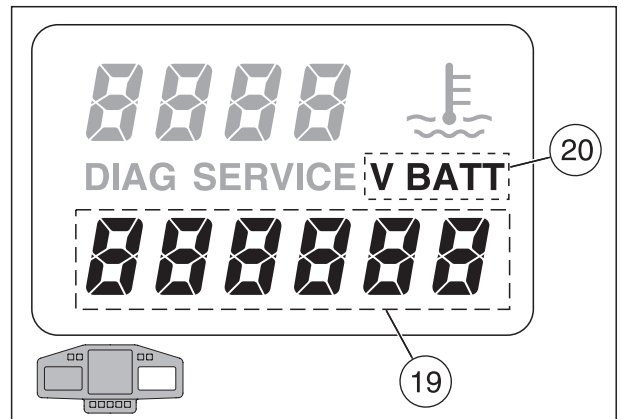
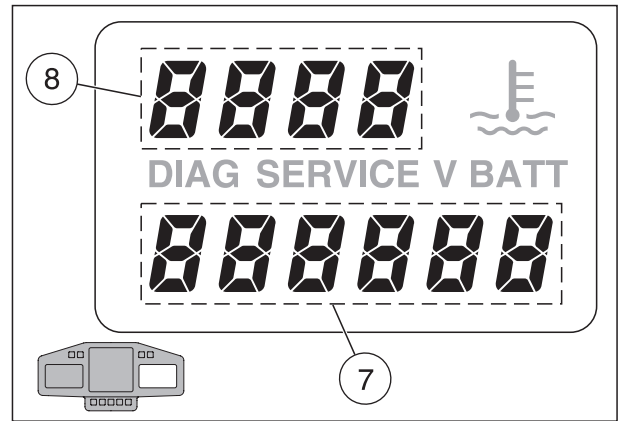

2.3.8 SETTING THE HOUR

- ◆ When the push button **D** is pressed for the second time, the hour segments (21) start blinking in the lower part of the right display (digital clock).
- ◆ To modify the hour setting, press the "LAP" push button (6) on the left part of the handlebar.
- ◆ To confirm the hour setting, press the push button **D**.

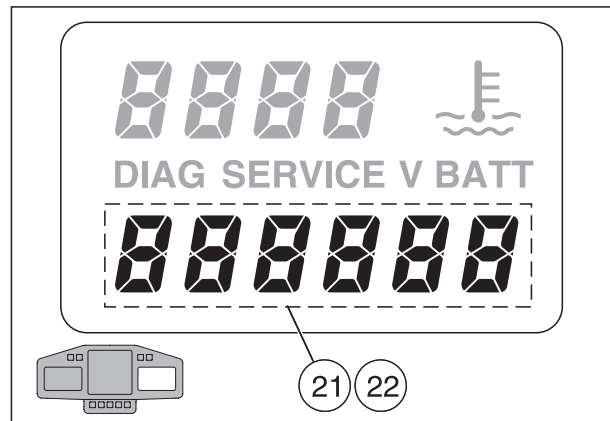

2.3.9 SETTING THE MINUTES

- ◆ When the push button **D** is pressed for the third time, the minute segments (22) start blinking in the lower part of the right display (digital clock).
- ◆ To modify the minute setting, press the "LAP" push button (6) on the left part of the handlebar.
- ◆ To confirm the minute setting, press the push button **D**.

2.3.10 SETTING °C OR °F

- ◆ When the push button **D** is pressed for the fourth time, the segments of the coolant temperature in °C or °F (8) start blinking in the upper part of the display.
- ◆ To modify from °C to °F setting, or vice versa, press the "LAP" push button (6) on the left part of the handlebar.
- ◆ To confirm the setting, press the push button **D**.

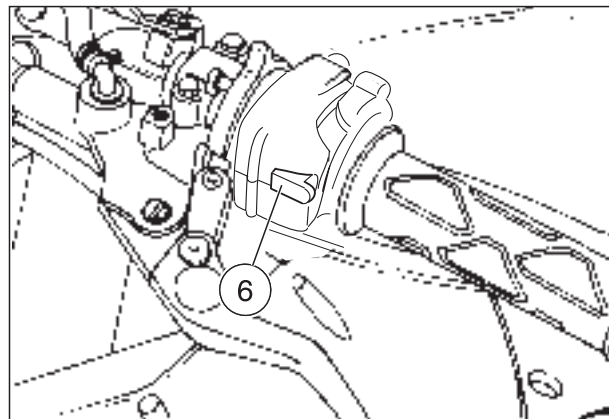
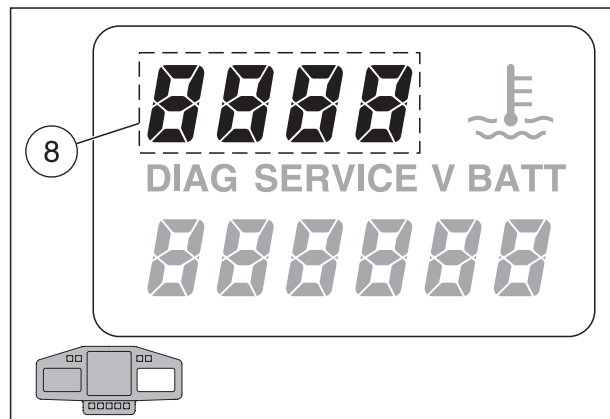

2.3.11 CHRONOMETER (RIGHT DISPLAY)

The chronometer makes it possible to measure the time per lap with the vehicle on a racetrack and to store the data, in such a way as to be able to consult them successively.

When the "CHRONOMETER" function has been selected, it is not possible to recall the following functions:

- maximum speed "V max";
- average speed "AVS";
- distance "trip 2".
- ◆ To operate the chronometer, press the "LAP" push button (6) and, within seven seconds, the push button **D**.
- ◆ To start timing, press the "LAP" push button (6) and release it immediately.
- ◆ To store the time acquired, press the "LAP" push button (6).

The "LAP" push button (6) is not enabled for 10 seconds and the last time stored (23) is shown on the display. After which, the chronometer with the current timing (24) is displayed, starting from ten seconds.

- ◆ To display the first time stored (25), press the push button **B**.
- ◆ To be able to see the stored times in sequence, press the "LAP" push button (6). The writings L 1, L 2, L 3, L 4, etc. (26) are displayed.
- ◆ To start timing again, press the push button **B**.

NOTE It is possible to store max. forty times, after which the "LAP" push button (6) is not effective any longer.

- ◆ To set the memory to zero, press the push button **A** and the "LAP" push button (6) at the same time for two seconds.
- ◆ To leave the chronometer function, press the "LAP" push button (6) and the push button **D**.

The coolant temperature (8) and the digital clock (7) appear on the right display (multifunction).

NOTE When the engine is cold, the writing "cold" blinks.

2.3.12 DIAGNOSTICS

Whenever the ignition switch is turned to position "O", the writing "E F I" is displayed for about three seconds.

CAUTION

If the writing "E F I" is displayed during the normal operation of the engine, this means that the electronic unit has detected an anomaly.

In many cases, the engine keeps running with reduced performance levels, see 6.4 (IGNITION SYSTEM).

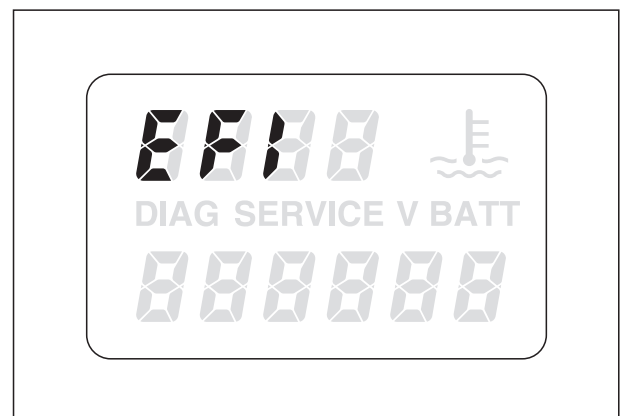
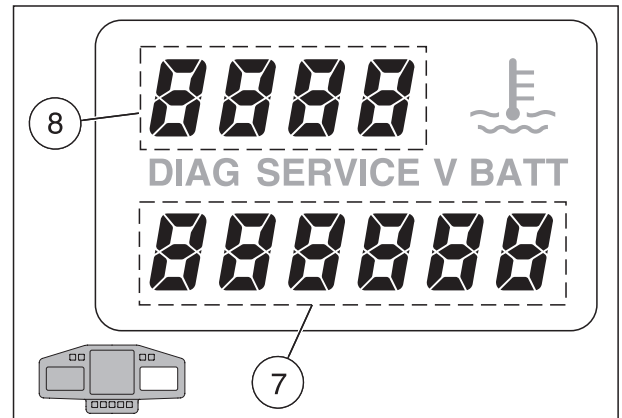
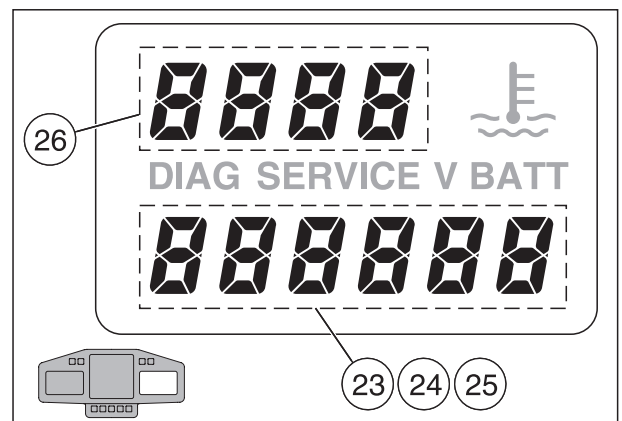
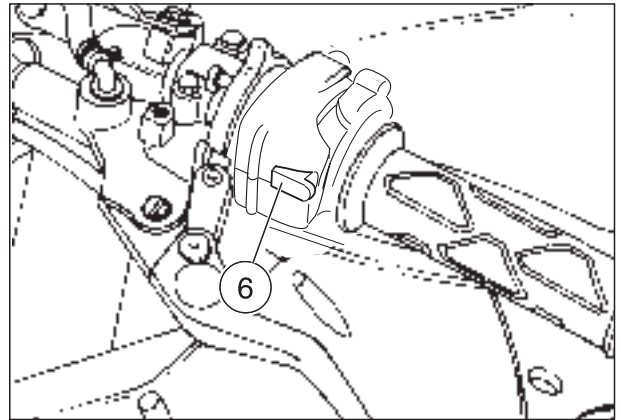

2.4 BATTERY

Carefully read 0.5.1 (PRECAUTIONS AND GENERAL INFORMATIONS).

There are two kinds of commercially available batteries:

- batteries requiring **maintenance** featuring cell plugs;
- **maintenance-free** batteries with no cell plugs as they **do not call** for the electrolyte level to be checked and topped up.

NOTE This vehicle is provided with a maintenance-free battery and no operation is necessary, excepting occasional checks and the recharge when required.

When changing batteries, replace with a battery of the same type.

For further information, see 6.11 (BATTERY).

⚠ CAUTION

Never invert the connection of the battery cables. Connect and disconnect the battery with the ignition switch in position "⊗", otherwise some components may be damaged.

Connect first the positive cable (+) and then the negative cable (-).

Disconnect following the reverse order.

NOTE Check battery voltage with a portable tester. If voltage is less than 12V, the battery must be recharged. If the voltage drops below 8V, the electronic unit is not working and is preventing engine operation.

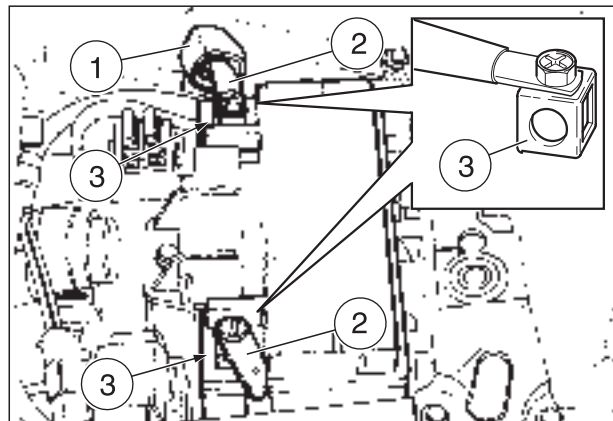

2.4.1 CHECKING AND CLEANING THE TERMINALS

Carefully read 2.4 (BATTERY).

Battery terminal tightening:

for the maintenance intervals, see 2.1.1 (REGULAR SERVICE INTERVALS CHART).

- ◆ Make sure that the ignition switch is in position "⊗".
- ◆ Put back the rider saddle, see 7.1.1 (REMOVING THE RIDER SADDLE).
- ◆ Remove the red protection element (1).
- ◆ Make sure that the cable terminals (2) and the battery terminals (3) are:
 - in good conditions (and not corroded or covered with deposits);
 - covered with neutral grease or vaseline.

If necessary, proceed as follows:

- ◆ Remove the battery, see 7.1.8 (REMOVING THE BATTERY).
- ◆ Brush the cable terminals (2) and the battery terminals (3) with a wire brush, in order to eliminate any trace of corrosion.
- ◆ Install the battery.

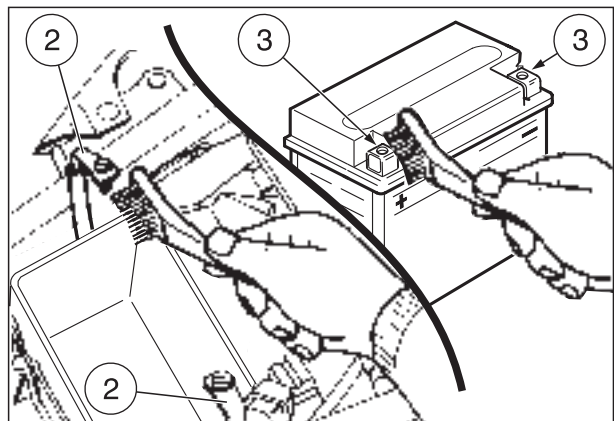

2.4.2 RECHARGING THE BATTERY

Carefully read 2.4 (BATTERY).

NOTE If the start relay emits a vibration-type noise when the start pushbutton is pressed “

NOTE Do not remove the battery plugs: without plugs the battery may be damaged.

- ◆ Remove the battery, see 7.1.8 (REMOVING THE BATTERY).
- ◆ Prepare an appropriate battery charger.
- ◆ Set the charger for the desired type of recharge (see table).
- ◆ Connect the battery to a battery charger.

WARNING

During the recharging, make sure that the room is properly ventilated.

- ◆ Switch on the battery charger.

Type of recharge	Volt (V)	Ampère (A)	Time (hours)
Normal	12	1.2	8 - 10
Quick	12	12	0.5

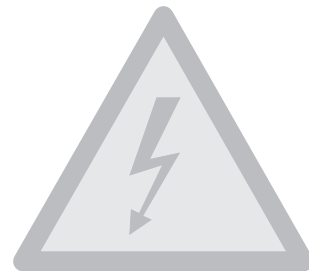
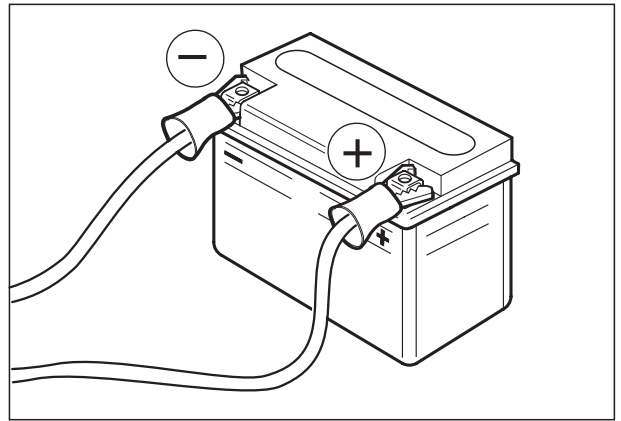

2.4.3 LONG INACTIVITY OF THE BATTERY

Carefully read 2.4 (BATTERY).

CAUTION

If the vehicle remains unused for more than twenty days, disconnect the 30A fuses, in order to avoid the deterioration of the battery caused by the current consumption due to the multifunction computer.

The removal of the 30 A fuses requires the setting to zero of the following functions: digital clock and red line setting.

To reset these functions, see 2.3 (MULTIFUNCTION COMPUTER).

If the vehicle remains unused for more than fifteen days, it is necessary to recharge the battery, in order to prevent its sulphation, see 2.4.2 (RECHARGING THE BATTERY):

- ◆ Remove the battery, see 7.1.8 (REMOVING THE BATTERY) and put it in a cool and dry place.

It is important to check the charge periodically (about once a month), during the winter or when the vehicle remains unused, in order to prevent the deterioration of the battery.

- ◆ Recharge it completely with a normal charge, see 2.4.2 (RECHARGING THE BATTERY).

If the battery remains on the vehicle, disconnect the cables from the terminals.

2.5 ELECTRIC COMPONENTS

Carefully read 0.5.1 (PRECAUTIONS AND GENERAL INFORMATIONS).

Light operation/direction, light system, safety switches:

for the maintenance intervals, see 2.1.1 (REGULAR SERVICE INTERVALS CHART).

For the check, proceed as follows:

- ◆ Position the vehicle on the stand.
- ◆ Check all the lighting devices are working.
- ◆ Check the direction of the headlight beam is correct, see 6.13 (ADJUSTING THE VERTICAL HEADLIGHT BEAM) and 6.14 (ADJUSTING THE HORIZONTAL HEADLIGHT BEAM .
- ◆ Make sure all connectors are inserted properly.
- ◆ Make sure all switches are correctly fastened and in proper working order, see:
 - 6.6.4 (CHECKING THE SIDE STAND AND THE SAFETY SWITCH).
 - 6.16 (CHECKING THE SWITCHES).
- ◆ Make sure the air sensor and speedometer sensor are correctly fastened and in proper working order.

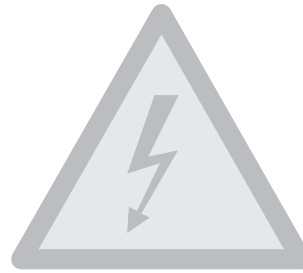

CAUTION

The sensitive area on the sensors must be kept clean at all times. Any mud, dirt etc. on them is liable to alter the measurements and the subsequent data transfer.

2.6 JUMP-STARTING

Carefully read 2.4 (BATTERY).

⚠ WARNING

The vehicle should only be jump-started when the vehicle's battery is partially/completely flat and recharging is not possible.

Do not attempt to start the vehicle by pushing or towing it.

The vehicle providing assistance must have a battery (the recharge source) with exactly the same rated voltage (data to be found on the battery) as the battery of the vehicle to be started, see 1.5 (TECHNICAL SPECIFICATIONS).

Follow the procedure below to the letter so as to avoid the danger of the battery exploding and possibly injuring people and/or property (this is liable to compromise the electric components of both vehicles).

- ◆ Prepare the auxiliary vehicle, in such a way as to have access to the battery of the same.
- ◆ Make sure that the ignition switch is in position "⊗".
- ◆ Put back the rider saddle, see 7.1.1 (REMOVING THE RIDER SADDLE).

NOTE Leave the battery cables of both vehicles connected.

⚠ CAUTION

Take care never to let the clamps of one cable touch those of another.

- ◆ Remove the red protection element (1).

NOTE Always connect the positive poles (+) first, following the order indicated below.

⚠ WARNING

The jump leads must not be placed near any moving parts on either vehicle.

- ◆ Connect one end of jump lead to the positive pole (+) of the battery on the vehicle providing assistance (A); and the other end on the positive pole (+) of the battery on the vehicle to be started (B).
- ◆ Connect one end of the other jump lead to the negative pole (-) of the battery on the vehicle providing assistance (A); and earth the other end on the frame (far from the battery) of the vehicle to be started (B).

DO NOT CONNECT TO THE NEGATIVE POLE (-).

- ◆ Start the engine of the auxiliary vehicle.

NOTE During the starting phase, the engine of the auxiliary vehicle must keep running.

- ◆ Proceed to the starting of the broken-down vehicle.

NOTE Attempt to start the vehicle for no more than ten seconds at a time, where necessary, repeating the attempt at intervals of approx. one minute.

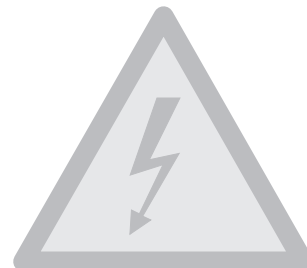
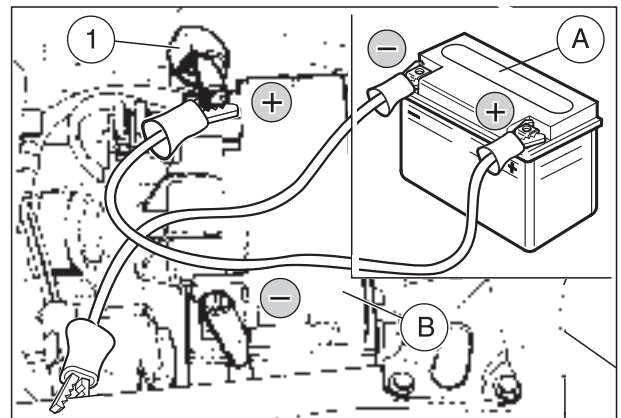
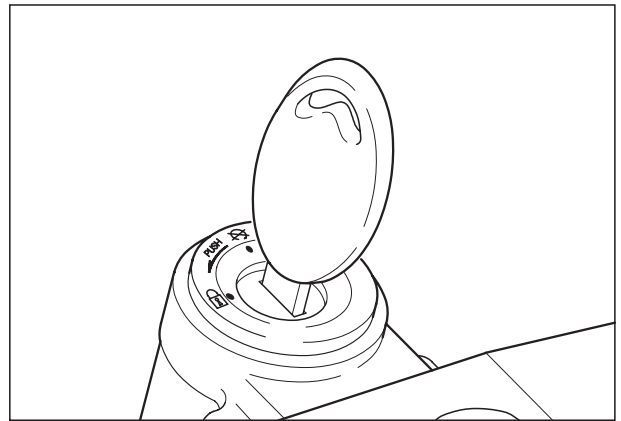

NOTE Once started, keep both engines running for approx. two minutes.

- ◆ Stop both engines.
- ◆ Disconnect the negative booster cable (-) from both batteries.
- ◆ Disconnect the positive booster cable (+) from both batteries.

2.7 SPARK PLUGS

Carefully read 0.5.1 (PRECAUTIONS AND GENERAL INFORMATIONS).

Spark plugs:

for the maintenance intervals, see 2.1.1 (REGULAR SERVICE INTERVALS CHART).

⚠ CAUTION

Check, clean or change all the spark plugs, one by one.

Even if only one spark plug needs changing, always replace all of them.

NOTE The vehicle is equipped with two spark plugs per cylinder (A) and (B).

The following operations refer to one spark plug only, but are valid for both.

To reach the spark plugs:

⚠ CAUTION

Let the engine cool down until it reaches room temperature.

Never disconnect the spark plug cap with the engine running, since you may get an electric shock from the ignition system.

- ◆ Lift the fuel tank, see 2.8 (LIFTING THE FUEL TANK).

For the removal, proceed as follows:

⚠ CAUTION

Do not invert the position of the two spark plug caps. Do not remove the two spark plug caps at the same time.

- ◆ Remove the cap (1) of the spark plug (2).
- ◆ Remove any trace of dirt from the spark plug base.
- ◆ Introduce the special spanner provided in the tool kit on the spark plug.
- ◆ Insert the 13 mm fork spanner provided in the tool kit in the hexagonal seat of the spark plug spanner.
- ◆ Unscrew the spark plug and extract it from its seat, taking care to prevent dust or other substances from getting inside the cylinder.

For the check and cleaning:

⚠ CAUTION

This vehicle is fitted with spark plugs featuring platinum-type electrodes.

To clean the spark plugs, do not use wire brushes and/or abrasive products, but only a pressurized air jet.

- centre electrode (3);
- insulating (4);
- side electrode (5).

- ◆ Make sure that there are neither carbon deposits, nor corrosion marks on the electrodes and on the insulating material; if necessary, clean them with a pressurized air jet.

If the spark plug has crackings on the insulating material, corroded electrodes, excessive deposits or the tip (6) of the central electrode (3) is rounded, it must be changed.

Follow ►

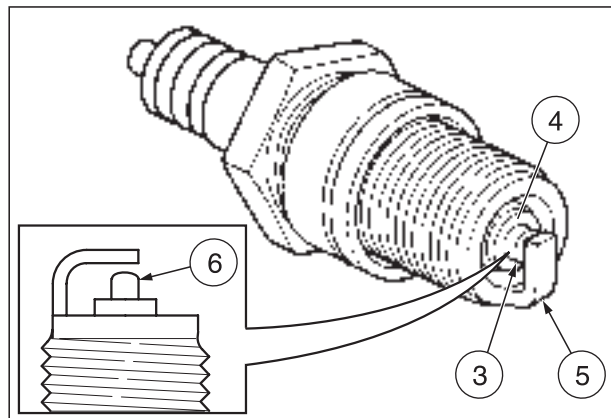
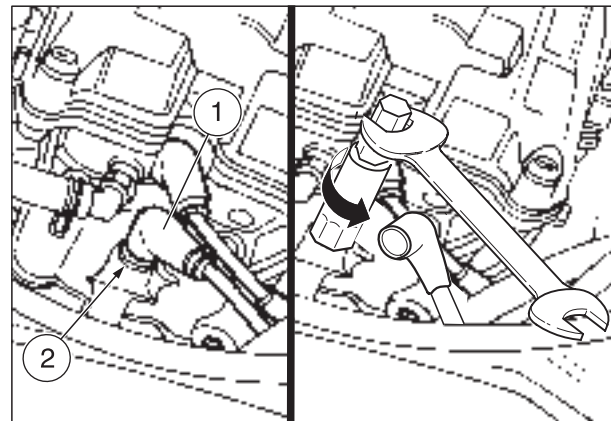
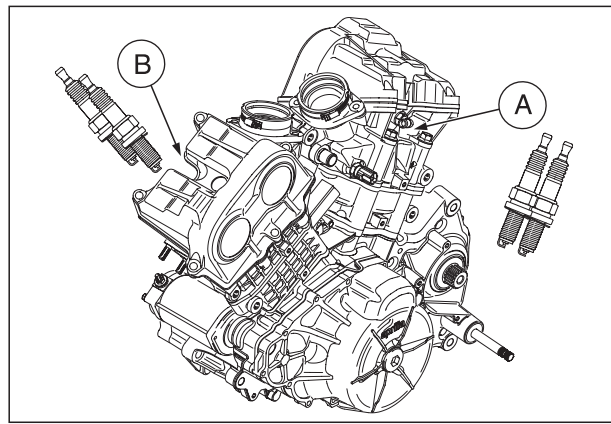

Follow ►

⚠ CAUTION

When changing the spark plug, check the thread pitch and length.

If the threaded part is too short, the carbon deposits will accumulate on the thread seat, and therefore the engine may be damaged during the installation of the right spark plug.

Use the recommended type of spark plugs only, see 1.5 (TECHNICAL SPECIFICATIONS), in order not to compromise the life and performance of the engine.

⚠ CAUTION

To check the spark plug gap, use a wire thickness gauge (7) to avoid damaging the platinum covering.

◆ Check the spark plug gap with a wire thickness gauge (7).

⚠ CAUTION

Do not try to recover the spark plug gap in any way.

The gap must be 0.6 – 0.7 mm, otherwise it is necessary to change the spark plug.

◆ Make sure that the washer (8) is in good conditions.

For the installation:

- ◆ With the washer on (8), screw the spark plug by hand in order not to damage the thread.
- ◆ Tighten the spark plug by means of the spanner you will find in the tool kit, giving it half a turn to compress the washer.

Spark plug driving torque: 20 Nm (2 kgm).

⚠ CAUTION

The spark plug must be well tightened, otherwise the engine may overheat and be seriously damaged.

◆ Position the spark plug cap (1) properly, so that it does not come off due to the vibrations of the engine.

NOTE Repeat the operations described on the second spark plug of the same cylinder and successively on both spark plugs of the other cylinder.

Put back the fuel tank, see 2.8 (LIFTING THE FUEL TANK).

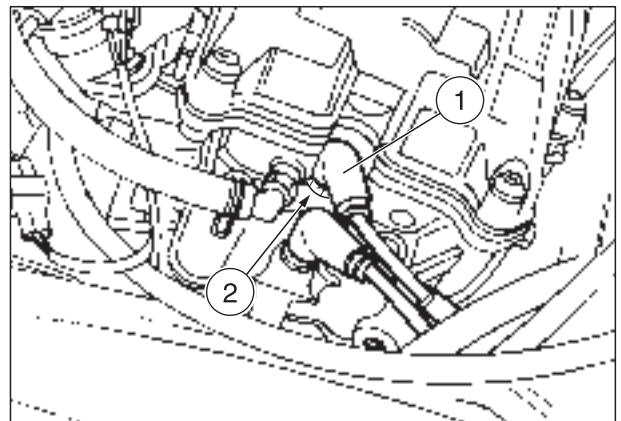
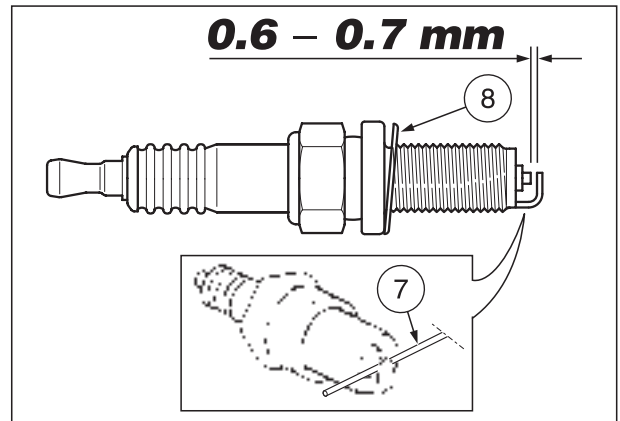

2.8 LIFTING THE FUEL TANK

Carefully read 1.2.1 (FUEL).

⚠ WARNING

Risk of fire.

Wait until the engine and the exhaust silencer have completely cooled down.

- ◆ Remove the passenger seat, see 7.1.2 (UNLOCKING/ LOCKING THE PASSENGER SEAT).
- ◆ Put back the rider saddle, see 7.1.1 (REMOVING THE RIDER SADDLE).
- ◆ Unscrew and remove the two screws (1) that fasten the front part of the fuel tank (2).
- ◆ Remove the fuel tank support rod (5) from the relevant anchorage seats (3) (4).

NOTE The rubber-covered end of the rod (5) must be introduced in the central hole of the steering pin.

- ◆ Lift the front part of the fuel tank (2) and introduce the rod (5) as indicated in the figure.

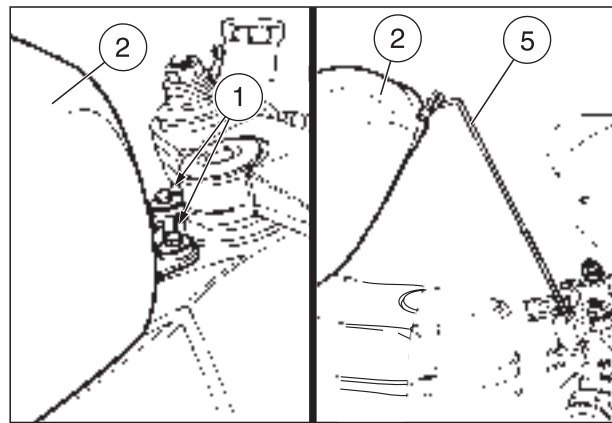

2.9 DRAINING THE FUEL TANK

Carefully read 1.2.1 (FUEL).

Fuel pipes:

for the maintenance intervals, see 2.1.1 (REGULAR SERVICE INTERVALS CHART).

⚠ WARNING

Risk of fire.

Wait until the engine and exhaust silencer have completely cooled down.

Fuel vapours are noxious for your health.

Before proceeding, make sure that the room in which you are working is properly ventilated.

Do not inhale fuel vapours.

Do not smoke and do not use naked flames.

Do not dispose of fuel in the environment.

- ◆ Stop the engine and wait until it has cooled down.
- ◆ Lift the fuel tank, see 2.8 (LIFTING THE FUEL TANK).
- ◆ Prepare a container with capacity exceeding the fuel quantity present in the tank and put it on the ground on the left side of the vehicle.

NOTE Place a cloth under the male quick-release coupling (1) to catch any fuel spills.

- ◆ Disconnect the male quick-release coupling (6) from the receptacle (7) by pressing the relevant button.

Follow ►

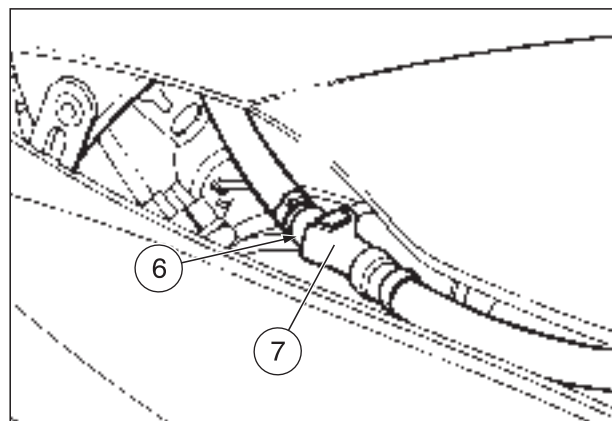
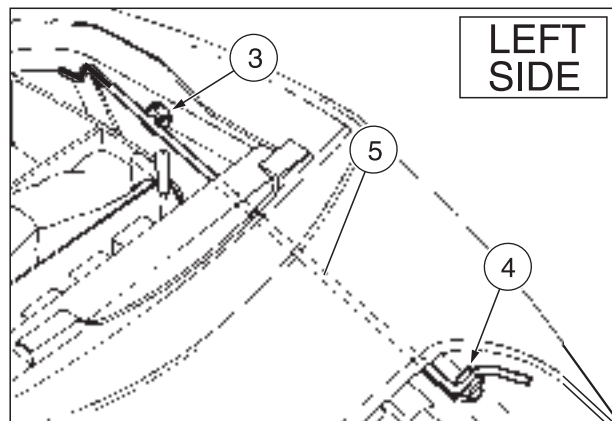

Follow ►

NOTE Have the appropriate special tool **OPT** to hand:
– aprilia part# 0277295 (hose clamp installation pliers).

⚠ CAUTION

Upon installation, replace the hose clamp that has been removed with a new one having the same dimensions, see 0.4.2 (SPARE PARTS CATALOGUES).

Do not attempt to reinstall the removed hose clamp, since it is unusable.

Do not replace the removed hose clamp with a screw clamp (8) or with other types of clamp.

- ◆ Release the hose clamp (9).
- ◆ Disconnect the pipe (10).
- ◆ Place the free end of the pipe (10) inside the container prepared beforehand.
- ◆ Insert the male quick-release coupling (6) of the pipe (10) all the way into the quick-release receptacle (7). The petrol starts draining out immediately.
- ◆ Open the tank cap.
- ◆ Wait until all the petrol has drained out of the tank.

Once all the petrol has drained out:

- ◆ Connect the pipe (10) and install a new hose clamp.
- ◆ Insert the male quick-release coupling (6) into the receptacle (7).

NOTE Make sure the male quick coupling (6) has been correctly inserted into the receptacle (7).

- ◆ Put back the fuel tank.
- ◆ Close the tank cap again.

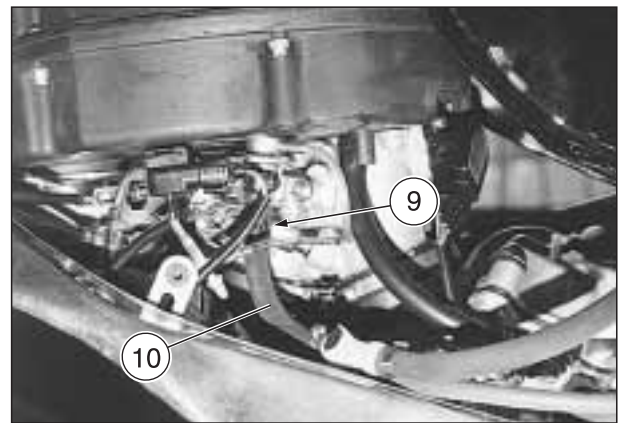
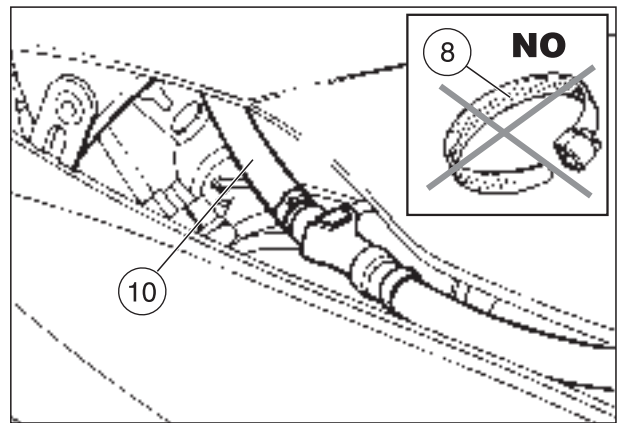

2.10 AIR CLEANER

Carefully read 0.5.1 (PRECAUTIONS AND GENERAL INFORMATIONS).

Air cleaner:

for the maintenance intervals, see 2.1.1 (REGULAR SERVICE INTERVALS CHART).

⚠ CAUTION

The partial cleaning of the filter does not exclude or postpone the replacement of the filter itself.

Do not start the engine if the air cleaner has been removed.

Do not clean the filtering element with petrol or solvents, since they may cause a fire in the fuel supply system, with serious danger for the persons in the vicinity and for the vehicle.

DO NOT DISPOSE OF POLLUTING SUBSTANCES OR COMPONENTS IN THE ENVIRONMENT.

- ◆ On each maintenance operation, remove the small plug (1), drain the contents into a container and then deliver it to a salvage center.

REMOVAL

- ◆ Lift the fuel tank, see 2.8 (LIFTING THE FUEL TANK).
- ◆ Unscrew and remove the seven screws (2) that fasten the filter case cover (3).
- ◆ Remove the filter case cover (3).
- ◆ Extract the air cleaner (4).
- ◆ Check the conditions of the gasket (5) and change it if it is damaged.

⚠ CAUTION

Plug the opening with a clean cloth, in order to prevent any foreign matter to get it.

PARTIAL CLEANING

⚠ CAUTION

Do not press or strike the metal net of the air cleaner (4).

Do not use screwdrivers or alike.

- ◆ Seize the air cleaner (4) vertically and strike it more than once on a clean surface.
- ◆ If necessary, clean the air cleaner (4) with a compressed air jet (directing it from the inside towards the outside of the filter).

⚠ CAUTION

When cleaning the filtering element, make sure that there are no tears.

Otherwise, change the filtering element.

- ◆ Clean the outer part of the air cleaner (4) with a clean cloth.

CHANGING

- ◆ Replace the air cleaner (4) with a new one of the same type.

⚠ CAUTION

Do not use filters that have already been used.

Make sure that the filtering element is positioned correctly, in such a way as to prevent non-filtered air from entering.

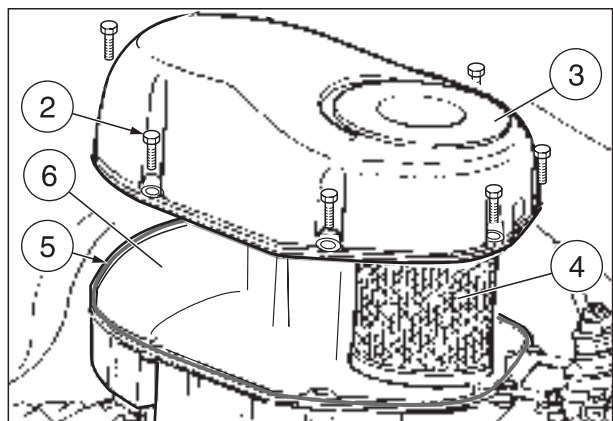
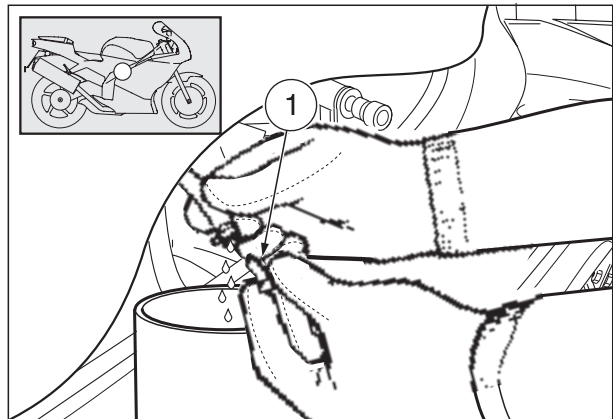
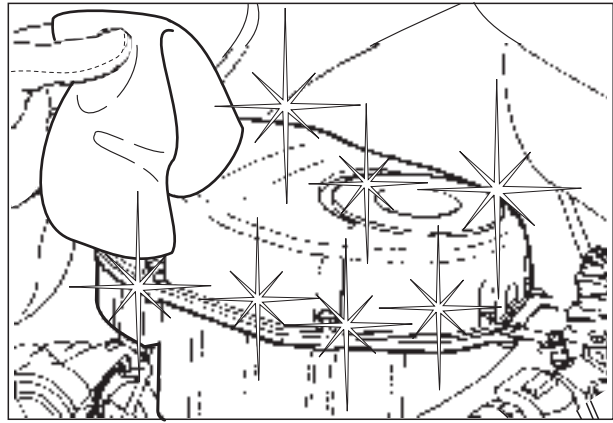

⚠ CAUTION

Remember that the untimely wear of the piston segments and the cylinder may be caused by a faulty or incorrectly positioned filtering element.

If the vehicle is used in dusty areas, clean the filtering element more frequently.

Using the vehicle without the filtering element, or with the element damaged, considerably increases wear and tear on the engine.

Make sure the filtering element is always in perfect condition. The life of the engine depends, for the most part, on this component.

2.11 ACCELERATOR

2.11.1 CHECKING THE OPERATION OF THE ACCELERATOR CONTROL

Transmission cables and controls:

for the maintenance intervals, see 2.1.1 (REGULAR SERVICE INTERVALS CHART).

For the check, proceed as follows:

⚠ WARNING

The use of the vehicle with damaged, excessively bent or twisted accelerator cable may hinder the regular operation of the accelerator and make you lose control of the vehicle while riding.

Make sure that the rotation of the handlebar does not modify the engine idle speed and that the throttle grip returns smoothly and automatically to its original position after being released.

If necessary, proceed as follows:

NOTE For the lubrication of the components use the specific lubricant available on the market.

- ◆ Check the correct position and the lubrication of the following components:
 - sheath;
 - throttle grip adjuster (1);
 - throttle body adjuster (2);
 - throttle body pin (3);
 - cable couplings (ends);
 - accelerator control.
- ◆ Check the idle speed, 2.11.2 (IDLING ADJUSTMENT).
- ◆ Check the accelerator control adjustment, 2.11.3 (ADJUSTING THE ACCELERATOR CONTROL).

2.11.2 IDLING ADJUSTMENT

(*) = up to frame # ZD4MEE009YS000292

(**) = as of frame # ZD4MEE009YS000293

Engine idling rpm:

for the maintenance intervals, see 2.1.1 (REGULAR SERVICE INTERVALS CHART).

To carry out this operation, proceed as follows:

- ◆ Ride for a few miles until reaching the normal running temperature.
- ◆ Position the gear lever in neutral (green warning light "N" on).
- ◆ Check the engine idling rpm on the revolution counter. The engine idling speed must be about 1250 ± 100 rpm.

If necessary, proceed as follows:

- ◆ Position the vehicle on the stand.
- ◆ (*) Introduce a small cut-headed screwdriver in the appropriate hole provided on the right side cover and turn the adjusting knob (4).
 - When the screw is turned clockwise, the rpm increases.
 - When the screw is turned anticlockwise, the rpm decreases.

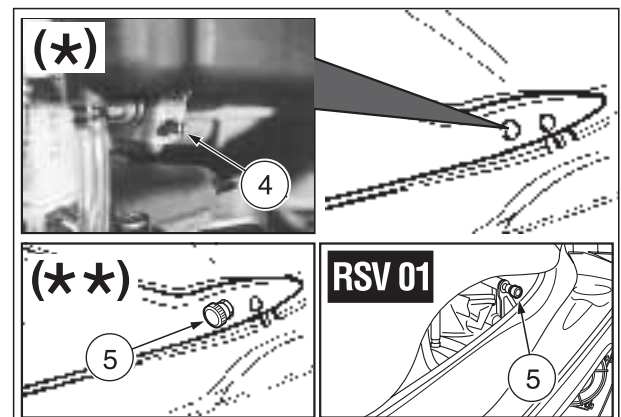
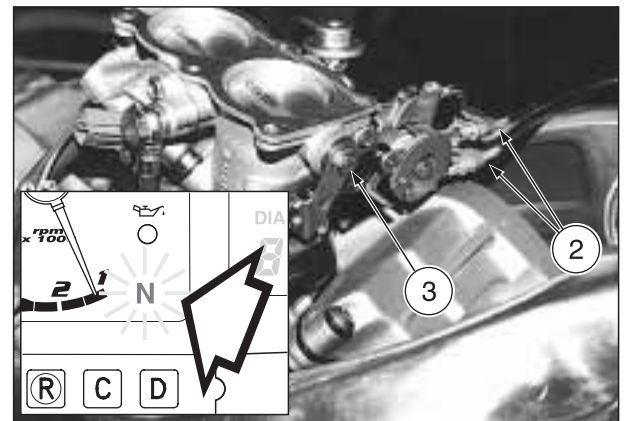
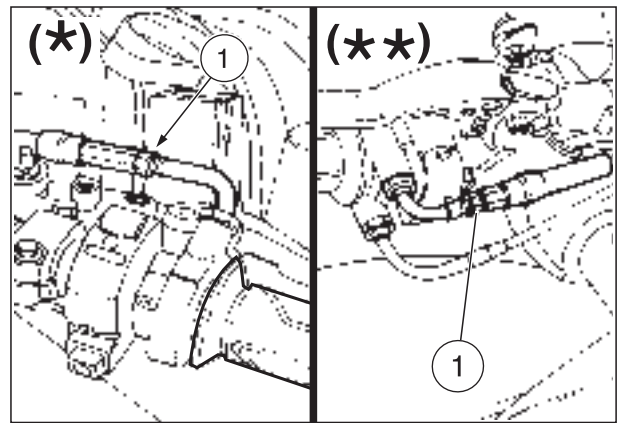

- ◆ (**) **RSV 01** Turn the adjusting knob (5) provided on the right side of the vehicle.
 - When the knob is turned clockwise, the rpm increases;
 - When the knob is turned anticlockwise, the rpm decreases.
- ◆ Twist the throttle grip, accelerating and decelerating a few times to make sure that it functions correctly and to check if the idling speed is constant.

For further information, see section 4 (FUEL SUPPLY SYSTEM).

2.11.3 ADJUSTING THE ACCELERATOR CONTROL

Accelerator cables (adjustments):

for the maintenance intervals, see 2.1.1 (REGULAR SERVICE INTERVALS CHART).

For the check, proceed as follows:

(*) = up to frame # ZD4MEE009YS000292

(**) = as of frame # ZD4MEE009YS000293

The idle stroke of the throttle grip must be 2 – 3 mm, measured on the edge of the grip itself.

If not, proceed as follows:

- ◆ Position the vehicle on the stand.
- ◆ Withdraw the protection element (6).
- ◆ Loosen the lock nut (7).
- ◆ Rotate the adjuster (8) in such a way as to restore the prescribed value.
- ◆ After the adjustment, tighten the lock nut (7) and check the idle stroke again.
- ◆ Put back the protection element (6).

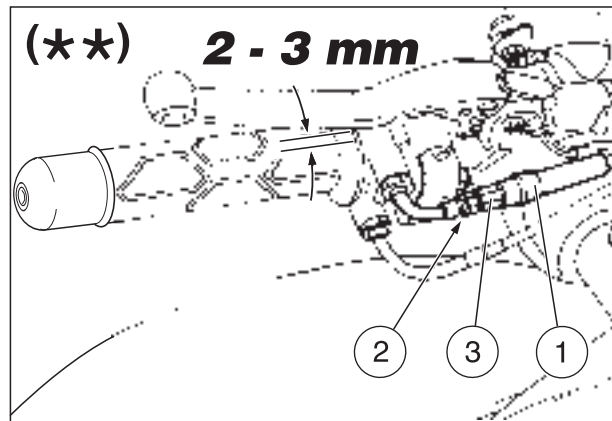
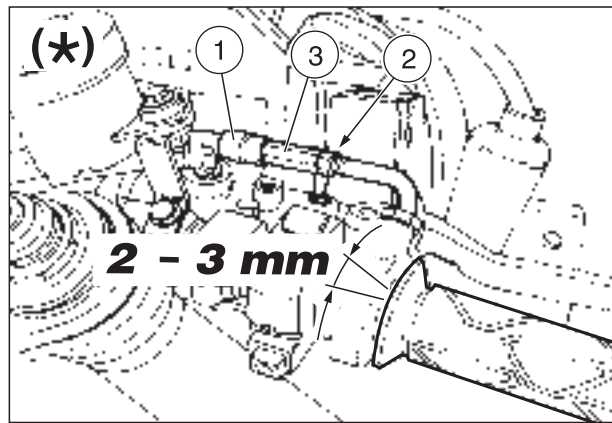

CAUTION
 After the adjustment, make sure that the rotation of the handlebar does not modify the engine idling rpm and that the throttle grip returns smoothly and automatically to its original position after being released.

2.12 COLD START CABLE

The cold start cable must be adjusted so that the hand lever (9) has 2 – 3 mm of freeplay.

If not, proceed as follows:

- ◆ Position the vehicle on the stand.
- ◆ Lift the fuel tank, see 2.8 (LIFTING THE FUEL TANK).
- ◆ Loosen the lock nut (10).
- ◆ Rotate the adjuster (11) in such a way as to restore the prescribed value.
- ◆ After the adjustment, tighten the lock nut (10) and check the idle stroke again.

CAUTION
 Once the adjustment has been made, check that the rotation of the handlebar does not influence the engine rpm.

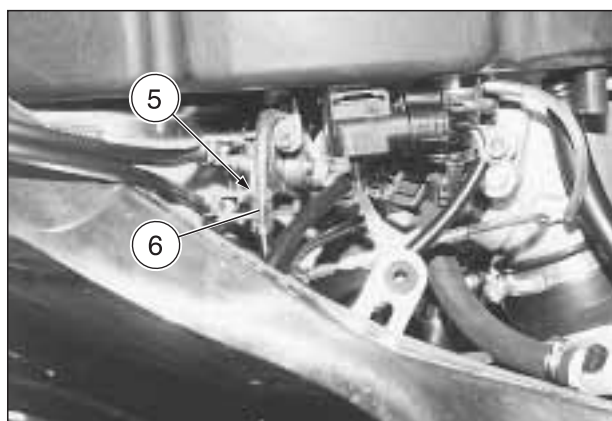
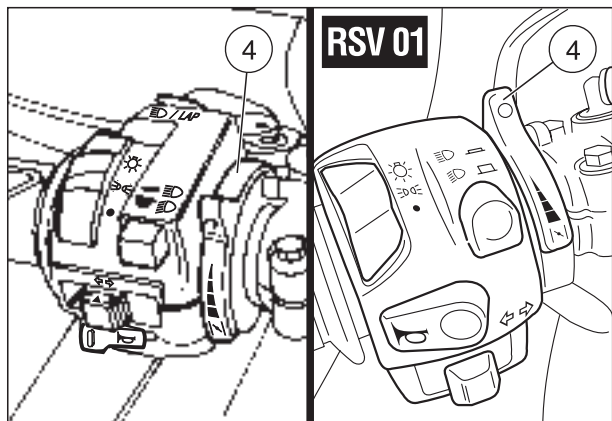

2.13 CHECKING THE ENGINE OIL LEVEL AND TOPPING UP

Carefully read 0.5.1 (PRECAUTIONS AND GENERAL INFORMATIONS) and 1.2.2 (ENGINE OIL).

Engine oil, engine oil pressure warning light LED:

for the maintenance intervals, see 2.1.1 (REGULAR SERVICE INTERVALS CHART).

For the check, proceed as follows:

NOTE Position the vehicle on the side stand on firm and level ground.

⚠ CAUTION

The engine oil level must be checked with warm engine.

If the check is carried out with cold engine, the oil level may temporarily lower below the "MIN" mark.

This is not a problem, provided that the engine oil pressure warning light LED "⚠" (A) does not come on.

- ◆ Start the engine.
- ◆ Allow the engine to idle for about 15-20 minutes, or ride the vehicle on a country road for approximately 15 km (9.5 mi).
- ◆ Stop the engine.
- ◆ Keep the vehicle in vertical position, with the two wheels resting on the ground.
- ◆ Check the oil level in the transparent pipe (1) through the appropriate slot provided on the left fairing.

MAX = maximum level

MIN = minimum level.

The difference between "MAX" and "MIN" amounts to approximately 500 cm³.

- ◆ The level is correct when the oil almost reaches the "MAX" mark.

If necessary, top up the engine oil by proceeding as follows:

- ◆ Remove the left fairing, see 7.1.28 (REMOVING THE SIDE FAIRINGS).
- ◆ Unscrew and remove the filling cap (2).

⚠ CAUTION

Never exceed the "MAX" mark, nor leave the oil below the "MIN" mark, in order to avoid serious damage to the engine.

Do not put additives or other substances into the oil. If you use a funnel or other similar items, make sure that they are perfectly clean.

- ◆ Top up the tank and restore the correct level, see 1.6 (LUBRICANT CHART).

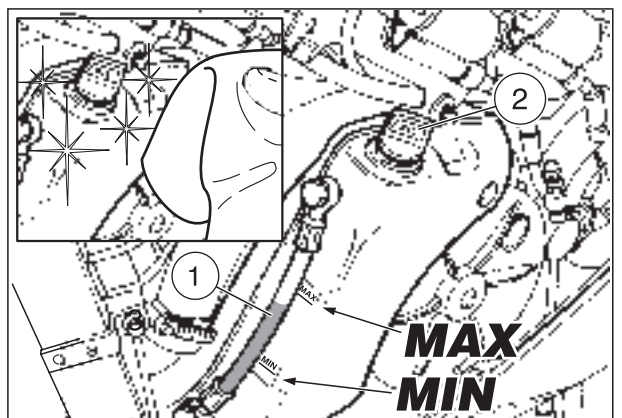
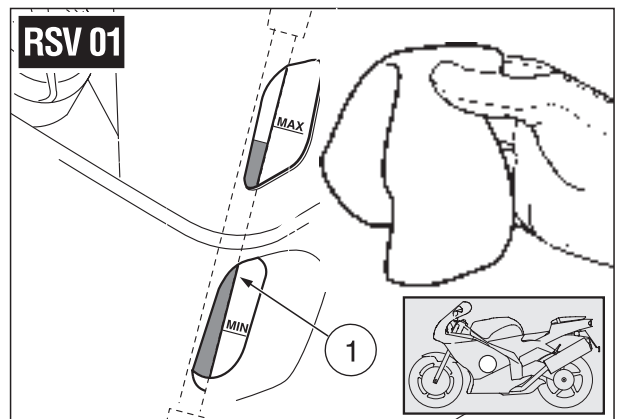
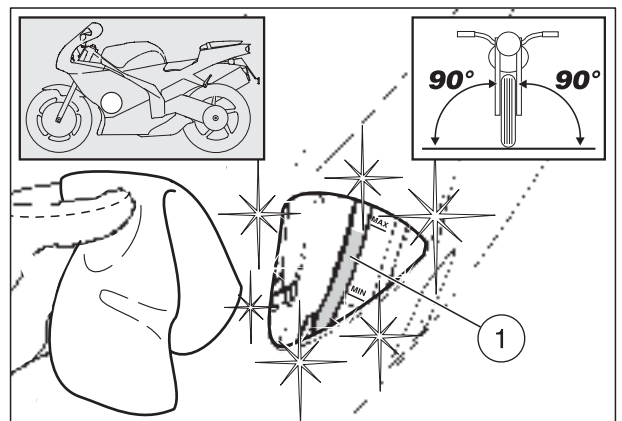
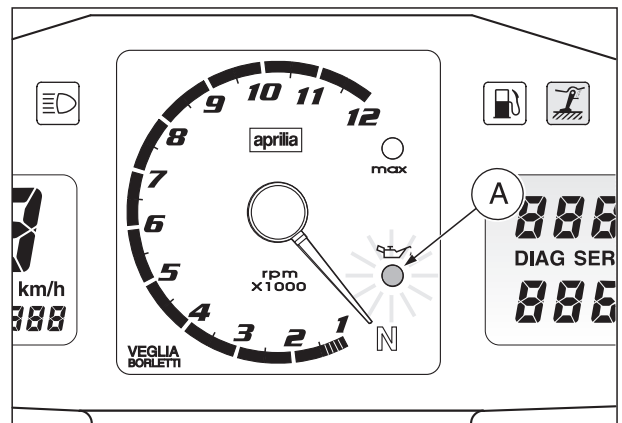

2.14 CHANGING THE ENGINE OIL AND THE OIL FILTER

Carefully read 0.5.1 (PRECAUTIONS AND GENERAL INFORMATIONS) and 1.2.2 (ENGINE OIL).

Motor oil:

for the maintenance intervals, see 2.1.1 (REGULAR SERVICE INTERVALS CHART).

ENGINE OIL DRAIN

NOTE The oil flows out completely and without problems when it is warm and therefore more fluid: to achieve this condition, the engine should run for approximately twenty minutes.

⚠ WARNING

When warmed up, the engine contains hot oil; therefore, while carrying out the operations described here below be particularly careful, in order to avoid burns.

NOTE Position the vehicle on the side stand on firm and level ground.

- ◆ Remove the lower fairing, see 7.1.34 (REMOVING THE LOWER FAIRING).
- ◆ Position a container (1) with more than 4000 cm³ capacity in correspondence with the drain plug (2) positioned on the tank.
- ◆ Unscrew and remove the drain plug (2) positioned on the tank.
- ◆ Unscrew and remove the filling cap (3).
- ◆ Drain the oil and let it drip into the container (1) for a few minutes.
- ◆ Check and if necessary replace the sealing washer of the drain plug (2) positioned on the tank.
- ◆ Screw and tighten the drain plug (2) on the tank.

Drain plug (2) driving torque: 15 Nm (1.5 kgm).

- ◆ Move the container (1) and position it under the engine base, in correspondence with the drain plug positioned on the engine (4).
- ◆ Unscrew and remove the drain plug positioned on the engine (4).
- ◆ Drain the oil and let it drip into the container (1) for a few minutes.

⚠ CAUTION

Do not dispose of the oil in the environment. Deliver it to or have it collected by the nearest oil salvage center or by the supplier.

- ◆ Remove the metal residues from the drain plug (4) magnet.
- ◆ Screw and tighten the drain plug (4).

Drain plug (4) positioned on the engine driving torque: 12 Nm (1.2 kgm).

Follow ►

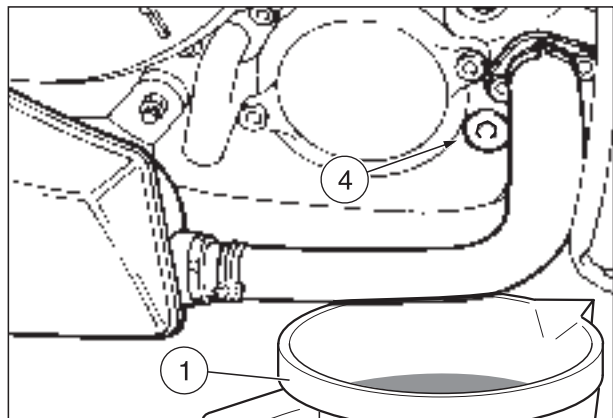
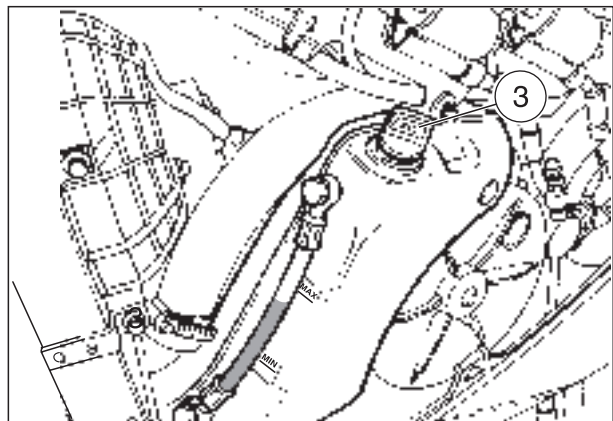
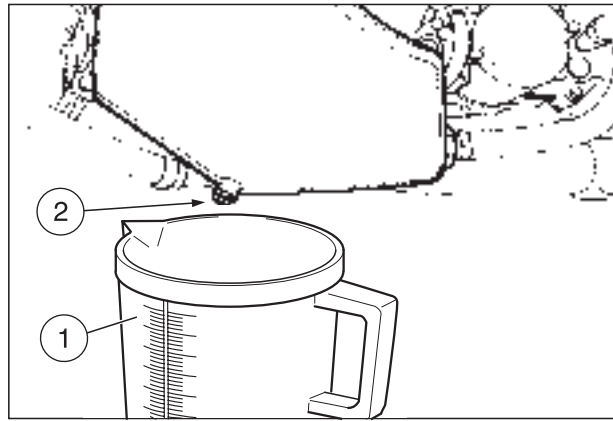

Follow ►

CHANGING THE ENGINE OIL FILTER**Engine oil filter:**

for the maintenance intervals, see 2.1.1 (REGULAR SERVICE INTERVALS CHART).

- ◆ Unscrew the two screws (5) and remove the cover (6).
- ◆ Remove the engine oil filter (7).

⚠ CAUTION

Do not use filters that have already been used.

- ◆ Spread an oil film on the sealing ring (8) of the new engine oil filter.
- ◆ Fit the new engine oil filter.
- ◆ Put back the cover (6), screw and tighten the two screws (5).

Screws (5) driving torque: 11 Nm (1.1 kgm).

CLEANING THE ENGINE OIL FILTER ON THE TANK**Engine oil filter (on oil tank):**

for the maintenance intervals, see 2.1.1 (REGULAR SERVICE INTERVALS CHART).

NOTE Have the appropriate special tool **OPT** to hand:
– **aprilia** part# 0277295 (hose clamp installation pliers).

⚠ CAUTION

Upon installation, replace the hose clamp that has been removed with a new one having the same dimensions, see 0.4.2 (SPARE PARTS CATALOGUES).

Do not attempt to reinstall the removed hose clamp, since it is unusable.

Do not replace the removed hose clamp with a screw clamp (9) or with other types of clamp.

- ◆ Release the hose clamp (10).
- ◆ Disconnect the pipe (12).
- ◆ Unscrew and remove the engine oil filter (11) positioned on the tank and clean it with a jet of compressed air.
- ◆ Check the engine oil filter gasket (11) on the tank, screw it on and tighten up.

Engine oil filter (11) driving torque: 30 Nm (3.0 kgm).

- ◆ Connect the pipe (12) and install a new hose clamp.

⚠ CAUTION

Do not put additives or other substances into the oil. If you use a funnel or other similar items, make sure that they are perfectly clean.

CHANGING THE ENGINE OIL

- ◆ Pour about 3500 cm³ of engine oil through the filling opening (13), see 1.6 (LUBRICANT CHART).
- ◆ Tighten the filling cap (3).
- ◆ Start the engine and let it idle for about one minute, in order to ensure the filling up of the engine oil circuit.
- ◆ Check the oil level and top up if necessary, see 2.13 (CHECKING THE ENGINE OIL LEVEL AND TOPPING UP).

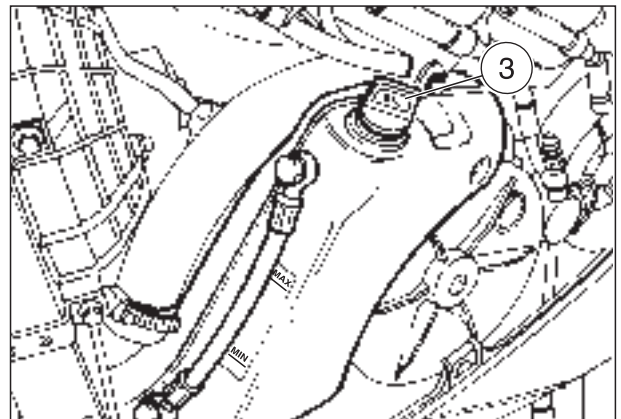
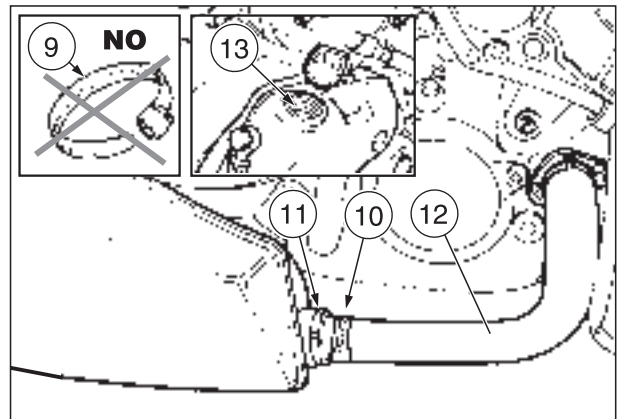
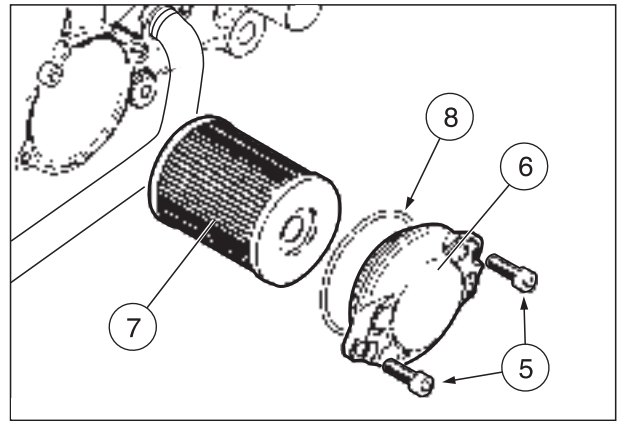

2.15 CHECKING AND TOPPING UP COOLANT

Carefully read 0.5.1 (PRECAUTIONS AND GENERAL INFORMATIONS) and 1.2.5 (COOLANT).

Coolant, cooling system:

for the maintenance intervals, see 2.1.1 (REGULAR SERVICE INTERVALS CHART).

⚠ CAUTION

Check the coolant level and top up the expansion tank with cold engine.

- ◆ Stop the engine and wait until it has cooled down.

NOTE Position the vehicle on the side stand on firm and level ground.

- ◆ Keep the vehicle in vertical position, with the two wheels resting on the ground.
- ◆ Make sure that the coolant contained in the expansion tank (1) is included between the “FULL” and “LOW” marks, by checking through the appropriate slot on the right fairing”.

If not, proceed as follows:

- ◆ Unscrew and remove the expansion tank filling cap (2).

⚠ WARNING

The coolant is noxious: do not swallow it; if the coolant gets in contact with the skin or the eyes, it can cause serious irritations.

Do not use your fingers or any other object to check if there is enough coolant.

⚠ CAUTION

Do not put additives or other substances into the fluid. If you use a funnel or other similar items, make sure that they are perfectly clean.

- ◆ Top up the expansion tank by adding coolant, see 1.6 (LUBRICANT CHART), until this almost reaches the “FULL” level.
Do not exceed this level, otherwise the fluid will flow out while the engine is running.
- ◆ Put back the expansion tank filling cap (2).

⚠ CAUTION

In case of excessive consumption of coolant and in case the tank (1) remains empty, make sure that there are no leaks in the circuit.

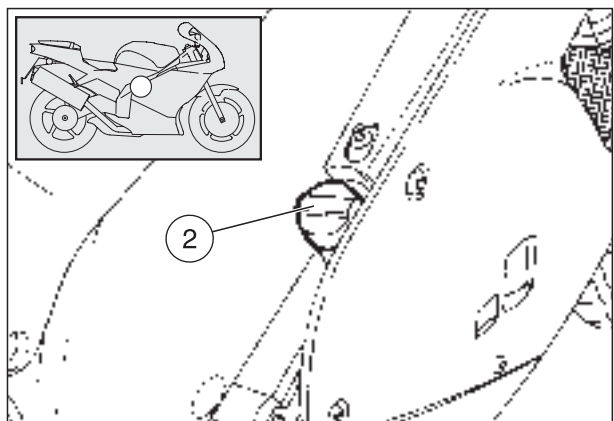
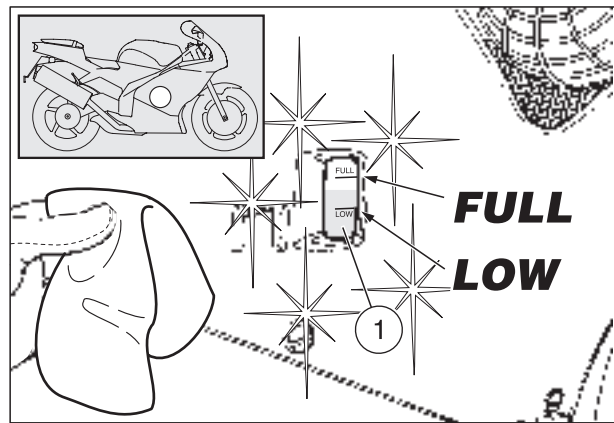

2.16 CHANGING THE COOLANT

Carefully read 0.5.1 (PRECAUTIONS AND GENERAL INFORMATIONS) and 1.2.5 (COOLANT).

Coolant, cooling system:

for the maintenance intervals, see 2.1.1 (REGULAR SERVICE INTERVALS CHART).

- ◆ Remove the upper panel of the right fairing, see 7.1.29 (REMOVING THE SIDE FAIRING UPPER PANELS).
- ◆ Remove the lower fairing, see 7.1.34 (REMOVING THE LOWER FAIRING).
- ◆ Remove the expansion tank, see 5.9 (REMOVING THE EXPANSION TANK).
- ◆ Place a container (2) under the drain screw (1) to catch the coolant (capacity over 2.5 l).
- ◆ Unscrew and remove the drain screw (1) retrieving the copper washer.

⚠ CAUTION

Do not remove the filler cap (3) when the engine is hot as the coolant is under pressure and is very hot.

- ◆ To facilitate the fluid outflow, remove the circuit filling cap (3) and successively the cap (4) positioned on the expansion tank.
- ◆ Once all the coolant has drained out, move the container (2) under the right-hand radiator.
- ◆ Unscrew and remove the drain plug (5), retrieving the aluminium washer.
- ◆ Once all the coolant has drained out, move the container under the left-hand radiator.
- ◆ Unscrew and remove the drain plug (6), retrieving the aluminium washer.

DO NOT DISPOSE OF THE FLUID IN THE ENVIRONMENT.

NOTE When reassembling, apply LOCTITE® 574 on the thread of the drain screw (1).

- ◆ Reassemble the drain screw (1) with a new copper washer.

Drain screw (1) driving torque: 12 Nm (1.2 kgm).

NOTE When reassembling, apply LOCTITE® 572 on the thread of the drain plug (5) (6).

- ◆ Reassemble the two radiator drain plugs (5) (6) with two new aluminium washers.

Drain plugs (6) (7) driving torque: 10 Nm (1.0 kgm).

Follow ►

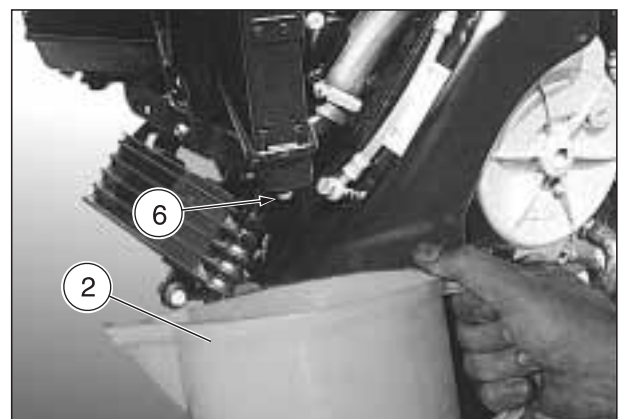
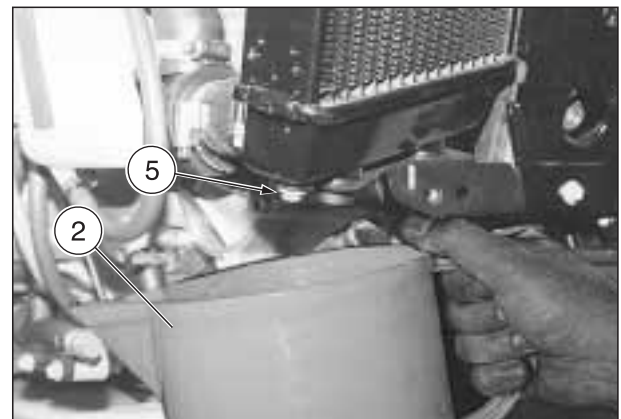
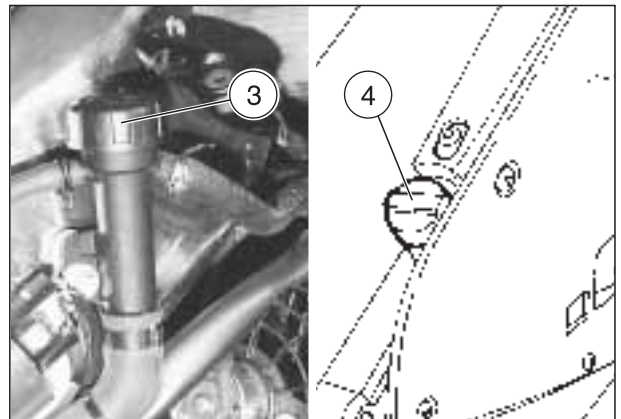
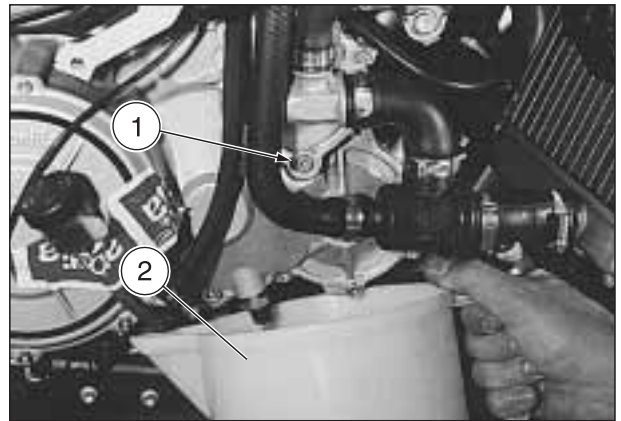

Follow ►

- ◆ Top up through the filler neck (7) until full.
- ◆ Squeeze and release the couplings (8) (9) a few times with your hands so as to create a slight pressure and enable the coolant to flow into the pipes.
- ◆ Top up again until full.

NOTE The level is correct when the coolant stabilizes immediately below the filler neck (7).

- ◆ Refit the circuit filler cap (3).
- ◆ Top up the coolant in the expansion tank, see 2.15 (CHECKING AND TOPPING UP COOLANT).
- ◆ Start the engine and let it run for a few minutes, then allow it to cool and check the level of coolant in the expansion tank again.
- ◆ If necessary, top up, see 2.15 (CHECKING AND TOPPING UP COOLANT).

Total quantity:

2.5 ℓ (including the expansion tank).

NOTE The bleeding of the system is not required for this vehicle.

For further information, see section 5 (COOLING SYSTEM).

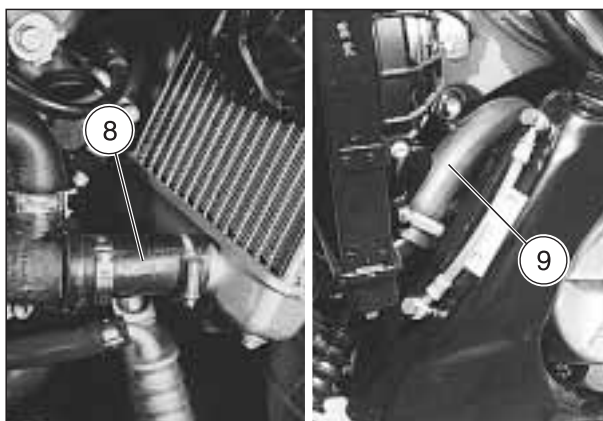

2.17 CHECKING AND TOPPING UP THE FRONT BRAKE FLUID

Carefully read 0.5.1 (PRECAUTIONS AND GENERAL INFORMATIONS) and 1.2.4 (BRAKE FLUID).

Brake fluid:

for the maintenance intervals, see 2.1.1 (REGULAR SERVICE INTERVALS CHART).

⚠ CAUTION

If the brake lever features excessive free play, if it is excessively spongy or in the event of air bubbles in the circuit, bleed the system, see 2.20 (BLEEDING THE BRAKING SYSTEMS).

The leak of brake fluid damages painted or plastic surfaces.

Before setting out, make sure that the hoses are not twisted or holed and that there are no leakage from the connectors.

Do not use or mix different types of silicone or oil-based liquids.

Do not use brake fluids taken from old containers, or not sealed.

Prevent water or dust from accidentally getting into the circuit.

CHECK

NOTE Position the vehicle on firm and flat ground.

- ◆ Position the vehicle on the stand.
- ◆ Turn the handlebar completely rightwards.
- ◆ Make sure that the fluid level exceeds the "MIN" mark.

MIN= minimum level.

MAX= maximum level.

If the fluid does not reach at least the "MIN" mark:

⚠ CAUTION

When the disc pads wear out, the level of the fluid decreases progressively to compensate for their wear.

- ◆ Check the brake pad wear, see 2.27 (CHECKING THE BRAKE PAD WEAR) and the disc wear.

If the pads and/or the disc do not need replacing, provide for topping up.

TOPPING UP

⚠ CAUTION

The brake fluid may flow out of the tank.

Do not operate the front brake lever if the screws (1) are loose or, most important, if the brake fluid tank cover has been removed.

- ◆ Unscrew the two screws (1) of the brake reservoir (2) by means of a short, cross-headed screwdriver.

⚠ WARNING

Avoid any prolonged exposure of the brake fluid to the air.

The brake fluid is hygroscopic and when in contact with the air it absorbs its humidity.

Leave the brake fluid tank open ONLY for the time necessary for topping up.

- ◆ Raise and remove the cover (3) together with the screws (1) and the gasket (4).

NOTE In order not to spill the brake fluid while topping up, do not shake the vehicle.

⚠ CAUTION

Do not put additives or other substances into the fluid.

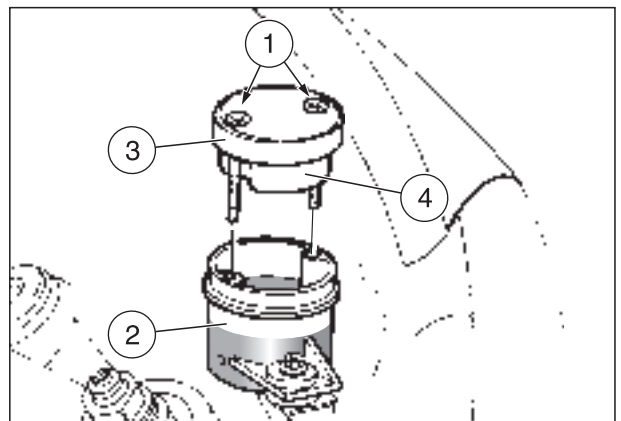
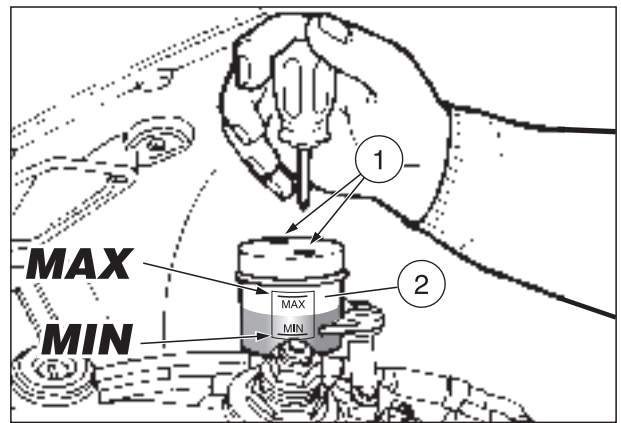

If you use a funnel or other similar items, make sure that they are perfectly clean.

- ◆ Fill the tank (2) with brake fluid, see 1.6 (LUBRICANT CHART), until reaching the correct level between the "MIN" and "MAX" marks.

⚠ CAUTION

Do not exceed the "MAX" level while topping up. It is advisable to top up until reaching the "MAX" level only with new pads. When the disc pads wear out, the level of the fluid decreases progressively to compensate for their wear.

To reassemble the components, follow the reverse order.

2.18 CHECKING AND TOPPING UP THE REAR BRAKE FLUID

Brake fluid:

for the maintenance intervals, see 2.1.1 (REGULAR SERVICE INTERVALS CHART).

CAUTION

If the brake lever features excessive free play, if it is excessively spongy or in the event of air bubbles in the circuit, bleed the system, see 2.20 (BLEEDING THE BRAKING SYSTEMS).

The leak of brake fluid damages painted or plastic surfaces.

Before setting out, make sure that the hoses are not twisted or holed and that there are no leakage from the connectors.

Do not use or mix different types of silicone or oil-based liquids.

Do not use brake fluids taken from old containers, or not sealed.

Prevent water or dust from accidentally getting into the circuit.

CHECK

NOTE Position the vehicle on firm and flat ground.

- ◆ Keep the vehicle in vertical position, so that the fluid contained in the tank (1) is parallel to the plug (2).
- ◆ Make sure that the brake fluid contained in the reservoir exceeds the "MIN" mark, by checking through the appropriate slot on the right fairing".

MIN = minimum level.
MAX = maximum level

If the fluid does not reach at least the "MIN" mark:

CAUTION

When the disc pads wear out, the level of the fluid decreases progressively to compensate for their wear.

- ◆ Check the brake pad wear, see 2.27 (CHECKING THE BRAKE PAD WEAR) and the disc wear.

If the pads and/or the disc do not need replacing, provide for topping up.

TOPPING UP

- ◆ Remove the right fairing, see 7.1.28 (REMOVING THE SIDE FAIRINGS).

CAUTION

The brake fluid may flow out of the tank.

Do not operate the rear brake lever if the brake fluid tank plug is loose or has been removed.

- ◆ Unscrew the screw (3) completely.
- ◆ Slightly move the whole reservoir (1) outwards.

Follow ►

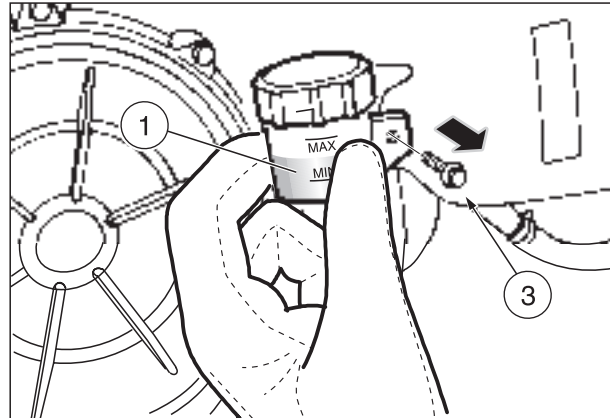
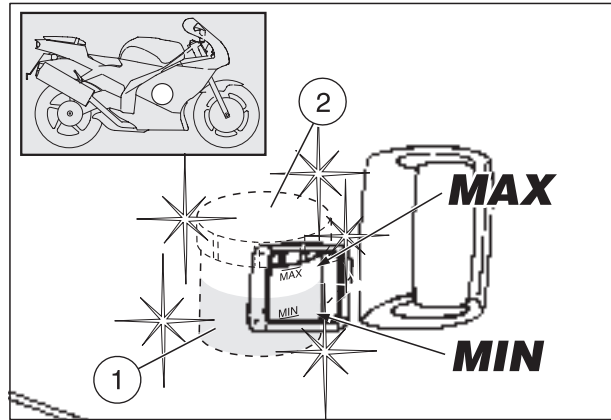

Follow ►

⚠ WARNING

Avoid any prolonged exposure of the brake fluid to the air.

The brake fluid is hygroscopic and when in contact with the air it absorbs its humidity. Leave the brake fluid tank open **ONLY** for the time necessary for topping up.

- ◆ Unscrew and remove the plug (2).

NOTE In order not to spill the brake fluid while topping up, keep the fluid in the tank parallel to the tank rim (in horizontal position).

- ◆ Remove the gasket (4).

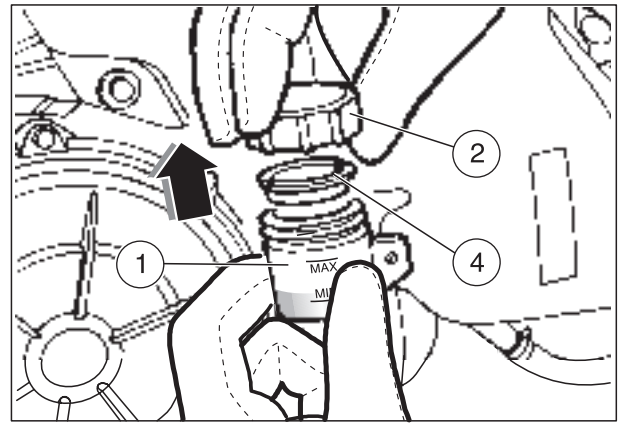
**⚠ CAUTION**

Do not put additives or other substances into the fluid. If you use a funnel or other similar items, make sure that they are perfectly clean.

- ◆ Fill the tank (1) with brake fluid, see 1.6 (LUBRICANT CHART), until reaching the correct level between the "MIN" and "MAX" marks.

⚠ CAUTION

It is advisable to top up until reaching the "MAX" level only with new pads. When the disc pads wear out, the level of the fluid decreases progressively to compensate for their wear.

- ◆ To reassemble the components, follow the reverse order.



2.19 CHECKING AND TOPPING UP THE CLUTCH FLUID

Carefully read 0.5.1 (PRECAUTIONS AND GENERAL INFORMATIONS) and 1.2.6 (CLUTCH FLUID).

Clutch fluid:

for the maintenance intervals, see 2.1.1 (REGULAR SERVICE INTERVALS CHART).

⚠ CAUTION

If the clutch control lever features excessive free play, if it is excessively spongy or in the event of air bubbles in the circuit, bleed the system, see 2.21 (BLEEDING THE CLUTCH SYSTEMS).

The leak of clutch fluid damages painted or plastic surfaces.

Before setting out, make sure that the hoses are not twisted or holed and that there are no leakage from the connectors.

Do not use or mix different types of silicone or oil-based liquids.

Do not use clutch fluids taken from old containers, or not sealed.

Prevent water or dust from accidentally getting into the circuit.

CHECK

NOTE Position the vehicle on firm and flat ground.

If the fluid does not reach at least the "MIN" mark:

⚠ CAUTION

When the disc pads wear out, the level of the fluid decreases progressively to compensate for their wear.

◆ Check the brake pad wear, see 2.27 (CHECKING THE BRAKE PAD WEAR) and the disc wear.

If the pads and/or the disc do not need replacing, provide for topping up.

◆ Make sure that the fluid level exceeds the "MIN" mark.

MIN= minimum level.

MAX= maximum level.

◆ If the fluid does not reach the "MIN" mark, provide for topping up.

TOPPING UP

⚠ CAUTION

The fluid may flow out.

Do not operate the clutch control lever if the reservoir plug is loose or has been removed.

⚠ WARNING

Avoid any prolonged exposure of the clutch fluid to the air.

The clutch fluid is hygroscopic and when in contact with the air it absorbs its humidity.

Leave the clutch fluid tank open ONLY for the time necessary for topping up.

◆ Unscrew and remove the plug (2).

NOTE Do not shake the vehicle, in order not to spill fluid while topping up.

◆ Remove the gasket (3).

⚠ CAUTION

Do not put additives or other substances into the fluid. If you use a funnel or other similar items, make sure that they are perfectly clean.

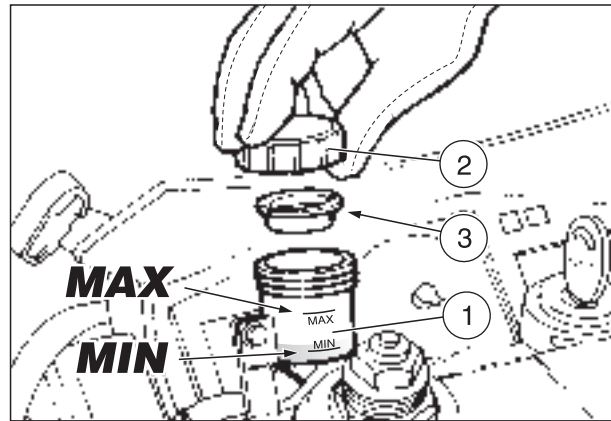

◆ Top up the reservoir (1) by adding clutch fluid, see 1.6 (LUBRICANT CHART), until reaching the correct level included between the "MIN" and "MAX" marks.

⚠ CAUTION

Do not exceed the "MAX" level while topping up.

◆ To reassemble the components, follow the reverse order.

2.20 BLEEDING THE BRAKING SYSTEMS

Carefully read 0.5.1 (PRECAUTIONS AND GENERAL INFORMATIONS) and 1.2.6 (CLUTCH FLUID).

Brake fluid bleeding, braking systems:

for the maintenance intervals, see 2.1.1 (REGULAR SERVICE INTERVALS CHART).

⚠ CAUTION

Sudden resistance or clearance problems on the clutch lever may be due to troubles in the hydraulic system.

The air present in the hydraulic system acts as a bearing, absorbing most of the pressure exerted by the brake pump and reducing the effectiveness of the caliper action during braking.

The presence of air is revealed by the "sponginess" of the brake lever and with the reduced braking capacity.

⚠ WARNING

Considering the danger for both rider and vehicle, it is absolutely essential to bleed the hydraulic circuit once the brakes have been refitted and the braking system restored to its normal conditions.

If the brake fluid gets in contact with the skin or the eyes, it can cause serious irritations. Carefully wash the parts of your body that get in contact with the liquid. Consult a doctor or an oculist if the liquid gets in contact with your eyes.

DO NOT DISPOSE OF THE FLUID IN THE ENVIRONMENT.

KEEP AWAY FROM CHILDREN.

⚠ CAUTION

Handle brake fluid with care; it may chemically alter painted surfaces and the parts in plastic, rubber, etc.

In case any maintenance operation has to be carried out, it is advisable to use latex gloves.

When using the brake fluid, take care not to spill it on the plastic or painted parts, since it can damage them.

Do not use alcohol, petrol or solvents to clean the rubber and plastic parts and the saddle: use only water and mild soap.

The air bleeding operations must be carried out on all the bleeder valves present on the system to be bled.

FRONT BRAKING SYSTEM

The front braking system is provided with three bleeder valves:

- one valve (1) on the pump;
- one valve (2) on each one of the two front brake calipers.

Repeat the BLEEDING OPERATIONS on both valves (2), see 2.20.1 (BLEEDING OPERATIONS).

REAR BRAKING SYSTEM

The rear braking system is equipped with a single bleeder valve (3) positioned on the rear brake caliper.

Follow ►

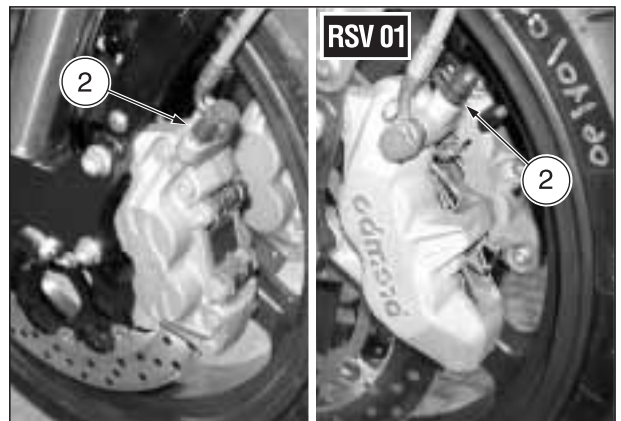

Follow ►

2.20.1 BLEEDING OPERATIONS

NOTE Carry out the bleeding operations with the vehicle positioned on the side stand and on firm and flat ground.

Only for the rear braking system.

- ◆ Unscrew and remove the two screws (4) and recover the relevant washers.
- ◆ Remove the protection element (5).

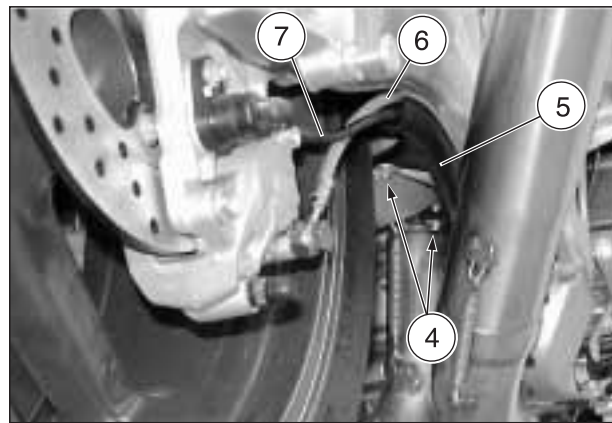

⚠ CAUTION

Upon reassembly, anchor the rear brake pipe (6) and the speed sensor cable (7) with the protection element (5).

NOTE During the bleeding operations keep the rear brake pipe as straight as possible.

NOTE Do not work on both braking systems at the same time. The operations refer to a single braking system, but are valid for both (with the differences indicated).

NOTE Do not close the brake fluid reservoir after topping up, since for the bleeding operations it is necessary to top up the brake fluid reservoir more than once.

- ◆ Top up the brake fluid tank, see 2.17 (CHECKING AND TOPPING UP THE FRONT BRAKE FLUID) or 2.18 (CHECKING AND TOPPING UP THE REAR BRAKE FLUID).

⚠ WARNING

Always wear goggles or a protective screen for the eyes: when the brake lever (or the brake pads) is operated, part of the brake fluid may be sprayed out of the brake fluid reservoir.

⚠ CAUTION

Position a clean cloth under the brake fluid reservoir to protect the components positioned in the surrounding area.

⚠ CAUTION

Make sure that the brake fluid level is always included between the MIN and MAX marks; otherwise, provide for topping up.

⚠ WARNING

The handlebar can be turned only to the right. The brake fluid may flow out of the tank from the tank.

- ◆ Remove the protection cap (8) from the bleeder valve (9).
- ◆ Connect a transparent pipe (10) to the bleeder valve (9).
- ◆ Position the free end of the transparent pipe (10) into a container (11).

Follow ►

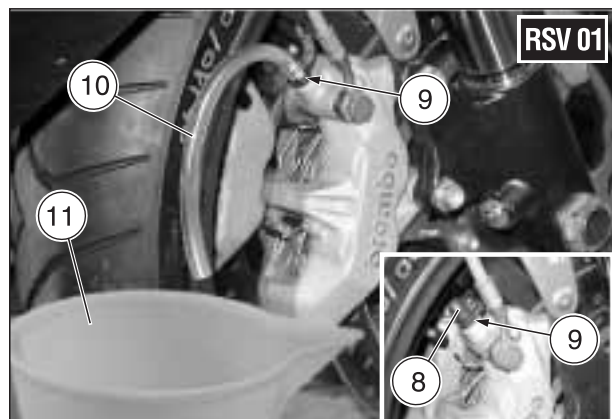
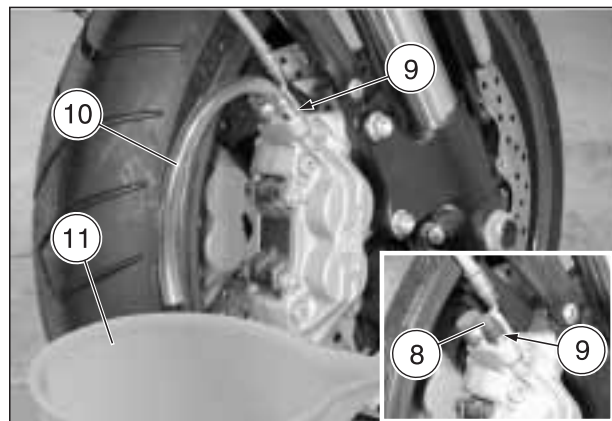

Follow ►

- ◆ * Slowly operate the brake lever (12) (for the front brake, or the brake pump rod for the rear brake) more than once, in order to fill the system with brake fluid and to carry out a first partial bleeding.
- ◆ * Pull the brake lever (12) (for the front brake, or the brake pump rod for the rear brake) slowly and thoroughly, then keep it completely pulled.

⚠ WARNING

Check the brake fluid level in the tank. Top up before draining the brake fluid reservoir completely. The complete drainage of the fluid causes the inlet of air into the hydraulic circuit.

NOTE Always keep the brake lever (12) (for the front brake, or the brake pump rod for the rear brake) completely pulled.

⚠ CAUTION

Do not dirty the brake pads or disc with brake fluid.

⚠ CAUTION

Before releasing the brake lever (12) (for the front brake, or the brake pump rod for the rear brake), tighten the bleeder valve (9) to prevent air from getting into the hydraulic circuit.

- ◆ * Loosen the bleeder a quarter turn so that the clutch fluid flows into the container; this eliminates the tension on the clutch lever, allowing it to touch the handgrip.
- ◆ * Tighten the bleeder (9).
- ◆ * Release the brake lever (12) (for the front brake, or the brake pump rod for the rear brake) and pull it three or four times.
- ◆ Repeat the operations marked with “*”, until no air bubbles can be seen in the brake fluid that flows out of the bleeder valve.

NOTE During the performance of these operations, more and more resistance will be met when operating the brake lever (12) (for the front brake, or the brake pump rod for the rear brake). The resistance is due to the air escape from the braking system.

- ◆ **If there are other bleeder valves.** Repeat the bleeding operations on the other bleeder valves present in the system.

If no air bubbles can be noticed in the brake fluid:

- ◆ If the resistance met when pulling the brake lever (12) (for the front brake, or the brake pump rod for the rear brake) is correct, this means that the system does not need further bleeding.
- ◆ Top up the brake fluid tank, see 2.17 (CHECKING AND TOPPING UP THE FRONT BRAKE FLUID) or 2.18 (CHECKING AND TOPPING UP THE REAR BRAKE FLUID).
- ◆ Correctly close the rear brake reservoir.

⚠ CAUTION

Clean the transparent pipe (for its whole length) and the bleeder valve, removing any residue of brake fluid.

- ◆ Remove the transparent pipe (10).
- ◆ Tighten the bleeder (9) to prescribed driving torque.

Brake caliper bleeder valve driving torque: 15 Nm (1.5 kgm).

- ◆ Position the protection cap (8) on the bleeder valve (9).

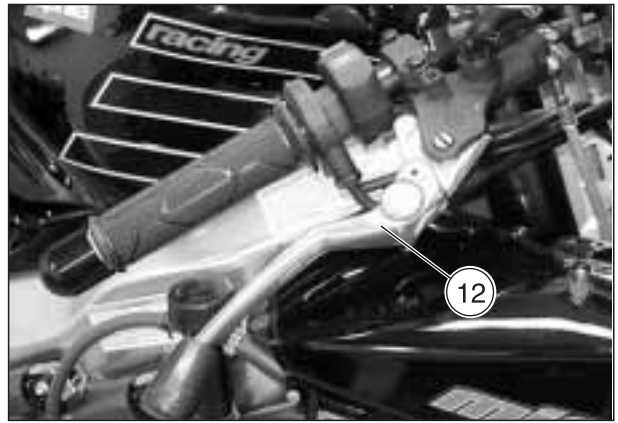

- ◆ **For the rear braking system only.** Position the rear brake pipe correctly and put back all the components that were removed to release the rear brake pipe.

DO NOT DISPOSE OF THE FLUID IN THE ENVIRONMENT.

- ◆ Empty the container (11) into a suitable receptacle for the collection of used brake fluid.

Carefully read 2.20.2 (CHECKS TO BE CARRIED OUT AFTER BLEEDING THE BRAKING SYSTEMS).

2.20.2 CHECKS TO BE CARRIED OUT AFTER BLEEDING THE BRAKING SYSTEMS

After bleeding the braking systems, keep to the following indications.

Make sure that the brake discs and the brake pads are completely free of grease or oil.

⚠ WARNING

Pull the brake lever (for the front brake, or the brake pump rod for the rear brake) repeatedly and verify the correct operation of the braking system.

⚠ WARNING

Have a test ride at moderate speed in a low-traffic area.

2.21 BLEEDING THE CLUTCH SYSTEMS

Carefully read 0.5.1 (PRECAUTIONS AND GENERAL INFORMATIONS) and 1.2.6 (CLUTCH FLUID).

NOTE This vehicle is provided with hydraulic clutch control.

Clutch fluid bleeding, clutch control system:

for the maintenance intervals, see 2.1.1 (REGULAR SERVICE INTERVALS CHART).

⚠ CAUTION

Sudden resistance or clearance problems on the clutch lever may be due to troubles in the hydraulic system.

The air present in the hydraulic system acts as a bearing, absorbing most of the pressure exerted by the brake pump and reducing the effectiveness of the clutch cylinder.

The presence of air is revealed by the "sponginess" of the clutch control and by reduced efficiency (the engine stops, the vehicle jerks forward or rears up, or the clutch slips).

⚠ WARNING

Considering that the situation can be very dangerous for the rider and the vehicle, after the reassembly of the clutch control cylinder and/or after the normal operating conditions of the clutch system have been restored, it is absolutely necessary to bleed the hydraulic circuit.

If the clutch fluid gets in contact with the skin or the eyes, it can cause serious irritations.

Carefully wash the parts of your body that get in contact with the liquid. Consult a doctor or an oculist if the liquid gets in contact with your eyes.

DO NOT DISPOSE OF THE FLUID IN THE ENVIRONMENT.

KEEP AWAY FROM CHILDREN.

⚠ CAUTION

Handle clutch fluid with care; it may chemically alter painted surfaces and the parts in plastic, rubber, etc.

In case maintenance operations are to be performed on the hydraulic circuit, it is advisable to use latex gloves.

When using the clutch fluid, take care not to spill it on the plastic and painted parts, since it damages them.

Do not use alcohol, petrol or solvents to clean the rubber and plastic parts and the saddle: use only water and mild soap.

2.21.1 BLEEDING OPERATIONS

NOTE Carry out the bleeding operations with the vehicle positioned on the side stand and on firm and flat ground.

NOTE Do not close the clutch fluid reservoir after topping up, since for the bleeding operations it is necessary to top up the clutch fluid reservoir more than once.

◆ Top up the clutch fluid tank, see 2.17 (CHECKING AND TOPPING UP THE FRONT BRAKE FLUID).

⚠ WARNING

Always wear goggles or a protective screen for the eyes: when the clutch lever (or the clutch control cylinder) is operated, part of the clutch fluid may be sprayed out of the clutch fluid reservoir.

⚠ CAUTION

Position a clean cloth under the clutch control reservoir to protect the components positioned in the surrounding area.

⚠ CAUTION

Make sure that the clutch fluid level is always included between the MIN and MAX marks; otherwise, provide for topping up.

⚠ WARNING

The handlebar can be turned only to the right. The clutch fluid may flow out of the tank from the tank.

⚠ CAUTION

The bleeder valve (2) is positioned on the clutch control cylinder connection screw (A).

Work only on the bleeder valve (2), DO NOT unscrew the clutch control cylinder connection screw (A).

- ◆ Remove the protection cap (1) from the bleeder valve (2).
- ◆ Connect a transparent pipe (3) to the bleeder valve (2).
- ◆ Position the free end of the transparent pipe (3) into a container (4).
- ◆ * Pull the clutch lever (5) slowly more than once, so that the system is filled with clutch fluid and a first partial bleeding is carried out.
- ◆ * Pull the clutch lever (5) slowly and thoroughly, then keep it completely pulled.

⚠ WARNING

Check the clutch fluid level in the tank. Top up before draining the brake fluid reservoir completely. The complete drainage of the fluid causes the inlet of air into the hydraulic circuit.

NOTE Always keep the clutch control lever (5) completely pulled.

⚠ CAUTION

Do not dirty other parts of the engine and of the vehicle with clutch fluid.

⚠ CAUTION

Before releasing the clutch lever (5), tighten the bleeder valve (2) to prevent air from getting into the hydraulic circuit.

- ◆ * Loosen the bleeder a quarter turn so that the clutch fluid flows into the container; this eliminates the tension on the clutch lever, allowing it to touch the handgrip.
- ◆ * Tighten the bleeder (2).
- ◆ * Release the clutch lever (5) and pull it three or four times.

RSV mille

- ◆ Repeat the operations marked with “*”, until no air bubbles can be seen in the clutch fluid that flows out of the bleeder valve.

NOTE During these operations the resistance met when pulling the clutch lever (5) will increase. The resistance is due to the air escape from the braking system.

If no air bubbles can be noticed in the clutch fluid:

- ◆ If the resistance met when pulling the clutch lever (5) is correct, this means that the system does not need further bleeding.
- ◆ Top up the clutch fluid tank, see 2.17 (CHECKING AND TOPPING UP THE FRONT BRAKE FLUID).
- ◆ Correctly close the clutch fluid reservoir.

⚠ CAUTION

Clean the transparent pipe (for its whole length) and the bleeder valve, removing any residue of clutch fluid.

- ◆ Remove the transparent pipe (3).
- ◆ Tighten the bleeder (2) to prescribed driving torque.

Clutch fluid bleeder valve driving torque: 15 Nm (1.5 kgm).

- ◆ Position the protection cap (1) on the bleeder valve (2).

DO NOT DISPOSE OF THE FLUID IN THE ENVIRONMENT.

- ◆ Empty the container (4) into a suitable receptacle for the collection of used clutch fluid.

Carefully read 2.21.2 (CHECKS TO BE CARRIED OUT AFTER BLEEDING THE CLUTCH CONTROL SYSTEM).

2.21.2 CHECKS TO BE CARRIED OUT AFTER BLEEDING THE CLUTCH CONTROL SYSTEM

After bleeding the clutch control system, keep to the following indications.

⚠ WARNING

Pull the clutch lever repeatedly and verify the correct operation of the clutch control system.

When the clutch is released, the vehicle must start regularly and smoothly.

The following should not occur:

- engine stop;
- jerking forward of the vehicle;
- rearing up.
- clutch slipping.

⚠ WARNING

Have a test ride at moderate speed in a low-traffic area.

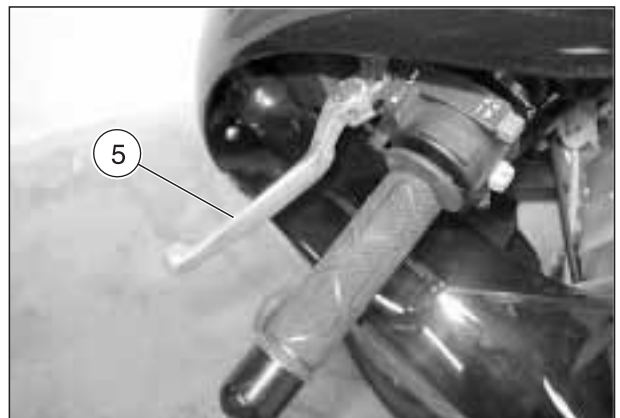
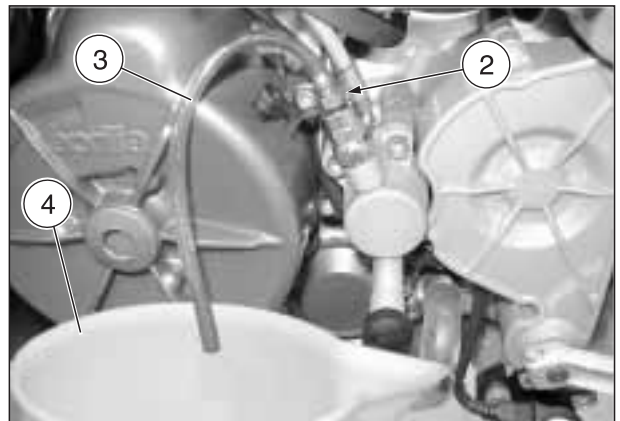
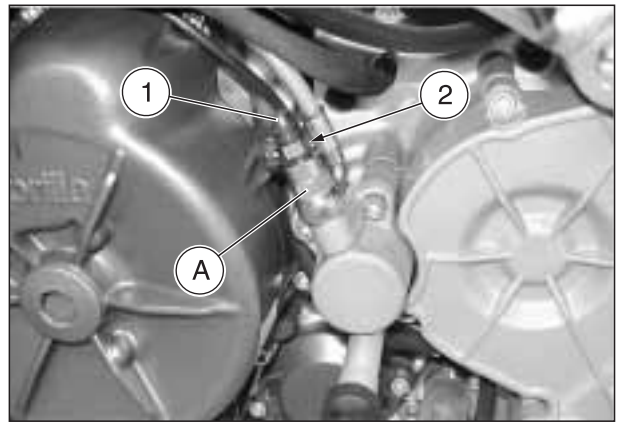

2.22 CHANGING THE FRONT BRAKE FLUID

Carefully read 0.5.1 (PRECAUTIONS AND GENERAL INFORMATIONS) and 1.2.4 (BRAKE FLUID).

Brake fluid:

for the maintenance intervals, see 2.1.1 (REGULAR SERVICE INTERVALS CHART).

⚠ CAUTION

Handle brake fluid with care; it may chemically alter painted surfaces and the parts in plastic, rubber, etc.

DO NOT DISPOSE OF THE FLUID IN THE ENVIRONMENT.

- ◆ ★ Remove the plastic protection cap.
- ◆ ★ Insert a transparent plastic tube on the bleeder (1) of the caliper and put the other end of the tube in a container.
- ◆ ★ Loosen the bleeder (1) approx. one turn.

NOTE Make sure that there is always fluid in the tank during the operation; otherwise, once finished, the system will need bleeding, see 2.20 (BLEEDING THE BRAKING SYSTEMS).

- ◆ Keep an eye on the tank (2) as the fluid flows out and tighten the bleeder (1) before it empties entirely.
- ◆ Top up the tank (2), see 2.17 (CHECKING AND TOPPING UP THE FRONT BRAKE FLUID).
- ◆ ★ Loosen the bleeder (1) again approx. half a turn.
- ◆ ★ Watch as the liquid flows out through the tube and as soon as the colour of the fluid starts to change (from dark to light), tighten the bleeder (1) again and remove the tube.

Bleeder (1) driving torque: 15 Nm (1.5 kgm).

- ◆ ★ Refit the rubber protection cap.
- ◆ Top up the fluid tank (2) to the right level, see 2.17 (CHECKING AND TOPPING UP THE FRONT BRAKE FLUID).

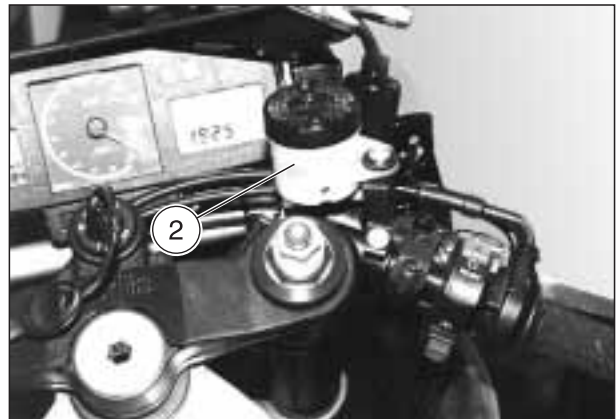
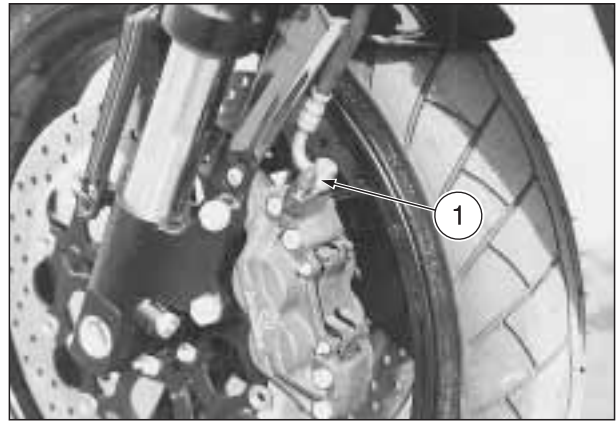

2.23 CHANGING THE REAR BRAKE FLUID

Carefully read 0.5.1 (PRECAUTIONS AND GENERAL INFORMATIONS) and 1.2.4 (BRAKE FLUID).

Brake fluid:

for the maintenance intervals, see 2.1.1 (REGULAR SERVICE INTERVALS CHART).

⚠ CAUTION

Handle fluid with care; it may chemically alter painted surfaces and the parts in plastic, rubber, etc.

DO NOT DISPOSE OF THE FLUID IN THE ENVIRONMENT.

- ◆ Remove the plastic protection cap.
- ◆ Insert a transparent plastic tube on the bleeder (1) of the caliper and put the other end of the tube in a container.
- ◆ Loosen the bleeder (1) approx. one turn.

NOTE Make sure that there is always fluid in the tank during the operation; otherwise, once finished, the system will need bleeding, see 2.20 (BLEEDING THE BRAKING SYSTEMS).

- ◆ Keep an eye on the tank (2) as the fluid flows out and tighten the bleeder (1) before it empties entirely.
- ◆ Top up the tank (2), see 2.18 (CHECKING AND TOPPING UP THE REAR BRAKE FLUID).
- ◆ Loosen the bleeder (1) again approx. half a turn.
- ◆ Watch as the liquid flows out through the tube and as soon as the colour of the fluid starts to change (from dark to light), tighten the bleeder (1) again and remove the tube.

Bleeder (1) driving torque: 15 Nm (1.5 kgm).

- ◆ Refit the rubber protection cap.
- ◆ Top up the fluid tank (2) to the right level, see 2.18 (CHECKING AND TOPPING UP THE REAR BRAKE FLUID).

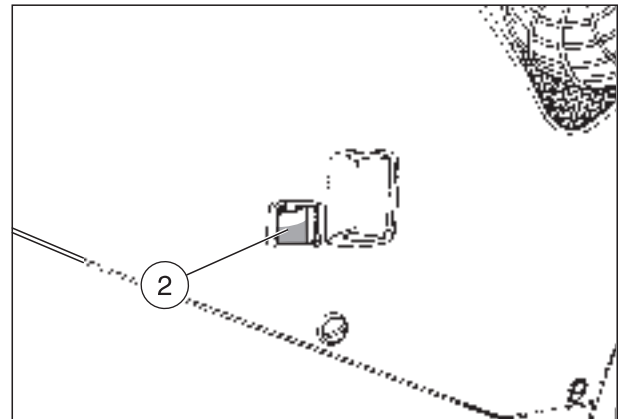
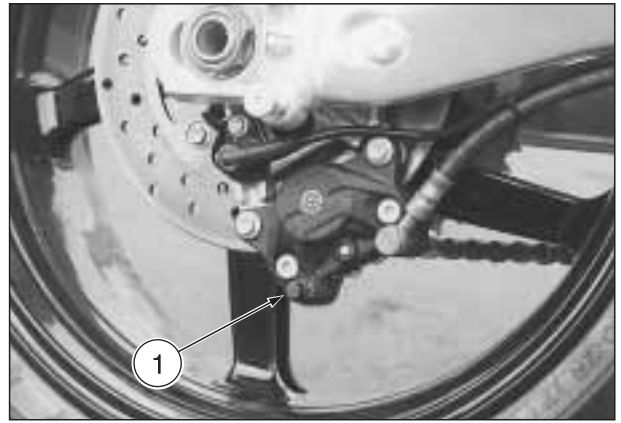

2.24 CHANGING THE CLUTCH FLUID

Carefully read 0.5.1 (PRECAUTIONS AND GENERAL INFORMATIONS) and 1.2.6 (CLUTCH FLUID).

Clutch fluid:

for the maintenance intervals, see 2.1.1 (REGULAR SERVICE INTERVALS CHART).

⚠ CAUTION

Handle fluid with care; it may chemically alter painted surfaces and the parts in plastic, rubber, etc.

DO NOT DISPOSE OF THE FLUID IN THE ENVIRONMENT.

- ◆ Remove the plastic protection cap.
- ◆ Insert a transparent plastic tube on the bleeder (1) and put the other end of the tube in a container.
- ◆ Loosen the bleeder (1) approx. one turn.

NOTE Make sure that there is always fluid in the tank during the operation; otherwise, once finished, the system will need bleeding, see 2.21 (BLEEDING THE CLUTCH SYSTEMS).

- ◆ Keep an eye on the tank (2) as the fluid flows out and tighten the bleeder (1) before it empties entirely.
- ◆ Top up the tank (2), see 2.19 (CHECKING AND TOPPING UP THE CLUTCH FLUID).
- ◆ Loosen the bleeder (1) again approx. half a turn.
- ◆ Watch as the liquid flows out through the tube and as soon as the colour of the fluid starts to change (from dark to light), tighten the bleeder (1) again and remove the tube.

Bleeder (1) driving torque: 15 Nm (1.5 kgm).

- ◆ Refit the rubber protection cap.
- ◆ Top up the fluid tank (2) to the right level, see 2.19 (CHECKING AND TOPPING UP THE CLUTCH FLUID).

2.25 ADJUSTING THE REAR BRAKE CONTROL LEVER AND THE GEAR LEVER

The control levers are positioned ergonomically during the assembly of the vehicle.

If necessary, it is possible to adjust the position of the levers.

- ◆ Position the vehicle on the stand.
- ◆ Partially unscrew the screw (3).
- ◆ Rotate the eccentric (4) in order to find the optimal position of the pedal (5).
- ◆ Tighten the screw (3) and make sure that the eccentric is stable in its position.

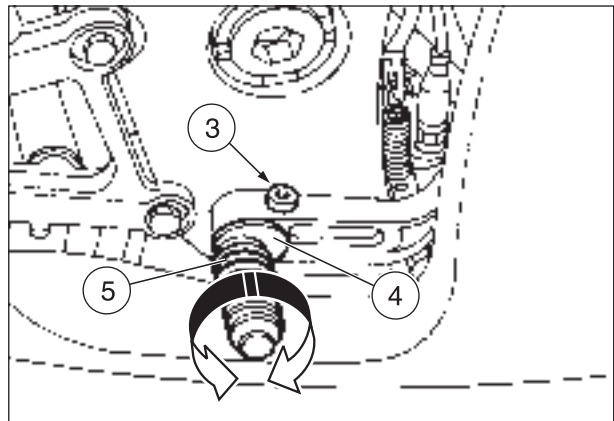
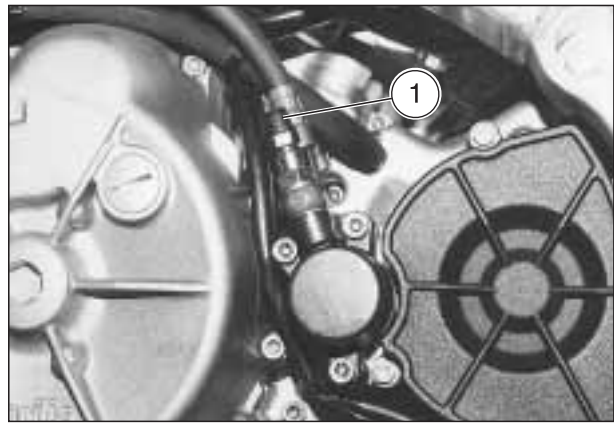

2.26 ADJUSTING THE REAR BRAKE CONTROL LEVER CLEARANCE

Carefully read 0.5.1 (PRECAUTIONS AND GENERAL INFORMATIONS).

The brake control lever is positioned ergonomically during the assembly of the vehicle.
If necessary, it is possible to adjust the brake control lever clearance:

- ◆ Remove the lower fairing, see 7.1.34 (REMOVING THE LOWER FAIRING).
- ◆ Tighten the lock nut (1).
- ◆ Unscrew the pump control rod (2) to ensure a minimum clearance of **0.5 – 1 mm** between the rod and the pump piston.

⚠ CAUTION

Make sure that there is a certain idle stroke in the movement of the lever, to prevent the brake from remaining applied and the consequent untimely wear of the braking elements.

Lever (3) idle stroke:

4 mm (measured at the lever end).

- ◆ Lock the pump control rod by means of the lock nut (1).

⚠ CAUTION

After the adjustment, make sure that the wheel rotates freely with released brake.

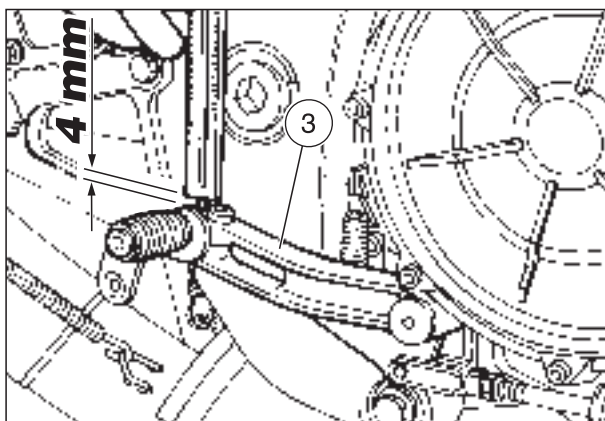
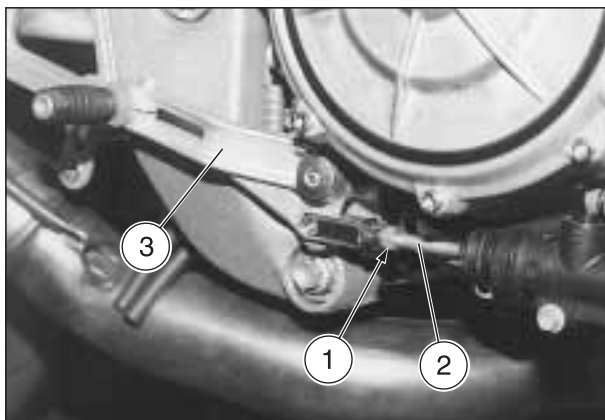

2.27 CHECKING THE BRAKE PAD WEAR

Brake pad wear, brake pads:

for the maintenance intervals, see 2.1.1 (REGULAR SERVICE INTERVALS CHART).

The wear of the disc brake pads depends on the use, on the kind of drive and on the road.

NOTE The following information refer to a single braking system, but are valid for both.

⚠ WARNING

This vehicle is equipped with a double-disc front braking system (right side and left side).

Always check all the pads of both the front brake calipers.

Checking the pads of one front caliper only may affect the stability and safety of the vehicle, with serious risks for persons, property and the vehicle itself.

To carry out a rapid checking of the wear of the pads, proceed as follows:

- ◆ Position the vehicle on the stand.

NOTE Both front brake calipers (right and left) are equipped with two (RSV 01 four) brake pads. The rear brake caliper is provided with two brake pads.

- ◆ Carry out a visual check between the disc and the pads, proceeding:
 - from below, on the front part, for the front brake calipers front brake (1);
 - RSV 01 from above, on the rear part, for the front brake calipers (1);
 - from below, on the rear part, for the rear brake caliper (2).

Follow ►

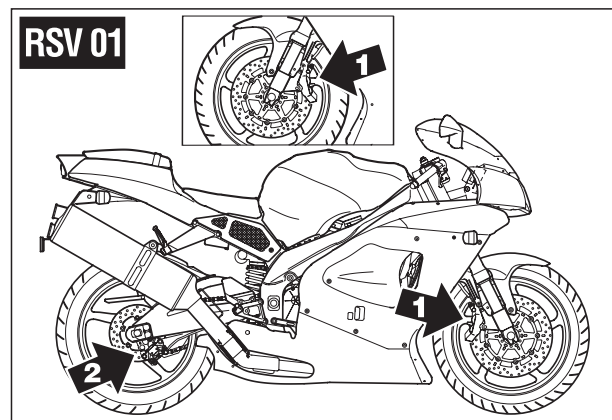
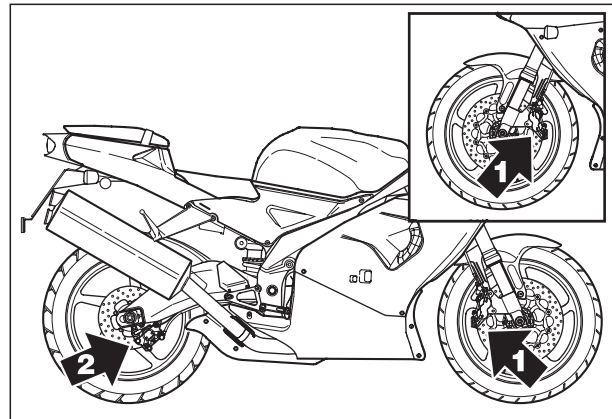

Follow ►

CAUTION

The excessive wear of the friction material would cause the contact of the pad metal support with the disc, with consequent metallic noise and production of sparks from the caliper; braking efficiency, safety and soundness of the disc would thus be negatively affected.

If the thickness of the friction material [even of one front (3) or rear pad (4) only] has reduced to about **1.5 mm** (or even if only one of the wear indicators is not visible any longer):

- for the front brake calipers (right and left), have all pads of both calipers changed, see 7.5.1 (CHANGING THE FRONT BRAKE PADS (models up to 2001)).
- for the rear brake caliper have both rear brake caliper pads changed, see 7.6.1 (CHANGING THE REAR BRAKE PADS).

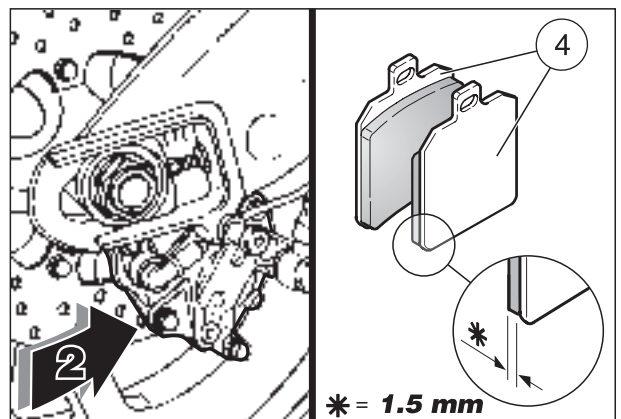
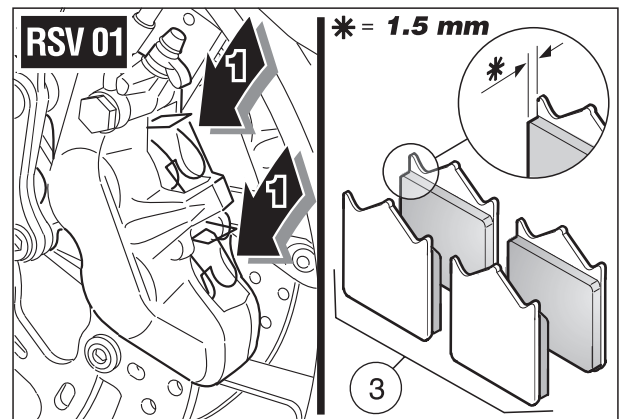
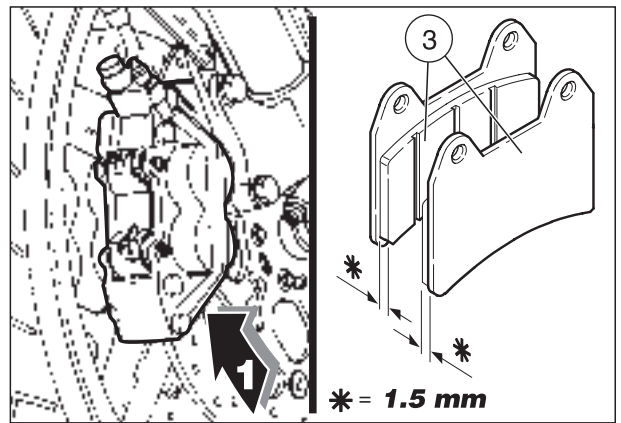

2.28 STEERING

Carefully read 0.5.1 (PRECAUTIONS AND GENERAL INFORMATIONS).

To assure improved handling, the steering is equipped with rolling bearings.
The steering must be adjusted correctly to provide smooth rotation of the handlebar and safe driving.
Tight steering hinders the smooth rotation of the handlebar whereas slack steering implies inadequate stability.

2.28.1 CHECKING THE BEARING SLACK STEERING

Steering bearings and steering clearance:

for the maintenance intervals, see 2.1.1 (REGULAR SERVICE INTERVALS CHART).

- ◆ Position the vehicle on the special centre stand, see 1.8.4 (POSITIONING THE VEHICLE ON THE CENTRE SUPPORT STAND **OPT**).
- ◆ Shake the fork in the direction of travel.
- ◆ In the event any slack is encountered, adjust the steering, see 2.28.2 (ADJUSTING THE BEARING SLACK STEERING).

2.28.2 ADJUSTING THE BEARING SLACK STEERING

Carefully read 0.5.1 (PRECAUTIONS AND GENERAL INFORMATIONS).

- ◆ Partially remove the fork upper plate, see 7.1.19 (REMOVING THE FORK UPPER PLATE).

NOTE The safety washer (1) has four tabs, two bent upwards and two bent downwards. To release the counter-ring (2) it is necessary to straighten the two tabs that are bent upwards.
To straighten the tabs, use a small flat-tip screwdriver.

- ◆ Use a small flat-tip screwdriver to straighten the tabs (those bent upwards) of the tab washer (1).

NOTE Have the appropriate special tool **OPT** to hand:
– **aprilia** part# 8140203 (complete tool kit for frame including).

- ◆ Use the special setscrew spanner to loosen and remove the lock ring (2).
- ◆ Remove the tab washer (1).

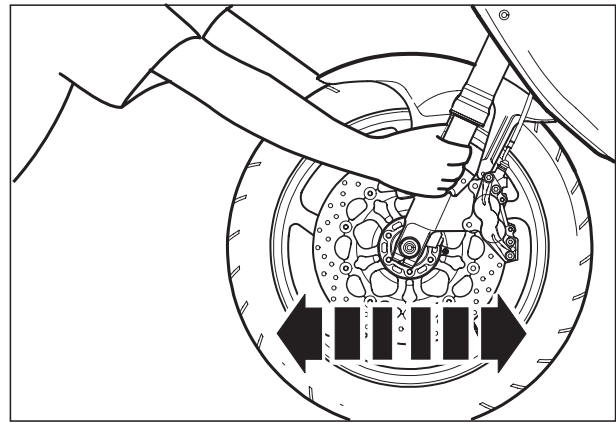

⚠ WARNING

Apply the prescribed driving torque. Exceeding the prescribed driving torque means damaging the steering bearings and the sliding seats, with serious consequences for the functionality of the steering and the safety of the vehicle, people and property.

Follow ►

Follow ►

Adjuster ring (3) driving torque: 40 Nm (4.0 kgm).

- ◆ Use the special setscrew spanner to tighten the adjuster ring (3) and eliminate the slack.

⚠ CAUTION**When reassembling, the tab washer (1) must be replaced.**

- ◆ Position the safety washer (1) so that the tabs coincide with the grooved sections of the adjusting metal ring (3).
- ◆ Bend the two (diametrically opposite) tabs of the safety washer (1) downwards.

Counter-ring (2) driving torque: contact + 1/4 turn.

- ◆ Lock the adjusting metal ring (3) and tighten the counter-ring (2) (the grooved sections of the two rings must coincide).
- ◆ Bend the two tabs of the safety washer (1) upwards, inserting them in the grooves of the counter-ring (2).
- ◆ Refit the fork upper plate (3), see 7.1.19 (REMOVING THE FORK UPPER PLATE).

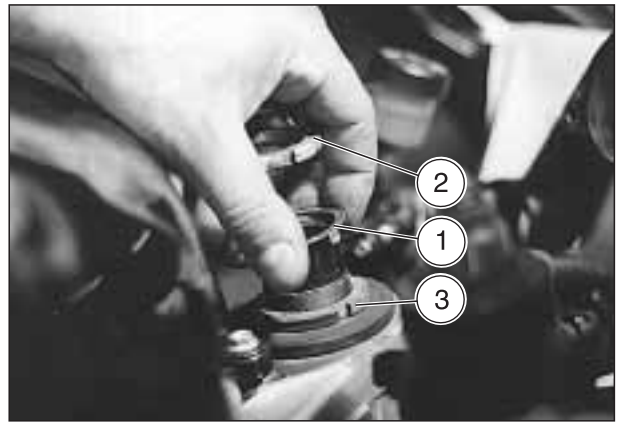
⚠ CAUTION**Once the operation is complete, make sure that the rotation of the handlebar is smooth in order to avoid damage to the balls and the loss of manoeuvrability of the vehicle.**

2.29 INSPECTING THE FRONT AND REAR SUSPENSION

Carefully read 0.5.1 (PRECAUTIONS AND GENERAL INFORMATIONS).

2.29.1 FRONT SUSPENSION

The front suspension consists of an hydraulic fork connected to the steering column by means of two plates.

For the setting of the vehicle attitude, each rod of the fork is provided with an upper screw (1) for the adjustment of the hydraulic braking with extended shock absorber, a lower screw (2) for the adjustment of the hydraulic braking with compressed shock absorber and an upper nut (3) for the adjustment of the spring preload.

The riding position of the vehicle can be further altered by varying the height of the forecarriage.

Fork, fork oil, fork oil seals:

for the maintenance intervals, see 2.1.1 (REGULAR SERVICE INTERVALS CHART).

For the check, proceed as follows:

- ◆ With pulled front brake lever, press the handlebar repeatedly, thrusting the fork downwards. The stroke must be gentle and there must be no trace of oil on the rods.

If the fork tends to "bottom out", carry out a adjusting, see 2.29.2 (ADJUSTING THE FRONT FORK) and the oil must be changed if necessary, see 7.8.1 (CHANGING THE FORK OIL).

Make sure the fork does not feature oil leaks and that the outer surface of the tubes is not marked with scratches or grooves.

If this is the case, replace all the damaged parts that cannot be repaired, see 7.8.3 (DISASSEMBLING THE WHEEL-HOLDER TUBE - SLIDER UNIT).

- ◆ Check the fastening of all the components and the functionality of the front suspension joints.

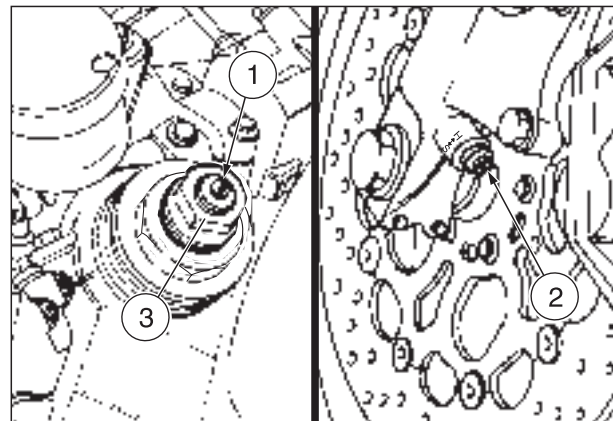
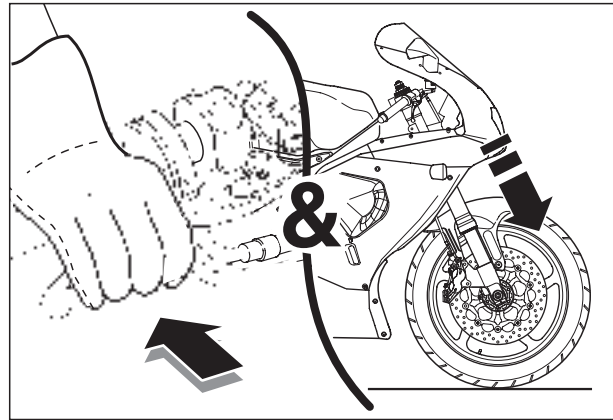

2.29.2 ADJUSTING THE FRONT FORK

The standard setting of the front fork is such as to satisfy most driving conditions at low and high speed, either with reduced load and full load. However, it is possible to adjust the setting according to how the vehicle is going to be used.

⚠ CAUTION

For the adjustment, always start from the most rigid setting [complete clockwise rotation of the adjusters (1-2)].

Do not force the rotation of the adjusters (1) (2) beyond the end of stroke in both directions, in order to avoid any damage.

Use the notches (1-2) provided on the adjusters as reference marks for the adjustment of the hydraulic braking with compressed and extended shock absorber.

Give the adjusters (1-2) 1/8 turn at a time and turn the adjusting nut (3) one notch at a time. Test the vehicle repeatedly on the road, until obtaining the optimal adjustment.

Set the same spring preload and hydraulic braking for both rods: a different setting of the rods decreases the stability of the vehicle while riding.

When the spring preload is increased, it is necessary to increase also the hydraulic braking, in order to avoid sudden jerks while riding.

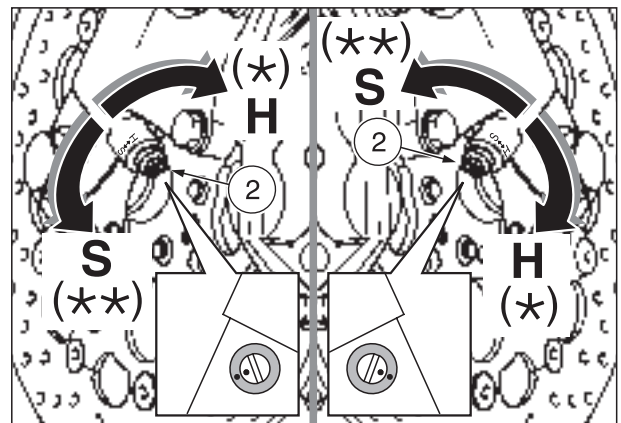
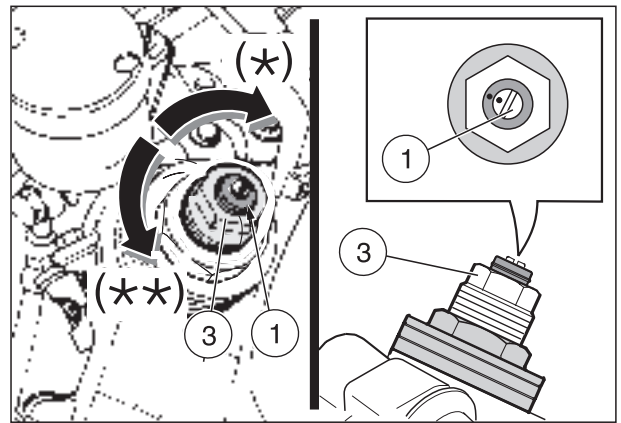

ADJUSTMENT TABLE

Front suspension	Standard adjustment	Adjustment for racetrack use
Hydraulic adjustment with extended shock absorber, screw (1)	from completely closed (*) open giving 1.5 turns (**)	from completely closed (*) open giving 1 turn (**)
Hydraulic adjustment with compressed shock absorber, screw (2)	from completely closed (*) (H) open giving 1.5 turns (**) (S)	from completely closed (*) (H) open giving 1 turn (**) (S)
Spring preload, nut (3)	at the 5 th notch	at the 4 th notch

RSV 01

Front suspension	Standard adjustment	Adjustment for racetrack use
Hydraulic adjustment with extended shock absorber, screw (1)	from completely (*) closed open (**) giving 1.25 turns	from completely closed (*) open giving (**) 0,5 – 1 turn
Hydraulic adjustment with compressed shock absorber, screw (2)	from completely closed (*) (H) open (**) (S) giving 1 turn	from completely closed (*) (H) open (**) (S) giving 0,5 – 1 turn
Spring preload, nut (3)	from completely closed (*) open (**) giving 4 – 5 reference notches	
Protrusion of the rods (A) (***) from the upper plate (plug excluded)	3 reference notches	4 reference notches

(*) = clockwise
(**) = anticlockwise

2.29.3 ADJUSTING THE HEIGHT OF THE FORECARRIAGE

Carefully read 0.5.1 (PRECAUTIONS AND GENERAL INFORMATIONS).

- ◆ Position the vehicle on the special centre stand, see 1.8.4 (POSITIONING THE VEHICLE ON THE CENTRE SUPPORT STAND **OPT**).

NOTE Procure suitable shims to place between the front tyre and the support (1).
The number of shims depends on the desired riding position (maximum number: six, like the number of possible variations, 4 mm at a time).

Thickness for each element: 4 mm.

- ◆ Place a support (1) under the front tyre so as to keep the forecarriage in place once it is released.
- ◆ ★ Loosen the two screws (2) securing the lower plate (3) to the slider (4).

Screws (2) driving torque: 25 Nm (2.5 kgm).

- ◆ ★ Loosen the screw (5) securing the upper plate (6) to the slider (4).

Screw (5) driving torque: 25 Nm (2.5 kgm).

- ◆ ★ Loosen the screw (7) securing the handlebar (8) to the slider (4).

Screw (7) driving torque: 25 Nm (2.5 kgm).

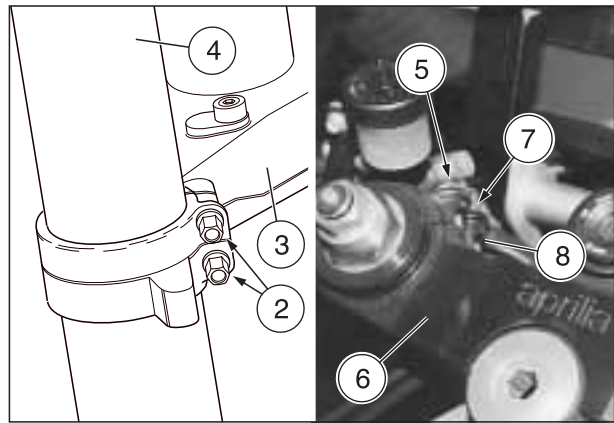
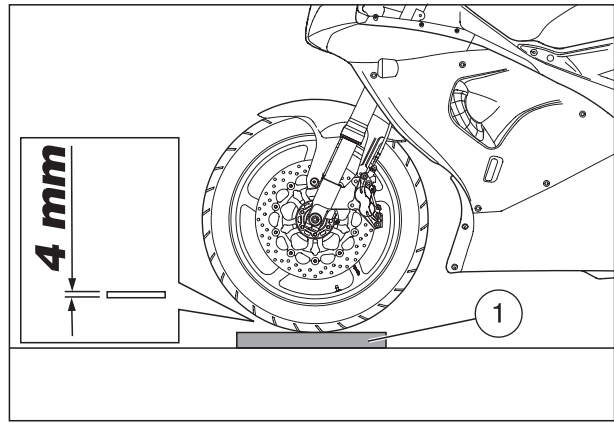

⚠ CAUTION

Due to the weight of the forecarriage, the following operations require the assistance of another operator.

Fix the operating procedure before starting work.
The removal must be carried out with the greatest care.

- ◆ Grip the forecarriage firmly and lift it slightly in the direction in which the sliders (4) are inserted on the two fastening plates (3) (6).
- ◆ Place one or more of the shims between the tyre and the support (1) depending on the desired variation.
- ◆ Release the forecarriage.

NOTE There are six notches to be found in the upper part of each fork slider, to be used as reference for the six different positions possible (see figure).

- ◆ Make sure the notch in the fork sliders which the upper plate is lined up with corresponds to the desired variation.

⚠ CAUTION

The upper plate must be lined up with the same reference notch on both fork sliders.

Any variation, whether up or down, must always be made in the range between the first reference notch and the last.

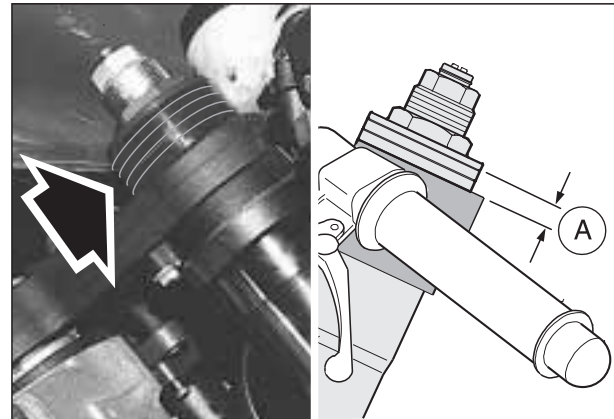

Front suspension	Standard adjustment	Adjustment for racetrack use	Possible adjustments
Protrusion of the rods (A) from the upper plate (plug excluded)	8 mm (2 notches)	12 mm (3 notches)	2 - 4 notches
	RSV 01 4 reference notches	RSV 01 4 reference notches	RSV 01 2 - 4 reference notches

2.30 REAR FORK

Carefully read 0.5.1 (PRECAUTIONS AND GENERAL INFORMATIONS).

Rear fork bearings and rear fork slack:

for the maintenance intervals, see 2.1.1 (REGULAR SERVICE INTERVALS CHART).

For the check, proceed as follows:

- ◆ Position the vehicle on the special centre stand, see 1.8.4 (POSITIONING THE VEHICLE ON THE CENTRE SUPPORT STAND **OPT**).
- ◆ Shake the fork in the direction of travel (see figure). If you find any slack, adjust the rear fork, see 2.30.1 (ADJUSTING THE REAR FORK). If the slack persists, adjust the bearings, see 7.9.6 (DISASSEMBLING THE REAR FORK GASKETS).

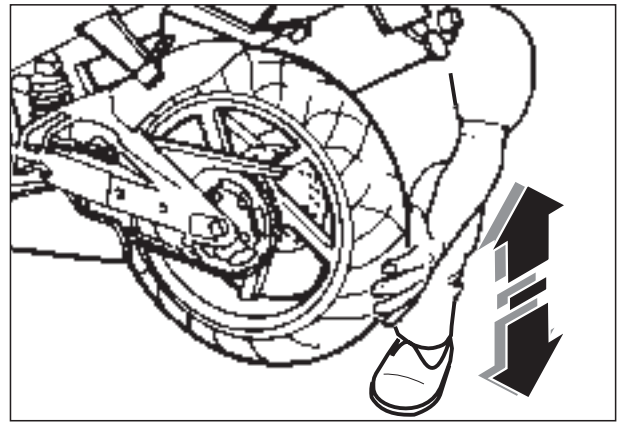

2.30.1 ADJUSTING THE REAR FORK

Carefully read 0.5.1 (PRECAUTIONS AND GENERAL INFORMATIONS).

- ◆ Position the vehicle on the special centre stand, see 1.8.4 (POSITIONING THE VEHICLE ON THE CENTRE SUPPORT STAND **OPT**).
- ◆ Loosen the nut (1) completely.

NOTE Have the appropriate special tool **OPT** to hand:
– **aprilia** part# 8140203 (complete tool kit for frame including).

- ◆ Use the special setscrew spanner to loosen the lock ring (2) completely.
- ◆ Working from the right-hand side of the vehicle, rotate the fork pin (3) clockwise, which will cause the bush (4) to rotate with it, in turn pushing the fork to its stop.

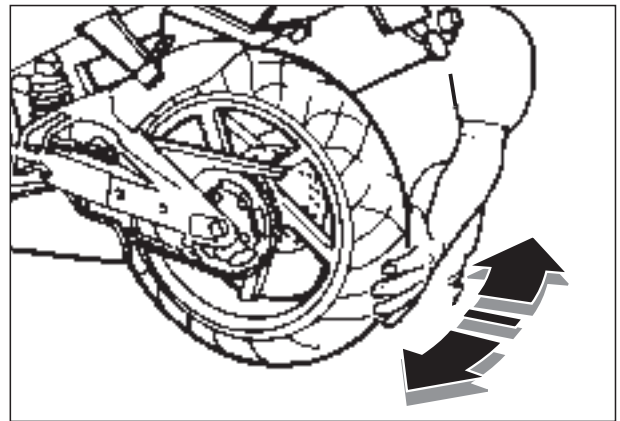

Driving torque to be applied on the pin (3): 12 Nm (1.2 kgm).

- ◆ Use the special setscrew spanner to tighten the lock ring (2).

Lock ring (2) driving torque: 60 Nm (6.0 kgm).

- ◆ Tighten the nut (1).

Nut (1) driving torque: 90 Nm (9.0 kgm).

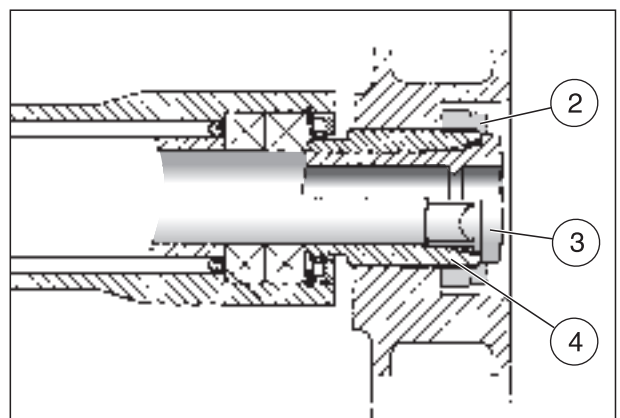
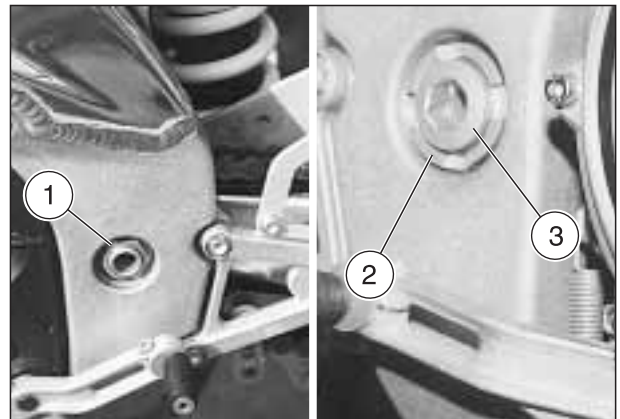

**2.31 INSPECTING THE REAR SUSPENSION
(models up to 2001)**

2.31.1 REAR SUSPENSION

The rear suspension consists of a spring-shock absorber unit, fixed to the frame by means of a uni-ball and to the rear fork by means of lever systems.

For the setting of the vehicle attitude, the shock absorber is provided with a screw adjuster (1) for the adjustment of the hydraulic braking with extended shock absorber; a knob adjuster (2) for the adjustment of the hydraulic braking with compressed shock absorber; a ring nut for the adjustment of the spring preload (3) and a locking ring nut (4).

The riding position of the vehicle can be further altered by varying the height of the rear axle by adjusting the lock nut (5) and adjuster nut (6).

Carefully read 0.5.1 (PRECAUTIONS AND GENERAL INFORMATIONS).

Rear shock absorber:

for the maintenance intervals, see 2.1.1 (REGULAR SERVICE INTERVALS CHART).

- ◆ Check all the rear suspension joints are working properly and that the relevant components are properly tightened.

2.31.2 ADJUSTING THE REAR SHOCK ABSORBER

The standard setting of the rear shock absorber is such as to satisfy most driving conditions at low and high speed, either with reduced load and full load.

However, it is possible to adjust the setting according to how the vehicle is going to be used.

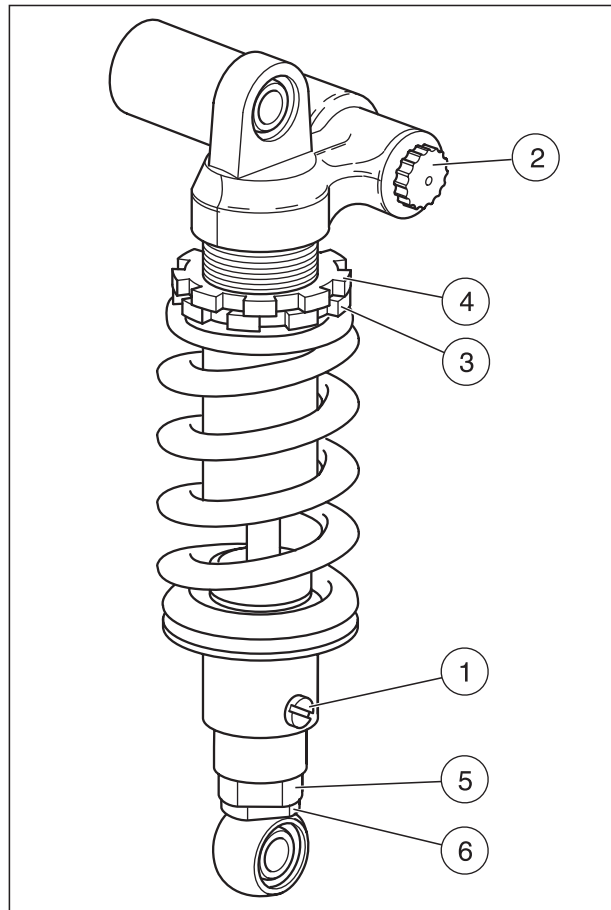

⚠ CAUTION

For the adjustment, always start from the most rigid setting; screw adjuster (1) and knob adjuster (2) completely rotated clockwise.

Do not rotate the screw adjuster (1) beyond its limit position, to avoid damaging the thread.

Make sure that the screw adjuster (1) always snaps and is not in any intermediate position.

- ◆ Slightly unscrew the locking ring nut (4) by means of the appropriate spanner.
- ◆ Act on the adjusting ring nut (3) (shock absorber spring preload adjustment) (see figure).
- ◆ After the adjustment, tighten the metal ring (4).
- ◆ Adjust the hydraulic braking with extended shock absorber by means of the screw (1) (see table).
- ◆ Adjust the knob (2) to adjust the hydraulic braking with compressed shock absorber (see table).

To vary the attitude of the vehicle, proceed as follows:

- ◆ Moderately loosen the lock nut (5).

NOTE Rotate the adjuster (6) by giving it one turn at a time, so that the adjusting screw (1) is always on the left side of the vehicle.

- ◆ Act on the adjuster (6) (see table).

⚠ CAUTION

The lock nut (5) must be tightened with the indicated driving torque.

- ◆ After the adjustment, tighten the lock nut (5).

Lock nut (5) driving torque: 40 Nm (4.0 kgm).

Follow ►



Follow ►

CAUTION

Adjust the spring preload and the hydraulic braking with extended shock absorber according to the conditions of use of the vehicle.

When the spring preload is increased, it is necessary to increase also the hydraulic braking with extended shock absorber, in order to avoid sudden jerks while riding.

Turn the screw adjuster (1) 2-3 clicks at a time, the knob adjuster (2) 5-6 clicks at a time and the adjusting ring nut (3) one turn at a time.

Test the vehicle repeatedly on the road, until obtaining the optimal adjustment.

To avoid affecting the operation of the shock absorber, neither remove the plug (7), nor adjust the underlying valve, since this may cause nitrogen to flow out, with consequent risk of accidents.

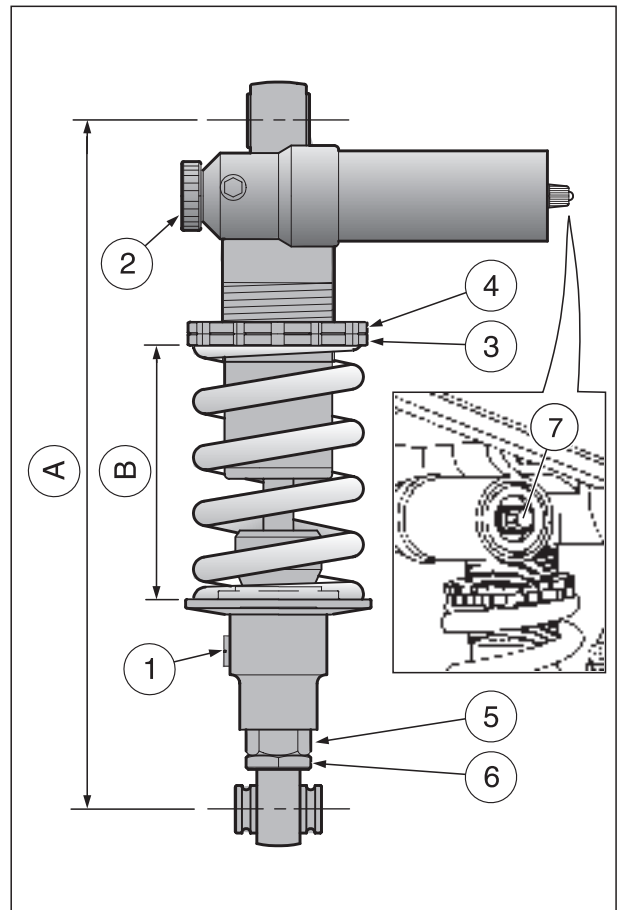

Rear suspension	Standard adjustment	Adjustment for race-track use	Possible adjustments
Shock absorber distance between centers (A)	322 ± 1 mm	322 ± 1 mm	from 320 to 327 mm
Spring length (preloaded) (B)	130 mm	128 mm	from 128 to 132 mm
Adjustment with extended shock absorber, screw (1)	from completely closed (*) open giving 14 clicks (**)	from completely closed (*) open giving 7-9 clicks (**)	completely open: 25 clicks
Adjustment with compressed shock absorber, knob (2)	from completely closed (*) open giving 45 clicks (**)	from completely closed (*) open giving 20-30 clicks (**)	completely open: 45 clicks

(*) = clockwise
 (**) = anticlockwise

2.32 INSPECTING THE REAR SUSPENSION

RSV 01

2.32.1 REAR SUSPENSION

The rear suspension consists of a spring-shock absorber unit, fixed to the frame by means of a uni-ball and to the rear fork by means of lever systems.

For the adjustment of the setting, the shock absorber is provided with a ring nut adjuster (1) for the hydraulic braking with extended shock absorber, with a knob adjuster (2) for the hydraulic braking with compressed shock absorber, with a ring nut for the spring preload (3) and with a locking ring nut (4).

It is possible to adjust the height of the rear part of the vehicle, to personalize the attitude of the vehicle itself.

Carefully read 0.5.1 (PRECAUTIONS AND GENERAL INFORMATIONS).

Rear shock absorber:

for the maintenance intervals, see 2.1.1 (REGULAR SERVICE INTERVALS CHART).

- ◆ Check all the rear suspension joints are working properly and that the relevant components are properly tightened.

2.32.2 ADJUSTING THE REAR SHOCK ABSORBER

The standard setting of the rear shock absorber is adjusted in such a way as to be suitable for racetrack riding. However, it is possible to adjust the setting according to how the vehicle is going to be used.

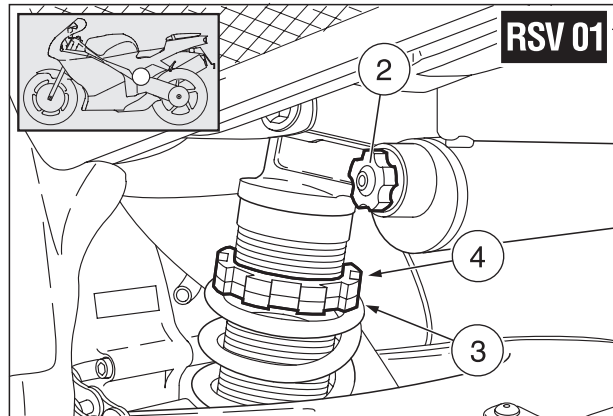
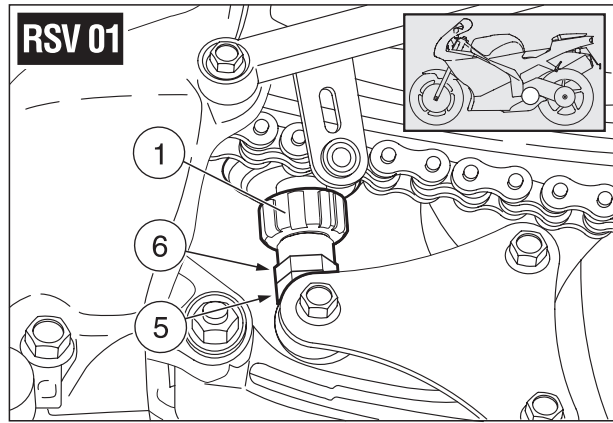

⚠ CAUTION

To calculate the number of clicks of the adjusters (1-2), always start from the most rigid setting (complete clockwise rotation of the adjuster).

Do not force the rotation of the adjusters (1-2) beyond the end of stroke in both directions, in order to avoid any damage.

- ◆ Unscrew the lock metal ring (4) by means of the appropriate spanner.
- ◆ Adjust the preload of the spring (B) through the adjusting ring nut (3) (see table).
- ◆ After the adjustment, tighten the metal ring (4).
- ◆ Adjust the metal ring (1) to adjust the hydraulic braking with extended shock absorber (see table).
- ◆ Adjust the knob (2) to adjust the hydraulic braking with compressed shock absorber (see table).

To vary the attitude of the vehicle, proceed as follows:

- ◆ Moderately loosen the lock nut (5).
- ◆ Adjust the shock absorber length (distance between centres) (6) through the adjuster (A) (see table).

⚠ CAUTION

The lock nut (5) must be tightened with the indicated driving torque.

- ◆ After the adjustment, tighten the lock nut (5).

Lock nut (5) driving torque: 40 Nm (4 kgm).

Follow ►



Follow ►

CAUTION

Adjust the spring preload and the hydraulic braking with extended shock absorber according to the conditions of use of the vehicle.

When the spring preload is increased, it is necessary to increase also the hydraulic braking with extended shock absorber, in order to avoid sudden jerks while riding.

In order not to affect the operation of the shock absorber, it is absolutely forbidden to loosen or remove the screw (7), since this may cause the outflow of nitrogen with the consequent risk of serious accidents.

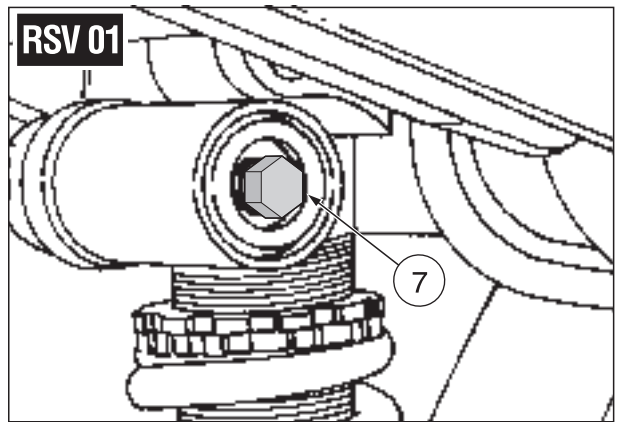
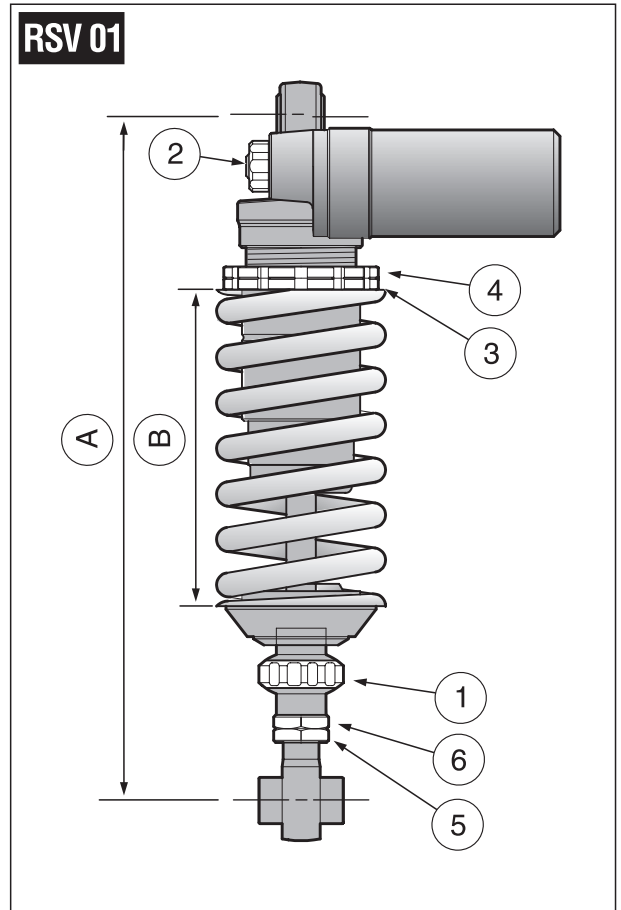

Rear suspension	Standard adjustment	Adjustment for racetrack use
Shock absorber distance between centers (A)	321 ±1.5 mm	from 321 to 323 mm
Spring length (preloaded) (B)	147 mm	145 mm
Adjustment with extended shock absorber, metal ring (1)	from completely closed (*) open (**) giving 20 clicks	from completely closed (*) open (**) giving 12 – 16 clicks
Adjustment with compressed shock absorber, knob (2)	from completely closed (*) open (**) giving 12 clicks	from completely closed (*) open (**) giving 8 – 14 clicks

(*) = clockwise

(**) = anticlockwise

2.32.3 CHECKING THE REAR SUSPENSION LINKAGE

Carefully read 0.5.1 (PRECAUTIONS AND GENERAL INFORMATIONS).

Rear suspension linkage bearings:

for the maintenance intervals, see 2.1.1 (REGULAR SERVICE INTERVALS CHART).

For the check, proceed as follows:

NOTE Have someone help you keep the vehicle up-right during this operation.

- ◆ Grip the rear part of the vehicle firmly (see figure), press down and release a few times.
- ◆ If the movement is not smooth and is accompanied by squeaks and/or if you notice any slack, change the bearings of the rear suspension linkage, see 7.10.4 (DISASSEMBLING THE REAR SUSPENSION LINKAGE).
- ◆ If, after you pressed the vehicle downwards, it returns to its original position very slowly, check if the rear suspension is adjusted correctly, see 2.31.2 (ADJUSTING THE REAR SHOCK ABSORBER).
- ◆ If, after the adjustment, the defect persists, this means that the shock absorber bumps through and must therefore be reloaded.

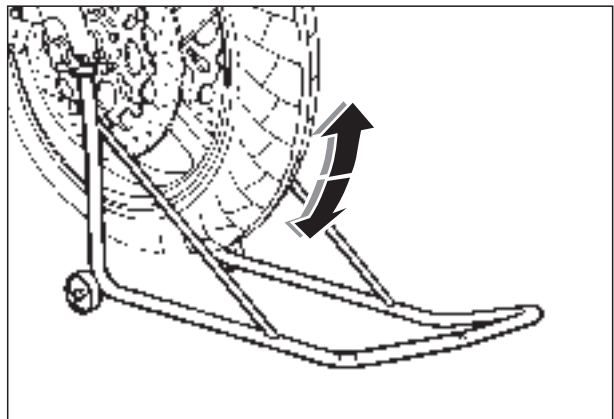
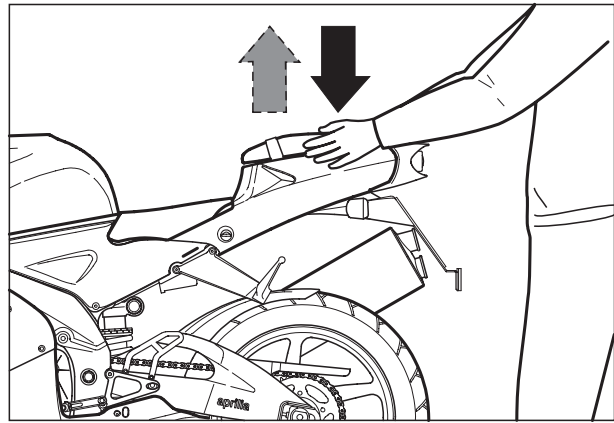

2.33 FRONT WHEEL

Carefully read 0.5.1 (PRECAUTIONS AND GENERAL INFORMATIONS).

Wheel bearings:

for the maintenance intervals, see 2.1.1 (REGULAR SERVICE INTERVALS CHART).

For the check, proceed as follows:

- ◆ Position the vehicle on the special front support stand **OPT**.
- ◆ Spin the wheel in either direction by hand.
- ◆ Make sure that the wheel rotation is regular and that there are no obstacles or noise, otherwise change the bearings, see 7.2.9 (DISASSEMBLING THE FRONT WHEEL BEARINGS).
- ◆ Should any wobbling be noticed as the wheel spins, check the relevant components, see 7.2.2 (CHECKING THE FRONT WHEEL COMPONENTS).
- ◆ If, after various spins, the wheel continues to stop in the same place, the wheel needs balancing.



2.34 REAR WHEEL

Carefully read 0.5.1 (PRECAUTIONS AND GENERAL INFORMATIONS).

Wheel bearings:

for the maintenance intervals, see 2.1.1 (REGULAR SERVICE INTERVALS CHART).

For the check, proceed as follows:

- ◆ Position the vehicle on the appropriate rear support stand, see 1.8.2 (POSITIONING THE VEHICLE ON THE REAR SUPPORT STAND **OPT**).
- ◆ Spin the wheel in either direction by hand.
- ◆ Make sure that the wheel rotation is regular and that there are no obstacles or noise, otherwise change the bearings, see 7.2.9 (DISASSEMBLING THE FRONT WHEEL BEARINGS).
- ◆ Should any wobbling be noticed as the wheel spins, check the relevant components, see 7.2.2 (CHECKING THE FRONT WHEEL COMPONENTS).
- ◆ If, after various spins, the wheel continues to stop in the same place, the wheel needs balancing.

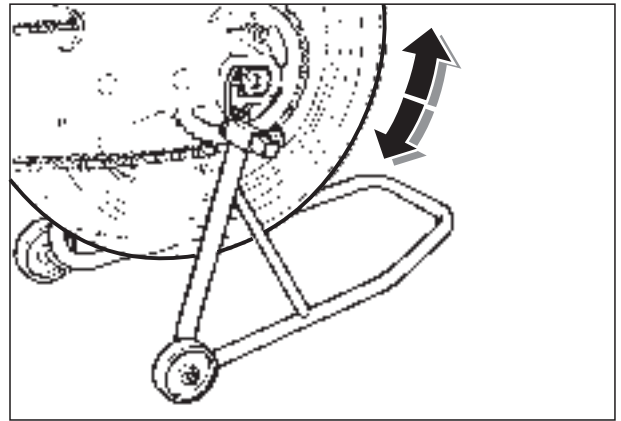

2.35 EXHAUST MANIFOLD NUTS

Carefully read 0.5.1 (PRECAUTIONS AND GENERAL INFORMATIONS).

Nut, bolt, screw tightening:

for the maintenance intervals, see 2.1.1 (REGULAR SERVICE INTERVALS CHART).

For the tightening:

⚠ WARNING

Let the engine cool down until it reaches room temperature.

- ◆ Remove the side fairings, see 7.1.28 (REMOVING THE SIDE FAIRINGS).
- ◆ Remove the front grille, see 7.1.35 (REMOVING THE RADIATOR SPOILER).
- ◆ Torque the three nuts (1) of the front cylinder exhaust manifold to specification.
- ◆ Torque the three nuts (2) of the rear cylinder exhaust manifold to specification.

Nuts driving torque: 25 Nm (2.5 kgm).

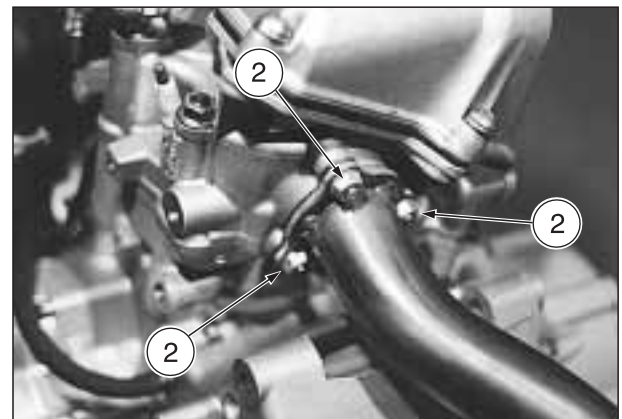
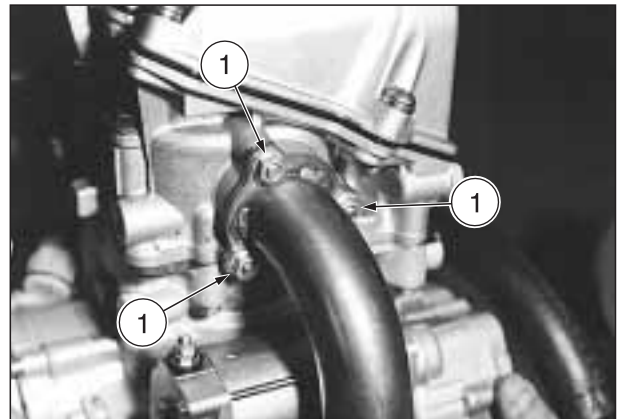

2.36 DRIVE CHAIN

Carefully read 0.5.1 (PRECAUTIONS AND GENERAL INFORMATIONS).

Drive chain tension and lubrication, drive final transmission (chain, crown, pinion):

for the maintenance intervals, see 2.1.1 (REGULAR SERVICE INTERVALS CHART).

The vehicle is equipped with an endless chain, in which a ring link joint is not used.

Chain type: see 1.5 (TECHNICAL SPECIFICATIONS).

⚠ CAUTION

The drive chain is provided with O rings among the links, in order to keep the grease inside them.

Carry out the adjustment, lubrication, cleaning and change of the chain with great care.

- ◆ Position the vehicle on the appropriate rear support stand, see 1.8.2 (POSITIONING THE VEHICLE ON THE REAR SUPPORT STAND **OPT**).
- ◆ Position the gear lever in neutral.
- ◆ Turn the rear wheel slowly by hand.
- ◆ Further, check the chain and sprockets and make sure that they do not present:
 - damaged rollers;
 - loose pins;
 - dry, rusty, crushed or seized links;
 - excessive wear;
 - lacking O rings;
 - sprocket or teeth excessively worn or damaged.

⚠ CAUTION

If the chain rollers are damaged, the pins are loose and/or the O rings are damaged or lacking, it is necessary to change the whole chain unit (both sprockets and chain), see 7.3.2 (REMOVING THE FINAL DRIVE UNIT).

2.36.1 CHECKING THE DRIVE CHAIN SLACK

To check the slack, proceed as follows:

- ◆ Position the vehicle on the appropriate rear support stand, see 1.8.2 (POSITIONING THE VEHICLE ON THE REAR SUPPORT STAND **OPT**).
- ◆ Position the gear lever in neutral.
- ◆ Make sure that the vertical oscillation, in an intermediate point between pinion and crown in the lower part of the chain, is about **25 mm**.
- ◆ Rotate the rear wheel manually, in such a way as to check the vertical oscillation of the chain even in other positions; the slack must be constant in all the wheel rotation phases.

⚠ CAUTION

If in some positions the slack is higher than in others, this means that there are crushed or seized links.

To prevent the risk of seizures, lubricate the chain frequently, see 2.36.4 (DRIVE CHAIN TENSION AND LUBRICATION).

If the slack is uniform, but higher or lower than **25 mm**, adjust it, see 2.36.3 (ADJUSTING THE DRIVING CHAIN).

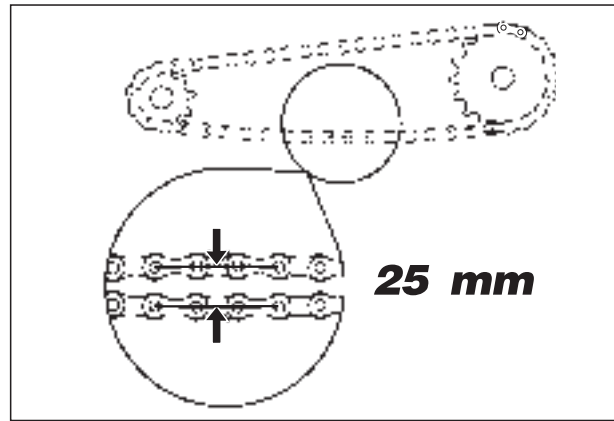

⚠ CAUTION

An excessive slackening of the chain may cause noise or make the chain rattle, with consequent wear of the shoe and of the chain guide plate.

Incorrect maintenance may cause the untimely wear of the chain and/or damages to the pinion and/or the crown.

Carry out the maintenance operations more frequently if you use the vehicle in difficult conditions or on dusty and/or muddy roads.

2.36.2 CHECKING THE DRIVING CHAIN, PINION AND SPROCKET WEAR

- ◆ To put a driving chain under tension, see 2.36.3 (ADJUSTING THE DRIVING CHAIN).
- ◆ Count 17 pins (16 steps) on a branch of the chain and measure the distance between the two end pins.
If the distance is larger than the limit indicated below, replace the chain, see 7.11 (DISASSEMBLING THE DRIVING CHAIN).

Wear limit: 255.5 mm (MAX 0.5%).

2.36.3 ADJUSTING THE DRIVING CHAIN

If after the check it is necessary to adjust the chain tension, proceed as follows:

- ◆ Position the vehicle on the appropriate rear support stand, see 1.8.2 (POSITIONING THE VEHICLE ON THE REAR SUPPORT STAND **OPT**).
- ◆ Loosen the nut (1).

NOTE For the wheel centering fixed reference marks (2) (3) are provided, which can be seen inside the chain tightener seats on the rear fork arms, before the wheel pin.

- ◆ Loosen the two lock nuts (4).
- ◆ Act on the adjusters (5) and adjust the chain slack, making sure that the reference marks (2) (3) are correctly positioned on both sides of the vehicle.
- ◆ Tighten the two lock nuts (4).
- ◆ Tighten the nut (1).

Wheel nut driving torque: 120 Nm (12.0 kgm).

- ◆ Check the chain slack, see 2.36.1 (CHECKING THE DRIVE CHAIN SLACK).

2.36.4 DRIVE CHAIN TENSION AND LUBRICATION

Drive chain tension and lubrication, drive final transmission (chain, crown, pinion):

for the maintenance intervals, see 2.1.1 (REGULAR SERVICE INTERVALS CHART).

Never wash the chain with water jets, steam jets, high-pressure water jets and highly inflammable solvents.

- ◆ Wash the chain with naphtha or kerosene.
If it tends to rust quickly, intensify the maintenance intervals.

CAUTION

Do not use trichloroethylene, petrol, or other similar liquids: their dissolving power may be excessive for this chain and, even more important, they are liable to damage the O-rings that hold the grease in the gaps between the rollers and the pins.

- ◆ After washing the chain and letting it dry, lubricate it with spray grease for chains provided with sealing rings, see 1.6 (LUBRICANT CHART).

NOTE Do not use the vehicle soon after lubricating the chain, since due to the centrifugal force the lubricant would be sprayed outwards and dirty the surrounding areas.

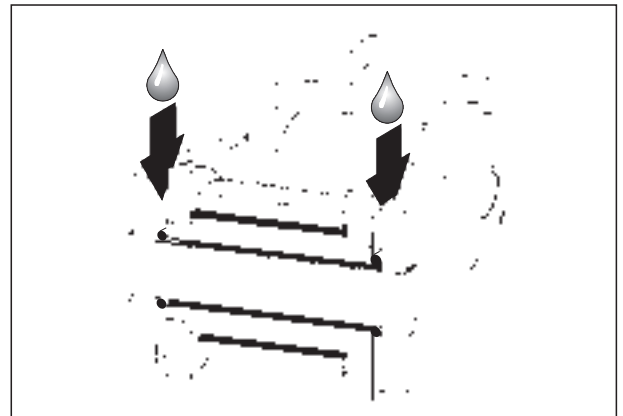
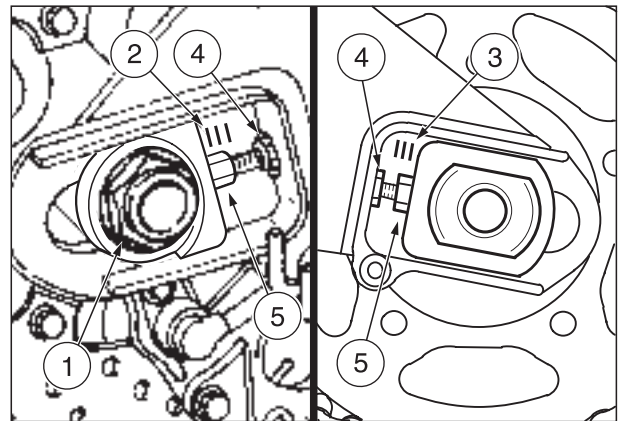
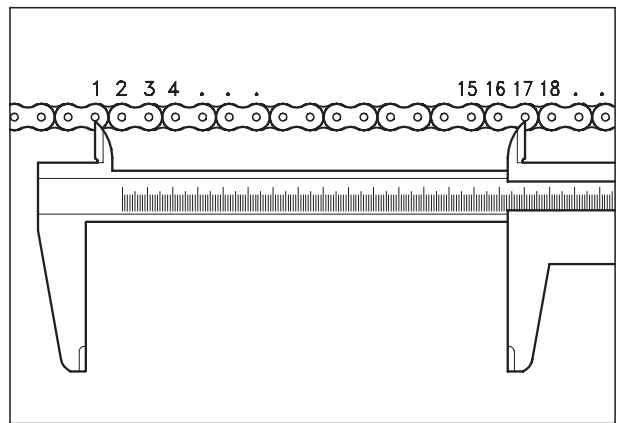

CAUTION

The lubricants for chains available on the market may contain substances that are dangerous for the rubber sealing rings of the chain.

For the replacement it is advisable to use a chain of the same type, see 1.5 (TECHNICAL SPECIFICATIONS).

2.36.5 INSPECTING THE DRIVING CHAIN GUIDE PLATE

Carefully read 0.5.1 (PRECAUTIONS AND GENERAL INFORMATIONS).

- ◆ Position the vehicle on the stand.
- ◆ Remove the lower fairing, see 7.1.34 (REMOVING THE LOWER FAIRING).
- ◆ Remove the gearshift lever, see 3.2.2 (REMOVING THE GEAR LEVER).
- ◆ Remove the clutch control cylinder, see 3.2.3 (REMOVING THE CLUTCH CONTROL CYLINDER).
- ◆ Unscrew and remove the three screws (1).

Screws (1) driving torque: 12 Nm (1.2 kgm).

NOTE Release the cable of the side stand switch from the clip.

- ◆ Remove the pinion protection case (2).
- ◆ Remove the guide plate (3).
- ◆ Make sure the guide plate (3) is not worn or damaged; if so, replace with a new one.

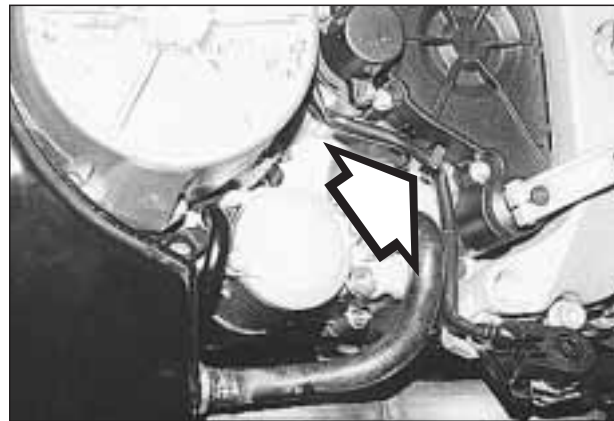
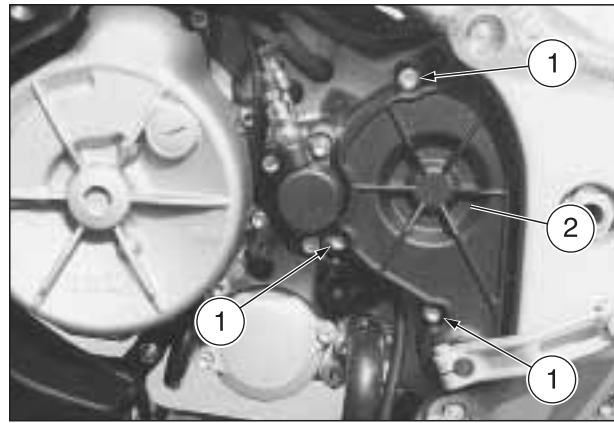

2.36.6 INSPECTING THE DRIVING CHAIN SHOE

- ◆ Position the vehicle on the stand.
- ◆ Make sure the shoe (4) is not worn or damaged; if so, replace with a new one, see 7.1.54 (REMOVING THE DRIVING CHAIN SHOE).
- ◆ Check the wear of the chain plastic guide (5).

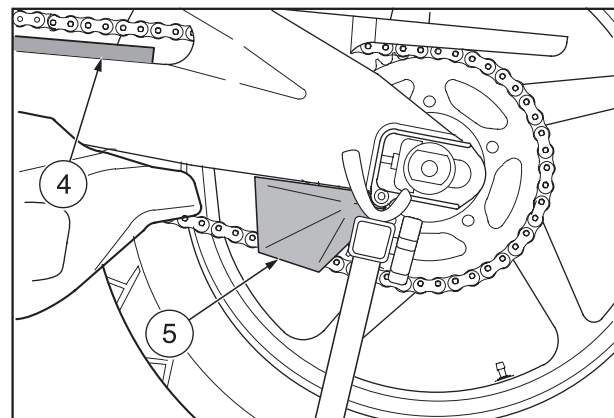
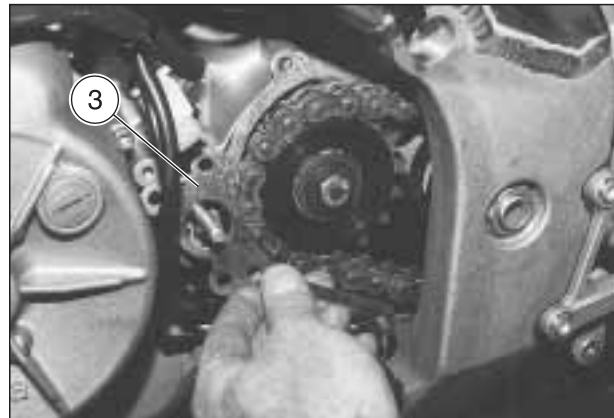

2.37 TYRES

Carefully read 0.5.1 (PRECAUTIONS AND GENERAL INFORMATIONS).

Tyres, tyre pressure, wheels/tyres:

for the maintenance intervals, see 2.1.1 (REGULAR SERVICE INTERVALS CHART).

This vehicle is provided with tubeless tyres.

2.37.1 CONDITION OF TREAD**⚠ CAUTION**

Check the surface and the wear of the tyres, since tyres in bad conditions can impair both the grip and the controllability of the vehicle.

Change the tyre when it is worn out or in case of puncture on the tread side, if the puncture is larger than 5 mm.

Some types of tyres homologated for this vehicle are provided with wear indicators.

There are several kinds of wear indicators.

For more information on how to check the wear, contact your Dealer.

Do not install tyres with air tube on rims for tubeless tyres and viceversa.

Make sure that the inflation valves (1) always have their sealing caps on, to prevent the tyres from suddenly going flat.

Change, repair, maintenance and balancing operations are very important and therefore they must be performed by qualified technicians with appropriate tools.

MINIMUM TREAD DEPTH LIMIT (A):

front and rear 2 mm (USA 3 mm) and in any case not less than prescribed by the regulations in force in the country where the vehicle is used.

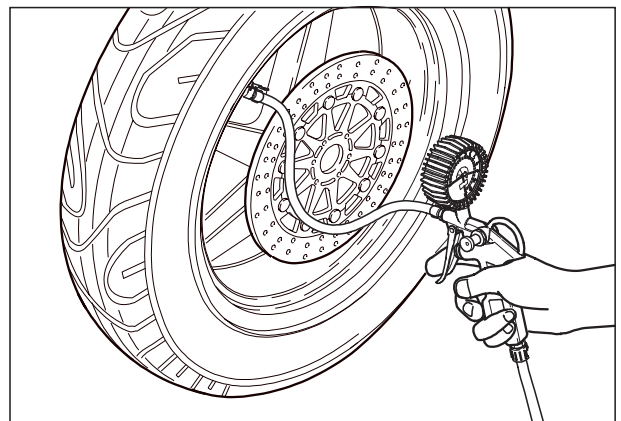
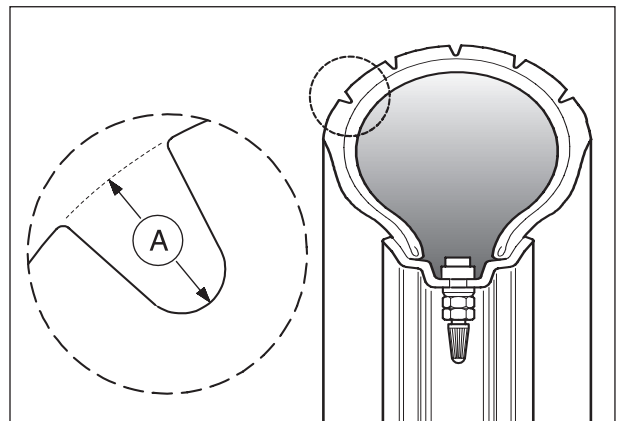
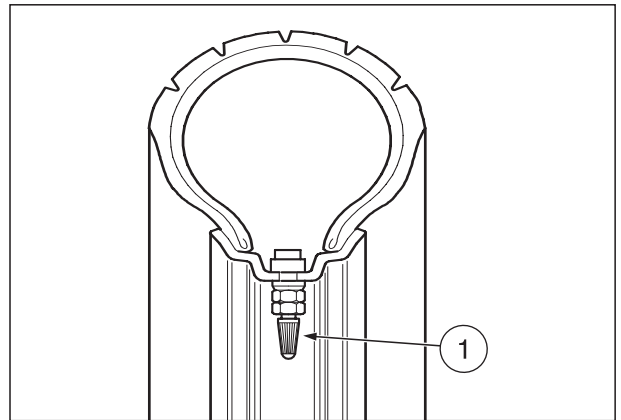

2.37.2 INFLATION PRESSURE

⚠ CAUTION

Periodically check the tyre inflation pressure at room temperature, see 1.5 (TECHNICAL SPECIFICATIONS). If the tyres are hot, the measurement is not correct. Carry out the measurement especially before and after long rides.

If the inflation pressure is too high, the ground unevenness cannot be dampened and is therefore transmitted to the handlebar, thus compromising the driving comfort and reducing the road holding during turns.

If, on the contrary, the inflation pressure is too low, the tyre sides (2) are under greater stress and the tyre itself may slip on the rim or it may become loose, with consequent loss of control of the vehicle. In case of sudden braking the tyres could even come off the rims. Further, the vehicle could skid while turning.

⚠ CAUTION

After repairing a tyre, have the wheels balanced. If the tyres are new, they may still be covered with a slippery film: drive carefully for the first miles. Do not oil the tyres with unsuitable fluids.

⚠ CAUTION

The size of the tyres is indicated in the log-book and any dissimilarity is punishable by law.

Using tyres with different dimensions may cause the instability of the vehicle, endangering its driving safety and manoeuvrability.

Use only tyres recommended by **aprilia**, see 1.5 (TECHNICAL SPECIFICATIONS).

For further information, see 7.4 (TYRES).

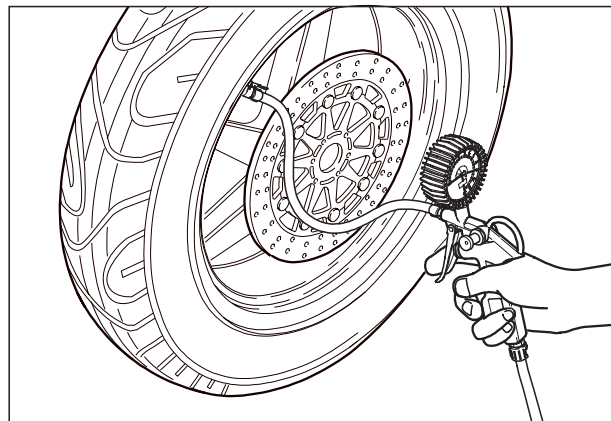
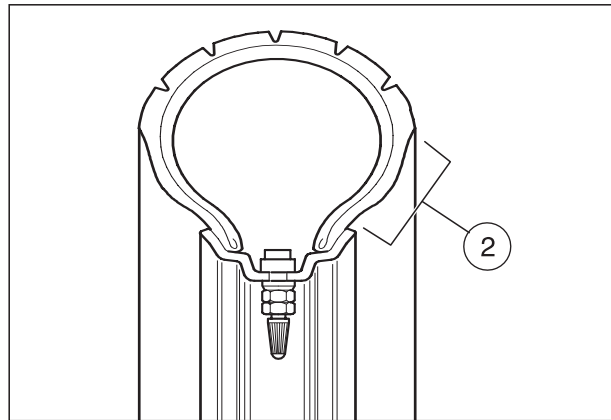

2.38 FUEL PIPES

Carefully read 1.2.1 (FUEL).

Fuel pipes:

for the maintenance intervals, see 2.1.1 (REGULAR SERVICE INTERVALS CHART).

If you should encounter signs of wear, cracking, etc., replace the fuel pipes.

- High-pressure delivery pipe [~ 450 kpa (4.5 bar)].
- Return pipe (2).

NOTE Make sure the male quick coupling (3) has been correctly inserted into the receptacle (4).

For further information, see section 4 (FUEL SUPPLY SYSTEM).

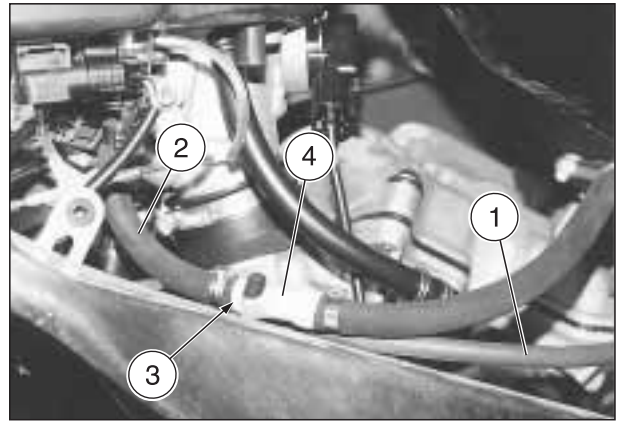

2.39 BRAKE AND CLUTCH PIPES

Carefully read 1.2.4 (BRAKE FLUID) and 1.2.6 (CLUTCH FLUID).

Brakes and clutch pipes:

for the maintenance intervals, see 2.1.1 (REGULAR SERVICE INTERVALS CHART).

If you should encounter signs of wear, cracking, etc., replace the pipes.

2.40 COOLING SYSTEM PIPES

Carefully read 1.2.5 (COOLANT).

Cooling system pipes:

for the maintenance intervals, see 2.1.1 (REGULAR SERVICE INTERVALS CHART).

If you should encounter signs of wear, cracking, etc., replace the cooling system pipes.

2.41 CHECKING THE SIDE STAND

Carefully read 0.5.1 (PRECAUTIONS AND GENERAL INFORMATIONS).

Stand:

for the maintenance intervals, see 2.1.1 (REGULAR SERVICE INTERVALS CHART).

The side stand (1) has two positions:

- normal or lifted (**Pos.A**);
- extended (**Pos.B**).

The side stand (1) must rotate without hindrances.

The springs (2) provide for keeping the stand in the desired position (extended or lifted).

Carry out the following checks:

- ◆ Position the vehicle on the appropriate rear support stand, see 1.8.2 (POSITIONING THE VEHICLE ON THE REAR SUPPORT STAND **OPT**).
- ◆ The springs (2) must not be damaged, worn, rusty or weakened.
- ◆ Make sure that the stand presents no slack in either position (extended and lifted).
- ◆ Lower the stand, making sure that the springs provide for extending it completely.
- ◆ Move the stand to let it up and release it halfway to make sure that the springs provide for lifting it completely.
- ◆ The side stand must rotate freely, if necessary grease the joint, see 1.6 (LUBRICANT CHART).

⚠ WARNING

If the side stand has wrong rotation and inclination angles, when the vehicle is parked the stability of the vehicle may be affected, with the consequent risk of overturning of the vehicle itself.

- ◆ Check the angle of rotation (C) of the stand between the two positions (A) and (B).

Stand rotation angle: $109^\circ \pm 3^\circ$.

- ◆ With the stand in position (B), check its inclination angle (D) with respect to the vertical axis.

Stand inclination angle: $30^\circ \pm 3^\circ$.

The side stand (1) is provided with a safety switch (3) that has the function to prevent or interrupt the operation of the engine with the gears on and the side stand (1) down.

To check the proper functioning of the safety switch, see 6.6.4 (CHECKING THE SIDE STAND AND THE SAFETY SWITCH).

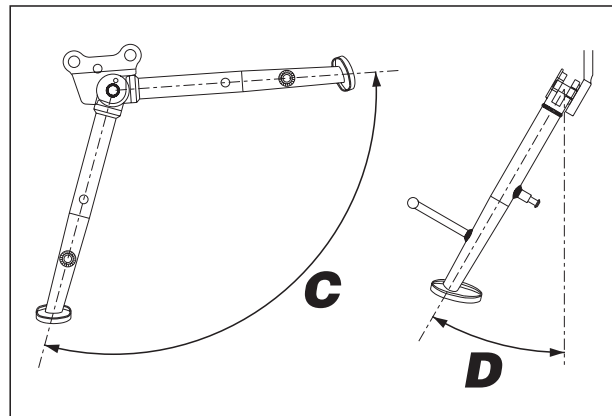
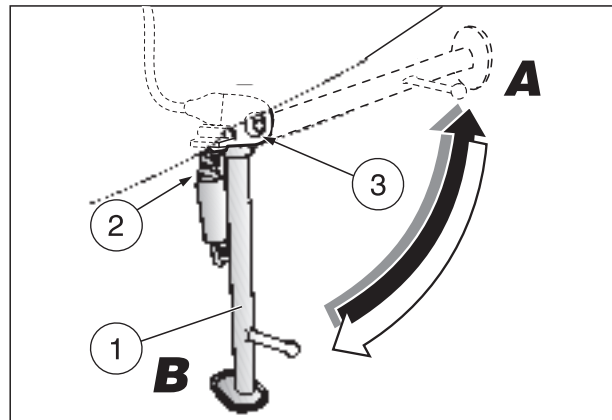

2.42 NUT, BOLT, SCREW TIGHTENING

Carefully read 0.5.1 (PRECAUTIONS AND GENERAL INFORMATIONS) and 1.10 (FASTENING ELEMENTS).

Nut, bolt, screw tightening:

for the maintenance intervals, see 2.1.1 (REGULAR SERVICE INTERVALS CHART).

Check all the fastening elements carefully, especially all those components essential for safety, i.e:

- right/left handlebar;
- front brake lever;
- clutch lever;
- fuel delivery pipe;
- front fork to plates;
- front fork / wheel pin clamps;
- front wheel;
- front brake pipe fittings front brake;
- front brake discs;
- front brake calipers;
- engine;
- pinion;
- rear brake lever;
- rear fork;
- rear fork leverage;
- rear shock absorber;
- rear wheel;
- rear brake disc;
- rear brake caliper;
- rear brake pipe fittings brake.

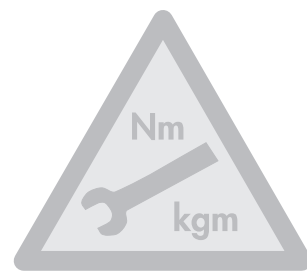

⚠ CAUTION

The fastening elements must be torqued to specification and LOCTITE® applied, where indicated, see 1.10.3 (DRIVING TORQUES).

2.43 VALVES

Adjusting the valve clearance:

for the maintenance intervals, see 2.1.1 (REGULAR SERVICE INTERVALS CHART).

To adjust the valves, refer to the engine service and repair manual, see 0.4.1 (ENGINE SERVICE AND REPAIR MANUALS).

2.44 CLUTCH

Clutch wear:

for the maintenance intervals, see 2.1.1 (REGULAR SERVICE INTERVALS CHART).

To check the clutch wear, refer to the engine service and repair manual, see 0.4.1 (ENGINE SERVICE AND REPAIR MANUALS).

2.45 PISTONS

Piston check:

for the maintenance intervals, see 2.1.1 (REGULAR SERVICE INTERVALS CHART).

To check the pistons, refer to the engine service and repair manual, see 0.4.1 (ENGINE SERVICE AND REPAIR MANUALS).

NOTES

Multiple horizontal lines for notes.

THIS PAGE HAS BEEN INTENTIONALLY LEFT EMPTY

ENGINE

3

ENGINE

TABLE OF CONTENTS

3.1 TECHNICAL INFORMATION	3-3-00
3.1.1 TECHNICAL DATA	3-3-00
3.1.2 MAINTENANCE INTERVALS	3-3-00
3.1.3 TROUBLESHOOTING	3-3-00
3.1.4 SEALANTS	3-3-00
3.1.5 LUBRICANTS	3-3-00
3.1.6 SPECIAL TOOLS	3-3-00
3.1.7 DRIVING TORQUES	3-3-00
3.1.8 PRECONDITIONS TO BE MET WHEN PERFORMING MAINTENANCE AND REPAIR WORK	3-3-00
3.1.9 GENERAL INDICATIONS ON MAINTENANCE AND REPAIR WORK ...	3-3-00
3.2 ENGINE PARTS WHICH CAN BE DISASSEMBLED WITHOUT REMOVING THE ENGINE FROM THE FRAME	3-4-00
3.2.1 REMOVING THE EXHAUST PIPES	3-6-00
3.2.2 REMOVING THE GEAR LEVER	3-7-00
3.2.3 REMOVING THE CLUTCH CONTROL CYLINDER	3-8-00
3.3 REMOVING THE WHOLE ENGINE FROM THE FRAME	3-10-00
3.3.1 POSITIONING THE ENGINE ON THE ENGINE SUPPORT STAND	3-19-00
3.4 DISASSEMBLING THE ENGINE	3-19-00
3.5 REFITTING THE WHOLE ENGINE ON THE FRAME	3-20-00
3.6 ENGINE CHECKS SUBSEQUENT TO REASSEMBLY	3-21-00
3.6.1 BLEEDING THE ENGINE OIL CIRCUIT	3-21-00
3.6.2 CHECKING THE ENGINE OIL PRESSURE	3-21-00
3.6.3 CYLINDER SYNCHRONIZATION	3-21-00

3.1 TECHNICAL INFORMATION

3.1.1 TECHNICAL DATA

See 1.5 (TECHNICAL SPECIFICATIONS).

3.1.2 MAINTENANCE INTERVALS

See 2.1.1 (REGULAR SERVICE INTERVALS CHART).

3.1.3 TROUBLESHOOTING

See 8.1 (TROUBLESHOOTING).

3.1.4 SEALANTS

See 1.9 (CONSUMABLES).

3.1.5 LUBRICANTS

See 1.6 (LUBRICANT CHART).

3.1.6 SPECIAL TOOLS

See 1.7 (SPECIAL TOOLS **OPT**).

3.1.7 DRIVING TORQUES

See 1.10 (FASTENING ELEMENTS).

3.1.8 PRECONDITIONS TO BE MET WHEN PERFORMING MAINTENANCE AND REPAIR WORK

⚠ WARNING

During the assembly phase, bear in mind the engines weight (approx. 65 kg) and centre of gravity: support accordingly.

Take care around any potentially hazardous points where you might be squashed or cut.

⚠ CAUTION

The maintenance of engines and systems calls for specific experience and the use of special tools.

Any maintenance and repair work must be performed by suitably trained technical personnel only.

NOTE Comply with the instructions furnished by the manufacturer of the vehicle.

3.1.9 GENERAL INDICATIONS ON MAINTENANCE AND REPAIR WORK

Carefully read 0.5.1 (PRECAUTIONS AND GENERAL INFORMATIONS).

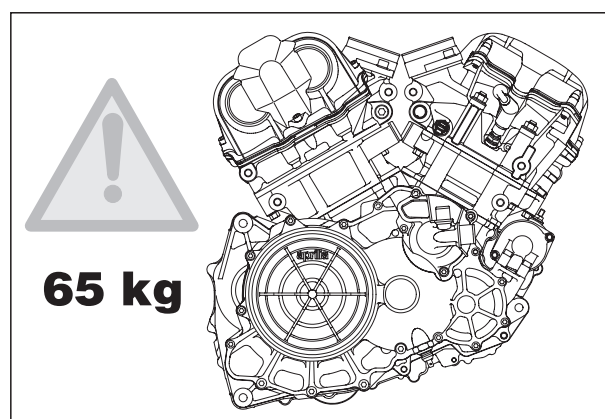
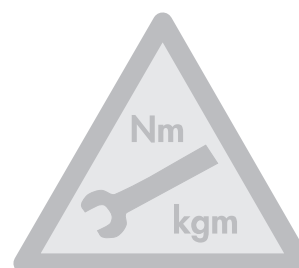

3.2 ENGINE PARTS WHICH CAN BE DISASSEMBLED WITHOUT REMOVING THE ENGINE FROM THE FRAME

Carefully read 0.5.1 (PRECAUTIONS AND GENERAL INFORMATIONS).

The parts underlined can be removed and refitted without removing the engine from the frame.

⚠ CAUTION

This chapter describes the relevant procedures progressively and in sequential order.

Any reference to operations from other chapters must be interpreted logically in order to avoid components being removed unnecessarily.

Only perform those operations necessary to remove the component in question.



TOP SIDE

- Front cylinder tappet cover (1), see 0.4.1 (ENGINE SERVICE AND REPAIR MANUALS).
- Tappet cover (2), head, cylinder and rear piston, see 0.4.1 (ENGINE SERVICE AND REPAIR MANUALS).
- Front (3) and rear (4) cylinder intake flange.
- Camshaft position sensor and camshafts, see 0.4.1 (ENGINE SERVICE AND REPAIR MANUALS).
- Front and rear cylinder timing chain tightener, see 0.4.1 (ENGINE SERVICE AND REPAIR MANUALS).



FRONT SIDE

- Front cylindrical exhaust pipe, see 3.2.1 (REMOVING THE EXHAUST PIPES).
- Starter motor (5), see 0.4.1 (ENGINE SERVICE AND REPAIR MANUALS).

REAR SIDE

- Rear cylindrical exhaust pipe, see 3.2.1 (REMOVING THE EXHAUST PIPES).

LEFT SIDE

- Rear cylinder spark plugs (6) and (7), see 2.7 (SPARK PLUGS).
- Drive pinion protection case (8), see 2.36.5 (INSPECTING THE DRIVING CHAIN GUIDE PLATE).
- Gearshift lever, see 3.2.2 (REMOVING THE GEAR LEVER).
- Rear cylinder coolant thermistor (9), see 5.5 (REMOVING THE COOLANT THERMISTORS).
- Engine oil filter (10), see 2.14 (CHANGING THE ENGINE OIL AND THE OIL FILTER).
- Neutral gear switch (11).
- Clutch control cylinder (12), see 3.2.3 (REMOVING THE CLUTCH CONTROL CYLINDER).
- Flywheel cover (13) and ignition system, see 0.4.1 (ENGINE SERVICE AND REPAIR MANUALS).
- Engine oil tank (14), see 7.1.51 (REMOVING THE ENGINE OIL TANK).
- Drive pinion (15), see 7.1.53 (REMOVING THE DRIVE PINION).
- **RST ETV** Driving shaft position sensor (22), see 0.4.1 (ENGINE SERVICE AND REPAIR MANUALS).

RIGHT SIDE

- Front cylinder coolant thermistor (16), see 5.5 (REMOVING THE COOLANT THERMISTORS).
- Front cylinder spark plugs (17) and (18), see 2.7 (SPARK PLUGS).
- Coolant pump (19), see 0.4.1 (ENGINE SERVICE AND REPAIR MANUALS).
- Engine oil pressure sensor (20).
- Clutch cover (21) and clutch assembly, 0.4.1 (ENGINE SERVICE AND REPAIR MANUALS).

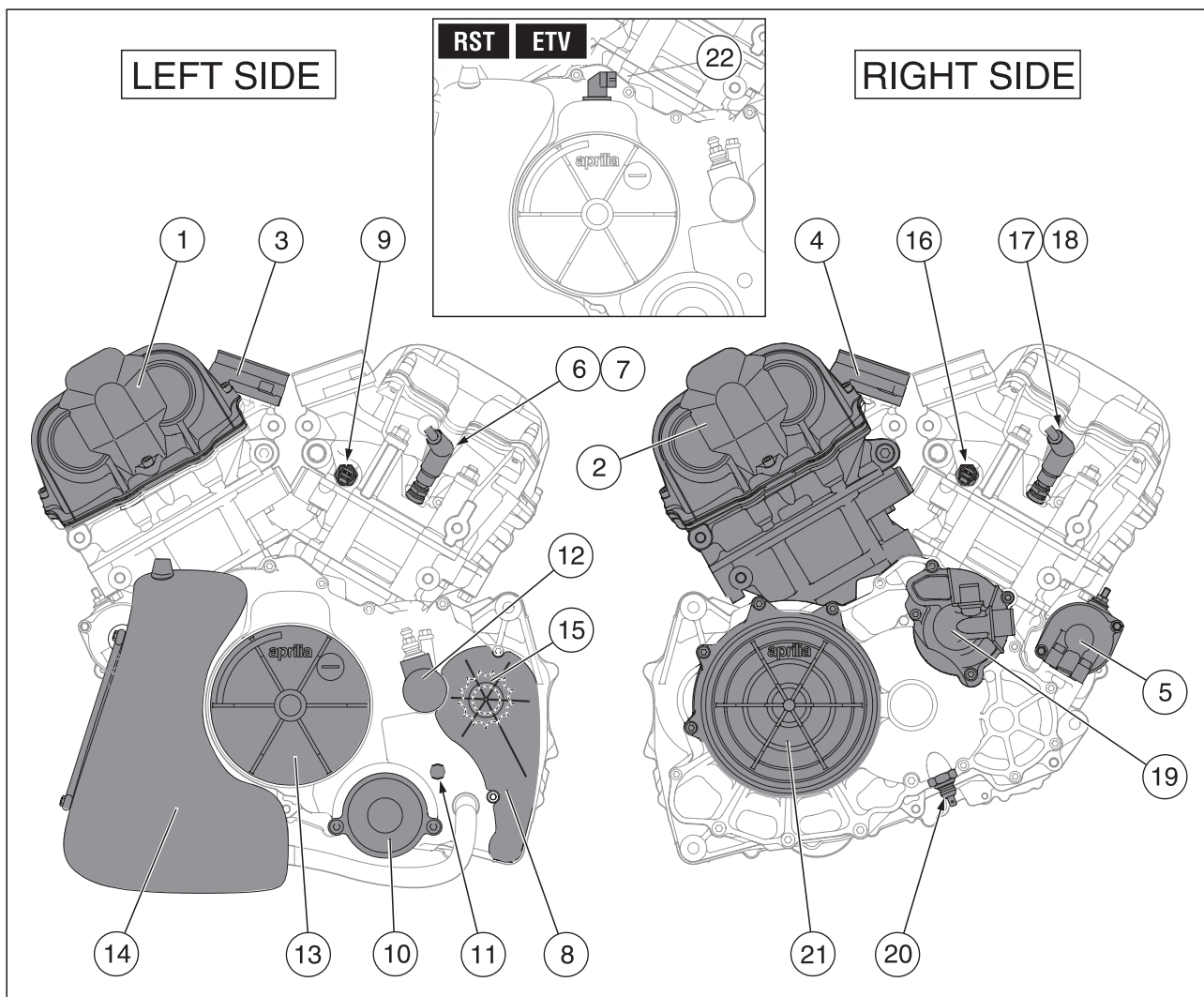

3.2.1 REMOVING THE EXHAUST PIPES

Carefully read 0.5.1 (PRECAUTIONS AND GENERAL INFORMATIONS).

⚠ WARNING

Let the engine cool down until it reaches room temperature.

- ◆ Remove the exhaust silencer, see 7.1.49 (REMOVING THE EXHAUST SILENCER).
- ◆ Remove the lower fairing, see 7.1.34 (REMOVING THE LOWER FAIRING).
- ◆ Remove the radiator spoiler, see 7.1.35 (REMOVING THE RADIATOR SPOILER).
- ◆ Unhook the two springs (1) (2) from the relevant hooks on the exhaust manifold (3).
- ◆ Remove the two springs (1) (2).

⚠ CAUTION

Check the two springs (1) (2) and, where necessary, replace them.

- ◆ Loosen and remove the three nuts (4) fastening the flange of the exhaust pipe (5) to the front cylinder.

Nuts (4) driving torque: 25 Nm (2.5 kgm).

- ◆ Loosen and remove the three nuts (6) fastening the flange of the exhaust pipe (7) to the rear cylinder.

Nuts (6) driving torque: 25 Nm (2.5 kgm).

⚠ CAUTION

When slipping the exhaust pipes (5 - 7) off the relevant cylinders, take care not to damage the thread of the fastening stud bolts.

- ◆ Move the exhaust manifold (3), together with the exhaust pipe (7), back and slightly downwards until the exhaust pipes flange is released from the stud bolts on the rear cylinder.
- ◆ Twisting gradually one way and the other, lift the exhaust pipe (7) until it slides off the exhaust manifold (3).
- ◆ Turn the exhaust pipe (7) and remove it as illustrated.

Follow ►

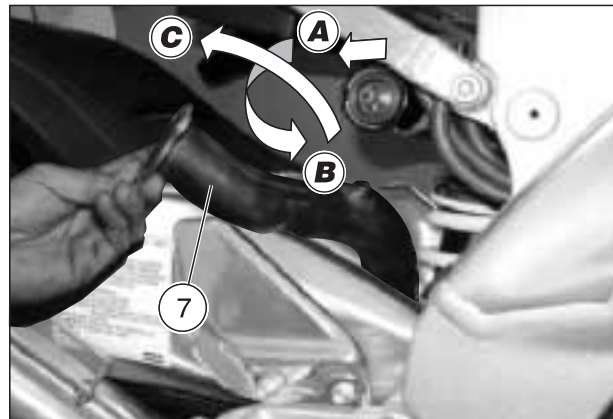
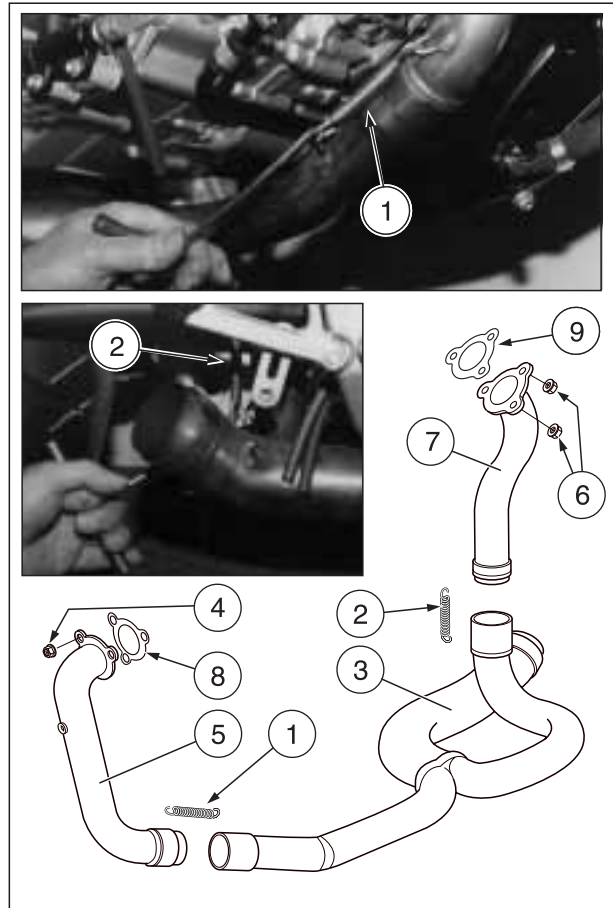

Follow ►

- ◆ Twisting gradually one way and the other, slip the exhaust manifold (3) off the exhaust pipe (5).
- ◆ Move the exhaust pipe (5) forwards until the flange is released from the stud bolts on the front cylinder.
- ◆ Turn the exhaust pipe (5) and remove it as illustrated.

⚠ CAUTION

Check and, where necessary, replace the gaskets (8) (9) with two new ones of the same type.

Plug the engines exhaust pipe openings so as to prevent any foreign bodies entering.

3.2.2 REMOVING THE GEAR LEVER

Carefully read 0.5.1 (PRECAUTIONS AND GENERAL INFORMATIONS).

⚠ CAUTION

Before removing the gearshift lever, mark its position, in order to be able to reassemble it correctly.

- ◆ Position the vehicle on the stand.
- ◆ Loosen and remove the screw (10).
- ◆ Slide the gearshift lever (11).

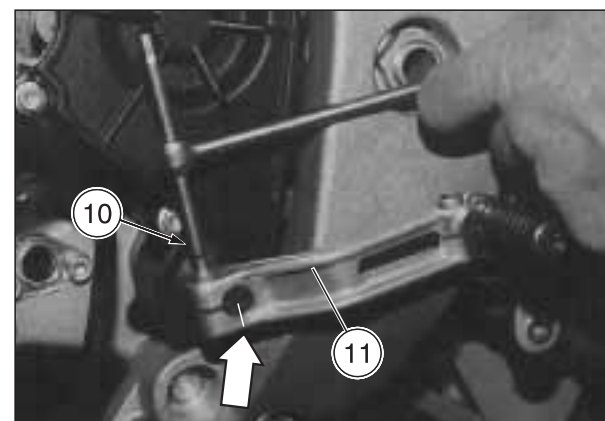
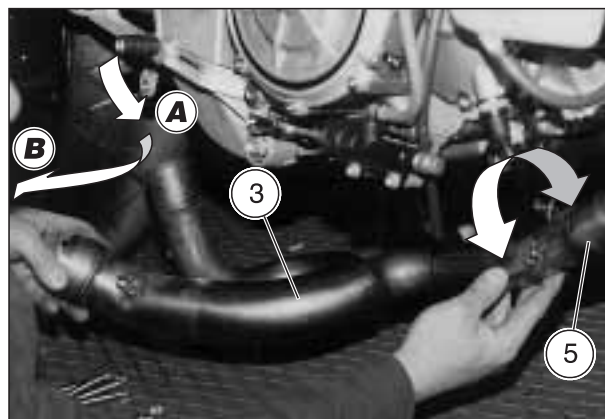
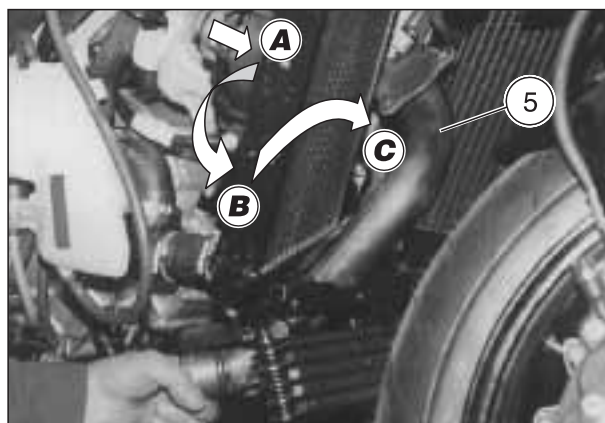

3.2.3 REMOVING THE CLUTCH CONTROL CYLINDER

Carefully read 0.5.1 (PRECAUTIONS AND GENERAL INFORMATIONS) and 1.2.6 (CLUTCH FLUID).

- ◆ Remove the left fairing, see 7.1.28 (REMOVING THE SIDE FAIRINGS).

COMPLETE REMOVAL

- ◆ Drain the clutch control system, see 7.1.55 (DRAINING THE CLUTCH CONTROL SYSTEM).

⚠ CAUTION

Handle clutch fluid with care; it may chemically alter painted surfaces and the parts in plastic, rubber, etc.

NOTE Do not unscrew the bleeder screw (1), since it remains positioned on the clutch control cylinder screw (2).

Clutch control cylinder screw (2) driving torque: 20 Nm (2.0 Kgm).

- ◆ Unscrew and remove the clutch control cylinder screw (2) [complete with bleeder valve (1)] and take the two sealing washers (3).

⚠ CAUTION

Upon reassembly, replace the two sealing washers with two new washers of the same type.

- ◆ Put a nylon bag on the connection (4) and fix it to the clutch fluid pipe with adhesive tape.
- ◆ Follow the procedure of PARTIAL REMOVAL.

PARTIAL REMOVAL

- ◆ Remove the rubber element (5) from the fairing.
- ◆ Unscrew and remove the three clutch control cylinder screws (6).

Driving torque of the clutch control cylinder screws (6): 12 Nm (1.2 kgm).

- ◆ Take the fairing rubber element spacer (5).
- ◆ Withdraw the clutch control cylinder (8).

Follow ►

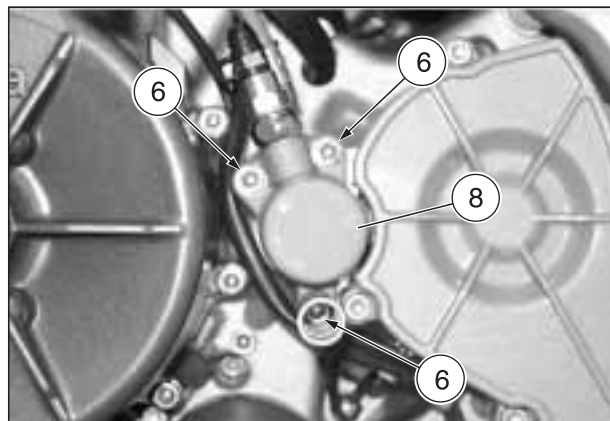
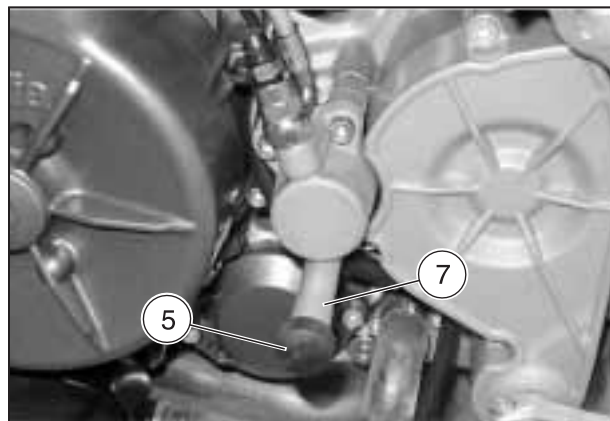
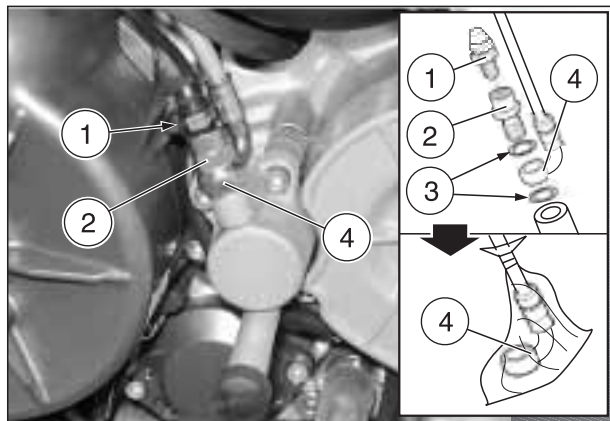

Follow ►

⚠ CAUTION

Proceed with care; the clutch control cylinder (8) remains connected to the clutch control pipe (9).

Once the clutch control cylinder (8) has been removed, do not pull the clutch lever as the piston is liable to come out of its slot, resulting in the spillage of clutch fluid.

For safety reasons, it is advisable to secure the pin by locking it with a plastic clamp (10), (except when it is necessary to bleed the clutch control system).

◆ Where necessary, remove the flange (11).

Upon reassembly:

⚠ CAUTION

Correctly position the flange (11). Do not “overturn” it upon assembly.

NOTE When screwing the clutch control cylinder screws (6), take care to fit the flange (10) and the clutch control cylinder (6) in their seat.

◆ Manually screw the three clutch control cylinder screws (6) thoroughly, then fasten them by applying the prescribed torque.

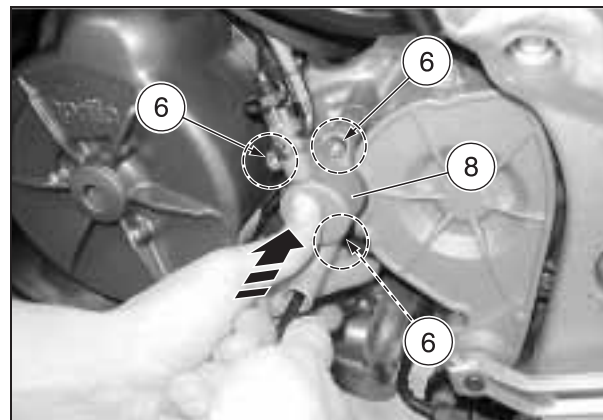
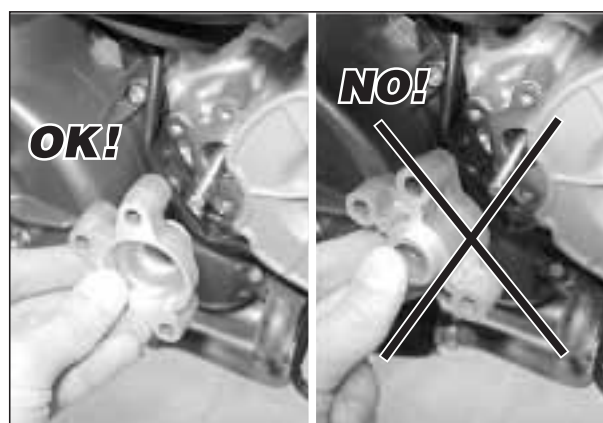
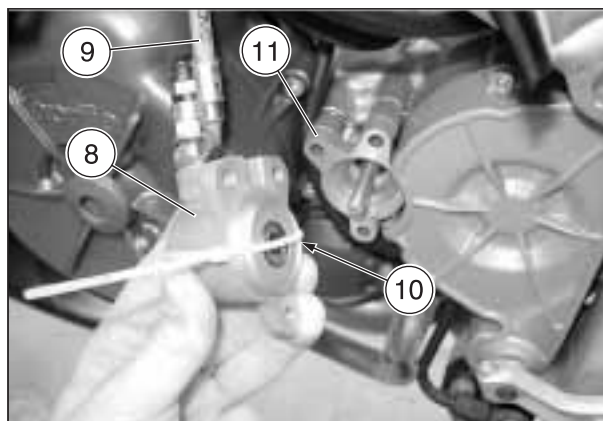

3.3 REMOVING THE WHOLE ENGINE FROM THE FRAME

⚠ CAUTION

The engine must be removed by an authorized centre or by an **aprilia** Official Dealer only.

Carefully read 0.5.1 (PRECAUTIONS AND GENERAL INFORMATIONS).

⚠ CAUTION

The removal of the engine is a particularly complex operation. Therefore, inspect the vehicle carefully before proceeding.

This chapter describes the relevant procedures progressively and in sequential order.

Any reference to operations from other chapters must be interpreted logically in order to avoid components being removed unnecessarily.

Only perform those operations necessary to remove the component in question.

Before going ahead with the following operations, bear in mind that the engine must be removed from the frame from underneath; the equipment for the job must therefore be gathered and set in place beforehand.

Dry weight of the engine ~ 65 kg.

- ◆ Turn the ignition switch to position “”.
- ◆ Position the vehicle on the appropriate rear support stand, see 1.8.2 (POSITIONING THE VEHICLE ON THE REAR SUPPORT STAND).
- ◆ Disconnect the negative cable (-) and positive cable (+) from the battery, in that order.

⚠ CAUTION

When refitting, first connect the positive cable (+) and then the negative one (-).

- ◆ Remove the fuel tank, see 7.1.6 (COMPLETE REMOVAL OF THE FUEL TANK).
- ◆ Remove the two side fairings, see 7.1.28 (REMOVING THE SIDE FAIRINGS).
- ◆ Remove the lower fairing, see 7.1.34 (REMOVING THE LOWER FAIRING).
- ◆ Remove the radiator spoiler, see 7.1.35 (REMOVING THE RADIATOR SPOILER).

⚠ CAUTION

Mark the cables so as to prevent them being mixed up by mistake during refitting.

- ◆ Disconnect the following electric connectors in the order given:
 - generator (1);
 - camshaft position sensor (2);
 - front cylinder coolant thermistor (3);
 - rear cylinder coolant thermistor (4).

⚠ CAUTION

When refitting, make sure the electric connectors are plugged in properly.

Follow ►

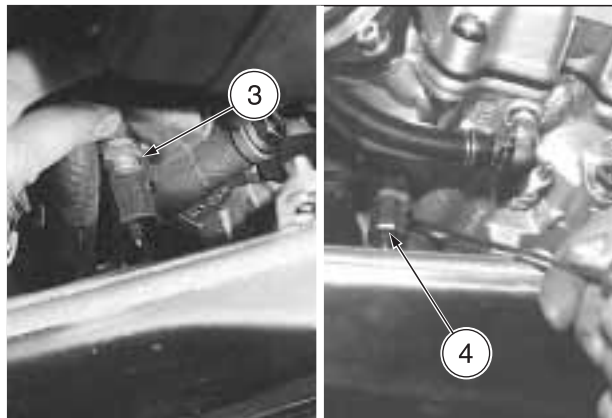
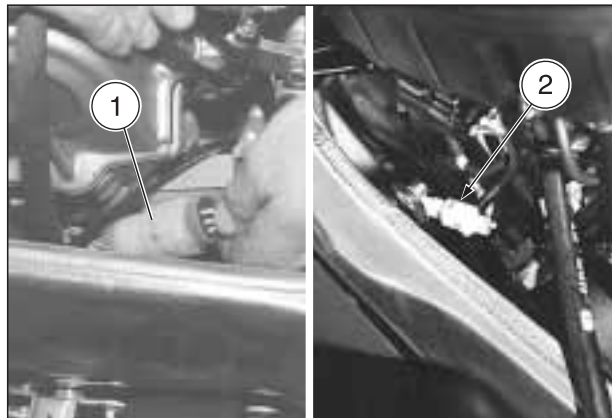
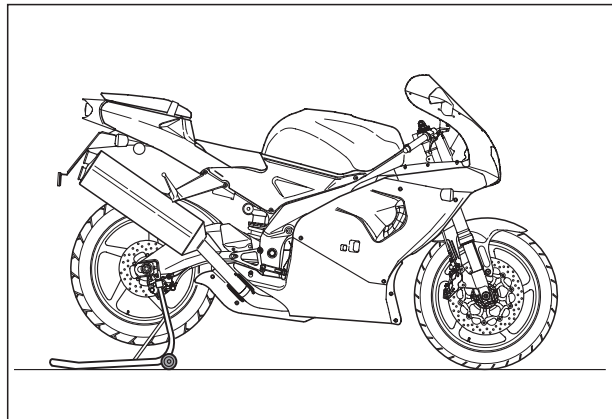
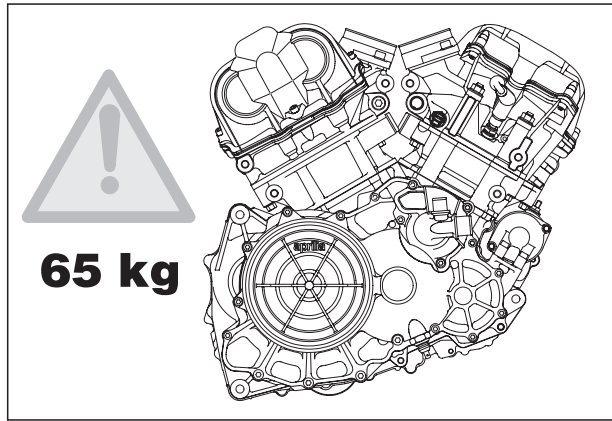

RSV mille

Follow ►

- ◆ Unscrew and remove the screw (5) and disconnect the cable from the “neutral” gear switch (6).
- ◆ Move the protection element (7) aside and disconnect the cable from the engine oil pressure sensor (8).
- ◆ Move the protection element (9) aside, unscrew and remove the nut (10), recover the washer and disconnect the starter motor cable.
- ◆ Remove the rear brake lever and relevant mount (11), see 7.1.48 (REMOVING THE REAR BRAKE LEVER).

▲ CAUTION

Move the mount (11) and secure it in place, taking extreme care as it remains connected to the electric cable by means of the brake light switch (12).

- ◆ Remove the rear brake pump (13), see 7.6.4 (REMOVING THE REAR BRAKE PUMP).

▲ CAUTION

Move the rear brake pump (13) and secure it in place, taking extreme care as it remains connected to the brake fluid pipes.

The brake fluid tank (14) must be held vertically to prevent the fluid spilling out.

- ◆ Remove the clutch control cylinder, see 3.2.3 (REMOVING THE CLUTCH CONTROL CYLINDER).
- ◆ Remove the drive pinion, see 7.1.53 (REMOVING THE DRIVE PINION).
- ◆ Remove the gearshift lever, see 3.2.2 (REMOVING THE GEAR LEVER).
- ◆ Remove the expansion tank, see 5.9 (REMOVING THE EXPANSION TANK).

Follow ►

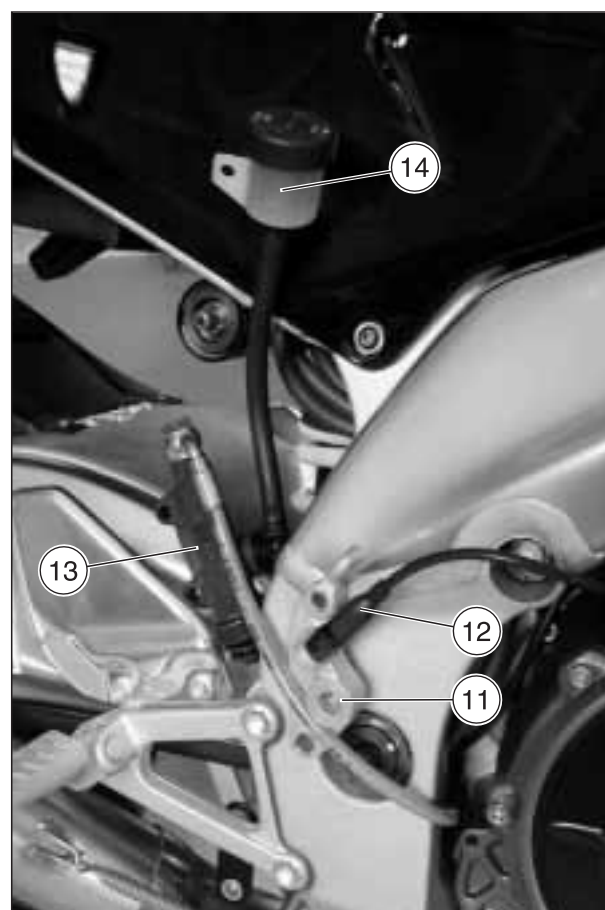
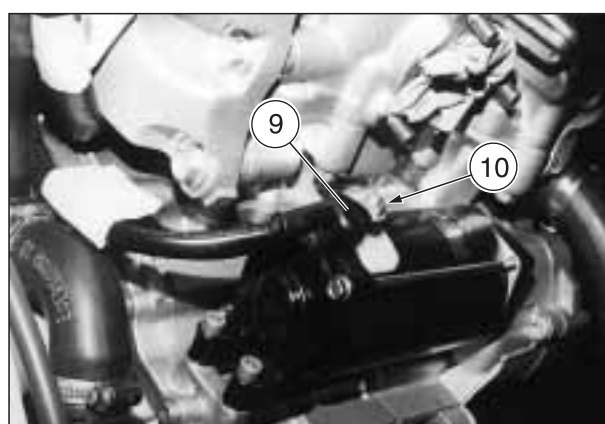
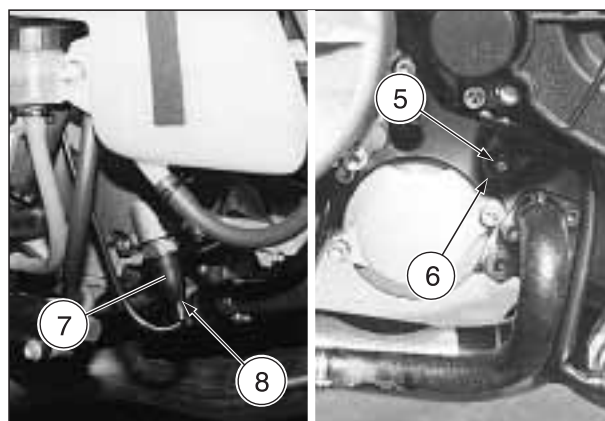

Follow ►

- ◆ ★ Disconnect the spark plug caps (15).

⚠ CAUTION

To clean the outer parts of the engine use a degreaser, brushes and wipers.

Avoid damaging rubber and plastic parts with corrosive or penetrating detergents and solvents.

Should the use of a steam cleaner prove necessary, do not point the high-pressure jets of water, steam or air at the following parts: wheel hubs, controls on the right and left handlebars, brake pumps, instruments and gauges, silencer openings, document compartment, ignition switch/steering lock, electrical components.

- ◆ Clean the outside of the engine thoroughly.
- ◆ Remove the exhaust pipes, see 3.2.1 (REMOVING THE EXHAUST PIPES).
- ◆ ★ Disconnect the electric connector (20) from the electrofan.
- ◆ Disconnect the electric cables from the horn.

⚠ CAUTION

When refitting, make sure the electric connectors are plugged in properly.

⚠ CAUTION

Mark the coupling and pipes so as to prevent them being swapped over by mistake during refitting.

- ◆ Remove the engine oil tank (16), see 7.1.51 (REMOVING THE ENGINE OIL TANK) together with the engine oil radiator (17), see 7.1.52 (REMOVING THE ENGINE OIL RADIATOR), disconnecting the pipes connecting them to the engine (18) (19).
- ◆ Remove the radiators (21) (22) joined together, see 5.2 (REMOVING THE RADIATORS), complete with electrofans, horn and mounts.

Follow ►

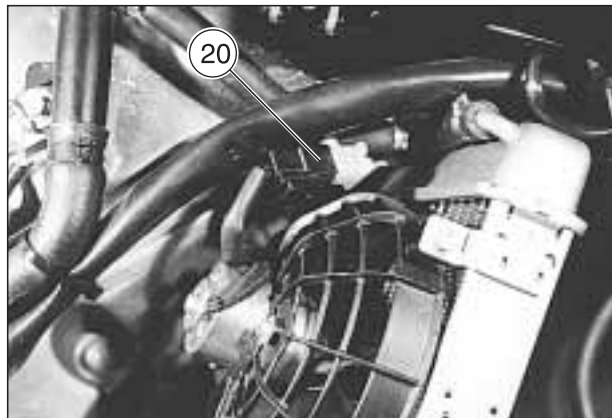
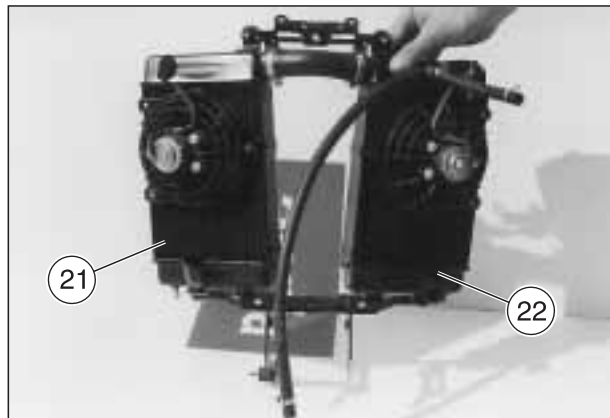
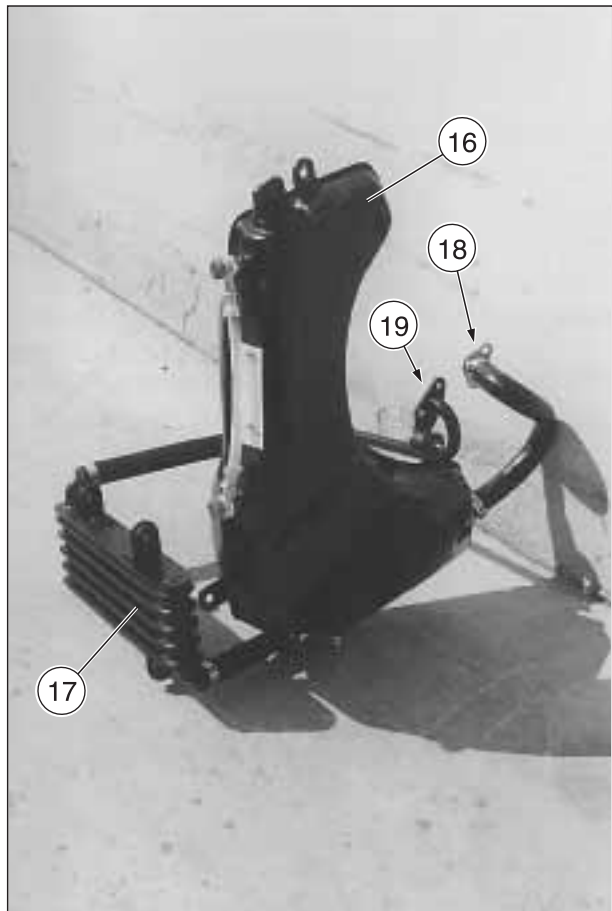

Follow ►

NOTE The pipe (A), the three-way manifold (23), the breather pipe (B) and the two couplings (C) (D) can remain installed on the engine (connected to the cylinders).

- ◆ Remove the complete throttle body (24), see 4.8.2 (REMOVING THE THROTTLE BODY).
- ◆ Loosen and move the clamp (25).

NOTE Have the appropriate special tool **OPT** to hand:
– aprilia part# 0277295 (hose clamp installation pliers).

⚠ CAUTION

Upon installation, replace the hose clamp that has been removed with a new one having the same dimensions, see 0.4.2 (SPARE PARTS CATALOGUES).

Do not attempt to reinstall the removed hose clamp, since it is unusable.

Do not replace the removed hose clamp with a screw clamp or with other types of clamp.

- ◆ Release the hose clamp (26).
- ◆ Remove the complete thermal expansion valve (28), see 5.6 (REMOVING THE THERMAL EXPANSION VALVE) together with the three couplings.
- ◆ Release the hose clamp (27).
- ◆ Slip the coupling (29) off the coolant pump.

Follow ►

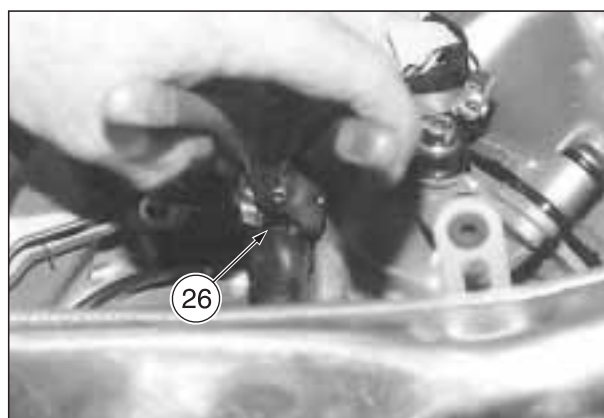
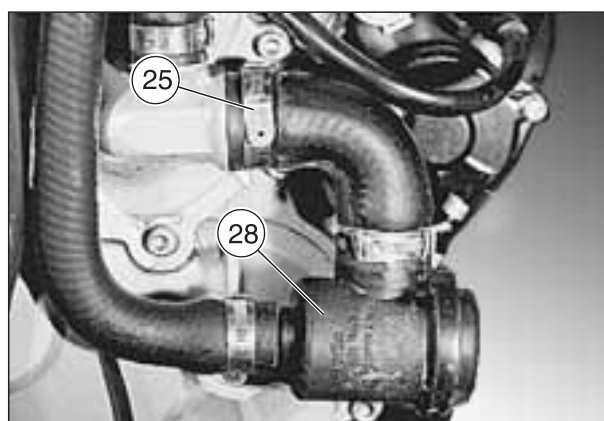
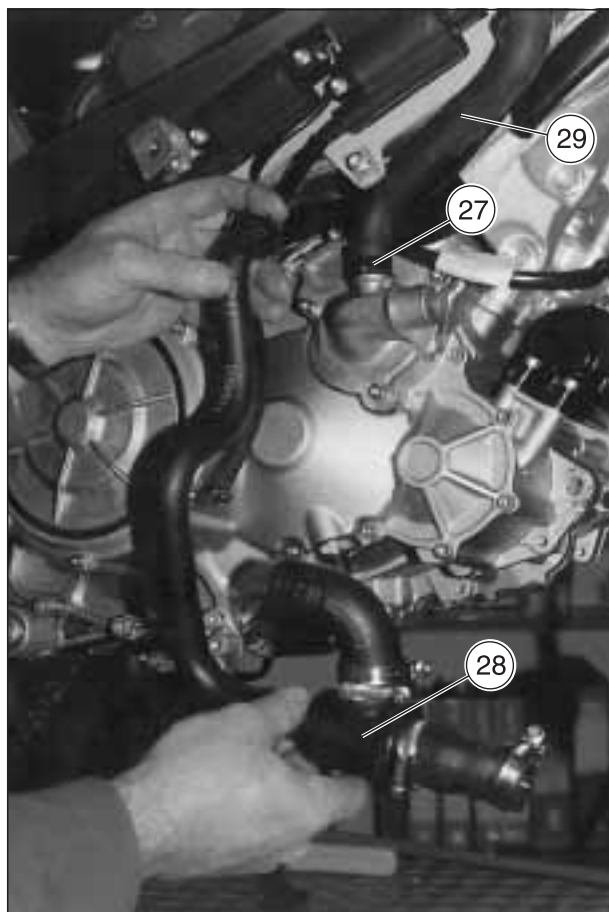
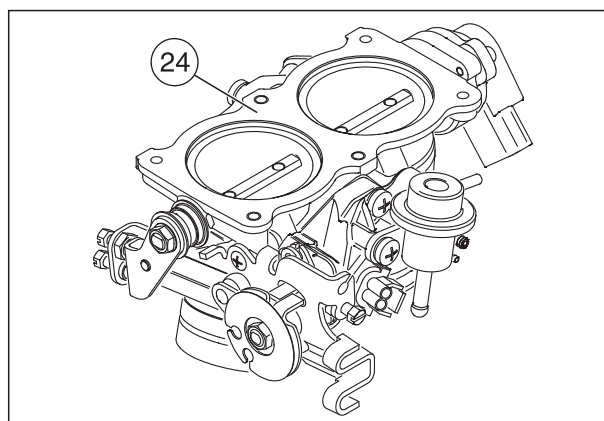
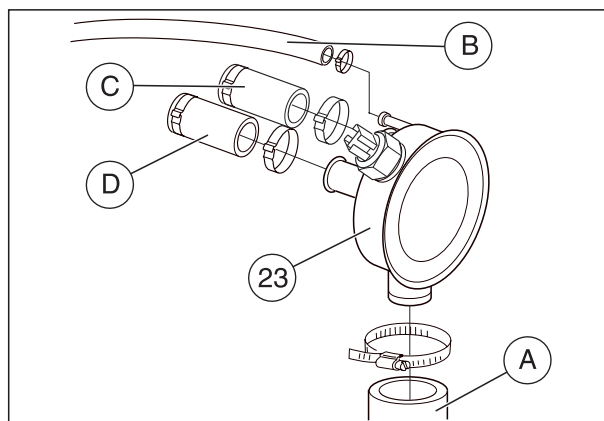

Follow ►

⚠ CAUTION

Free all the cables and pipes from the respective clamps located at intervals along their routes.

Procure an equal number of clamps to be used for re-fitting.

Plug all openings on the engine, pipes and couplings to prevent foreign bodies getting in.

- ◆ Gather the electric cables together and secure them in place with adhesive tape so that they do not get in the way of the engine being lifted out from underneath.
- ◆ Unscrew and remove the screws (30) and recover the plate (31).

Screws (30) driving torque: 40 Nm (4.0 kgm).

NOTE Have the appropriate special tool **OPT** to hand:
 – aprilia part# 8140183 (engine lifting eye hook) (32), a hoist (33) and lifting straps (34).

- ◆ Fasten the special engine lifting hook (32) on and secure it in place with the screws (30).

⚠ WARNING

The hoist (33) and the bands (34) for the lifting operation must be suitable for safely bearing the weight of the engine. The engine weight approx. 65 kg.

- ◆ Hook the bands (34) onto the hoist (33) and the hook (32) as illustrated.

⚠ WARNING

The entire engine and hoist setup must be stable, ensuring that the subsequent operations can be performed safely.

- ◆ Lift the hoist arm (33) until the bands (34) are taught.

⚠ CAUTION

The hoist arm (33) must be lifted just enough for the engine to be held in place during the removal of the elements fastening it to the frame.

Follow ►

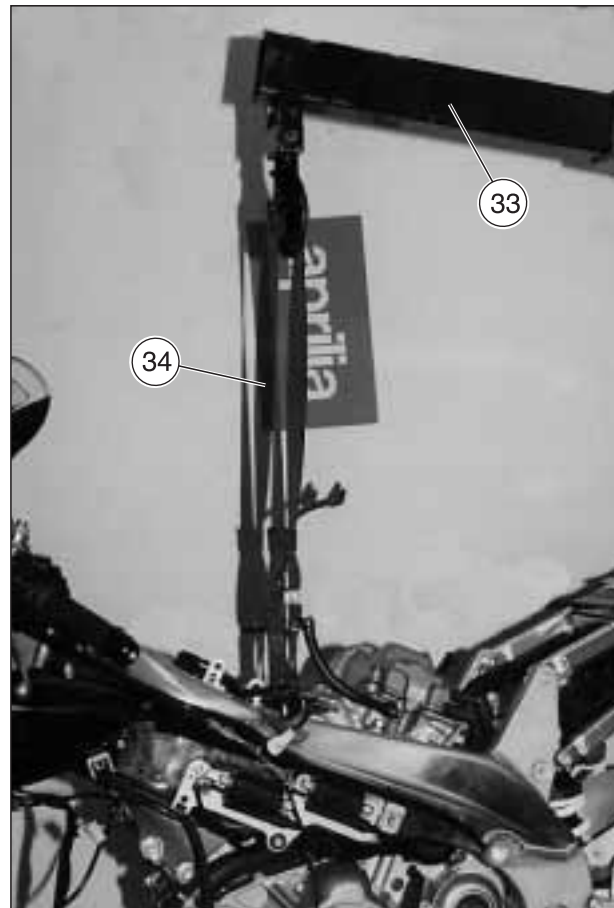
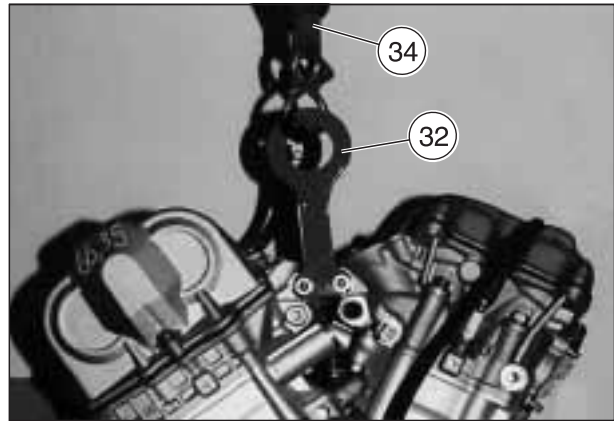
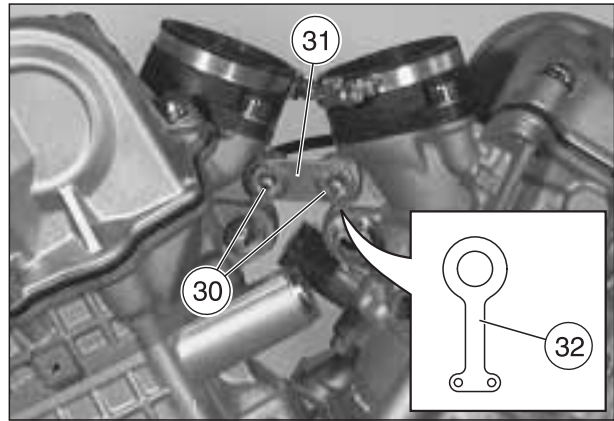

RSV mille

Follow ►

NOTE The elements fastening the engine to the frame must be removed in the order given:

RIGHT SIDE → A → B → C → D.

LEFT SIDE → E → F → G → H.

Follow ►

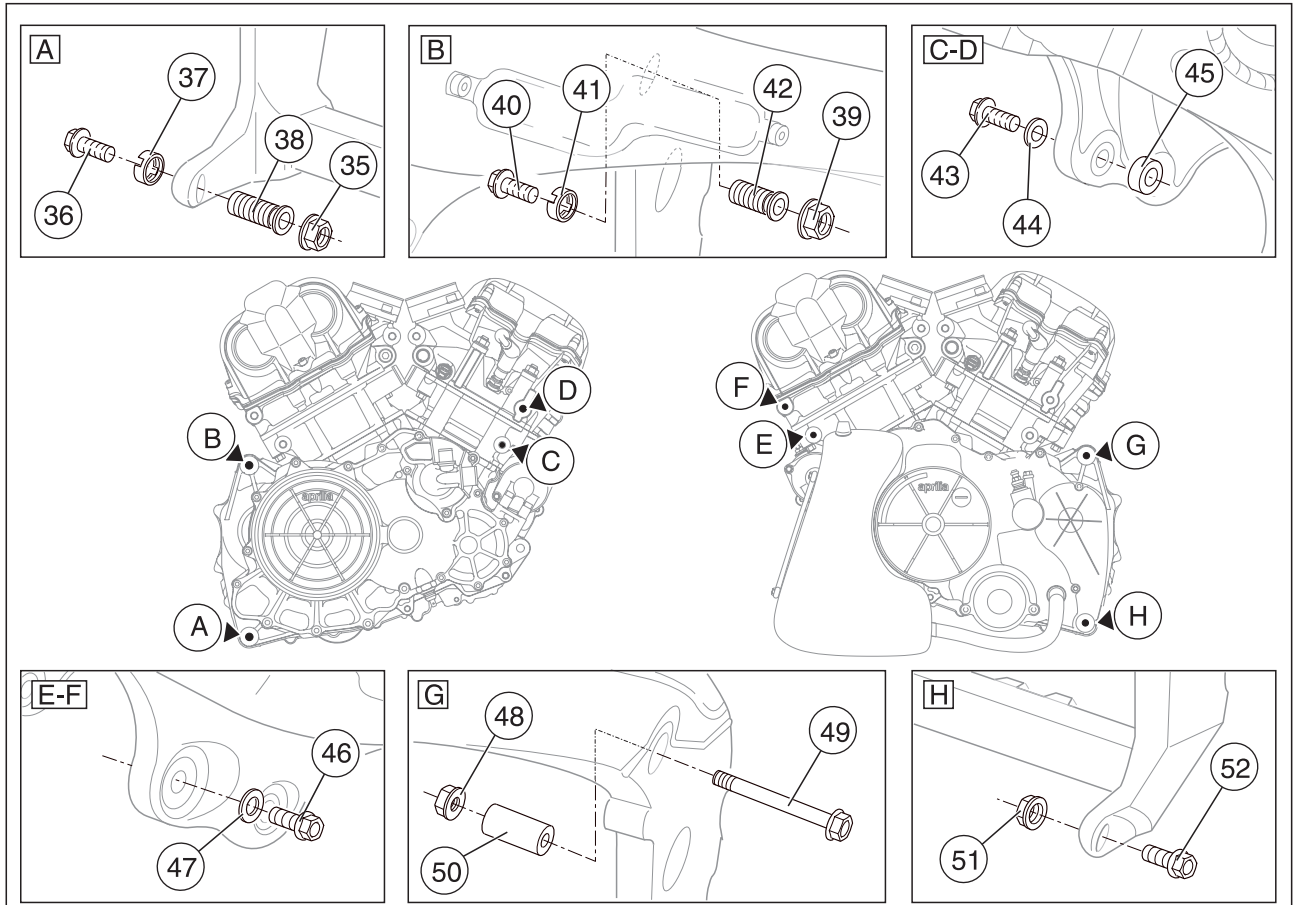

Follow ►

- ◆ Holding the inside nut (35) still, loosen the screw (36).
Nut (35) and screw (36) driving torque: 50 Nm (5.0 kgm).
- ◆ Holding the inside nut (39) still, loosen the screw (40).
Nut (39) and screw (40) driving torque: 50 Nm (5.0 kgm).
- ◆ Unscrew and remove the two screws (43) and recover the relevant washers (44).
Screws (43) driving torque: 50 Nm (5.0 kgm).
- ◆ Recover the two spacers (45).
- ◆ Unscrew and remove the two screws (46) and recover the washers (47).
Screws (46) driving torque: 50 Nm (5.0 kgm).

Follow ►

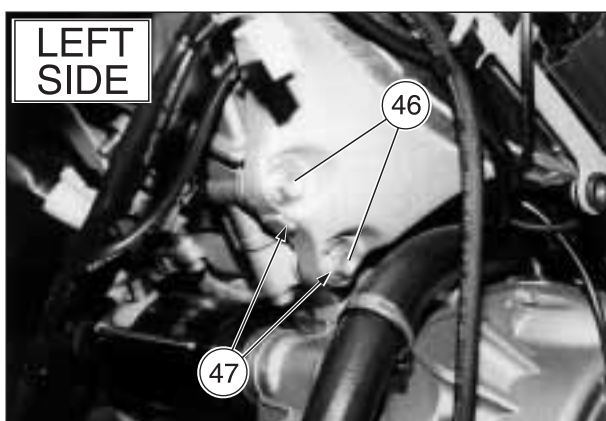
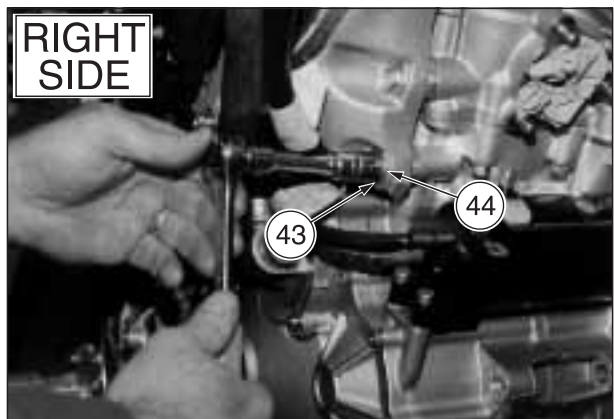
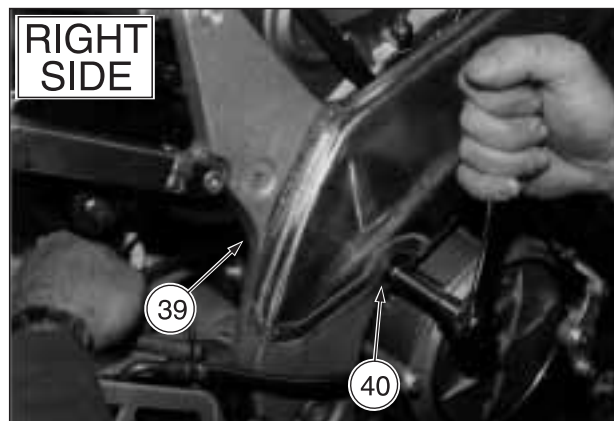
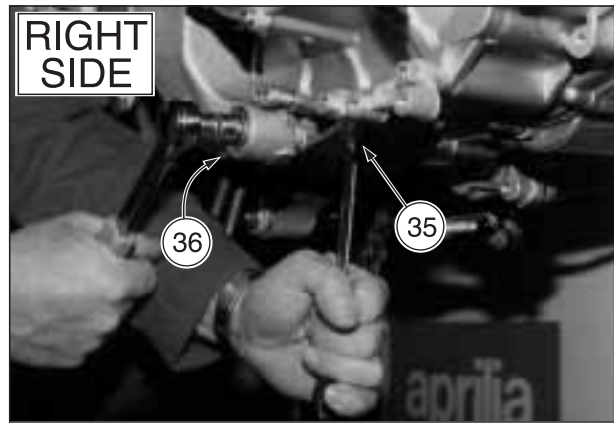

RSV mille

Follow ►

- ◆ Use the special setscrew spanner **OPT** (53) (cod. 8140203) to loosen and remove the lock rings (41) (37).

Lock rings (41) (37) driving torque: 50 Nm (5.0 kgm).

- ◆ Unscrew the adjusting bushes (38 - 42) all the way until they touch the frame.

Adjusting bushes (38) (42) driving torque: 10 Nm (1.0 kgm).

⚠ CAUTION

When reassembling, screw the adjusting bushes (38) (42) on by hand all the way until they touch the engine before torquing them to specification.

- ◆ Holding the inside nut (35) still, loosen and remove the screw (36).
- ◆ Holding the inside nut (39) still, loosen and remove the screw (40).
- ◆ Holding the inside nut (51) still, loosen and remove the screw (52).

Nut (51) and screw (52) driving torque: 50 Nm (5.0 kgm).

- ◆ Holding the inside nut (48) still, loosen and remove the screw (49).

Nut (48) and screw (49) driving torque: 50 Nm (5.0 kgm).

- ◆ Take the spacer (50).

Follow ►

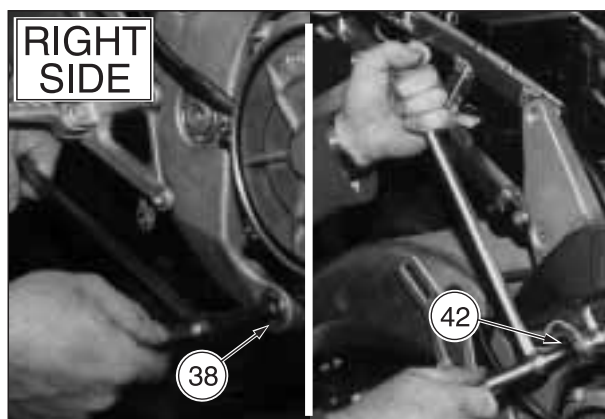
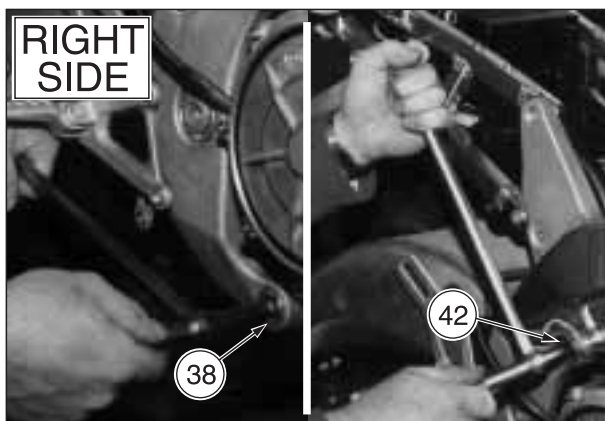
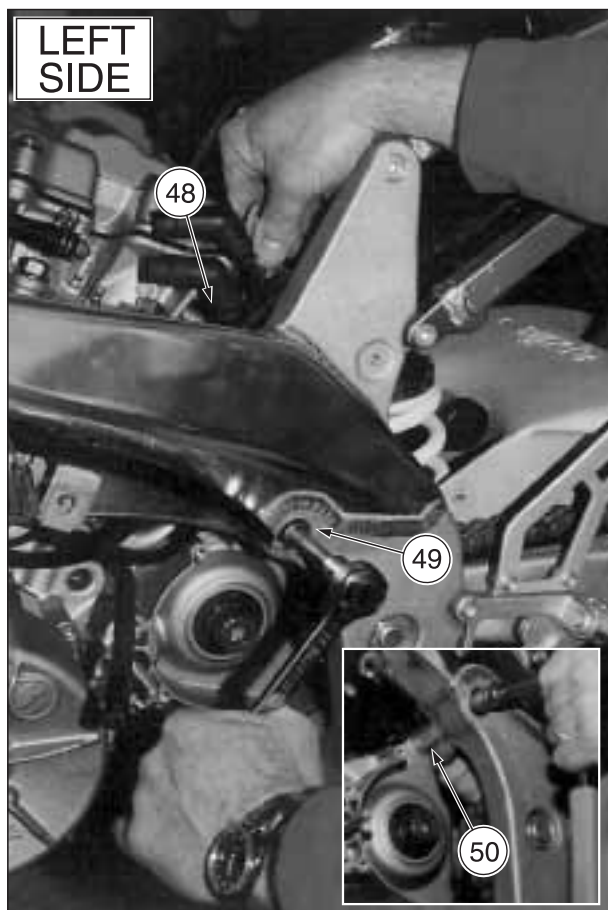
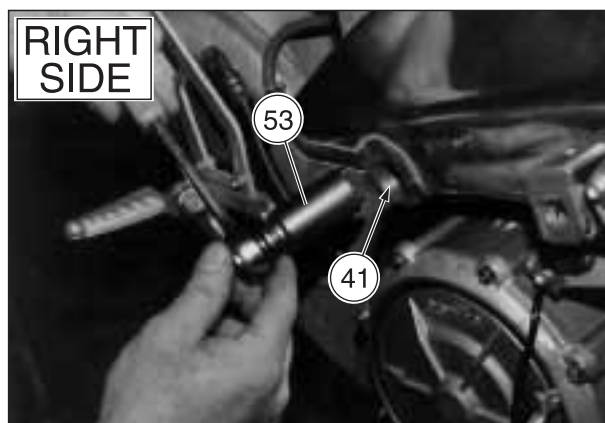

Follow ►

⚠ WARNING

The engine is now freed and has nothing fastening it.

Handle with care: watch your fingers and limbs.

Clear the floor, on which the engine is to be set down, of any tools and clean thoroughly.

- ◆ Lift the hoist arm by a few millimeters in order to “release” the engine from the frame.
- ◆ Lower the hoist arm until the engine is gently set down on the floor.
- ◆ Secure the engine so that it does not fall over if poorly balanced.
- ◆ Unhook the bands (34) from the hoist.
- ◆ Slide the bands (34) out from the frame.
- ◆ Move the engine from under the frame.
- ◆ Hook the bands (34) back up to the engine.

NOTE If the engine is to be worked on, set it on the relevant stand (54), see 3.3.1 (POSITIONING THE ENGINE ON THE ENGINE SUPPORT STAND).

⚠ CAUTION

If no work is to be performed on the engine, leave it rested on the floor and attached to the bands (34) and hoist for extra safety.

- ◆ Complete the cleaning of the engine outside with the utmost care.

⚠ CAUTION

Use a detergent, brushes and rags to clean the engines outer surfaces.

Avoid damaging rubber and plastic parts with corrosive or penetrating detergents and solvents.



3.3.1 POSITIONING THE ENGINE ON THE ENGINE SUPPORT STAND

Carefully read 0.5.1 (PRECAUTIONS AND GENERAL INFORMATIONS).

NOTE Have the appropriate special tools **OPT** to hand:

- **aprilia** part# 8140188 (engine support) (1);
- **aprilia** part# 8140187 (engine support stand) (2).
- ◆ Remove the entire engine from the frame, see 3.3 (REMOVING THE WHOLE ENGINE FROM THE FRAME).

⚠ WARNING

The entire engine and hoist setup must be stable, ensuring that the subsequent operations can be performed safely.

- ◆ Raise the hoist arm, lifting the engine at approximately 1 meter from the ground.
- ◆ Install the engine support (1) on the engine.

⚠ WARNING

Tighten the screws (3) thoroughly, since the incomplete tightening of the screws (3) may cause the engine to fall down, with consequent damage to persons, property and the engine itself.

- ◆ Screw and tighten the three screws (3).
- ◆ Assemble the engine support stand (2) with the engine support (1) and insert the safety pin (4) in the appropriate seat.
- ◆ Clear and clean the area on which the stand-engine assembly will be positioned.
- ◆ Using the hoist, move the stand-engine assembly to the desired area.
- ◆ Lower the hoist arm and rest the stand-engine assembly on the area prepared for this purpose.

⚠ WARNING

Before releasing the hoist straps, make sure that the stand-engine assembly is stable. The overturning of the assembly may damage persons, property and the assembly itself (engine included).

- ◆ Release the stand-engine assembly from the coupling of the hoist (5).

3.4 DISASSEMBLING THE ENGINE

For the disassembly of the engine, refer to the service and repair manual, see 0.4.1 (ENGINE SERVICE AND REPAIR MANUALS).

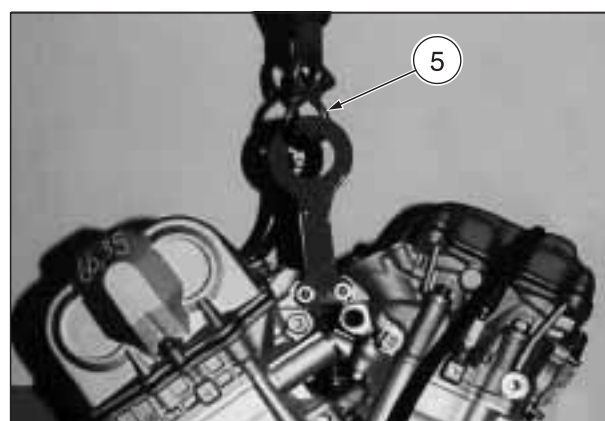
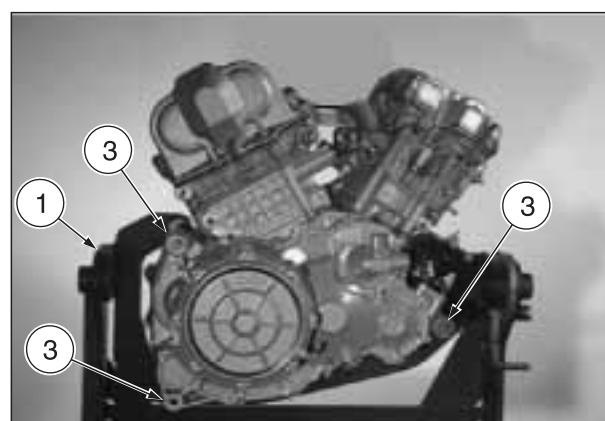
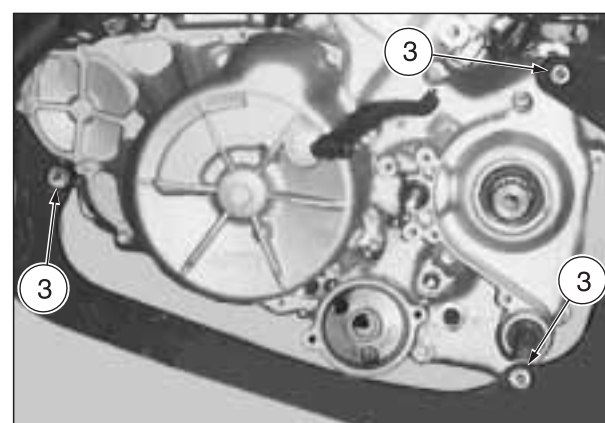
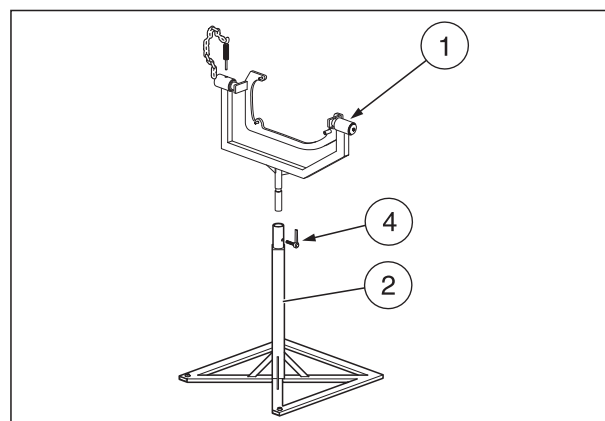

3.5 REFITTING THE WHOLE ENGINE ON THE FRAME

Carefully read 0.5.1 (PRECAUTIONS AND GENERAL INFORMATIONS).

NOTE In order to refit the whole engine on the frame, the same procedure used for its removal must be followed in the reverse order, see 3.3 (REMOVING THE WHOLE ENGINE FROM THE FRAME).

Nonetheless, before commencing, the operations indicated below must be performed.

⚠ WARNING

Handle with care.

Watch your fingers and limbs.

- ◆ Make sure the adjusting bushes (38 - 42) are unscrewed all the way so that they touch the frame.
- ◆ Nudge the engine along gradually until the engine/frame fastening holes (A) (B) (C) (D) are perfectly aligned.

Once the engine refitting procedure is complete, perform the operations indicated below.

- ◆ Make sure all the nuts/screws securing the engine are properly torqued.
- ◆ Top up the coolant, see 2.15 (CHECKING AND TOPPING UP COOLANT).
- ◆ Top up the motor oil, see 2.13 (CHECKING THE ENGINE OIL LEVEL AND TOPPING UP).
- ◆ If the engine has been overhauled, bleed the engine oil circuit, see 3.6.1 (BLEEDING THE ENGINE OIL CIRCUIT) and check the engine oil pressure, 3.6.2 (CHECKING THE ENGINE OIL PRESSURE).
- ◆ Check the driving chain is taught and, where necessary, adjust, see 2.36.1 (CHECKING THE DRIVE CHAIN SLACK) and 2.36.3 (ADJUSTING THE DRIVING CHAIN)

⚠ CAUTION

Perform a general check of all the components affected by the procedure, in particular make sure:

- the electric cables are fastened with relevant clamps;

⚠ CAUTION

None of the cables must be twisted and/or squashed.

- the electric connectors are plugged in properly;
- the pipes and couplings are connected properly and secured with relevant clamps;
- the throttle cable and cold-start cable slide freely and are not pulled too tight when the handlebar is turned;
- the gearshift lever is positioned correctly;
- the rear brake lever is positioned correctly.

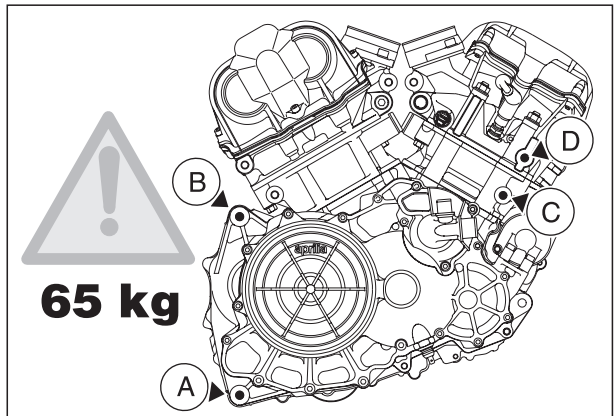
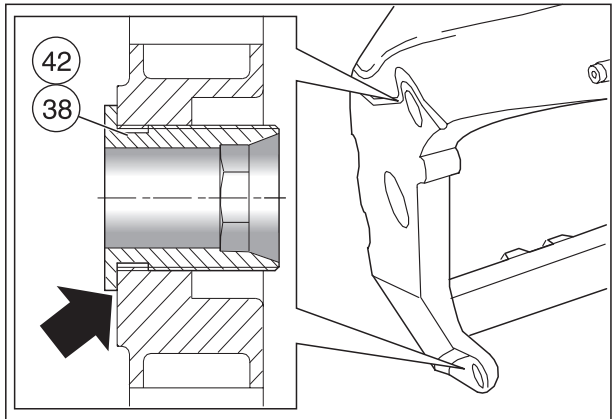
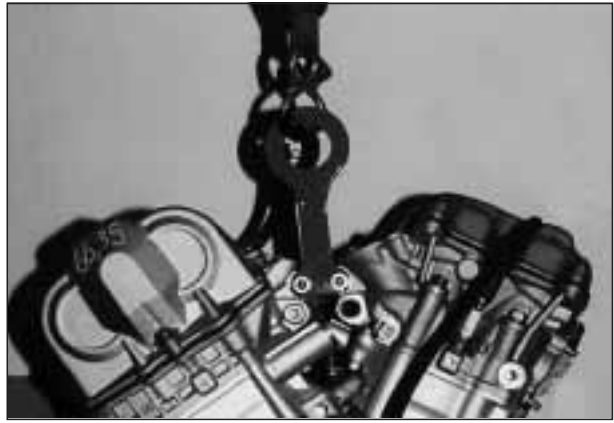

3.6 ENGINE CHECKS SUBSEQUENT TO REASSEMBLY

Carefully read 0.5.1 (PRECAUTIONS AND GENERAL INFORMATIONS).

3.6.1 BLEEDING THE ENGINE OIL CIRCUIT

- ◆ Refill the engine with motor oil, see 2.14 (CHANGING THE ENGINE OIL AND THE OIL FILTER).
- ◆ Slip the two electric connectors off the two injectors (1) (2).
- ◆ Press the start push button and let the engine run until the engine oil pressure warning light LED goes out.
- ◆ Insert the two electric connectors on the two injectors (1) (2).
- ◆ Top up with motor oil until the tank level reaches the prescribed limit, see 2.13 (CHECKING THE ENGINE OIL LEVEL AND TOPPING UP).
- ◆ Start the engine and let it idle for approx. 10 minutes.
- ◆ Check the oil level again and, where necessary, top up.

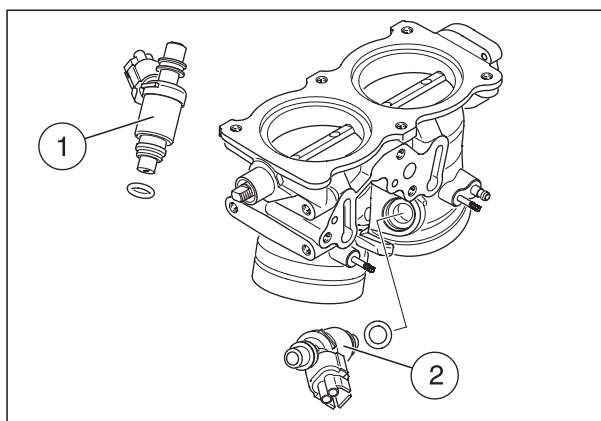

3.6.2 CHECKING THE ENGINE OIL PRESSURE

NOTE Have the appropriate special tool **OPT** to hand:

- **aprilia** part# 8140181 (fuel-oil pressure gauge-compression) (4).

- ◆ Connect the oil pressure gauge (4) in place of the engine oil pressure sensor (3).

Engine oil pressure: min. 50 kPa (0.5 bar).

NOTE Check the oil pressure at a temperature of 80 °C (176 °F) and at a speed of at least 1200 rpm.



CAUTION

If the oil pressure is below the minimum limit, check the oil pump and relevant drive assembly.

- ◆ During reassembly, coat the thread of the engine oil pressure sensor (3) with **LOCTITE® 243**.

Engine oil pressure sensor driving torque: 15 Nm (1.5 kgm).

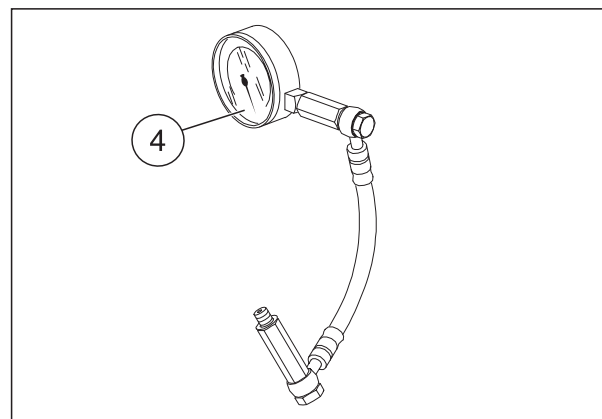

3.6.3 CYLINDER SYNCHRONIZATION

See 4.8.10 (CYLINDER SYNCHRONIZATION).

FUEL SUPPLY SYSTEM

4

FUEL SUPPLY SYSTEM

TABLE OF CONTENTS

4.1 FUEL TANK	4-3-00
4.1.1 MAINTENANCE	4-4-00
4.1.2 CHECKING THE FUEL SUPPLY	4-4-00
4.2 DRAINING THE FUEL TANK	4-4-00
4.3 REMOVING THE WHOLE FUEL SUPPLY PUMP UNIT	4-5-00
4.4 REMOVING THE FUEL LEVEL SENSOR	4-6-00
4.5 REMOVING THE DELIVERY FILTER ..	4-6-00
4.6 REMOVING THE FUEL SUPPLY PUMP	4-7-00
4.7 ENGINE MANAGEMENT	4-8-00
4.7.1 FOREWORD	4-8-00
4.7.2 SENSORS	4-9-00
4.7.3 INJECTION SYSTEM DIAGRAM	4-11-00
4.7.4 ENGINE CONTROL UNIT CONNECTORS	4-12-00
4.7.5 AUTOMATIC TESTING	4-13-00
4.7.6 ELIMINATING ELECTRONIC SYSTEM FAULTS ACCORDING TO THE INFORMATION SENT UP ON THE DISPLAY	4-13-00
4.7.7 CAMSHAFT POSITION SENSOR	4-13-00
4.7.8 DRIVING SHAFT POSITION SENSOR	4-13-00
4.7.9 INTAKE PRESSURE SENSOR	4-13-00
4.7.10 INTAKE PRESSURE SENSOR	4-13-00
4.7.11 THROTTLE VALVE POTENTIOMETER	4-13-00
4.7.12 COOLANT THERMISTORS	4-13-00
4.7.13 AIR THERMISTOR	4-13-00
4.7.14 IGNITION COILS	4-13-00
4.8 THROTTLE BODY	4-14-00
4.8.1 REMOVING THE INJECTORS	4-14-00
4.8.2 REMOVING THE THROTTLE BODY	4-14-00
4.8.3 DISASSEMBLING THE THROTTLE BODY	4-16-00
4.8.4 INSPECTING THE THROTTLE BODY	4-18-00
4.8.5 REFITTING THE THROTTLE BODY	4-19-00
4.8.6 REPLACING THE THROTTLE VALVE CONTROL LEVER	4-21-00
4.8.7 CHECKING THROTTLE VALVE CONTROL SHAFT END PLAY	4-23-00
4.8.8 ADJUSTING THE THROTTLE BODY	4-24-00
4.8.9 CHANGING AND ADJUSTING THE THROTTLE VALVE POTENTIOMETER ..	4-25-00
4.8.10 CYLINDER SYNCHRONIZATION	4-26-00

4.1 FUEL TANK

The filler cap is to be found on the top of the tank, whilst the bottom part houses:

- the fuel supply pump unit;
- a breather pipe for the outlet of the fuel vapours generated due to excessive pressure inside the tank;
- a pipe for draining off petrol in the event the tank is overfilled.

Carefully read 0.5.1 (PRECAUTIONS AND GENERAL INFORMATIONS) and 1.2.1 (FUEL).

⚠ WARNING

Fuel vapours are noxious for your health. Before proceeding, make sure that the room in which you are working is properly ventilated. Do not inhale fuel vapours.

Avoid any contact of the fuel with the skin. Do not smoke and do not use naked flames. Do not dispose of fuel in the environment.

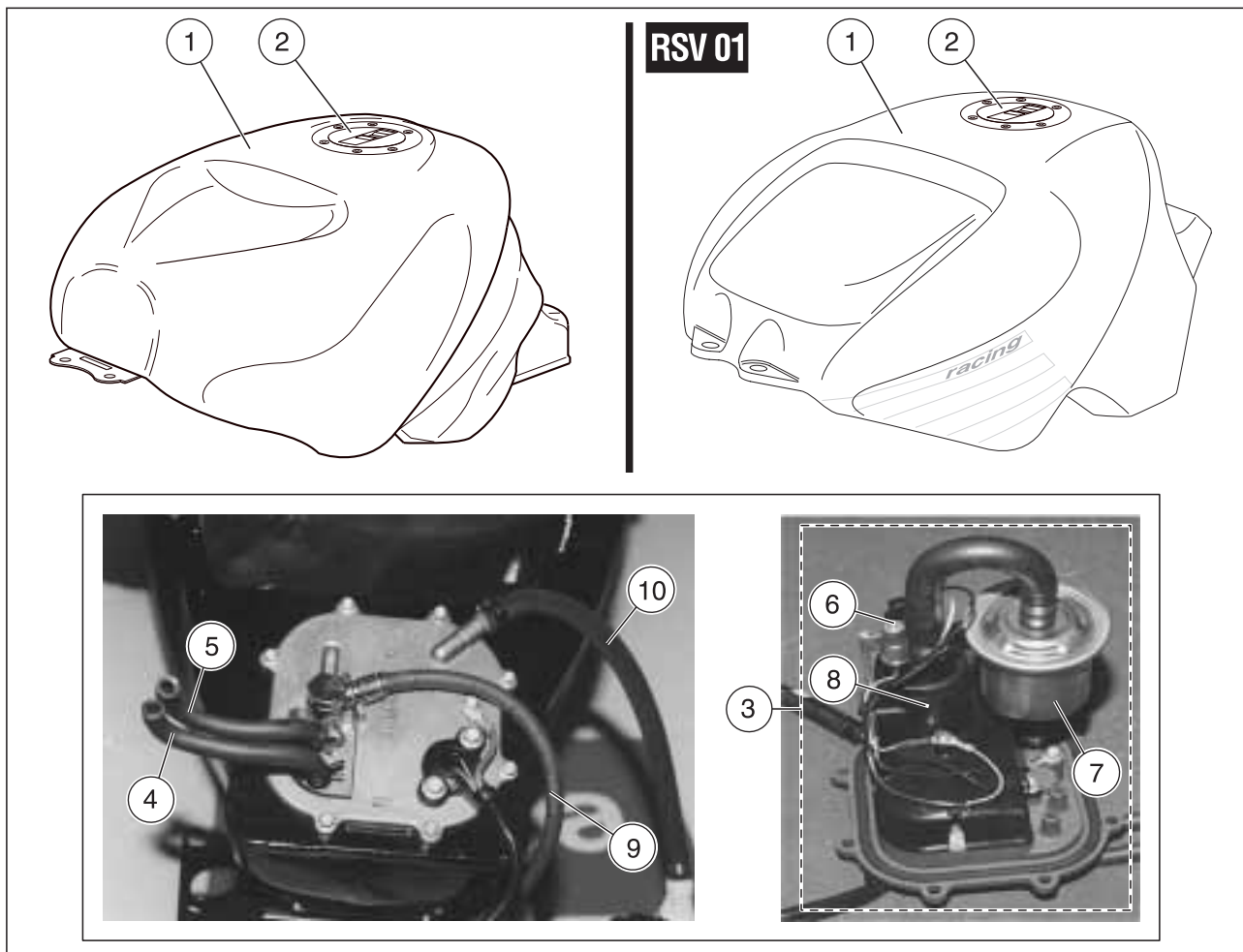

Key

NOTE RSV 01

The pipes (4) and (5) are not connected to the flange, but directly to the fuel tank, while the two couplings on the flange are plugged.

- 1) Fuel tank
- 2) Filler cap
- 3) Fuel supply pump unit
- 4) Fuel vapour breather pipe (for the vapours produced by excessive pressure inside the tank)
- 5) Fuel "overflow" drainage pipe

- 6) Fuel level sensor
- 7) Fuel delivery filter
- 8) Fuel supply pump
- 9) Fuel delivery pipe
- 10) Fuel return pipe

4.1.1 MAINTENANCE

NOTE RSV 01 The pipes (1) and (2) are not provided and the two couplings on the flange are plugged.

- ◆ When the fuel supply pump is to be removed, see 4.3 (REMOVING THE WHOLE FUEL SUPPLY PUMP UNIT), it is advisable to make sure the pipes (1) (2) (3) (4) are intact and that the following are working properly:
 - fuel level sensor (5), see 6.10.2 (LOW FUEL WARNING LIGHT);
 - fuel supply pump (6), see 6.5.2 (CHECKING THE FUEL PUMP).
- ◆ Change the delivery filter (7).

NOTE During this procedure, it is also advisable to wash the tank completely.

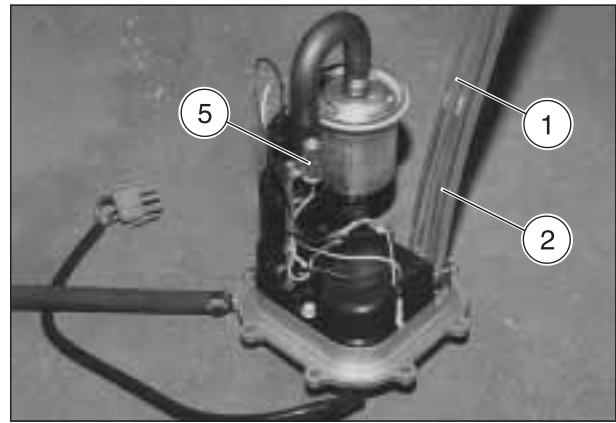

4.1.2 CHECKING THE FUEL SUPPLY

Check the fuel pipes every 7500 km (4687 mi) or 8 months; replace every 4 years.

⚠ WARNING

Check the delivery pipe (8), return pipe (9) and relevant connections extremely carefully; the operating pressure of the delivery pipe (8) is approx. 450 kPa (4.5 bar).

Any fuel pipes featuring cracks or cuts must be replaced, without exception.

Fuel leaking from the flange (10) might be due to a damaged O-ring (11), consequently:

- ◆ Remove the whole fuel supply pump unit, see 4.3 (REMOVING THE WHOLE FUEL SUPPLY PUMP UNIT), check its state of repair and, where necessary, replace it.
- ◆ Open the filler cap and make sure the vent on the tank is not clogged. Where necessary, unclog it using a compressed air jet.

NOTE For further details see 6.5.2 (CHECKING THE FUEL PUMP).

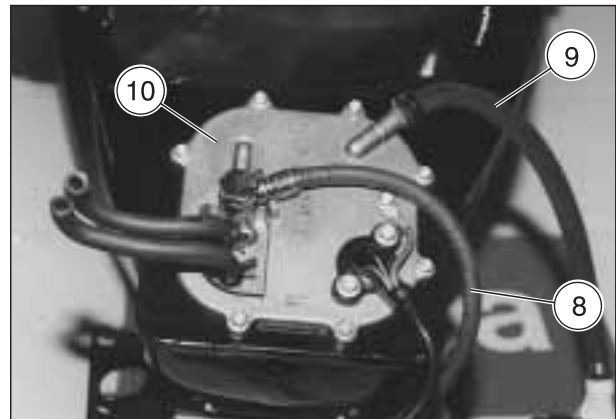
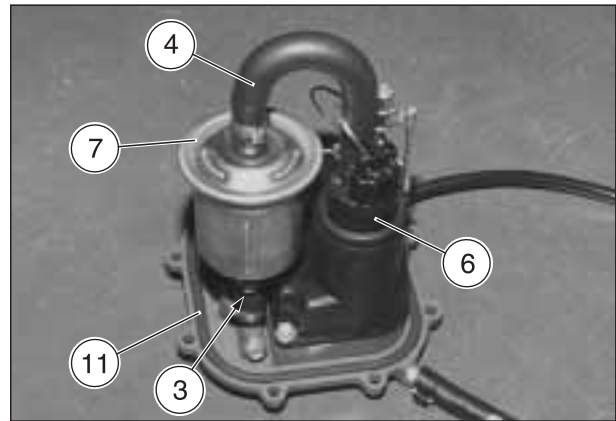

4.2 DRAINING THE FUEL TANK

See 2.9 (DRAINING THE FUEL TANK) for the fuel tank draining procedure.

4.3 REMOVING THE WHOLE FUEL SUPPLY PUMP UNIT

Carefully read 0.5.1 (PRECAUTIONS AND GENERAL INFORMATIONS), 1.2.1 (FUEL) and 4.1.1 (MAINTENANCE).

- ◆ Remove the fuel tank completely, see 7.1.6 (COMPLETE REMOVAL OF THE FUEL TANK).

⚠ CAUTION

Handle the fuel tank with care and avoid scraping or damaging them.

NOTE Set the tank on a clean surface with the pump unit facing up.

- ◆ Unscrew and remove the screws (1).

NOTE For model **RSV01**, DO NOT carry out the operations marked with the symbol “*”.

NOTE When reassembling Screw all the screws on manually and tighten them in a crisscross pattern in the following order: A → B → C → D → E → F → G → H.

Screws (1) driving torque: 7 Nm (0.7 kgm).

- * **NOTE** Have the special tool **OPT** to hand:
 - aprilia part# 0277295 (hose clamp installation pliers).

⚠ CAUTION

Upon installation, replace the hose clamp that has been removed with a new one having the same dimensions, see 0.4.2 (SPARE PARTS CATALOGUES).

Do not attempt to reinstall the removed hose clamp, since it is unusable.

Do not replace the removed hose clamp with a screw clamp or with other types of clamp.

- ◆ * Lift the pump unit (2) just enough to be able to get at the hose clamps (3) (4).
- ◆ * Release the hose clamp (3).
- ◆ * Release the hose clamp (4).

⚠ CAUTION

When removing the pump unit (2), take care not to damage the pipes and the fuel level sensor (5).

- ◆ Remove the whole pump unit (2).

NOTE The fuel pipe (6) can remain installed on the fuel pump flange (7).

Only if it is necessary to change the fuel pump flange (7), or the entire fuel pump assembly (2), or the fuel pipe (6):

- ◆ Release the hose clamp (8).
- ◆ Withdraw the fuel pipe (6).

NOTE Upon reassembly. Apply LOCTITE® 518 to the O-ring of the fuel pump flange.

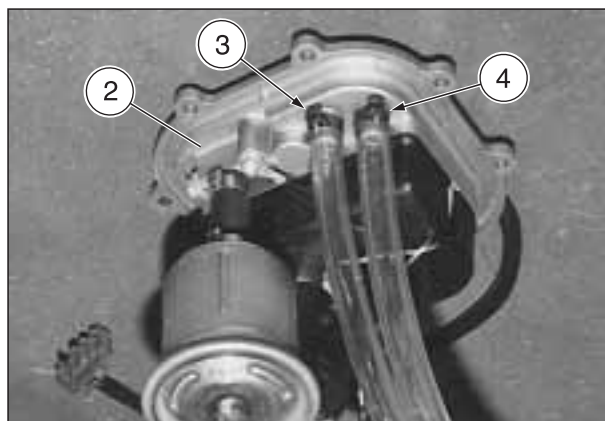
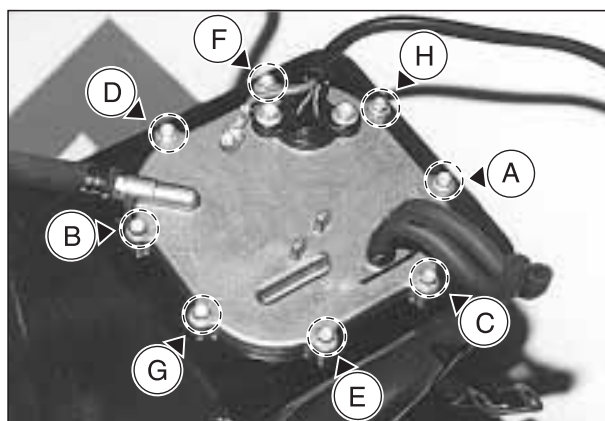
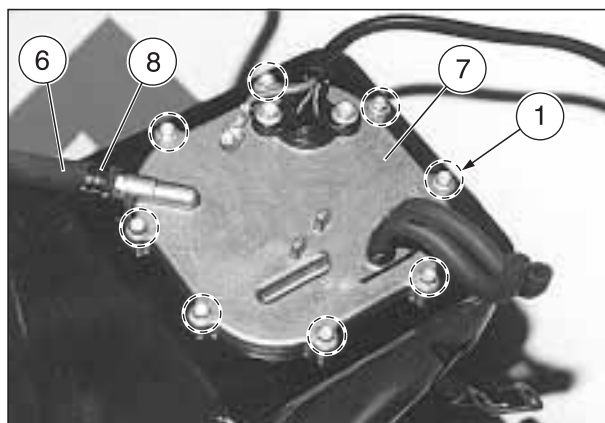

4.4 REMOVING THE FUEL LEVEL SENSOR

- ◆ Remove the whole fuel supply pump unit, see 4.3 (REMOVING THE WHOLE FUEL SUPPLY PUMP UNIT).
- ◆ Release and remove the clamp (1).

Before removing the screws (2) (3), make sure the relevant electric terminals fastened on them are positioned correctly.

- ◆ Unscrew and remove the screw (2).
- ◆ Unscrew and remove the screws (3).
- ◆ Remove the fuel level sensor (4).

NOTE When reassembling, position the terminals of the electric cables correctly, in the relevant fastening positions, using the screws (2) (3).

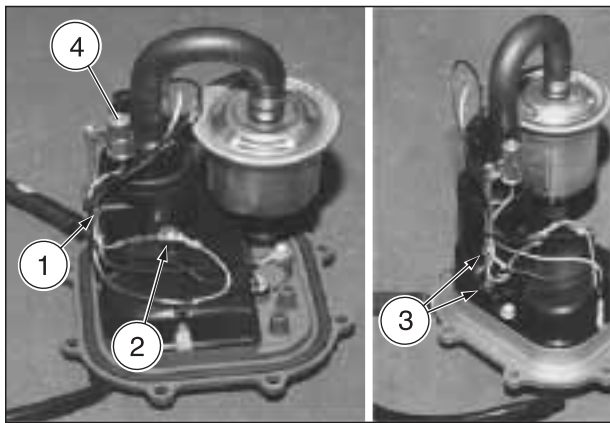

4.5 REMOVING THE DELIVERY FILTER

- ◆ Remove the whole fuel supply pump unit, see 4.3 (REMOVING THE WHOLE FUEL SUPPLY PUMP UNIT).

NOTE Have the appropriate special tool **Opt** to hand:
 – **aprilia** part# 0277295 (hose clamp installation pliers).

⚠ CAUTION

Upon installation, replace the hose clamp that has been removed with a new one having the same dimensions, see 0.4.2 (SPARE PARTS CATALOGUES).

Do not attempt to reinstall the removed hose clamp, since it is unusable.

Do not replace the removed hose clamp with a screw clamp or with other types of clamp.

- ◆ Release the hose clamp (5).
- ◆ Slip the pipe (6) off the filter (7).
- ◆ Release the hose clamp (8).
- ◆ Slip the filter (7) off the pipe (9).

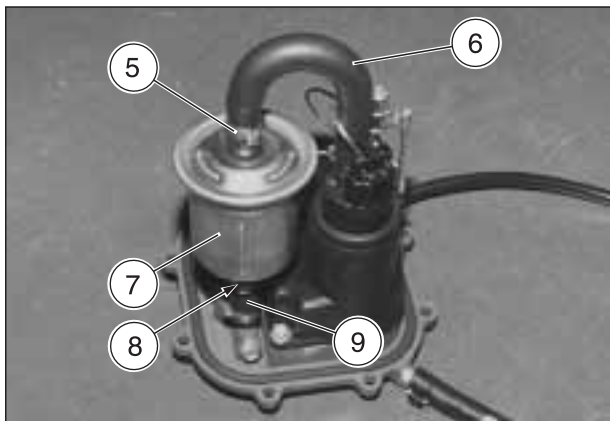

⚠ CAUTION

Do not use filters that have already been used.

- ◆ Replace the filter (7) with a new one of the same type.

4.6 REMOVING THE FUEL SUPPLY PUMP

- ◆ Remove the whole fuel supply pump unit, see 4.3 (REMOVING THE WHOLE FUEL SUPPLY PUMP UNIT).

NOTE Have the appropriate special tool **OPT** to hand:
 – aprilia part# 0277295 (hose clamp installation pliers).

⚠ CAUTION

Upon installation, replace the hose clamp that has been removed with a new one having the same dimensions, see 0.4.2 (SPARE PARTS CATALOGUES).

Do not attempt to reinstall the removed hose clamp, since it is unusable.

Do not replace the removed hose clamp with a screw clamp or with other types of clamp.

- ◆ Release the hose clamp (1).
- ◆ Pull the fuel pipe (3) off the pump (2).
- ◆ Disconnect the electric connector (4).

⚠ CAUTION

When reassembling, make sure the electric connector (4) is plugged in properly.

- ◆ Unscrew and remove the screws (5).

⚠ CAUTION

When performing the operations below, take care not to entangle the electric cables.

- ◆ Bend the fuel filter (6) over sideways (**Pos.A**) and keep it held down.
- ◆ Lift the pump mount (7) just enough to be able to slide out the fuel pump (2).
- ◆ Slide the fuel pump (2) off the mount (7) and recover the O-ring (8).

⚠ CAUTION

If the rubber element (9) supporting the pump proves damaged, replace it.

If the filtering mesh (10) features traces of sediments, clean it using a compressed air jet directed so that the impurities do not get inside.

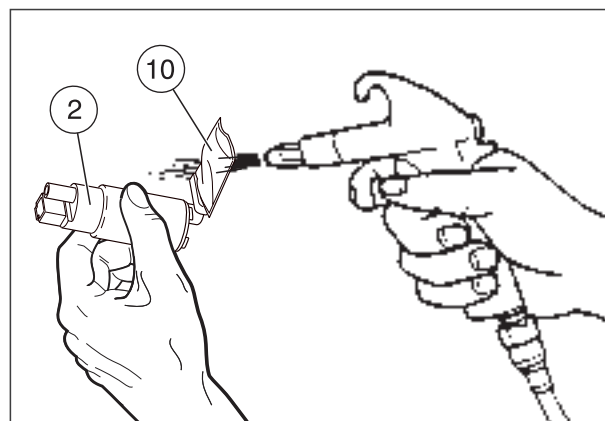
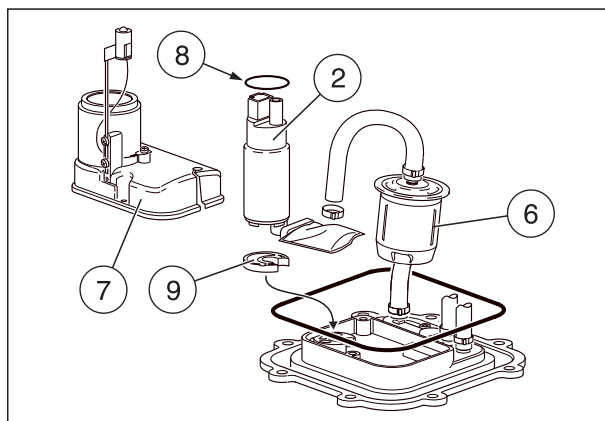
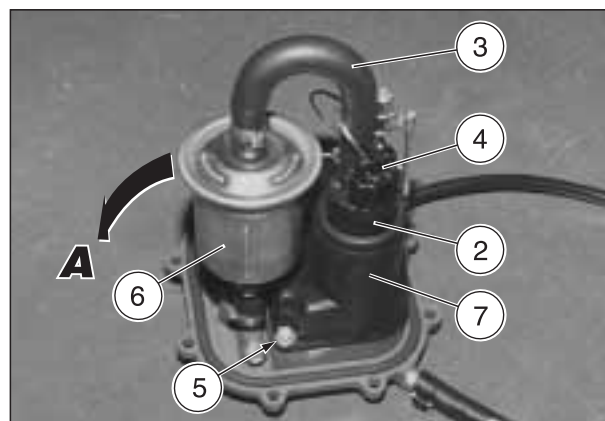
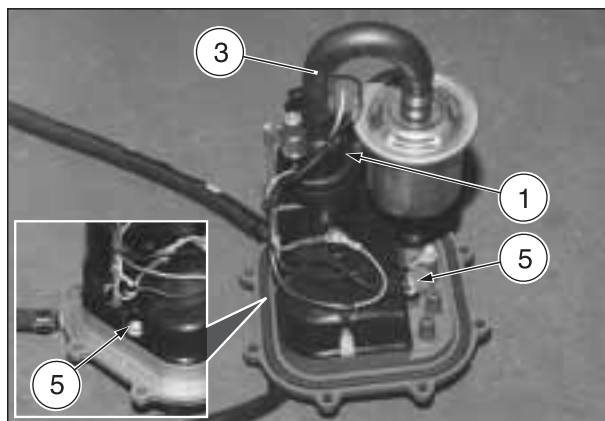

4.7 ENGINE MANAGEMENT

4.7.1 FOREWORD

The “heart” of the engine’s management consists in the electronic Engine Control Unit which manages and optimizes the ignition and injection of the fuel.

- The electronic control unit detects the exact spark angle from the engine rpm and the position of the throttle valves (quantity of air).
- The engine control unit manages the injection time (quantity of fuel) based on the rpm signal, the throttle valve signal (quantity of air, pressure of induction pipe) and correction factors of the various sensors.
- Every time the engine is switched on, the engine control unit checks the sensors and ignition coils, making sure they are working correctly. If any anomalies are encountered, the message “E F I” flashes on the display.
- The safety devices inside the engine control unit stop ignition and the injection of the fuel when the speed exceeds the permissible peak rpm, which is 10500 rpm, or if the vehicle falls over.
When the vehicle is set on the side stand and a gear is engaged, ignition is stopped, preventing the vehicle from starting.

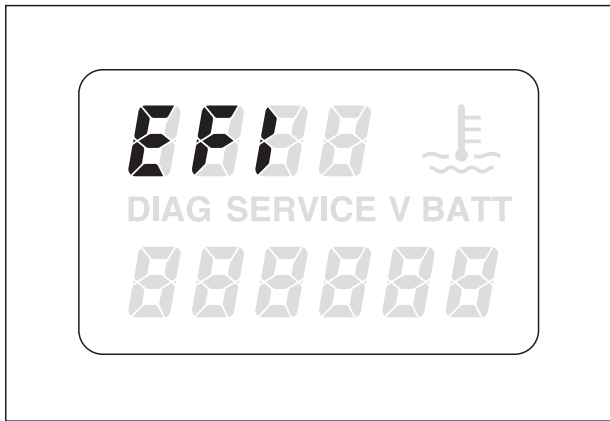

CAUTION

Any modifications or variations made to the exhaust system, intake system or the engine control unit may result in serious damage to the engine. The assembly, modification or use of non-original parts shall cause any warranty to become void and shall exempt the manufacturer from any liability.

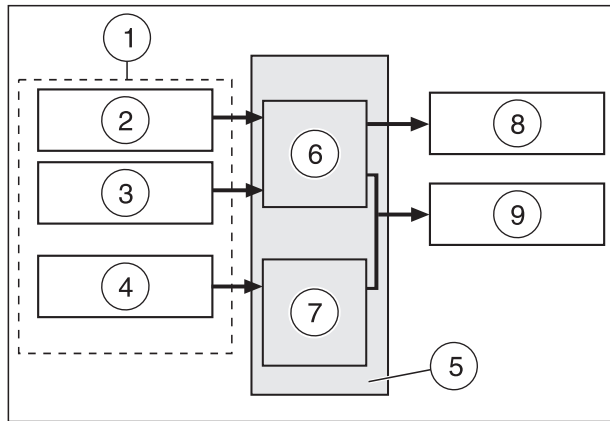

Key

- 1) Signals
- 2) Driving shaft position sensor (engine rpm)
- 3) Throttle valve potentiometer (position of the throttle valves)
- 4) Other sensors
- 5) Electronic unit
- 6) Standard data
- 7) Correction factors
- 8) Ignition coil (ignition angle)
- 9) Injector (injection time)

4.7.2 SENSORS

Driving shaft position sensor (2)

Location: in the flywheel cover (10)

The sensor detects the number of teeth present on the rotor.

The engine speed and the position of the driving shaft are calculated based on the signals emitted.

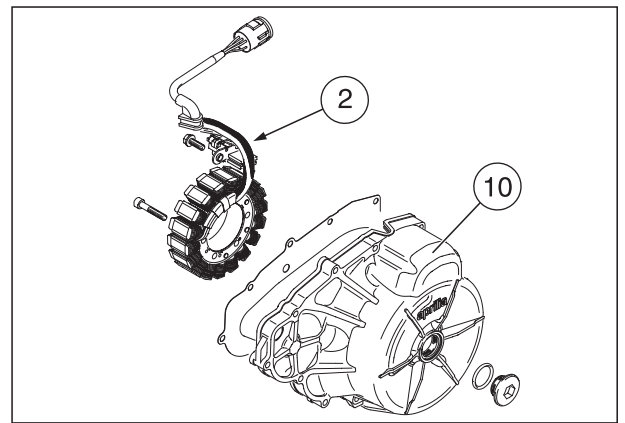

Camshaft position sensor (11)

Position: in the front cylinder head (12).

The signal is sent out through the identification of a tooth present on the exhaust camshaft sprocket.

This signal makes it possible to detect the current engine stroke.



Intake pressure sensor (13)

Location: in the intake manifold.

The pressure measured in the induction pipe is converted into a voltage signal.

Moreover, the injection time also depends on the induction pipe pressure, especially when the throttle valve opening angle is limited (during idling).

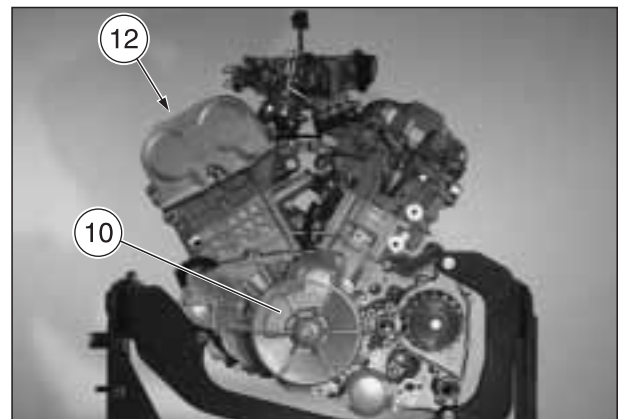

Throttle valve potentiometer (3)

Location: on the throttle body (14).

The throttle valve potentiometer measures the position of said valves and acts as the main parameter in determining the injection time and ignition angle.

Follow ►

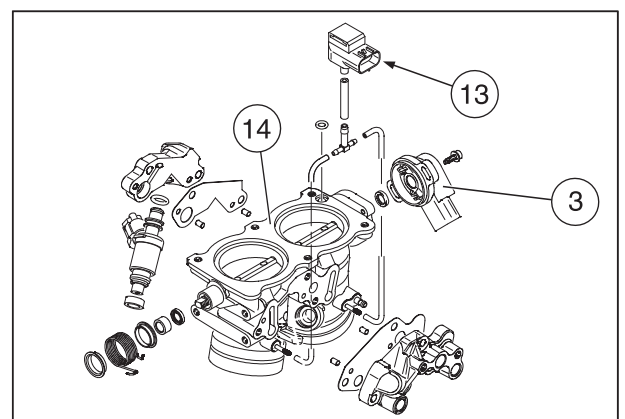

Follow ►

Coolant thermistor (15)

Location: on rear head cylinder (16).

The temperature sensor detects the coolant temperature and is required to correct the injection time. The injection time is increased if the coolant has not yet reached the working temperature.

Atmospheric pressure sensor

Location: inside the engine control unit (5).

The intake pressure measured by the sensor is converted into a voltage signal and is required by the engine control unit to correct the injection time.

Air thermistor

Location: in the intake pipe of the left-hand air conveyor.

The resistance measured by the thermistor is converted into a voltage signal and is required by the engine control unit to correct the injection time.

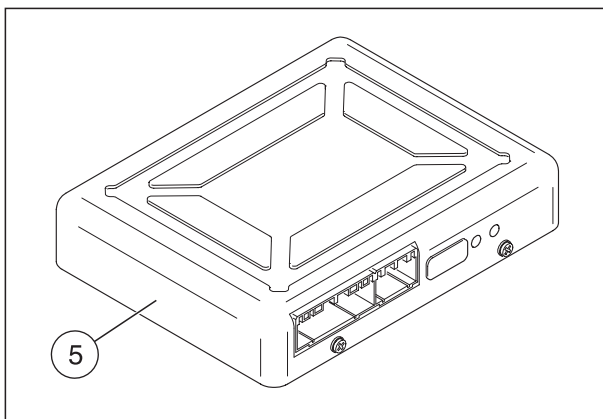
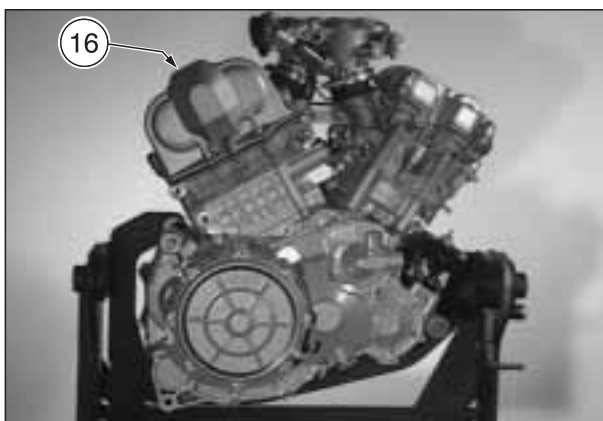

4.7.3 INJECTION SYSTEM DIAGRAM

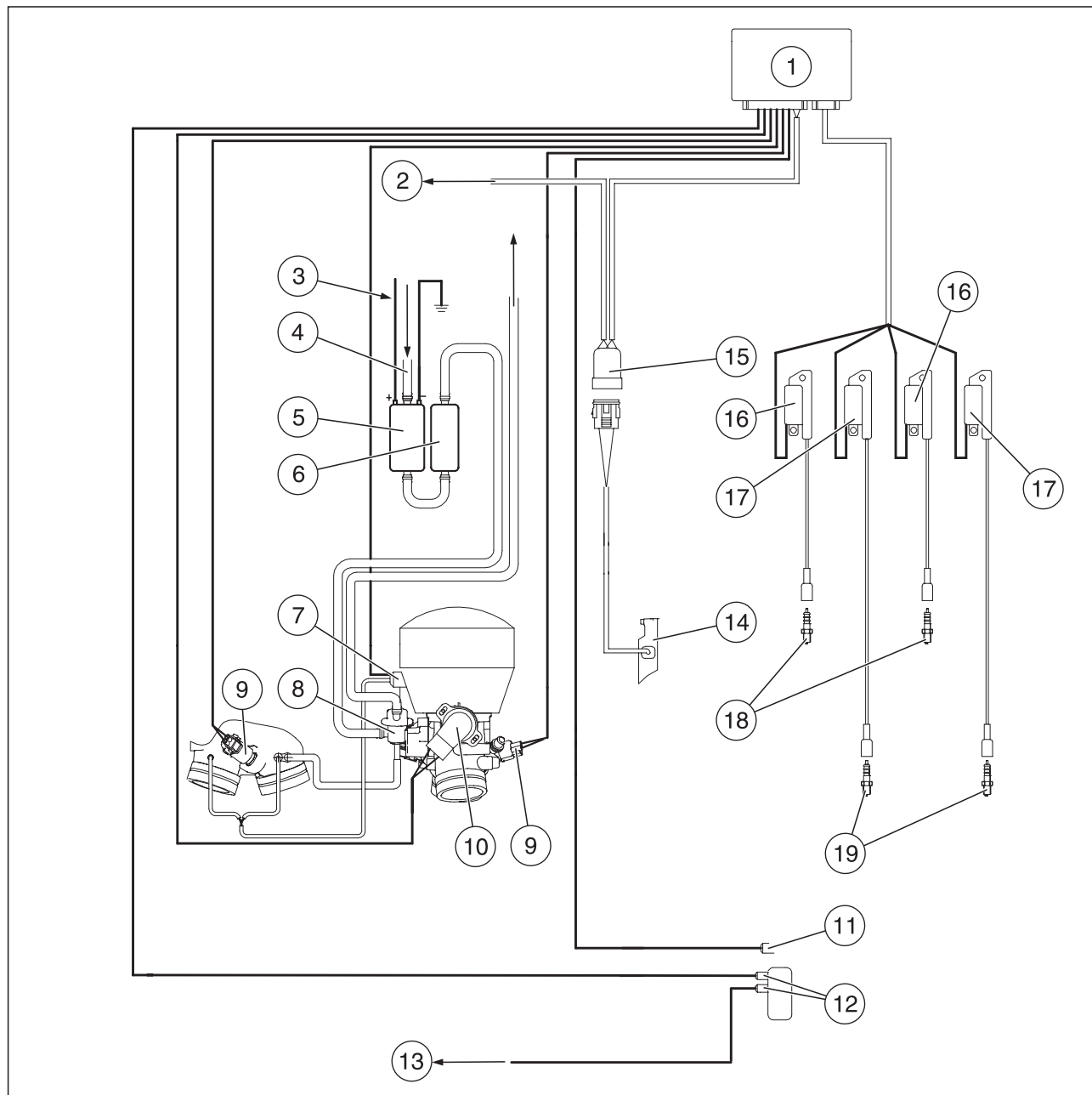

Key

- | | |
|--|---|
| <ul style="list-style-type: none"> 1) Electronic unit 2) To voltage regulator 3) Supply voltage 4) Fuel suction from tank 5) Fuel pump 6) Fuel filter 7) Intake pressure sensor 8) Fuel pressure regulator 9) Injectors 10) Throttle valve potentiometer 11) Camshaft position sensor | <ul style="list-style-type: none"> 12) Coolant temperature thermistors. 13) To multifunction display, right-hand side 14) Driving shaft position sensor and generator 15) Driving shaft position sensor and generator connector 16) HV ignition coil cylinder "1" (front) 17) HV ignition coil cylinder "2" (rear) 18) Spark plug cylinder "1" (front) 19) Spark plug cylinder "2" (rear) |
|--|---|

4.7.4 ENGINE CONTROL UNIT CONNECTORS

For further information, see 6.17 (CONNECTIONS TO THE ENGINE CONTROL UNIT).

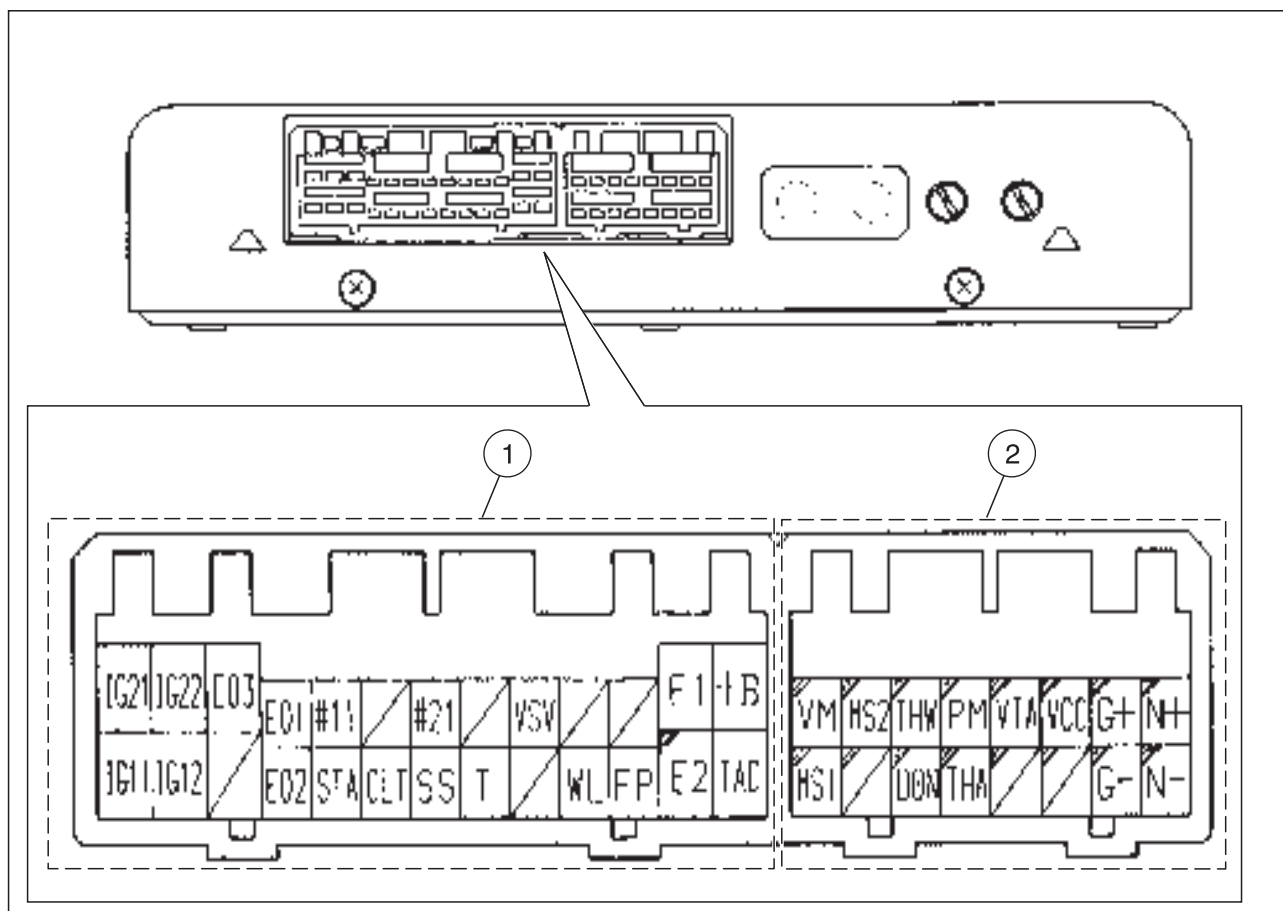

26-pin connector (1)	
Terminal labeling	Connections
+ B	Battery connection positive pole “+”
E 1	Earth (for control circuit)
VSV	Empty
# 21	Rear cylinder injector
# 11	Front cylinder injector
E 01	Earth
E 03	Earth
IG 22	Rear cylinder ignition coil
IG 21	Rear cylinder ignition coil
TAC	Revolution counter
E 2	Sensor earth
FP	Fuel pump relay
WL	Multifunction display
T	Test (automatic fault search, dealer mode)
SS	Side stand switch
CLT	Clutch control lever switch
STA	Starter motor relay
E 02	Earth
IG 12	Front cylinder ignition coil
IG 11	Front cylinder ignition coil

16-pin connector (2)	
Terminal labeling	Connections
N +	Driving shaft position sensor “+”
G +	Camshaft position sensor
VCC	Intake pressure sensor and throttle valve potentiometer
VTA	Throttle valve potentiometer
PM	Intake pressure sensor
THW	Coolant thermistor
MS 2	Earth
VM	Fuel pump
N -	Driving shaft position sensor “-”
G -	Camshaft position sensor
THA	Air thermistor - Intake pressure sensor
DON	Fall sensor
MS 1	Earth

4.7.5 AUTOMATIC TESTING

See 6.4 (IGNITION SYSTEM).

4.7.6 ELIMINATING ELECTRONIC SYSTEM FAULTS ACCORDING TO THE INFORMATION SENT UP ON THE DISPLAY

⚠ WARNING

Take care around the high voltage in the ignition system.

Never disconnect connections with the engine running.

Whenever work is performed in the ignition system, always make sure the ignition switch is set to “

⚠ CAUTION

All measurements must be taken with the components at a temperature of 20 °C (68 °F).

General instructions regarding the elimination of faults: as soon as the fault has been located, remove the defective component.

4.7.7 CAMSHAFT POSITION SENSOR

Fault code “11”.

See 6.4.6 (CHECKING THE CAMSHAFT POSITION SENSOR).

4.7.8 DRIVING SHAFT POSITION SENSOR

Fault code “12”.

See 6.4.5 (CHECKING THE PICK-UP).

4.7.9 INTAKE PRESSURE SENSOR

Fault code “13”.

See 6.4.11 (CHECKING THE INTAKE PRESSURE SENSOR).

4.7.10 INTAKE PRESSURE SENSOR

Fault code “14”.

- ◆ Check for pressure loss in the connection pipes (1) (2) (3) and make sure the flow is regular.
- ◆ Check the wiring and connections of the pressure sensor.

NOTE Where necessary, replace the pressure sensor or engine control unit.

4.7.11 THROTTLE VALVE POTENTIOMETER

Fault code “15”.

See 6.4.10 (CHECKING THE THROTTLE VALVE POTENTIOMETER).

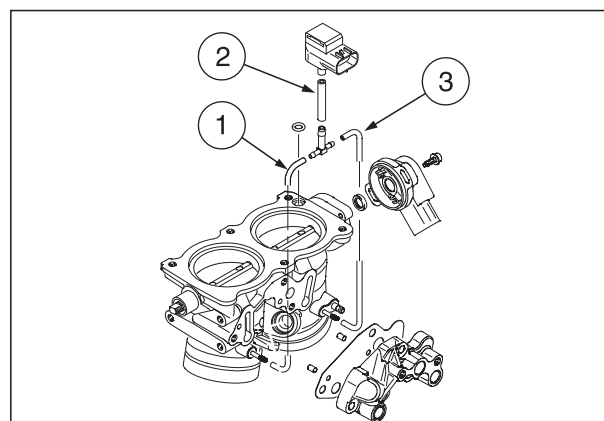
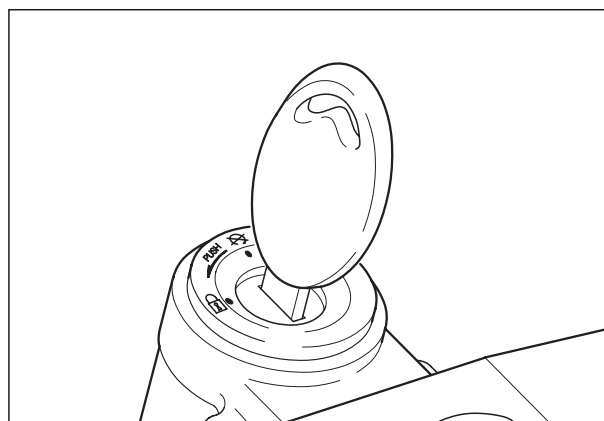

4.7.12 COOLANT THERMISTORS

Fault code “21”.

See 6.4.8 (CHECKING THE COOLANT THERMISTOR OPERATION).

4.7.13 AIR THERMISTOR

Fault code “22”.

See 6.4.9 (CHECKING THE AIR THERMISTOR OPERATION).

4.7.14 IGNITION COILS

Fault code “33”, “34”, “35”, “36”.

See 6.4.4 (CHECKING THE IGNITION COILS).

4.8 THROTTLE BODY

⚠ CAUTION

The screws (1) for the standard adjustment of the throttle valves and for increasing idling (2) are painted and cannot be adjusted.

Only when the whole cable support bracket (3) is replaced can the two adjusting screws be turned.

The two M4x12 screws (4) fastening the throttle valve potentiometer are painted and can only be removed in the event the actual sensor is replaced.

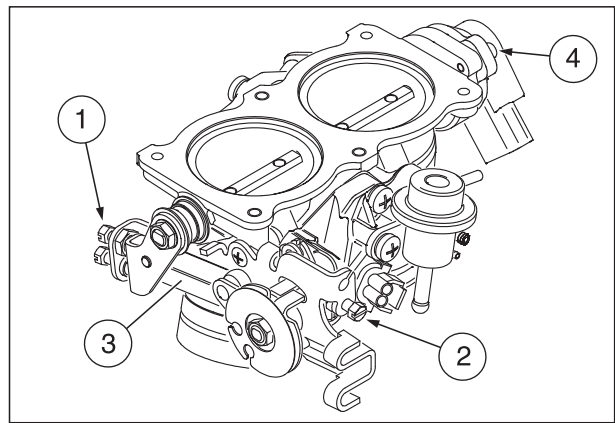

4.8.1 REMOVING THE INJECTORS

See 4.8.2 (REMOVING THE THROTTLE BODY).

See 6.4.12 (CHECKING THE INJECTORS) for the checking procedure.

4.8.2 REMOVING THE THROTTLE BODY

Carefully read 0.5.1 (PRECAUTIONS AND GENERAL INFORMATIONS).

- ◆ Partially remove the fuel tank, see 7.1.5 (PARTIAL REMOVAL OF THE FUEL TANK).
- ◆ Remove the air filter casing, see 7.1.7 (REMOVING THE AIR CLEANER CASE).
- ◆ Disconnect the electric connectors:
 - right injector (5);
 - left injector (6);
 - intake pressure sensor (7);
 - throttle valve potentiometer (8).

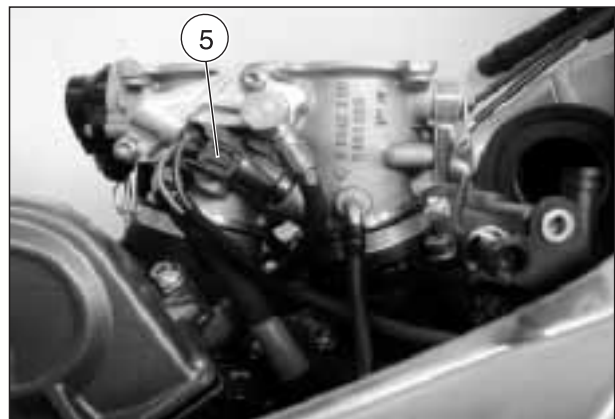
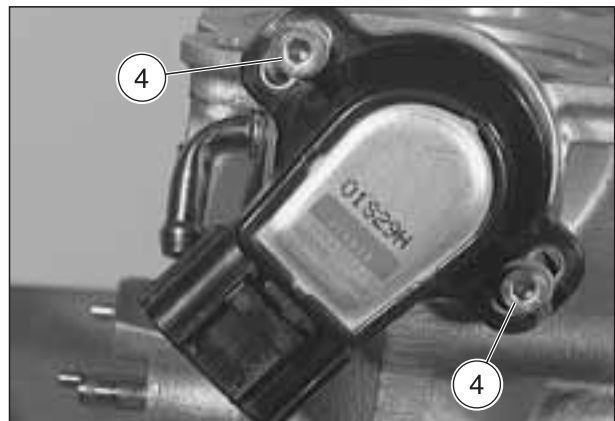

⚠ CAUTION

When reassembling, make sure the electric connectors are plugged in properly.

Follow ►

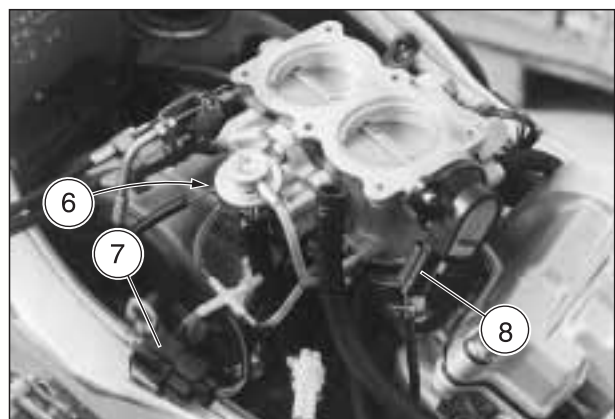

Follow ►

NOTE Have the appropriate special tool **OPT** to hand:
 – aprilia part# 0277295 (hose clamp installation pliers).

⚠ CAUTION

Upon installation, replace the hose clamp that has been removed with a new one having the same dimensions, see 0.4.2 (SPARE PARTS CATALOGUES).

Do not attempt to reinstall the removed hose clamp, since it is unusable.

Do not replace the removed hose clamp with a screw clamp or with other types of clamp.

- ◆ Release the hose clamp (9).
- ◆ Release the hose clamp (10).
- ◆ Pull the pipes (12) (13) off the throttle body (11).
- ◆ Disconnect the two throttle cables (14) (15).

⚠ CAUTION

Upon reassembly, make sure that the two accelerator cable adjusters are properly fastened to the corresponding couplings; check and if necessary restore the correct slack, see 2.11.3 (ADJUSTING THE ACCELERATOR CONTROL).

- ◆ Disconnect the cold-start control cable (16).

⚠ CAUTION

When reassembling, make sure the cold-start control cable adjuster is properly fastened to the respective coupling and check and, where necessary, restore the correct freeplay, see 2.12 (COLD START CABLE).

- ◆ Loosen the two clamps (17) (18).

⚠ CAUTION

When removing the throttle body (11), be careful to make sure it remains connected to the fuel tank (20) by means of the fuel pipe (19).

- ◆ Grip the throttle body (11) firmly and hitch it one way and the other to lift it and slide it off the intake flanges.
- ◆ Place the whole throttle body (11) and fuel tank (20), still connected together, on a clean surface.

⚠ CAUTION

Upon reassembly:

- the fuel delivery pipe (19) must not be entangled or positioned where it is likely to be squashed by other components; should it appear damaged or deteriorated, it must be replaced;
- the fuel delivery pipe (19) must be placed so that it reaches the right-hand side of the throttle body (11), passing under said body between the two intake flanges;
- the throttle body (11) must be fitted perfectly on the intake flanges;
- the clamps (17) (18) must be properly tightened.

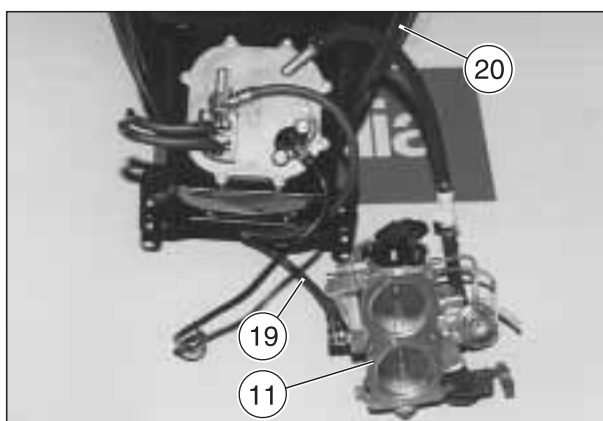
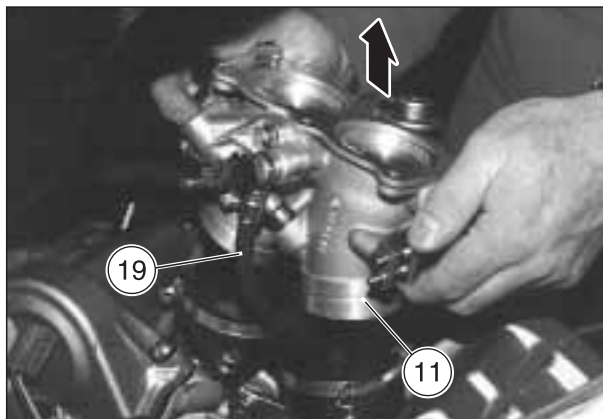
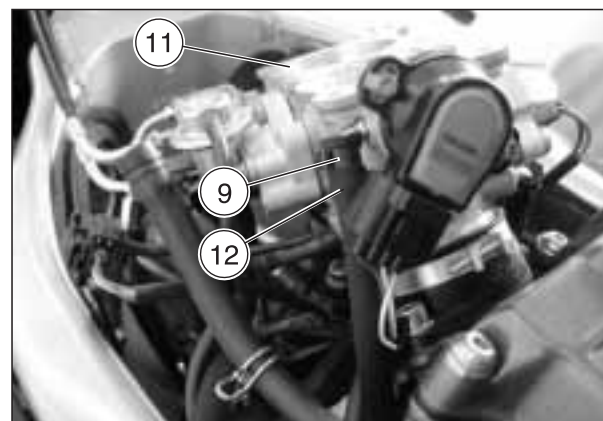
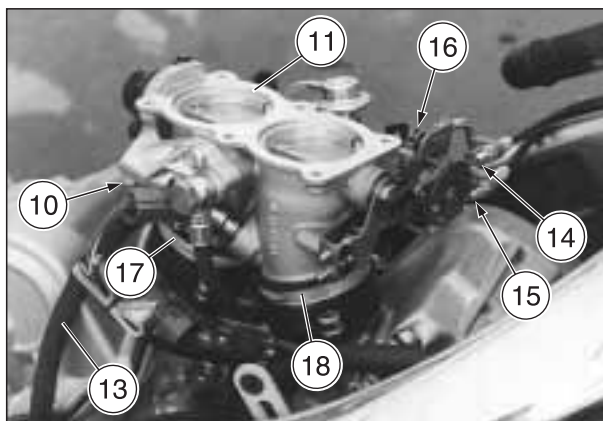

4.8.3 DISASSEMBLING THE THROTTLE BODY

Carefully read 0.5.1 (PRECAUTIONS AND GENERAL INFORMATIONS).

- ◆ Unscrew and remove the M8x1 nut (1) and remove the spring washer.
- ◆ Turn the throttle valve control lever (2) slightly, unscrew and remove three T.E. M5x12 screws (3).
- ◆ Slip the whole support bracket (4) securing the throttle cables, with the two bushes (5) and the torsion spring (6), off the throttle body.
- ◆ Unscrew and remove the two M6x16 screws (7) and remove the fuel pressure regulator (8) complete with O-ring.
- ◆ Unscrew and remove the three M6x25 screws (9) and remove the left injector support (10) - together with the relevant gasket (11), injector (12) and sealing ring (13) - from the throttle body.

Follow ►

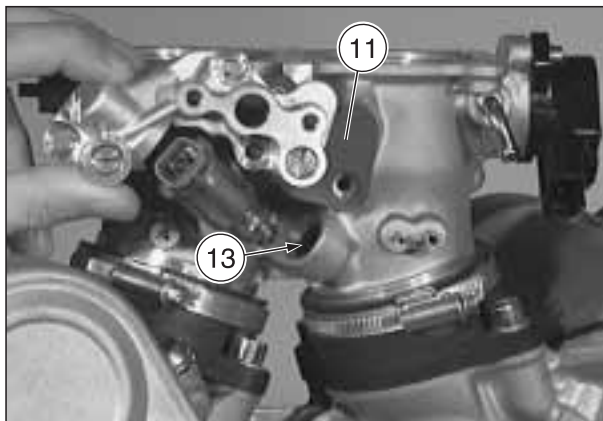
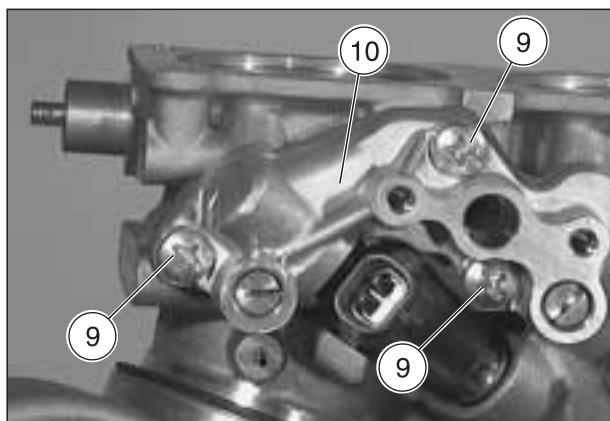
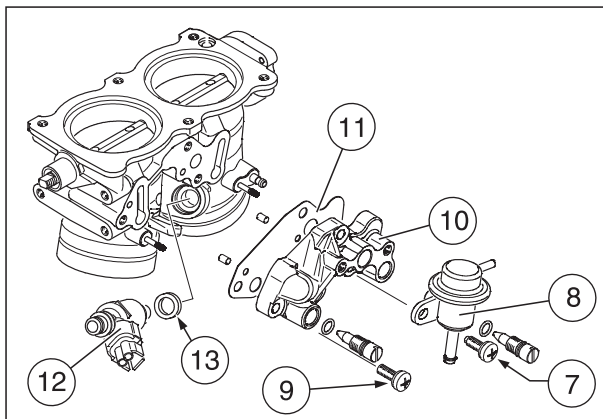
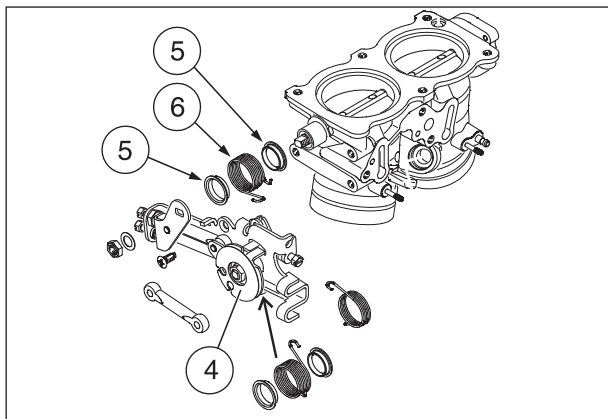
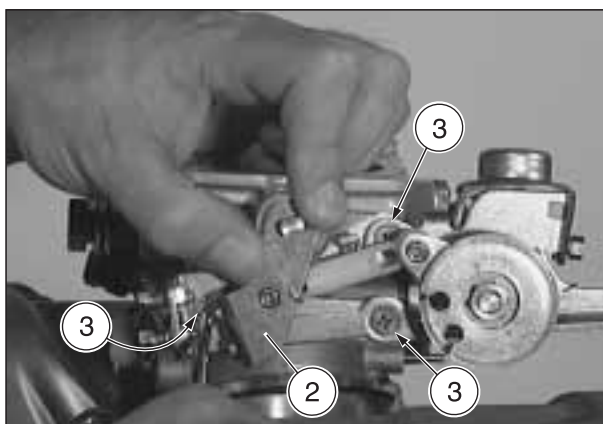

Follow ►

- ◆ Unscrew and remove the two M6x25 screws (14) and the right injector support (15), together with the relevant gasket (16), injector (17) and sealing ring (18).

NOTE The injector's sealing ring (18) may be kept inserted in the slot on the throttle body.

- ◆ Unscrew and remove the M8x1 nut (19) and remove the spring washer (20), the pulley (21), the two bushes (22) and torsion spring (23).
- ◆ Slide the fulcrum pin (24), together with the lock washer (25), out of the hole on the throttle cable support bracket and remove the two shaft sealing rings (26) with the torsion spring (27) and cold-start lever (28).

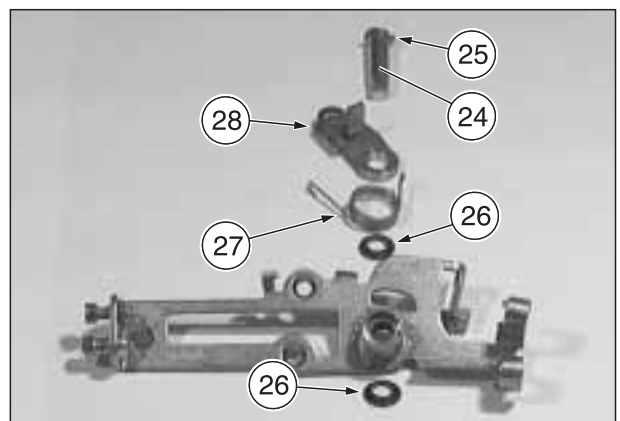
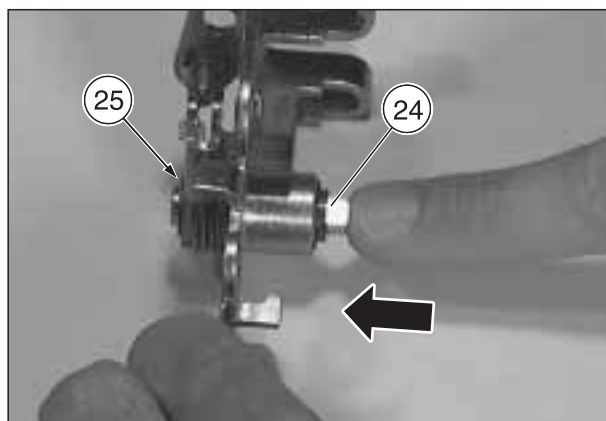
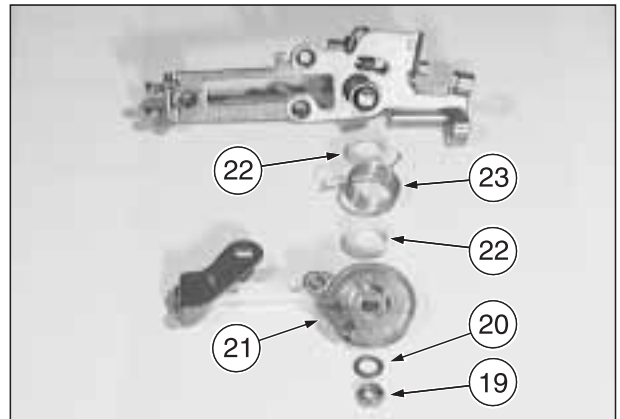
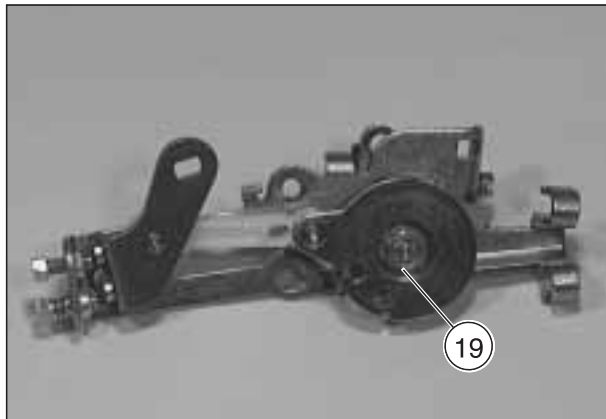
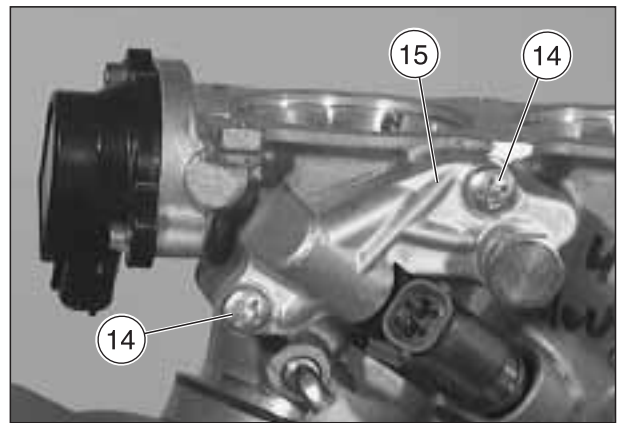
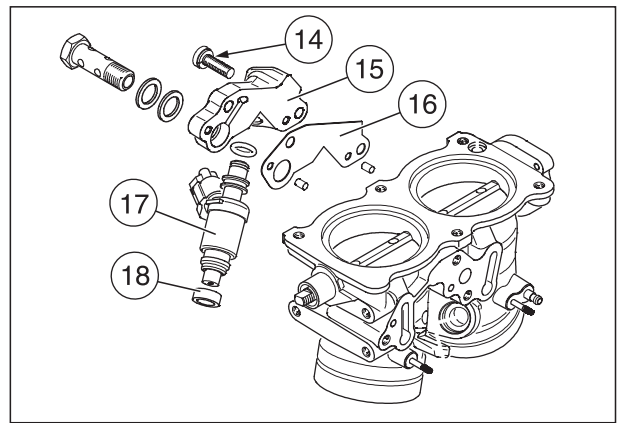

4.8.4 INSPECTING THE THROTTLE BODY

TESTING THE INJECTOR

⚠ WARNING

The fuel is explosive and highly inflammable. Keep fuel away from ignition sparks, heat and flames.

NOTE The injectors can be controlled electrically.

- ◆ Check the following components:
 - wiring and connections;
 - injector or injection signal of the engine control unit, see 6.4 (IGNITION SYSTEM).

Checking injector resistance:

See 6.4.12 (CHECKING THE INJECTORS).

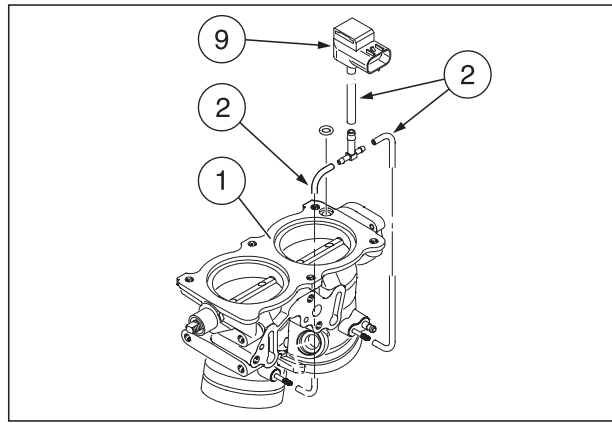

THROTTLE BODY

⚠ CAUTION

Use neutral detergents only. For cleaning, use a product for removing sealing, a degreasing product or a detergent for cleaning when cold.

- ◆ Clean all the openings and pipes of the throttle body (1) using compressed air.

⚠ CAUTION

Once the intake pressure sensor (9) is installed, not utilize the compressed air for the pipes cleaning; danger for damages.

- ◆ Check the pipes of the intake pressure sensor (2), watching out for any clogging.
- ◆ Check the throttle valves unit and the cable fastening mechanism (3), watching out for any signs of mechanical damage.

NOTE In the event the synchronization screws (4) or O-rings (5) are replaced, synchronize the cylinders, see 4.8.10 (CYLINDER SYNCHRONIZATION).

- ◆ Unscrew the two cylinder synchronization screws (4) only in case of air escapes.
- ◆ When replacing the tie rod of the ball joint (6), disengage the tie rod from the throttle valve control lever (7) and throttle cable pulley (8).
- ◆ Once a new ball joint tie rod (6) has been fitted, make sure it moves freely.

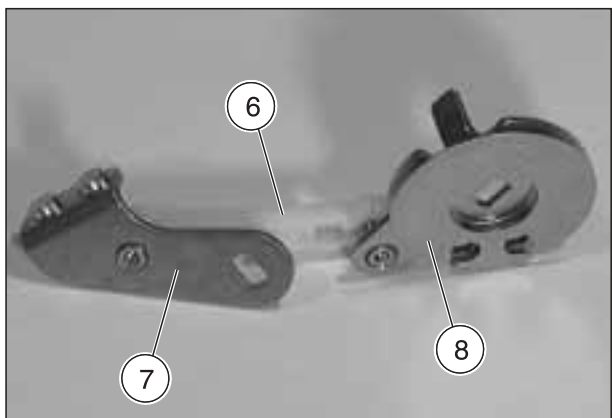
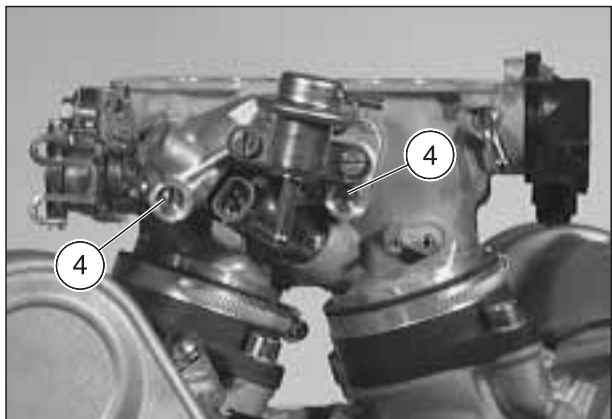
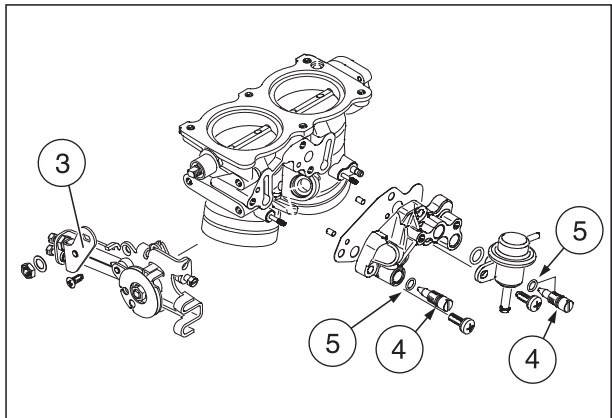

4.8.5 REFITTING THE THROTTLE BODY

Carefully read 0.5.1 (PRECAUTIONS AND GENERAL INFORMATIONS).

⚠ CAUTION

After disassembling the throttle body, replace all the gaskets, O-rings, torsion springs, bushes and seals. These components are supplied with the repair kit.

- ◆ Fit the new O-rings (1) and seals (2) on both injector.
- ◆ Insert the injector (3) in the left injector support (4) and in the right injector support (5).
- ◆ Fit the left injector support gasket (6), right injector support gasket (7) and the two seals (8) on the throttle body.
- ◆ Install the complete left injector support (4) and right injector support (5) in the throttle body, fastening them with the new M6x25 (9) (10) screws respectively.

Screws (9) (10) driving torque: 9 Nm (0.9 kgm).

- ◆ If the synchronizing screws (11) and respective O-rings (12) have been replaced, screw on the screws (11) fairly tight until they touch the stop and then unscrew them a single turn.

Presetting of synchronizing screws (11): 1 turn.

⚠ CAUTION

The precise adjustment of the screws (11) must be performed using a vacuum gauge, see 4.8.10 (CYLINDER SYNCHRONIZATION).

- ◆ Fasten the fuel pressure regulator (13) using the two M6x16 screws (14).

Screws (14) driving torque: 3.5 Nm (0.35 kgm).

NOTE Smear a film of grease over the surfaces of the fulcrum pin (18), see 1.6 (LUBRICANT CHART).

- ◆ Insert the cold-start lever (15), torsion spring (16) and shaft sealing ring (17) on the fulcrum pin (18).
- ◆ Insert the complete fulcrum pin (18) in the throttle cable support bracket.

Follow ►

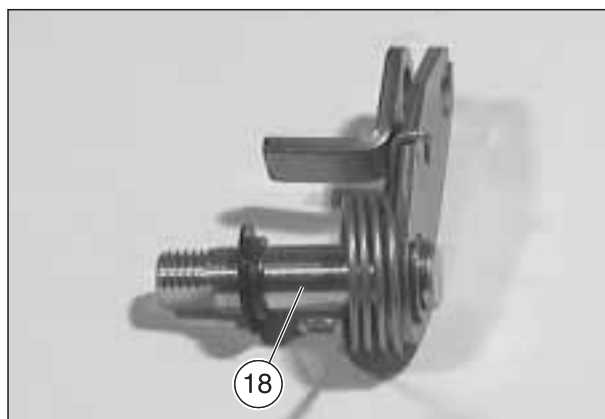
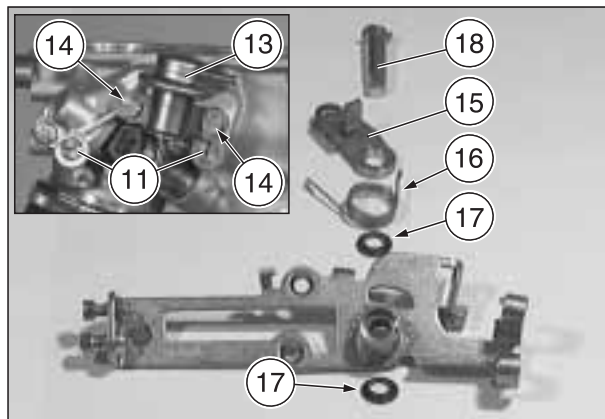
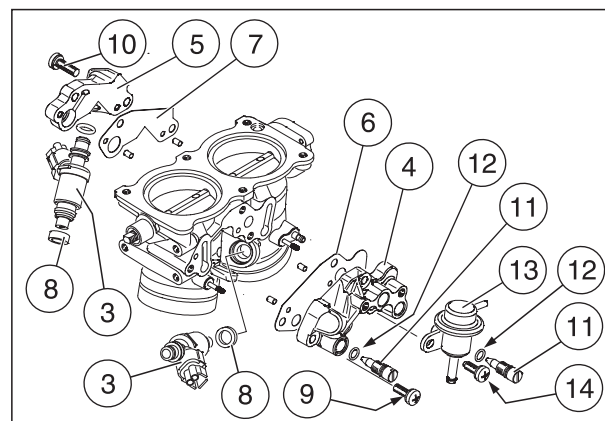
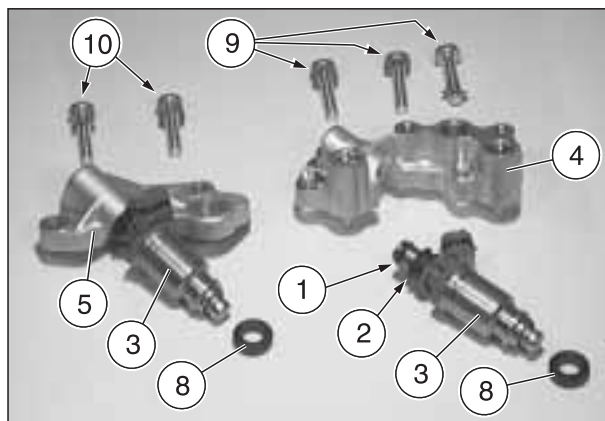

Follow ►

NOTE Make sure the torsion spring is hooked to the cold-start lever (15) and cable support bracket.

- ◆ Spray chain grease onto the spring (16), see 1.6 (LUBRICANT CHART).
- ◆ Insert the shaft sealing ring (17) on the fulcrum pin (18).
- ◆ Fit the two bushes (19) and torsion spring (20).
- ◆ Fit the pulley (21) on the throttle cable support bracket.

CAUTION

Make sure that the ends of the torsion spring (20) are hooked onto the throttle cable support bracket and pulley (21).

NOTE Spray a temporary lubricant on the spring (20), see 1.9.2 (USE OF CONSUMABLES).

- ◆ Fit the spring washer (22).

NOTE Apply LOCTITE® 243 on the thread of the nut (23).

- ◆ Screw the M8x1 nut (23) and tighten it.

Nut (23) driving torque: 3 Nm (0.3 kgm).

NOTE Apply LOCTITE® 243 on the thread of the screws (25).

- ◆ Fasten the anchoring bracket of the accelerator cables (24) with the three hex-head screws M5x12 (25).

Screws (25) driving torque: 3 Nm (0.3 kgm).

- ◆ Fit the throttle valve control lever (26), see 4.8.6 (REPLACING THE THROTTLE VALVE CONTROL LEVER).

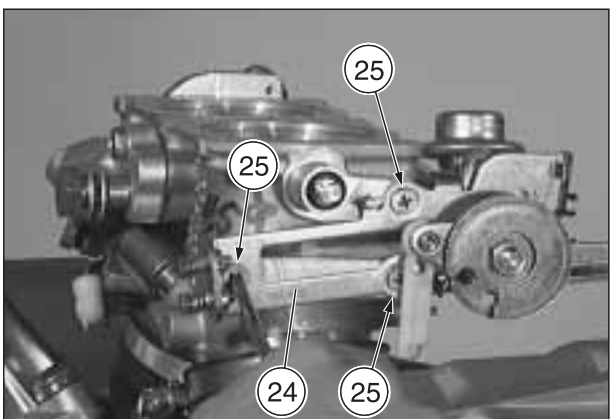
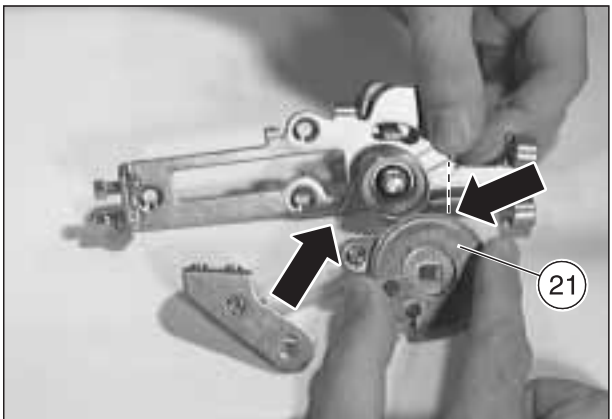
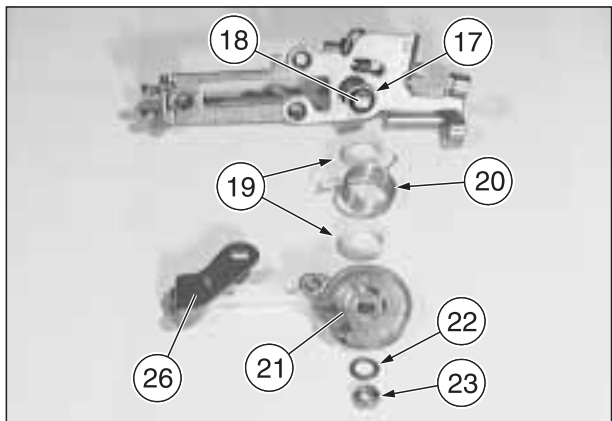
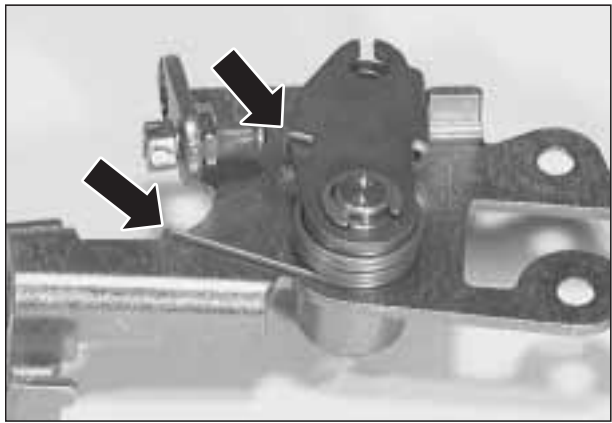

4.8.6 REPLACING THE THROTTLE VALVE CONTROL LEVER

Carefully read 0.5.1 (PRECAUTIONS AND GENERAL INFORMATIONS).

DISASSEMBLY

- ◆ Partially remove the fuel tank, see 7.1.5 (PARTIAL REMOVAL OF THE FUEL TANK).
- ◆ Remove the air filter casing, see 7.1.7 (REMOVING THE AIR CLEANER CASE).
- ◆ Unscrew and remove the M8x1 nut (1) and remove the spring washer.
- ◆ Slide out the control lever (2) and retrieve the two bushes (3) and torsion spring (4).
- ◆ Remove the control lever (2) from the tie rod of the ball joint (5).

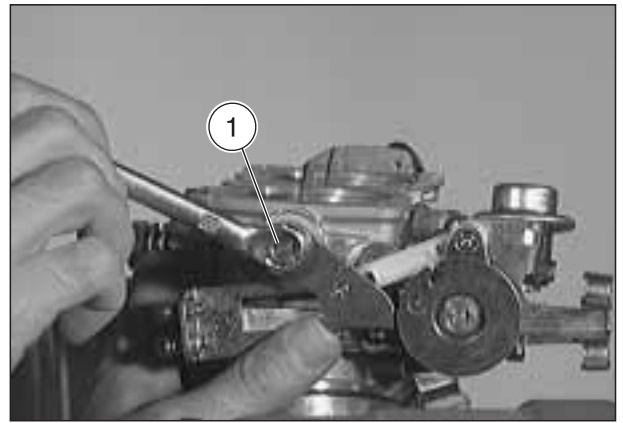

ASSEMBLY

⚠ CAUTION

For the vehicles with the following engine numbers, the throttle valve control lever (2) must be replaced with the new grey-coloured lever.

523579	525113 - 525118	525443 - 525597
523582	525120 - 525124	525605
523587	525126 - 525139	525609
523590 - 523592	525141 - 525148	525621
523594 - 523602	525150 - 525236	525629 - 525631
523604	525238 - 525275	525633 - 525635
523607 - 523609	525277 - 525278	525639
523612 - 523618	525280 - 525295	525641 - 525645
523621	525300 - 525302	525647 - 525648
523623 - 523624	525306 - 525321	525651
523626 - 523635	525324 - 525327	525653 - 525654
523637 - 523640	525329 - 525331	525657
523643	525344	525659
523645	525346 - 525347	525662
523648 - 523651	525350 - 525351	525665
523654 - 523656	525356 - 525358	525667
523658 - 523660	525365	525676 - 525681
523662 - 523673	525368 - 525371	525684
523675 - 523676	525373 - 525374	525686 - 525687
523678 - 523691	525376	525689 - 525690
523693 - 523698	525378	525699
523700 - 523713	525382 - 525387	525704
523715 - 523752	525389	525713
523754 - 523778	525392 - 525404	525731
523780 - 523793	525406	525750
523795 - 523892	525408	525765
523894 - 523948	525410 - 525412	525767
523950 - 523966	525414 - 525420	525883
523970 - 524610	525422	526070
524612 - 524679	525424 - 525427	526075
524683 - 524686	525430	526235 - 526237
524688 - 524999	525432 - 525435	526246 - 526249
525001 - 525007	525439	526254 - 526265
525009 - 525111	525441	—

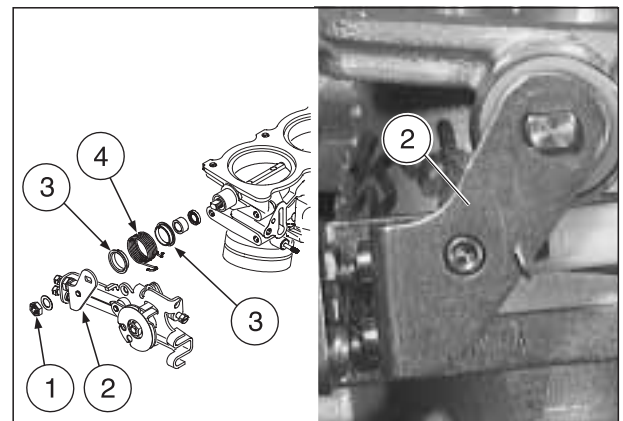
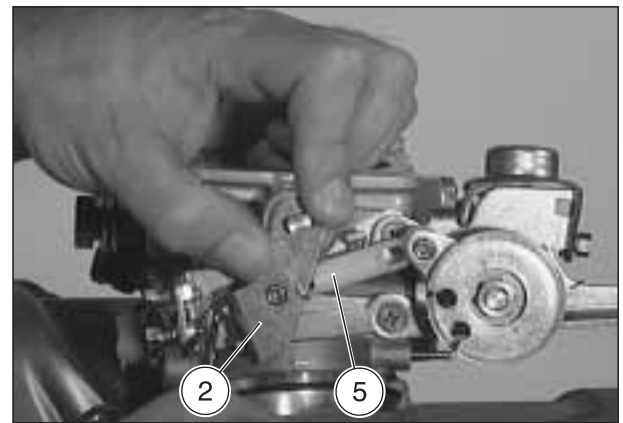

Follow ►

Follow ►

- ◆ Fit the two bushes (3) and torsion spring (4) on the throttle body.
- ◆ Fit the throttle valve control lever (2) on the throttle valve spindle.

NOTE Spray a temporary lubricant on the spring (4), see 1.9.2 (USE OF CONSUMABLES).

CAUTION

Make sure the ends of the torsion spring (4) are hooked onto the throttle body and throttle valve control lever (2).

- ◆ Fit the spring washer.

NOTE Apply LOCTITE® 243 on the thread of the nut (1).

- ◆ Screw the M8x1 nut (1) and tighten it.

Driving torque (1): 3 Nm (0.3 kgm).

NOTE Once assembly is complete, make sure the levers rotate freely.

The throttle valve control lever (2) must be returned to its original position by the torsion spring.

Check for end play on the throttle valve control shaft, see 4.8.7 (CHECKING THROTTLE VALVE CONTROL SHAFT END PLAY) and adjust as necessary, see 4.8.8 (ADJUSTING THE THROTTLE BODY).

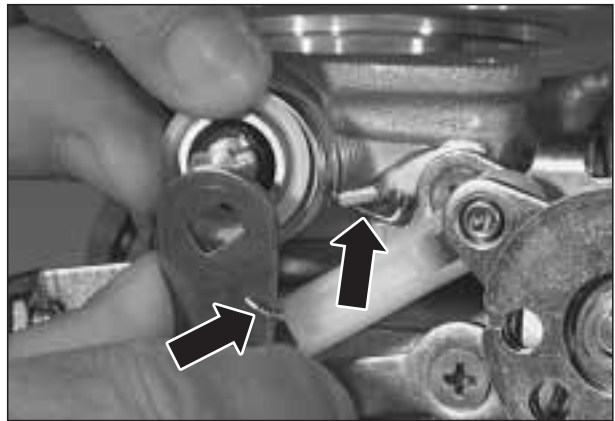
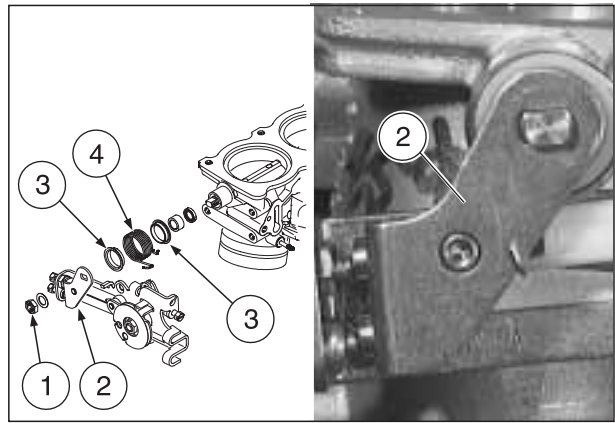

4.8.7 CHECKING THROTTLE VALVE CONTROL SHAFT END PLAY

- ◆ Partially remove the fuel tank, see 7.1.5 (PARTIAL REMOVAL OF THE FUEL TANK).
- ◆ Remove the air filter casing, see 7.1.7 (REMOVING THE AIR CLEANER CASE).

NOTE Have an appropriate thickness gauge (1) to hand with a 0.05 mm scale.

With throttle valves closed:

- ◆ Use the thickness gauge (1) to measure the minimum play between the lever (2) and the contact surface (3) on the throttle body in a number of points.

End play: min. 0.1 mm.

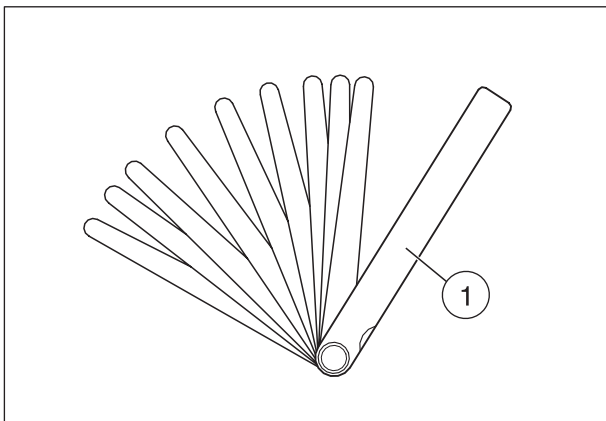

CAUTION

If the minimum value measured is lower than 0.1 mm, the throttle body must be replaced, see 0.4.2 (SPARE PARTS CATALOGUES).

With throttle valves open:

- ◆ Repeat the above procedure.

End play: min. 0.15 mm.

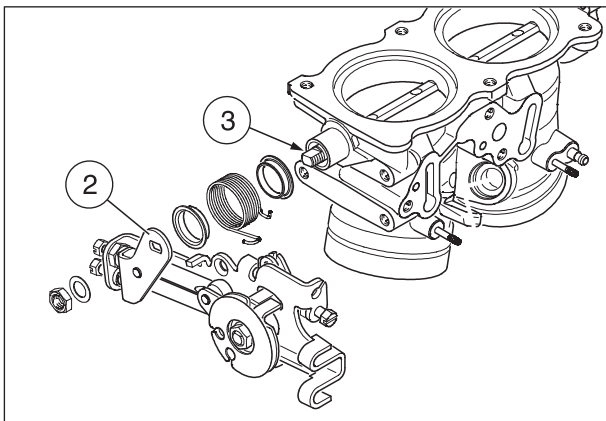

CAUTION

If the minimum value measured is lower than 0.15 mm, the throttle body must be replaced, see 0.4.2 (SPARE PARTS CATALOGUES).

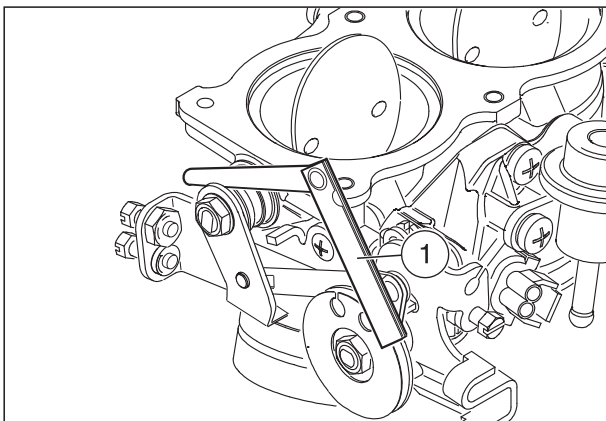
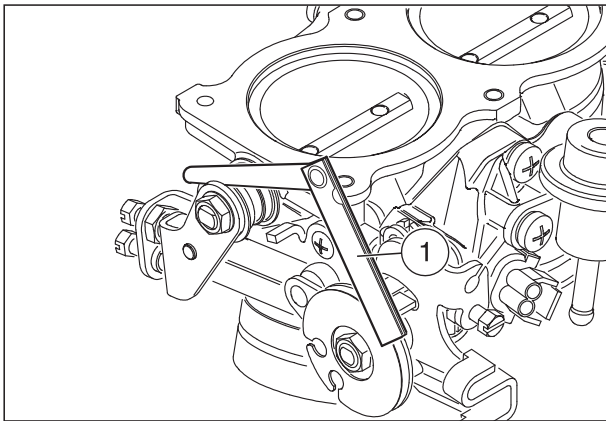

4.8.8 ADJUSTING THE THROTTLE BODY

- ◆ Partially remove the fuel tank, see 7.1.5 (PARTIAL REMOVAL OF THE FUEL TANK).
- ◆ Remove the air filter casing, see 7.1.7 (REMOVING THE AIR CLEANER CASE).

SETTING IDLING

CAUTION

The screw (1) of the throttle valve end of stroke is painted and cannot be adjusted.

Only when the whole throttle cable support bracket is replaced can the adjusting screw (1) be turned again.

- ◆ Loosen the M5x0.5 nut (2).
- ◆ Unscrew the adjusting screw (1) of the throttle valve end of stroke, until the throttle valves (3) adhere to the throttle body (4).
- ◆ Screw the adjusting screw (1) until it touches the stop onto the throttle valve control lever (5), and turn it another 1/2 – 3/4 turn before tightening the M5x0.5 nut (2).

Idling setting: 1/2 – 3/4 turn.

SETTING THE COLD-START DEVICE

CAUTION

When the whole throttle cable support bracket must be replaced, it is necessary to adjust the cold start control screw (6) again, after setting the screw (1) of the throttle valve end of stroke.

NOTE Have an appropriate thickness gauge.

- ◆ Loosen the M5x0.5 nut (7).
- ◆ Pull back the cold-start lever (8) until it touches the screw (6).
- ◆ Adjust the screw (6) so that the clearance between the idling adjusting screw (1) and the throttle valve control lever (5) is in the range 1.6 to 1.8 mm.

Adjustment: 1.6 – 1.8 mm.

- ◆ Secure the screw (6) by tightening the M5x0.5 nut (7).

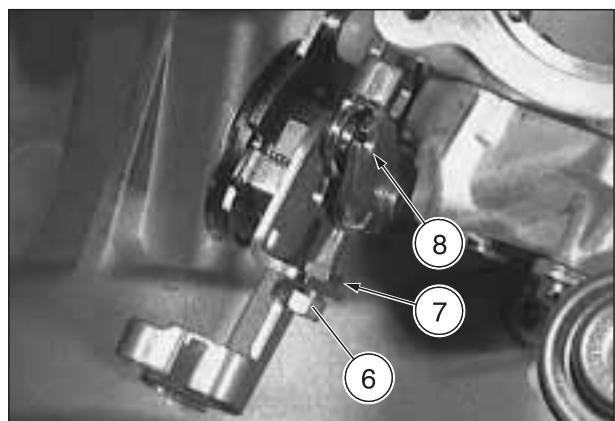
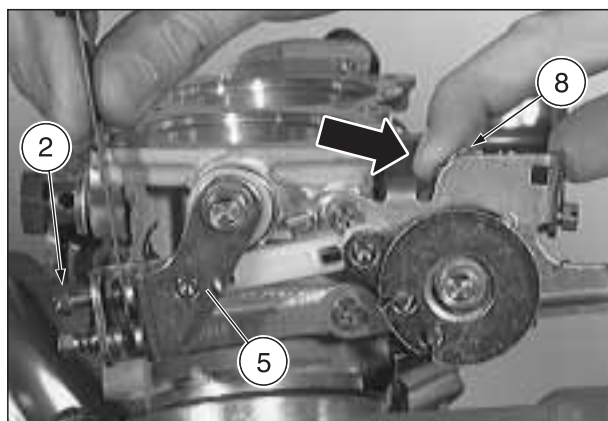
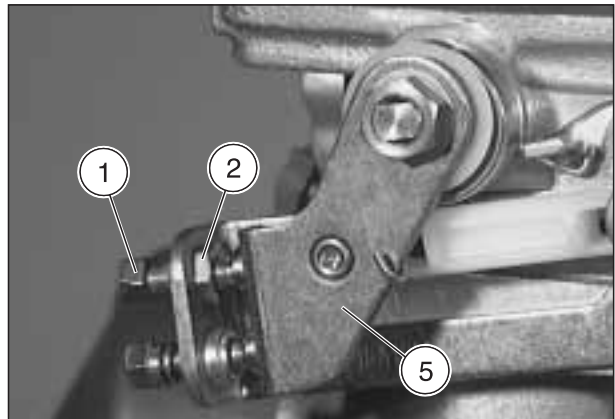
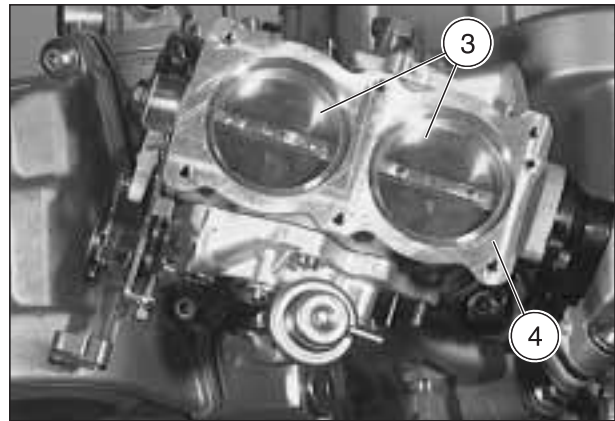
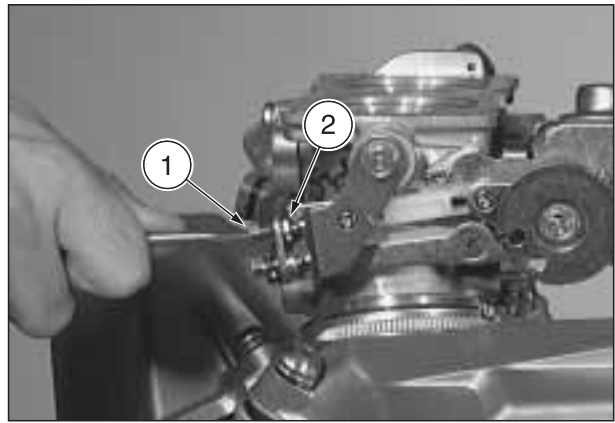

4.8.9 CHANGING AND ADJUSTING THE THROTTLE VALVE POTENTIOMETER

With the engine switched off:

- ◆ Lift the fuel tank, see 2.8 (LIFTING THE FUEL TANK).
- ◆ Disconnect the four-way connector (coloured black) (1).

⚠ CAUTION

The two screws M4x12 (2) that fasten the throttle valve potentiometer are painted and can be removed or loosened only in case of change or adjustment of the potentiometer itself.

NOTE In order to make it easier to unscrew the screws (2) secured using LOCTITE® 243, heat them first with a hot air blower.

- ◆ Unscrew and remove the screws (2).
- ◆ Remove the potentiometer (3).

⚠ CAUTION

Any adjustment of the position sensor must be performed with the valves closed, meaning the throttle valve control lever (4) must touch the adjusting screw (5).

- ◆ With the throttle valves in the closed position, place the potentiometer in its housing (3).

NOTE Apply LOCTITE® 243 on the thread of the screws (2).

- ◆ Screw the screws (2) on by hand so that they hold the potentiometer (3) in place but do not prevent it from rotating.
- ◆ Connect the four-way connector (coloured black) (1).
- ◆ Connect the two "TEST" terminals (6) with each other.
- ◆ Turn the ignition switch to position "O".
- ◆ Turn the potentiometer (3) until the display reads "0".
- ◆ Tighten the two screws (2), holding the potentiometer (3).

Driving torque of the throttle valve potentiometer screws (2): 1.6 Nm (0.16 kgm).

NOTE Verify the presence of the writing "0" on the display (7) and if the value displayed is different repeat the adjustment.

- ◆ Turn the ignition switch to position "⊗".
- ◆ Disconnect the two "TEST" terminals (6).
- ◆ Put back the fuel tank, see 2.8 (LIFTING THE FUEL TANK).

For further information, see 6.4.10 (CHECKING THE THROTTLE VALVE POTENTIOMETER).

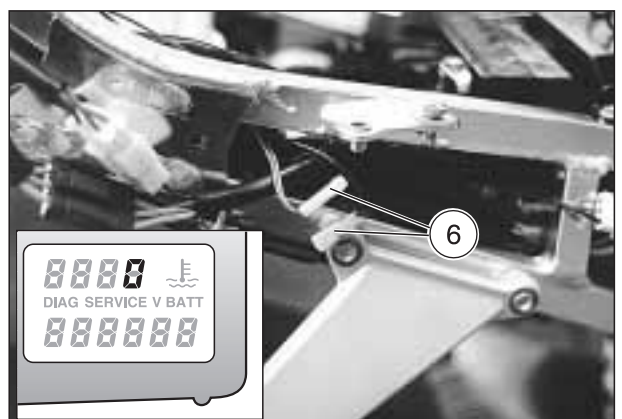
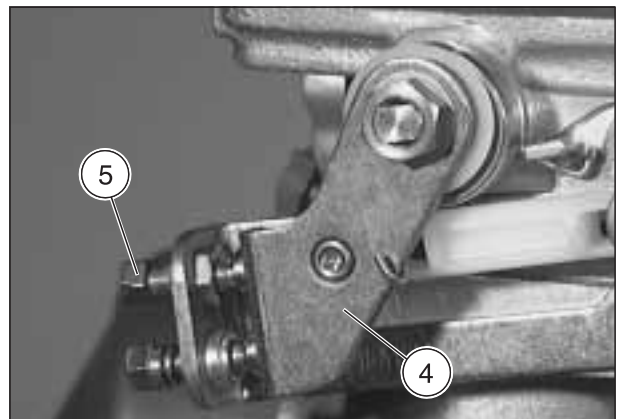
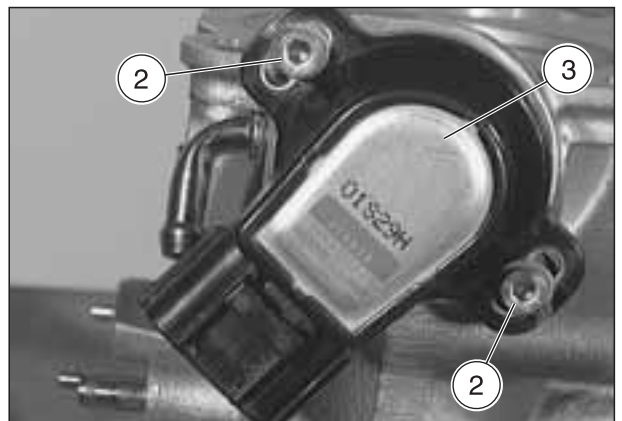
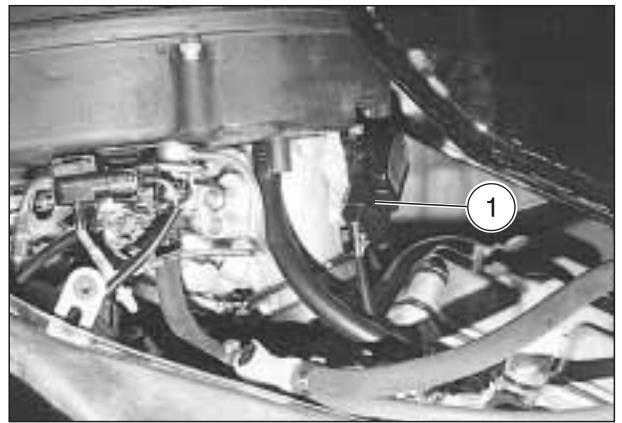

4.8.10 CYLINDER SYNCHRONIZATION

Carefully read 0.5.1 (PRECAUTIONS AND GENERAL INFORMATIONS) and 1.2.1 (FUEL).

Carburation, CO adjustment: Carburation, CO adjustment:

for the maintenance intervals, see 2.1.1 (REGULAR SERVICE INTERVALS CHART).

INTRODUCTION

The synchronization of the cylinders depends on the compliance with the following conditions:

- a) Engine idling speed:
 - 1250 ± 50 rpm ;
- b) CO values in the cylinders: (*1)
 - non-catalytic version (excluding USA) from 0.8% to 1.3% ;
 - catalytic version (excluding USA) from 1.5% to 2.0% ;
 - catalytic version USA from 1.5% to 2.0% ;
- c) Vacuum values in the cylinders: (*2)
 - 300 ± 30 mbar.

(*1) A difference is accepted for the CO values: of cylinder "1" (front) and of cylinder "2" (rear).

(*2) A difference is accepted for the vacuum values: of cylinder "1" (front) and of cylinder "2" (rear).

NOTE To obtain the synchronization of the cylinders, adjust the above mentioned values repeatedly, always following the given order.

NOTE The adjustment of one of the three values may cause the incorrect modification of the other two values, therefore after any adjustment it is advisable to check all the three values.

The CO value takes priority over the vacuum value.

- ◆ Check the engine number, see 1.1.2 (ENGINE NUMBER), and choose the suitable procedure according to the result of this check.

NOTE From engine # 686065.. To allow the check of the cylinder vacuum values, the throttle body is equipped with the special coupling (1) and therefore it is not necessary to replace the intake flange with the vacuumeter socket (2)

NOTE From engine # 686065. DO NOT carry out the operations marked with the symbol "✖".

- NOTE** Have the appropriate special tool **OPT** to hand:
- aprilia part# 8140267 (intake flange for vacuumeter) (2);
 - aprilia part# 8140256 (vacuumeter) (3).

- ◆ Lift the fuel tank, see 2.8 (LIFTING THE FUEL TANK).

Follow ►

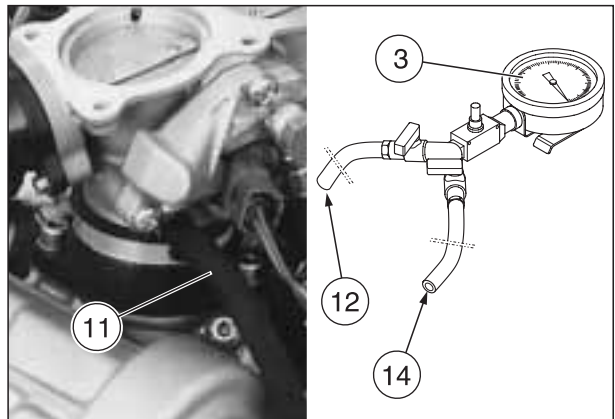
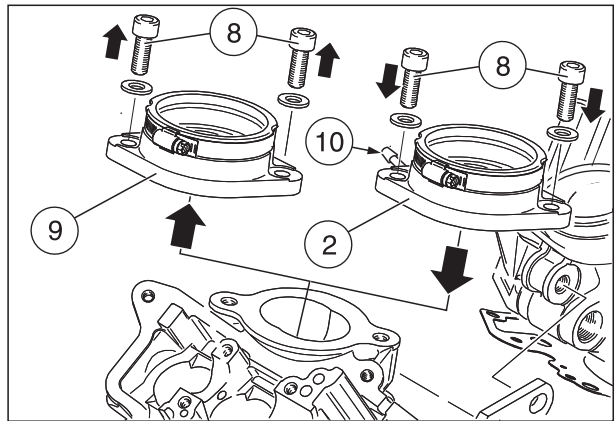

Follow ►

- ◆ ✖ Loosen the two clamps (4) (5).

⚠ CAUTION

✖ **Take extreme care when removing the throttle body (6) as it remains connected to cables and pipes.**

- ◆ ✖ Grip the throttle body firmly (6), complete with air filter casing (7), and shift it slightly one way and the other, lifting and sliding it off the intake flanges.
- ◆ ✖ Move the throttle body off to the left-hand side of the vehicle.
- ◆ ✖ Unscrew and remove the two screws (8) fastening the intake flange (9) to the front cylinder and recover the washers.
- ◆ ✖ Remove the intake flange (9) of cylinder "1" (front).
- ◆ ✖ Fit the vacuummeter intake flange (2) in place, and position it so that the connector (10) is on the right-hand side of the vehicle.
- ◆ ✖ Fit the two screws (8) back in place with their respective washers and tighten them.

Torque settings of screws (8): 19 Nm (1.9 kgm).

⚠ CAUTION

✖ **The throttle body (6) must be fitted perfectly on the intake flanges;**

The clamps (4) (5) must be properly tightened.

- ◆ ✖ Fit the throttle body (6) again, complete with air filter casing (7), to the two intake flanges.
- ◆ ✖ Tighten the two clamps (4) (5).
- ◆ Slide the pipe (11) off the vacuum connector.
- ◆ Hang the vacuummeter (3) on the handlebars.
- ◆ Insert the free end of the vacuummeter pipe (12) into the connector (13).
- ◆ ✖ Insert the free end of the vacuummeter pipe (14) into the connector (10) of the intake flange (2).
- ◆ **From engine # 686065.** Insert the free end of the vacuummeter pipe (14) into the connector (1) of the throttle body.

Follow ►

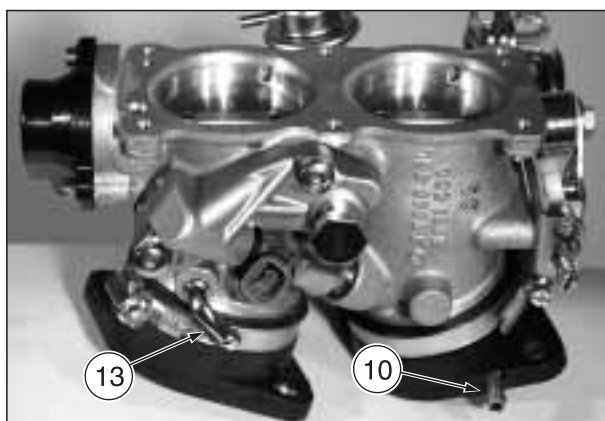
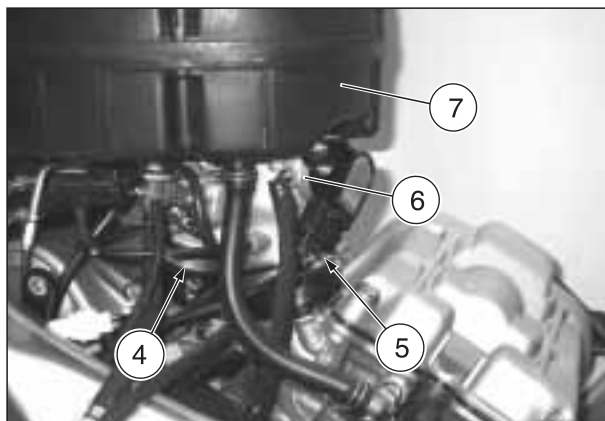

Follow ►

CAUTION

The cylinder synchronization must be carried out with the engine warmed up:

- coolant temperature 75 – 95 °C (167 – 203 °F);
- room temperature 20 – 30 °C (68 – 86 °F).

NOTE Have the appropriate special tools **OPT** to hand:
 - **aprilia** part# 8140196 [Plurigas (Italian)] (15) or **aprilia** part# 8140578 [Plurigas (English)] (15);
 - **aprilia** part# 8140202 (exhaust gas analysis probes) (16).

WARNING

Fuel vapours are noxious for your health. Before proceeding, make sure that the room in which you are working is properly ventilated. Do not inhale fuel vapours.

Avoid any contact of the fuel with the skin. Do not smoke and do not use naked flames. Do not dispose of fuel in the environment.

Plugs (17) (18) driving torque: 25 Nm (2.5 kgm).

- ◆ Loosen and remove the two front and rear exhaust pipe plugs (17) (18).

NOTE Upon reassembly, apply **aprilia** part# 8116043 (ANTI-SEIZE MOTAGEPASTE AS 1800 antiscuff paste) on the threaded of the plugs (17) (18).

- ◆ Connect the exhaust gas analysis probes (16) by proceeding as follows:
 - connect the two rigid pipes to the appropriate exhaust pipe outlets A) and (B);
 - connect the other pipe to the exhaust gas tester (15).
- ◆ Start the engine.
- ◆ Check the following on the revolution counter:
 - engine idling speed. For the value, see INTRODUCTION, point a).
- ◆ Check the following on the analyzer:
 - the CO values in the cylinders. For the values, see INTRODUCTION, point b).
 - the vacuum values in the cylinders. For the values, see INTRODUCTION - point c).

If the adjustment is necessary:

NOTE Proceed with the adjustment of the value that is not within the prescribed range, following the instructions given in the INTRODUCTION.

- ◆ For the engine idling speed, see 2.11.2 (IDLING ADJUSTMENT).

Follow ►

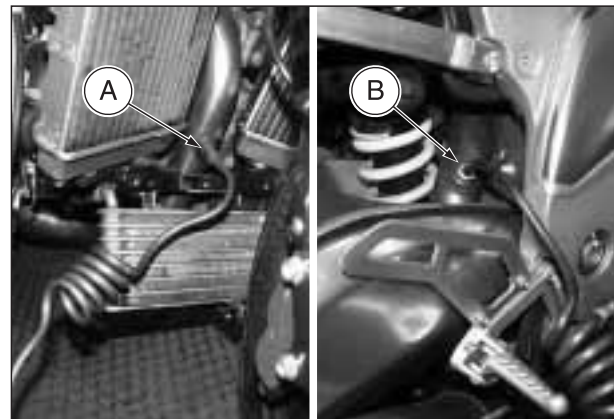
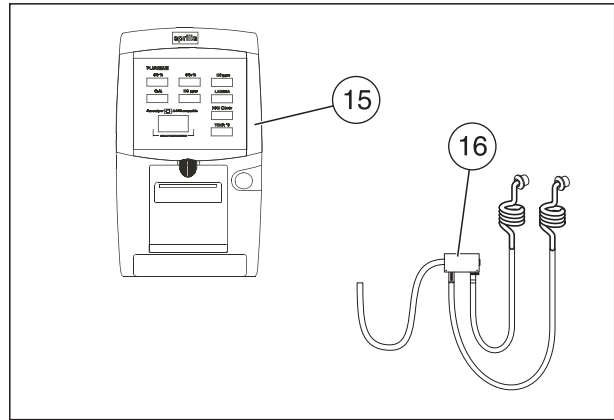

Follow ►

- ◆ Check the first five digits of the frame number and choose the suitable procedure according to the result of this check.

PROCEDURE FOR THE VEHICLES WHOSE FRAME BEARS THE ZD4ME CODE

- ◆ For the CO values in the cylinders, adjust:
 - the screw (19) for cylinder “1” (front);
 - the screw (20) for cylinder “2” (rear);
- ◆ For the vacuum values in the cylinders, adjust:
 - the screw (19) (of the throttle body) for cylinder “1” (front);
 - the screw (20) (of the throttle body) for cylinder “2” (rear);

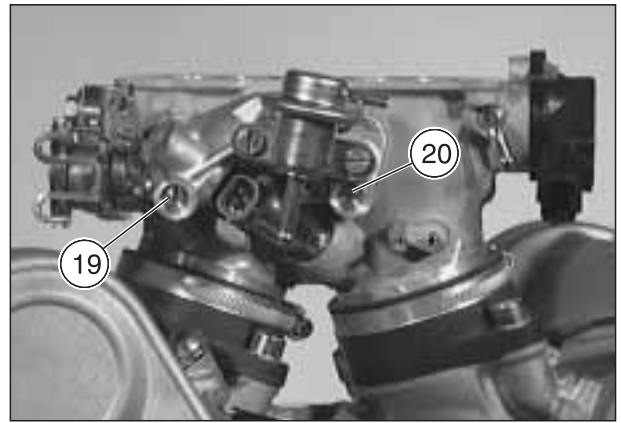

PROCEDURE FOR THE VEHICLES WHOSE FRAME BEARS THE ZD4RP CODE

- ◆ For the CO values in the cylinders, adjust:
 - the screw (21) (of the central unit) for cylinder “1” (front);
 - the screw (22) (of the central unit) for cylinder “2” (rear).
- ◆ For the vacuum values in the cylinders, adjust:
 - the screw (21) (of the central unit) for cylinder “1” (front);
 - the screw (22) (of the central unit) for cylinder “22” (rear).

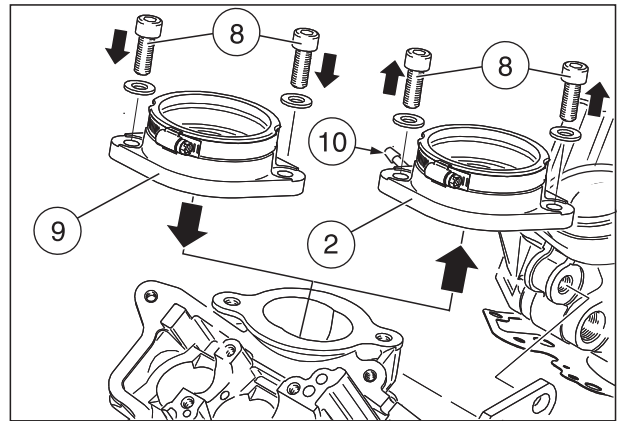

At the end of the cylinder synchronization check or adjustment:

- ◆ ✖ Remove the vacuum socket (2) and put back the intake flange (9).

⚠ CAUTION

- ✖ It is vital that the vacuum intake flange (2) be replaced with the original intake flange (9).

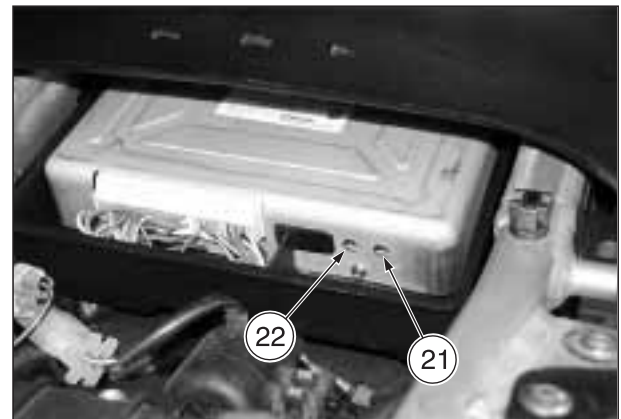

COOLING SYSTEM

5

COOLING SYSTEM

TABLE OF CONTENTS

5.1 DESCRIPTION 5-3-00

5.1.1 PATH WITH COOLANT TEMPERATURE BELOW 65 °C (149 °F) 5-4-00

5.1.2 PATH WITH COOLANT TEMPERATURE IN THE RANGE 65 °C (149 °F) TO 80 °C (176 °F) 5-5-00

5.1.3 PATH WITH COOLANT TEMPERATURE OVER 80 °C (176 °F) 5-6-00

5.2 REMOVING THE RADIATORS 5-7-00

5.3 REMOVING THE COOLING ELECTROFANS 5-8-00

5.4 REMOVING THE COOLANT THERMAL SWITCH 5-9-00

5.5 REMOVING THE COOLANT THERMISTORS 5-9-00

5.6 REMOVING THE THERMAL EXPANSION VALVE 5-10-00

5.6.1 CHECKING THE THERMAL EXPANSION VALVE 5-10-00

5.7 REMOVING THE FILLER NECK 5-11-00

5.8 REMOVING THE THREE-WAY MANIFOLD 5-12-00

5.9 REMOVING THE EXPANSION TANK 5-13-00

5.10 COOLANT PUMP 5-13-00

5

5.1 DESCRIPTION

The centrifugal pump (positioned inside the engine and driven by the latter) draws coolant and distributes it to the galleries in the cylinders and in the heads in order to cool the internal parts of the engine.

The path of the coolant on leaving the engine varies depending on the temperature of the actual coolant, and is illustrated below.

The coolant volume increase (caused by the temperature increase) is compensated for in the expansion tank.

To check and top up the coolant, refer to the “LOW” and “FULL” reference marks, see 2.15 (CHECKING AND TOPPING UP COOLANT).

For any information regarding the coolant, see 1.2.5 (COOLANT).

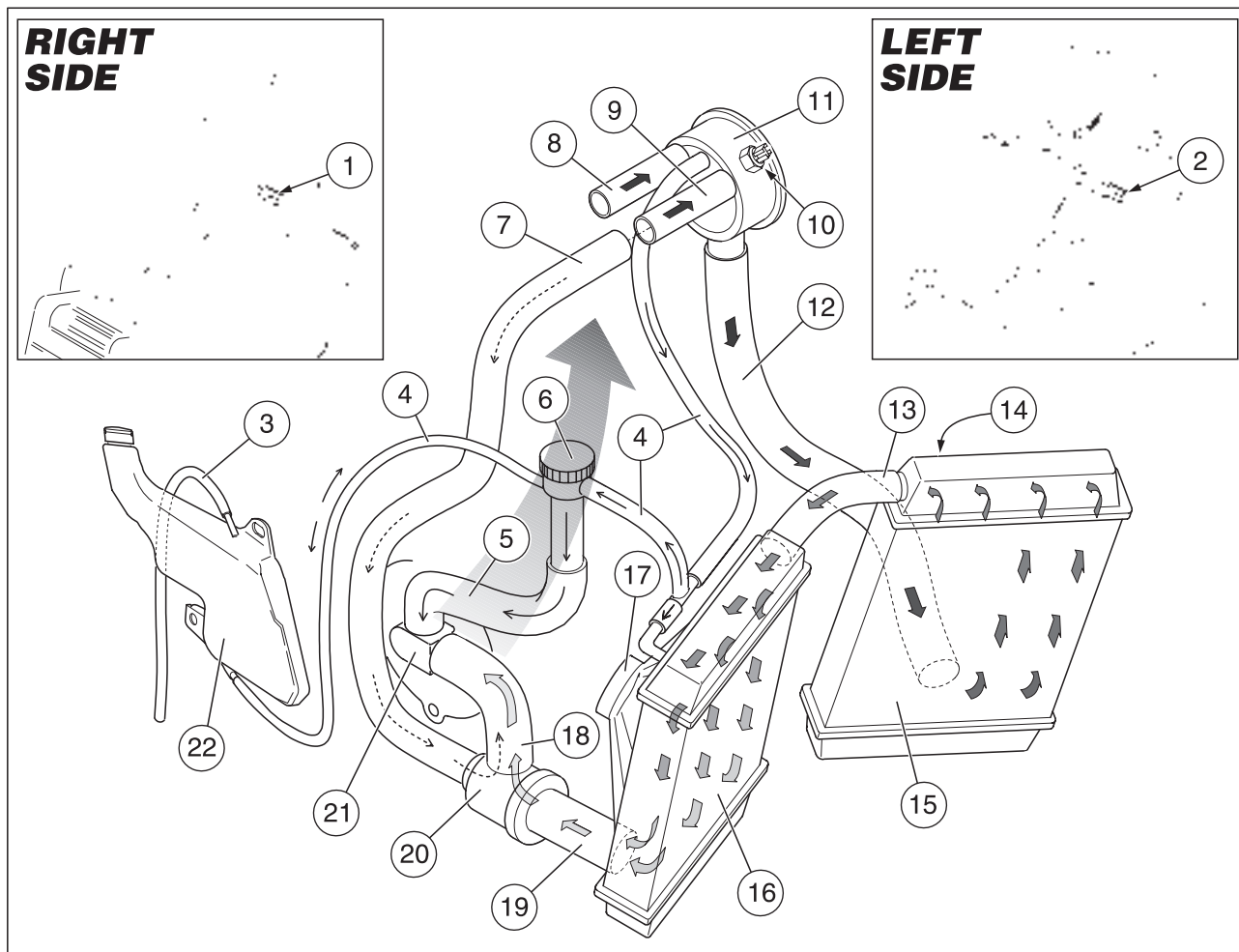

Key

- | | |
|---|--|
| <ul style="list-style-type: none"> 1) Front cylinder thermistor 2) Rear cylinder thermistor 3) Breather pipe 4) Coolant compensation pipes 5) Filler hose 6) Filler neck 7) Engine hose (right side) - thermal expansion valve 8) Rear cylinder hose - three-way manifold 9) Front cylinder hose - three-way manifold 10) Thermal switch 11) Three-way manifold 12) Three-way manifold hose - left radiator 13) Radiator link hose 14) Left radiator electrofan | <ul style="list-style-type: none"> 15) Left radiator (vertical flow) 16) Right radiator (vertical flow) 17) Right radiator electrofan 18) Thermal expansion valve hose - pump 19) Right radiator hose - thermal expansion valve 20) Three-way thermal expansion valve (type with heat-sensitive wax) 21) Centrifugal pump 22) Expansion tank |
|---|--|
- > = Direction of flow with thermal expansion valve open
 - - - - -> = Direction of flow with thermal expansion valve shut

5.1.1 PATH WITH COOLANT TEMPERATURE
BELOW 65 °C (149 °F)

From pump (1) "A" coolant inlet in engine (2) "B" temperature taken by thermistors (3) (4) and displayed on dashboard right display. "C" Coolant outlet from engine (right side) (5) "D" to thermal expansion valve (6) (completely closed) "E" and to pump (1).

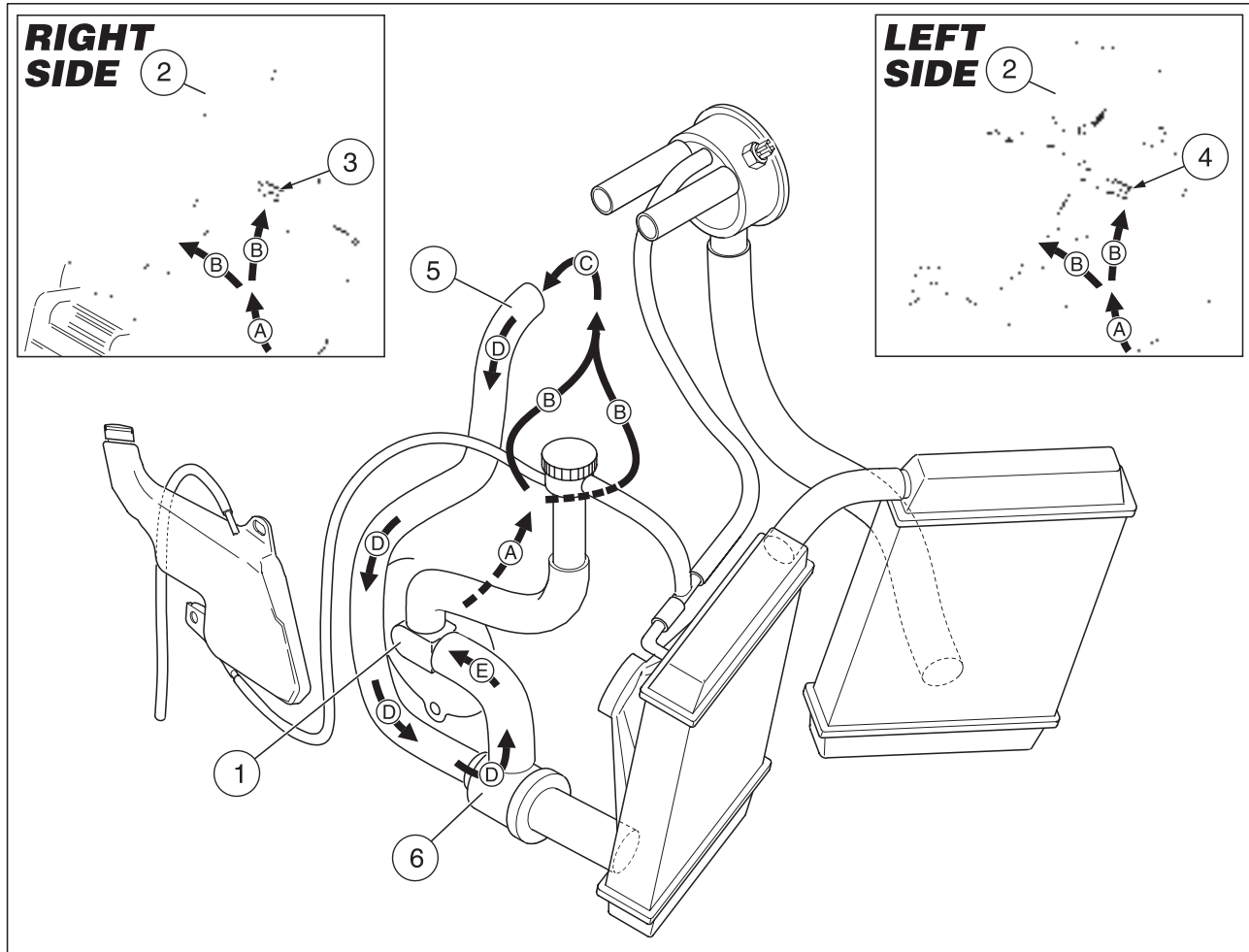

5.1.2 PATH WITH COOLANT TEMPERATURE IN THE RANGE 65 °C (149 °F) TO 80 °C (176 °F)

From pump (1) "A" coolant inlet in engine (2) "B" temperature taken by thermistors (3) (4) and displayed on dashboard right display. "C" Coolant outlet from the following at the same time:

- engine (right side) (5) "D" to thermal expansion valve (6) (partially open);
- engine (left side) (7)(8) "E" to three-way manifold (9) "F" to left radiator (10) "G" to right radiator (11) "H" to thermal expansion valve (6) (partially open).

From thermal expansion valve (partially open) "I" to pump (1).

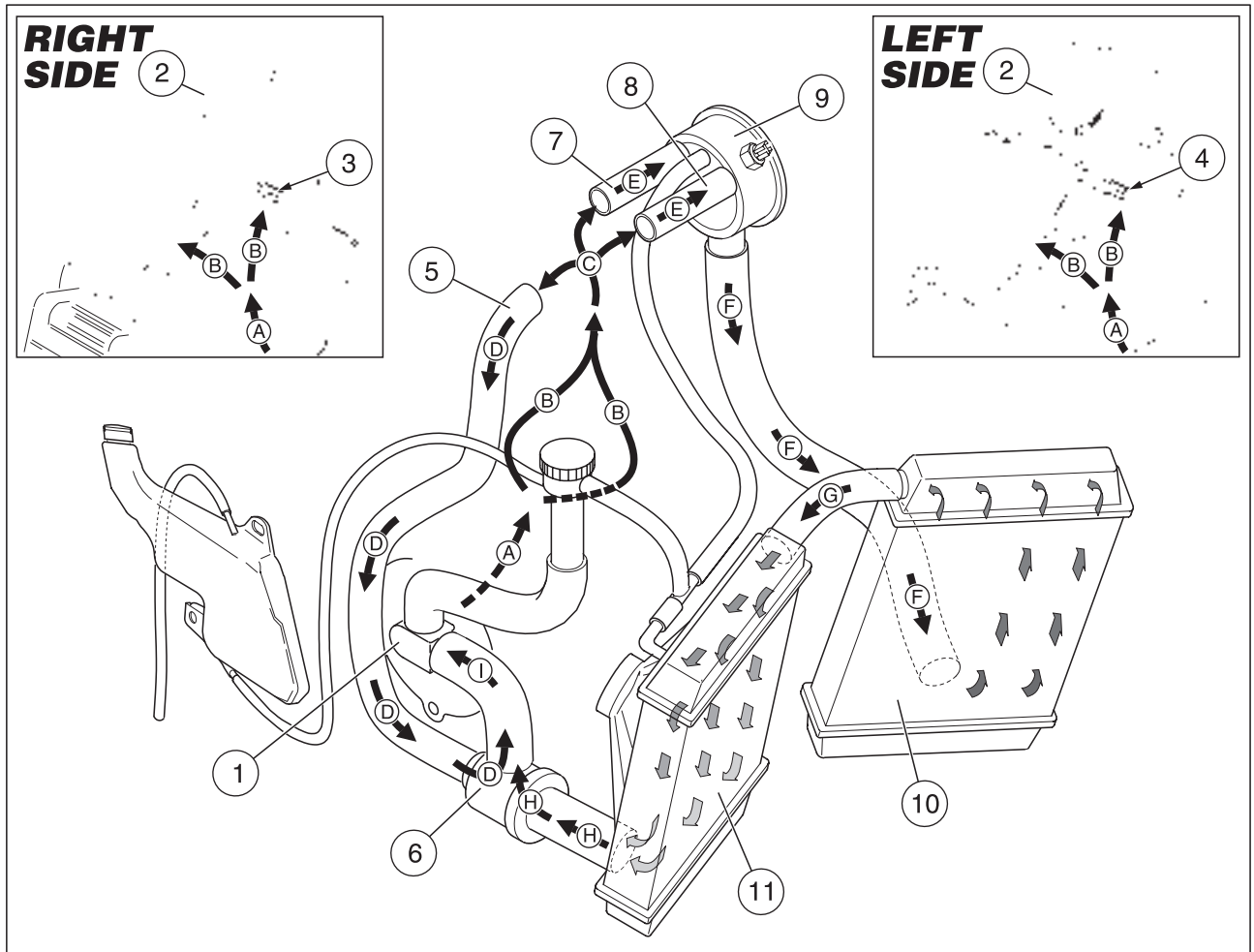

5.1.3 PATH WITH COOLANT TEMPERATURE OVER 80 °C (176 °F)

From pump (1) "A" coolant inlet in engine (2) "B" temperature taken by thermistors (3) (4) and displayed on dashboard right display. "C" Coolant outlet from engine (left side) (7) (8) "D" to three-way manifold (9)(*) "E" to left radiator (10) "F" to right radiator (11) "G" to thermal expansion valve (6) (completely open) "H" to pump (1).

(*) Temperature taken by the thermal switch (12):

- if the temperature exceeds 100°C (212 °F), it enables the operation of the electric fans (13);
- if the temperature lowers below 85°C (185 °F), it disables the operation of the electric fans (13).

CAUTION
 When the ignition switch is set to "⊗" the electrofans switch off regardless of the coolant temperature.

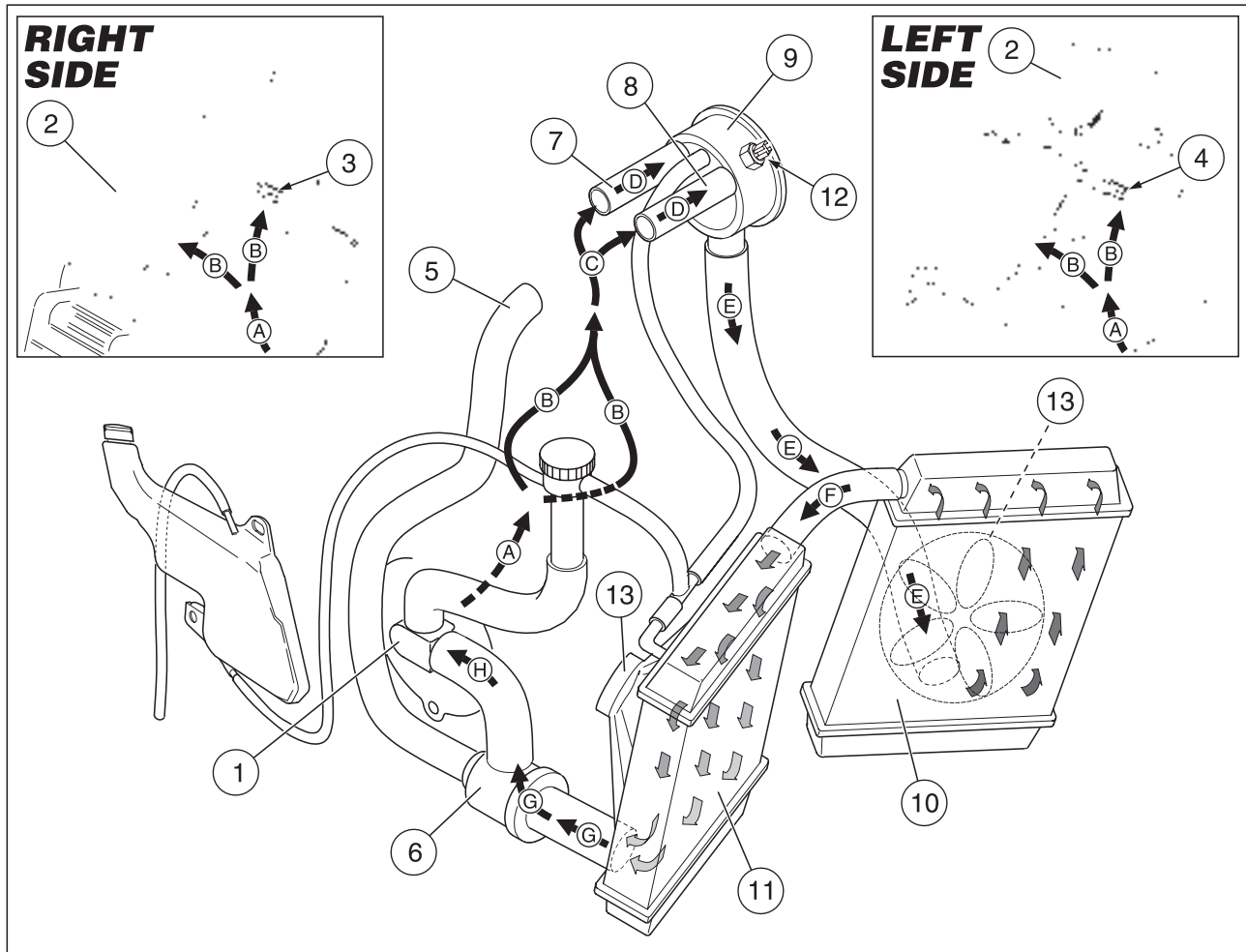

5.2 REMOVING THE RADIATORS

Carefully read 0.5.1 (PRECAUTIONS AND GENERAL INFORMATIONS) and 1.2.5 (COOLANT).

NOTE The following procedure refers to a single radiator, though it is applicable to both.

- ◆ Turn the ignition switch to position "OFF".
- ◆ Drain the cooling circuit completely, see 2.16 (CHANGING THE COOLANT).
- ◆ Disconnect the electric connector (1).

⚠ CAUTION

Upon reassembly, make sure that the electric connector (1) is correctly coupled.

- ◆ Remove the radiator spoiler, see 7.1.35 (REMOVING THE RADIATOR SPOILER).
- ◆ Loosen and move the clamp (2).
- ◆ Pull the coupling (3) off the radiator (4).
- ◆ Loosen and move the clamp (5).
- ◆ Pull the coupling (6) off the radiator (4).

NOTE Have the appropriate special tool **OPT** to hand:
– aprilia part# 0277295 (hose clamp installation pliers).

⚠ CAUTION

Upon installation, replace the hose clamp that has been removed with a new one having the same dimensions, see 0.4.2 (SPARE PARTS CATALOGUES).

Do not attempt to reinstall the removed hose clamp, since it is unusable.

Do not replace the removed hose clamp with a screw clamp or with other types of clamp.

- ◆ Release the hose clamp (7).
- ◆ Pull the pipe (8) off the radiator (4).
- ◆ Unscrew and remove the screw (9), retrieving the bush and the rubber element (10) if necessary.

NOTE If the rubber element (10) is damaged, replace it.

⚠ CAUTION

Proceed with care.

Do not damage the radiator fins.

- ◆ Tilt the radiator (4) slightly forwards and at the same time lift it, sliding the two lower anchorage pins (12) (13) from their slot on the radiator mount (11).
- ◆ Remove the radiator (4) complete with the electrofan (14).

⚠ CAUTION

Plug the coupling openings, in such a way as to prevent any foreign matters from getting in.

NOTE If the rubber elements (15) are damaged, replace them.

If necessary, proceed as follows:

- ◆ Remove the cooling electrofan, see 5.3 (REMOVING THE COOLING ELECTROFANS).

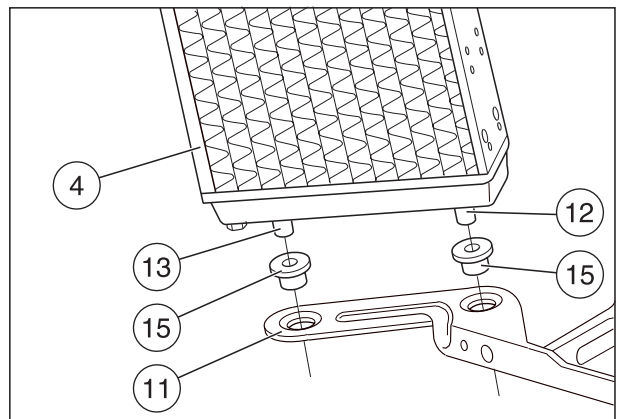
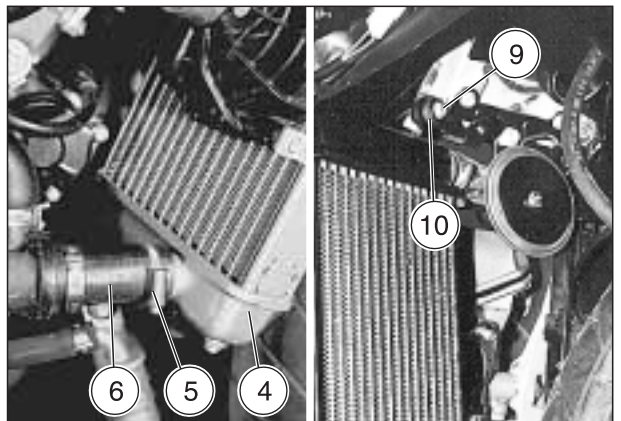
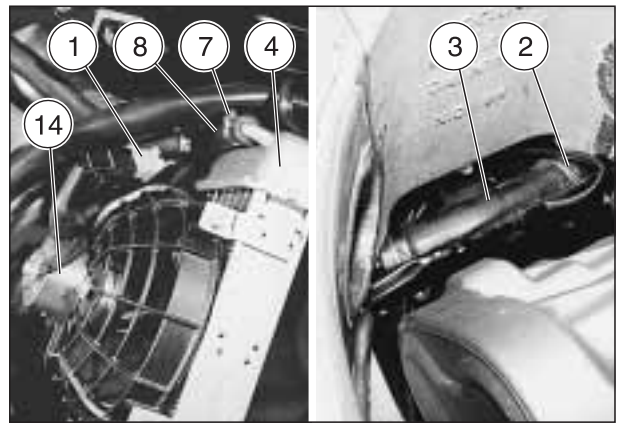

⚠ CAUTION

Foreign bodies, filth, etc. sticking to the radiator fins must be removed by means of a jet of compressed air.

Any bent fins are to be straightened using a small flat-tip screwdriver.

If the couplings (3) (6) feature cuts and/or cracks, they must be replaced.

Before reassembly, thoroughly wash the inside of the radiator with clean water only.

NOTE Where necessary, remove the other radiator.

5.3 REMOVING THE COOLING ELECTROFANS

Carefully read 0.5.1 (PRECAUTIONS AND GENERAL INFORMATIONS).

NOTE The following procedure refers to a single electrofan, though it is applicable to both.

- ◆ Turn the ignition switch to position "OFF".
- ◆ Remove the relevant side fairing, see 7.1.28 (REMOVING THE SIDE FAIRINGS).
- ◆ Disconnect the electric connector (1).

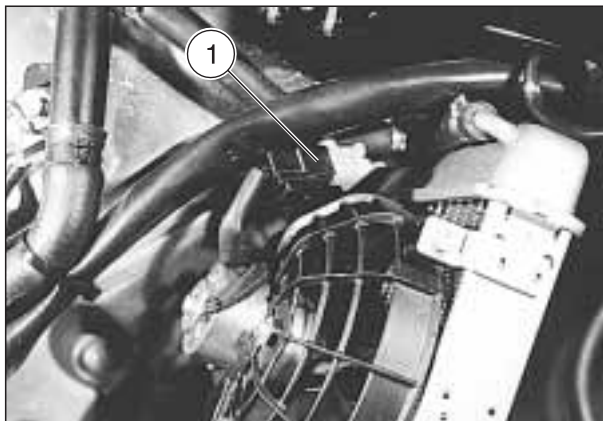

CAUTION
Upon reassembly, make sure that the electric connector (1) is correctly coupled.

- ◆ Unscrew and remove the two screws (2).

Screws (2) driving torque: 6 Nm (0.6 kgm).

- ◆ Retrieve the two nuts (3).
- ◆ Tilt the whole electrofan (4) slightly forwards, at the same time moving it outwards, pulling the internal anchorage pin out of its slot on the radiator (5).
- ◆ Remove the electrofan (4).

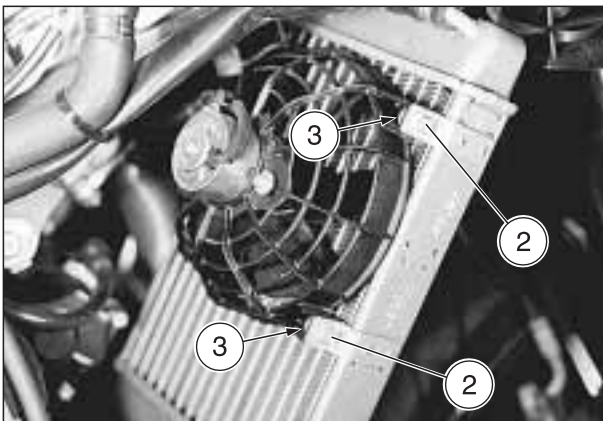

NOTE If the rubber element (6) is damaged, replace it.

If necessary, proceed as follows:

- ◆ Unscrew and remove the three screws (7) and retrieve the washers.

Screws (7) driving torque: 2 Nm (0.2 kgm).

- ◆ Slide out the grating (8) protecting the electrofan motor (9).

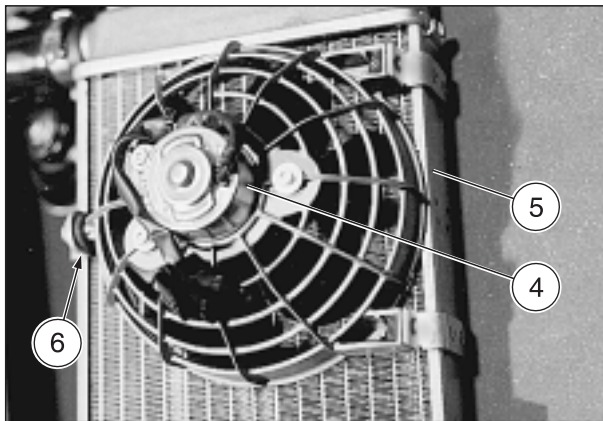

NOTE Where necessary, remove the other electrofan. See 6.9 (COOLING ELECTROFAN) for further details.

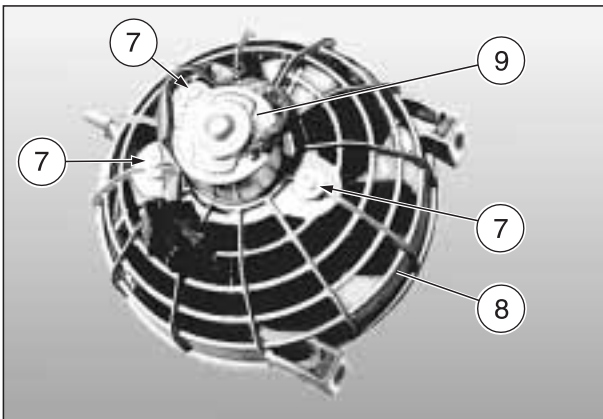

5.4 REMOVING THE COOLANT THERMAL SWITCH

Carefully read 0.5.1 (PRECAUTIONS AND GENERAL INFORMATIONS) and 1.2.5 (COOLANT).

- ◆ Turn the ignition switch to position "⊗".
- ◆ Remove the left fairing, see 7.1.28 (REMOVING THE SIDE FAIRINGS).
- ◆ Disconnect the electric connectors (1) (2) from the thermal switch (3).

⚠ CAUTION

When reassembling, make sure the electric connectors (1–2) are plugged in properly.

- ◆ Prepare a new thermal switch and apply LOCTITE® 572 on its thread.
- ◆ Unscrew and remove the thermal switch (3) and retrieve the gasket.
- ◆ Insert the gasket on the new thermal switch.
- ◆ Screw the thermal switch (3) on by hand before tightening it.

Thermal switch (3) driving torque: 30 Nm (3.0 kgm).

- ◆ If any coolant spilled during removal, once the operation is complete, top up the coolant, see 2.15 (CHECKING AND TOPPING UP COOLANT).

NOTE See 6.9.3 (CHECKING THE THERMAL SWITCH OPERATION) for further details on the thermal switch.

⚠ CAUTION

Plug the hole on the three-way manifold so as to prevent any foreign bodies from falling in.

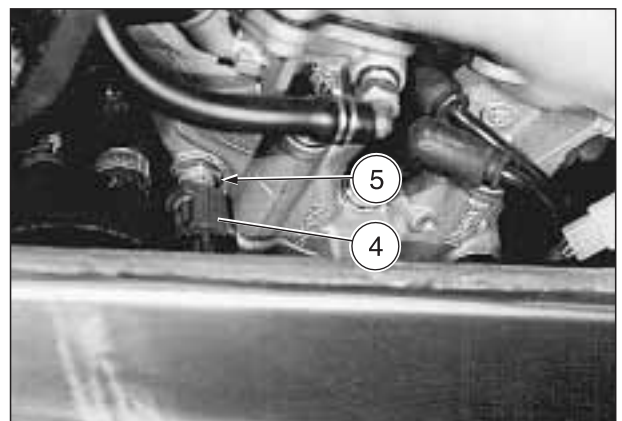
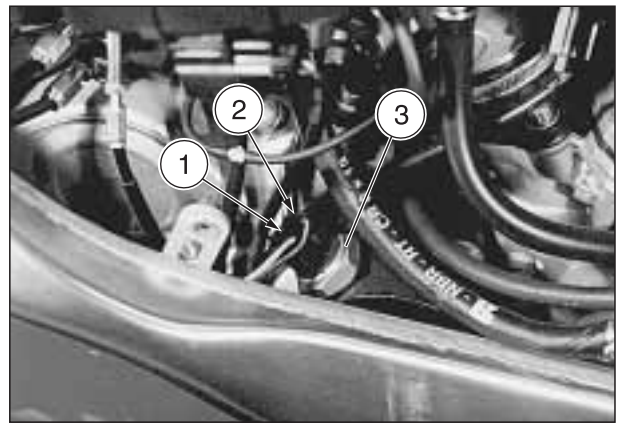

5.5 REMOVING THE COOLANT THERMISTORS

Carefully read 0.5.1 (PRECAUTIONS AND GENERAL INFORMATIONS) and 1.2.5 (COOLANT).

NOTE The following procedure refers to a single thermistor, though it is applicable to both.

- ◆ Lift the fuel tank, see 2.8 (LIFTING THE FUEL TANK).
- ◆ Disconnect the electric connector (4).

⚠ CAUTION

Upon reassembly, make sure that the electric connector (4) is correctly coupled.

- ◆ Prepare a new thermistor and apply LOCTITE® 574 on its thread.
- ◆ Unscrew and remove the thermistor (5).
- ◆ Screw the thermistor (5) on by hand before tightening it.

Thermistor (5) driving torque: 30 Nm (3.0 kgm).

- ◆ If any coolant spilled during removal, once the operation is complete, top up the coolant, see 2.15 (CHECKING AND TOPPING UP COOLANT).

NOTE Where necessary, remove the other thermistor. See 6.4.8 (CHECKING THE COOLANT THERMISTOR OPERATION) for further details on the thermistors.

5.6 REMOVING THE THERMAL EXPANSION VALVE

Carefully read 0.5.1 (PRECAUTIONS AND GENERAL INFORMATIONS) and 1.2.5 (COOLANT).

- ◆ Drain the cooling circuit completely, see 2.16 (CHANGING THE COOLANT).

NOTE Have the appropriate special tool **OPT** to hand:
 – **aprilia** part# 0277295 (hose clamp installation pliers).

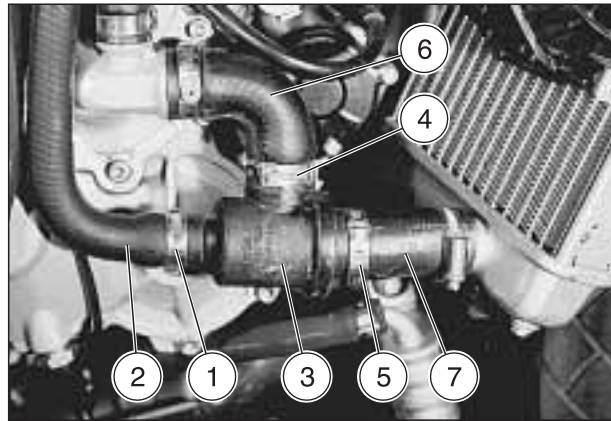

CAUTION

Upon installation, replace the hose clamp that has been removed with a new one having the same dimensions, see 0.4.2 (SPARE PARTS CATALOGUES).

Do not attempt to reinstall the removed hose clamp, since it is unusable.

Do not replace the removed hose clamp with a screw clamp or with other types of clamp.

- ◆ Release the hose clamp (1).
- ◆ Pull the pipe (2) off the thermal expansion valve (3).

Clamps driving torque (4) (5): 7 Nm (0.7 kgm).

- ◆ Loosen the clamps (4) (5).
- ◆ Grip the thermal expansion valve (3) and pull it free of the two couplings (6) (7) one small step at a time.

CAUTION

Plug the coupling openings, in such a way as to prevent any foreign matters from getting in.

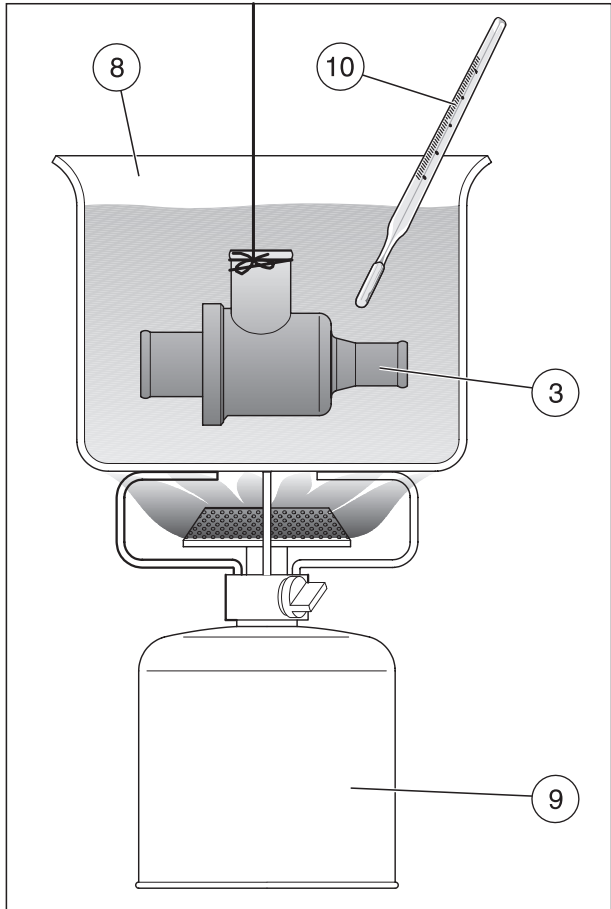

5.6.1 CHECKING THE THERMAL EXPANSION VALVE

Carefully read 0.5.1 (PRECAUTIONS AND GENERAL INFORMATIONS) and 1.2.5 (COOLANT).

- ◆ Remove the thermal expansion valve, see 5.6 (REMOVING THE THERMAL EXPANSION VALVE).
- ◆ Check the heat-sensitive wax for signs of cracking or excessive wear: in this case, replace the whole valve (3).

Check the valve (3) is working properly as follows:

- ◆ Tie a piece of string around the valve (3).
- ◆ Place a container (8) holding coolant on a burner (9).
- ◆ Immerse the valve (3) in the container.

NOTE The valve (3) must be fully submersed without allowing it to touch the walls or bottom of the container (8).

- ◆ Secure the string so that the valve (3) remains in place.
- ◆ Heat the coolant, using a thermometer (10) with a 0 – 150 °C (32 – 302 °F) range to check the rise in temperature.

Follow ►

Follow ►

- ◆ Take note of the temperature reading when the valve (3) starts to open.

Valve (3) opening temperature:
 $65 \pm 2 \text{ }^\circ\text{C}$ ($149 \pm 3.6 \text{ }^\circ\text{F}$).

- ◆ Continue heating the coolant.
- ◆ When the temperature of the coolant reaches $80 \text{ }^\circ\text{C}$ ($176 \text{ }^\circ\text{F}$), the valve (3) should have opened by at least 7 mm (39 mm measured from the edge).

Valve (3) opening: $\geq 7 \text{ mm}$ at $80 \text{ }^\circ\text{C}$ ($176 \text{ }^\circ\text{F}$).

NOTE If the valve does not meet both conditions (initial opening temperature and maximum opening), it must be replaced.

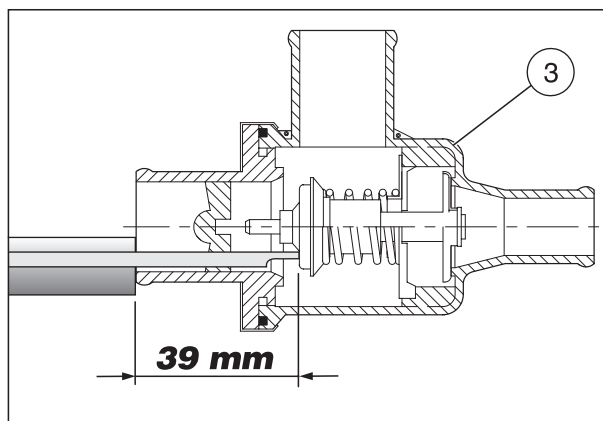

5.7 REMOVING THE FILLER NECK

Carefully read 0.5.1 (PRECAUTIONS AND GENERAL INFORMATIONS) and 1.2.5 (COOLANT).

- ◆ Drain the cooling circuit completely, see 2.16 (CHANGING THE COOLANT).

NOTE Have the appropriate special tool **OPT** to hand:
 – aprilia part# 0277295 (hose clamp installation pliers).

⚠ CAUTION

Upon installation, replace the hose clamp that has been removed with a new one having the same dimensions, see 0.4.2 (SPARE PARTS CATALOGUES).

Do not attempt to reinstall the removed hose clamp, since it is unusable.

Do not replace the removed hose clamp with a screw clamp or with other types of clamp.

- ◆ Release the hose clamp (1).
- ◆ Release the hose clamp (2).
- ◆ Pull the pipe (3) off the neck (4).
- ◆ Pull the coupling (5) off the neck (4).

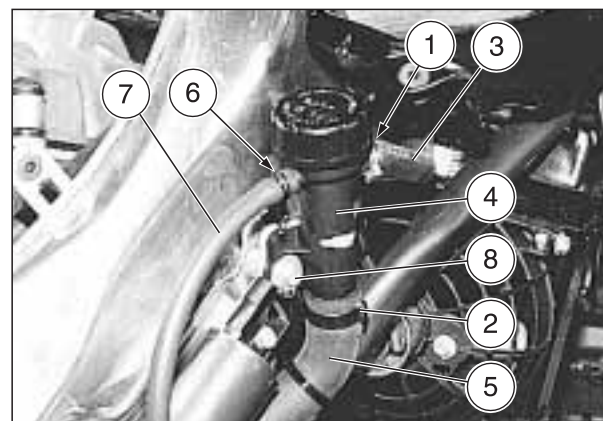

⚠ CAUTION

Plug the coupling openings, in such a way as to prevent any foreign matters from getting in.

- ◆ Move the pipe clamp (6).
- ◆ Pull the pipe (7) off the neck (4).
- ◆ Unscrew and remove the screw (8) and take the bushing.
- ◆ Remove the filler neck (4).

5.8 REMOVING THE THREE-WAY MANIFOLD

Carefully read 0.5.1 (PRECAUTIONS AND GENERAL INFORMATIONS) and 1.2.5 (COOLANT).

- ◆ Turn the ignition switch to position "⊗".
- ◆ Lift the fuel tank, see 2.8 (LIFTING THE FUEL TANK).
- ◆ Remove the engine oil tank, see 7.1.51 (REMOVING THE ENGINE OIL TANK).
- ◆ Drain the cooling circuit completely, see 2.16 (CHANGING THE COOLANT).
- ◆ Disconnect the electric connectors (1) (2) from the thermal switch (3).

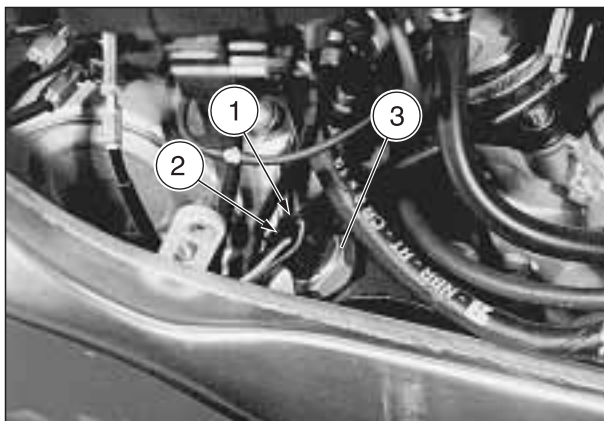

⚠ CAUTION

When reassembling, make sure the electric connectors (1) (2) are plugged in properly.

NOTE Have the appropriate special tool **OPT** to hand:
 – aprilia part# 0277295 (hose clamp installation pliers).

⚠ CAUTION

Upon installation, replace the hose clamp that has been removed with a new one having the same dimensions, see 0.4.2 (SPARE PARTS CATALOGUES).

Do not attempt to reinstall the removed hose clamp, since it is unusable.

Do not replace the removed hose clamp with a screw clamp or with other types of clamp.

- ◆ Release the hose clamp (4).
- ◆ Release the hose clamp (5).
- ◆ Release the hose clamp (6).
- ◆ Pull the three pipes (7) (8) (9) off the manifold (10).

Clamp driving torque (11): 3 Nm (0.3 kgm).

- ◆ Loosen the pipe clamp (11) and move it downwards.
- ◆ Grip the manifold (10) and slide it up off the coupling (12) one small step at a time.

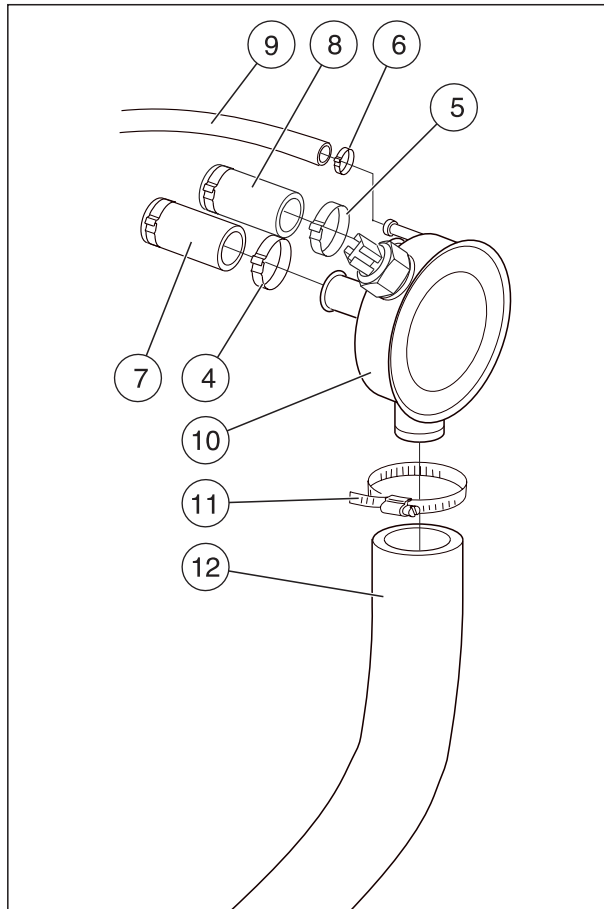

⚠ CAUTION

Plug the coupling openings, in such a way as to prevent any foreign matters from getting in.

If necessary, proceed as follows:

- ◆ Unscrew and remove the thermal switch (3) and retrieve the gasket.

NOTE When reassembling, apply LOCTITE® 572 on the thread of the thermal switch.

Thermal switch (3) driving torque: 30 Nm (3.0 kgm).

5.9 REMOVING THE EXPANSION TANK

Carefully read 0.5.1 (PRECAUTIONS AND GENERAL INFORMATIONS) and 1.2.5 (COOLANT).

- ◆ Remove the right fairing, see 7.1.28 (REMOVING THE SIDE FAIRINGS).
- ◆ Move the pipe clamp (1).
- ◆ Pull the pipe (2) off the filler neck (3).
- ◆ Bend the pipe (2) back on itself and secure it in place on the top of the expansion tank with adhesive tape.
- ◆ Unscrew and remove the fastening screw (4), keeping the rear brake fluid tank (5) in place.
- ◆ Move the rear brake fluid tank (5) and secure it in place with adhesive tape.
- ◆ Unscrew and remove the two fastening screws (6–7) and retrieve the two bushes.
- ◆ Remove the expansion tank (8), keeping it the right way up.
- ◆ If the inner and outer foam edging is damaged, replace it.

⚠ WARNING

The coolant is noxious.

Put the expansion tank (8) in a safe place.

KEEP AWAY FROM CHILDREN.

5.10 COOLANT PUMP

For further information on the coolant pump, refer to the engine service and repair manual, see 0.4.1 (ENGINE SERVICE AND REPAIR MANUALS).

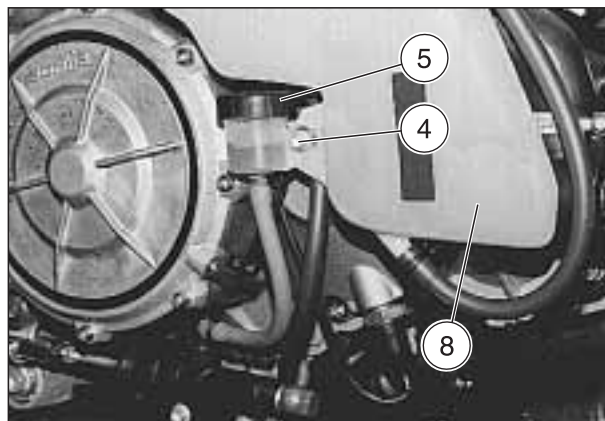
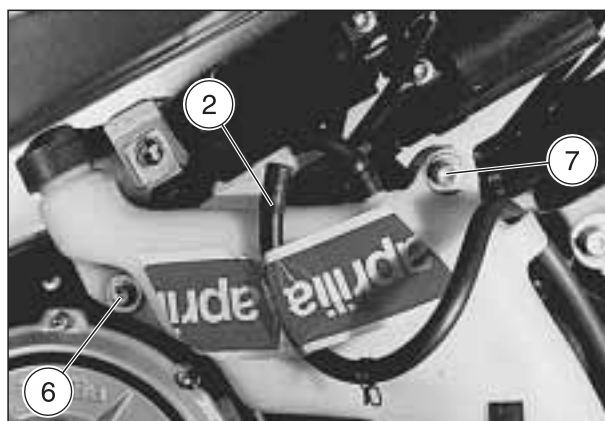
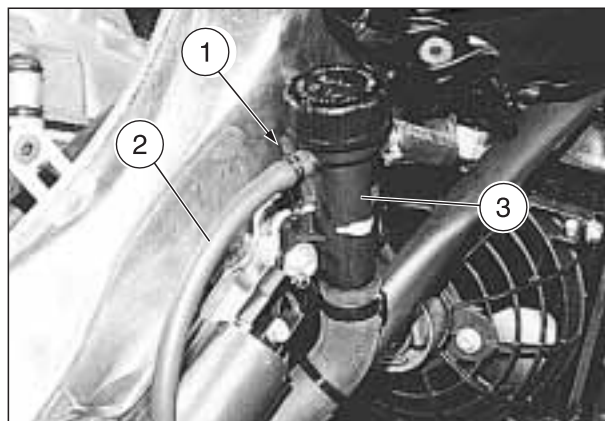

NOTES

THIS PAGE HAS BEEN INTENTIONALLY LEFT EMPTY

ELECTRIC SYSTEM

6

ELECTRIC SYSTEM

TABLE OF CONTENTS

6.1 INTRODUCTION	6-3-00
6.1.1 CABLE COLOURS	6-3-00
6.1.2 ELECTRICAL CONNECTORS	6-3-00
6.2 ELECTRIC COMPONENTS LAYOUT ...	6-4-00
6.3 CHECKING THE RECHARGING SYSTEM	6-6-00
6.3.1 CHECKING THE RECHARGING VOLTAGE	6-6-00
6.3.2 CHECKING THE ALTERNATOR LOADLESS OPERATION	6-6-00
6.3.3 CHECKING THE ALTERNATOR CONTINUITY	6-7-00
6.3.4 CHECKING THE VOLTAGE REGULATOR	6-7-00
6.4 IGNITION SYSTEM	6-8-00
6.4.1 WIRING DIAGRAM	6-8-00
6.4.2 TROUBLESHOOTING (IF THE ENGINE DOES NOT START)	6-9-00
6.4.3 ELIMINATING ELECTRONIC SYSTEM FAULTS ACCORDING TO THE INFORMATION SENT UP ON THE DISPLAY	6-11-00
6.4.4 CHECKING THE IGNITION COILS	6-12-00
6.4.5 CHECKING THE PICK-UP	6-12-00
6.4.6 CHECKING THE CAMSHAFT POSITION SENSOR	6-13-00
6.4.7 CHECKING THE FALL SENSOR	6-13-00
6.4.8 CHECKING THE COOLANT THERMISTOR OPERATION	6-14-00
6.4.9 CHECKING THE AIR THERMISTOR OPERATION	6-15-00
6.4.10 CHECKING THE THROTTLE VALVE POTENTIOMETER	6-16-00
6.4.11 CHECKING THE INTAKE PRESSURE SENSOR	6-17-00
6.4.12 CHECKING THE INJECTORS	6-18-00
6.5 FUEL PUMP SYSTEM	6-19-00
6.5.1 WIRING DIAGRAM	6-19-00
6.5.2 CHECKING THE FUEL PUMP	6-20-00
6.5.3 CHECKING THE FUEL PUMP RELAY	6-21-00
6.5.4 CHECKING THE ENGINE SHUTOFF RELAY	6-21-00
6.6 IGNITION SAFETY SYSTEM	6-22-00
6.6.1 WIRING DIAGRAM	6-22-00
6.6.2 STARTING SAFETY OPERATING LOGIC	6-23-00
6.6.3 CHECKING THE STARTING RELAY ...	6-23-00
6.6.4 CHECKING THE SIDE STAND AND THE SAFETY SWITCH	6-24-00
6.6.5 CHECKING THE DIODE MODULE	6-24-00
6.7 SWITCHES	6-25-00
6.7.1 SWITCH SET ON RIGHT HANDLEBAR	6-25-00
6.7.2 SWITCH SET ON LEFT HANDLEBAR ..	6-26-00
6.7.3 SINGLE SWITCHES	6-27-00
6.8 LIGHT SYSTEM	6-28-00
6.8.1 WIRING DIAGRAM	6-28-00
6.8.2 CHECKING THE LIGHTS RELAY	6-29-00
6.8.3 CHECKING THE LIGHTS / LAP DIODE (multifunction)	6-29-00
6.9 COOLING ELECTROFAN	6-30-00
6.9.1 WIRING DIAGRAM	6-30-00
6.9.2 CHECKING THE ELECTROFAN OPERATION	6-31-00
6.9.3 CHECKING THE THERMAL SWITCH OPERATION	6-32-00
6.9.4 CHECKING THE ELECTROFAN RELAY	6-32-00
6.10 INDICATORS ON THE DASHBOARD	6-33-00
6.10.1 WIRING DIAGRAM	6-33-00
6.10.2 LOW FUEL WARNING LIGHT	6-34-00
6.10.3 COOLANT TEMPERATURE DISPLAY	6-35-00
6.10.4 ENGINE OIL PRESSURE SENSOR	6-35-00
6.10.5 SPEEDOMETER	6-36-00
6.10.6 REVOLUTION COUNTER	6-37-00
6.11 BATTERY	6-38-00
6.11.1 ACTIVATING THE BATTERY	6-38-00
6.11.2 BATTERY MAINTENANCE	6-39-00
6.11.3 CHECKING THE BATTERY	6-39-00
6.11.4 RETURN UNDER GUARANTEE BATTERY	6-39-00
6.12 CHANGING THE BULBS	6-40-00
6.12.1 CHANGING THE HEADLIGHT BULBS	6-40-00
6.12.2 CHANGING THE FRONT AND REAR DIRECTION INDICATOR BULBS	6-43-00
6.12.3 CHANGING THE REAR LIGHT BULB	6-43-00
6.12.4 CHANGING THE DASHBOARD BULBS / LIGHTS	6-44-00
6.13 ADJUSTING THE VERTICAL HEADLIGHT BEAM	6-45-00
6.14 ADJUSTING THE HORIZONTAL HEADLIGHT BEAM ^{USA}	6-45-00
6.15 CHANGING THE FUSES	6-46-00
6.16 CHECKING THE SWITCHES	6-47-00
6.17 CONNECTIONS TO THE ENGINE CONTROL UNIT	6-48-00
6.18 WIRING DIAGRAM - RSV mille	6-50-00
6.19 WIRING DIAGRAM - RSV mille ^{ASD} ..	6-52-00

6.1 INTRODUCTION

The following key will be useful in consulting this section.

NOTE The numbering to be found on the specific wiring diagrams corresponds to that on the general wiring diagram.



6.1.1 CABLE COLOURS

Ar	orange
Az	light blue
B	blue
Bi	white
G	yellow
Gr	grey
M	brown
N	black
R	red
Ro	pink
V	green
Vi	violet

6.1.2 ELECTRICAL CONNECTORS

The disconnection of two electrical connectors must be carried out by proceeding as follows:

- ◆ Press the appropriate safety couplings, if provided.

⚠ CAUTION

Do not pull the cables to disconnect the two connectors.

- ◆ Grasp the two connectors and disconnect them by pulling in opposite directions.
- ◆ If dirt, rust, dampness, etc. can be noticed, carefully clean the inside of the connector by means of a pressurized air jet.
- ◆ Make sure that the cables are correctly crimped to the terminals positioned inside the connectors.

NOTE The two connectors have one insertion direction only, therefore it is important to couple them in the correct direction.

- ◆ Insert the two connectors, making sure that the coupling direction is correct (if the appropriate safety couplings are provided, the typical “click” sound will be heard).

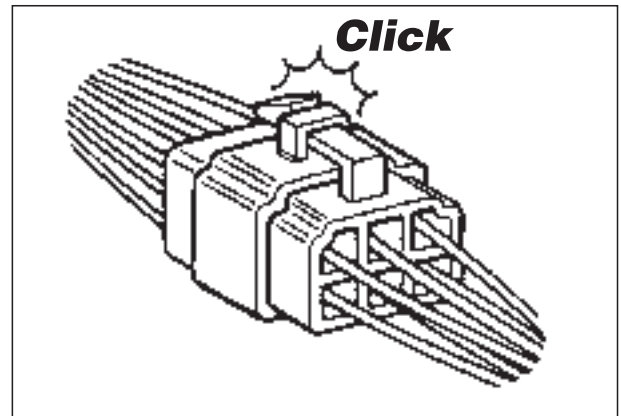

6.2 ELECTRIC COMPONENTS LAYOUT

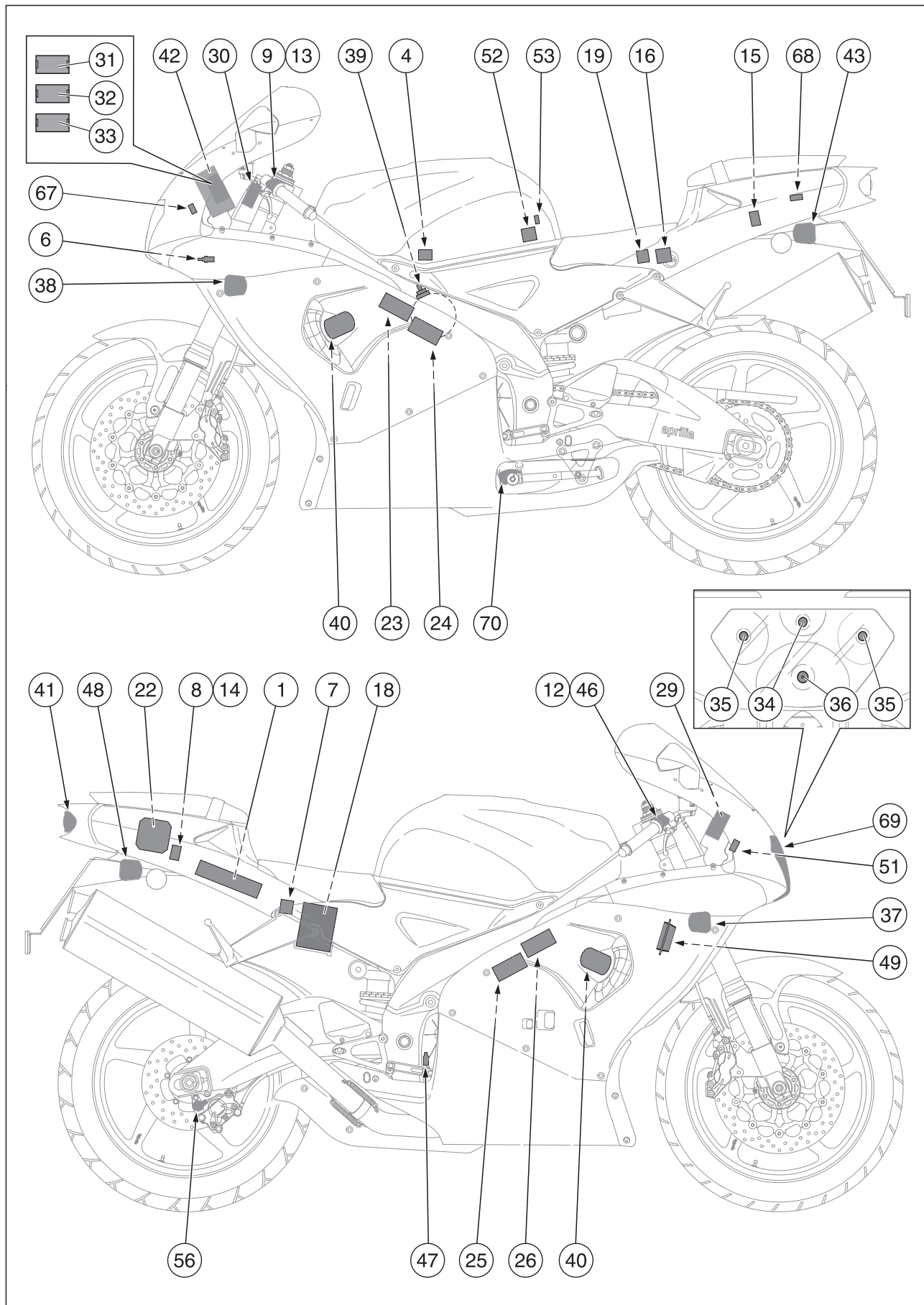

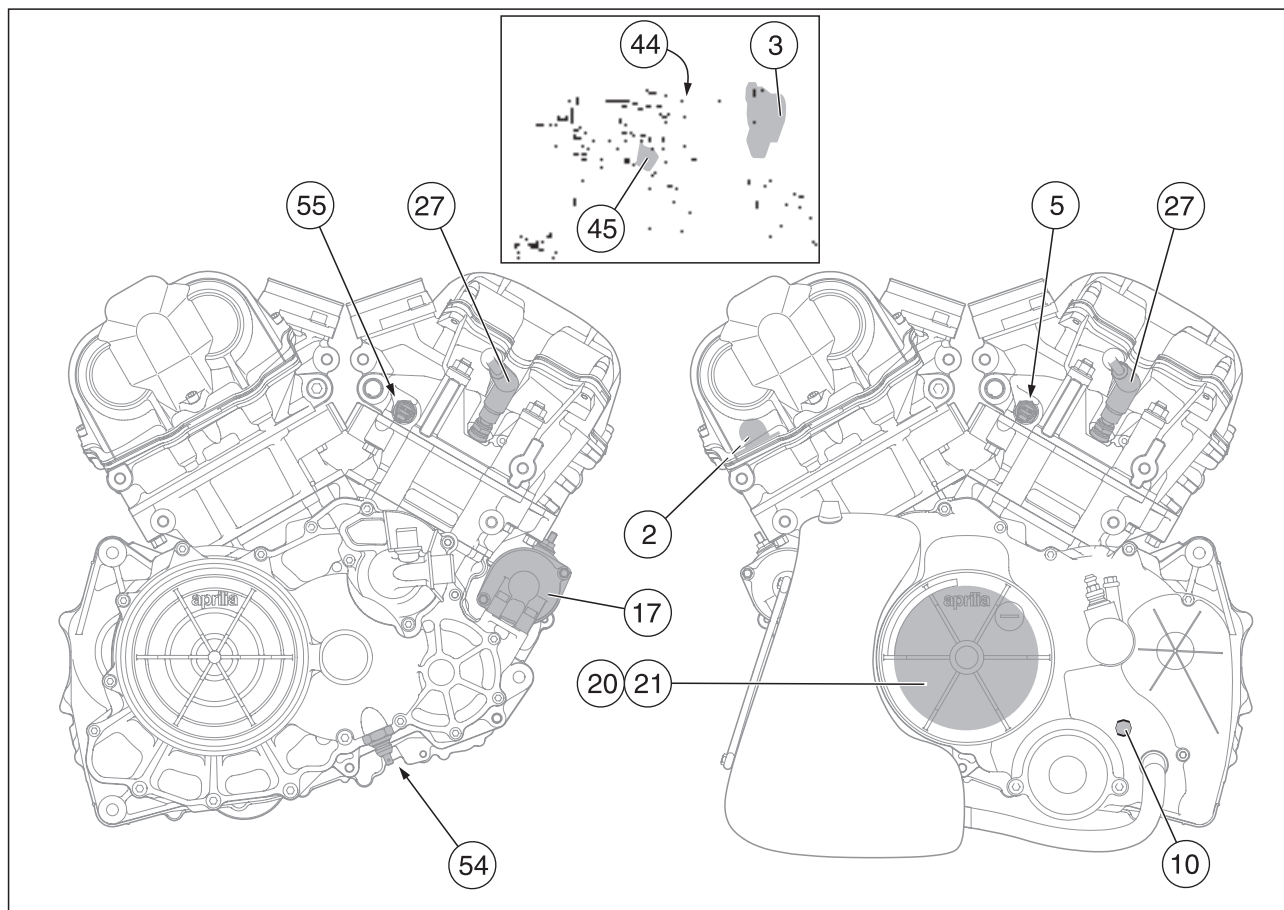

Key

NOTE The numbering corresponds to that on the general wiring diagram.

- | | |
|--|---|
| <ul style="list-style-type: none"> 1) Electronic unit 2) Cam position sensor 3) Throttle valve potentiometer 4) Intake pressure sensor 5) Coolant temperature thermistor (dashboard) 6) Air thermistor 7) Fall sensor 8) Diode module 9) Clutch control lever switch 10) Neutral gear switch 12) Right dimmer switch 13) Left dimmer switch 14) Engine stop relay 15) Fuel pump relay 16) Start relay 17) Starter 18) Battery 19) Main fuses (30A) (ignition) 20) Generator 21) Pick up 22) Voltage regulator 23) Rear cylinder coil "1" 24) Rear cylinder coil "2" 25) Front cylinder coil "1" 26) Front cylinder coil "2" 27) Spark plugs 29) Secondary fuses (15 A) 30) Ignition switch 31) Low beam relay | <ul style="list-style-type: none"> 32) High beam relay 33) Cooling fan relay 34) Front parking light bulb 35) High beam bulbs 36) Low beam bulb 37) Front right direction indicator 38) Front left direction indicator 39) Thermal switch 40) Cooling fans 41) Rear light 42) Dashboard 43) Rear left direction indicator 44) Front cylinder injector 45) Rear cylinder injector 46) Front stoplight switch 47) Rear stoplight switch 48) Rear right direction indicator 49) Horn 51) Blinking 52) Fuel pump 53) Low fuel sensor 54) Engine oil pressure sensor 55) Coolant temperature thermistor (injection) 56) Speed sensor 67) Light diode / LAP 68) TEST connectors 69) Headlight 70) Side stand switch |
|--|---|

6.3 CHECKING THE RECHARGING SYSTEM

6.3.1 CHECKING THE RECHARGING VOLTAGE

- ◆ Check battery voltage, see 2.4.2 (RECHARGING THE BATTERY).
- ◆ Start the engine and let it run until it reaches 4000 rpm.
- ◆ Set the light switch to "☉" and dimmer switch to "☹".
- ◆ **ASD** Set the dimmer switch to "☹".
- ◆ Using a pocket tester, measure the direct voltage between the positive (+) and negative (-) terminals.

If the tester indicates voltage values lower than 13V or higher than 15V:

- ◆ Check the loadless operation and the continuity of the alternator, see 6.3.2 (CHECKING THE ALTERNATOR LOADLESS OPERATION) and 6.3.3 (CHECKING THE ALTERNATOR CONTINUITY).
- ◆ Check the voltage regulator, see 6.3.4 (CHECKING THE VOLTAGE REGULATOR).



Wiring diagram key

NOTE See 6.2 (ELECTRIC COMPONENTS LAYOUT) for the positioning of the components.

- 18) Battery
- 19) Main fuse (30A)
- 20) Generator
- 22) Voltage regulator
- 30) Ignition switch (☉ - ☹ - ☺)

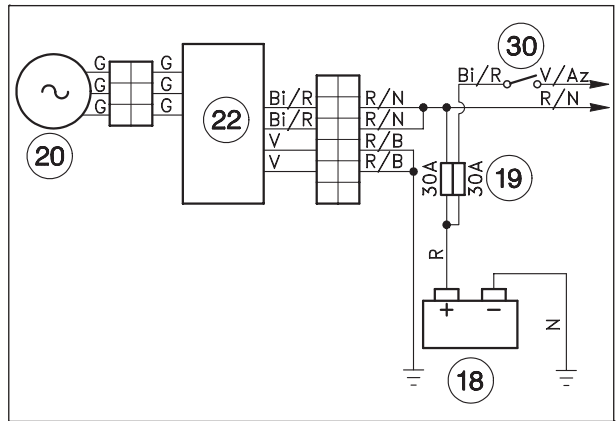

Standard charging voltage:
13 – 15 V (d.c.) at 4000 rpm.

6.3.2 CHECKING THE ALTERNATOR LOADLESS OPERATION

- ◆ Remove the rear fairing, see 7.1.36 (REMOVING THE REAR FAIRING REAR END).
- ◆ Disconnect the three-way connector (1) (coloured brown).

CAUTION

Upon reassembly, make sure that the electric connector (1) is correctly coupled.

- ◆ Start the engine and let it run until it reaches 4000 rpm.
- ◆ Using a pocket tester, measure the voltage (a.c.) from the three internal male terminals [yellow cables (G)] in rotation.

If the value indicated by the tester is lower than 60 V, the alternator is faulty and needs replacing.

Standard loadless voltage:
more than 60 V (a.c.) at 4000 rpm.

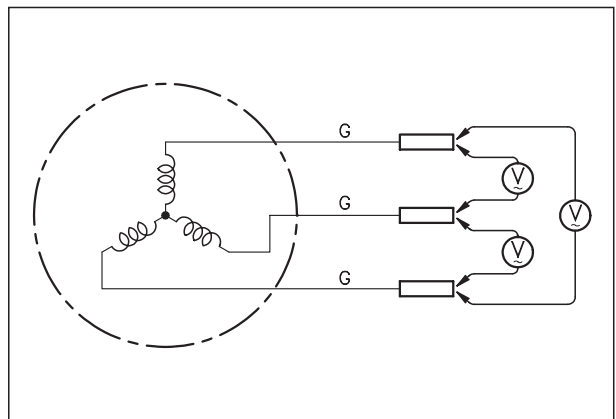
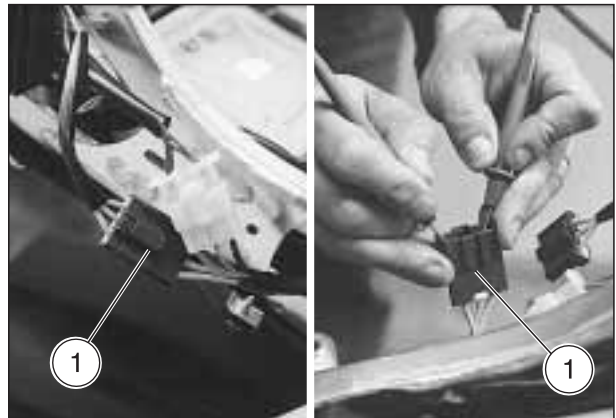

6.3.3 CHECKING THE ALTERNATOR CONTINUITY

With the engine switched off:

- ◆ Remove the rear fairing, see 7.1.36 (REMOVING THE REAR FAIRING REAR END).
- ◆ Disconnect the three-way connector (1) (coloured brown).

⚠ CAUTION

Upon reassembly, make sure that the electric connector (1) is correctly coupled.

- ◆ Using a pocket tester (Ω scale), check for breaks between the cables of the stator [on the internal male terminals, yellow cables (G)].
- Also check the isolation of the stator mount.

Standard resistance value: 0.1 – 1 Ω .

Standard resistance value (between cables and stator mount): ∞ .

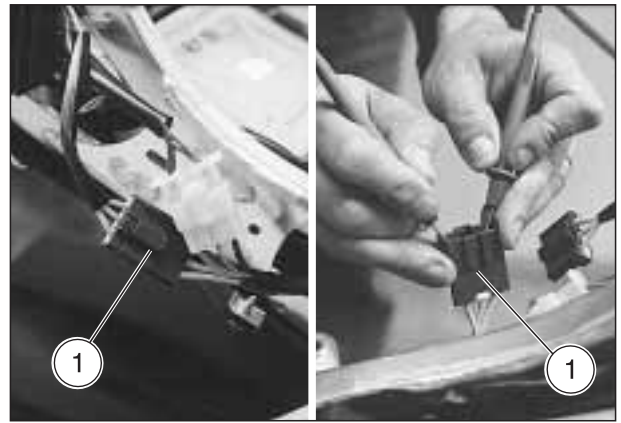

6.3.4 CHECKING THE VOLTAGE REGULATOR

- ◆ Remove the rear fairing, see 7.1.36 (REMOVING THE REAR FAIRING REAR END).
- ◆ Disconnect the three-way connector (1) (coloured brown).
- ◆ Disconnect the six-way connector (2) (coloured white).

⚠ CAUTION

When reassembling, make sure the electric connectors (1) (2) are plugged in properly.

- ◆ Using a pocket tester (scale x 1M Ω), measure the resistance between the cables indicated in the table below from the regulator side (internal female terminals).

NOTE The green (V) and white/red (Bi/R) cables are double, though connected together.

Take the measurements on either of the two.

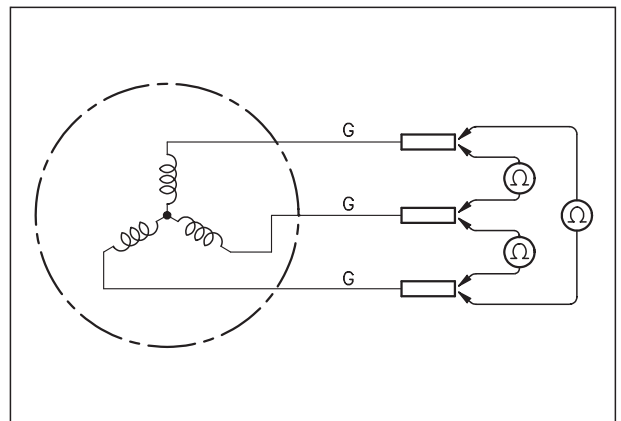

		Positive terminal (+) of the tester on:				
		G	G	G	V	R/Bi
Negative terminal (-) of the tester on:	G		∞	∞	2 – ∞	∞
	G	∞		∞	2 – ∞	∞
	G	∞	∞		2 – ∞	∞
	V	∞	∞	∞		∞
	R/Bi	2 – ∞	2 – ∞	2 – ∞	3 – ∞	

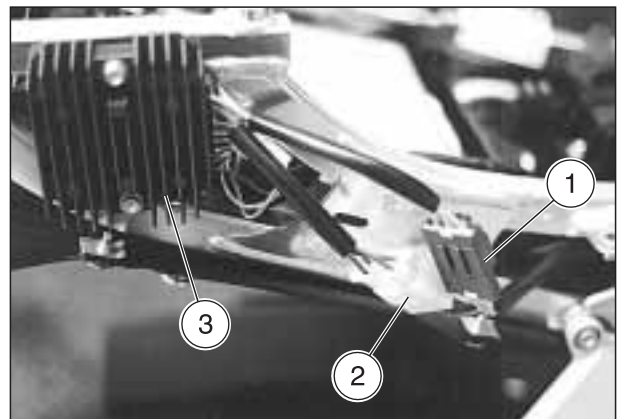

⚠ CAUTION

This measuring method is approximate; if possible, check the correct operation of the recharging system using another regulator in perfect condition.

If the resistance measured is incorrect, replace the voltage regulator (3).

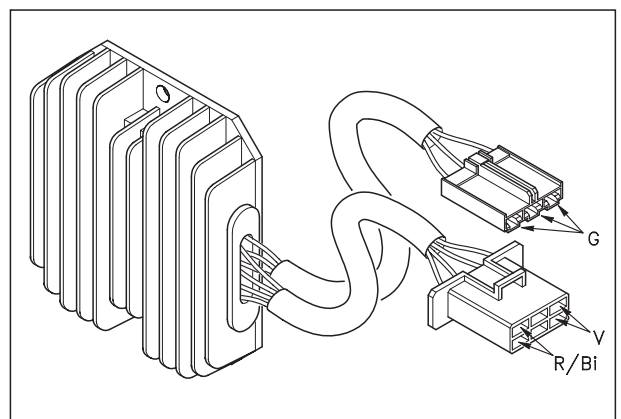

6.4 IGNITION SYSTEM

6.4.1 WIRING DIAGRAM

NOTE See 6.2 (ELECTRIC COMPONENTS LAYOUT) for the positioning of the components.

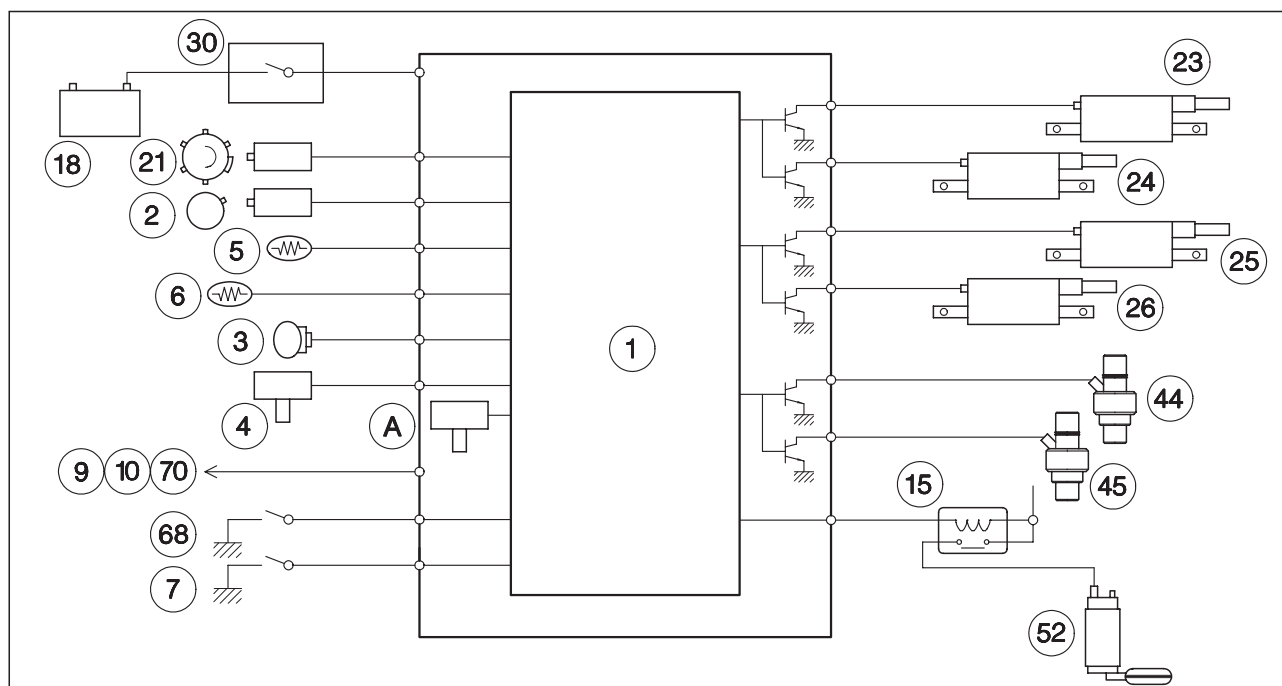

Wiring diagram key

- | | |
|--|-----------------------------------|
| A) Intake pressure sensor (inside electronic unit) | 21) Driving shaft position sensor |
| 1) Electronic unit | 23) Rear cylinder coil "1" |
| 2) Camshaft position sensor | 24) Rear cylinder coil "2" |
| 3) Throttle valve potentiometer | 25) Front cylinder coil "1" |
| 4) Intake pressure sensor | 26) Front cylinder coil "2" |
| 5) Coolant thermistor | 30) Ignition switch |
| 6) Air thermistor | 44) Front cylinder injector |
| 7) Fall sensor | 45) Rear cylinder injector |
| 9) Clutch control lever switch | 52) Fuel pump |
| 10) Neutral gear switch | 68) TEST connectors |
| 15) Fuel pump relay | 70) Side stand switch |
| 18) Battery | |

6.4.2 TROUBLESHOOTING (IF THE ENGINE DOES NOT START)

Locating a fault in the electrical system

- ◆ Position the vehicle on the stand.
- ◆ Turn the ignition switch to position "0".
The message "EF" comes up on the right-hand display for approx. three seconds.
- ◆ Press the start pushbutton "⊙" for more than four seconds.
If the ignition system is malfunctioning, the message "EF" reappears.

NOTE If a fault is detected in the electronic system or if the "EF" message flashes on the multifunction display, do not start the vehicle so as to avoid secondary damage.

If the ignition system is malfunctioning and the message "EF" fails to reappear, make sure there are no breaks in the white/purple (Bi/Vi) cable between the electronic unit and the display.

- ◆ Remove the right side panel, see 7.1.3 (REMOVING THE SIDE COVERS).
- ◆ Connect the two "TEST" terminals (1) with each other.
- ◆ Turn the ignition switch to position "0".
- ◆ Start the engine or attempt to start it.

The message "DIAG" comes up on the left display along with a number corresponding to the reference code relating to the fault (see table); the fault detected may be caused by breaks in the cables and/or connections not made properly.

Checking an electric system fault:

CAUTION

Before commencing the automatic search for a fault, stop the engine.

NOTE When a fault comes up on the display, it is possible that the fault may also be attributable to the engine control unit.

The ECU may only be tested by connecting a new ECU.

Should the engine control unit work properly, remember to refit the previous unit.

The ECU features an anti-breakdown device which, where necessary, means the engine can be started and run despite there being a fault on the display.

Follow ►

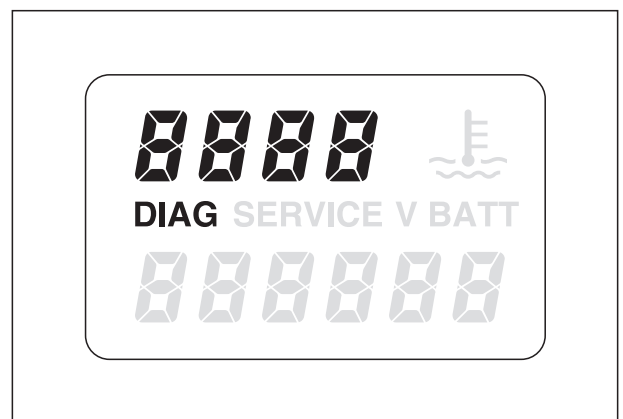
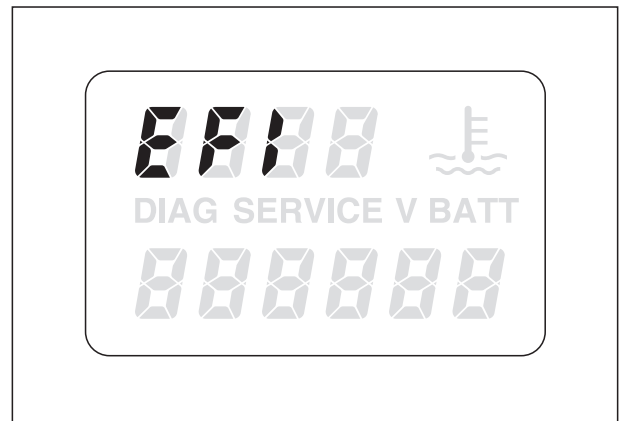

Follow ►

Component	Fault code	Cause	To view "E F I" on the display	Components to be checked	Starting motor running	Engine runs	Engine runs (emergency conditions)
Camshaft position sensor	11	Sensor not connected. Sensor broken. Wiring faulty.	Press the starter button for more than four seconds.	Connector, sensor cable and sensor	Yes	No (the cylinder cannot be identified)	No
Driving shaft position sensor	12				Yes	No	
Intake pressure sensor	13				Excessive difference between the sensor signals.	Engine shut off	Sensor pipes (air pipe)
Intake pressure sensor	14	Sensor not connected. Sensor broken. Wiring faulty.	Engine running or engine shut off	Connector, sensor cable and sensor			
Throttle valve potentiometer	15				Yes (cold-starting difficult)	Yes	
Coolant thermistor	21						Yes
Air thermistor	22	Sensor faulty	Cannot be checked: replace the ECU	Yes	Yes		
Atmospheric pressure sensor (ECU inside)	23					Ignition coil faulty or wiring not connected	Engine running
Ignition coil "1" of front cylinder	33						
Ignition coil "2" of front cylinder	34	Yes (only one cylinder, power loss)	Yes (only one cylinder, power loss)				
Ignition coils "1" and "2" of front cylinder	33, 34						
Ignition coil "1" of rear cylinder	35	Yes (power loss)	Yes (power loss)				
Ignition coil "2" of rear cylinder	36						
Ignition coils "1" and "2" of rear cylinder	35, 36	Yes	Yes (only one cylinder, power loss)	Yes (only one cylinder, power loss)			
Fall sensor	41				Sensor not connected. Sensor broken. Wiring faulty.	Engine running or engine shut off	Connector, sensor cable and sensor

6.4.3 ELIMINATING ELECTRONIC SYSTEM FAULTS ACCORDING TO THE INFORMATION SENT UP ON THE DISPLAY

⚠ WARNING

Take care around the high voltage in the ignition system.

Never disconnect connections with the engine running.

Whenever work is performed in the ignition system, always make sure the ignition switch is set to "⊗" and the battery disconnected, unless otherwise indicated (when disconnecting the battery, disconnect the negative pole "-" first).

⚠ CAUTION

All measurements must be taken with the components at a temperature of 20 °C (68 °F).

General instructions regarding the elimination of faults: as soon as the fault has been located, remove the defective component.

- ◆ Perform the checks indicated in the following chapters:
 - 6.4.6 (CHECKING THE CAMSHAFT POSITION SENSOR);
 - 6.4.5 (CHECKING THE PICK-UP);
 - 6.4.11 (CHECKING THE INTAKE PRESSURE SENSOR);
 - 6.4.10 (CHECKING THE THROTTLE VALVE POTENTIOMETER);
 - 6.4.8 (CHECKING THE COOLANT THERMISTOR OPERATION).

If the engine does not start and the diagnostics fail to detect any fault, check (in the given order) whether:

- the fuel pump is working properly, see 6.5.2 (CHECKING THE FUEL PUMP);
- the injectors are working properly, see 6.4.12 (CHECKING THE INJECTORS);
- the connector for the antitheft device fitting is connected properly (located under the passenger seat and coloured white);
- the ignition switch is working properly, see 6.7 (SWITCHES);
- the engine shutoff switch is working properly, see 6.7 (SWITCHES);
- the main 30A fuses and secondary 15A fuses have blown, see 6.15 (CHANGING THE FUSES);
- the engine shutoff relay is working properly, see 6.5.4 (CHECKING THE ENGINE SHUTOFF RELAY);
- the battery is working properly, see 2.4 (BATTERY) and 6.11 (BATTERY);
- the safety logic is working properly, see 6.6 (IGNITION SAFETY SYSTEM);
- the fall sensor is working properly, see 6.4.7 (CHECKING THE FALL SENSOR).

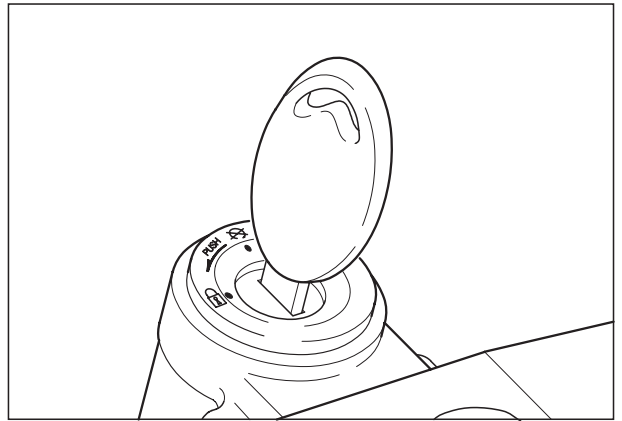

6.4.4 CHECKING THE IGNITION COILS

- ◆ Remove both side fairings, see 7.1.28 (REMOVING THE SIDE FAIRINGS).

NOTE The following procedure refers to a single coil, though it is applicable to both.

- ◆ Disconnect the terminals (1) (2) from the ignition coil (3).

CAUTION

Upon reassembly, make sure that the electric terminals (1) (2) are properly connected.

- ◆ Slip off the spark plug cap (4) (belonging to the coil of interest) and disconnect it from the cable.
- ◆ Measure the values of (A) and (B) indicated in the figure by means of a pocket tester.

It is important to check the continuity of the primary and secondary windings.

The reading in Ohms does not necessarily have to be exact but if the windings are sound, the resistance values must correspond approximately to those indicated.

Standard values:

measurement (A): 2.8 – 5.2 Ω;

measurement (B): 9.1 – 16.5 kΩ.

CAUTION

This measuring method is approximate; if possible, check the correct operation of the coil by replacing it with another one in perfect condition.

- ◆ Repeat the procedure for the other coils.

NOTE Sometimes the coils, when they are cold, do not give the values indicated above, but they start functioning correctly when the vehicle reaches its normal running temperature.

If the vehicle functions correctly when cold, but successively, when it reaches the normal running temperature, the current output in the electric system is suddenly interrupted, this may be due to the fact that the coils are broken and need replacing.

6.4.5 CHECKING THE PICK-UP

With the engine switched off:

- ◆ Lift the fuel tank, see 2.8 (LIFTING THE FUEL TANK).
- ◆ Disconnect the two-way connector (5) (coloured white) and take the measurements (on the engine-side terminals).

CAUTION

Upon reassembly, make sure that the electric connector (5) is correctly coupled.

- ◆ Using a pocket tester (scale x 100 Ω), measure the resistance between the terminals of the blue/yellow (B/G) and white/yellow (Bi/G) cables.

Standard value: 150 – 350 Ω.

If the resistance is infinite (∞) or lower than the prescribed level, the sensor must be changed.

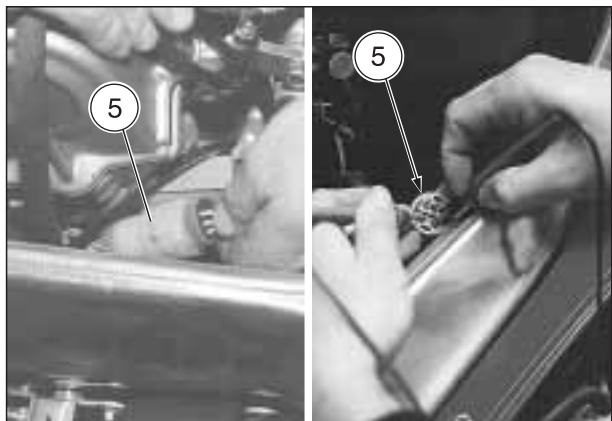
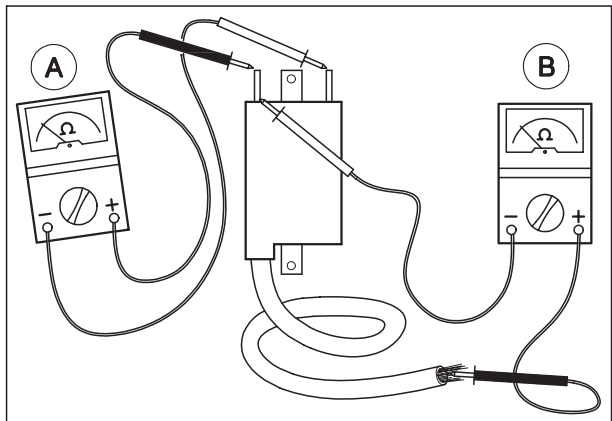
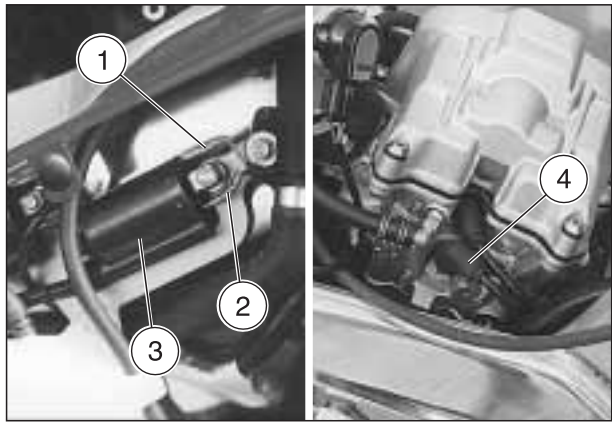

6.4.6 CHECKING THE CAMSHAFT POSITION SENSOR

With the engine switched off:

- ◆ Lift the fuel tank, see 2.8 (LIFTING THE FUEL TANK).
- ◆ Disconnect the two-way connector (1) (coloured white) and take the measurements (on the engine-side terminals).

⚠ CAUTION

Upon reassembly, make sure that the electric connector (6) is correctly coupled.

- ◆ Using a pocket tester (scale x 100 Ω), measure the resistance between the terminals of the blue/yellow (B/G) and white/yellow (Bi/G) cables.

Standard value: 150 – 350 Ω .

If the resistance is infinite (∞) or lower than the prescribed level, the sensor must be changed.

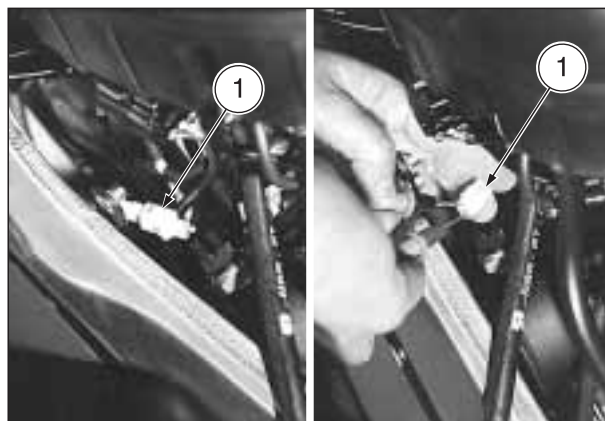

6.4.7 CHECKING THE FALL SENSOR

With the engine switched off:

- ◆ Put back the rider saddle, see 7.1.1 (REMOVING THE RIDER SADDLE).

Check whether the sensor (2) is fitted correctly (with the arrow inscribed on the rubber element pointing up).

- ◆ Disconnect the two-way connector (3) (coloured white/grey) and take the measurements (on the sensor-side terminals).

⚠ CAUTION

Upon reassembly, make sure that the electric connector (3) is correctly coupled.

- ◆ Using a pocket tester (scale x 100 k Ω), measure the resistance between the terminals of the black and white/black (N - Bi/N) cables).

Standard value: resistance 62 k Ω \pm 15 %.

- ◆ Remove the sensor (2) complete with rubber element from its housing and tilt it sideways at an angle of over 45° (simulating the condition of a vehicle resting on the ground).

Standard value: 0 – 1 Ω .

If the resistance is any value other than that prescribed, the sensor (1) must be changed.

- ◆ Repeat the procedure, tilting the sensor in the opposite direction.

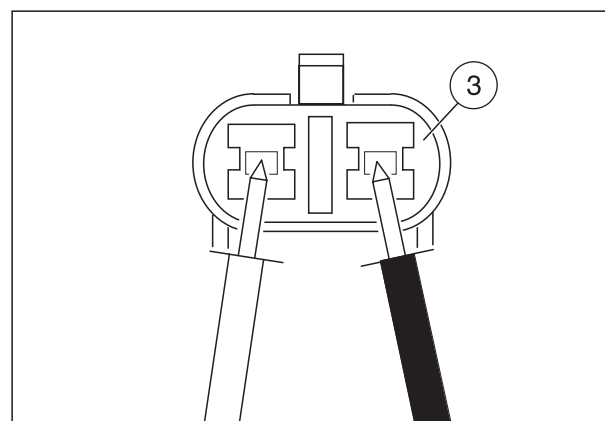
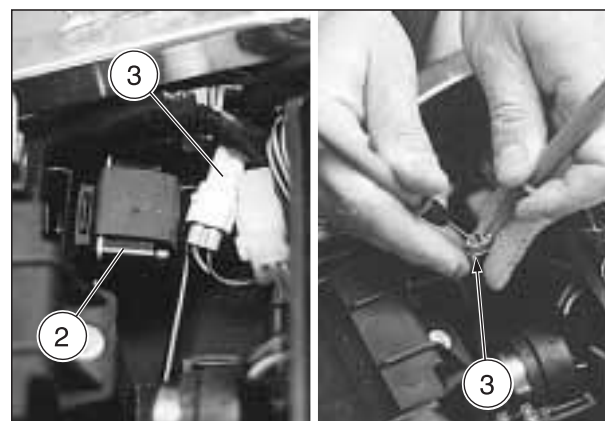

6.4.8 CHECKING THE COOLANT THERMISTOR OPERATION

NOTE The value of the temperature measured by the front cylinder thermistor (right-hand side) is sent up on the right-hand display; that measured by the rear cylinder thermistor (left-hand side) is sent to the electronic unit.

- ◆ Remove the thermistor (1), see 5.5 (REMOVING THE COOLANT THERMISTORS).
- ◆ Connect a tester (2) (set as an ohmmeter) to the thermistor (1), as illustrated in the figure.
- ◆ Immerse the thermistor (1) in a container (3) holding coolant.
- ◆ Immerse a thermometer (4) with a 0 – 150 °C (32 – 302 °F) range in the same container.
- ◆ Place the container on a burner (5) and slowly warm up the liquid.
- ◆ Check the temperature indicated on the thermometer (4) and the thermistor (1) value indicated by the tester.

Make sure that the value varies according to the temperature, as indicated.

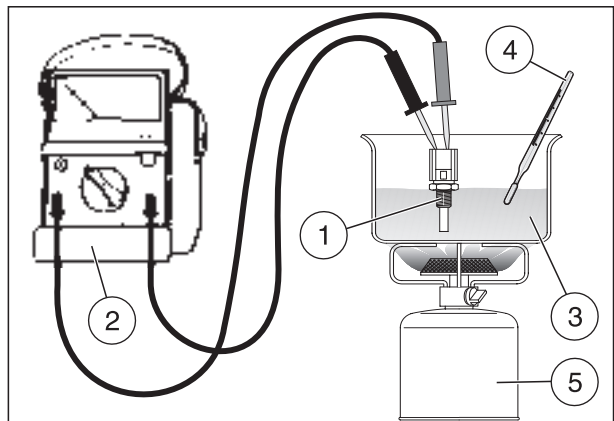
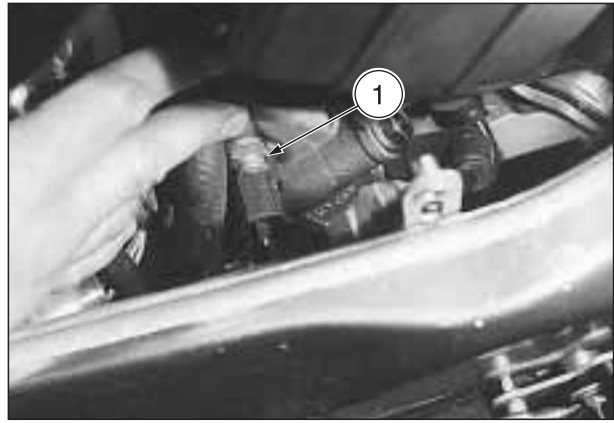

Coolant temperature		Standard values (Ω) (± 10%)
(°C)	(°F)	
20	68	1960 – 2940
40	104	800 – 1200
60	140	400 – 700
80	176	200 – 400
100	212	120 – 250

If values do not vary, or if they depart excessively from those indicated in the table, change the thermistor (1).

- ◆ Repeat the procedure for the other thermistor.

6.4.9 CHECKING THE AIR THERMISTOR OPERATION

- ◆ Remove the left-hand conveyor cover, see 7.1.31 (REMOVING THE AIR CONVEYOR COVERS).
- ◆ Disconnect the two-way connector (1) (coloured green).

⚠ CAUTION

Upon reassembly, make sure that the electric connector (1) is correctly coupled.

- ◆ Unscrew and remove the thermistor (2).
- ◆ Connect a tester (3) (set as an ohmmeter) to the thermistor (2), as illustrated in the figure.
- ◆ Immerse the thermistor in a container (4) holding water.
- ◆ Immerse a thermometer (5) with a 0 – 150 °C (32 – 302 °F) range in the same container).
- ◆ Place the container on a burner (6) and slowly warm up the liquid.
- ◆ Check the temperature indicated on the thermometer (5) and the thermistor value indicated by the tester.

Make sure that the value varies according to the temperature, as indicated.

Water temperature		Standard values (Ω) ($\pm 10\%$)
(°C)	(°F)	
20	68	1960 – 2940
40	104	800 – 1200
60	140	400 – 700
80	176	200 – 400
100	212	120 – 250

If values do not vary, or if they depart excessively from those indicated in the table, change the thermistor (2).

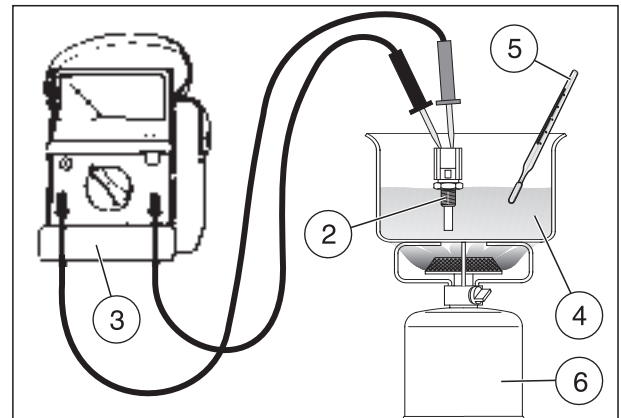
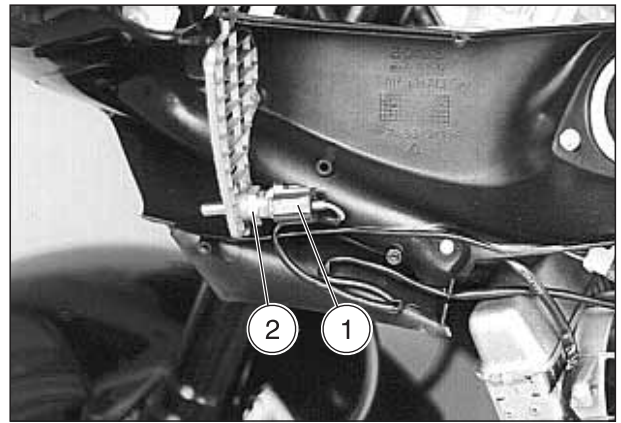

6.4.10 CHECKING THE THROTTLE VALVE POTENTIOMETER

With the engine switched off:

- ◆ Lift the fuel tank, see 2.8 (LIFTING THE FUEL TANK).
- ◆ Disconnect the four-way connector (1) (coloured black).

⚠ CAUTION

Upon reassembly, make sure that the electric connector (1) is correctly coupled.

- ◆ Turn the ignition switch to position "O".
- ◆ By means of a tester, measure the supply voltage between the external terminals of the connector (1); measure (A);

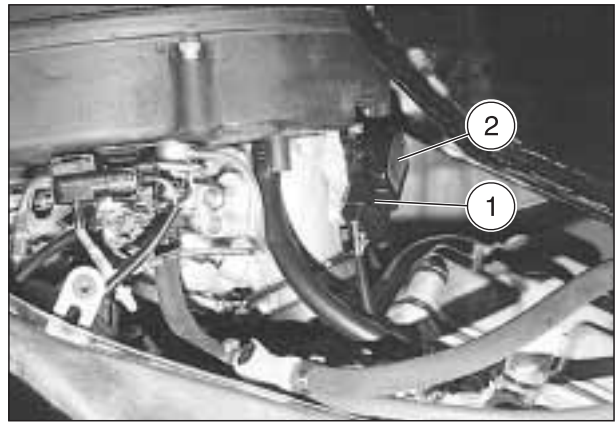

MEASUREMENT (A)

Standard value: 4.5 – 5.5 V.

- ◆ Turn the ignition switch to position "O".
- ◆ Using a tester (kΩ scale), measure the resistance between the potentiometer terminals (2); measurement (B) and (C);

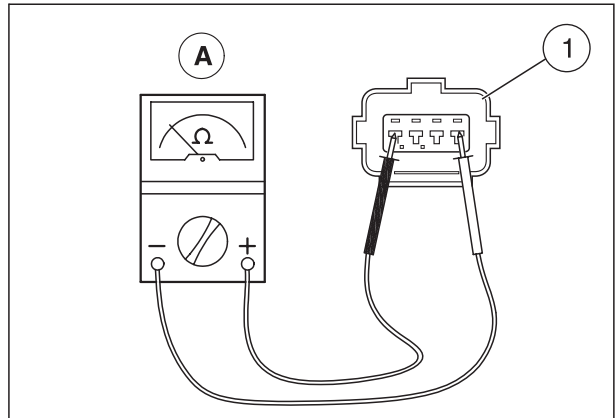

MEASUREMENT (B)

Resistance between the two terminals whatever the position of the throttle valves:

Standard value: 2.87 – 5.33 kΩ.

MEASUREMENT (C)

Starting with the throttle valve fully closed, accelerating progressively until completely open, the resistance should vary as follows;

standard value:

- with throttle valves closed 0.34 – 5.69 kΩ;
- with throttle valves open 2.87 – 8.41 kΩ.

⚠ CAUTION

The two M4x12 screws (3) fastening the throttle valve potentiometer are painted and can only be removed in the event the actual sensor is replaced.

NOTE In order to make it easier to unscrew the screws (3) secured using LOCTITE® 243, heat them first with a hot air blower.

Screws (3) driving torque: 1.6 Nm (0.16 kgm).

- ◆ Unscrew and remove the two screws (3).
- ◆ Remove the potentiometer (2) and make sure that the inner spring is not broken.
- ◆ Using a pocket tester (scale kΩ), measure the resistance between the terminals of the potentiometer (2);

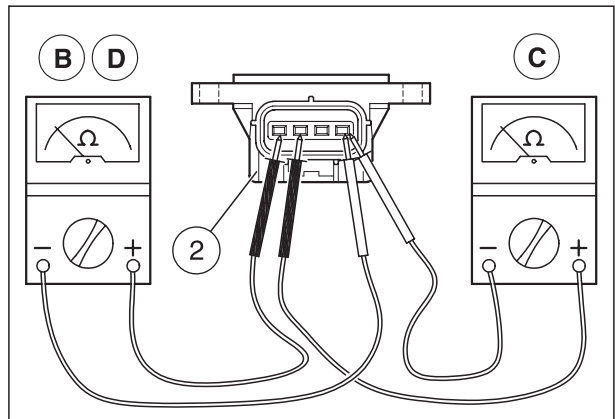

MEASUREMENT (D)

Standard value

- with potentiometer in rest position < 5.2 kΩ;
- with potentiometer rotated to the end of stroke 3.34 – 8.88 kΩ.

If the measurements result in any resistance values other than those given, replace the potentiometer (2).

NOTE For the reassembly or replacement of the potentiometer (2), see 4.8.9 (CHANGING AND ADJUSTING THE THROTTLE VALVE POTENTIOMETER).

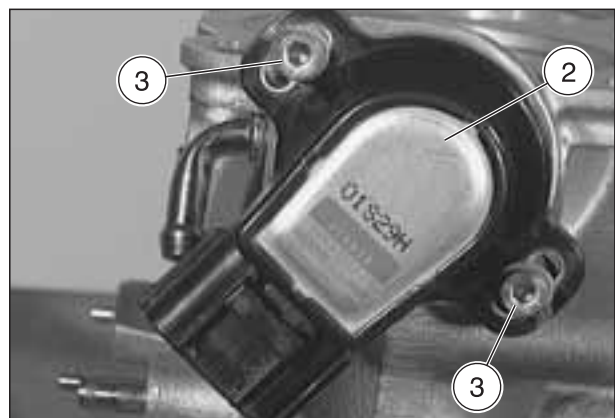

6.4.11 CHECKING THE INTAKE PRESSURE SENSOR

With the engine switched off:

- ◆ Lift the fuel tank, see 2.8 (LIFTING THE FUEL TANK).
- ◆ Disconnect the three-way connector (1) (coloured black).

CAUTION

Upon reassembly, make sure that the electric connector (1) is correctly coupled.

- ◆ Turn the ignition switch to position "O".
- ◆ By means of a tester, measure the supply voltage between the external terminals of the connector (1); measure (A).

Standard value: 4.5 – 5.5 V.

- ◆ Turn the ignition switch to position "⊗".
- ◆ Using a pocket tester (scale kΩ), measure the resistance between the terminals of the sensor (2).

NOTE Measurements (B), (C) and (D) must be taken individually, not at the same time.

Measurements (B), (C) and (D) must produce the following values:

Standard values:

- measurement (B) $12\text{ k}\Omega \pm 10\%$;
- measurement (C) $11.50\text{ k}\Omega \pm 10\%$;
- measurement (D) $4\text{ k}\Omega \pm 10\%$.

If the resistance proves to be any value other than that prescribed, the sensor (2) must be changed.

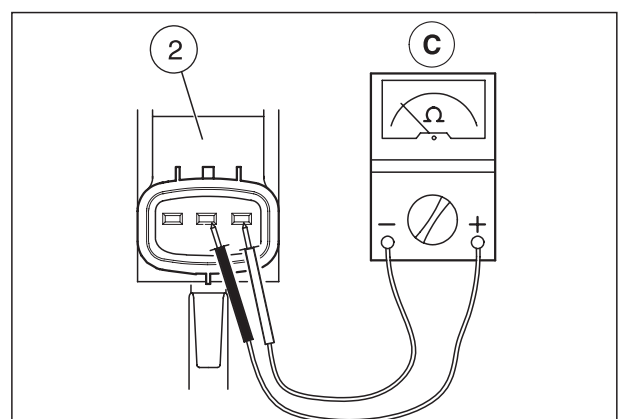
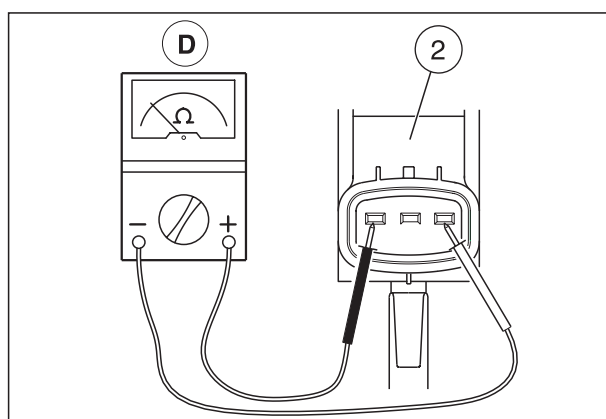
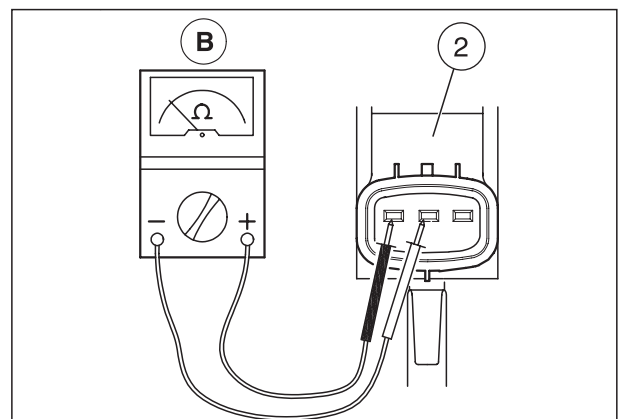
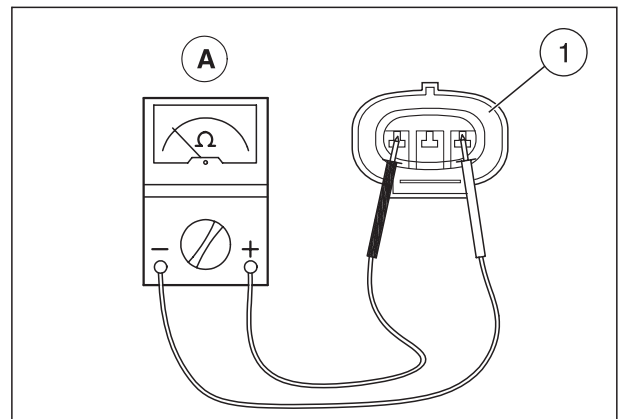
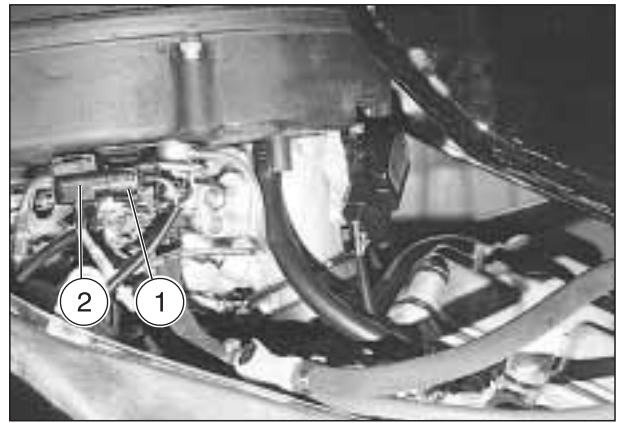

6.4.12 CHECKING THE INJECTORS

With the engine switched off:

- ◆ Lift the fuel tank, see 2.8 (LIFTING THE FUEL TANK).

NOTE The following procedure refers to a single injector, though it is applicable to both.

- ◆ Disconnect the two-way connector (1) (coloured grey) and take the measurements (on the injector-side terminals).
- ◆ Using a pocket tester (scale 100 Ω), measure the resistance between the terminals of the injector.

Standard value: 11 – 17 Ω to 20 °C (68 °F).

If the resistance is infinite (∞) or lower than the prescribed level, the injector (2) must be changed.

- ◆ Repeat the procedure for the other injector.

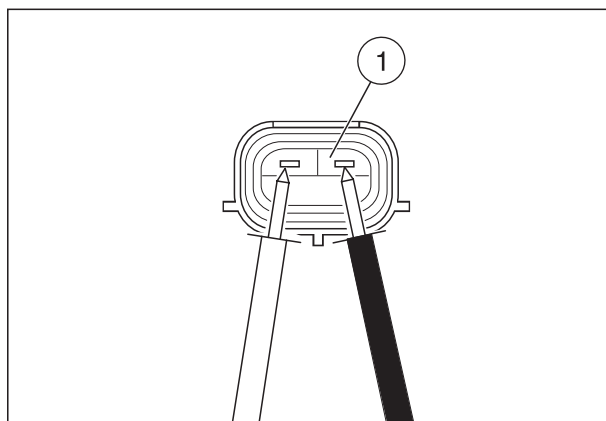
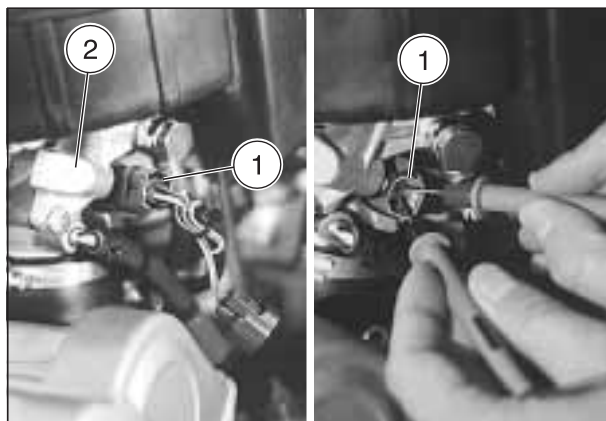

6.5 FUEL PUMP SYSTEM

6.5.1 WIRING DIAGRAM

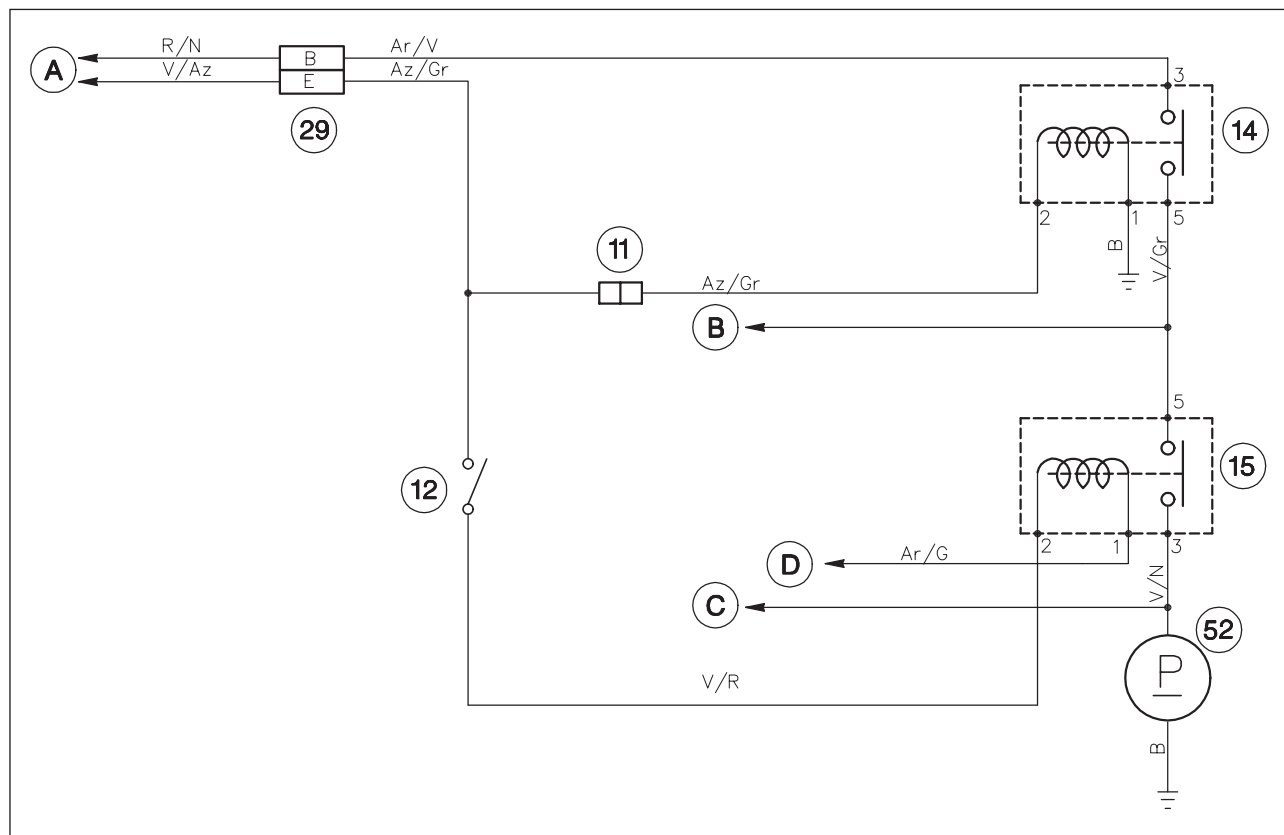

NOTE See 6.2 (ELECTRIC COMPONENTS LAYOUT) for the positioning of the components.

Wiring diagram key

- 11) Arrangement for the installation of the anti-theft device
- 12) Engine stop switch
- 14) Engine stop relay
- 15) Fuel pump relay
- 29) Secondary fuses (15 A)
- 52) Fuel pump
- A) To the battery / ignition switch
- B) To the HV coil
- C) To the injectors / electronic unit
- D) To the electronic unit

6.5.2 CHECKING THE FUEL PUMP

In order to check the pump is operating properly:

- ◆ Lift the fuel tank, see 2.8 (LIFTING THE FUEL TANK).
- ◆ Disconnect the pump units three-way connector (1) (coloured white).

⚠ CAUTION

Upon reassembly, make sure that the electric connector (1) is correctly coupled.

⚠ CAUTION

Place a cloth under the perforated screw (2) to catch any fuel spills.

- ◆ Loosen the perforated screw (2) by approx. half a turn and wait a few seconds to allow the system to depressurize.

⚠ WARNING

Fire and/or explosion hazard.

After removal, keep the fuel delivery pipe (3) in vertical position, thus preventing the fuel from flowing out.

- ◆ Unscrew and remove the perforated screw (2), taking the two seals (4) and (5).

Perforated screw (2) driving torque: 22 Nm (2.2 kgm).

⚠ WARNING

Upon reassembly, change the two gaskets (4) and (5) and tighten the perforated screw (5) applying the prescribed torque in order to ensure perfect seal. This is essential, since the injection pressure is approx. 450 kPa (4.5 bar) and any fuel leakage would prove extremely dangerous, in fact the leaking fuel might end up on high-temperature parts of the engine.

NOTE Have the appropriate special tools **OPT** to hand:

- aprilia part# 8140197 (perforated bolt for fuel pressure test fuel) (6);
- aprilia part# 8140181 (fuel-oil pressure gauge-compression) (7);

and two gaskets (8) and (9) to replace the original ones (4) and (5) upon reassembly.

- ◆ Install the following components, in the given order:

- seal (8);
- fuel delivery pipe (3);
- seal (9);
- perforated bolt (6);
- fuel-oil pressure gauge (7).

- ◆ Power the positive (+) green (V) and negative (-) blue (B) cables with a voltage of 12 V (d.c.) (from the pump unit side).

- ◆ Make sure the pump is working and produces the characteristic humming sound and check the pressure gauge gives a supply pressure reading of at least 350 kPa (3.5 bar).

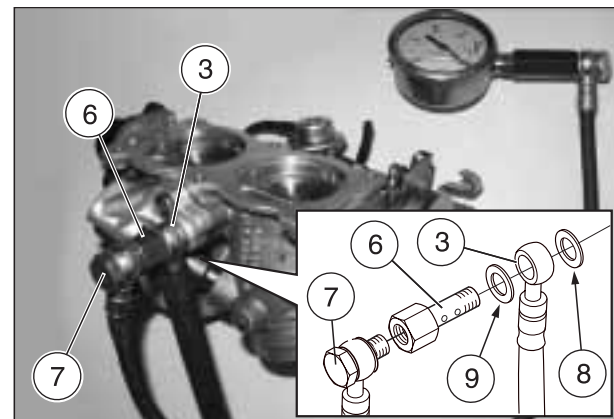
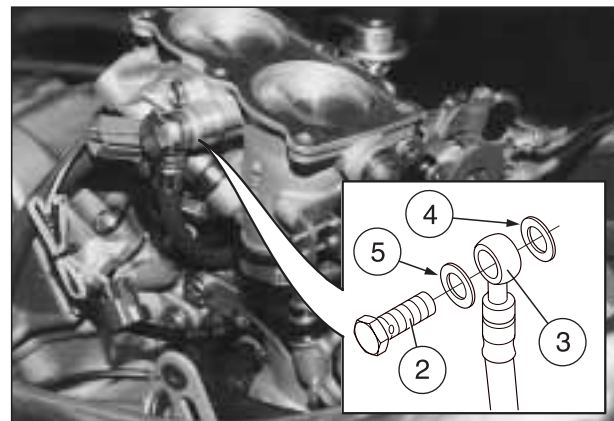
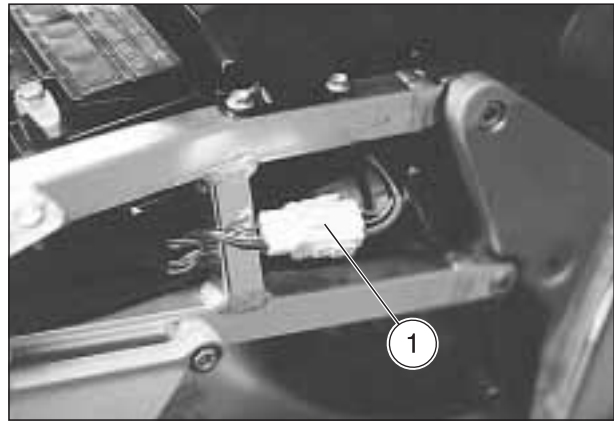

6.5.3 CHECKING THE FUEL PUMP RELAY

- ◆ Remove the passenger seat, see 7.1.2 (UNLOCKING/ LOCKING THE PASSENGER SEAT).

In order to check the operation of the relay:

- ◆ Disconnect the four-way connector (1) (coloured white) from the relay (2).

⚠ CAUTION

Upon reassembly, make sure that the electric connector (1) is correctly coupled.

- ◆ Power the two internal male terminals "1" – "2" at 12 V .
- ◆ Using a tester (acting as ohmmeter), check for breaks between the other two terminals "3" – "5".

Correct value with relay powered: 0 Ω .

Correct value with relay not powered: $\infty \Omega$.

If the resulting values do not correspond to those indicated, change the relay (2).

6.5.4 CHECKING THE ENGINE SHUTOFF RELAY

The procedure is exactly the same as that used to check the fuel pump relay, see 6.5.3 (CHECKING THE FUEL PUMP RELAY).

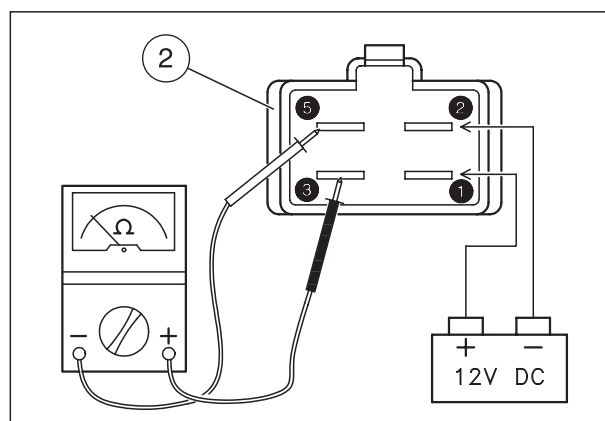
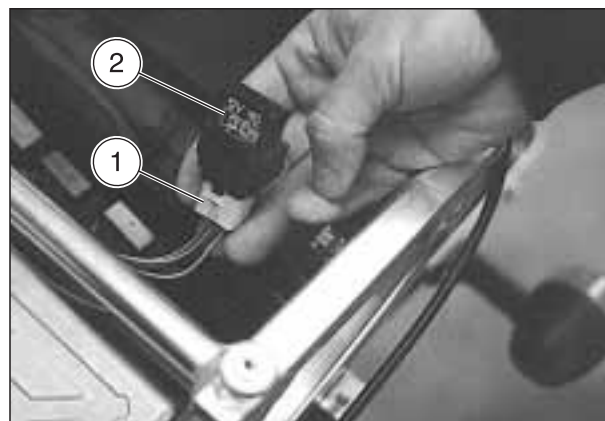

6.6 IGNITION SAFETY SYSTEM

6.6.1 WIRING DIAGRAM

NOTE See 6.2 (ELECTRIC COMPONENTS LAYOUT) for the positioning of the components.

Wiring diagram key

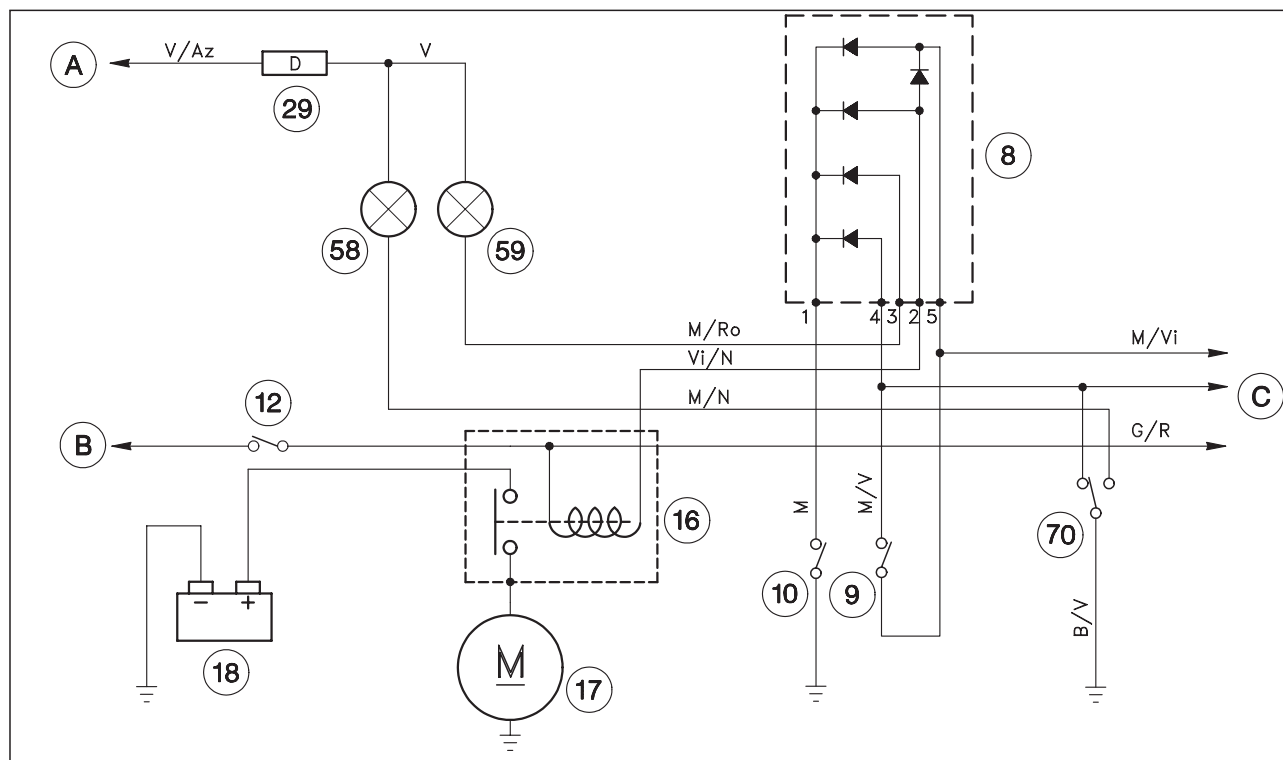

- 8) Diode module
 - 9) Clutch control lever switch
 - 10) Neutral gear switch
 - 12) Start push button
 - 16) Start relay
 - 17) Starter
 - 18) Battery
 - 29) Secondary fuses (15 A)
 - 58) Side stand down warning light
 - 59) Neutral warning light
 - 70) Stand switch
- A) To the battery / ignition switch
 B) To the secondary fuses (15 A)
 C) To the electronic unit

6.6.2 STARTING SAFETY OPERATING LOGIC

NOTE With the engine shutoff switch in position "⊗" the starter motor does not turn over.

GEAR POSITION	STAND POSITION	CLUTCH LEVER	STAND WARNING LIGHT	ENGINE IGNITION	STARTER
IN NEUTRAL	UP	PULLED UP	OFF	WORKING	TURNING OVER
		RELEASED			
	DOWN	PULLED UP	ON		
		RELEASED			
GEAR ENGAGED	UP	PULLED UP	OFF	NOT WORKING	NOT TURNING OVER
		RELEASED			
	DOWN	PULLED UP	ON		
		RELEASED			

6.6.3 CHECKING THE STARTING RELAY

In order to check the operation of the relay:

- ◆ Put back the rider saddle, see 7.1.1 (REMOVING THE RIDER SADDLE).
- ◆ Disconnect the two-way connector (1) (coloured white).

CAUTION

Upon reassembly, make sure that the electric connector (1) is correctly coupled.

- ◆ Lift the relay and slip it off the relevant couplings (2).
- ◆ Slip off the two rubber protections (3) (4).
- ◆ Disconnect the cables (5) (6) from the relevant terminals on the relay (2).
- ◆ From the relay side, power the two internal terminals of connector (1) at 12V.
- ◆ Using a tester (acting as ohmmeter), check for breaks between the two screw contacts on the relay (2).

Correct value with relay powered: 0 Ω.

Correct value with relay not powered: ∞ Ω.

If the resulting values do not correspond to those indicated, change the relay (2).

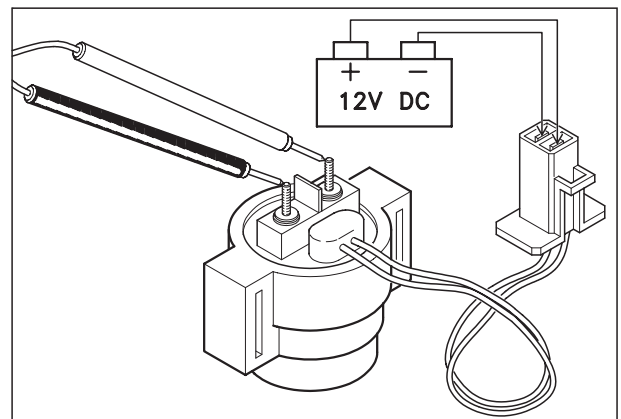
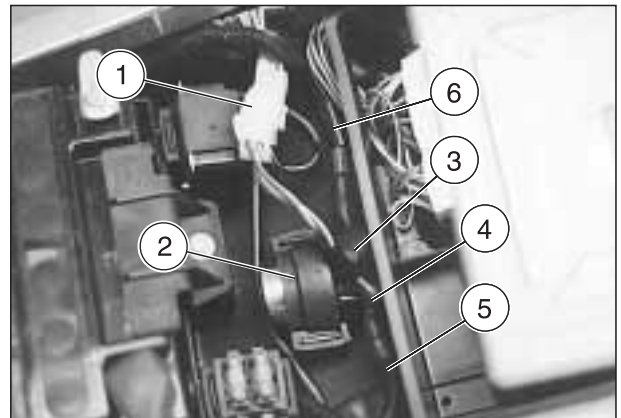

6.6.4 CHECKING THE SIDE STAND AND THE SAFETY SWITCH

The side stand (1) is provided with a safety switch (2) that has the function to prevent or interrupt the operation of the engine with the gears on and the side stand (1) down.

To check the proper functioning of the safety switch (2), proceed as follows:

- ◆ Check the side stand, see 2.41 (CHECKING THE SIDE STAND)
- ◆ Seat on the vehicle in driving position.
- ◆ Fold the side stand (1).
- ◆ Start the engine.
- ◆ With released throttle grip and engine idling, pull the clutch lever completely.
- ◆ Engage the first gear, pushing the gear lever downwards.
- ◆ Lower the side stand (1), thus operating the safety switch (2).

At this point:

- the engine must stop;
- the "side stand down" warning light "SS" must come on.

Should this fail to happen, replace the switch (3).

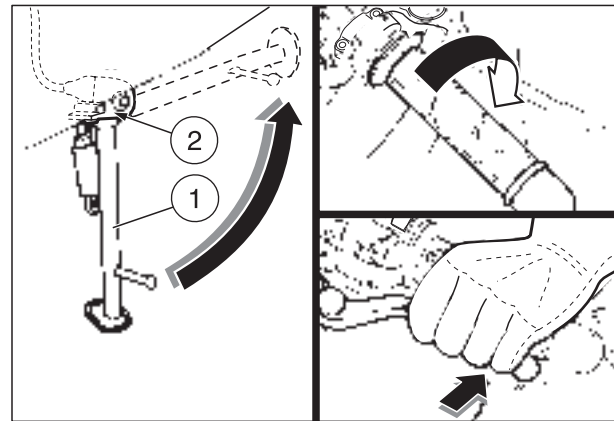
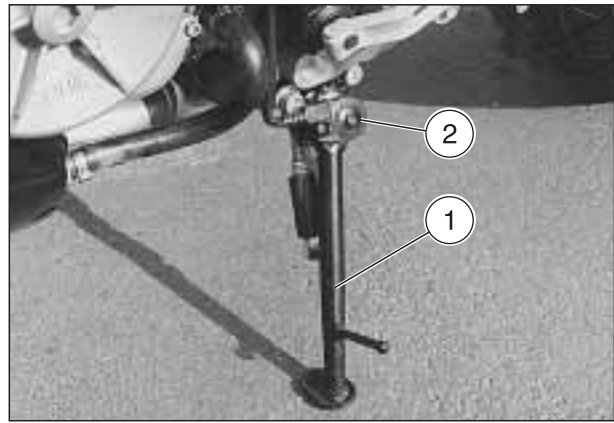

6.6.5 CHECKING THE DIODE MODULE

- ◆ Remove the passenger seat, see 7.1.2 (UNLOCKING/LOCKING THE PASSENGER SEAT).
- ◆ Disconnect the five-way connector (4) (coloured white) from the module (5).

CAUTION

Upon reassembly, make sure that the electric connector (4) is correctly coupled.

- ◆ Power the various terminals at 12 V, placing a 12V - 2W bulb on the positive cable (+), as indicated.

CAUTION

Do not use bulbs over 2W, since the module may be damaged.

-	+	1	2	3	4	5
1			☀	☀	☀	☀
2		●		●	●	●
3		●	●		●	●
4		●	●	●		●
5		●	☀	●	●	

CAUTION

The bulb should only light up in the positions indicated. If this is not the case, replace the module (5).

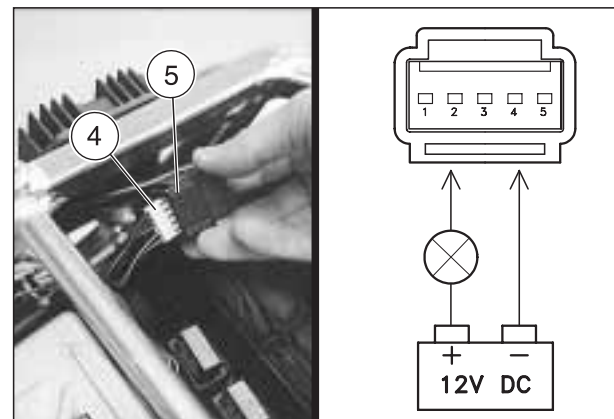
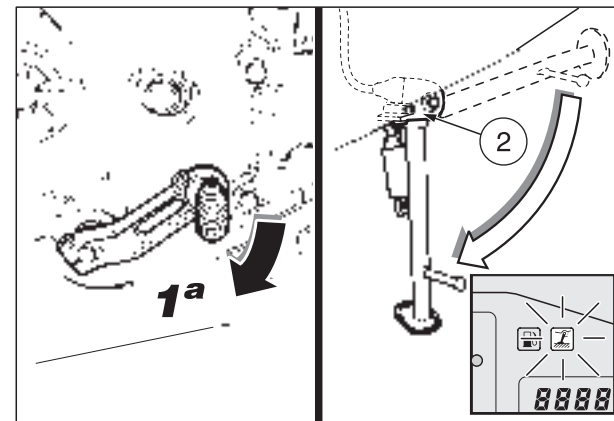

6.7 SWITCHES

Using a tester, check the continuity of the switches, referring to the specific diagram below.
Should any anomalies be encountered, change the corresponding switch set.

6.7.1 SWITCH SET ON RIGHT HANDLEBAR

- 1) Engine stop switch
- 2) Start push button

Pos.	Cables			
	Ar/Gr	V/R	G/R	V/R
⊖			○ — ○	
○	RUN	○ — ○		
	OFF			

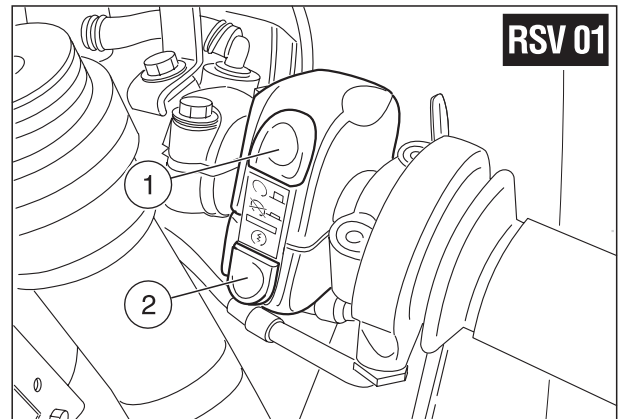
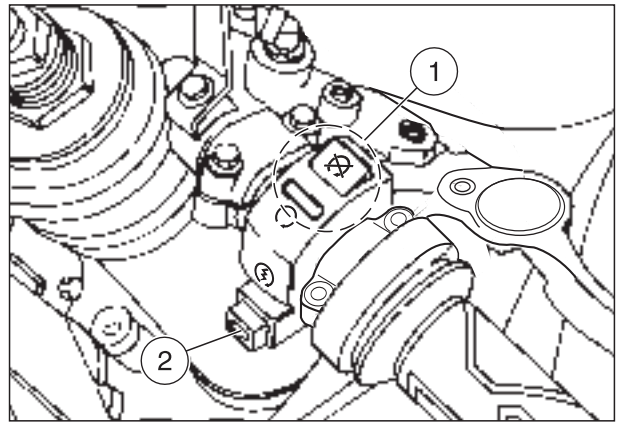

6.7.2 SWITCH SET ON LEFT HANDLEBAR

- 1) Horn push button
- 2) Direction indicator switch
- 3) Dimmer switch
- 4) High beam signaller push button / LAP push button (multifunction)
- 5) Light switch (not provided for ASD)

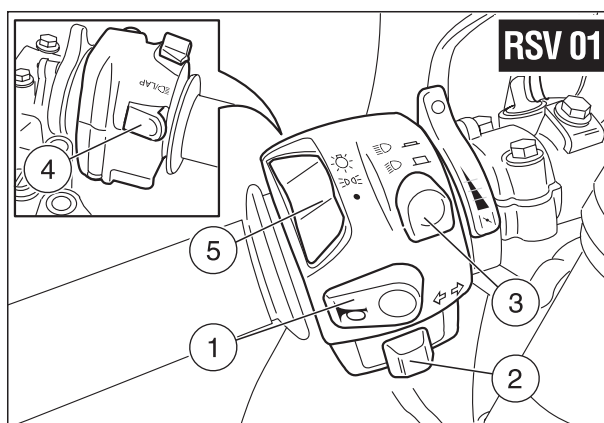
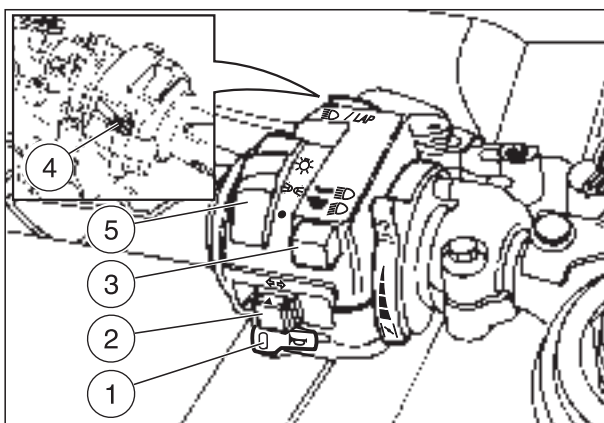

Pos.	Cables									
	Gr	V	G	N	Bi	Bi / B	R	Az	B / N	
☰ / LAP		○				○				
🔔	○	○								
●										
☀️		○	○							
☀️		○	○							○
☀️				○						○
☀️					○					○
↔️							○		○	
↔️								○	○	

ASD

Pos.	Cables									
	Gr	V	G	N	Bi	Bi / B	R	Az	B / N	
☰ / LAP		○				○				
🔔	○	○								
☀️		○	○	○						
☀️		○	○		○					
↔️							○			○
↔️								○	○	

6.7.3 SINGLE SWITCHES

1) Ignition switch

Pos.	Cables			
	R	V/Gr	V	Bi/R
○	○	○	○	○
⊗				
⊔				

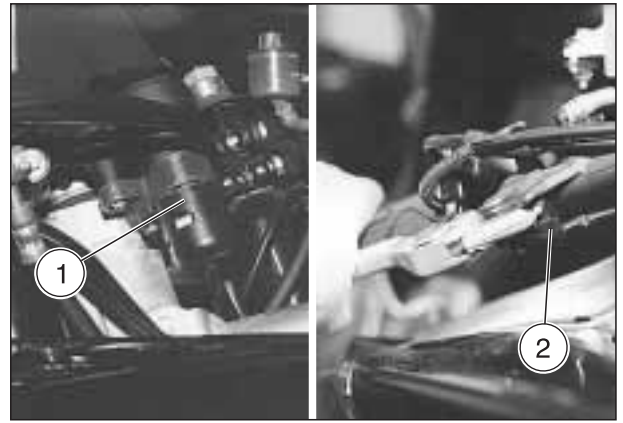

ASD

Pos.	Cables			
	R	V/Gr	V	Bi/R
○	○	○		
⊗			○	○
⊔			○	○

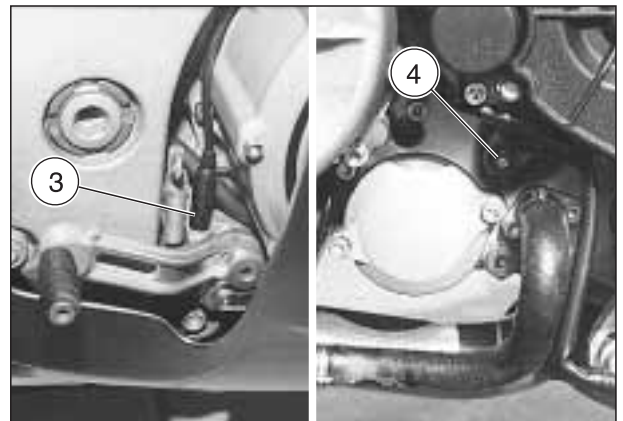

2) Front brake stoplight switch

Pos.	Cables	
	Gr	M
Operating	○	○

3) Rear brake stoplight switch

Pos.	Cables	
	G	G
Operating	○	○

4) Neutral gear switch

Pos.	Cables	
	Screw	⊥
Neutral	○	○

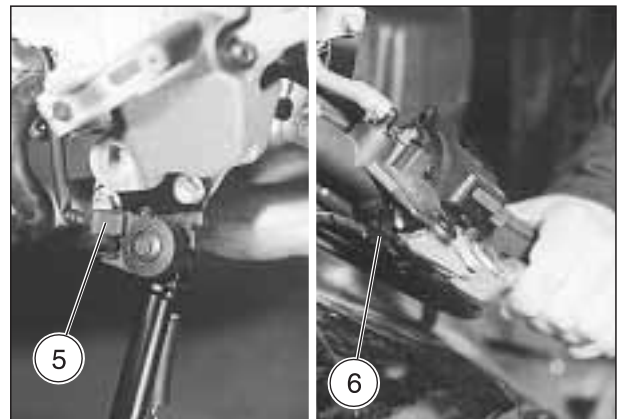

5) Stand switch

Stand	Cables		
	M	V	N
Down	○		○
Up		○	○

6) Clutch lever switch

Pos.	Cables	
	Gr	M
Operating	○	○

6.8 LIGHT SYSTEM

6.8.1 WIRING DIAGRAM

NOTE See 6.2 (ELECTRIC COMPONENTS LAYOUT) for the positioning of the components.

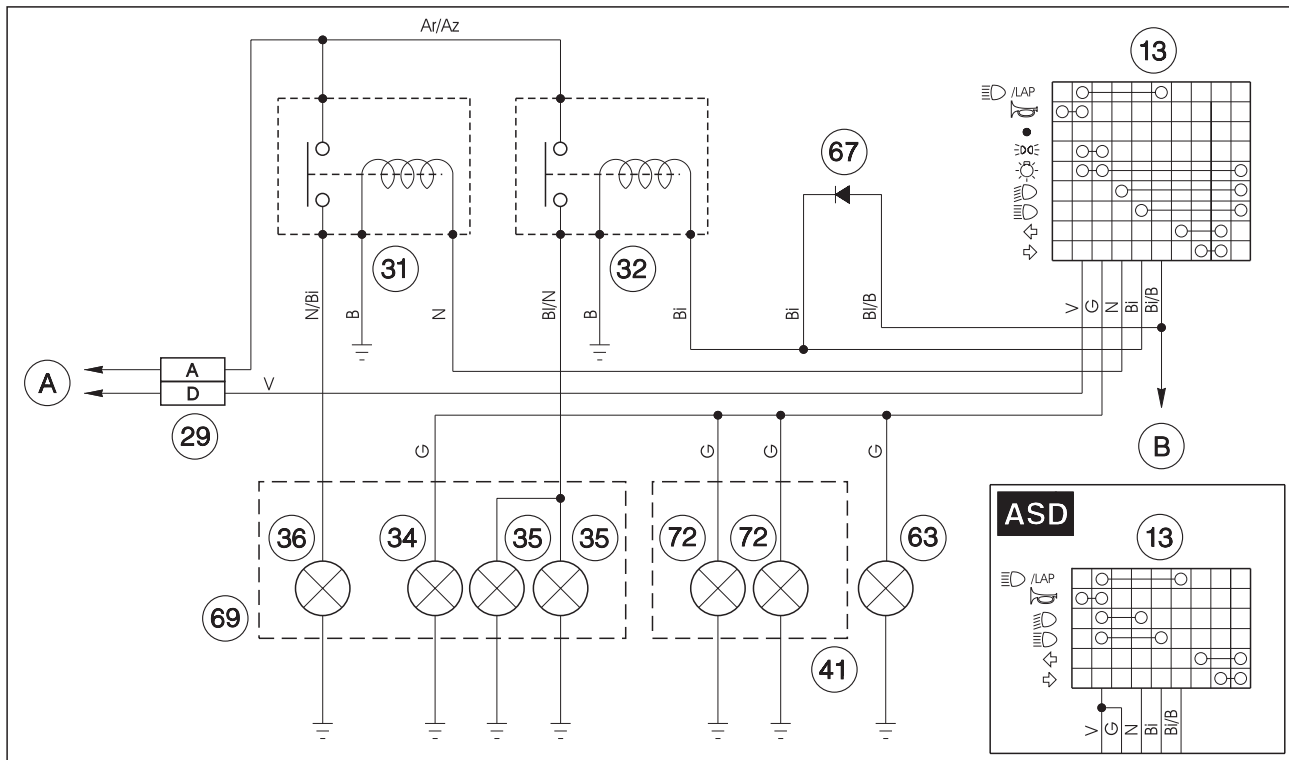

Wiring diagram key

- 13) Left dimmer switch
- 29) Secondary fuses (15 A)
- 31) Low beam relay
- 32) High beam relay
- 34) Front parking light bulb
- 35) High beam bulbs
- 36) Low beam bulb
- 41) Rear light
- 63) Dashboard bulbs
- 67) Dimmer switch diode / LAP (multifunction)
- 69) Headlight
- 72) Rear parking light / stoplight bulbs
- A) To the battery / ignition switch
- B) To the right display / chronometer

6.8.2 CHECKING THE LIGHTS RELAY

In order to check the operation of the relay:

- ◆ Remove the relay box lid located on the left next to the dashboard.
- ◆ Remove the relevant relay (identifiable thanks to the label on the lid):
 - high beam light relay (1);
 - dimmers relay (2).
- ◆ Power the two internal male terminals ("85" – "86") at 12V .
- ◆ Using a tester (acting as ohmmeter), check for breaks between the other two terminals ("87" – "30").

Correct value with relay powered: 0 Ω.

Correct value with relay not powered: ∞ Ω.

If the values do not correspond to those indicated, change the relevant relay.

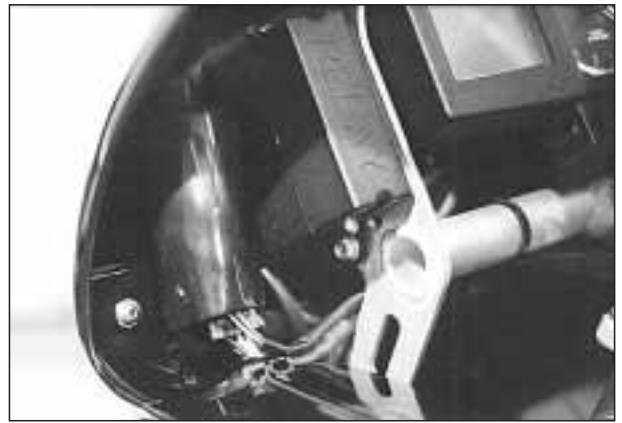

6.8.3 CHECKING THE LIGHTS / LAP DIODE (multifunction)

To check operation of diode:

- ◆ Disconnect the three-way connector (3) (coloured white) (under the rubber protection cap) to the left of the handlebar.

⚠ CAUTION

Upon reassembly, make sure that the electric connector (3) is correctly coupled.

- ◆ Using a tester (in diode test mode), check the values between the two male terminals in the diode, as illustrated in the figure.

Correct value (measurement A): 0 – 1 Ω.

Correct value (measurement B): ∞.

In the event the tester does not feature the diode test mode, power with a voltage of 12 V, placing a 12 V – 2 W bulb on the positive cable and connecting the diode as illustrated in the figure.

⚠ CAUTION

Do not use bulbs over 2 W, since the diode may be damaged.

Test (C): the bulb does not light up.

Test (D): the bulb lights.

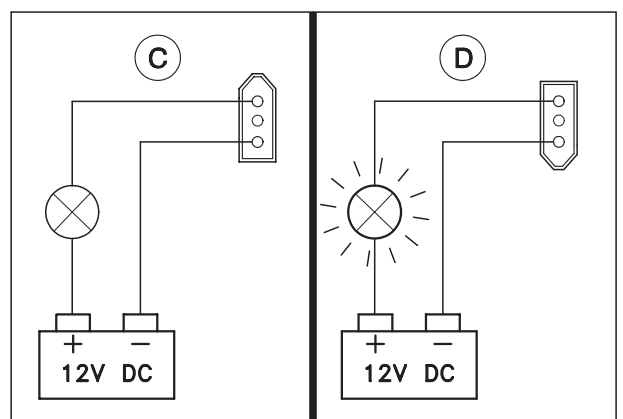
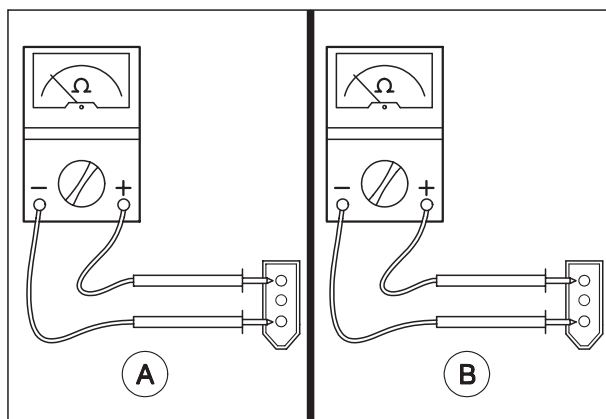
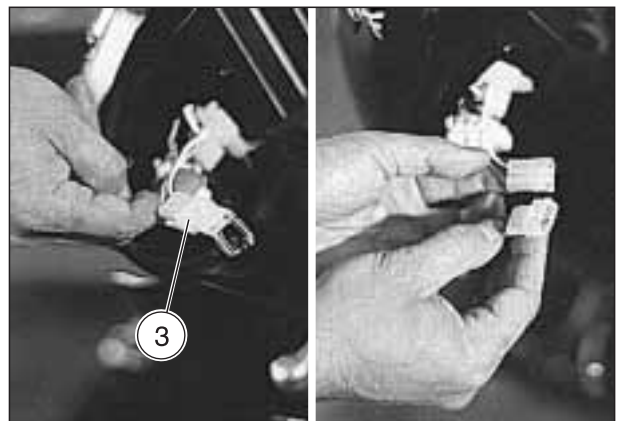
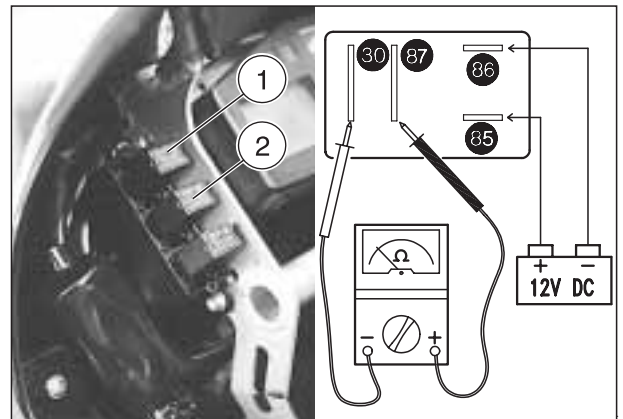

6.9 COOLING ELECTROFAN

6.9.1 WIRING DIAGRAM

NOTE See 6.2 (ELECTRIC COMPONENTS LAYOUT) for the positioning of the components.

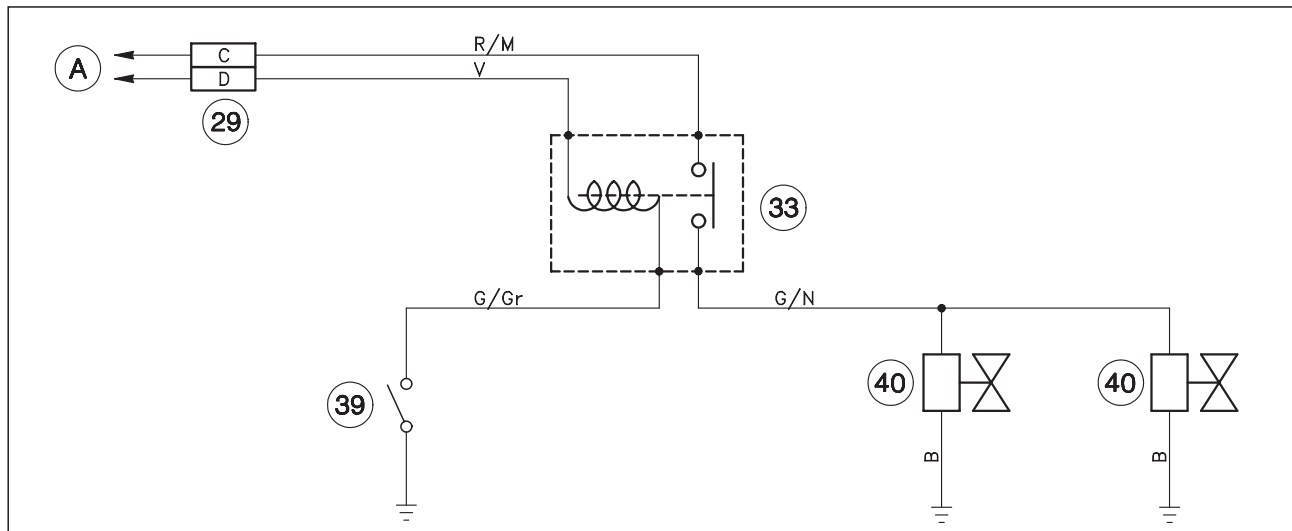

Wiring diagram key

- 29) Secondary fuses (15 A)
- 33) Electric fan relay
- 39) Thermal switch
- 40) Cooling fans
- A) To the battery / ignition switch

6.9.2 CHECKING THE ELECTROFAN OPERATION

NOTE The following procedure refers to a single electrofan, though it is applicable to both.

To check operation of electrofan (1):

- ◆ Remove the left fairing, see 7.1.28 (REMOVING THE SIDE FAIRINGS).
- ◆ Disconnect the two electric terminals (2) (3) from the thermal switch (4) and connect them together.
- ◆ Turn the ignition switch to position "⊗".

⚠ CAUTION

Upon reassembly, make sure that the electric terminals (2) (3) are properly connected.

If the electrofan does not work:

- ◆ Turn the ignition switch to position "⊗".
- ◆ Make sure the connector (5) is correctly inserted.
- ◆ Rotate the fan manually, making sure the blades do not touch the mount.
- ◆ Check the recharging system, see 6.3 (CHECKING THE RECHARGING SYSTEM) and the secondary fuses (15 A).
- ◆ Repeat the procedure for the other electrofan.

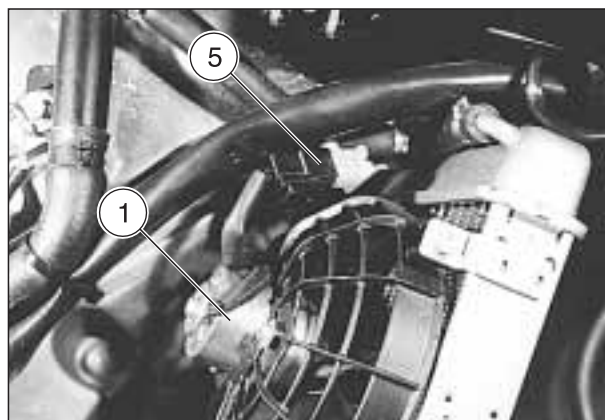
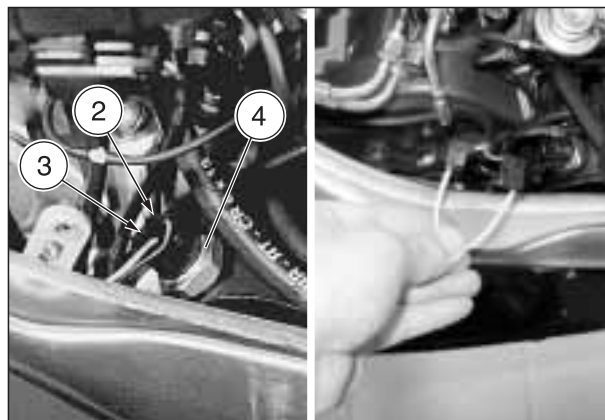

6.9.3 CHECKING THE THERMAL SWITCH OPERATION

Thermal switch	Temperature
switch on	~ 100 °C (212 °F)
switch off	~ 85 °C (185 °F)

NOTE The thermal switch switches to on at a temperature of ~ 100 °C (212 °F) and to off at ~ 85 °C (185 °F); within this range of values, it may switch to on or off indifferently.

- ◆ Remove the thermal switch (1), see 5.4 (REMOVING THE COOLANT THERMAL SWITCH).
- ◆ Connect a tester (2) (set as an ohmmeter) to the thermal switch (1) as illustrated in the figure.
- ◆ Immerse the thermal switch (1) in a container (3) holding coolant.
- ◆ Immerse a thermometer (4) with a 0 – 150 °C (32 – 302 °F) range in the same container.
- ◆ Place the container on a burner (5) and slowly warm up the liquid.
- ◆ Check that the temperature reading on the thermometer (4) and the value indicated by the tester (2) correspond to the data in the table.

Coolant temperature		Standard values (Ω) ($\pm 10\%$)
(°C)	(°F)	
> 100	> 212	0
< 85	< 185	∞

If the values depart excessively from those indicated in the table, change the thermal switch (1).

6.9.4 CHECKING THE ELECTROFAN RELAY

The procedure is the same as that required to check the lights relay, see 6.8.2 (CHECKING THE LIGHTS RELAY).

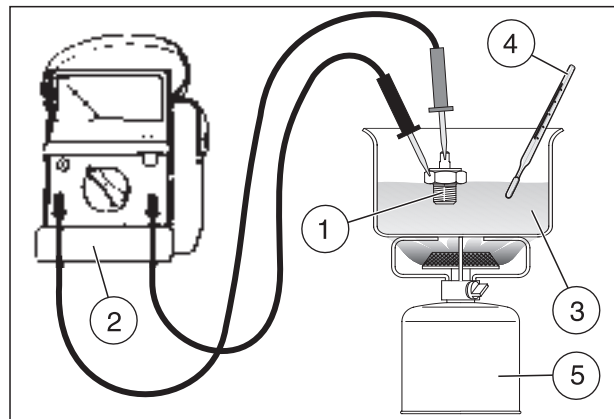
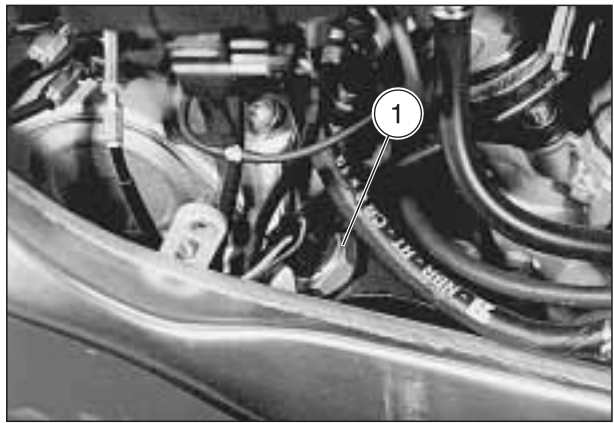

6.10 INDICATORS ON THE DASHBOARD

6.10.1 WIRING DIAGRAM

NOTE See 6.2 (ELECTRIC COMPONENTS LAYOUT) for the positioning of the components.

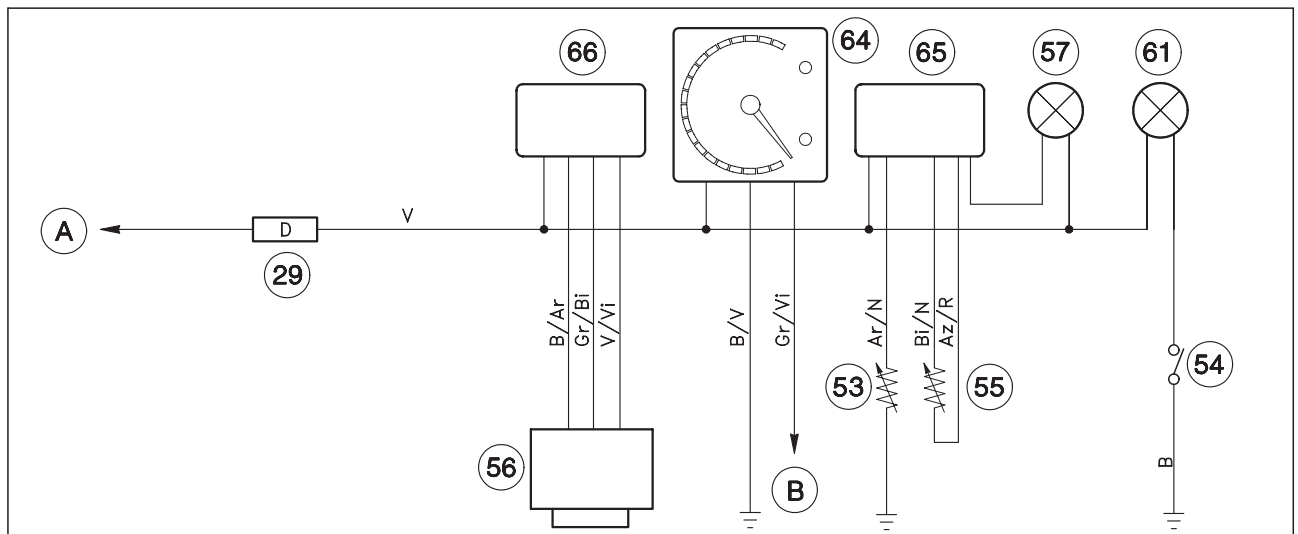

Wiring diagram key

- 29) Secondary fuses (D) (15 A)
- 53) Low fuel sensor
- 54) Engine oil pressure switch
- 55) Coolant temperature thermistor
- 56) Speed sensor
- 57) Low fuel warning light
- 61) Engine oil pressure warning light LED
- 64) Revolution counter
- 65) Multifunction display right side (coolant temperature)
- 66) Multifunction display (left side)
- A) To the ignition switch
- B) To the electronic unit

6.10.2 LOW FUEL WARNING LIGHT

- ◆ Lift the fuel tank, see 2.8 (LIFTING THE FUEL TANK).
- ◆ Disconnect the three-way electric connector (1) (coloured white) of the fuel pump unit.

⚠ CAUTION

Upon reassembly, make sure that the electric connector (1) is correctly coupled.

- ◆ Connect together the orange black (Ar/N) and blue (B) cables from the system side.
- ◆ With the ignition switch (2) set to "O" the "🛢" low fuel warning light should come on after a second.
- ◆ If the "🛢" light does not come on as expected, make sure the sensor (3) is working properly:
- ◆ Fill the tank with petrol.
 - With the sensor (3) fully submersed by petrol: the "🛢" light remains unlit.
- ◆ Drain the fuel tank completely, see 4.2 (DRAINING THE FUEL TANK).
 - With the sensor (3) fully submersed by petrol: the "🛢" light comes on after 30 to 60 seconds.

If these conditions are not achieved, replace the sensor, see 4.4 (REMOVING THE FUEL LEVEL SENSOR).

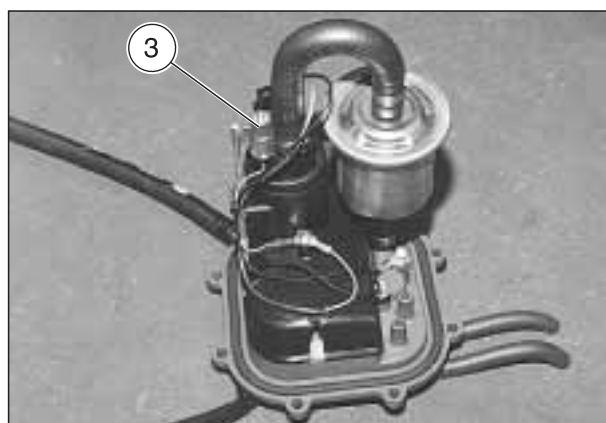
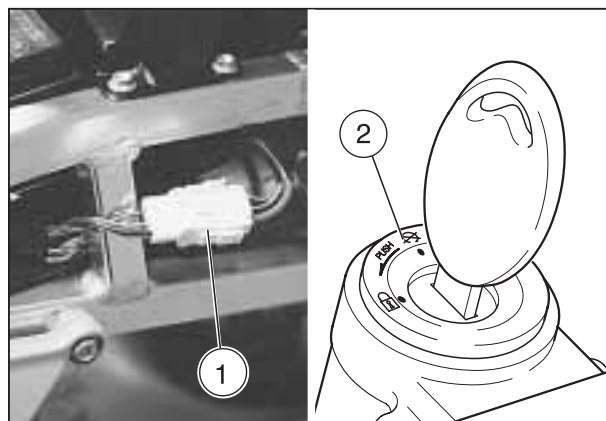

6.10.3 COOLANT TEMPERATURE DISPLAY

NOTE In the event the message “LLL”, appears on the right-hand display, with a temperature below 130 °C (266 °F), there might be a problem with the wiring or the coolant thermistor might have short-circuited (right-hand side of engine, see 6.4.8 (CHECKING THE COOLANT THERMISTOR OPERATION)).

- ◆ Lift the fuel tank, see 2.8 (LIFTING THE FUEL TANK).
- ◆ Disconnect the two-way connector (1) (coloured green) from the thermistor (2) (right-hand side of the engine).

⚠ CAUTION

Upon reassembly, make sure that the electric connector (1) is correctly coupled.

- ◆ Connect the following resistors to the connector (1) and check the message sent up on the right-hand display.

Resistance (Ω)	Message on right display	
	°C (± 10%)	°F (± 10%)
> 1400	<i>c o l d</i>	<i>c o l d</i>
580	60	140
245	90	194
115	120	248
< 90	<i>L L L</i>	<i>L L L</i>

- ◆ If the messages are correct, check the coolant thermistor on the right-hand side of the engine, see 6.4.8 (CHECKING THE COOLANT THERMISTOR OPERATION).

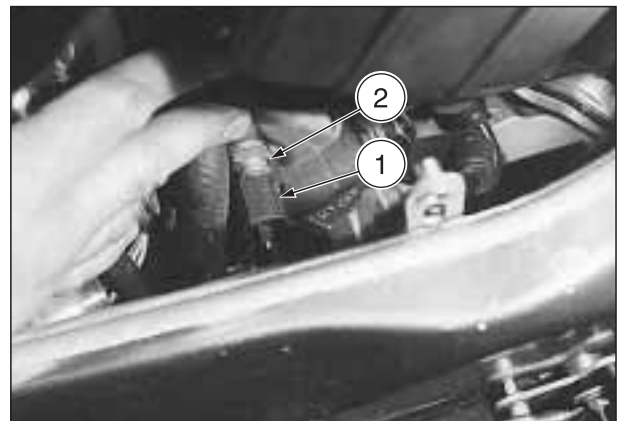
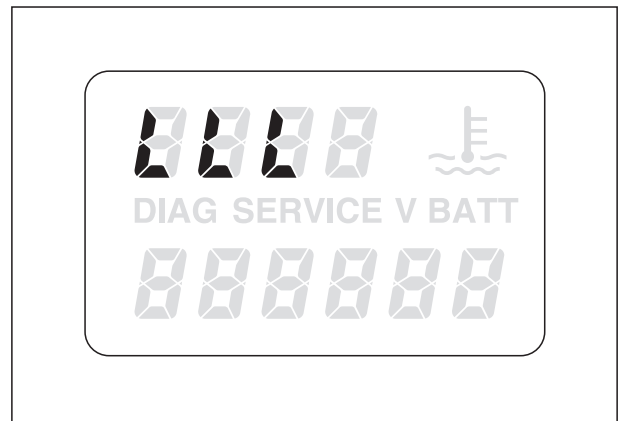



6.10.4 ENGINE OIL PRESSURE SENSOR

- ◆ Remove the lower fairing, see 7.1.34 (REMOVING THE LOWER FAIRING).
- ◆ Slip off the rubber protection (3).
- ◆ Disconnect the electric terminal (4) from the sensor (5) and earth it.

⚠ CAUTION

When reassembling, make sure the electric terminal (4) is connected properly.

- ◆ With the ignition switch set to “O”, the red low engine oil pressure “” LED should come on.
- ◆ If the “” LED comes on as expected, check the sensor is working properly.
- ◆ With a tester (scale x 100 Ω) check for breaks between the tongued terminal (6) and the casing of the sensor (5) (see figure).

Correct value with engine off: 0 Ω.

Correct value with engine running: ∞ Ω.

If the values do not correspond to those indicated, check that the engine oil level is correct, see 2.13 (CHECKING THE ENGINE OIL LEVEL AND TOPPING UP) and change the sensor (5), if necessary.

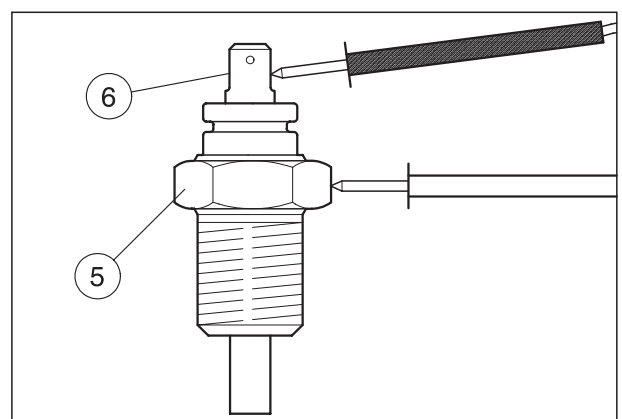
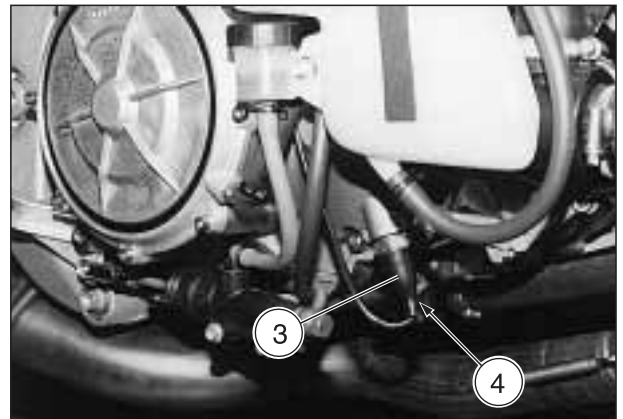

6.10.5 SPEEDOMETER

- ◆ Remove the right panel, see 7.1.3 (REMOVING THE SIDE COVERS).
- ◆ Make sure that the coupling of the speed sensor connector (1) is correct.
- ◆ Remove the front part of the fairing, see 7.1.22 (REMOVING THE FRONT PART OF THE FAIRING).
- ◆ Make sure that the coupling of the dashboard connector (2) is correct.
- ◆ Check the distance between the speed sensor (3) and the five screws (4) securing the rear brake disc.

Distance between sensor (3) and screws (4): 1.5 ± 1 mm.

- ◆ Make sure all five screws are present (4).

With the engine off and the ignition switch set to "O", perform the following tests:

Test 1st

- ◆ Without disconnecting the electric connectors (1) (2) and working on the speed sensor connector (1), use a tester to measure the voltage between the green/violet (V/Vi) and blue/orange (B/Ar) cables.

Correct value: > 9 V (c.c.).

Test 2nd

- ◆ Without disconnecting the electric connectors (1) (2) and working on the speed sensor connector (1), use a tester to measure the voltage between the grey/white (Gr/Bi) and blue/orange (B/Ar) cables.

Correct value: > 6 V (c.c.).

Test 3rd

- ◆ Position the vehicle on the appropriate rear support stand, see 1.8.2 (POSITIONING THE VEHICLE ON THE REAR SUPPORT STAND **OPT**).
- ◆ Position the gear lever in neutral.
- ◆ Perform test 2nd.
- ◆ Spin the rear wheel by hand until one of the five screws (4) is in line with the sensor (3). The tester should read **zero V** for approx. two seconds before returning to > 6 V.
- If test 1st gives an incorrect result, disconnect the speed sensor (3) and repeat test 1st; If the wrong value persists, the dashboard is faulty and must be replaced with one in perfect condition.
- If test 1st gives a correct result and test 2nd an incorrect value, the speed sensor (3) is faulty and must be replaced.
- If both tests 1st and 2nd give a correct result and test 3rd an incorrect value, the speed sensor (3) is faulty and must be replaced.
- If all three tests give a correct result and no speed comes up on the left-hand display, the dashboard is faulty and must be replaced with one in perfect condition.

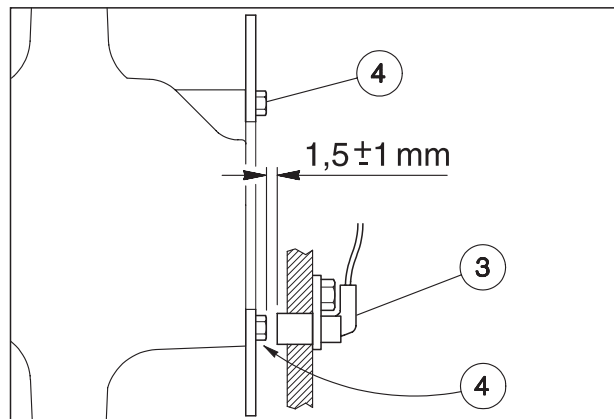
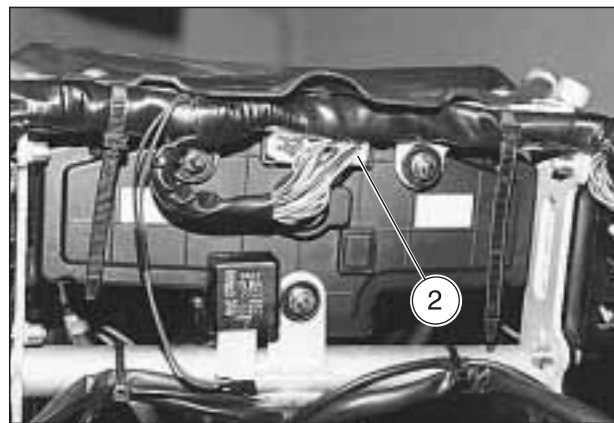
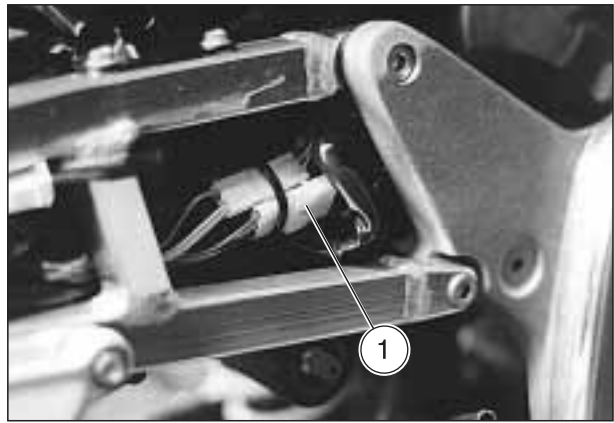

6.10.6 REVOLUTION COUNTER

- ◆ Remove the front part of the fairing, see 7.1.22 (REMOVING THE FRONT PART OF THE FAIRING).
- ◆ Turn the ignition switch to position "O".

NOTE Without disconnecting the dashboard connector (1).

- ◆ By means of a tester check, on the dashboard connector side, if there is voltage between the green (V) and blue/green (B/V) power supply cables of the revolution counter;

MEASUREMENT (A)

Correct value: 12 – 15 V.

- ◆ Put back the rider saddle, see 7.1.1 (REMOVING THE RIDER SADDLE).
- ◆ Remove the upper protection element (3).

NOTE Without disconnecting the dashboard connector (1) and the 26-way connector (2) of the electronic unit.

- ◆ Working on the dashboard connector (1) and on the 26-way connector (2) of the electronic unit, measure the continuity of the grey/violet (Gr / Vi) cable - measure (B) - with an ohmmeter-tester.

If the result is positive:

- ◆ Disconnect the dashboard connector (1) and connect a dashboard that is certainly working correctly.
- ◆ If the rev counter still does not work even after the dashboard is replaced, the fault is to be found in the electronic unit.

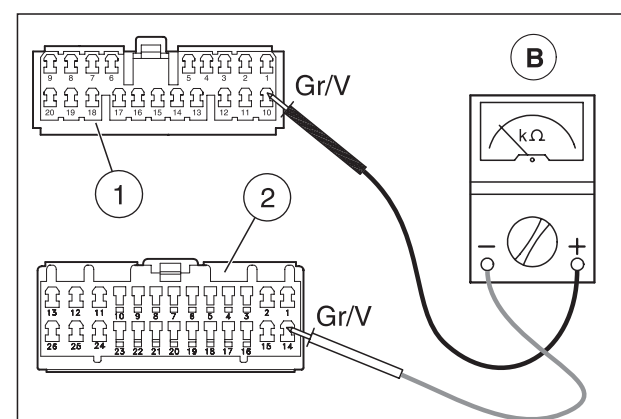
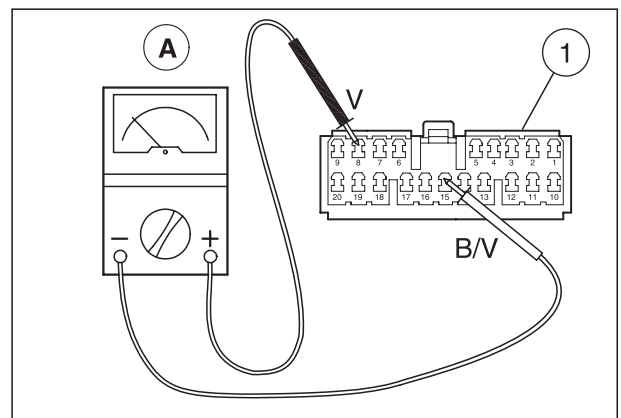
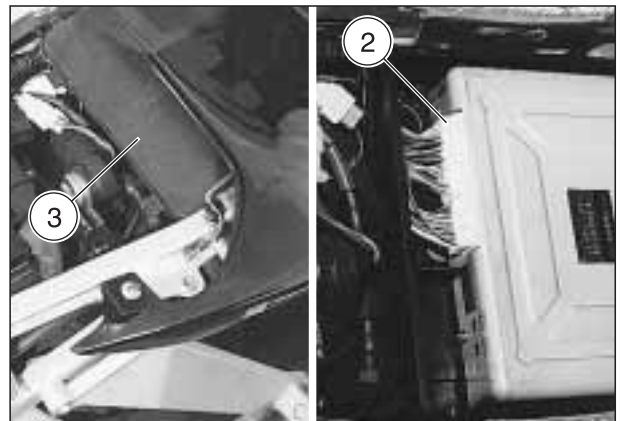
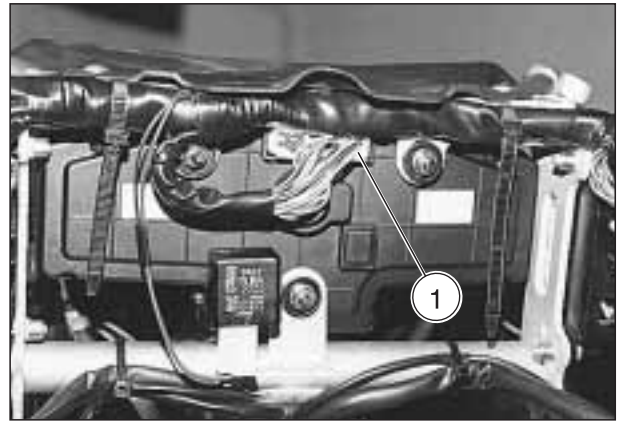

6.11 BATTERY

NOTE This vehicle is provided with a maintenance-free battery and no operation is necessary, excepting occasional checks and the recharge when required.

When changing batteries, replace with a battery of the same type, see 1.5 (TECHNICAL SPECIFICATIONS)

Carefully read 2.4 (BATTERY).

6.11.1 ACTIVATING THE BATTERY

- ◆ Remove the battery, see 7.1.8 (REMOVING THE BATTERY).

⚠ WARNING

The electrolyte in the battery is toxic and caustic and may cause burns on contact with the skin as it contains sulphuric acid.

Wear protective clothing, a face mask and/or goggles during service operations.

In case of contact with the skin, rinse with plenty of water.

In case of contact with the eyes, wash with large quantities of water for fifteen minutes and consult an oculist without delay.

If the liquid is accidentally swallowed, drink large amounts of water or milk, then continue drinking milk of magnesia or vegetable oil and promptly call a doctor.

The battery gives off explosive gases; keep it away from flames, sparks, cigarettes and any other source of heat.

During the recharging or the use, make sure that the room is properly ventilated and avoid inhaling the gases released during the recharging.

KEEP AWAY FROM CHILDREN.

The battery fluid which is very corrosive.

Do not pour or spill it, especially on the plastic parts.

⚠ CAUTION

Make sure the electrolyte liquid is specific for the battery to be activated.

- ◆ Place the battery on a flat surface.
- ◆ Remove the adhesive sealing label (1).
- ◆ Remove the sealed bag from the cardboard container containing the relevant six reservoirs (2).
- ◆ Take the reservoirs (2) out of the bag.

NOTE Keep the row of stoppers (3) handy as you will need them later to plug the battery cells.

- ◆ Disconnect the row of stoppers (3) from the top of the reservoirs (2).

⚠ CAUTION

Do not cut or make holes in the sealed parts on the reservoirs (2).

Follow ►



Follow ►

- ◆ Turn the reservoirs (2) upside down and place them so that the sealed parts are over the openings of the battery cells.
- ◆ Press on the reservoirs (2) so that the seals break and the acid is allowed to pour into the battery cells.

NOTE Make sure the reservoirs (2) are positioned above the battery as vertically as possible to enable the liquid to flow out.

- ◆ Leave the reservoirs (2) in place on the battery for approx. twenty minutes, checking the liquid flows out properly.

⚠ CAUTION

Do not remove the reservoirs (2) from the battery until all the liquid has poured out.

- ◆ Should any liquid still be left in the reservoirs (2) once the twenty minutes are up, tap your fingers on the top of the reservoirs to help the remaining liquid out.
- ◆ Lift the reservoirs (2) with care, disengaging them from the battery.
- ◆ Place the row of stoppers (3) over the battery cell openings.
- ◆ Press down firmly until the tops of the stoppers (3) are flush with the top of the battery.

⚠ CAUTION

The row of stoppers (3) must NEVER be removed.

- ◆ Connect the battery to a battery charger.
- ◆ Subject the battery to a normal charge cycle see 2.4.2 (RECHARGING THE BATTERY).
- ◆ Refit the battery on the vehicle on being returned to the customer.

6.11.2 BATTERY MAINTENANCE

- ◆ If the vehicle remains unused for more than fifteen days, the battery must be recharged to prevent sulphation, recharge the battery using a normal charge, see 2.4.2 (RECHARGING THE BATTERY).
- ◆ Smear a film of neutral grease or vaseline on the terminals.

6.11.3 CHECKING THE BATTERY

Should any anomalies be encountered, first check the recharging circuit, making sure that it is working correctly, see 6.3 (CHECKING THE RECHARGING SYSTEM).

In addition, make sure that:

- ◆ There are no signs of damage (external case cracked) and no electrolyte leak.
- ◆ The terminals are securely fastened to the clamps.
- ◆ Proceed with the normal charge for at least 10 hours, see 2.4.2 (RECHARGING THE BATTERY).

⚠ CAUTION

After recharging, check the no-load voltage; if it is lower than 12 V, it is absolutely necessary to change the battery.

6.11.4 RETURN UNDER GUARANTEE BATTERY

The guarantee is not valid if the battery features:

- ◆ Damage (dented box, bent poles, etc.).
- ◆ Widespread sulphation (incorrect activation and/or use of the battery).

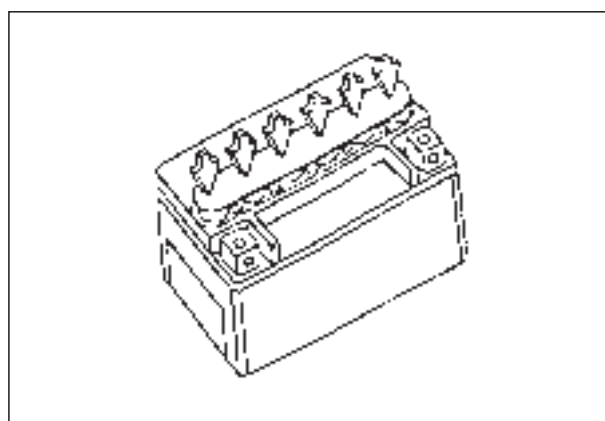
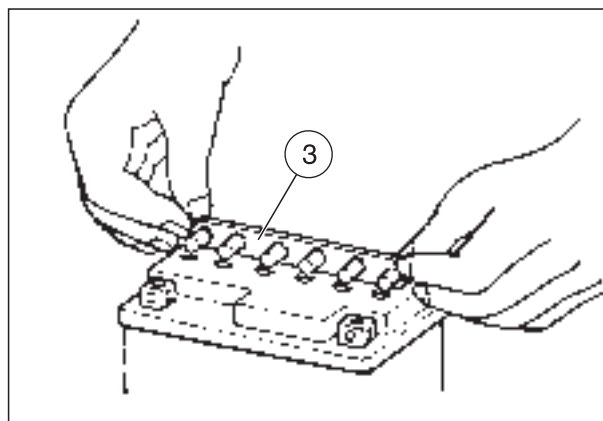
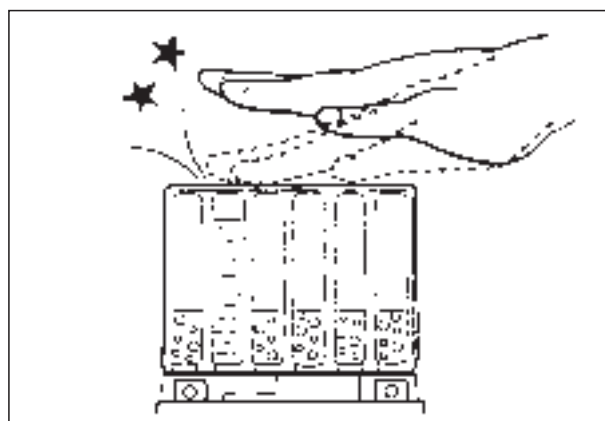
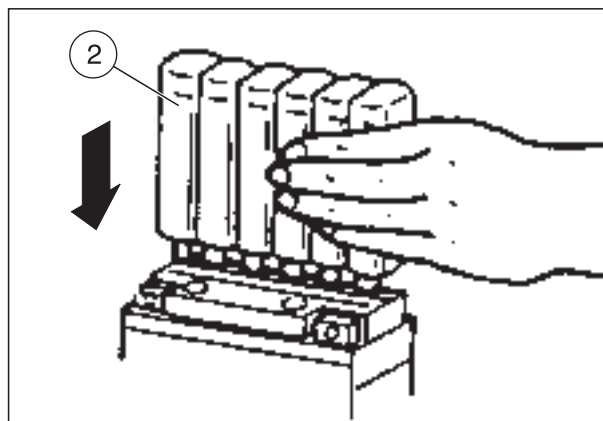

6.12 CHANGING THE BULBS

Carefully read 0.5.1 (PRECAUTIONS AND GENERAL INFORMATIONS).

⚠ WARNING

Risk of fire.

Keep fuel and other flammable substances away from the electrical components.

⚠ CAUTION

Before changing a bulb, move the ignition switch to position "⊗" and wait a few minutes, so that the bulb cools down.

Change the bulb wearing clean gloves or using a clean and dry cloth.

Do not leave fingerprints on the bulb, since these may cause its overheating and consequent breakage. If you touch the bulb with bare hands, remove any fingerprint with alcohol, in order to avoid any damage.

DO NOT FORCE THE ELECTRIC CABLES.

NOTE Before changing a bulb, check the fuses, see 6.15 (CHANGING THE FUSES).

6.12.1 CHANGING THE HEADLIGHT BULBS

◆ Position the vehicle on the stand.

NOTE Before changing a bulb, check the fuses, see 6.15 (CHANGING THE FUSES).

The headlight contains:

- two high beam bulbs (1) (side);
- one parking light bulb (2) (upper);
- one low beam bulb (3) (lower).

RSV 01 The high beam and the low beam bulbs are equal to each other.

NOTE The removal of the front part of the fairing is necessary when the parking light bulb and the high beam bulbs must be changed.

To change, proceed as follows:

PARKING LIGHT BULB

◆ Remove the front part of the fairing, see 7.1.22 (REMOVING THE FRONT PART OF THE FAIRING).

⚠ CAUTION

To extract the bulb socket, do not pull the electric wires.

- ◆ Grasp the parking light bulb socket (4), pull it and remove it from its seat.
- ◆ Withdraw the bulb (2) and replace it with one of the same type.

NOTE Make sure that the bulb is correctly inserted in the bulb socket.

Follow ►

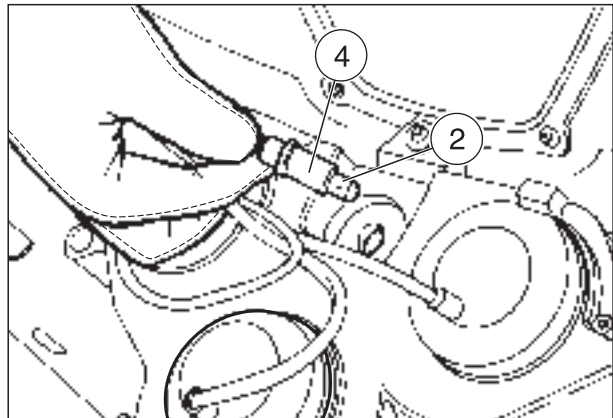
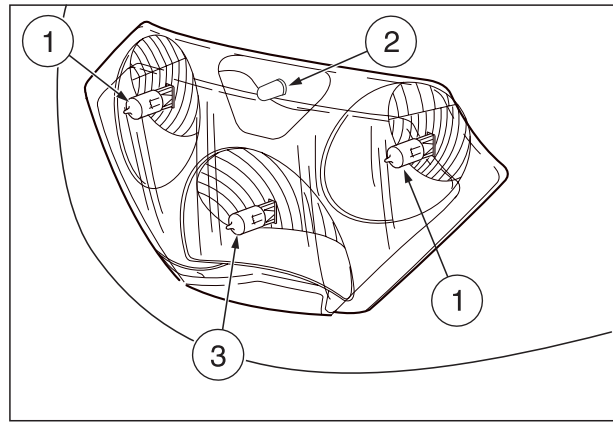

RSV mille

Follow ►

HIGH BEAM BULBS

- ◆ Remove the front part of the fairing, see 7.1.22 (REMOVING THE FRONT PART OF THE FAIRING).
- ◆ Move the protection element (5) of the bulb to be changed with your hands.
- ◆ Withdraw the electric terminal (6).
- ◆ Release the check spring (7) positioned at the rear of the bulb socket (8).
- ◆ Extract the bulb (1) from its seat and replace it with a new one of the same type.

RSV 01 HIGH BEAM BULBS

NOTE Extract the connectors one by one, in such a way as to avoid positioning them wrongly upon reassembly.

If it is necessary to remove all the connectors at the same time, mark them and make sure that you position them correctly upon reassembly.

- ◆ Remove the front part of the fairing, see 7.1.22 (REMOVING THE FRONT PART OF THE FAIRING).
- ◆ Move the protection element (5) of the bulb to be changed with your hands.

⚠ CAUTION

To extract the bulb electric connector, do not pull its wires.

- ◆ Grasp the bulb electric connector (9), pull it and disconnect it from the bulb.
- ◆ Release the two ends of the check spring (7) positioned on the bulb socket (8).
- ◆ Extract the bulb from its seat.

NOTE Insert the bulb in the bulb socket, making the respective positioning seats (A) coincide.

- ◆ Correctly install a new bulb of the same type.

Upon reassembly:

NOTE Put back the protection element (4) with the cable passage facing downwards.

NOTE Insert the bulb in the bulb socket, making the relevant positioning seats coincide.

Follow ►

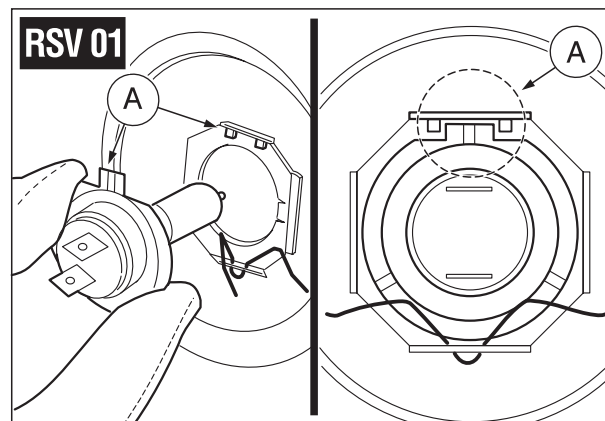
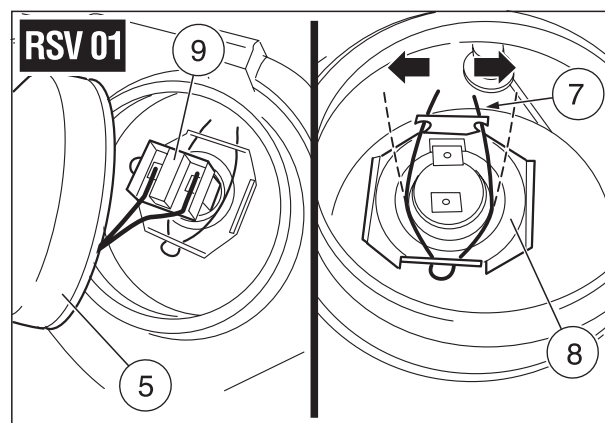
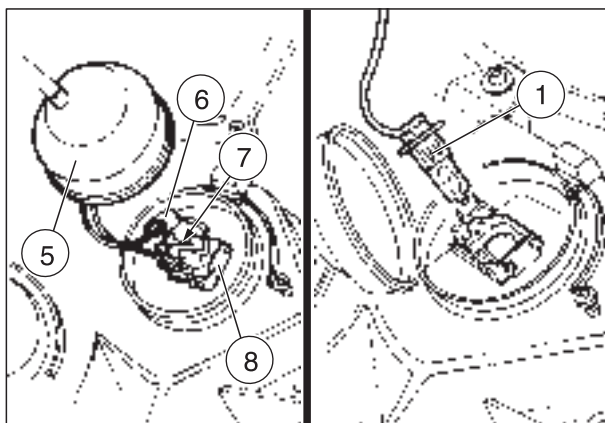

Follow ►

LOW BEAM BULB

- ◆ Move the protection element (10) with your hands.
- ◆ Withdraw the bulb electric connector (11).
- ◆ Rotate the bulb socket (12) anticlockwise and extract it from its seat.
- ◆ Extract the bulb (3) from its seat and replace it with a new one of the same type.

NOTE Insert the bulb in the bulb socket, making the relevant positioning seats coincide.

RSV 01 LOW BEAM BULB

NOTE Extract the connectors one by one, in such a way as to avoid positioning them wrongly upon reassembly.

If it is necessary to remove all the connectors at the same time, mark them and make sure that you position them correctly upon reassembly.

- ◆ Remove the front part of the fairing, see 7.1.22 (REMOVING THE FRONT PART OF THE FAIRING).
- ◆ Move the protection element (10) with your hands.

CAUTION

To extract the bulb electric connector, do not pull its wires.

- ◆ Grasp the bulb electric connector (11), pull it and disconnect it from the bulb.
- ◆ Release the two ends of the check spring (13) positioned on the bulb socket (12).
- ◆ Extract the bulb from its seat.

NOTE Insert the bulb in the bulb socket, making the respective positioning seats (A) coincide.

- ◆ Correctly install a new bulb of the same type.

Upon reassembly:

NOTE Put back the protection element (10) with the cable passage facing downwards.

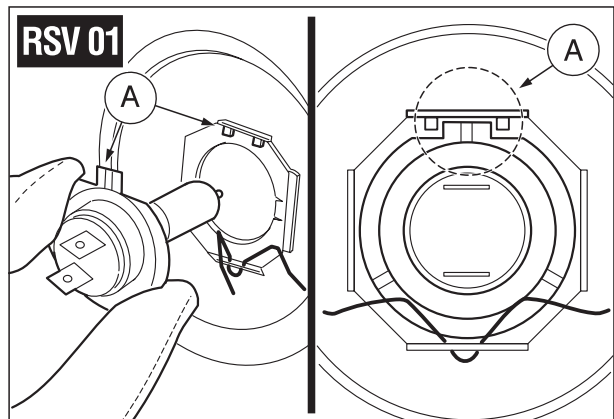
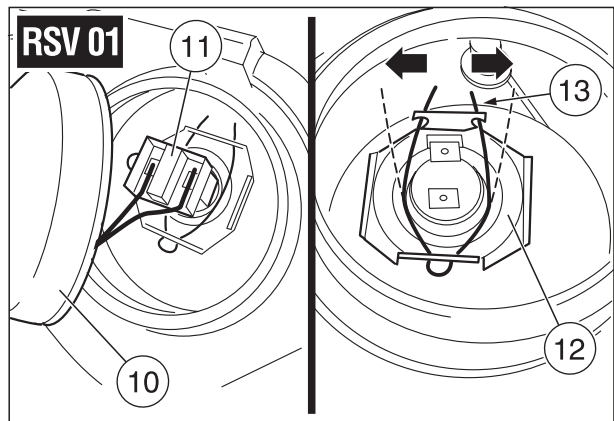
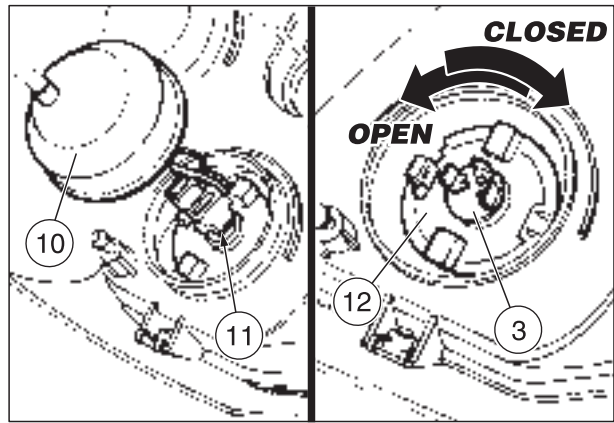

6.12.2 CHANGING THE FRONT AND REAR DIRECTION INDICATOR BULBS

- ◆ Position the vehicle on the stand.

NOTE Before changing a bulb, check the fuses, see 6.15 (CHANGING THE FUSES).

- ◆ Unscrew and remove the screw (1).

⚠ CAUTION

While removing the protection screen, proceed carefully in order not to break the cog.

- ◆ Remove the protection screen (2).

⚠ CAUTION

Upon reassembly, correctly position the protection screen in its seat.

Tighten the screw (1) moderately and carefully, to avoid damaging the protection screen.

- ◆ Press the bulb (3) slightly and rotate it anticlockwise.
- ◆ Extract the bulb (3) from its seat.

NOTE Insert the bulb in the bulb socket, making the two bulb pins coincide with the relevant guides on the socket.

- ◆ Correctly install a new bulb of the same type.

NOTE If the bulb socket (4) goes out of its seat, insert it correctly, making the bulb socket opening coincide with the screw seat.

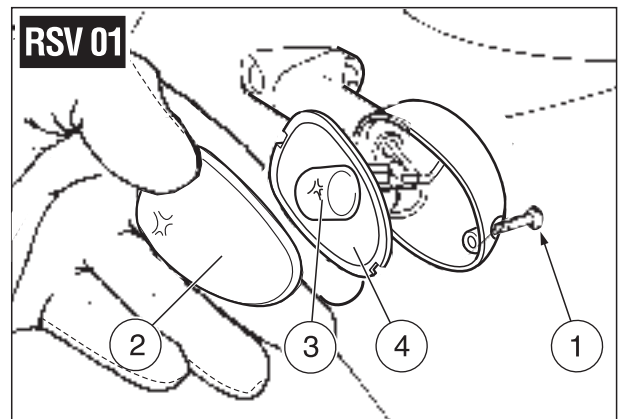
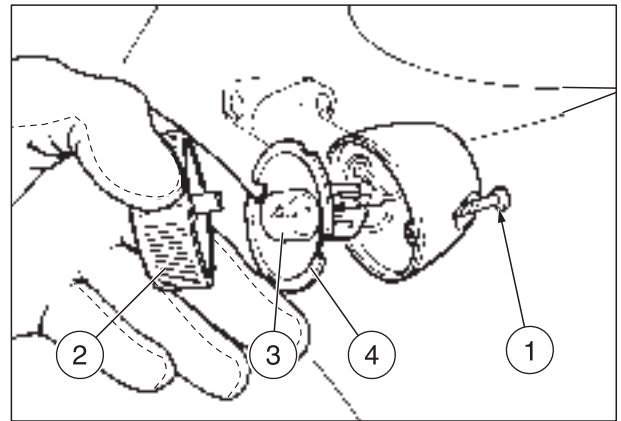

6.12.3 CHANGING THE REAR LIGHT BULB

NOTE The rear light houses two parking light/stoptlight bulbs (5).

The following operations refer to a single bulb, but are valid for both.

- ◆ Position the vehicle on the stand.

NOTE Before changing a bulb, check the fuses, see 6.15 (CHANGING THE FUSES) and the efficiency of the stoplight switches, see 6.16 (CHECKING THE SWITCHES).

- ◆ Unscrew and remove the two screws (6).
- ◆ Remove the protection screen (7).

⚠ CAUTION

Upon reassembly, correctly position the protection screen in its seat.

Tighten the screw (6) carefully, without exerting too much pressure, in order to avoid damaging the protection screen.

- ◆ Press the bulb (8) slightly and rotate it anticlockwise.
- ◆ Extract the bulb (8) from its seat.

NOTE Insert the bulb in the bulb socket, making the two bulb pins coincide with the relevant guides on the socket.

- ◆ Correctly install a new bulb of the same type.

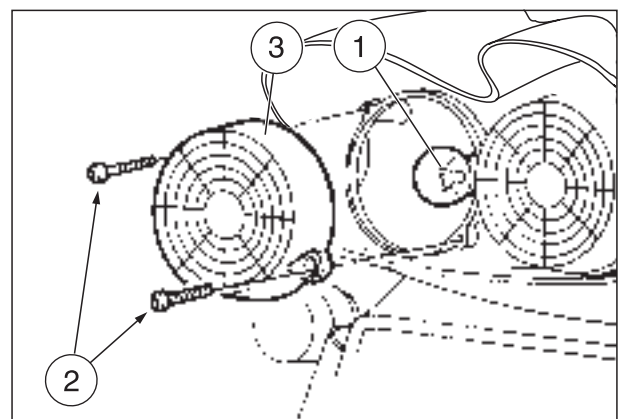
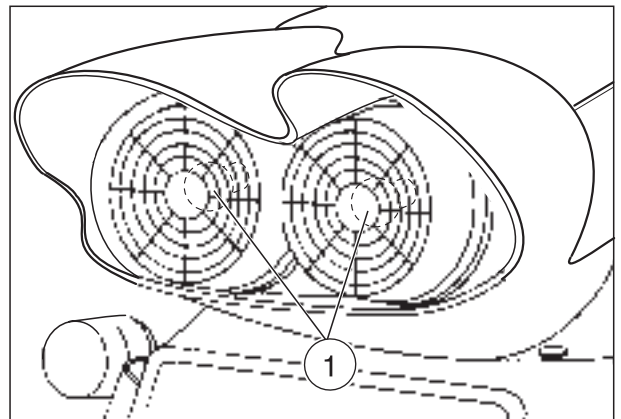





6.12.4 CHANGING THE DASHBOARD BULBS / LIGHTS

NOTE Before replacing a bulb/light, check the fuses, see 6.15 (CHANGING THE FUSES).

To change, proceed as follows:

- ◆ Remove the dashboard, see 7.1.25 (REMOVING THE DASHBOARD).
- ◆ Unscrew and remove the eight fastening screws (1).
- ◆ Remove the rear cover (2).
- ◆ Slide out the relevant bulb holder and, where necessary, replace the bulb:

Pos.	Description
3	Bulbs for right-hand display lighting
4	Bulbs for left-hand display lighting
5	Bulbs for rev counter lighting

Pos.	Warn- ing light	Description
6		Side stand down
7		fuel reserve
8		High beam
9		direction indicators
10		neutral

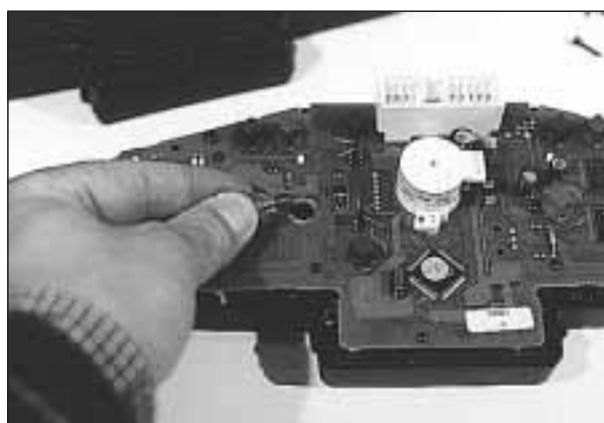
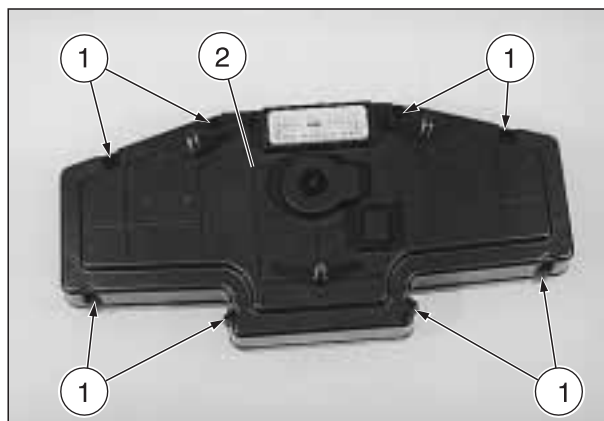

CAUTION

If the defect persists even after the bulb/light has been changed, check the relevant sensor/switch, see:

- 6.6.4 (CHECKING THE SIDE STAND AND THE SAFETY SWITCH);
- 6.10.2 (LOW FUEL WARNING LIGHT);
- 6.10.4 (ENGINE OIL PRESSURE SENSOR).

NOTE The two LEDs (11) and (12) cannot be removed.

Pos.	LED	Description
11		engine oil pressure
12	<i>max</i>	red line

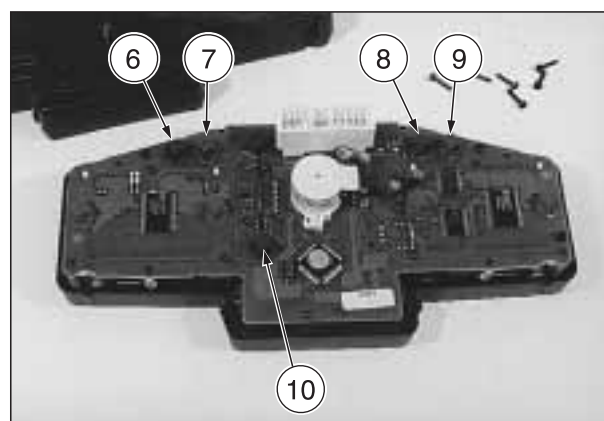
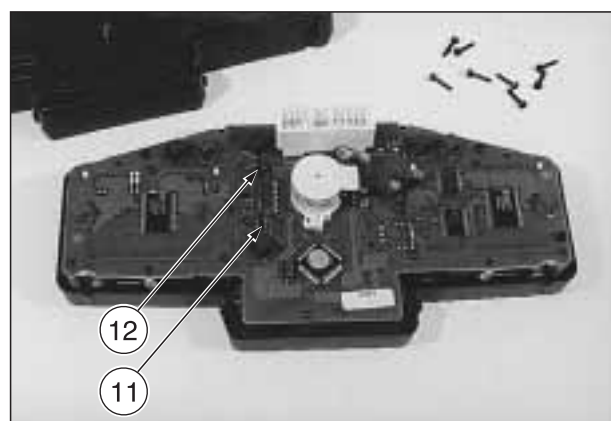
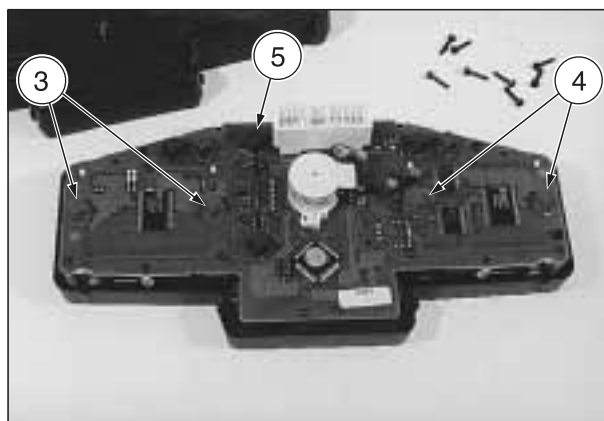

6.13 ADJUSTING THE VERTICAL HEADLIGHT BEAM

NOTE To check the direction of the headlight beam, specific procedures must be adopted, in accordance with the regulations in force in the country where the vehicle is used.

1

To rapidly check the correct direction of the beam, place the vehicle on flat ground, 10 m away from a wall.

Turn on the low beam, sit on the vehicle and make sure that the beam projected on the wall is slightly under the horizontal line of the headlight (about 9/10th of the total height).

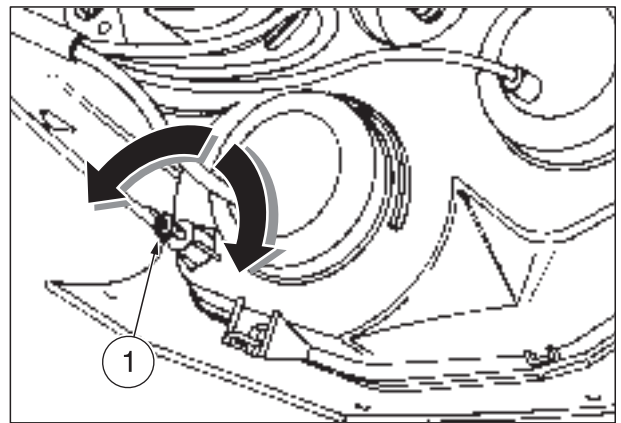

To adjust the headlight beam:

◆ Working on the rear left side of the front part of the fairing, adjust the appropriate screw (1) by means of a short cross-tip screwdriver.

- By **SCREWING IT** (clockwise), you set the beam upwards.
- By **UNSCREWING IT** (anticlockwise), you set the beam downwards.

After the adjustment:

⚠ WARNING

Make sure that the vertical adjustment of the headlight beam is correct.

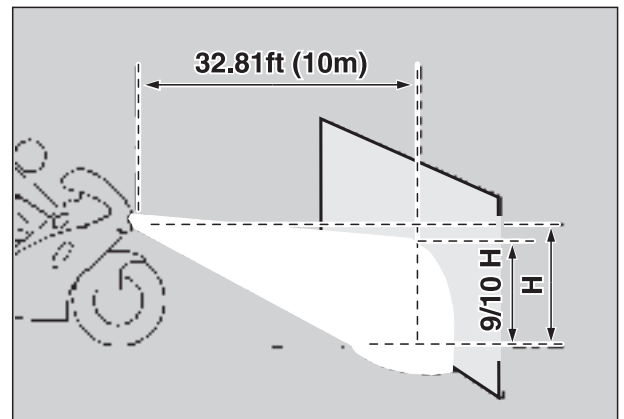

6.14 ADJUSTING THE HORIZONTAL HEADLIGHT BEAM ^{USA}

NOTE To check the direction of the headlight beam, specific procedures must be adopted, in accordance with the regulations in force in the country where the vehicle is used.

NOTE Before proceeding with the horizontal adjustment of the high beam, the vertical adjustment of the headlight beam must be performed, see 6.13 (ADJUSTING THE VERTICAL HEADLIGHT BEAM).

◆ Working from the right-hand side of the vehicle, adjust the relevant screw (2) by means of a short Phillips screwdriver.

- By **SCREWING IT** (clockwise) moves the beam to the left.
- By **UNSCREWING IT** (anticlockwise) moves the beam to the right.

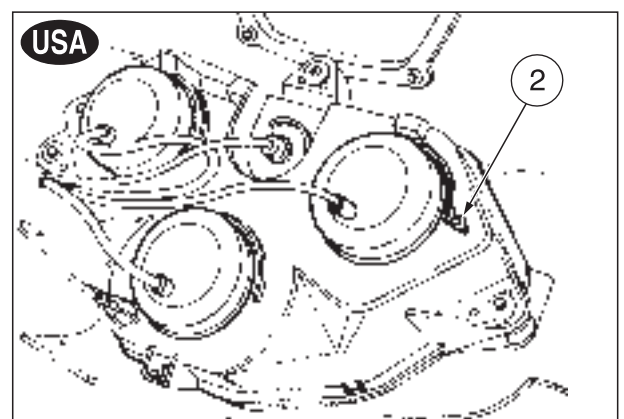
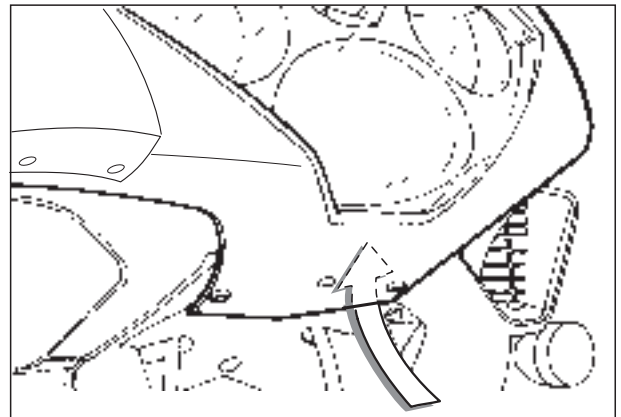

6.15 CHANGING THE FUSES

Carefully read 0.5.1 (PRECAUTIONS AND GENERAL INFORMATIONS).

CAUTION

Do not repair faulty fuses. Never use fuses different from the recommended ones. The use of unsuitable fuses may cause damages to the electric system or, in case of short circuit, even a fire.

NOTE If a fuse blows frequently, there probably is a short circuit or an overload in the electric system.

If an electric component does not work or works irregularly, or if the vehicle fails to start, it is necessary to check the fuses.

Check first the 15A secondary fuses and then the 30 A primary fuses.

For the check, proceed as follows:

- ◆ Turn the ignition switch to position "OFF", to avoid any accidental short circuit.
- ◆ Loosen the screw (1).
- ◆ Move the safety clip (2).
- ◆ Open the cover of the box (3) containing the secondary fuses.
- ◆ Extract the fuses one by one and check if the filament (4) is broken.
- ◆ Before replacing the fuse, try to find out the cause of the trouble, if possible.
- ◆ Replace the damaged fuse with a new one having the same amperage.

NOTE If you use one of the spare fuses, put a new fuse in the proper seat.

- ◆ Put back the rider saddle, see 7.1.1 (REMOVING THE RIDER SADDLE).
- ◆ Carry out the operations previously described for the secondary fuses also for the main fuses.

NOTE The removal of the 30 A fuses requires the setting to zero of the following functions: digital clock and red line setting. To reset these functions, see 2.3 (MULTI-FUNCTION COMPUTER).

ARRANGEMENT OF THE 15 A SECONDARY FUSES

- A) From voltage regulator to: high beam relay, low beam relay.
- B) From voltage regulator to: coils, engine stop relay, fuel pump.
- C) From ignition switch to: electric fans, clock.
- D) From ignition switch to: parking lights, rear stoplights, horn, dashboard lights, direction indicators.
- E) From ignition switch to: electronic unit, fuel pump relay, engine stop relay.

NOTE Three fuses are spare fuses.

ARRANGEMENT OF THE 30 A MAIN FUSES

- F) From battery to: ignition.
- G) From battery to: ignition.

NOTE One fuse is a spare fuse.

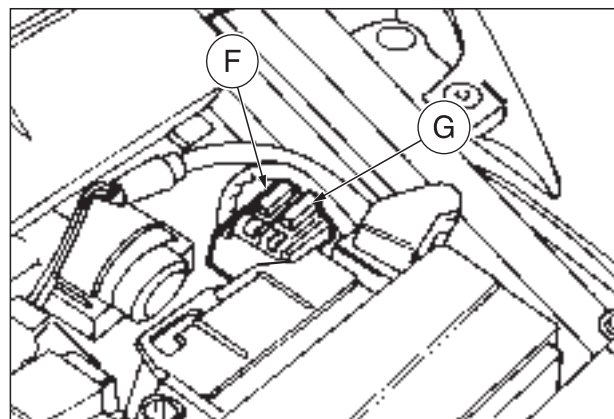
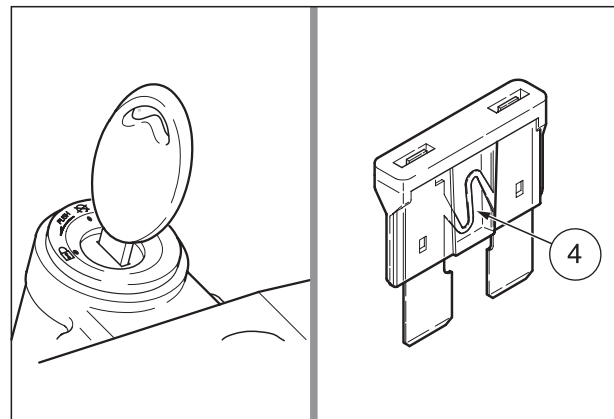
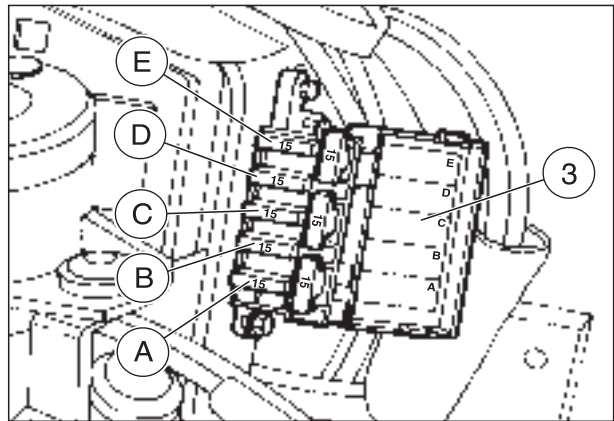
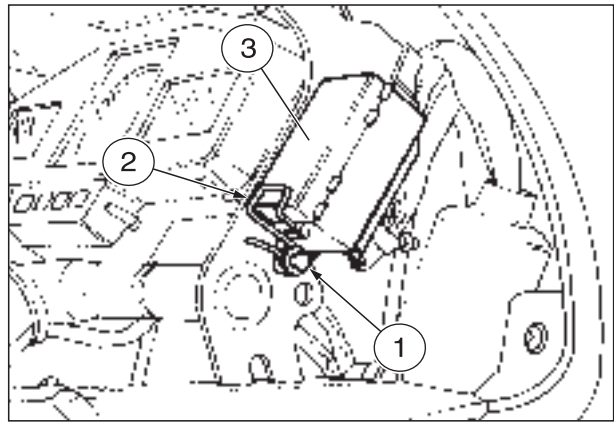

6.16 CHECKING THE SWITCHES

Carefully read 0.5.1 (PRECAUTIONS AND GENERAL INFORMATIONS).

The vehicle is provided with four switches:

- Stoplight switch on the rear brake control lever (1).
 - Stoplight switch on the front brake control lever (2).
 - Safety switch on the side stand (3).
 - Switch on the clutch control lever (4).
- ◆ Make sure that there are no dirt or mud deposits on the switch; the pin must be able to move without interferences, returning automatically to its initial position.
 - ◆ Make sure that the cables are connected correctly.
 - ◆ Check the spring (5): it must not be damaged, worn or weakened.

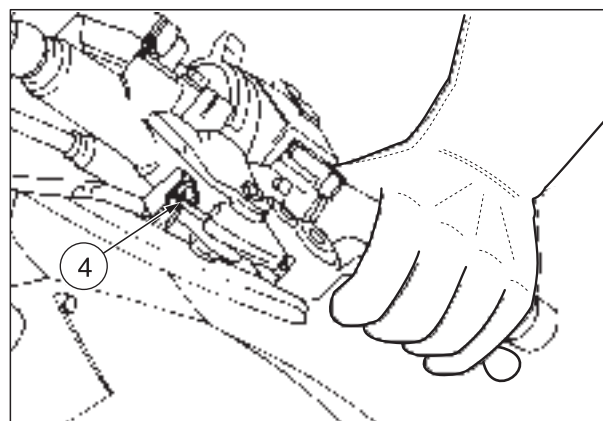
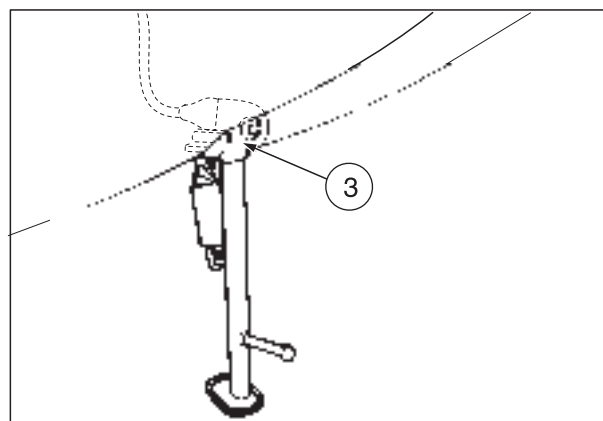
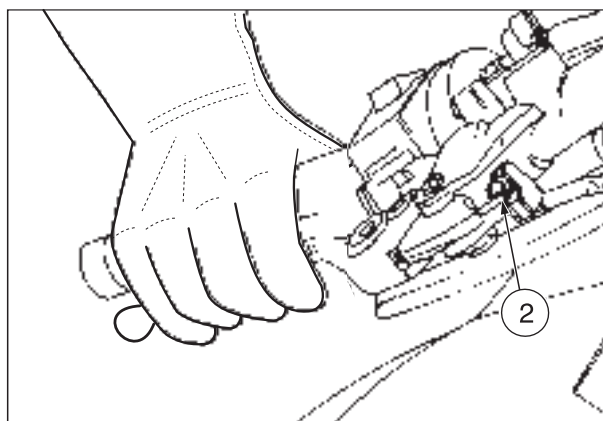
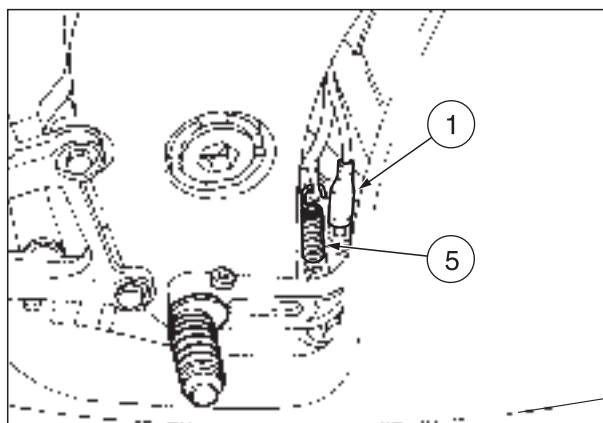

6.17 CONNECTIONS TO THE ENGINE CONTROL UNIT

NOTE See 6.2 (ELECTRIC COMPONENTS LAYOUT) for the positioning of the components.

For further information, see 4.7.4 (ENGINE CONTROL UNIT CONNECTORS).

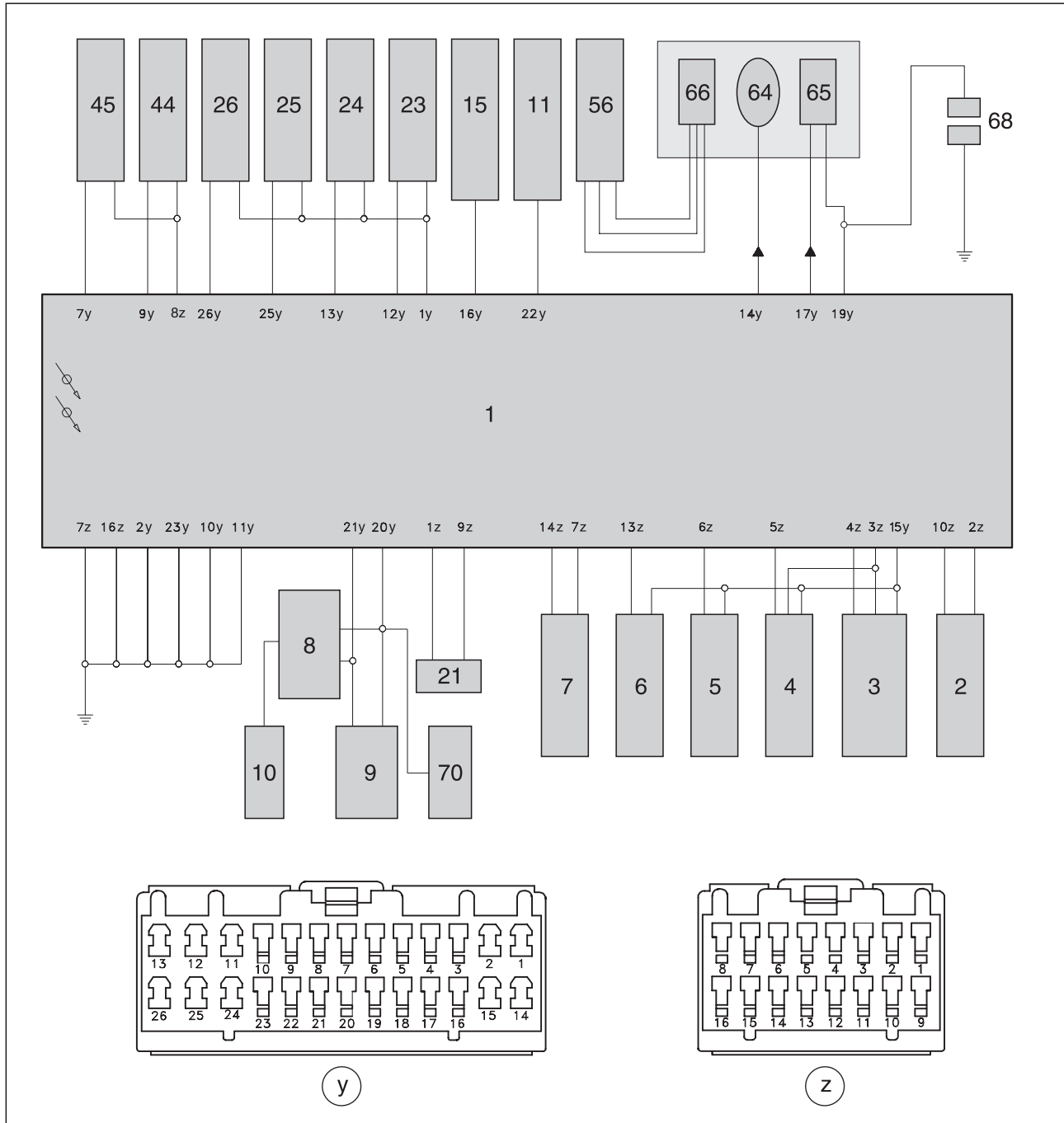

NOTE The initials (y) and (z) appearing in the diagram, next to the relevant numbers, mark the respective terminals on both connectors.

- y) Electronic unit connector (26-way).
- z) Electronic unit connector (16-way)

Follow ►

Follow ►

Position	Component	Connector	Terminal #	Nominal value	Cable colours
1	Electronic unit	–	–	–	–
2	Camshaft position sensor	z	2	150 – 300 Ω	Vi /N
		z	10		Gr/N
3	Throttle valve potentiometer	y	15	2.8 – 3.4 kΩ (angle variable)	B/R
		z	3		M/Bi
		z	4		M/G
4	Intake pressure sensor	y	15	10 – 15 kΩ	B/R
		z	3		M/Bi
		z	5		Ro
5	Coolant thermistor	y	15	1.9 – 2.9 kΩ	B/R
		z	6		Ro/N
6	Air thermistor	y	15	–	B/R
		z	13		Ro/V
7	Fall sensor	z	7	> 10 kΩ	Earth
		z	14		Ro/Bi
8	Diode module	y	20	–	M/V
		y	21		M/Vi
9	Clutch control lever switch	y	20	–	M/V
		y	21		M/Vi
10	Neutral gear switch	–	–	–	M
11	Start relay	y	22	–	G/R
15	Fuel pump relay	y	16	–	Ar/G
21	Driving shaft position sensor	z	9	150 – 300 Ω	Bi/G
		z	1		B/G
–	Earth	y	2–10–11–23	–	B/V
		z	7 – 16		
23	Rear cylinder coil	y	1	4 – 5 Ω	V/Gr
		y	12		Az/G
24	Rear cylinder coil	y	1	4 – 5 Ω	V/Gr
		y	13		Ro/G
25	Front cylinder coil	y	1	4 – 5 Ω	V/Gr
		y	25		Ro/G
26	Front cylinder coil	y	1	4 – 5 Ω	V/Gr
		y	26		Ar/Bi
44	Front cylinder injector	z	8	11 – 17 Ω	V/N
		y	9		Gr/R
45	Rear cylinder injector	z	8	11 – 17 Ω	V/N
		y	7		M/R
56	Speed sensor	–	–	–	B/Ar Gr/Bi V/Vi
64	Revolution counter	y	14	–	Gr/Vi
65	Multifunction display (right side) - Diagnostics	y	17	–	B/Vi
66	Multifunction display (left side)	–	–	–	B/Ar Gr/Bi V/Vi
68	TEST connectors	y	19	–	V/Bi

6.18 WIRING DIAGRAM - RSV mille

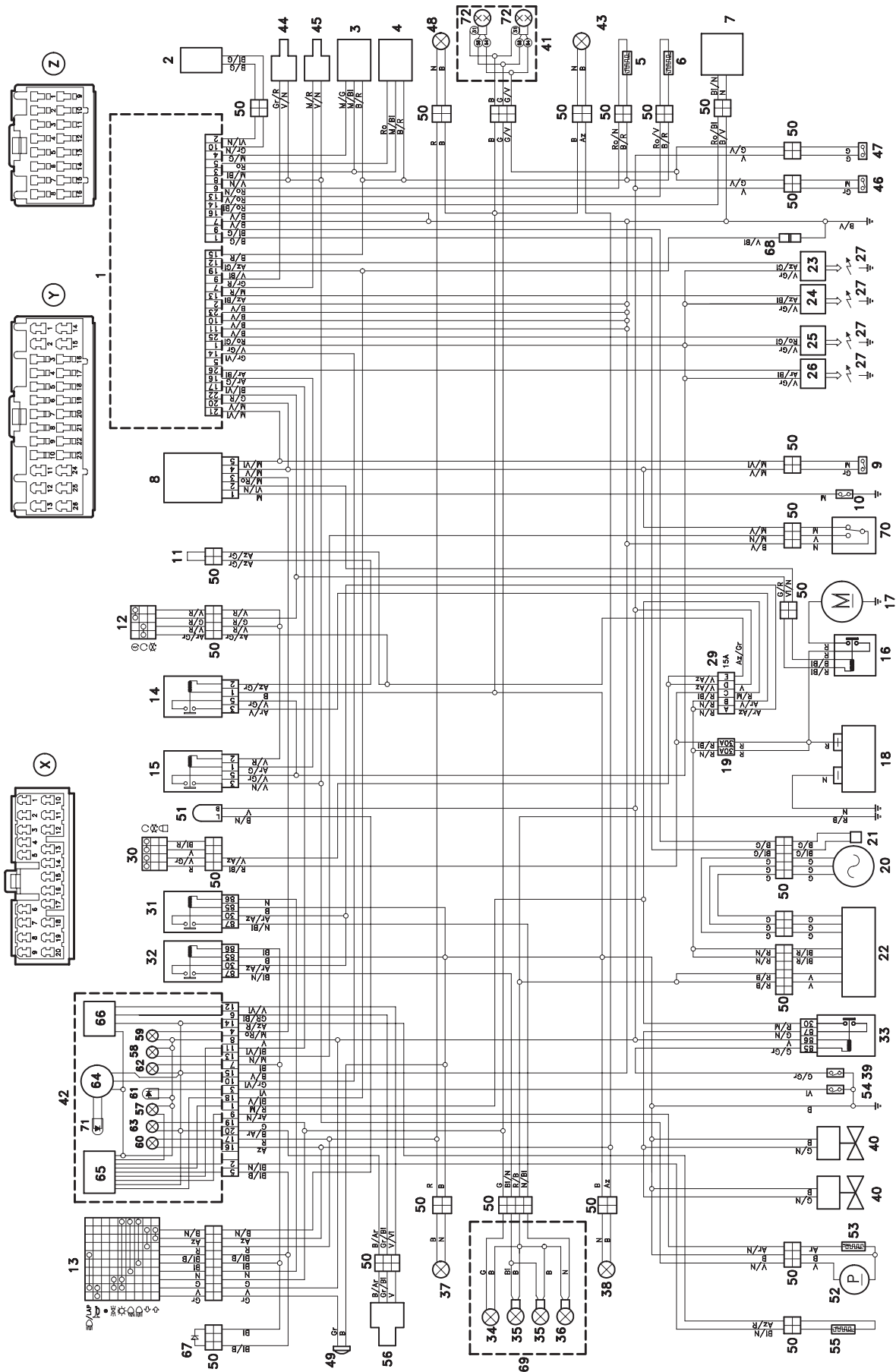

WIRING DIAGRAM KEY - RSV mille

- | | |
|---|---|
| 1) Electronic unit | 35) High beam bulbs |
| 2) Cam position sensor | 36) Low beam bulb |
| 3) Throttle valve position sensor | 37) Front right direction indicator |
| 4) Intake pressure sensor | 38) Front left direction indicator |
| 5) Coolant thermistor | 39) Thermal switch |
| 6) Air thermistor | 40) Cooling fans |
| 7) Fall sensor | 41) Rear light |
| 8) Diode module | 42) Dashboard |
| 9) Clutch control lever switch | 43) Rear left direction indicator |
| 10) Neutral gear switch | 44) Front cylinder injector |
| 11) Arrangement for the installation of the anti-theft device | 45) Rear cylinder injector |
| 12) Right dimmer switch | 46) Front stoplight switch |
| 13) Left dimmer switch | 47) Rear stoplight switch |
| 14) Engine stop relay | 48) Rear right direction indicator |
| 15) Fuel pump relay | 49) Horn |
| 16) Start relay | 50) Multiple connectors |
| 17) Starter | 51) Blinking |
| 18) Battery | 52) Fuel pump |
| 19) Main fuses (30A) (ignition) | 53) Low fuel sensor |
| 20) Generator | 54) Engine oil pressure switch |
| 21) Pick up | 55) Coolant temperature thermistor |
| 22) Voltage regulator | 56) Speed sensor |
| 23) Rear cylinder coil | 57) Low fuel warning light |
| 24) Rear cylinder coil | 58) Side stand down warning light |
| 25) Front cylinder coil | 59) Neutral warning light |
| 26) Front cylinder coil | 60) Direction indicator warning light |
| 27) Spark plugs | 61) Engine oil pressure warning light LED |
| 28) – | 62) High beam warning light |
| 29) Secondary fuses (15A) | 63) Dashboard bulbs |
| A - High beam, low beam | 64) Revolution counter |
| B - ISC, coils, fuel pump | 65) Multifunction display (right side) |
| C - Electric fans, clock | 66) Multifunction display (left side) |
| D - Parking lights, stoplights, horn, dashboard lights, direction indicators. | 67) Lights diode/LAP |
| E - Electronic unit, fuel pump relay, engine stop relay. | 68) TEST connectors |
| 30) Ignition switch | 69) Headlight |
| 31) Low beam relay | 70) Side stand switch |
| 32) High beam relay | 71) Red line warning light LED |
| 33) Cooling fan relay | 72) Rear parking light/stoplight bulbs |
| 34) Front parking light bulb | |
| | X) Dashboard connector (20-way) |
| | Y) Electronic unit connector (26-way) |
| | Z) Electronic unit connector (16-way) |

CABLE COLOURS

- | | |
|-----------|------------|
| Ar | orange |
| Az | light blue |
| B | blue |
| Bi | white |
| G | yellow |
| Gr | grey |
| M | brown |
| N | black |
| R | red |
| V | green |
| Vi | violet |
| Ro | pink |

6.19 WIRING DIAGRAM - RSV mille ASD

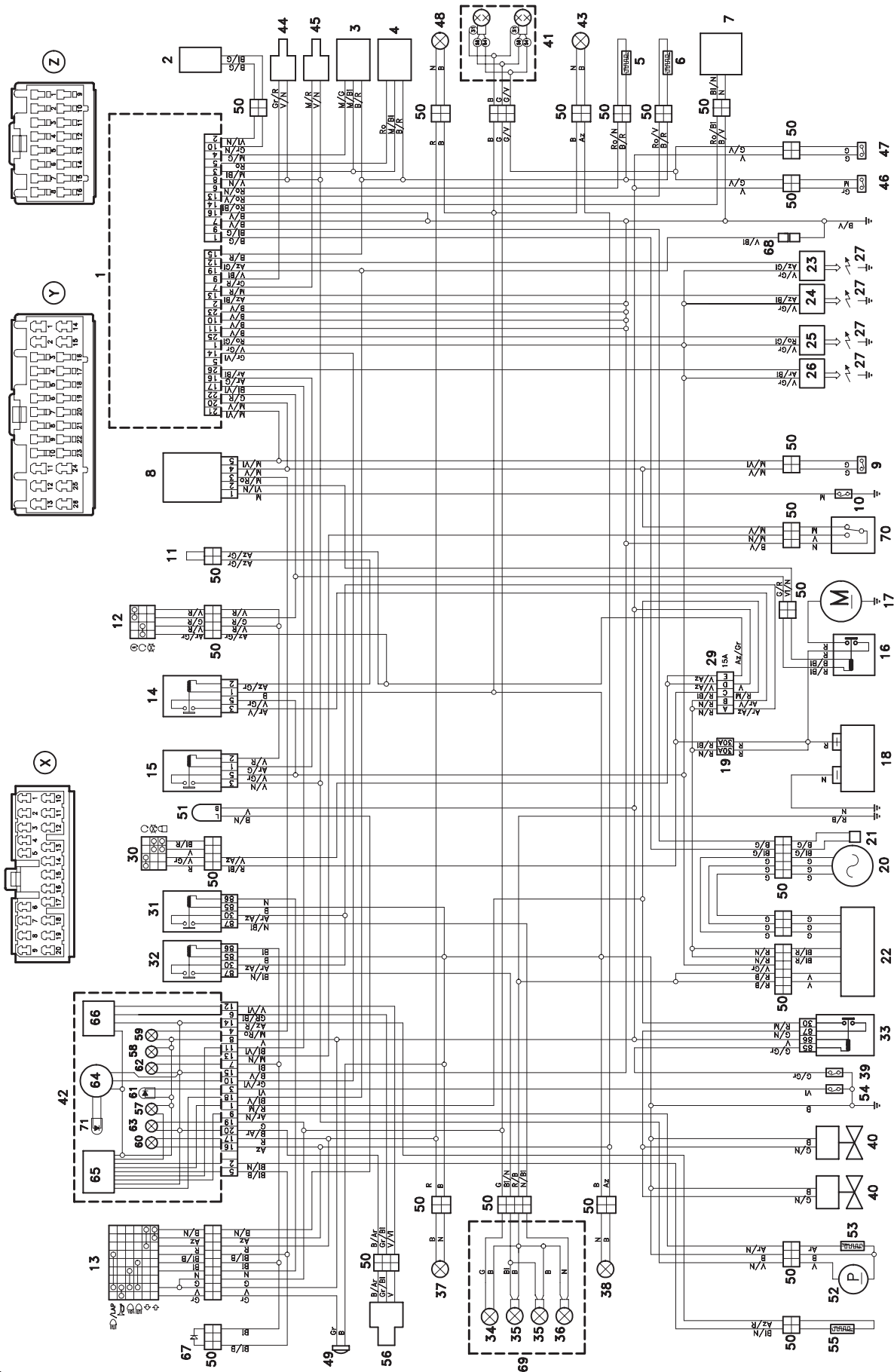

WIRING DIAGRAM KEY - RSV mille ASD

- | | |
|---|---|
| 1) Electronic unit | 35) High beam bulbs |
| 2) Cam position sensor | 36) Low beam bulb |
| 3) Throttle valve position sensor | 37) Front right direction indicator |
| 4) Intake pressure sensor | 38) Front left direction indicator |
| 5) Coolant thermistor | 39) Thermal switch |
| 6) Air thermistor | 40) Cooling fans |
| 7) Fall sensor | 41) Rear light |
| 8) Diode module | 42) Dashboard |
| 9) Clutch control lever switch | 43) Rear left direction indicator |
| 10) Neutral gear switch | 44) Front cylinder injector |
| 11) Arrangement for the installation of the anti-theft device | 45) Rear cylinder injector |
| 12) Right dimmer switch | 46) Front stoplight switch |
| 13) Left dimmer switch | 47) Rear stoplight switch |
| 14) Engine stop relay | 48) Rear right direction indicator |
| 15) Fuel pump relay | 49) Horn |
| 16) Start relay | 50) Multiple connectors |
| 17) Starter | 51) Blinking |
| 18) Battery | 52) Fuel pump |
| 19) Main fuses (30A) (ignition) | 53) Low fuel sensor |
| 20) Generator | 54) Engine oil pressure switch |
| 21) Pick up | 55) Coolant temperature thermistor |
| 22) Voltage regulator | 56) Speed sensor |
| 23) Rear cylinder coil | 57) Low fuel warning light |
| 24) Rear cylinder coil | 58) Side stand down warning light |
| 25) Front cylinder coil | 59) Neutral warning light |
| 26) Front cylinder coil | 60) Direction indicator warning light |
| 27) Spark plugs | 61) Engine oil pressure warning light LED |
| 28) – | 62) High beam warning light |
| 29) Secondary fuses (15A) | 63) Dashboard bulbs |
| A - High beam, low beam | 64) Revolution counter |
| B - ISC, coils, fuel pump | 65) Multifunction display (right side) |
| C - Electric fans, clock | 66) Multifunction display (left side) |
| D - Parking lights, stoplights, horn, dashboard lights, direction indicators. | 67) Lights diode/LAP |
| E - Electronic unit, fuel pump relay, engine stop relay. | 68) TEST connectors |
| 30) Ignition switch | 69) Headlight |
| 31) Low beam relay | 70) Side stand switch |
| 32) High beam relay | 71) Red line warning light LED |
| 33) Cooling fan relay | 72) Rear parking light/stoplight bulbs |
| 34) Front parking light bulb | X) Dashboard connector (20-way) |
| | Y) Electronic unit connector (26-way) |
| | Z) Electronic unit connector (16-way) |

CABLE COLOURS

- | | |
|-----------|------------|
| Ar | orange |
| Az | light blue |
| B | blue |
| Bi | white |
| G | yellow |
| Gr | grey |
| M | brown |
| N | black |
| R | red |
| V | green |
| Vi | violet |
| Ro | pink |

CHASSIS

7

CHASSIS

TABLE OF CONTENTS

7.1 BODY 7-3-00

7.1.1 REMOVING THE RIDER SADDLE 7-5-00

7.1.2 UNLOCKING/LOCKING THE PASSENGER SEAT 7-5-00

7.1.3 REMOVING THE SIDE COVERS 7-6-00

7.1.4 REMOVING THE FUEL TANK FILLER CAP 7-6-00

7.1.5 PARTIAL REMOVAL OF THE FUEL TANK 7-7-00

7.1.6 COMPLETE REMOVAL OF THE FUEL TANK 7-8-00

7.1.7 REMOVING THE AIR CLEANER CASE 7-9-00

7.1.8 REMOVING THE BATTERY 7-10-00

7.1.9 REMOVING THE ELECTRONIC UNIT 7-10-00

7.1.10 REMOVING THE ANTIVIBRATION WEIGHT 7-11-00

7.1.11 REMOVING THE COLD-START CONTROL 7-11-00

7.1.12 REMOVING THE GRIPS 7-12-00

7.1.13 REMOVING THE CLUTCH LEVER 7-13-00

7.1.14 REMOVING THE ELECTRIC CONTROLS ON THE LEFT HANDLEBAR 7-14-00

7.1.15 REMOVING THE THROTTLE GRIP 7-15-00

7.1.16 REMOVING THE FRONT BRAKE LEVER 7-15-00

7.1.17 REMOVING THE ELECTRIC CONTROLS ON THE RIGHT HANDLEBAR 7-17-00

7.1.18 REMOVING THE IGNITION SWITCH/STEERING LOCK 7-18-00

7.1.19 REMOVING THE FORK UPPER PLATE 7-19-00

7.1.20 REMOVING THE RIGHT AND LEFT HANDLEBARS 7-20-00

7.1.21 REMOVING THE REAR-VIEW MIRRORS 7-21-00

7.1.22 REMOVING THE FRONT PART OF THE FAIRING 7-21-00

7.1.23 REMOVING THE HEADLIGHT 7-22-00

7.1.24 REMOVING THE DASHBOARD'S UPPER PROTECTION MOULDING 7-22-00

7.1.25 REMOVING THE DASHBOARD 7-22-00

7.1.26 REMOVING THE DASHBOARD/FRONT FAIRING MOUNT 7-23-00

7.1.27 REMOVING THE FRONT MUDGUARD 7-23-00

7.1.28 REMOVING THE SIDE FAIRINGS 7-24-00

7.1.29 REMOVING THE SIDE FAIRING UPPER PANELS 7-24-00

7.1.30 REMOVING THE FRONT DIRECTION INDICATORS 7-24-00

7.1.31 REMOVING THE AIR CONVEYOR COVERS 7-25-00

7.1.32 REMOVING THE FRONT FAIRING LOWER LOCKUP 7-25-00

7.1.33 REMOVING THE AIR CONVEYOR 7-26-00

7.1.34 REMOVING THE LOWER FAIRING 7-27-00

7.1.35 REMOVING THE RADIATOR SPOILER 7-28-00

7.1.36 REMOVING THE REAR FAIRING REAR END 7-29-00

7.1.37 REMOVING THE REAR LIGHT 7-29-00

7.1.38 REMOVING THE REAR FAIRING 7-30-00

7.1.39 REMOVING THE PASSENGER SEAT LOCK 7-31-00

7.1.40 REMOVING THE REAR DIRECTION INDICATORS 7-31-00

7.1.41 REMOVING THE SADDLE SUPPORT LOWER MOULDED COVER 7-32-00

7.1.42 REMOVING THE NUMBER PLATE HOLDER 7-34-00

7.1.43 REMOVING THE REAR MUDGUARD 7-34-00

7.1.44 REMOVING THE PASSENGER FOOTREST SUPPORTS 7-34-00

7.1.45 REMOVING THE PASSENGER FOOTREST 7-35-00

7.1.46 REMOVING THE RIDER'S FOOTREST SUPPORTS 7-35-00

7.1.47 REMOVING THE RIDER'S FOOTREST 7-36-00

7.1.48 REMOVING THE REAR BRAKE LEVER 7-36-00

7.1.49 REMOVING THE EXHAUST SILENCER 7-37-00

7.1.50 REMOVING THE SIDE STAND 7-38-00

7.1.51 REMOVING THE ENGINE OIL TANK 7-39-00

7.1.52 REMOVING THE ENGINE OIL RADIATOR 7-40-00

7.1.53 REMOVING THE DRIVE PINION 7-40-00

7.1.54 REMOVING THE DRIVING CHAIN SHOE 7-41-00

7.1.55 DRAINING THE CLUTCH CONTROL SYSTEM 7-41-00

7.1.56 REMOVING THE SADDLE SUPPORT 7-42-00

7.1.57 REMOVING THE FRAME 7-43-00

7.2 FRONT WHEEL 7-45-00

7.2.1 REMOVING THE FRONT WHEEL 7-46-00

7.2.2 CHECKING THE FRONT WHEEL COMPONENTS 7-47-00

7.2.3 FRONT WHEEL BEARINGS 7-47-00

7.2.4 FRONT WHEEL GASKETS 7-48-00

7.2.5 FRONT WHEEL PIN 7-48-00

7.2.6 FRONT WHEEL RIM 7-48-00

7.2.7 FRONT TYRE 7-48-00

7.2.8 FRONT BRAKE DISCS 7-48-00

7.2.9 DISASSEMBLING THE FRONT WHEEL BEARINGS 7-49-00

7.2.10 ASSEMBLING THE FRONT WHEEL BEARINGS 7-50-00

7.2.11 INSTALLING THE FRONT WHEEL 7-51-00

7.3 REAR WHEEL 7-52-00

7.3.1 REMOVING THE REAR WHEEL 7-53-00

7.3.2 REMOVING THE FINAL DRIVE UNIT 7-54-00

7.3.3 CHECKING THE REAR WHEEL COMPONENTS 7-55-00

7.3.4 REAR WHEEL BEARINGS 7-55-00

7.3.5 REAR WHEEL GASKETS 7-56-00

7.3.6 REAR WHEEL PIN 7-56-00

7.3.7 REAR WHEEL RIM 7-56-00

7.3.8 REAR TYRE 7-56-00

7.3.9 REAR BRAKE DISCS 7-56-00

7.3.10 FINAL DRIVE UNIT BEARINGS 7-57-00

7.3.11 FLEXIBLE COUPLINGS 7-58-00

7.3.12 SPROCKET 7-58-00

7.3.13 DISASSEMBLING THE REAR WHEEL BEARINGS 7-59-00

7.3.14 ASSEMBLING THE REAR WHEEL BEARINGS 7-60-00

7.3.15 DISASSEMBLING THE FINAL DRIVE UNIT BEARINGS 7-61-00

7.3.16 ASSEMBLING THE FINAL DRIVE UNIT BEARINGS 7-62-00

7.3.17 REMOVING THE FLEXIBLE COUPLINGS 7-63-00

7.3.18 REMOVING THE CROWN GEAR 7-64-00

7.3.19 REMOVING THE FLEXIBLE COUPLING HOLDER ^{RSV} 7-65-00

7.3.20 CHANGING THE WHEEL RIM 7-65-00

7.3.21 INSTALLING THE REAR WHEEL 7-66-00

7.4 TYRES 7-67-00

7.4.1 TYRE DISASSEMBLY 7-67-00

7.4.2 CHECKING THE COMPONENTS 7-67-00

7.4.3 ASSEMBLING THE TYRE 7-68-00

7.5 FRONT BRAKE 7-69-00

7.5.1 CHANGING THE FRONT BRAKE PADS (models up to 2001) 7-70-00

7.5.2 CHANGING THE FRONT BRAKE PADS ^{RSV01} 7-71-00

7.5.3 CHECKING THE FRONT BRAKE DISCS 7-72-00

7.5.4 REMOVING THE FRONT BRAKE DISCS 7-72-00

7.5.5 REMOVING THE FRONT BRAKE PUMP 7-72-00

7.5.6 REMOVING THE FRONT BRAKE CALIPERS 7-73-00

7.5.7 DRAINING THE BRAKING SYSTEMS 7-75-00

7.6 REAR BRAKE 7-76-00

7.6.1 CHANGING THE REAR BRAKE PADS 7-77-00

7.6.2 CHECKING THE REAR BRAKE DISC 7-77-00

7.6.3 REMOVING THE REAR BRAKE DISC 7-78-00

7.6.4 REMOVING THE REAR BRAKE PUMP 7-79-00

7.6.5 REMOVING THE REAR BRAKE CALIPER 7-80-00

7.6.6 DRAINING THE REAR BRAKING SYSTEM 7-81-00

7.7 STEERING 7-82-00

7.7.1 REMOVING THE FORK TOGETHER WITH THE FRONT WHEEL 7-83-00

7.7.2 CHECKING THE COMPONENTS 7-85-00

7.7.3 STEERING BEARINGS 7-85-00

7.7.4 STEERING GASKETS 7-85-00

7.7.5 REMOVING THE STEERING BEARINGS 7-86-00

7.7.6 REMOVING THE STEERING SHOCK ABSORBER 7-86-00

7.8 FRONT FORK 7-87-00

7.8.1 CHANGING THE FORK OIL 7-88-00

7.8.2 REMOVING THE WHEEL-HOLDER TUBE - SLIDER UNITS 7-88-00

7.8.3 DISASSEMBLING THE WHEEL-HOLDER TUBE - SLIDER UNIT 7-89-00

7.8.4 CHECKING THE COMPONENTS 7-94-00

7.8.5 REASSEMBLING THE WHEEL-HOLDER TUBE - SLIDER UNIT 7-95-00

7.8.6 INSTALLING THE WHEEL-HOLDER TUBE - SLIDER UNITS 7-100-00

7.9 REAR FORK 7-101-00

7.9.1 REMOVING THE REAR FORK 7-101-00

7.9.2 CHECKING THE COMPONENTS 7-103-00

7.9.3 REAR FORK BEARINGS 7-103-00

7.9.4 REAR FORK GASKETS 7-103-00

7.9.5 REAR FORK PIN 7-103-00

7.9.6 DISASSEMBLING THE REAR FORK GASKETS 7-104-00

7.9.7 REASSEMBLING THE REAR FORK 7-105-00

7.10 REAR SUSPENSION 7-107-00

7.10.1 REMOVING THE SHOCK ABSORBER (models up to 2001) 7-107-00

7.10.2 REMOVING THE SHOCK ABSORBER ^{RSV01} 7-108-00

7.10.3 CHECKING THE COMPONENTS 7-109-00

7.10.4 DISASSEMBLING THE REAR SUSPENSION LINKAGE 7-110-00

7.10.5 DISASSEMBLING THE SUSPENSION LINKAGE 7-110-00

7.11 DISASSEMBLING THE DRIVING CHAIN 7-111-00

7.11.1 CHAIN BREAKER/RIVET TOOL ^{OPT} 7-111-00

7.11.2 BREAKING THE CHAIN 7-112-00

7.11.3 POSITIONING THE JOINING LINK 7-113-00

7.11.4 RIVETTING THE PINS 7-113-00

7.1 BODY

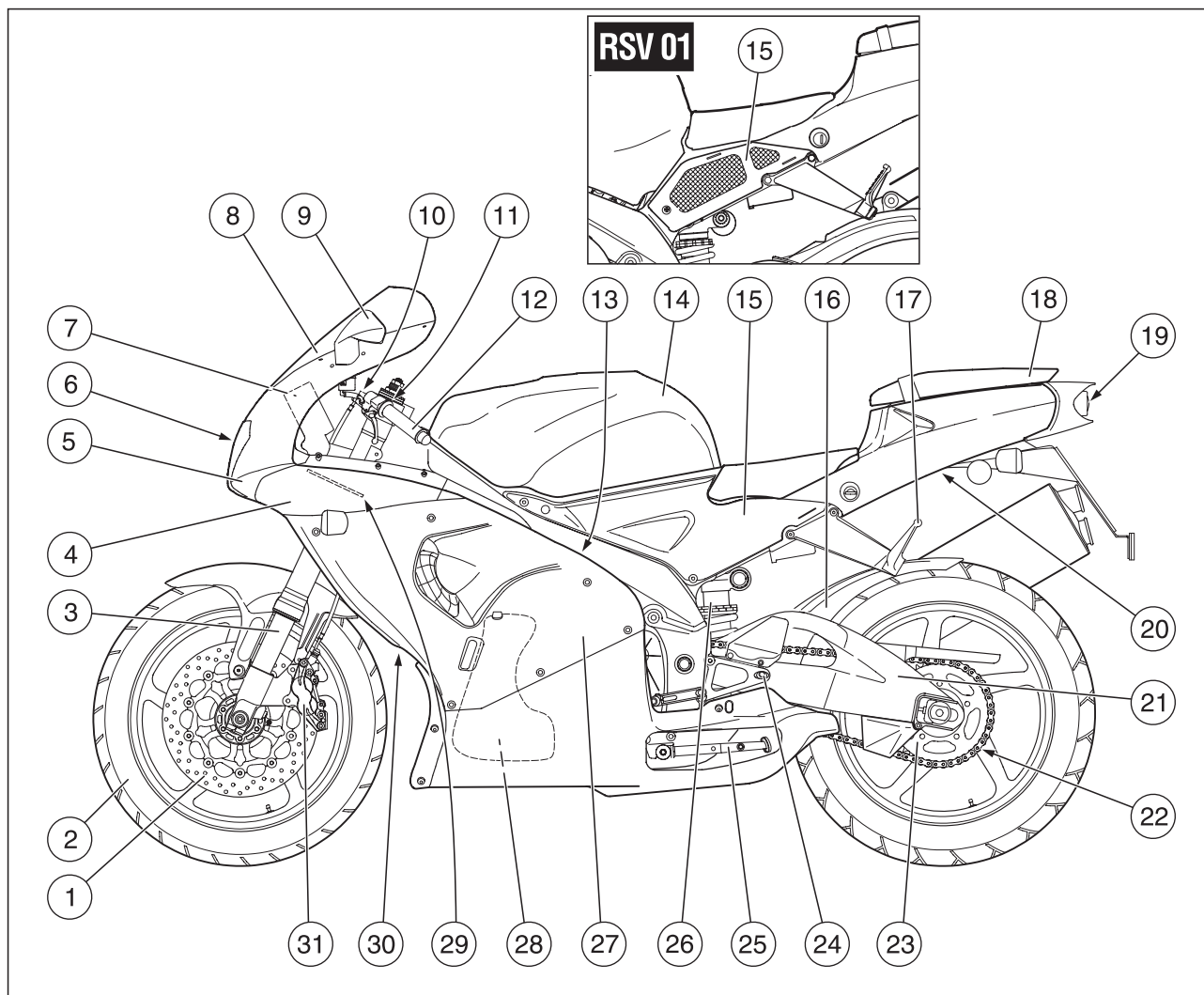

Key

- | | |
|-------------------------------------|--|
| 1) Left front brake disc | 17) Passenger left footrest |
| 2) Front wheel | 18) Passenger seat |
| 3) Front fork | 19) Rear light |
| 4) Left air conveyor cover | 20) Saddle support lower moulded cover |
| 5) Left air conveyor | 21) Rear fork |
| 6) Headlight | 22) Drive chain |
| 7) Dashboard | 23) Sprocket |
| 8) Front fairing | 24) Rider left footrest |
| 9) Left rear-view mirror | 25) Side stand |
| 10) Ignition switch / steering lock | 26) Shock absorber |
| 11) Controls on left handlebar | 27) Left fairing |
| 12) Left handgrip | 28) Engine oil tank |
| 13) Left fairing upper panel | 29) Front fairing lower lockup |
| 14) Fuel tank | 30) Radiator spoiler |
| 15) Left side cover | 31) Front brake left caliper |
| 16) Rear mudguard | |

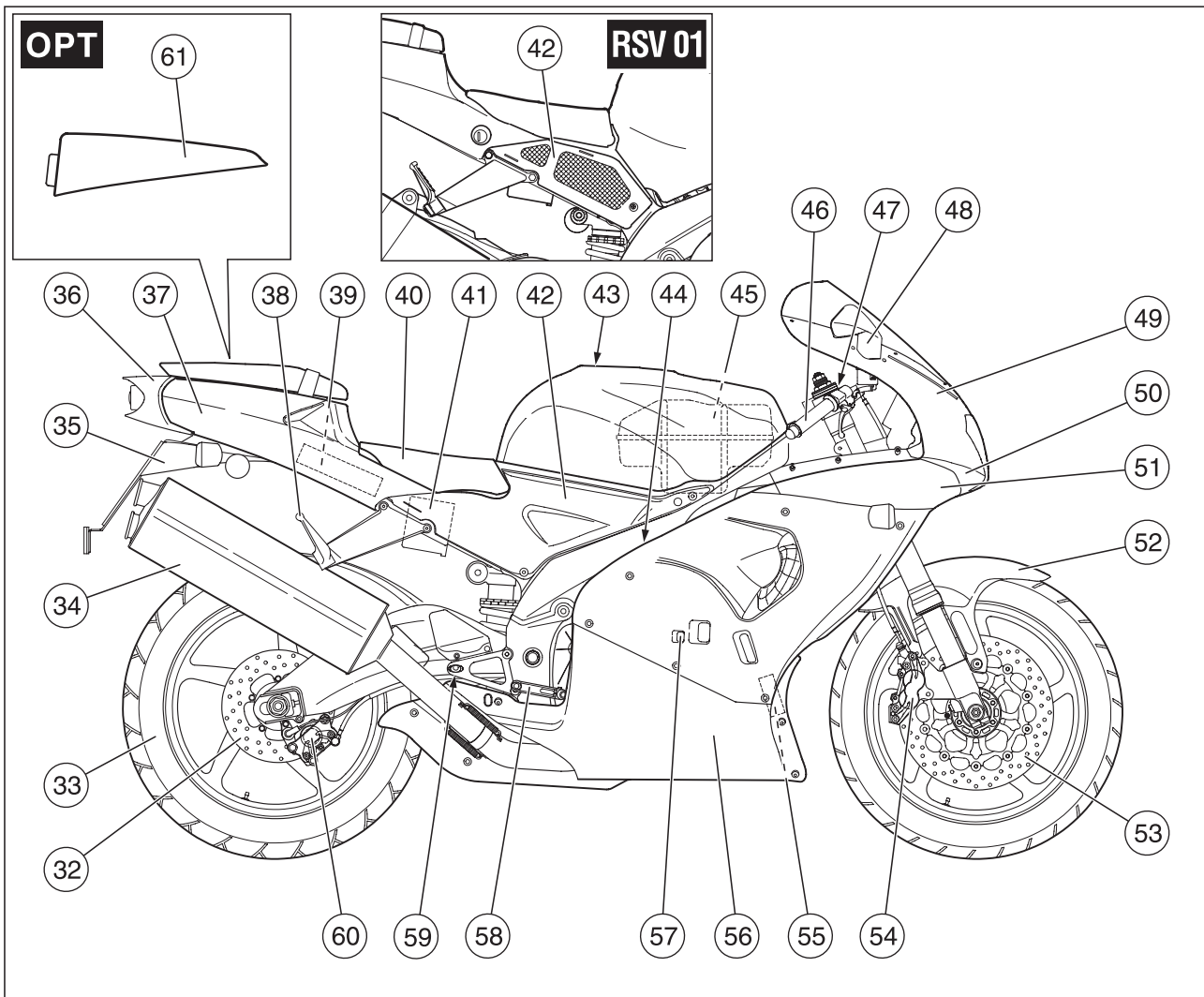

Key

- 32) Rear brake disc
- 33) Rear wheel
- 34) Exhaust silencer
- 35) Number plate holder
- 36) Rear fairing rear end
- 37) Rear fairing
- 38) Passenger right footrest
- 39) Electronic unit
- 40) Rider saddle
- 41) Battery
- 42) Right side cover
- 43) Fuel tank filler cap
- 44) Right fairing upper panel
- 45) Air filter casing
- 46) Right handgrip (throttle grip)
- 47) Controls on the right part of the handlebar
- 48) Right rear-view mirror
- 49) Dashboard's upper protection moulding
- 50) Right air conveyor
- 51) Right air conveyor cover
- 52) Front mudguard
- 53) Right front brake disc
- 54) Right front brake caliper
- 55) Engine oil radiator
- 56) Lower fairing
- 57) Right fairing
- 58) Rear brake control lever
- 59) Rider right footrest
- 60) Rear brake caliper
- 61) Glove compartment/tool kit cover **OPT**

7.1.1 REMOVING THE RIDER SADDLE

- ◆ Position the vehicle on the stand.
- ◆ ★ Partially raise the rear side edge of the saddle.
- ◆ ★ Unscrew and remove the screw (1) and take the bushing (2).

Screw (1) driving torque: 12 Nm (1.2 kgm).

- ◆ Raise and remove the saddle (3).

NOTE Upon reassembly, insert the front tang of the saddle in the appropriate seat.

⚠ CAUTION

Before leaving, make sure that the saddle (3) is properly positioned and locked.

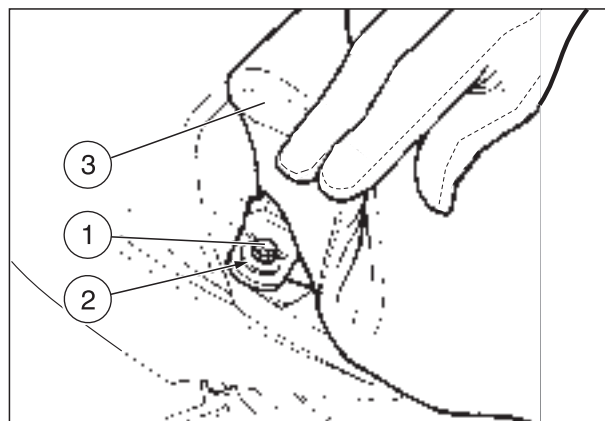

7.1.2 UNLOCKING/LOCKING THE PASSENGER SEAT

- ◆ Position the vehicle on the stand.
- ◆ Introduce the key (4) in the seat lock (5).
- ◆ Rotate the key (4) anticlockwise, lift and withdraw the seat (6) from behind.

NOTE Before lowering and locking the seat (6), make sure that you have not left the key in the glove/tool kit compartment.

To lock the seat (6), proceed as follows:

- ◆ Introduce its front part under the passenger grab strap (7).
- ◆ Position the seat and press it, making the lock snap.

NOTE Upon request it is possible to supply the glove / tool kit compartment cover **OPT** to be used instead of the passenger seat.

If the glove/tool kit compartment cover is used, the passenger grab strap must be folded and put inside the glove / tool kit compartment: for the installation and removal, see above.

A useful compartment is available under the glove/tool kit compartment cover; to reach it, it is sufficient to release and remove the flap.

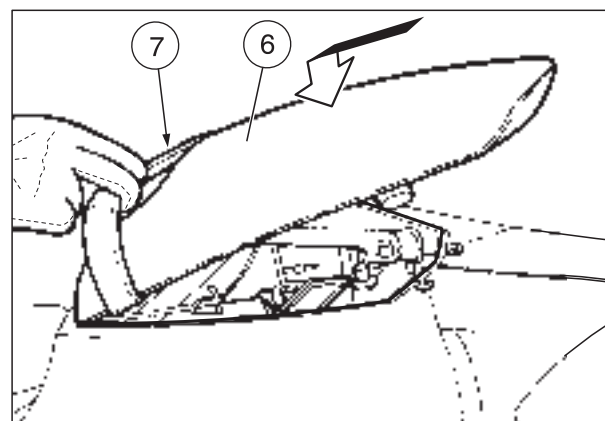
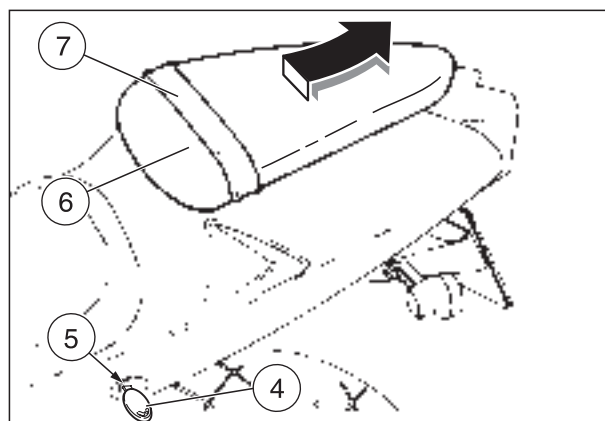

7.1.3 REMOVING THE SIDE COVERS

- ◆ Put back the rider saddle, see 7.1.1 (REMOVING THE RIDER SADDLE).
- ◆ Unscrew and remove the two screws (1).

CAUTION

Handle the plastic and painted components with care to avoid scraping or damaging them.

- ◆ Remove the side cover (2).

NOTE Upon reassembly, make sure that the rear coupling is positioned correctly.

Repeat these operations to remove the other side cover.

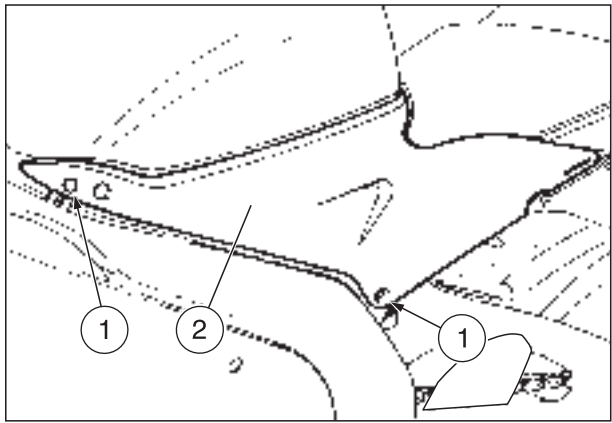

7.1.4 REMOVING THE FUEL TANK FILLER CAP

Carefully read 1.2.1 (FUEL) and 4.1 (FUEL TANK).

WARNING

Fuel vapours are noxious for your health. Before proceeding, make sure that the room in which you are working is properly ventilated. Do not inhale fuel vapours. Do not smoke and do not use naked flames. Do not dispose of fuel in the environment.

FIRE AND/OR EXPLOSION HAZARD.

- ◆ Position the vehicle on the stand.
- ◆ Unscrew and remove the three screws (3).

Screws (3) driving torque: 5 Nm (0.5 kgm).

NOTE The other three screws can be left on the vehicle as they are just for show.

- ◆ Open the cap (4).

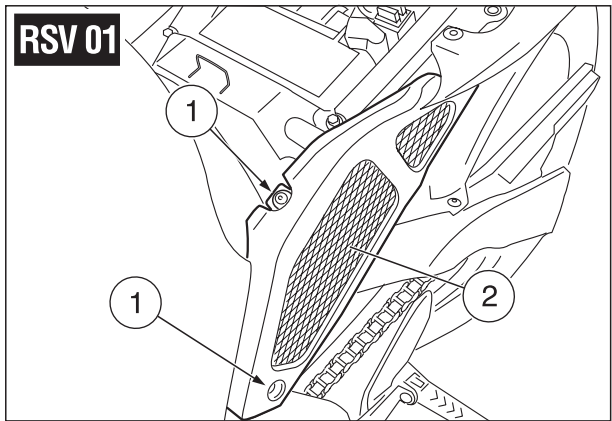

CAUTION

When removing the screw (5), take care not to allow it to fall inside the tank.

- ◆ Unscrew and remove the screw (5).
- ◆ Remove the cap (4) together with the metal ring (6).

CAUTION

Plug the tank opening so as to prevent any foreign bodies falling in.

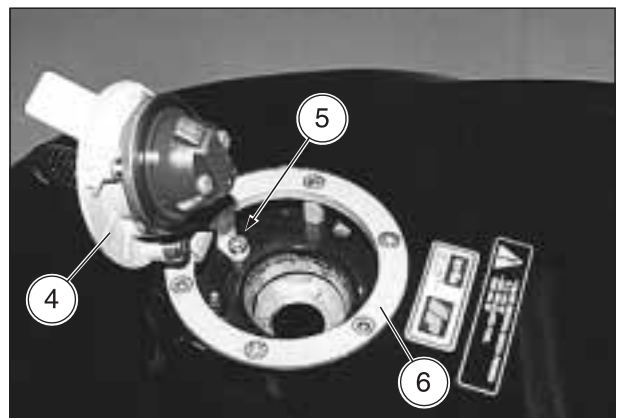
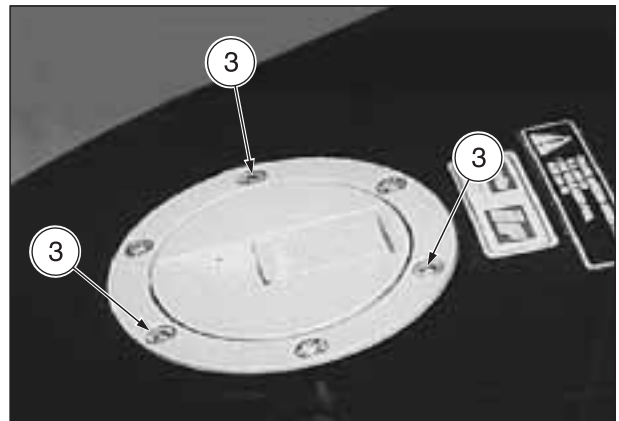

7.1.5 PARTIAL REMOVAL OF THE FUEL TANK

Carefully read 0.5.1 (PRECAUTIONS AND GENERAL INFORMATIONS), 1.2.1 (FUEL) and 4.1 (FUEL TANK).

⚠ WARNING

Fuel vapours are noxious for your health. Before proceeding, make sure that the room in which you are working is properly ventilated. Do not inhale fuel vapours.

Do not smoke and do not use naked flames. Do not dispose of fuel in the environment.

FIRE AND/OR EXPLOSION HAZARD.

Let the engine cool down until it reaches room temperature.

NOTE It is possible to remove the tank from the vehicle when it is full of petrol.

- ◆ Turn the ignition switch to position "⊗".
- ◆ Put back the rider saddle, see 7.1.1 (REMOVING THE RIDER SADDLE).
- ◆ Remove the two side panels, see 7.1.3 (REMOVING THE SIDE COVERS).
- ◆ Disconnect the electric connector (1) from the fuel pump.

⚠ CAUTION

Upon reassembly, make sure that the electric connector (1) is correctly coupled.

- ◆ Slide the overflow tank drain pipe (2) and filler cap water drain pipe (3) off by pulling upwards.
- ◆ Unscrew and remove the two screws (4) front fastening on the tank (5), retrieve the two bushing and should the rubber elements prove damaged, replace them.

Screws (4) driving torque: 12 Nm (1.2 kgm).

⚠ CAUTION

Place a cloth under the male quick-release coupling (6) to catch any fuel spills.

- ◆ Disconnect the male quick-release coupling (6) from the receptacle (7) by pressing the relevant button (8).

⚠ CAUTION

When reassembling, make sure the male quick-release coupling (6) is fitted into the receptacle (7) correctly.

- ◆ Unscrew and remove the four screws (9) fastening the tank rear support plate (10).

Screws (9) driving torque: 12 Nm (1.2 kgm).

- ◆ Set up a work stand approx. 60 cm high next to the vehicle, on its left side, sufficiently wide so that the tank (5) can be set down on it.

⚠ CAUTION

The tank (5) is not completely free, as it is still attached by the fuel delivery pipe which should not be disconnected unless absolutely necessary, see 7.1.6 (COMPLETE REMOVAL OF THE FUEL TANK). Handle the painted components with care and avoid scraping or damaging them.

- ◆ Get a firm hold on the tank (5) at the front and rear, lift it and set it down carefully on the relevant rest without tipping it over.

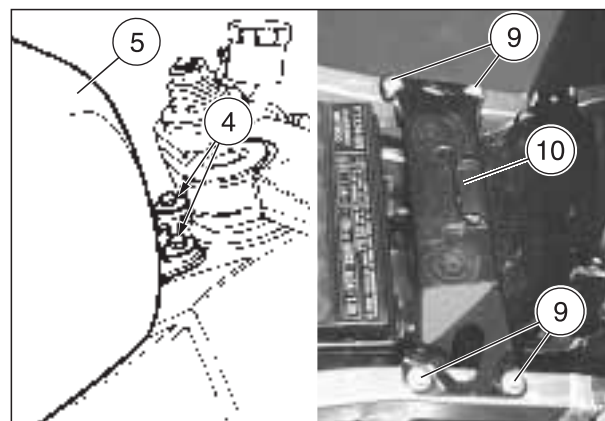
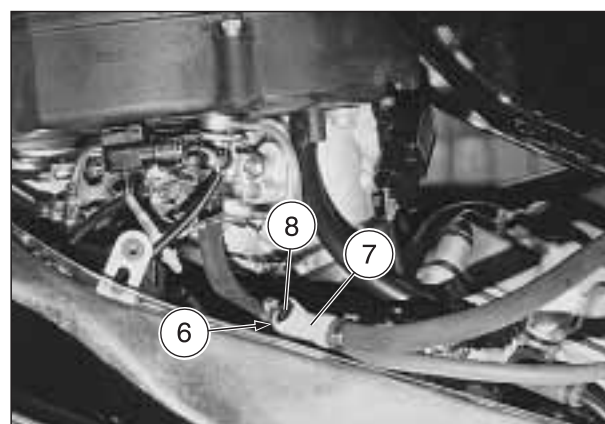
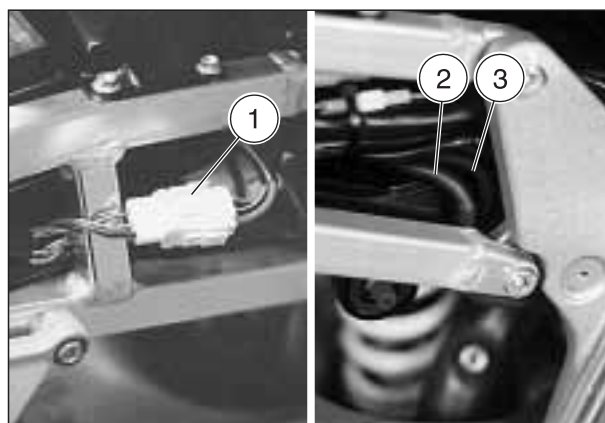

⚠ CAUTION

When reassembling, make sure the tank is positioned correctly (pipes and electric cables must not be twisted and/or squashed).

7.1.6 COMPLETE REMOVAL OF THE FUEL TANK

Carefully read 0.5.1 (PRECAUTIONS AND GENERAL INFORMATIONS), 1.2.1 (FUEL) and 4.1 (FUEL TANK).

⚠ WARNING

Fuel vapours are noxious for your health.
 Before proceeding, make sure that the room in which you are working is properly ventilated.
 Do not inhale fuel vapours.
 Do not smoke and do not use naked flames.
 Do not dispose of fuel in the environment.

FIRE AND/OR EXPLOSION HAZARD.

- ◆ Drain the tank of petrol, see 2.9 (DRAINING THE FUEL TANK).
- ◆ Partially remove the tank, see 7.1.5 (PARTIAL REMOVAL OF THE FUEL TANK).
- ◆ Turn the tank upside down.

⚠ CAUTION

Place a cloth under the perforated screw (1) to catch any fuel spills.

- ◆ Loosen the perforated screw (1) by approx. half a turn and wait a few seconds to allow the system to depressurize.
- ◆ Unscrew and remove the perforated screw (1) and take the two gaskets (2).

Perforated screw (1) driving torque: 22 Nm (2.2 kgm).

⚠ WARNING

Upon reassembly, change the two gaskets (2) and tighten the perforated screw (1) applying the prescribed torque in order to ensure perfect seal. This is essential, since the injection pressure is approx. 450 kPa (4.5 bar) and any fuel leakage would prove extremely dangerous, in fact the leaking fuel might end up on high-temperature parts of the engine.

When reassembling, a special seat (3) indicates the correct direction in which the pipe (4) must be placed.

The fuel delivery pipe (4) must not be entangled or positioned where it is likely to be squashed by other components; should it appear damaged or deteriorated, it must be replaced.

- ◆ Remove the tank completely.
- ◆ If the lower acoustic insulation edging at the front and lower antiheat edging at the rear prove damaged, replace them.

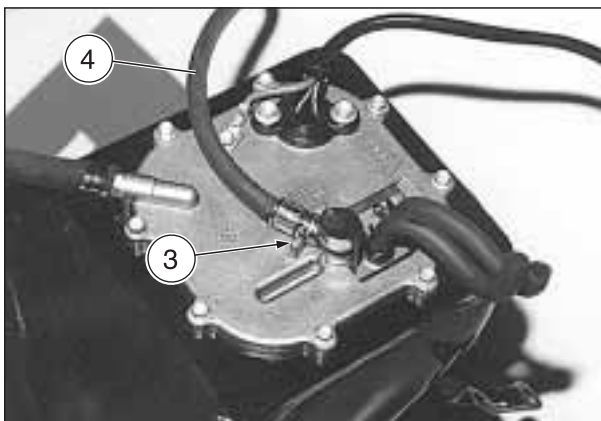
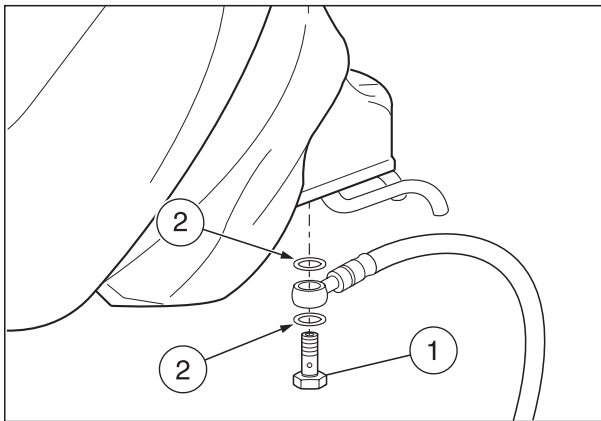

7.1.7 REMOVING THE AIR CLEANER CASE

Carefully read 0.5.1 (PRECAUTIONS AND GENERAL INFORMATIONS).

- ◆ Remove the air cleaner, see 2.10 (AIR CLEANER).
- ◆ Disconnect the pipe (1).
- ◆ Withdraw the suction pressure sensor (2) from its coupling.
- ◆ Unscrew and remove the six screws (3).

Screws (3) driving torque: 7 Nm (0.7 kgm).

⚠ CAUTION

For the removal of the air cleaner case (4) proceed with the greatest care, lifting it with slight movements.

- ◆ Raise and remove the air cleaner case (4).

⚠ CAUTION

Plug the openings with a clean cloth, to prevent any foreign matters from getting into the suction ducts.

Upon reassembly:

- Make sure that the O-ring is correctly positioned on the throttle body.
- The two conveyors (5) must be positioned correctly and adhere perfectly to the spongy material (6) around the front air intake holes.
- Before tightening the screws (3), make sure that the air cleaner case (4) rests completely on the throttle body.

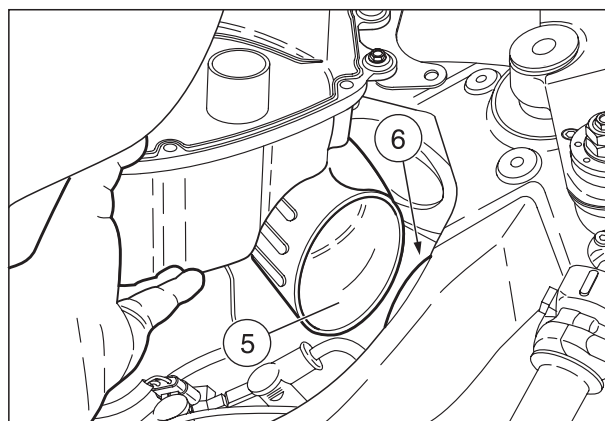
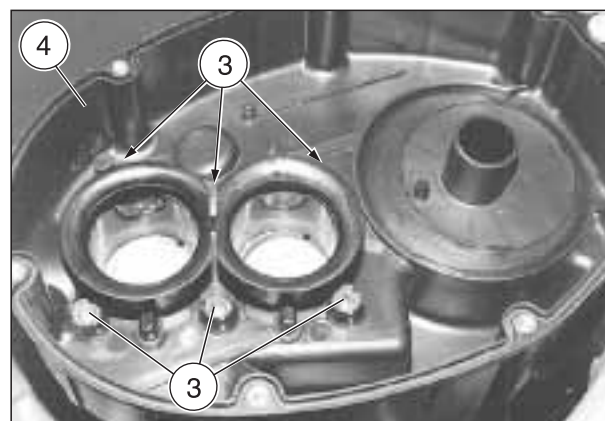
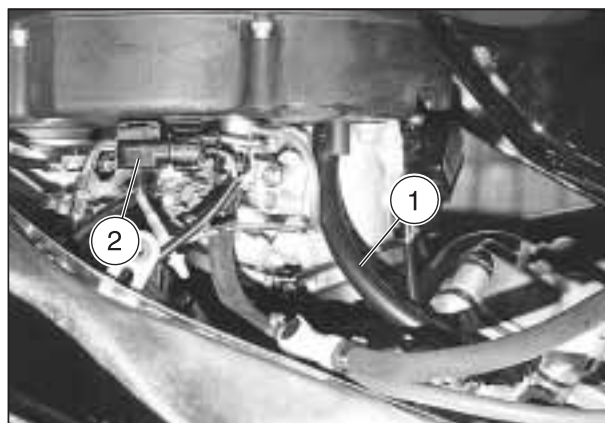

7.1.8 REMOVING THE BATTERY

Carefully read 0.5.1 (PRECAUTIONS AND GENERAL INFORMATIONS) and 2.4 (BATTERY).

NOTE To remove the battery it is necessary to set to zero the digital clock and the red line setting.

To reset these functions, see 2.3 (MULTIFUNCTION COMPUTER).

- ◆ Turn the ignition switch to position “1”.
- ◆ Put back the rider saddle, see 7.1.1 (REMOVING THE RIDER SADDLE).
- ◆ Unscrew and remove the screw (1) on the negative terminal (-).
- ◆ Move the negative cable (2) sideways.
- ◆ Remove the red protection element (3).
- ◆ Unscrew and remove the screw (4) on the positive terminal (+).
- ◆ Move the positive cable (5) sideways.
- ◆ Unscrew and remove the screw (6).

Screw (6) driving torque: 3 Nm (0.3 kgm).

- ◆ Remove the bracket (7) that locks the battery.

NOTE If the inner foam edging appears damaged, replace it.

- ◆ Grasp the battery (8) firmly and remove it from its compartment by lifting it.

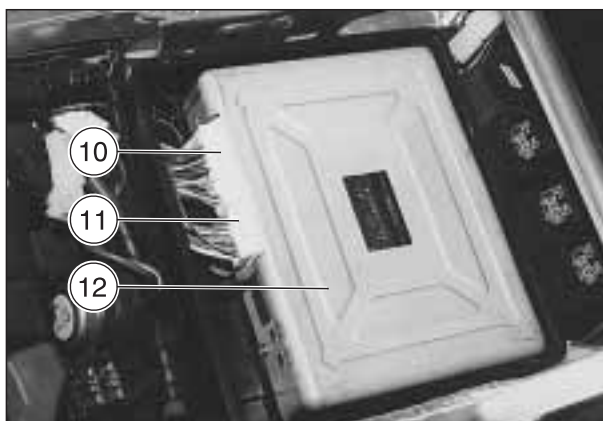
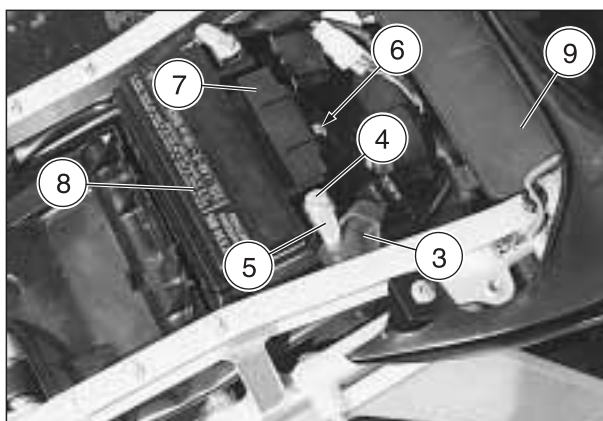
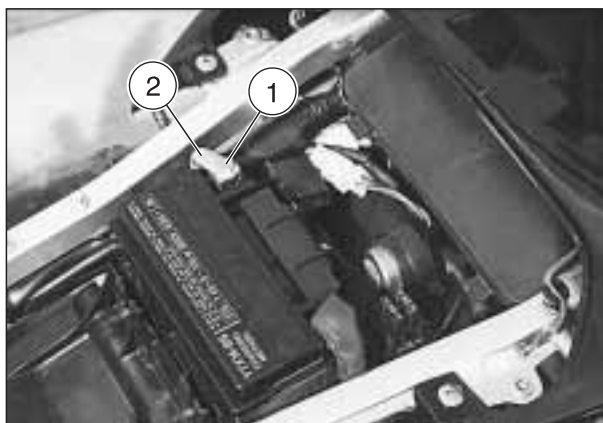

CAUTION

Upon reassembly, connect first the positive cable (+) and then the negative cable (-).

WARNING

Once it has been removed, the battery must be stored in a safe place and kept away from children.

- ◆ Position the battery on a flat surface, in a cool and dry place.

7.1.9 REMOVING THE ELECTRONIC UNIT

Carefully read 0.5.1 (PRECAUTIONS AND GENERAL INFORMATIONS).

- ◆ Turn the ignition switch to position “0”.
- ◆ Put back the rider saddle, see 7.1.1 (REMOVING THE RIDER SADDLE).
- ◆ Remove the upper protection element (9).
- ◆ Disconnect the two electric connectors (10) (11) from the electronic unit (12).

CAUTION

When reassembling, make sure the two electric connectors (10) (11) are plugged in properly.

- ◆ Remove the electronic unit (12), lifting it out of the compartment under the rider’s saddle.

7.1.10 REMOVING THE ANTIVIBRATION WEIGHT

Carefully read 0.5.1 (PRECAUTIONS AND GENERAL INFORMATIONS).

- ◆ Position the vehicle on the stand.
- ◆ Turn the ignition switch to position "⊗".
- ◆ Hold the antivibration weight (1) with an adjustable spanner with the jaws covered with adhesive tape in order not to damage it.

- ◆ Unscrew and remove the screw (2).

Screw (2) driving torque: 10 Nm (1.0 kgm).

- ◆ Remove the antivibration weight (1).
- ◆ Slide out the pin (3).
- ◆ Slide off the O-ring (4).
- ◆ Slide off the end piece (5).

End piece (5) driving torque: 35 Nm (3.5 kgm).

- ◆ Slide out the pin (6) and recover the rubber bush (7).

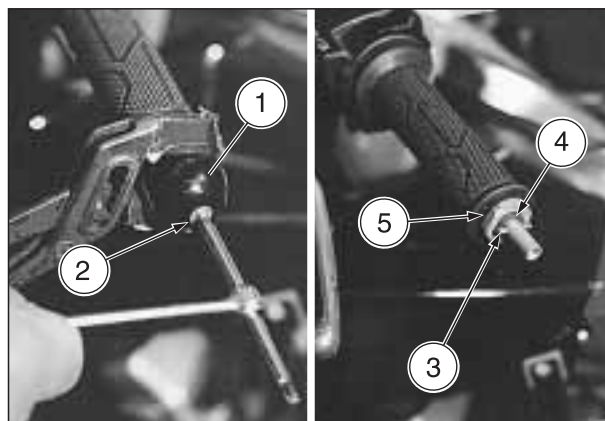

7.1.11 REMOVING THE COLD-START CONTROL

- ◆ Remove the grip from the left handlebar, see 7.1.12 (REMOVING THE GRIPS).
- ◆ Remove the electric controls, see 7.1.14 (REMOVING THE ELECTRIC CONTROLS ON THE LEFT HANDLEBAR).
- ◆ Unscrew and remove the two screws (8).
- ◆ Use a small flat-tip screwdriver to split open the cold-start control (9).
- ◆ Disconnect the cold-start cable.
- ◆ Slide off, holding the cold-start control components together.

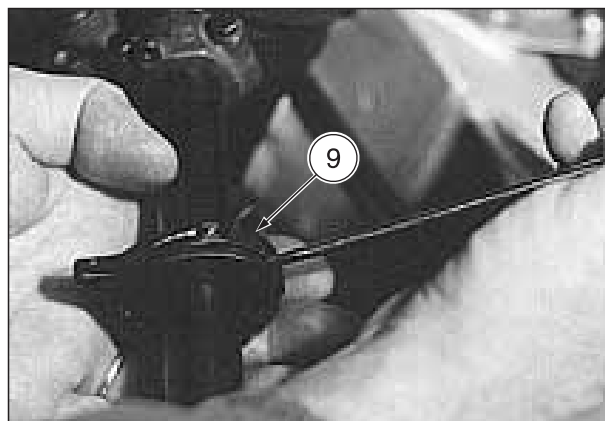
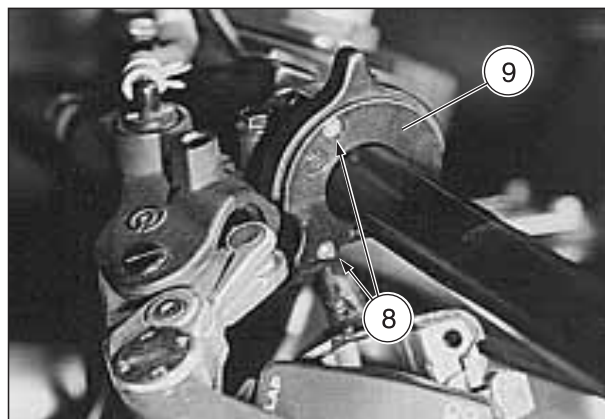
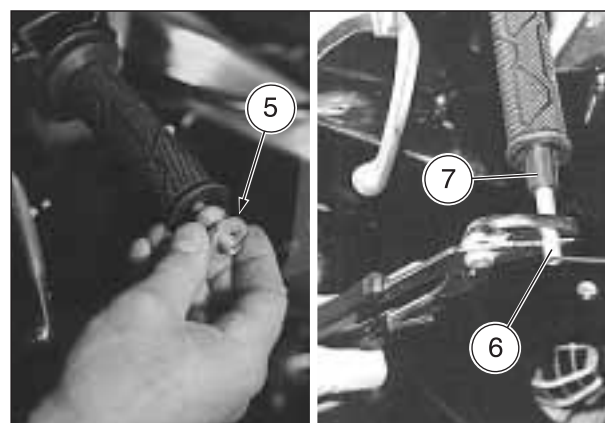

7.1.12 REMOVING THE GRIPS

Carefully read 0.5.1 (PRECAUTIONS AND GENERAL INFORMATIONS).

The operations indicated below refer ONLY to the grip of the left part of the handlebar (1).

⚠ WARNING

Any attempt to remove the accelerator control grip (2) following the operations indicated below would damage the accelerator control.

A damaged accelerator control may cause loss of control of the vehicle, with serious consequences for people, property and the vehicle itself.

When supplied as a spare part the accelerator control grip (2) comes with the accelerator control pipe (3) and therefore it must be removed together with the latter. For the removal, see 7.1.15 (REMOVING THE THROTTLE GRIP).

ONLY FOR THE LEFT HANDLEBAR GRIP (1):

- ◆ Remove the antivibration weight unit from the left part of the handlebar, see 7.1.10 (REMOVING THE ANTIVIBRATION WEIGHT).
- ◆ Insert the nozzle of a compressed air gun between the grip (1) and handlebar.
- ◆ Blow air, moving the gun's nozzle with a rotary movement and, at the same time, seize the other grip (1) with the other hand and slide it off.
- ◆ Check the conditions of the two O-rings (4) and if they are damaged replace them.

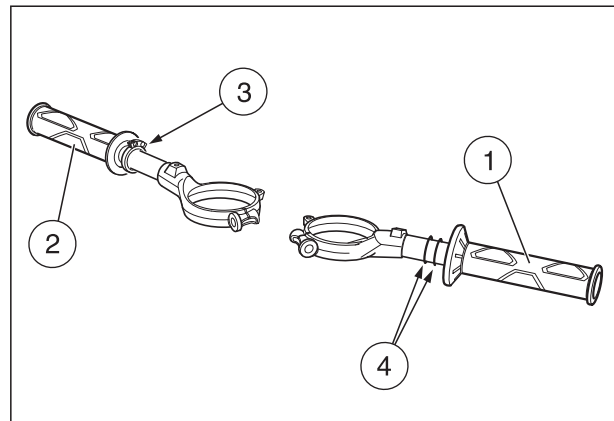

7.1.13 REMOVING THE CLUTCH LEVER

Carefully read 0.5.1 (PRECAUTIONS AND GENERAL INFORMATIONS).

- ◆ Position the vehicle on the side stand.
- ◆ Turn the ignition switch to position "OFF".
- ◆ Remove the cold-start control, see 7.1.11 (REMOVING THE COLD-START CONTROL).

COMPLETE REMOVAL

- ◆ Drain the clutch control system, see 7.1.55 (DRAINING THE CLUTCH CONTROL SYSTEM).
- ◆ Unscrew and remove the clutch control lever connection screw (1) and take the two sealing washers (2).

Clutch control lever connection screw (1) driving torque: 20 Nm (2.0 kgm).

⚠ CAUTION

Upon reassembly, replace the two sealing washers with two new washers of the same type.

- ◆ Put a nylon bag on the coupling (3) and fix it to the clutch pipe with adhesive tape.
- ◆ Use a small Phillips screwdriver to prise the clutch switch (7) from the two slots on the clutch lever.
- ◆ Unscrew and remove the tank support screw (5).

Driving torque of the tank support screw (5): 10 Nm (1.0 kgm).

NOTE Before removing the U bolt (6), mark its position on the handlebar so it can be refitted in the right place.

- ◆ Unscrew and remove the two U bolt screws (7).

U bolt screws driving torque (7): 8 Nm (0.8 kgm).

- ◆ Remove the U bolt (6).

NOTE When refitting, the U bolt (6) must be positioned with the arrow inscribed on the top facing forwards (direction of travel).

- ◆ Remove the clutch control (8) complete with the clutch fluid reservoir (9).

PARTIAL REMOVAL

- ◆ Unscrew and remove the tank support screw (5).

Driving torque of the tank support screw (5): 10 Nm (1.0 kgm).

NOTE Before removing the U bolt (6), mark its position on the handlebar so it can be refitted in the right place.

- ◆ Unscrew and remove the two U bolt screws (7).

U bolt screws driving torque (7): 8 Nm (0.8 kgm).

- ◆ Remove the U bolt (6).

NOTE When refitting, the U bolt (6) must be positioned with the arrow inscribed on the top facing forwards (direction of travel).

Follow ►

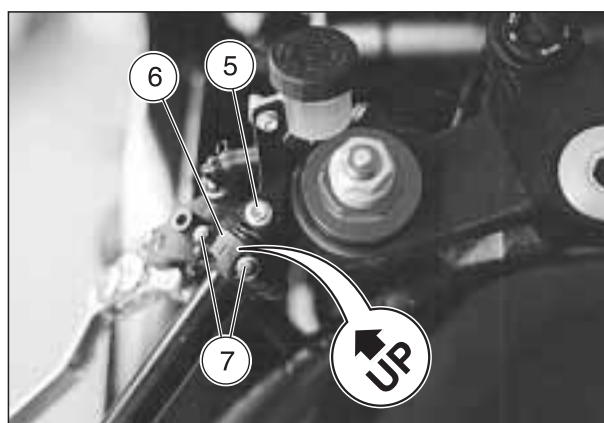
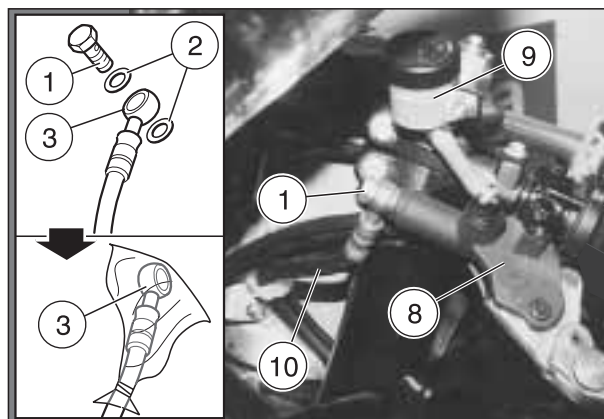

Follow ►

The following remain connected to the clutch control (8):

- the clutch fluid reservoir (9);
- the clutch fluid pipe (10);
- the clutch switch (4) with the corresponding cable (11).

CAUTION

Do not force pipes and cables.
To avoid dangerous clutch fluid leakages, keep the clutch reservoir (9) in operating position (vertical).

- ◆ Partially remove the clutch control (8).

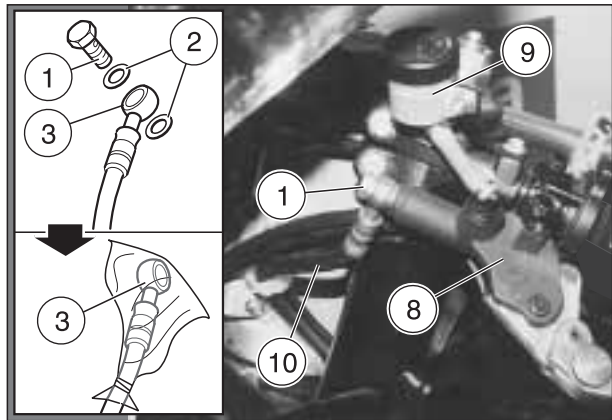

7.1.14 REMOVING THE ELECTRIC CONTROLS ON THE LEFT HANDLEBAR

Carefully read 0.5.1 (PRECAUTIONS AND GENERAL INFORMATIONS).

- ◆ Position the vehicle on the stand.
- ◆ Turn the ignition switch to position "OFF".
- ◆ Unscrew and remove the two screws (12) fastening the two halves of the casing (13) (14) at the bottom.
- ◆ Split the two halves of the casing (13) (14) apart.

CAUTION

When reassembling, first set the lower half of the casing (13) in place, making sure the special locating dowel enters the relevant hole on the handlebar.

- ◆ Free the cabling from the three clamps (15) (16) (17).

NOTE Prepare the same number of clamps, which will be required for reassembly.

- ◆ Lift the protection element (18).
- ◆ Disconnect the left-hand dip switch electric connector (19).

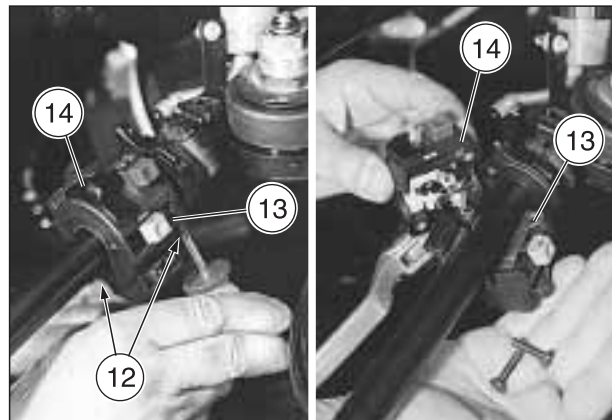

CAUTION

When reassembling, make sure the connector (19) is plugged in properly and that the protection element (18) has been refitted in the right position.

- ◆ Remove the two halves of the casing (13) (14).

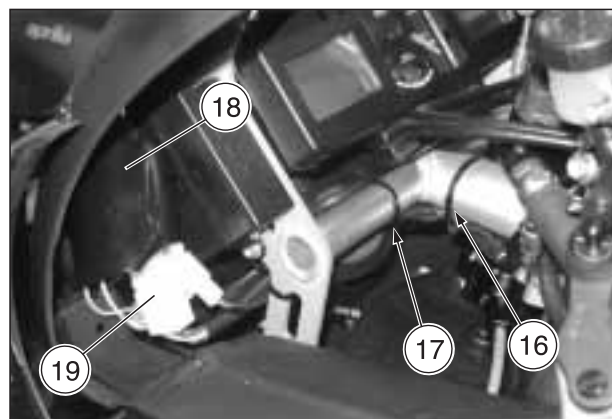

7.1.15 REMOVING THE THROTTLE GRIP

Carefully read 0.5.1 (PRECAUTIONS AND GENERAL INFORMATIONS).

- ◆ Remove the antivibration weight unit from the right handlebar, see 7.1.10 (REMOVING THE ANTIVIBRATION WEIGHT).
- ◆ Unscrew and remove the two screws (1).
- ◆ Remove the rear half of the throttle control casing (2).
- ◆ Remove the air filter casing, see 7.1.7 (REMOVING THE AIR CLEANER CASE).
- ◆ Loosen the lock nut (3).
- ◆ Release the throttle cable adjuster (4) from the relevant coupling.
- ◆ Disconnect the throttle cable.
- ◆ Repeat the last three operations for the other throttle cable.

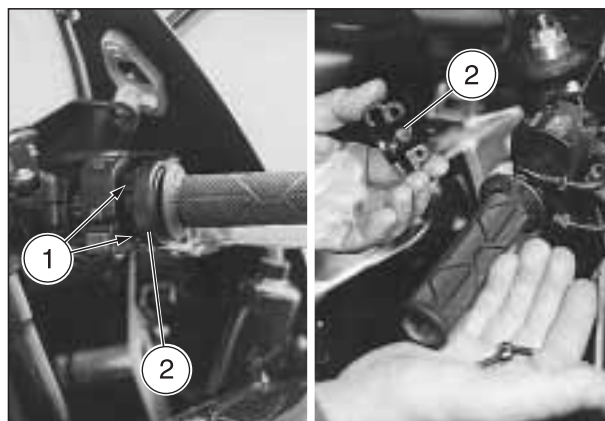

⚠ CAUTION

Upon reassembly, make sure that the two accelerator cable adjusters are properly fastened to the corresponding couplings; check and if necessary restore the correct slack, see 2.11.3 (ADJUSTING THE ACCELERATOR CONTROL).

- ◆ Move the half-casing of the throttle control (5) and disconnect the two throttle cables.
- ◆ Slide off the throttle grip (6).

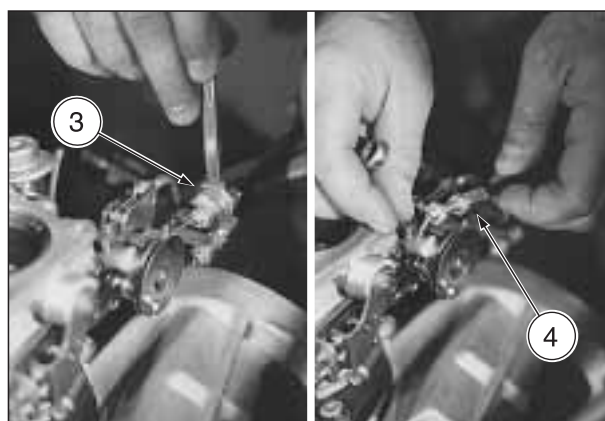

7.1.16 REMOVING THE FRONT BRAKE LEVER

Carefully read 0.5.1 (PRECAUTIONS AND GENERAL INFORMATIONS).

- ◆ Position the vehicle on the stand.
- ◆ Turn the ignition switch to position "⊗".

COMPLETE REMOVAL

- ◆ Drain the front braking system, see 7.5.7 (DRAINING THE BRAKING SYSTEMS).
- ◆ Unscrew and remove the front brake lever connection screw (7) and take the two sealing washers (8).

Front brake lever connection screw (7) driving torque: 20 Nm (2.0 kgm).

⚠ CAUTION

Upon reassembly, replace the two sealing washers with two new washers of the same type.

- ◆ Put a nylon bag on the connection (9) and seal it with adhesive tape.

Follow ►

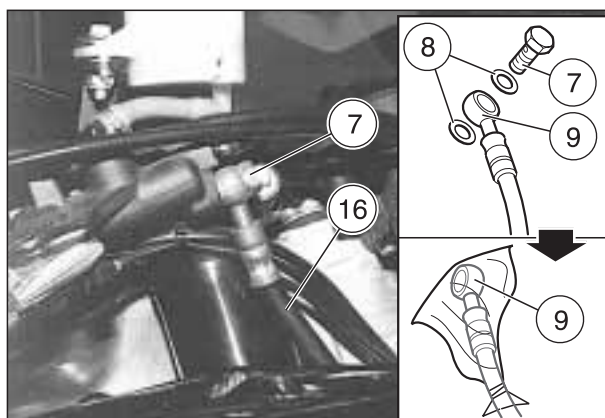
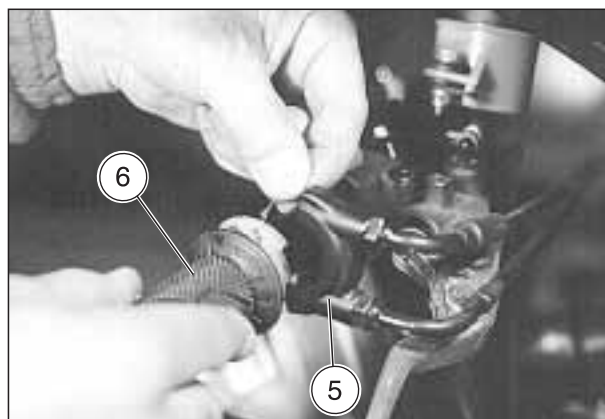

Follow ►

- ◆ Using a small flat-tip screwdriver, lift the stop light switch (10) and remove it from the two seats on the front brake control.
- ◆ Unscrew and remove the tank support screw (11).

Driving torque of the tank support screw (11): 10 Nm (1.0 kgm).

NOTE Before removing the U bolt (12), mark its position on the handlebar so it can be refitted in the right place.

- ◆ Unscrew and remove the two U bolt screws (13).

U bolt screw driving torque (13): 3 Nm (0.3 kgm).

- ◆ Remove the U bolt (12).

NOTE When refitting, the U bolt (12) must be positioned with the arrow inscribed on the top facing forwards (direction of travel).

- ◆ Remove the front brake control (14) complete with front brake reservoir (15).

PARTIAL REMOVAL

- ◆ Unscrew and remove the tank support screw (11).

Driving torque of the tank support screw (11): 10 Nm (1.0 kgm).

NOTE Before removing the U bolt (12), mark its position on the handlebar so it can be refitted in the right place.

- ◆ Unscrew and remove the two U bolt screws (13).

U bolt screws driving torque (13): 3 Nm (0.3 kgm).

- ◆ Remove the U bolt (12).

NOTE When refitting, the U bolt (12) must be positioned with the arrow inscribed on the top facing forwards (direction of travel).

The following elements remain connected to the front brake control (14):

- the front brake fluid tank (15);
- front brake fluid pipe (16);
- the stop light switch (10) with the corresponding cable (17).

⚠ CAUTION

Do not force pipes and cables.
To avoid dangerous brake fluid leakages, keep the front brake reservoir (15) in operating position (vertical).

- ◆ Partially remove the front brake lever (14).

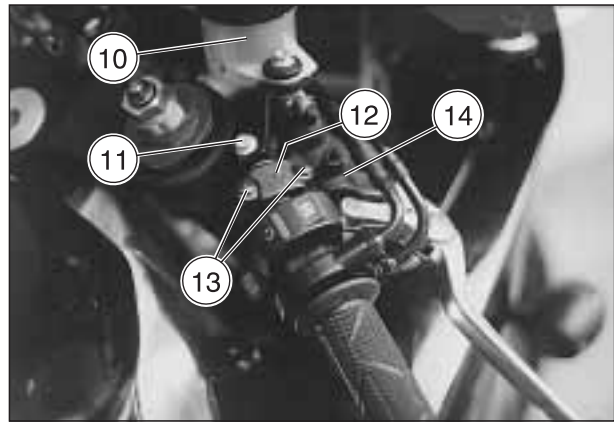

7.1.17 REMOVING THE ELECTRIC CONTROLS ON THE RIGHT HANDLEBAR

Carefully read 0.5.1 (PRECAUTIONS AND GENERAL INFORMATIONS).

- ◆ Position the vehicle on the stand.
- ◆ Turn the ignition switch to position "OFF".
- ◆ Lift the protection element (1).
- ◆ Disconnect the right dip switch electric connector (2).

⚠ CAUTION

When reassembling, make sure the connector (2) is plugged in properly and that the protection element (1) has been refitted in the right position.

- ◆ Free the cabling from the three clamps (3) (4) (5).

NOTE Prepare the same number of clamps, which will be required for reassembly.

- ◆ Unscrew and remove the two screws (6) (7) fastening the two halves of the casing (8) (9) at the bottom.

NOTE When reassembling, the shorter of the two screws (6) must be positioned at the front.

- ◆ Split the two halves of the casing (8) (9) apart and remove them.

⚠ CAUTION

When reassembling, first set the lower half of the casing (9) in place, making sure the special locating dowel enters the relevant hole on the handlebar.

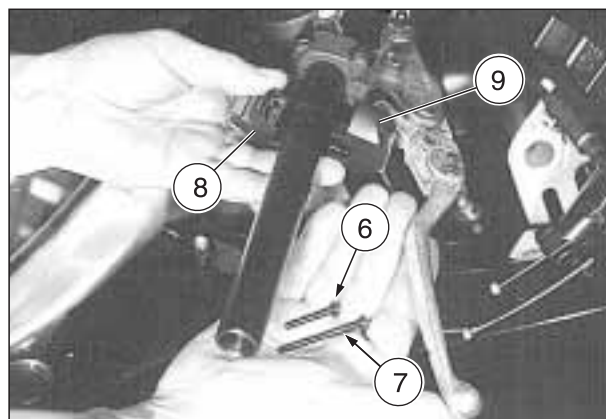
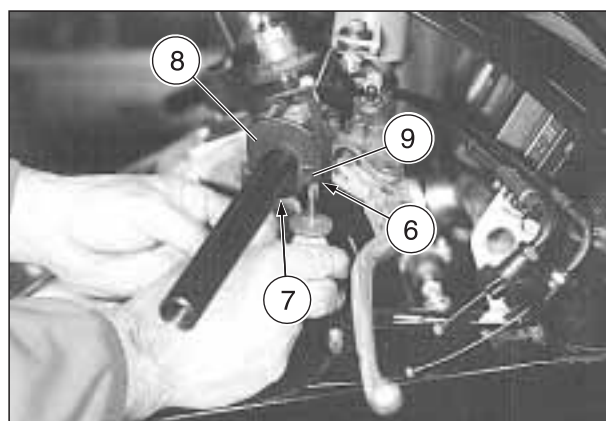
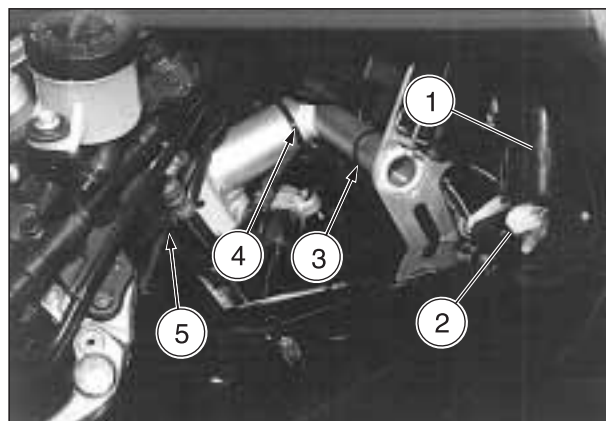

7.1.18 REMOVING THE IGNITION SWITCH/ STEERING LOCK

Carefully read 0.5.1 (PRECAUTIONS AND GENERAL INFORMATIONS).

- ◆ Position the vehicle on the stand.
- ◆ Turn the steering all the way over to the left.
- ◆ Turn the ignition switch to position "OFF".
- ◆ Release the wiring from the two fastening clamps (1) (2).

NOTE Prepare the same number of clamps, which will be required for reassembly.

- ◆ Lift the protection element (3).
- ◆ Disconnect the electric connector (4).

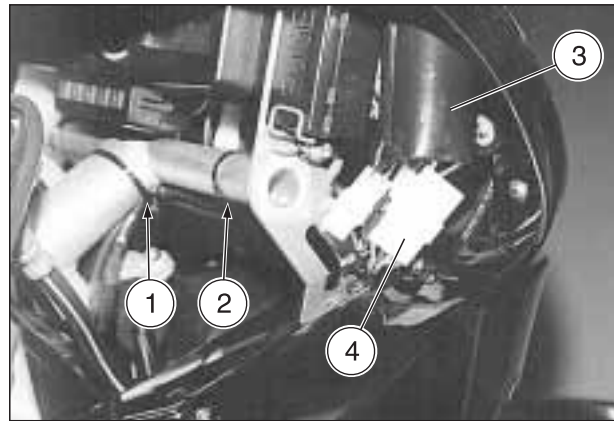

CAUTION

When reassembling, make sure the connector is plugged in properly.

- ◆ Unscrew and remove the screw (5) and take the bushing.

NOTE When reassembling, position the cable guide (6) correctly.

- ◆ Use a chisel to cut into the head of the special screw (7) and turn it until it loosens.
- ◆ Unscrew the screw (7) by hand and remove it.

NOTE When reassembling, use another screw of the same type, tightening it until the head comes off.

- ◆ Remove the ignition switch/steering lock (8), sliding it out from underneath.

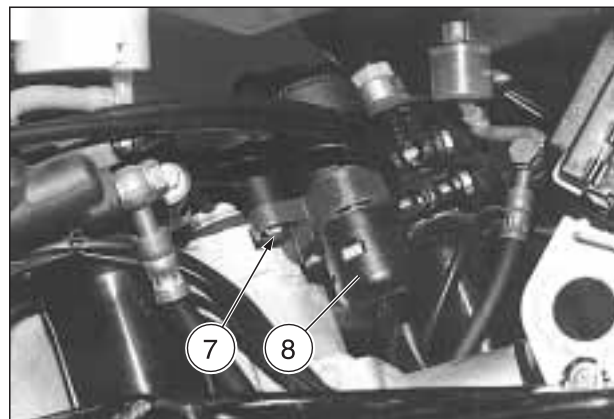
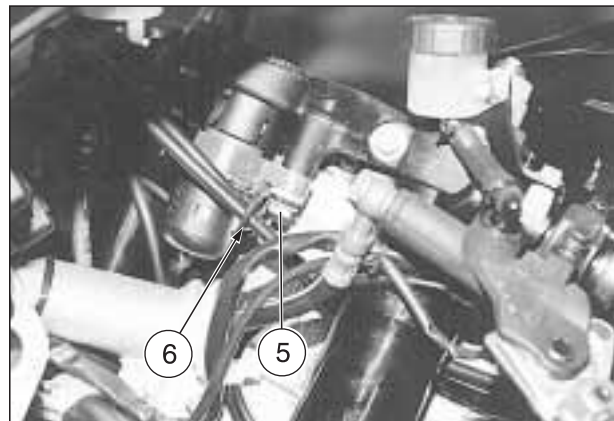

7.1.19 REMOVING THE FORK UPPER PLATE

Carefully read 0.5.1 (PRECAUTIONS AND GENERAL INFORMATIONS).

For the complete removal only:

- ◆ Remove the ignition switch/steering lock, see 7.1.18 (REMOVING THE IGNITION SWITCH/STEERING LOCK).

For the partial removal:

CAUTION

At the end of the operations described, the plate remains connected to the ignition switch/steering lock. Do not force the electric cables.

NOTE The following procedure does not necessarily have to be performed with the front fairing removed, though it is advisable to remove it in order to gain more room for manoeuvre, see 7.1.22 (REMOVING THE FRONT PART OF THE FAIRING).

Screw (1) driving torque: 10 Nm (1.0 kgm).

- ◆ ★ Unscrew and remove the screw (1) securing the handlebar (2) to the upper plate (3).

NOTE The clutch fluid reservoir (4) and the front brake reservoir (5) hinder the withdrawal of the fork upper plate. For this reason, it is necessary to release them from the respective fastenings to the handlebar.

Screw (7) driving torque: 10 Nm (1.0 kgm).

- ◆ Unscrew and remove the screw (7) fastening the clutch fluid tank.

Screw (6) driving torque: 10 Nm (1.0 kgm).

- ◆ Unscrew and remove the screw (6) fastening the front brakefluid tank (5).

NOTE Loosen ONLY the screw (8) that fastens the upper plate (3).

Do not loosen the screw (9) that locks the handlebar half (3).

Screw (8) driving torque: 25 Nm (2.5 kgm).

- ◆ ★ Loosen the screw (8) that fastens the upper plate (3) to the front fork (10).

Upper plug driving torque (11): 100 Nm (10.0 kgm).

- ◆ Unscrew and remove the upper plug (11), retrieving the relevant washer.

CAUTION

Carry out the following operations with care, in order to avoid damaging the clutch fluid reservoir (4), the front brake reservoir (5), the cables of the ignition switch/steering lock.

Any damage to these components may cause loss of control of the vehicle, with serious consequences for people, property and the vehicle itself.

Follow ►

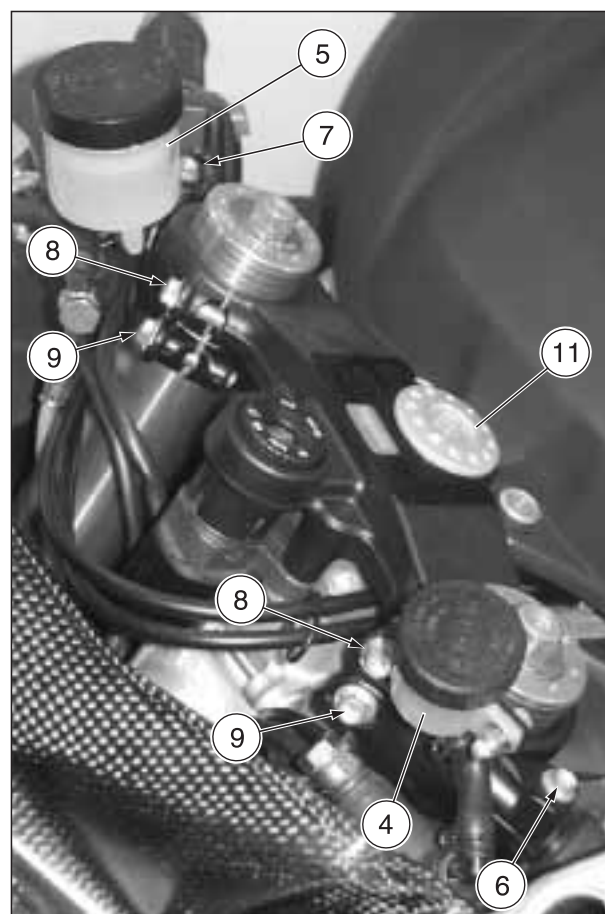
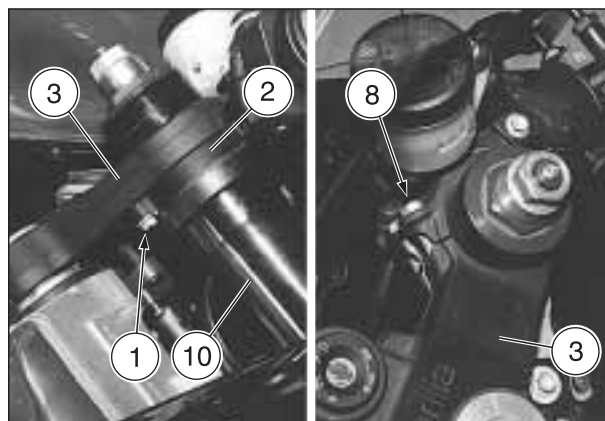

Follow ►

NOTE Upon reassembly, position the upper plate manually, and fit it without using any tool.

- ◆ Using a plastic hammer, tap the upper plate (3), complete with ignition switch/steering lock, from underneath until it is pushed off upwards.
- ◆ Bend the upper plate (3) over forwards, placing a cloth between it and the dashboard to avoid damage.

Upon reassembly:

- ◆ Refit the upper plate (3), making sure it is correctly housed.
- ◆ Lubricate the thread and base on which the bush rests using motor oil, see 1.6 (LUBRICANT CHART).

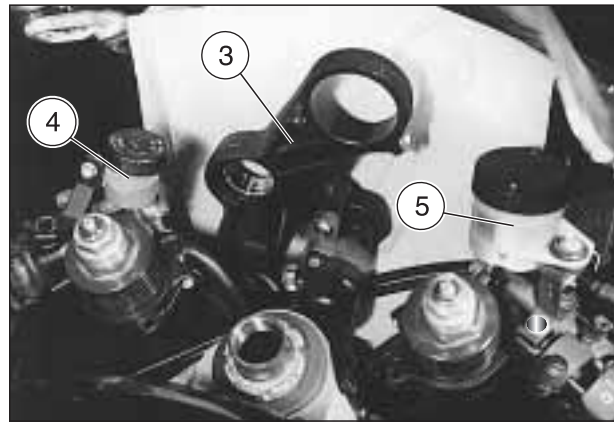

7.1.20 REMOVING THE RIGHT AND LEFT HANDLEBARS

According to the need, it is possible to remove the two halves of the handlebar “partially” (removed from the sliders, but complete with some components and still connected to the vehicle) or “completely” (entirely removed, without any component attached to them).

NOTE Before proceeding, decide if you want to carry out a “partial” or “complete” removal. For the “partial” removal, DO NOT carry out the operations marked with the symbol “✱”.

Left handlebar:

- ◆ Remove the clutch control, see 7.1.13 (REMOVING THE CLUTCH LEVER).
- ◆ ✱ Remove the cold-start control, see 7.1.11 (REMOVING THE COLD-START CONTROL).

Right handlebar:

- ◆ Remove the front brake lever, see 7.1.16 (REMOVING THE FRONT BRAKE LEVER).
- ◆ ✱ Remove the throttle grip, see 7.1.15 (REMOVING THE THROTTLE GRIP).
- ◆ ✱ Remove the electric controls on the right handlebar, see 7.1.17 (REMOVING THE ELECTRIC CONTROLS ON THE RIGHT HANDLEBAR).

The following information refers to one of the two halves of the handlebar, but is valid for both.

Handlebar half fastening screw driving torque (12): 25 Nm (2.5 kgm).

- ◆ Loosen the handlebar half fastening screw (12).
- ◆ Partially remove the fork upper plate (3), see 7.1.19 (REMOVING THE FORK UPPER PLATE).
- ◆ Withdraw the handlebar half from the slider.

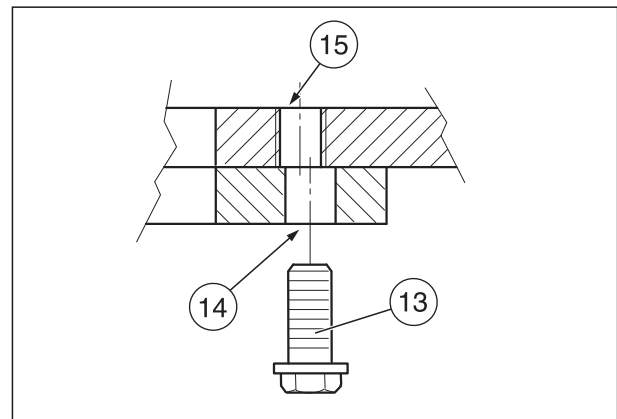
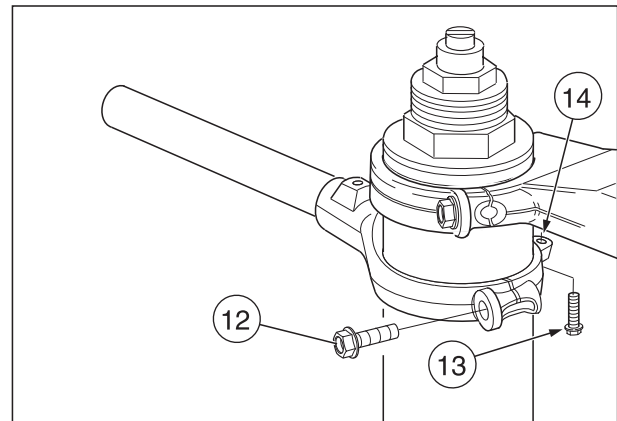

misaligned and the screw (13) could not be screwed in or would be screwed in incorrectly.

CAUTION
 For the “partial” removal only. Other components remain connected to the two halves of the handlebar. When withdrawing the two halves of the handlebar from the sliders, proceed with care and avoid forcing tubes, cables or wires.

Upon reassembly:

NOTE Screw and tighten the handlebar half fastening screw (12) ONLY AFTER tightening the screw (13) that fastens the handlebar half to the fork upper plate. Otherwise, the hole (14) on the handlebar half and the corresponding thread (15) on the fork upper plate may be

7.1.21 REMOVING THE REAR-VIEW MIRRORS

- ◆ Unscrew and remove the nut (1), take the washer (2), the spring (3) and the half sphere (4).

Nut (1) driving torque: 8 Nm (0.8 kgm).

⚠ CAUTION

Handle the plastic and painted components with care to avoid scraping or damaging them.

- ◆ Remove the rear-view mirror (5).
- ◆ If it has gone out of its seat, take the cup (6).

NOTE Repeat these operations to remove the other rear-view mirror.

⚠ CAUTION

After reassembly, correctly adjust the rear-view mirrors and tighten the nuts in such a way as to ensure their stability.

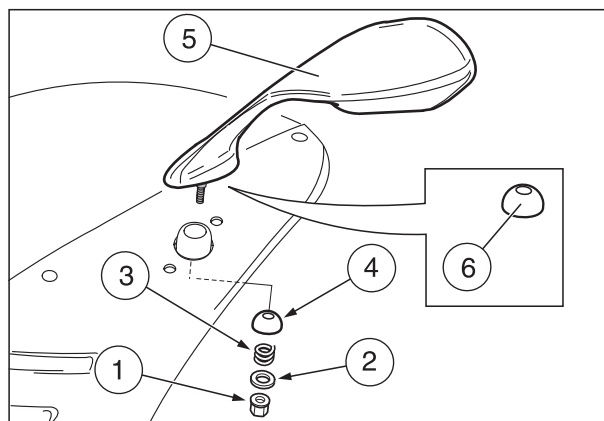
**7.1.22 REMOVING THE FRONT PART OF THE FAIRING**

- ◆ Position the vehicle on the stand.
- ◆ Turn the ignition switch to position "OFF".
- ◆ Unscrew and remove the two lower screws (7).

Screws (7) driving torque: 4 Nm (0.4 kgm).

- ◆ ★ Unscrew and remove the side screw (8).

Screw (8) driving torque: 4 Nm (0.4 kgm).

⚠ CAUTION

Upon reassembly, tighten the screw (8) applying the prescribed torque, since it is fixed on plastic.

- ◆ ★ Unscrew and remove the two upper screws (9).

Screws (9) driving torque: 5 Nm (0.5 kgm).

NOTE Upon reassembly, rotate the rear-view mirror support so that the fastening holes coincide with those provided on the front part of the fairing.

The whole unit must be correctly positioned on the support.

- ◆ Move the front part of the fairing (10) slightly forward.
- ◆ Raise the protection element (11).
- ◆ Disconnect the electric connector (12) of the headlight.

⚠ CAUTION

Upon reassembly, make sure that the electric connector (12) is correctly coupled.

Handle the plastic and painted components with care to avoid scraping or damaging them.

- ◆ Remove the front part of the fairing (10) completely, together with the headlight and the rear-view mirrors.
- ◆ Where necessary, remove the headlight, see 7.1.23 (REMOVING THE HEADLIGHT) and rearview mirrors, see 7.1.21 (REMOVING THE REAR-VIEW MIRRORS).

After reassembly:

- ◆ Adjust the inclination of the rear-view mirrors correctly.

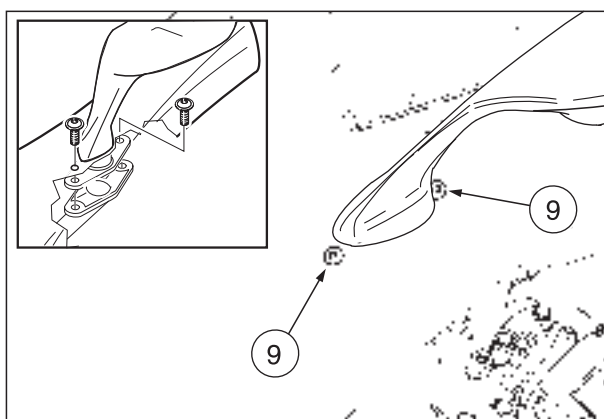
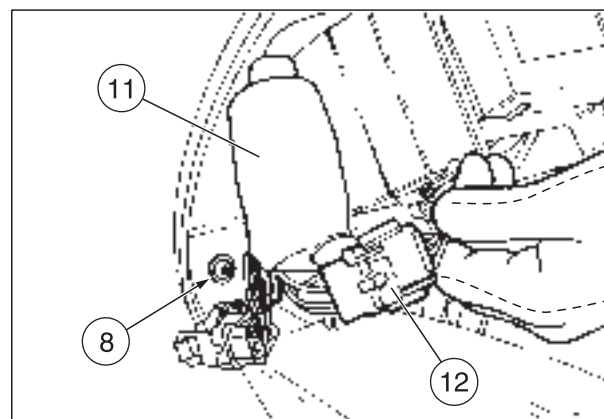
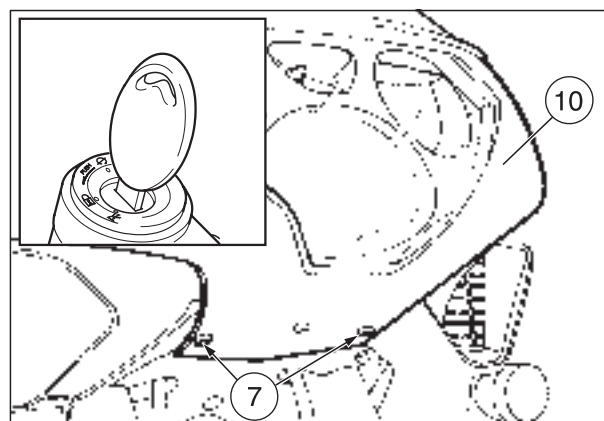

7.1.23 REMOVING THE HEADLIGHT

Carefully read 0.5.1 (PRECAUTIONS AND GENERAL INFORMATIONS).

- ◆ Remove the front part of the fairing, see 7.1.22 (REMOVING THE FRONT PART OF THE FAIRING).
- ◆ Unscrew and remove the screw (1).

Screw (1) driving torque: 4 Nm (0.4 kgm).

- ◆ Unscrew and remove the three screws (2) and retrieve the three washers.

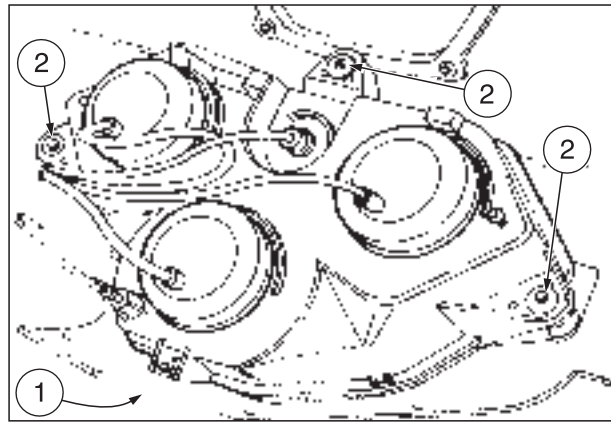

CAUTION

Handle the transparent part with care to avoid scraping or damaging it.

- ◆ Remove the headlight.

7.1.24 REMOVING THE DASHBOARD'S UPPER PROTECTION MOULDING

- ◆ Remove the front part of the fairing, see 7.1.22 (REMOVING THE FRONT PART OF THE FAIRING).
- ◆ ★ Unscrew and remove the two fastening screws (3).

Screws (3) driving torque: 2 Nm (0.2 kgm).

- ◆ Remove the protection moulding (4), sliding it out from the back.

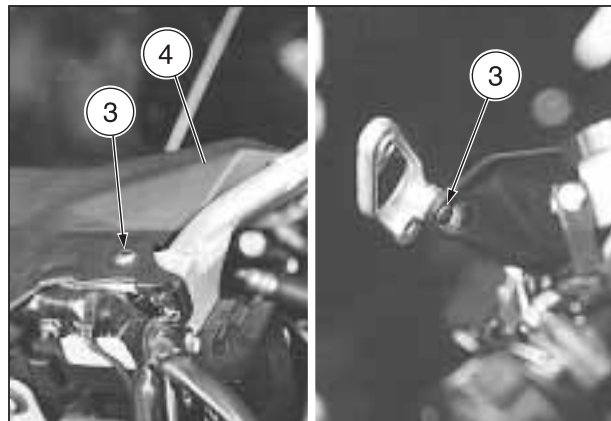

7.1.25 REMOVING THE DASHBOARD

Carefully read 0.5.1 (PRECAUTIONS AND GENERAL INFORMATIONS).

- ◆ Remove the front part of the fairing, see 7.1.22 (REMOVING THE FRONT PART OF THE FAIRING).
- ◆ Slip off the protection element (5).
- ◆ Withdraw the electric connector (6).

CAUTION

Upon reassembly, make sure that the electric connector (6) is correctly coupled.

- ◆ Loosen and remove the three nuts (7).

Nuts (7) driving torque: 5 Nm (0.5 kgm).

- ◆ Remove the dashboard (8).

NOTE If the rubber elements are damaged, change them.

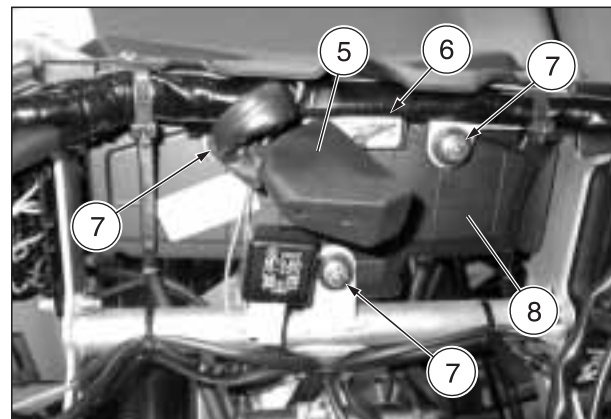

7.1.26 REMOVING THE DASHBOARD/FRONT FAIRING MOUNT

Carefully read 0.5.1 (PRECAUTIONS AND GENERAL INFORMATIONS).

- ◆ Remove the dashboard's upper protection moulding, see 7.1.24 (REMOVING THE DASHBOARD'S UPPER PROTECTION MOULDING).
- ◆ Remove the dashboard, see 7.1.25 (REMOVING THE DASHBOARD).
- ◆ Remove the steering shock absorber, see 7.7.6 (REMOVING THE STEERING SHOCK ABSORBER).
- ◆ Remove the air conveyor covers, see 7.1.31 (REMOVING THE AIR CONVEYOR COVERS).
- ◆ Slide the blinker (1) from the relevant coupling.
- ◆ Unscrew and remove the two screws (2) and retrieve the safety clip (3).
- ◆ Move the secondary fuse box (4) over to the side.
- ◆ Unscrew and remove the two screws (5).

Screws (5) driving torque: 3 Nm (0.3 kgm).

- ◆ Move the relay box (6) over to the side.
- ◆ Open the collar (7) and release the clutch fluid pipe and the cold start cable.

⚠ CAUTION

When reassembling, refit the pipe and cable inside the collar (7).

- ◆ Release the wiring from the two special clamps (8).
- ◆ Release the wiring from the clamps (9) and (10).

NOTE Prepare the same number of clamps, which will be required for reassembly.

- ◆ Unscrew and remove the two nuts (11).

Nuts (11) driving torque: 12 Nm (1.2 kgm).

- ◆ Unscrew and remove the two screws (12).
- ◆ Remove the dashboard /front fairing mount (13) by lifting it out.

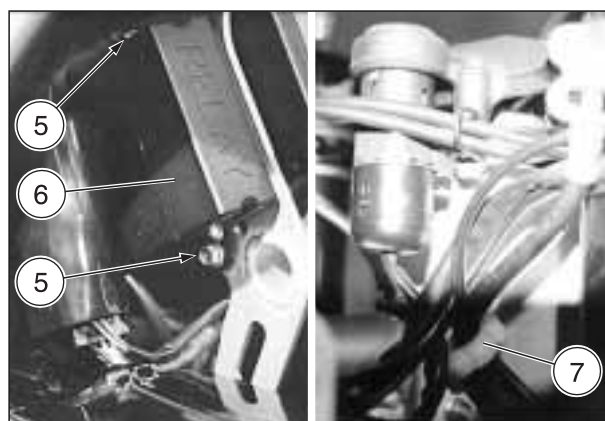
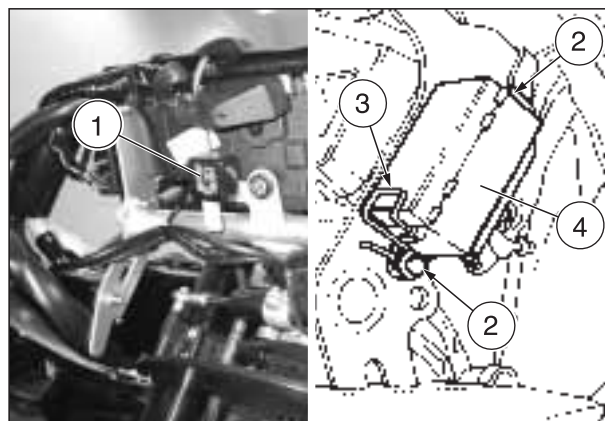

7.1.27 REMOVING THE FRONT MUDGUARD

Carefully read 0.5.1 (PRECAUTIONS AND GENERAL INFORMATIONS).

- ◆ Position the vehicle on the stand.
- ◆ ★ Unscrew and remove the two screws (14).

Screws (14) driving torque: 5 Nm (0.5 kgm).

⚠ CAUTION

Handle the plastic and painted components with care to avoid scraping or damaging them.

- ◆ Pull the mudguard (15) out from the front.

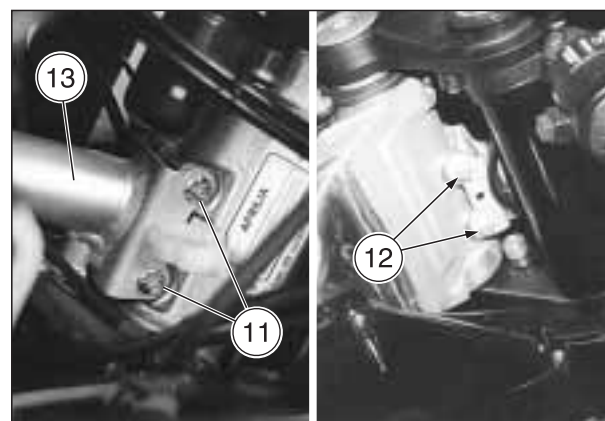
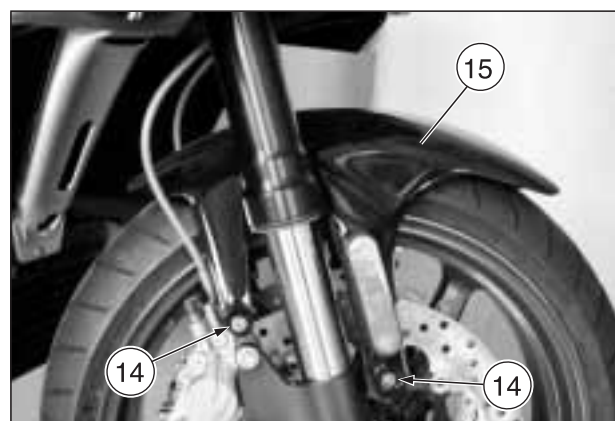
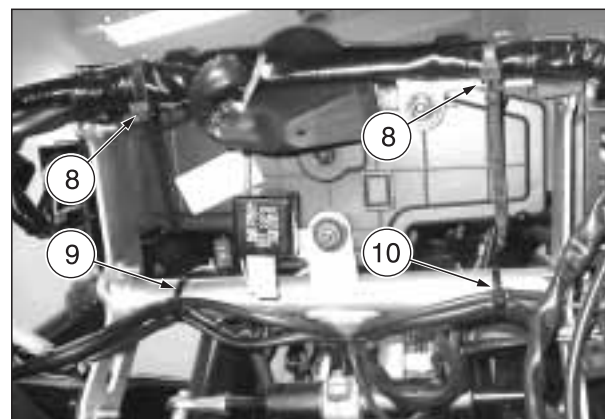

7.1.28 REMOVING THE SIDE FAIRINGS

CAUTION

Wait until the engine and the exhaust silencer have completely cooled down.

- ◆ Position the vehicle on the stand.
- ◆ Rotate the six rapid fastening screws (1) by giving them 1/4 turn anticlockwise.

CAUTION

Handle the plastic and painted components with care to avoid scraping or damaging them.

- ◆ Remove the side fairing (2).
- ◆ If the inner acoustic insulation edging proves damaged, replace it.

NOTE Repeat these operations to remove the other side fairing.

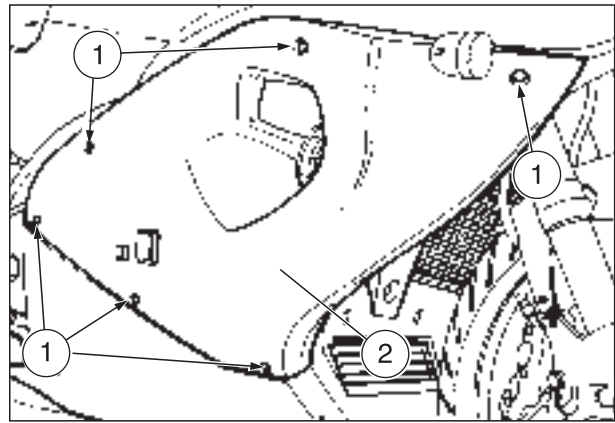

7.1.29 REMOVING THE SIDE FAIRING UPPER PANELS

- ◆ Position the vehicle on the stand.
- ◆ Unscrew and remove the screw (3).

Screw (3) driving torque: 1 Nm (0.1 kgm).

- ◆ Unscrew and remove the screw (4).

Screw (4) driving torque: 2 Nm (0.2 kgm).

CAUTION

Handle the plastic and painted components with care to avoid scraping or damaging them.

- ◆ Lift and remove the panel (5).

NOTE Where necessary, repeat the procedure to remove the other panel.

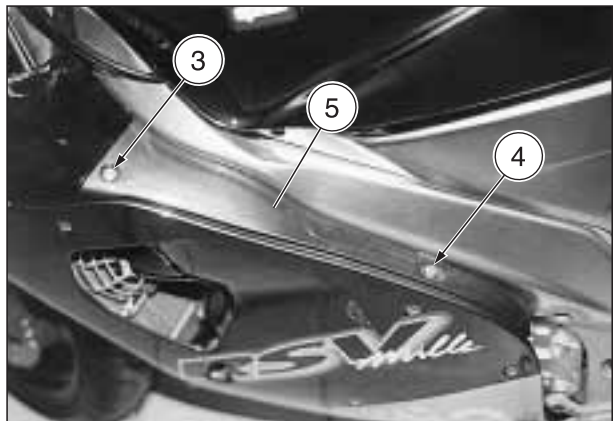

7.1.30 REMOVING THE FRONT DIRECTION INDICATORS

Carefully read 0.5.1 (PRECAUTIONS AND GENERAL INFORMATIONS).

- ◆ Remove the cover of the relevant air conveyor, see 7.1.31 (REMOVING THE AIR CONVEYOR COVERS).
- ◆ Loosen and remove the nut (6).
- ◆ Slide out the screw (7).
- ◆ Remove the direction indicator (8).

CAUTION

When removing the direction indicator (8), help the electric cable, complete with connector, through the relevant slot to be found on the air conveyor cover (9).

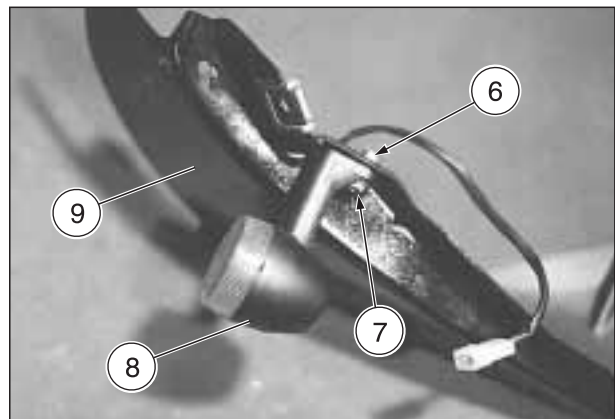

7.1.31 REMOVING THE AIR CONVEYOR COVERS

Carefully read 0.5.1 (PRECAUTIONS AND GENERAL INFORMATIONS).

- ◆ Turn the ignition switch to position "⊗".
- ◆ Remove the side fairing, see 7.1.28 (REMOVING THE SIDE FAIRINGS).
- ◆ Remove the left fairing upper panel, see 7.1.29 (REMOVING THE SIDE FAIRING UPPER PANELS).
- ◆ Unscrew and remove the seven fastening screws (1).

NOTE The air conveyor cover remains connected to the vehicle by means of the electric connector cable (3) of the front direction indicator. To reach and disconnect the electric connector (3), it is necessary to partially remove the air conveyor cover.

⚠ CAUTION

Handle the plastic and painted components with care to avoid scraping or damaging them.

⚠ CAUTION

Do not force the electric cables and the electric connector (3).

- ◆ Partially remove the air conveyor cover, see (2).
- ◆ Disconnect the front indicator electric connector (3).

⚠ CAUTION

When reassembling, make sure the electric connector (3) is plugged in properly and that the cable is refitted in the appropriate seat.

- ◆ Remove the air conveyor cover (2), complete with front direction indicator (4).
- ◆ Where necessary, remove the front indicator (4), see 7.1.30 (REMOVING THE FRONT DIRECTION INDICATORS).

NOTE Where necessary, repeat the procedure to remove the other air conveyor cover.

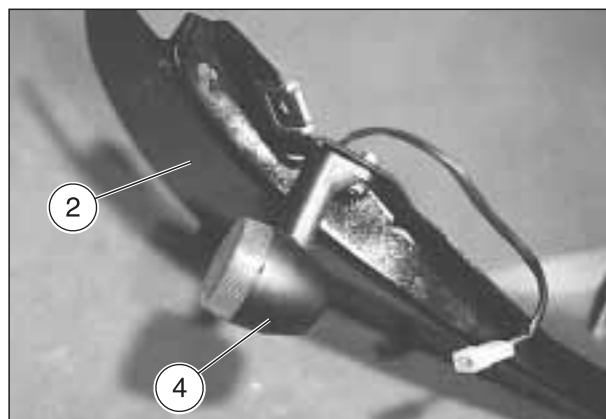
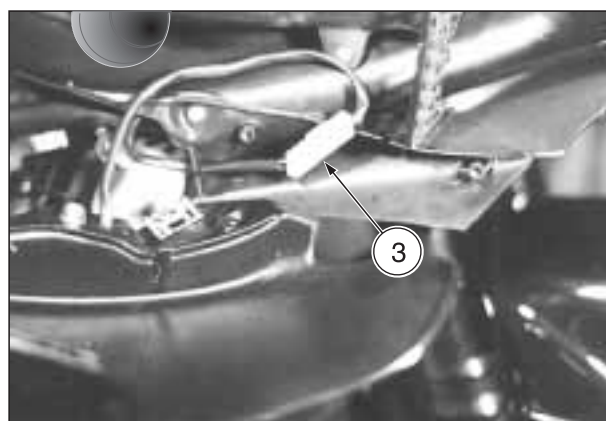
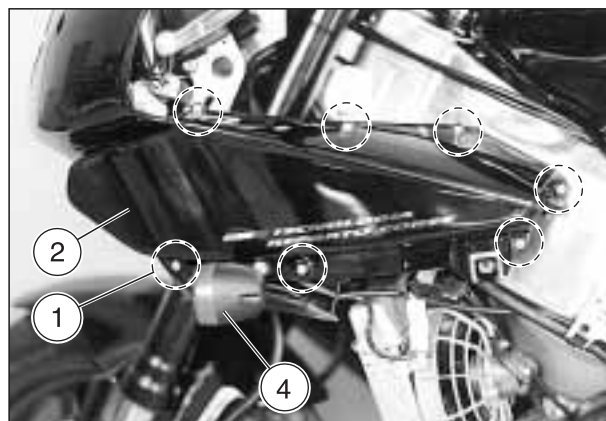

7.1.32 REMOVING THE FRONT FAIRING LOWER LOCKUP

Carefully read 0.5.1 (PRECAUTIONS AND GENERAL INFORMATIONS).

- ◆ Position the vehicle on the stand.
- ◆ Unscrew and remove the three screws (5).

⚠ CAUTION

Take care not to damage the brake fluid pipes. Nudge the front fairing lower lockup (6) along gradually to determine the best position for sliding it out.

- ◆ Remove the front fairing lower lockup (6).

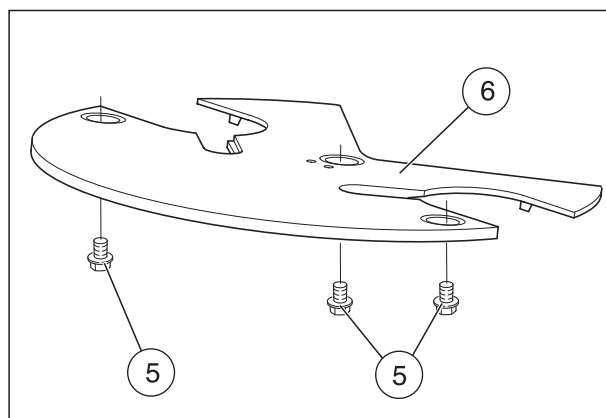

7.1.33 REMOVING THE AIR CONVEYOR

Carefully read 0.5.1 (PRECAUTIONS AND GENERAL INFORMATIONS).

- ◆ Remove the air conveyor cover, see 7.1.31 (REMOVING THE AIR CONVEYOR COVERS).
- ◆ Disconnect the electric connector (2) from the air thermistor (1) (on left side of vehicle only).

CAUTION

When reassembling, make sure the electric connector (2) is plugged in properly and that the cable is refitted in the appropriate seat.

- ◆ Slide the cable of the air thermistor (1) from the seats (on left side of vehicle only).
- ◆ Unscrew and remove the upper fastening screw (3).

Screw (3) driving torque: 4 Nm (0.4 kgm).

CAUTION

Upon reassembly, tighten the screw (3) applying the prescribed torque, since it is fixed on plastic.

- ◆ Unscrew and remove the lower fastening screw (4).

Screw (4) driving torque: 4 Nm (0.4 kgm).

- ◆ Unscrew and remove the front fastening screw (5).

Screw (5) driving torque: 5 Nm (0.5 kgm).

- ◆ Unscrew and remove the two rear fastening screws (6).

Screws (6) driving torque: 5 Nm (0.5 kgm).

- ◆ Partially remove the air conveyor case (7).
- ◆ Open the collar (8) and release the electric wiring.

CAUTION

When reassembling, refit the electric wiring inside the collar (8).

- ◆ Remove the air conveyor case (7) completely.
- ◆ On left side of vehicle only; where necessary, unscrew and remove the screw (9) and slide out the grating (10) complete with air thermistor (1).

NOTE Where necessary, repeat the procedure to remove the other air conveyor case.

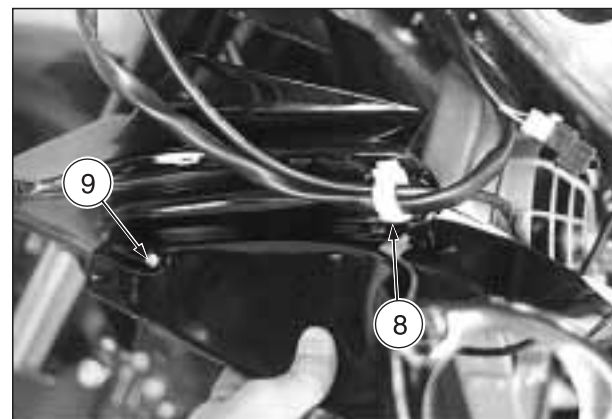
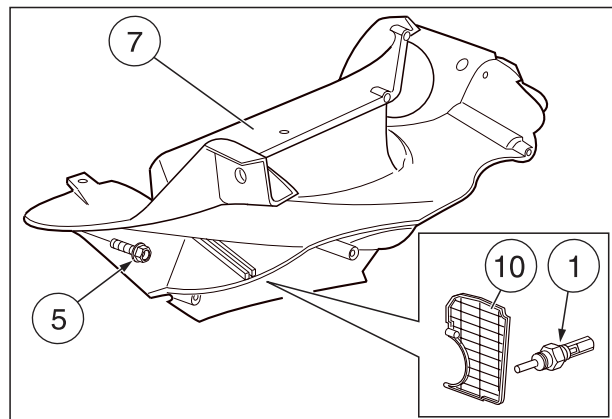
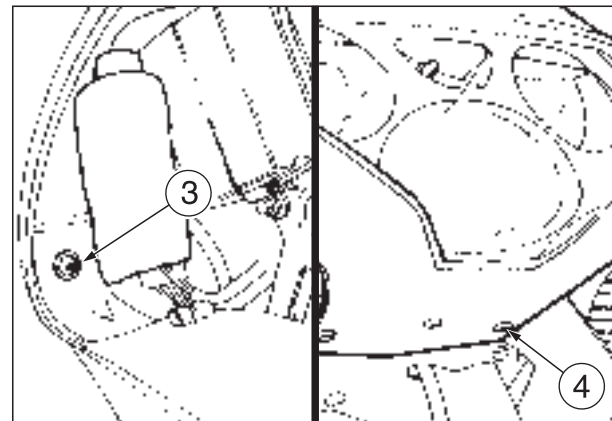
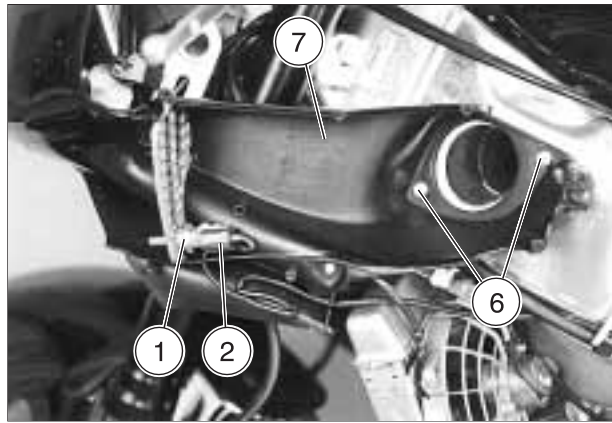

7.1.34 REMOVING THE LOWER FAIRING

Carefully read 0.5.1 (PRECAUTIONS AND GENERAL INFORMATIONS).

- ◆ Position the vehicle on the appropriate rear support stand, see 1.8.2 (POSITIONING THE VEHICLE ON THE REAR SUPPORT STAND **OPT**).

⚠ CAUTION

Wait until the engine and the exhaust silencer have completely cooled down.

- ◆ Remove the two side fairings, see 7.1.28 (REMOVING THE SIDE FAIRINGS).
- ◆ Unscrew and remove the two front fastening screws (1).

Screws (1) driving torque: 5 Nm (0.5 kgm).

- ◆ ★ Unscrew and remove the rear screw (2).

Screws (2) driving torque: 5 Nm (0.5 kgm).

- ◆ Unscrew and remove the two screws (3) of the rear right profile (4) (inside the exhaust silencer).

Screws (3) driving torque: 5 Nm (0.5 kgm).

⚠ CAUTION

Handle the plastic and painted components with care to avoid scraping or damaging them.

- ◆ Let the side stand down.
- ◆ Withdraw the two pipes (5) (6) from the hole provided on the fairing.
- ◆ Remove the entire lower fairing (7) by lowering it and with small movements try to find the best position to withdraw it from the side stand.

NOTE Upon reassembly, introduce the two pipes (5) (6) in the hole provided on the fairing.

- ◆ Take the rear right profile (4).

NOTE Upon reassembly, the upper part of the profile (4) must be fitted between the lower fairing (7) and the support plate.

- ◆ If the inner acoustic insulation edging proves damaged, replace it.
- ◆ Where necessary, disassemble the lower fairing (7) into three parts (left, right, front) after removing the stop rings (8), sliding out the respective pins (9) and retrieving the washers (10).

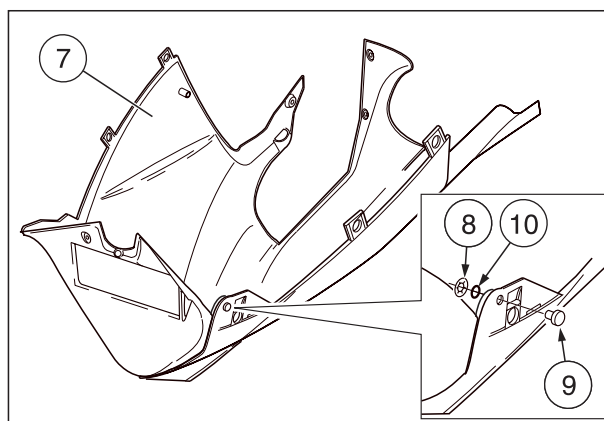
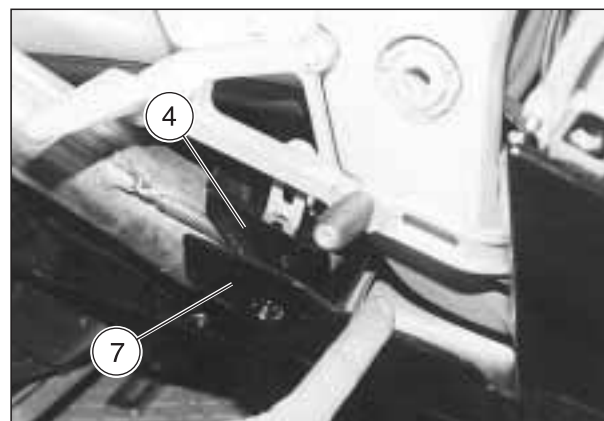
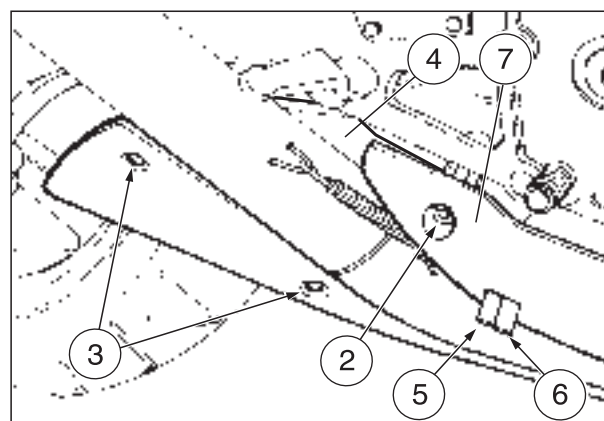
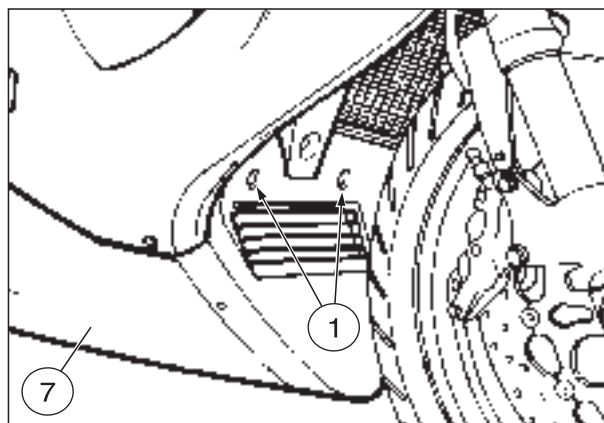

7.1.35 REMOVING THE RADIATOR SPOILER

Carefully read 0.5.1 (PRECAUTIONS AND GENERAL INFORMATIONS).

- ◆ Position the vehicle on the stand.

⚠ WARNING

Wait until the engine and the exhaust silencer have completely cooled down.

- ◆ Unscrew and remove the two upper fastening screws (1).

Screws (1) driving torque: 4 Nm (0.4 kgm).

- ◆ Unscrew and remove the two screws (2) fastening the front of the lower fairing (3).

Screws (2) driving torque: 5 Nm (0.5 kgm).

- ◆ Remove the the lower fairing, see 7.1.34 (REMOVING THE LOWER FAIRING).
- ◆ Unscrew and remove the lower fastening screw (4).

Screw (4) driving torque: 4 Nm (0.4 kgm).

⚠ CAUTION

Handle the plastic and painted components with care to avoid scraping or damaging them.

- ◆ Move the radiator spoiler (5) forwards and slide it out from the bottom.
- ◆ If the inner antiheat edging proves damaged, replace it.

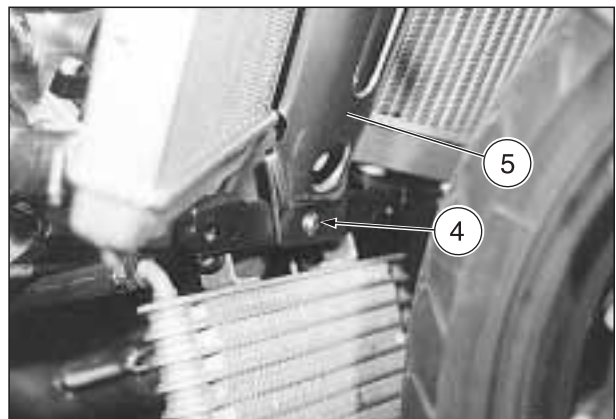
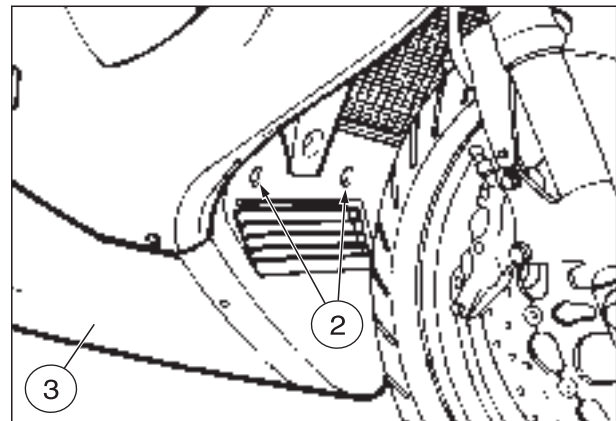
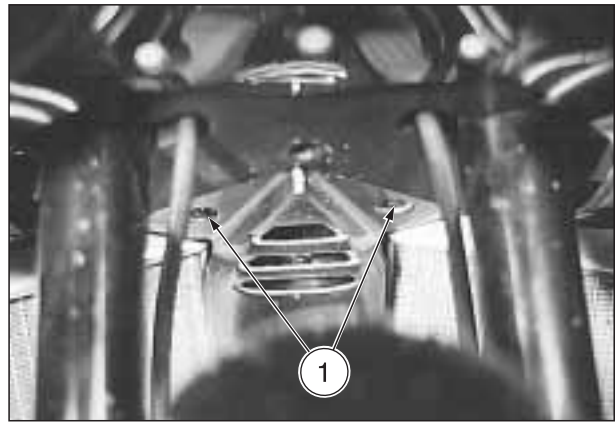

7.1.36 REMOVING THE REAR FAIRING REAR END

Carefully read 0.5.1 (PRECAUTIONS AND GENERAL INFORMATIONS).

- ◆ Turn the ignition switch to position "OFF".
- ◆ Remove the passenger seat, see 7.1.2 (UNLOCKING/LOCKING THE PASSENGER SEAT).
- ◆ Disconnect the rear light electric connector (1).

⚠ CAUTION

Upon reassembly, make sure that the electric connector (1) is correctly coupled.

- ◆ Unscrew and remove the two upper fastening screws (2).

Screws (2) driving torque: 5 Nm (0.5 kgm).

- ◆ Unscrew and remove the two lower fastening screws (3).

Screws (3) driving torque: 3 Nm (0.3 kgm).

⚠ CAUTION

Handle the plastic and painted components with care to avoid scraping or damaging them.

- ◆ Remove the end of the rear part of the fairing (4), complete with rear light (5).

7.1.37 REMOVING THE REAR LIGHT

- ◆ Remove the rear fairing rear end (4), see 7.1.36 (REMOVING THE REAR FAIRING REAR END).
- ◆ Unscrew and remove the two screws (6) and retrieve the two washers.

⚠ CAUTION

Handle the transparent part with care to avoid scraping or damaging it.

- ◆ Remove the rear light (5).

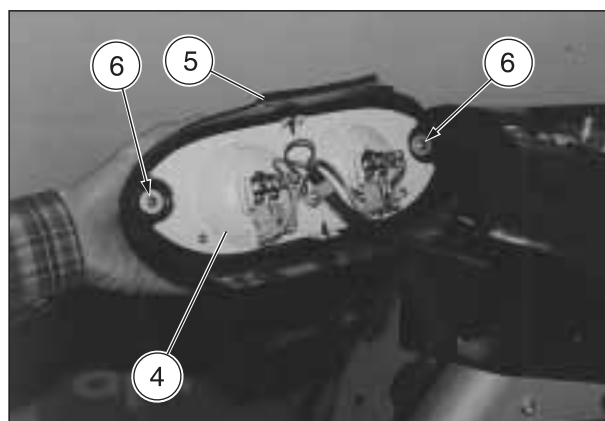
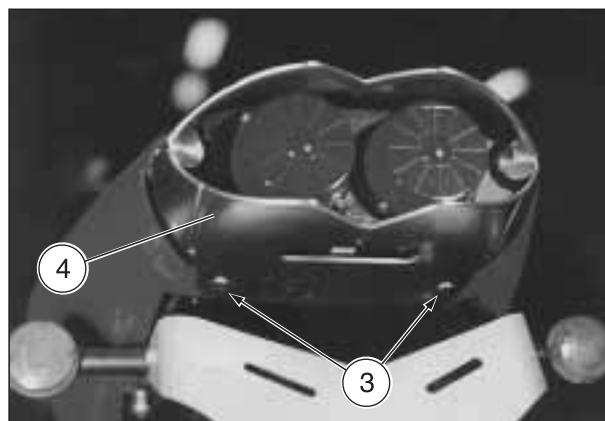
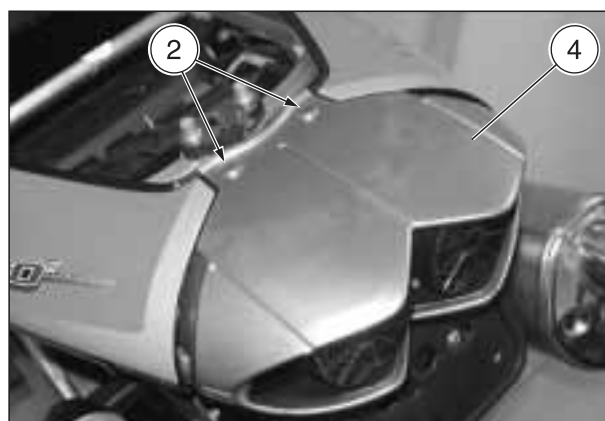

7.1.38 REMOVING THE REAR FAIRING

Carefully read 0.5.1 (PRECAUTIONS AND GENERAL INFORMATIONS).

CAUTION

Wait until the engine and the exhaust silencer have completely cooled down.

- ◆ Put back the rider saddle, see 7.1.1 (REMOVING THE RIDER SADDLE).
- ◆ Remove the rear fairing rear end, see 7.1.36 (REMOVING THE REAR FAIRING REAR END).
- ◆ ★ Unscrew and remove the passenger grab strap fastening screw (1).

Screw (1) driving torque: 10 Nm (1.0 kgm).

- ◆ Retrieve the grab strap (2).
- ◆ Unscrew and remove the two front fastening screws (3).

Screws (3) driving torque: 2 Nm (0.2 kgm).

- ◆ ★ Unscrew and remove the two lower fastening screws (4).

Screws (4) driving torque: 2 Nm (0.2 kgm).

CAUTION

Handle the plastic and painted components with care to avoid scraping or damaging them.

- ◆ Prise the front part of the rear fairing (5) slightly apart and slide it off the back.

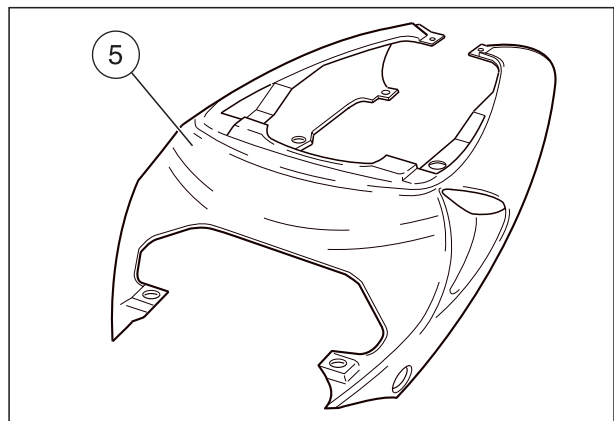
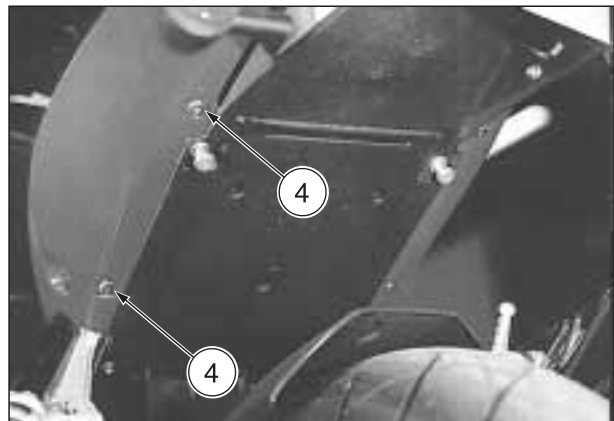
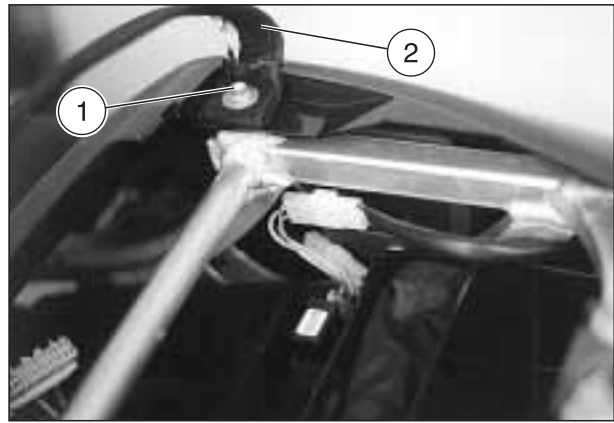

7.1.39 REMOVING THE PASSENGER SEAT LOCK

Carefully read 0.5.1 (PRECAUTIONS AND GENERAL INFORMATIONS).

- ◆ Remove the rear fairing, see 7.1.38 (REMOVING THE REAR FAIRING).
- ◆ Unscrew and remove the two fastening screws (1) securing the key-operated control (2).

Screws (1) driving torque: 12 Nm (1.2 kgm).

- ◆ Unscrew and remove the two fastening screws (3) securing the lock (4) and retrieve the two bushes.

Screws (3) driving torque: 10 Nm (1.0 kgm).

- ◆ Remove the lock unit complete with key-operated control (2) + wire (5) + lock (4).

⚠ CAUTION

When reassembling, make sure the wire (5) is positioned correctly and is not twisted.

- ◆ Retrieve the bracket (6) supporting the rear light and rear fairing.

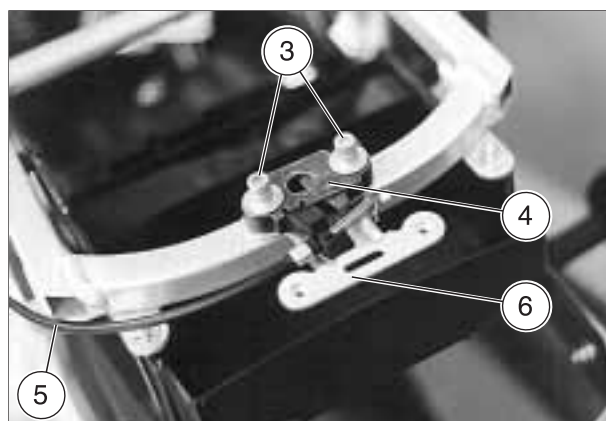
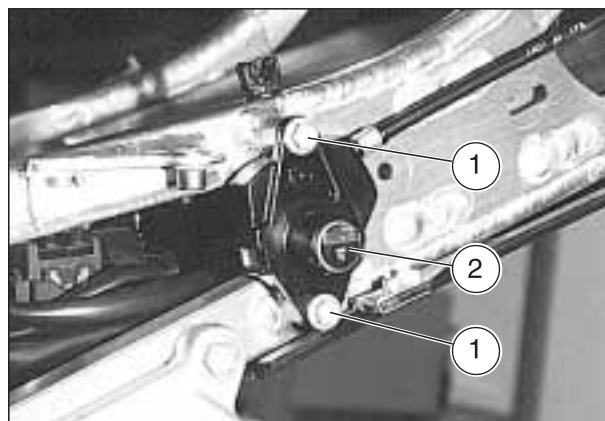

7.1.40 REMOVING THE REAR DIRECTION INDICATORS

Carefully read 0.5.1 (PRECAUTIONS AND GENERAL INFORMATIONS).

- ◆ Remove the passenger seat, see 7.1.2 (UNLOCKING/ LOCKING THE PASSENGER SEAT).
- ◆ Turn the ignition switch to position "⊗".
- ◆ Disconnect the electric connector (7).

⚠ CAUTION

Upon reassembly, make sure that the electric connector (7) is correctly coupled.

- ◆ Loosen and remove the nut (8).

Nut (8) driving torque: 2 Nm (0.2 kgm).

- ◆ Unscrew and remove the screw (9).
- ◆ Loosen and remove the nut (10).

Nut (10) driving torque: 2 Nm (0.2 kgm).

- ◆ Unscrew and remove the screw (11).
- ◆ Remove the direction indicator (12).

⚠ CAUTION

When removing the direction indicator (12), help the electric cable, complete with relevant connector, through the special slots to be found on the saddle support lower moulded cover and on the number plate holder.

NOTE Where necessary, repeat the procedure to remove the other direction indicator.

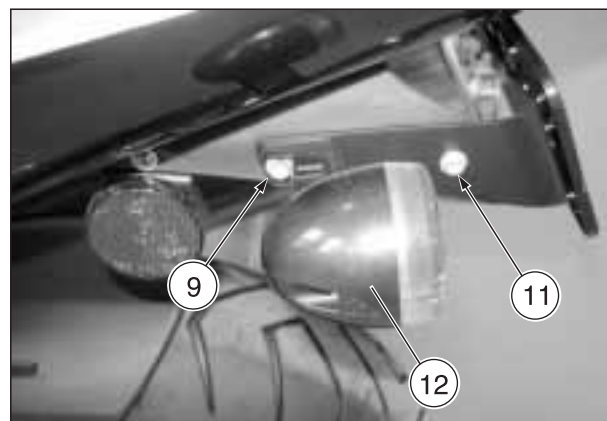
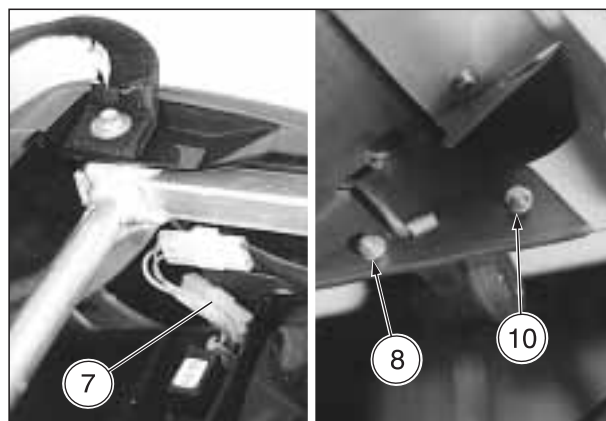

7.1.41 REMOVING THE SADDLE SUPPORT LOWER MOULDED COVER

Carefully read 0.5.1 (PRECAUTIONS AND GENERAL INFORMATIONS).

- ◆ Remove the rear fairing, see 7.1.38 (REMOVING THE REAR FAIRING).
- ◆ Remove the fuel tank, see 7.1.5 (PARTIAL REMOVAL OF THE FUEL TANK).
- ◆ Remove the tools supplied and any other objects from the glove compartment.
- ◆ Remove the battery, see 7.1.8 (REMOVING THE BATTERY).
- ◆ Remove the electronic unit, see 7.1.9 (REMOVING THE ELECTRONIC UNIT).
- ◆ ★ Disconnect the rear indicator's electric connector (1).

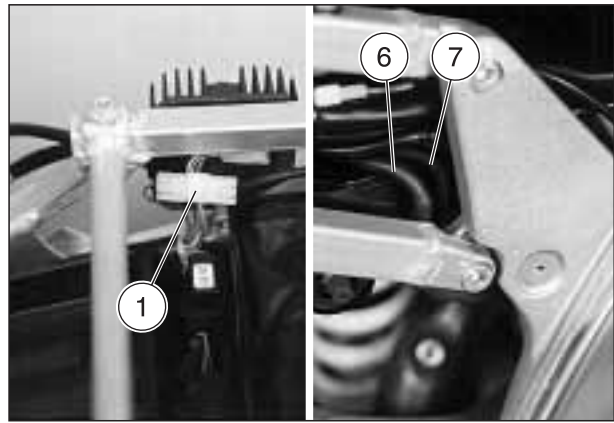

⚠ CAUTION

Upon reassembly, make sure that the electric connector (1) is correctly coupled.

- ◆ Unscrew and remove the three screws (2) securing the electronic unit casing (3) to the saddle support lower moulded cover and retrieve the three washers.
- ◆ Lift out the electronic unit casing (3); help the two electric connectors (4) (5) out through the special slot.

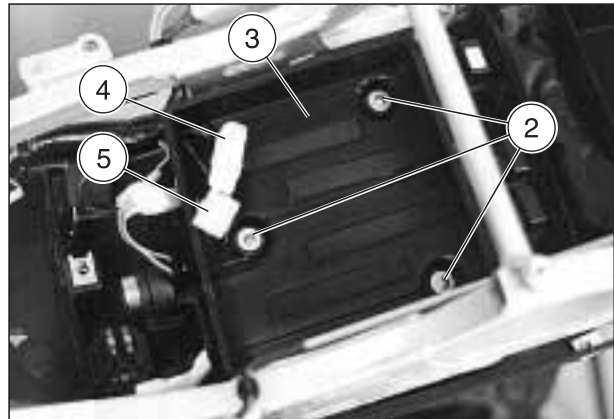

NOTE Should the three rubber parts in the lower part of the casing (3) prove damaged, replace them.

- ◆ Slide the fuel tank overflow drain pipe (6) and the filler cap drain pipe (7) off by pulling downwards.
- ◆ Release the support of the start relay (8) from its coupling.
- ◆ Release the fuse carrier (9) from its coupling.
- ◆ Release the fall sensor (10) from its coupling.
- ◆ Release the diode module (11), engine shutoff relay (12) and fuel pump relay (13) from their respective couplings.

Follow ►

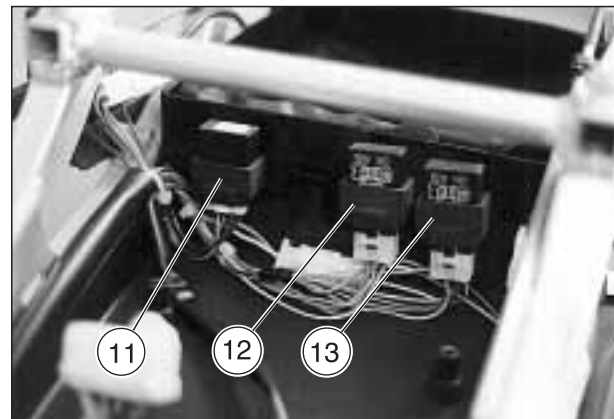
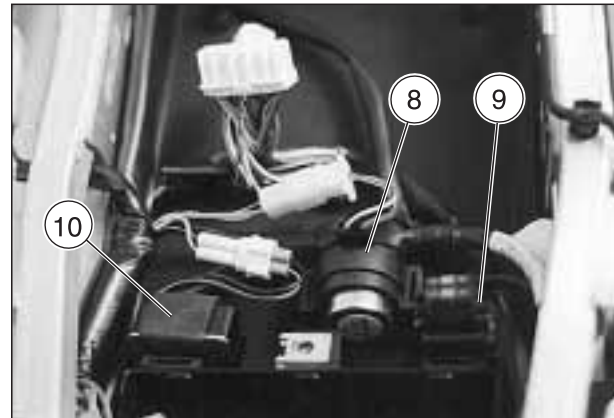

Follow ►

- ◆ Open the clamp (14) securing the wiring on the left.

⚠ CAUTION

When reassembling, make sure the electric components and relevant wiring are refitted correctly.

- ◆ Unscrew and remove the two front fastening screws (15).

Screws (15) driving torque: 4 Nm (0.4 kgm).

- ◆ ★ Loosen and remove the rear fastening nut (16).

Nut (16) driving torque: 4 Nm (0.4 kgm).

- ◆ ★ Pull the screw (17) out from underneath.
- ◆ ★ Unscrew and remove the lower fastening screw (18) and retrieve the bush (19) for securing luggage.

Screw (18) driving torque: 5 Nm (0.5 kgm).

- ◆ Lower the rear part and lift the front of the saddle support lower moulded cover (20).
- ◆ Remove the saddle support lower moulded cover (20), complete with direction indicators and number plate holder, sliding it off the back.

NOTE Where necessary, remove the number plate holder, see 7.1.42 (REMOVING THE NUMBER PLATE HOLDER) and the direction indicators, see 7.1.40 (REMOVING THE REAR DIRECTION INDICATORS).

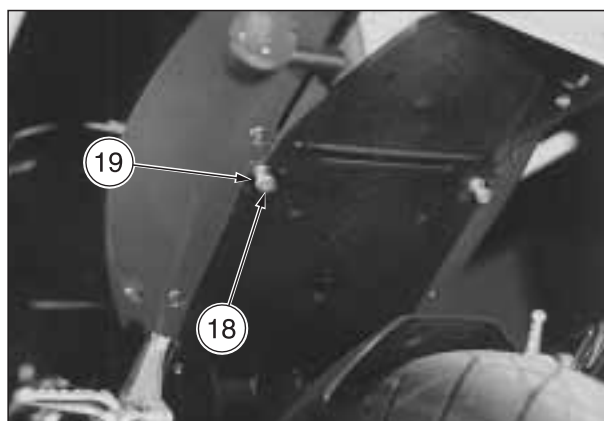
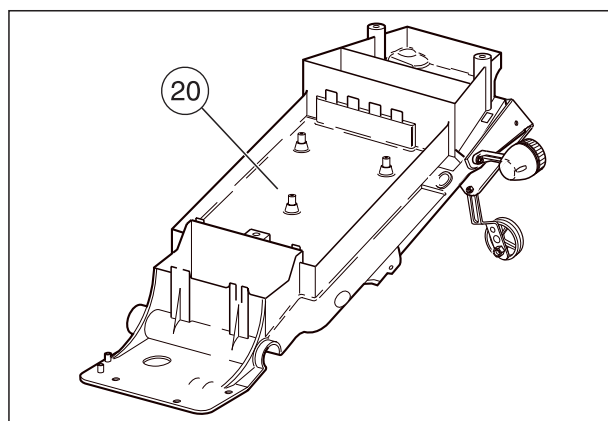
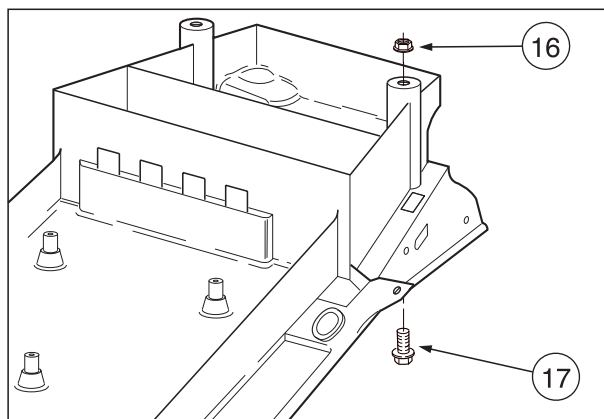

7.1.42 REMOVING THE NUMBER PLATE HOLDER

Carefully read 0.5.1 (PRECAUTIONS AND GENERAL INFORMATIONS).

- ◆ Remove the rear direction indicators (1), see 7.1.40 (REMOVING THE REAR DIRECTION INDICATORS).
- ◆ Retrieve the number plate holder (2) assembly with the rear reflector.

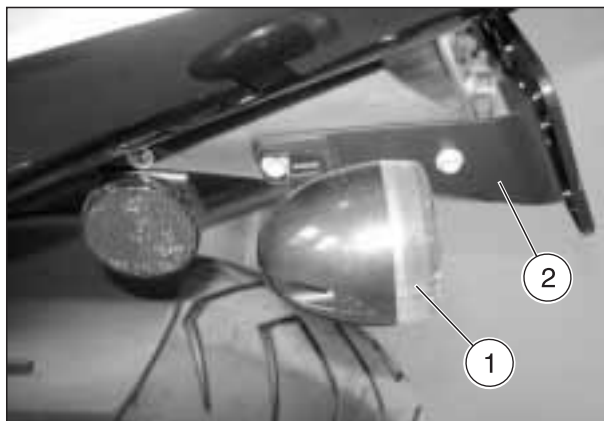

7.1.43 REMOVING THE REAR MUDGUARD

Carefully read 0.5.1 (PRECAUTIONS AND GENERAL INFORMATIONS).

- ◆ Position the vehicle on the stand.

⚠ CAUTION

Wait until the engine and the exhaust silencer have completely cooled down.

- ◆ ★ Unscrew and remove the two screws (3).

Screws (3) driving torque: 5 Nm (0.5 kgm).

- ◆ Remove the rear mudguard (4).

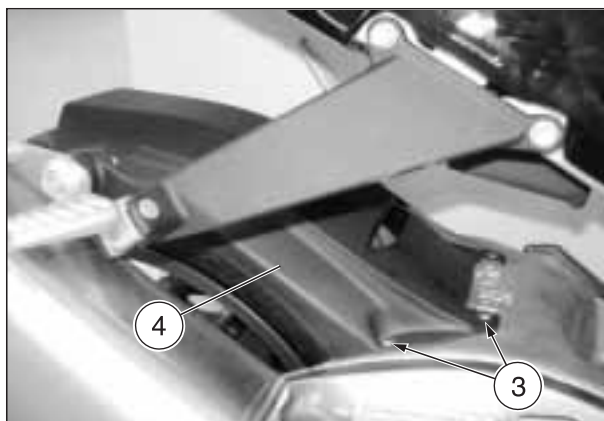

7.1.44 REMOVING THE PASSENGER FOOTREST SUPPORTS

Carefully read 0.5.1 (PRECAUTIONS AND GENERAL INFORMATIONS).

- ◆ Position the vehicle on the stand.
- ◆ Only for right-hand side passenger footrest support; remove the exhaust silencer, see 7.1.49 (REMOVING THE EXHAUST SILENCER).
- ◆ Unscrew and remove the two screws (5).

Screws (5) driving torque: 25 Nm (2.5 kgm).

- ◆ Remove the footrest support (6) complete with footrest.

To disassemble the components of the passenger footrest support, proceed as follows:

- ◆ Remove the footrest (7), see 7.1.47 (REMOVING THE RIDER'S FOOTREST).

NOTE Where necessary, repeat the procedure to remove the other passenger footrest support.

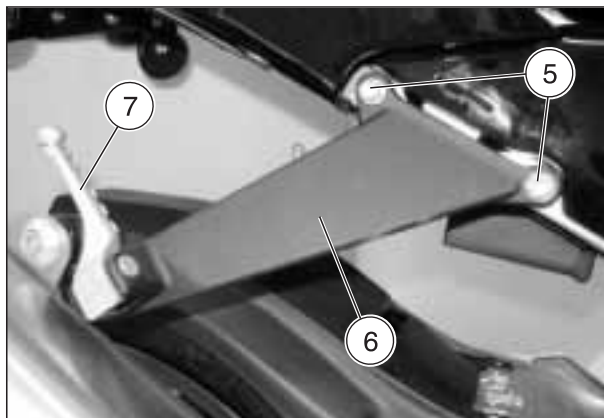

7.1.45 REMOVING THE PASSENGER FOOTREST

Carefully read 0.5.1 (PRECAUTIONS AND GENERAL INFORMATIONS).

- ◆ Position the vehicle on the stand.

⚠ WARNING

Wait until the engine and the exhaust silencer have completely cooled down.

- ◆ Remove the stop ring (1).
- ◆ Slide out the pin (2).

⚠ CAUTION

Take care not to loose the ball (5) ejected by the spring (6) in the process.

- ◆ Remove the footrest (3) and retrieve the two shims (4), ball (5) and spring (6).

NOTE Where necessary, repeat the procedure to remove the other footrest.

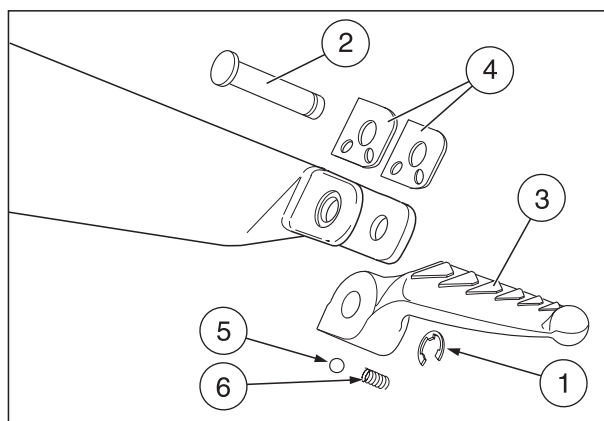

7.1.46 REMOVING THE RIDER'S FOOTREST SUPPORTS

Carefully read 0.5.1 (PRECAUTIONS AND GENERAL INFORMATIONS).

- ◆ Position the vehicle on the stand.

⚠ WARNING

Wait until the engine and the exhaust silencer have completely cooled down.

- ◆ Unscrew and remove the screw (7) supporting the lower fairing.

Screw (7) driving torque: 5 Nm (0.5 kgm).

- ◆ Unscrew and remove the two screws (8).

Screws (8) driving torque: 25 Nm (2.5 kgm).

- ◆ Remove the whole rider's footrest support (9).

NOTE Where necessary, repeat the procedure to remove the other rider's footrest support.

To disassemble the components of the rider footrest support, proceed as follows:

- ◆ Unscrew and remove the two screws (10) and retrieve the protection element (11).

Screws (10) driving torque: 6 Nm (0.6 kgm).

- ◆ Unscrew and remove the screw (12) and retrieve the bracket (13).

Screw (12) driving torque: 12 Nm (1.2 kgm).

- ◆ Remove the rider footrest (9), see 7.1.47 (REMOVING THE RIDER'S FOOTREST).

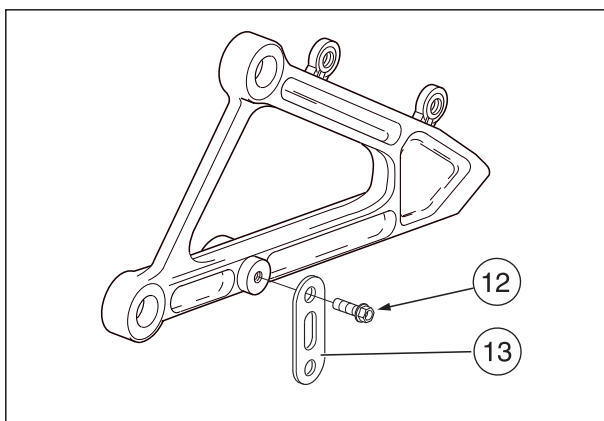
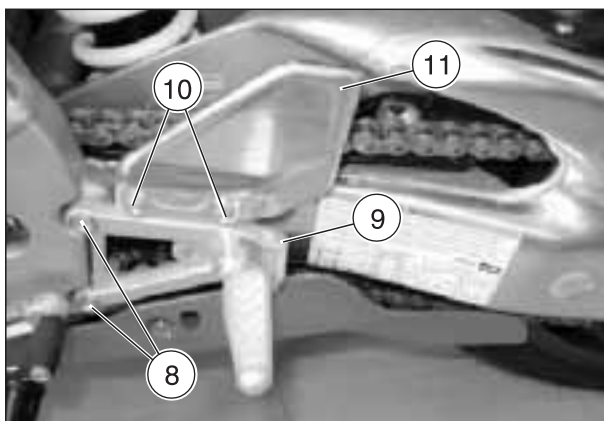
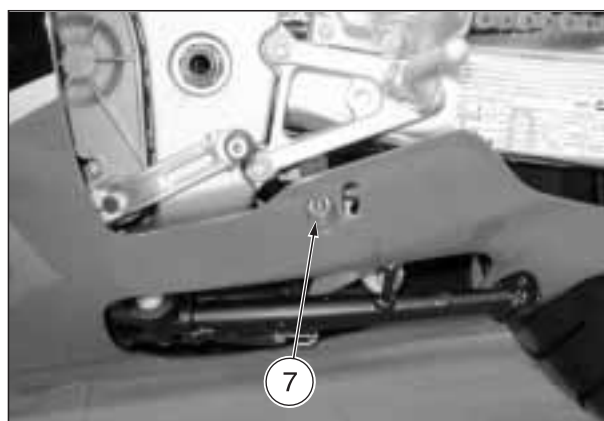

7.1.47 REMOVING THE RIDER'S FOOTREST

Carefully read 0.5.1 (PRECAUTIONS AND GENERAL INFORMATIONS).

- ◆ Position the vehicle on the stand.

▲ WARNING

Wait until the engine and the exhaust silencer have completely cooled down.

- ◆ Remove the stop ring (1).
- ◆ Slide out the pin (2).
- ◆ Retrieve the footrest (3) and the spring (4).

NOTE Where necessary, repeat the procedure to remove the other rider's footrest.

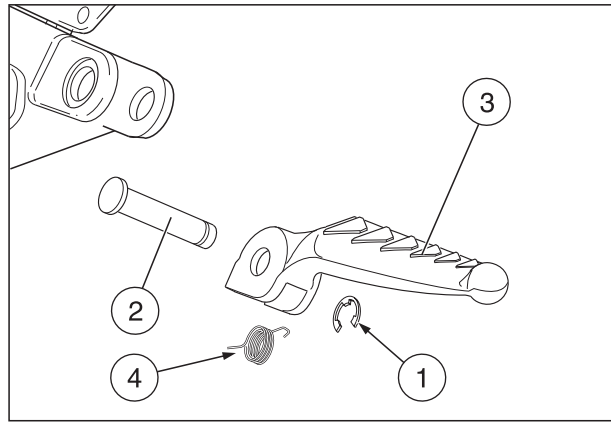

7.1.48 REMOVING THE REAR BRAKE LEVER

Carefully read 0.5.1 (PRECAUTIONS AND GENERAL INFORMATIONS).

NOTE The following procedure does not necessarily have to be performed with the lower fairing removed, though it is advisable to remove it in order to gain more room for manoeuvre, see 7.1.34 (REMOVING THE LOWER FAIRING).

- ◆ Move the retaining ring (5).
- ◆ Turn the fork pin (6) downwards.
- ◆ Slide out the fork pin (6).
- ◆ Disengage the spring (7) from the lever (8).

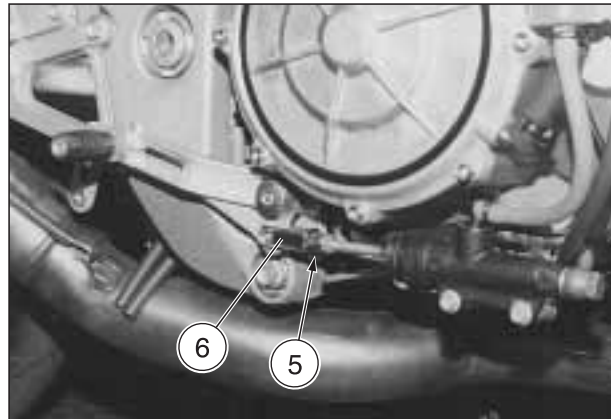

Pin (9) driving torque: 15 Nm (1.5 kgm).

- ◆ Unscrew and remove the pin (9) and retrieve:
 - the O-ring (10);
 - the lever (8);
 - the washer (11);
 - the O-ring (12).

NOTE When reassembling, apply LOCTITE® 243 on the thread of the pin (9).

Remove the mount (16) of the rear brake lever:

- ◆ Remove the rear brake light switch (13).

Screw (14) driving torque: 25 Nm (2.5 kgm).

- ◆ Unscrew and remove the screw (14).

Screw (15) driving torque: 12 Nm (1.2 kgm).

- ◆ Unscrew and remove the screw (15).
- ◆ Remove the mount (16) of the rear brake lever.

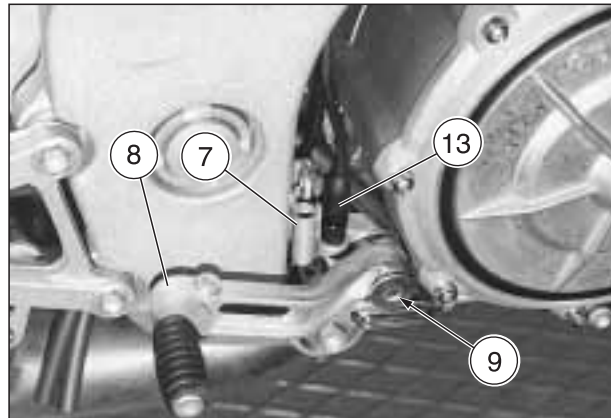

Upon reassembly:

NOTE Do not invert the assembly position of the two screws (14) (15). The screw (15) is the shortest.

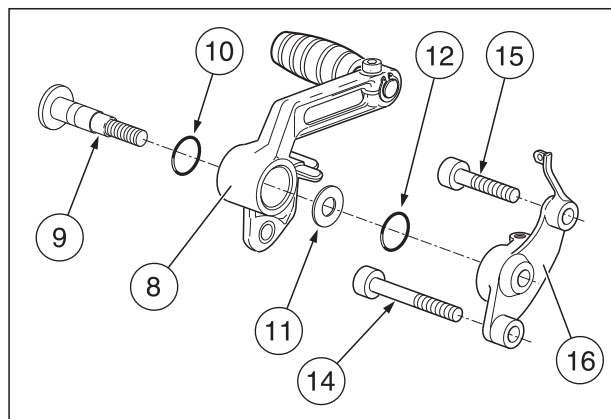

7.1.49 REMOVING THE EXHAUST SILENCER

Carefully read 0.5.1 (PRECAUTIONS AND GENERAL INFORMATIONS).

- ◆ Position the vehicle on the stand.

⚠ WARNING

Wait until the engine and the exhaust silencer have completely cooled down.

- ◆ Release the two springs (1) from their respective hooks on the exhaust silencer (2).

⚠ CAUTION

Check the two springs (1) and replace them should they be damaged.

- ◆ Loosen and remove the self-locking nut (3) and retrieve the washer (4).

Nut (3) driving torque: 25 Nm (2.5 kgm).

- ◆ Unscrew and remove the screw (5) and retrieve the bush (6) and washer (7).
- ◆ If the rubber elements (8) are damaged, change them and retrieve the inner spacer (9).
- ◆ Rotate the exhaust silencer (2) slightly both ways in order to dislodge any deposits preventing it from being removed.
- ◆ Slide out the exhaust silencer (2).

⚠ CAUTION

Plug the exhaust pipe openings so as to prevent any foreign bodies entering.

⚠ CAUTION

If necessary, replace the exhaust silencer with a new one of the same type.

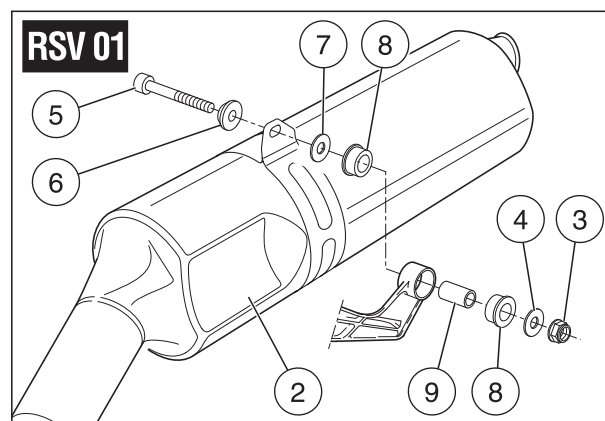
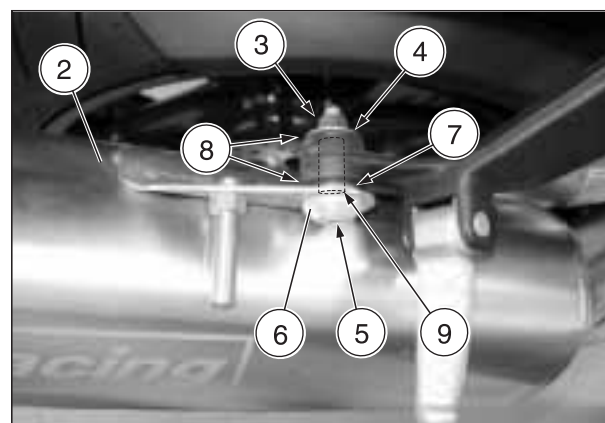
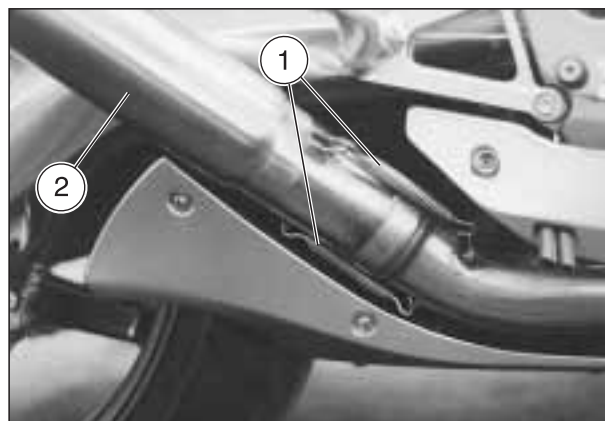

7.1.50 REMOVING THE SIDE STAND

Carefully read 0.5.1 (PRECAUTIONS AND GENERAL INFORMATIONS).

Only when the vehicle must be used on racetracks, it is advisable to remove the stand (1) complete with:

- springs (2);
- support (3);
- safety switch (4).

NOTE The removal of the safety switch (4) disconnects the electric circuit; to restore it, connect the wiring (6) (aprilia part# 8124943), to the connector (5).

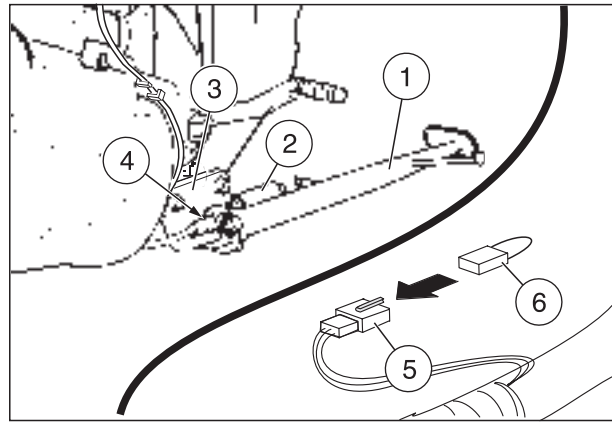

CAUTION

Neither lean the vehicle against walls, nor lay it on the ground.

To park the vehicle without stand (the removal of the stand is allowed only for the use of the vehicle on racetracks), always and exclusively use the rear support stand.

WARNING

It is forbidden to disconnect or remove the safety switch (4) separately from the stand.

The disconnection or removal of the safety switch (4) alone makes it possible to start the vehicle and leave with the stand down, which may result in a fall and in serious injuries to the rider and other people and damage to the vehicle itself.

For the removal, proceed as follows:

- ◆ Remove the left side cover, see 7.1.3 (REMOVING THE SIDE COVERS).
- ◆ Remove the lower fairing, see 7.1.34 (REMOVING THE LOWER FAIRING).
- ◆ Lift the fuel tank, see 2.8 (LIFTING THE FUEL TANK).

NOTE Prepare a clamp (7) to be used for the reassembly.

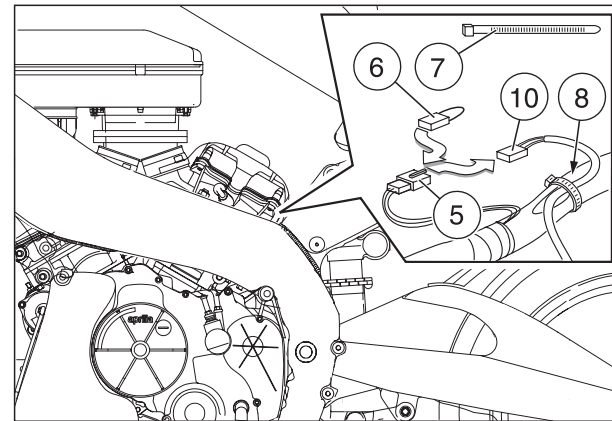

CAUTION

Do not force cables, pipes, connectors and wires.

- ◆ Cut the clamp (8) and release the cable (9).
- ◆ Disconnect the electric connector (10) from the connector (5).
- ◆ Connect [to replace the electric connector (10)] the wiring (6) (aprilia part # 8124943).
- ◆ Withdraw the cable (9) completely.
- ◆ Put back the fuel tank, see 2.8 (LIFTING THE FUEL TANK).
- ◆ Put back the left side cover, see 7.1.3 (REMOVING THE SIDE COVERS).

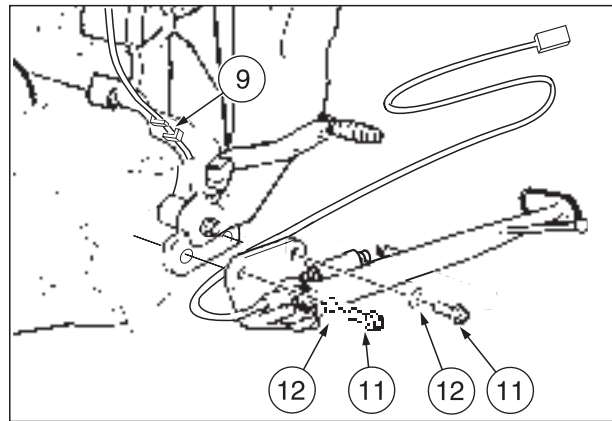

NOTE Support the stand, in order to prevent it from accidentally falling down.

Screws (11) driving torque: 40 Nm (4 kgm).

- ◆ Unscrew and remove the screws (11) and take the washers (12).
- ◆ Remove the stand (1) complete with:
 - springs (2);
 - support (3);
 - safety switch (4).

NOTE Store the following components together: complete stand, screws (11) and washers (12), in order to be able to install them correctly when the vehicle must be used on roads.

- ◆ Put back the lower fairing (and the two side fairings), see 7.1.34 (REMOVING THE LOWER FAIRING).

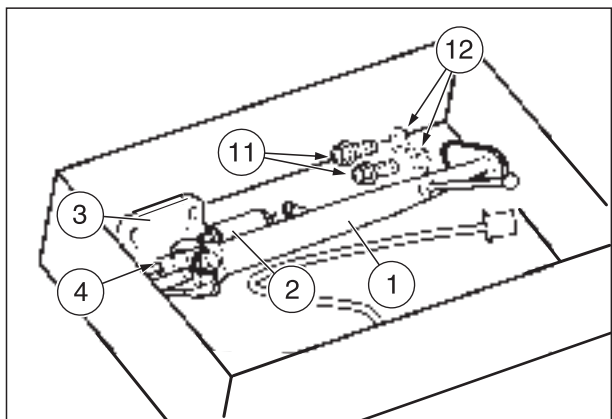

7.1.51 REMOVING THE ENGINE OIL TANK

Carefully read 0.5.1 (PRECAUTIONS AND GENERAL INFORMATIONS) and 1.2.2 (ENGINE OIL).

- ◆ Drain the engine oil tank completely, see 2.14 (CHANGING THE ENGINE OIL AND THE OIL FILTER).

NOTE Have the appropriate special tool **OPT** to hand:
– aprilia part# 0277295 (hose clamp installation pliers).

⚠ CAUTION

Upon installation, replace the hose clamp that has been removed with a new one having the same dimensions, see 0.4.2 (SPARE PARTS CATALOGUES).

Do not attempt to reinstall the removed hose clamp, since it is unusable.

Do not replace the removed hose clamp with a screw clamp or with other types of clamp.

- ◆ Release the hose clamp (2).
- ◆ Release the hose clamp (3).
- ◆ Pull off the couplings (4) (5).
- ◆ Unscrew and remove the upper fastening screw (6).

Screw (6) driving torque: 10 Nm (1.0 kgm).

NOTE If the rubber element proves damaged, replace it.

- ◆ Loosen and remove the two nuts (7) (8).

Nuts (7) (8) driving torque: 10 Nm (1.0 kgm).

NOTE If the two silent-blocks prove damaged, replace them.

- ◆ Remove the whole tank (9).
- ◆ Unscrew and remove the engine oil filter (10) positioned on the tank and clean it with a jet of compressed air.
- ◆ Check the engine oil filter gasket on the tank (9), screw it on and tighten up.

Engine oil filter on tank (9) driving torque: 30 Nm (3.0 kgm).

To remove the engine oil level pipe (12), proceed as follows:

Screws (11) driving torque: 20 Nm (2.0 kgm).

- ◆ Unscrew and remove the two screws (11).
- ◆ Remove the oil level pipe (12) and retrieve the gaskets.

NOTE If the oil level pipe and gaskets prove damaged, replace them.

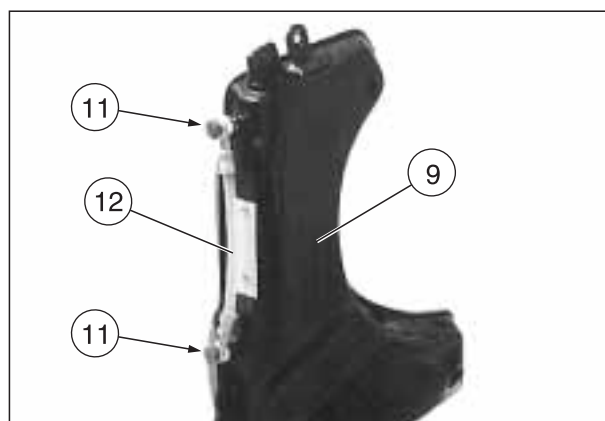
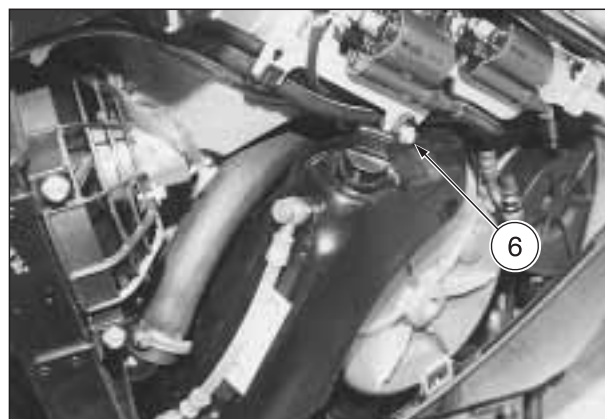
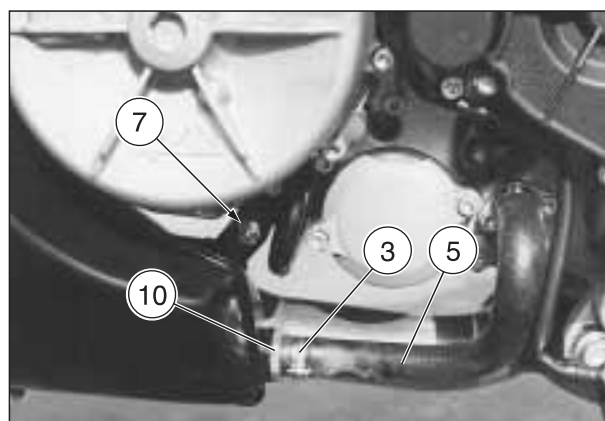
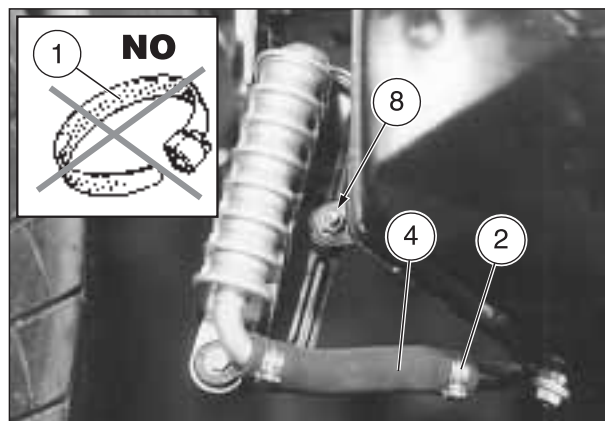

7.1.52 REMOVING THE ENGINE OIL RADIATOR

Carefully read 0.5.1 (PRECAUTIONS AND GENERAL INFORMATIONS) and 1.2.2 (ENGINE OIL).

- ◆ Drain the engine oil tank completely, see 2.14 (CHANGING THE ENGINE OIL AND THE OIL FILTER).

NOTE Have the appropriate special tool **OPT** to hand:
 – **aprilia** part# 0277295 (hose clamp installation pliers).

CAUTION

Upon installation, replace the hose clamp that has been removed with a new one having the same dimensions, see 0.4.2 (SPARE PARTS CATALOGUES).

Do not attempt to reinstall the removed hose clamp, since it is unusable.

Do not replace the removed hose clamp with a screw clamp or with other types of clamp.

- ◆ Release the hose clamp (2).
- ◆ Release the hose clamp (3).
- ◆ Pull off the couplings (4) (5).
- ◆ Unscrew and remove the three fastening screws (6) (7) (8).

Screws (6) (7) (8) driving torque: 12 Nm (1.2 kgm).

NOTE If the rubber elements are damaged, change them.

- ◆ Remove the radiator (9).

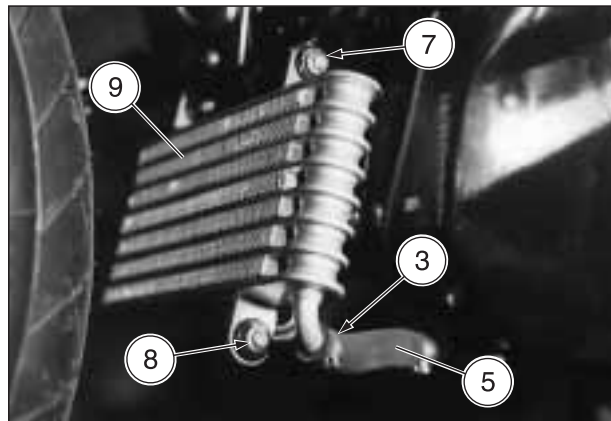
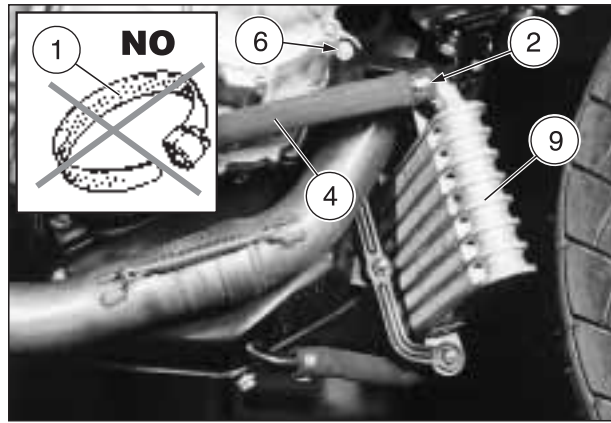

7.1.53 REMOVING THE DRIVE PINION

- ◆ Remove the guide plate, see 2.36.5 (INSPECTING THE DRIVING CHAIN GUIDE PLATE).

NOTE In order to stop the pinion (13) from turning and enable the screw (10) to be unscrewed, put the vehicle in first gear.

- ◆ Unscrew and remove the screw (10) and retrieve the two washers (11) (12).

Screw (10) driving torque: 50 Nm (5.0 kgm).

NOTE When reassembling, apply LOCTITE® 243 on the thread of the screw (10).

NOTE In order to make it easier to slide off the drive pinion (13), slacken the chain slightly, see 2.36.3 (ADJUSTING THE DRIVING CHAIN).

- ◆ Slide the drive pinion (13), complete with chain, off the shaft.
- ◆ Remove the drive pinion (13).

NOTE Upon reassembly, apply LOCTITE® Anti-Seize to the inner toothing of the drive pinion (13) and insert it on the gearbox output shaft with the collar facing inwards.

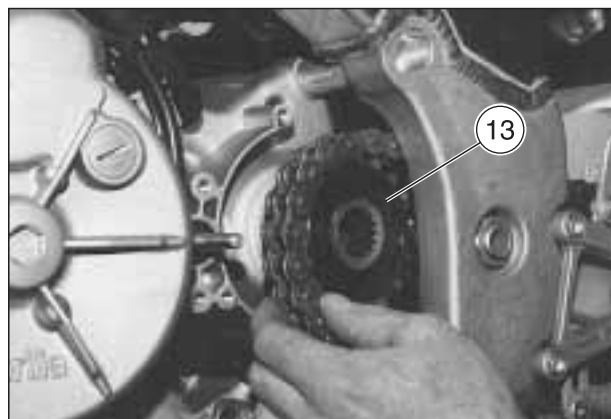
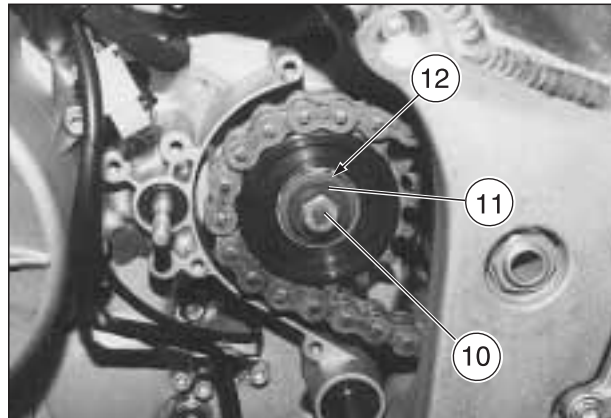

7.1.54 REMOVING THE DRIVING CHAIN SHOE

Carefully read 0.5.1 (PRECAUTIONS AND GENERAL INFORMATIONS).

- ◆ Remove the drive pinion, see 7.1.53 (REMOVING THE DRIVE PINION).
- ◆ Unscrew and remove the screw (1).
- ◆ Unscrew and remove the screw (2).
- ◆ Remove the shoe (3) by pulling it off towards the front.

NOTE When reassembling, make sure the slot in the shoe (3) is correctly positioned on its seat (4) built into the fork.

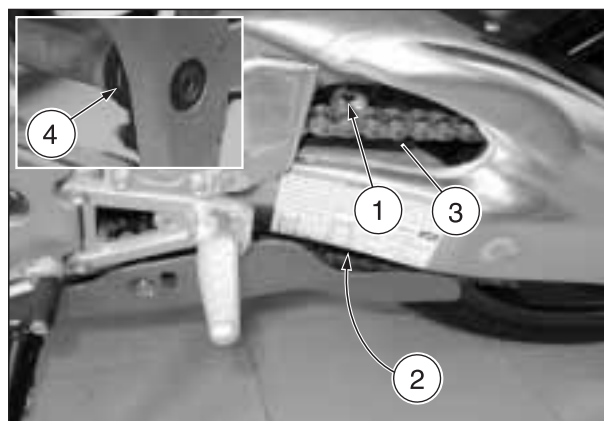

7.1.55 DRAINING THE CLUTCH CONTROL SYSTEM

Carefully read 0.5.1 (PRECAUTIONS AND GENERAL INFORMATIONS) and 1.2.6 (CLUTCH FLUID).

⚠ CAUTION

Use latex gloves.

Handle clutch fluid with care; it may chemically alter painted surfaces and the parts in plastic, rubber, etc.

DO NOT DISPOSE OF THE FLUID IN THE ENVIRONMENT.

⚠ WARNING

Considering that the situation can be very dangerous for the rider and the vehicle, after the reassembly of the clutch control cylinder and/or after the normal operating conditions of the clutch system have been restored, it is absolutely necessary to bleed the hydraulic circuit, see 2.21 (BLEEDING THE CLUTCH SYSTEMS).

- ◆ Position the vehicle on the side stand.
- ◆ Remove the plastic protection cap.
- ◆ Insert a small rubber pipe on the bleeder (5).
- ◆ Introduce the free end of the small rubber pipe into a clean container for the collection of the fluid.
- ◆ Loosen the bleeder (5) one turn.
- ◆ Slowly pull the clutch control lever thoroughly. Repeat the operation until all the clutch fluid has flown into the container.
- ◆ Tighten the bleeder (5).

Bleeder (5) driving torque: 15 Nm (1.5 kgm).

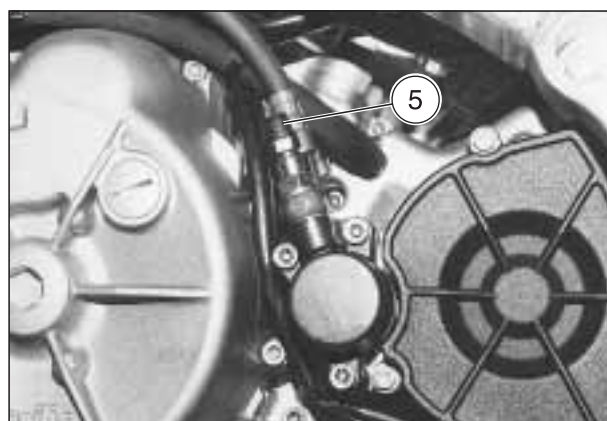

⚠ CAUTION

Clean the small rubber pipe (on its whole length) and the bleeder valve, removing any residue of clutch fluid.

- ◆ Remove the small rubber pipe and clean it.
- ◆ Refit the rubber protection cap.
- ◆ Plug the container.

7.1.56 REMOVING THE SADDLE SUPPORT

Carefully read 0.5.1 (PRECAUTIONS AND GENERAL INFORMATIONS).

- ◆ Position the vehicle on the appropriate rear support stand, see 1.8.2 (POSITIONING THE VEHICLE ON THE REAR SUPPORT STAND **OPT**).
- ◆ Remove the saddle support lower moulded cover, see 7.1.41 (REMOVING THE SADDLE SUPPORT LOWER MOULDED COVER).
- ◆ Remove the number plate holder, see 7.1.42 (REMOVING THE NUMBER PLATE HOLDER).
- ◆ Remove the exhaust silencer, see 7.1.49 (REMOVING THE EXHAUST SILENCER).
- ◆ Disconnect the two electric connectors (1) (2).

⚠ CAUTION

When reassembling, make sure the electric connectors (1) (2) are plugged in properly.

- ◆ ★ Unscrew and remove the two screws (3).

Screws (3) driving torque: 50 Nm (5.0 kgm).

- ◆ Remove the saddle support (4), sliding it off the back.

To remove the components attached to the saddle support (4):

- ◆ Unscrew and remove the two screws (5) and remove the voltage regulator (6).

Screws (5) driving torque: 12 Nm (1.2 kgm).

- ◆ Remove the passenger seat lock, see 7.1.39 (REMOVING THE PASSENGER SEAT LOCK).
- ◆ Remove the passenger footrest supports, see 7.1.44 (REMOVING THE PASSENGER FOOTREST SUPPORTS).
- ◆ Remove the fuel tank support rod.

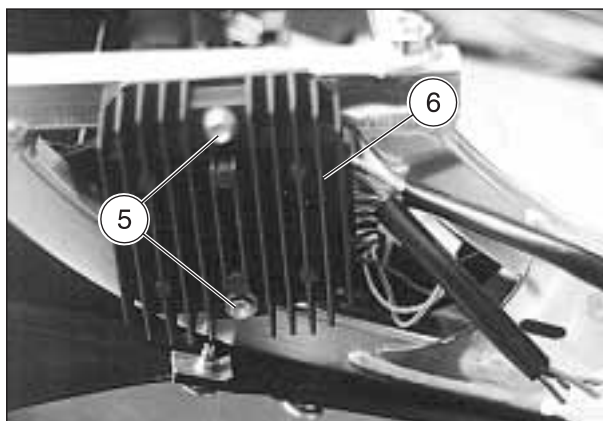
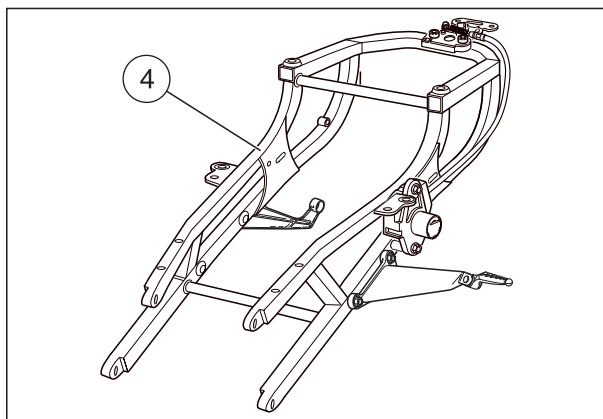
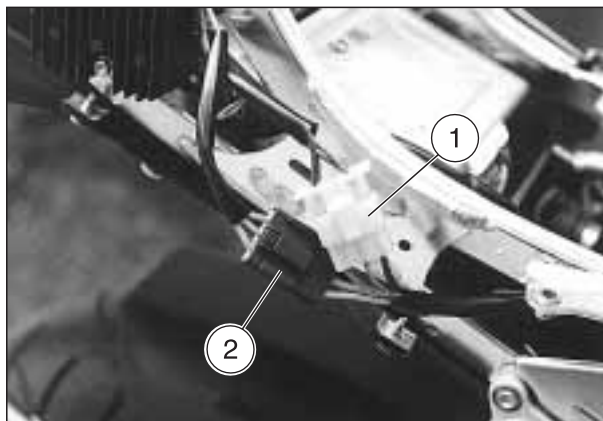

7.1.57 REMOVING THE FRAME

⚠ CAUTION

The frame (1) must be removed by an authorized centre or by an **aprilia** Official Dealer only.

Carefully read 0.5.1 (PRECAUTIONS AND GENERAL INFORMATIONS).

⚠ CAUTION

The removal of the frame (1) is a particularly complex operation. Therefore, inspect the vehicle carefully before proceeding.

This chapter describes the relevant procedures progressively and in sequential order.

Any reference to operations from other chapters must be interpreted logically in order to avoid components being removed unnecessarily.

Only perform those operations necessary to remove the component in question.

- ◆ Remove the engine, see 3.3 (REMOVING THE WHOLE ENGINE FROM THE FRAME).
- ◆ Position the vehicle on the special centre stand, see 1.8.4 (POSITIONING THE VEHICLE ON THE CENTRE SUPPORT STAND **OPT**).
- ◆ Remove the forecarriage complete with front wheel, see 7.7.1 (REMOVING THE FORK TOGETHER WITH THE FRONT WHEEL).
- ◆ Remove the dashboard mount, see 7.1.26 (REMOVING THE DASHBOARD/FRONT FAIRING MOUNT).
- ◆ Remove the side fairing upper panels, see 7.1.29 (REMOVING THE SIDE FAIRING UPPER PANELS).
- ◆ Remove the air conveyor cases, see 7.1.33 (REMOVING THE AIR CONVEYOR).
- ◆ Remove the saddle support complete with footrest, see 7.1.56 (REMOVING THE SADDLE SUPPORT).
- ◆ Remove the rear axle complete with rear wheel, see 7.9.1 (REMOVING THE REAR FORK).
- ◆ Remove the rear shock absorber, see 7.10.1 (REMOVING THE SHOCK ABSORBER (models up to 2001)).
- ◆ ★ Disconnect the terminals (1) (2) and (3) (4) from the H.V. coils (5) (6).

⚠ CAUTION

When reassembling, make sure the electric terminals (1) (2) and (3) (4) are connected properly.

- ◆ ★ Unscrew and remove the two screws (7).

Screws (7) driving torque: 12 Nm (1.2 kgm).

- ◆ ★ Retrieve the plate (8) holding up the fairing.

⚠ CAUTION

When removing the coil mount (9), be extremely careful not to damage the H.V. coils (5) (6).

- ◆ Remove the filler neck, see 5.7 (REMOVING THE FILLER NECK).
- ◆ ★ Remove the coil mount (9) complete with H.V. coils (5) (6).
- ◆ Remove the rider's footrest supports, see 7.1.46 (REMOVING THE RIDER'S FOOTREST SUPPORTS).

Follow ►

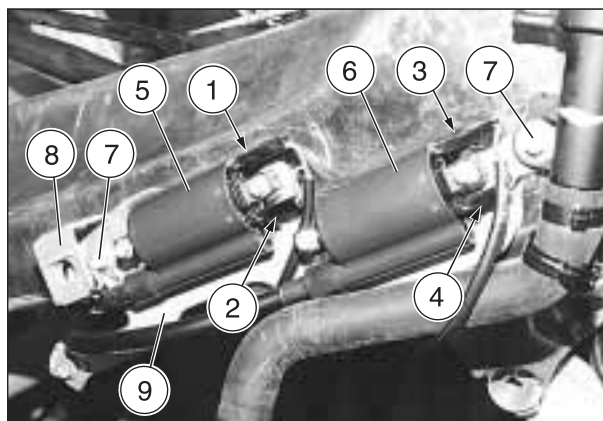
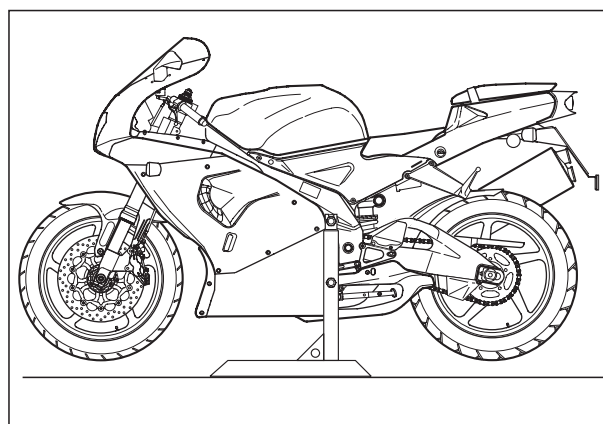
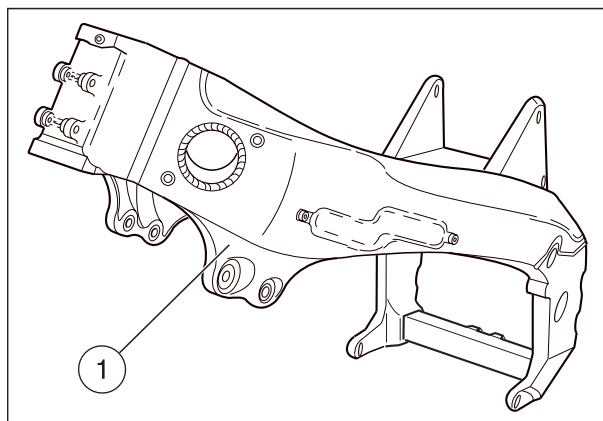

Follow ►

⚠ CAUTION

Release all the cables from the fastening clamps positioned along them.
Prepare the same number of clamps, which will be required for reassembly.

- ◆ Remove the side stand, see 7.1.50 (REMOVING THE SIDE STAND).
- ◆ ★ Unscrew and remove the screw (10) and remove the side panel support plate (11).
- ◆ Place the frame (1) in an appropriate sling and attach the bands (12) to a hoist (13) for support.

⚠ CAUTION

The bands (12) and the hoist (13) must be suitable for bearing the weight of the frame (1).

The frame weighs: 9.9 kg.

- ◆ Lift the frame (1) just enough to remove the special centre support stand **OPT**.
- ◆ Remove the centre stand (14), see 1.8.4 (POSITIONING THE VEHICLE ON THE CENTRE SUPPORT STAND **OPT**).

Once the frame has been completely reinstalled, proceed as follows:

- ◆ Make sure that all the components are correctly fastened.
- ◆ Make sure that cables and electric wiring are correctly positioned and fastened.
- ◆ Make sure the electric connectors are plugged in properly.
- ◆ Make sure that turning the handlebars does not result in any of the cables or pipes being pulled too tight.

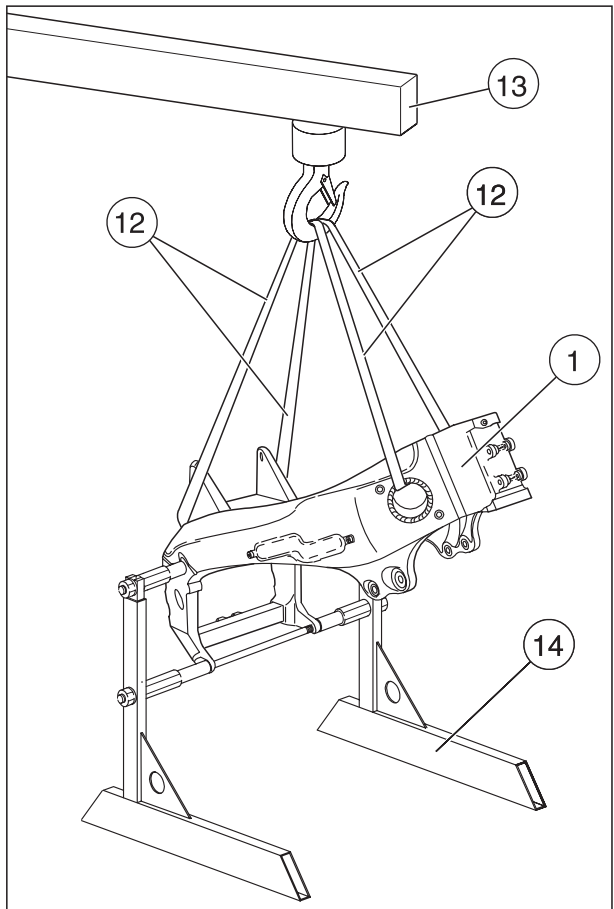
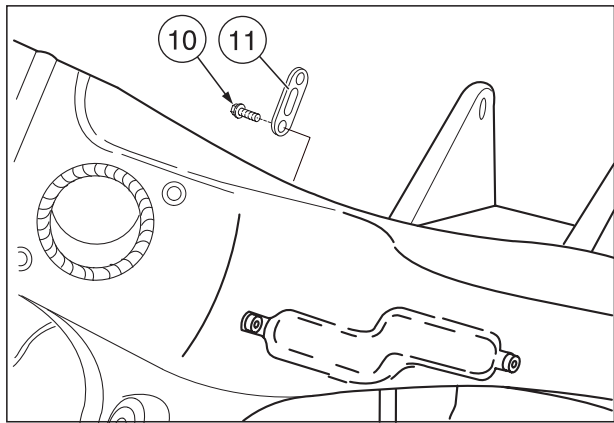

7.2 FRONT WHEEL

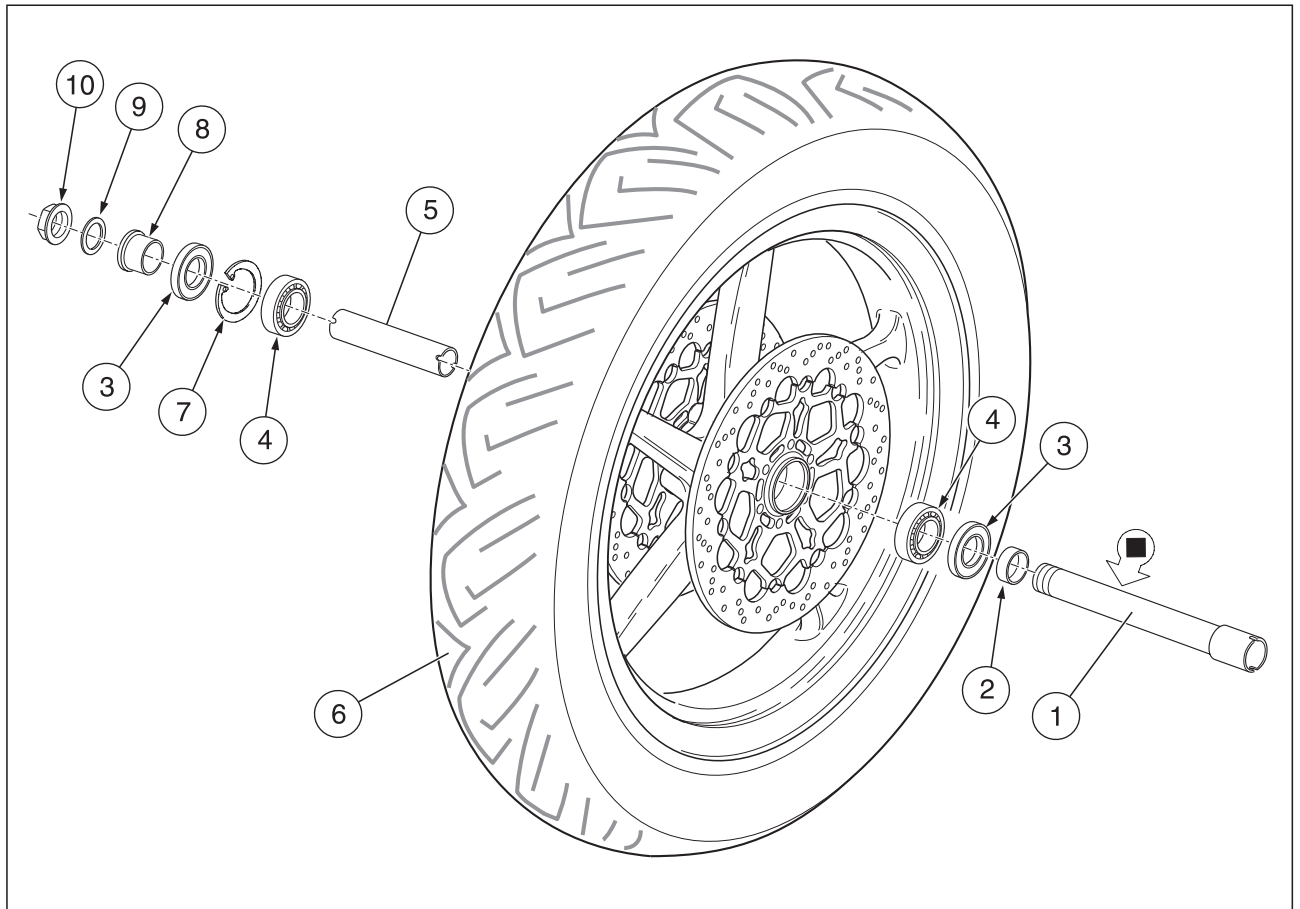

Key

- 1) Wheel pin
- 2) Left spacer (up to frame # ZDMEE009YS000292)
- 3) Seal
- 4) Bearing
- 5) Inner spacer
- 6) Complete wheel
- 7) Snap ring
- 8) Right spacer
- 9) Washer
- 10) Nut

■ = GREASE, see 1.6 (LUBRICANT CHART).

7.2.1 REMOVING THE FRONT WHEEL

Carefully read 0.5.1 (PRECAUTIONS AND GENERAL INFORMATIONS) and 2.33 (FRONT WHEEL).

CAUTION

While disassembling and reassembling the wheel, be careful not to damage the brake pipes, the discs and the pads.

WARNING

Riding with damaged rims may be dangerous for the rider, other persons and the vehicle. Check the conditions of the wheel rim and change it if it is damaged.

DISASSEMBLY

- ◆ Remove the front brake calipers, see 7.5.6 (REMOVING THE FRONT BRAKE CALIPERS)
- ◆ Put a support (1) under the tyre, in such a way as to keep the wheel in its position after loosening it.

CAUTION

Make sure that the vehicle is stable.

- ◆ Have someone keep the handlebar steady in running position, so that the steering is locked.

Wheel nut (2) driving torque: 80 Nm (8 kgm).

- ◆ Loosen and remove the wheel nut (2), taking the washer (3).

Wheel pin clamp screw driving torque: 22 Nm (2.2 kgm).

- ◆ Partially unscrew the two wheel pin clamp screws (4) (right side).
- ◆ Partially unscrew the two wheel pin clamp screws (5) (left side).

NOTE Check the position of the spacer ring (6) (right side), in order to be able to reinstall it correctly.

NOTE To facilitate the extraction of the wheel pin, slightly raise the wheel.

- ◆ Push the wheel pin (7), by carefully acting on the threaded end and using a rubber hammer if necessary.
- ◆ Support the front wheel and manually withdraw the wheel pin (7).
- ◆ Remove the wheel by withdrawing it from the front.

CAUTION

The spacer ring (6) remains in its seat on the wheel; if it comes off, reposition it correctly.

- ◆ up to frame # ZD4MEE009YS000292. Take the left spacer (8).
- ◆ Where necessary, disassemble the wheel completely, see 7.2.9 (DISASSEMBLING THE FRONT WHEEL BEARINGS).

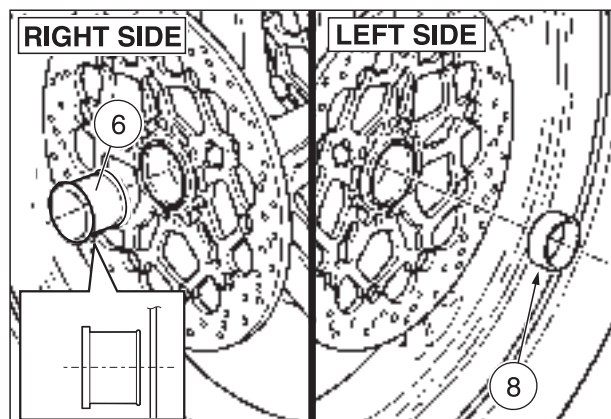
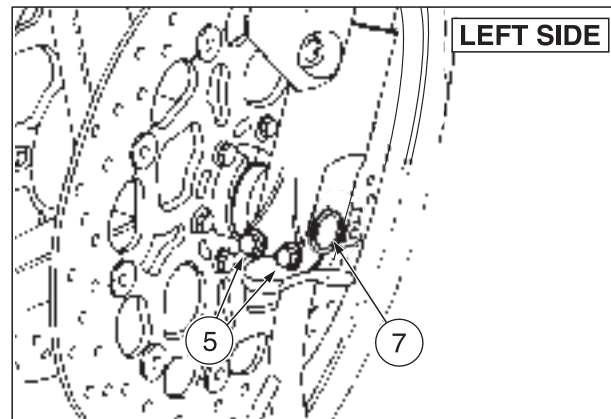
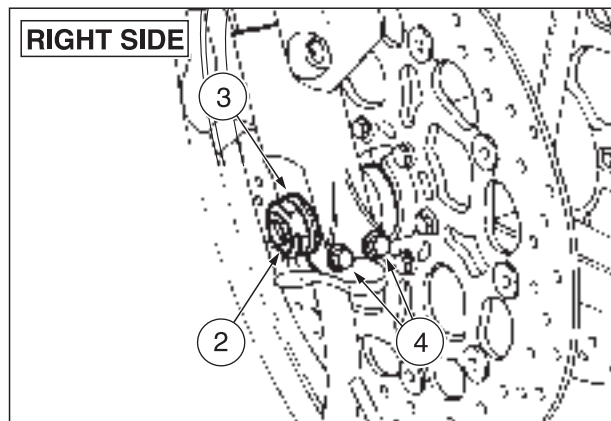
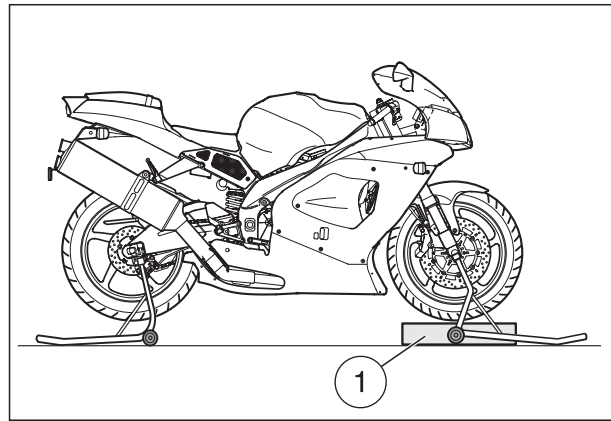

7.2.2 CHECKING THE FRONT WHEEL COMPONENTS

CAUTION

Make sure that all the components are intact, particularly the following.

7.2.3 FRONT WHEEL BEARINGS

Carry out the check with the bearings mounted on the wheel.

CHECKING THE ROTATION

- ◆ Manually rotate the inner ring of each single bearing. The rotation must be regular, smooth and noiseless.

If one or both bearings is/are not in compliance with the check parameters:

- ◆ Change both wheel bearings, see 7.2.10 (ASSEMBLING THE FRONT WHEEL BEARINGS).

WARNING

Always change both bearings.
Always replace the bearings with bearings of the same type.

CHECKING THE END AND RADIAL PLAY

- ◆ Check the radial play and the end play.

End play: a minimum end play is allowed.

Radial play: none.

If one or both bearings is/are not in compliance with the check parameters:

- ◆ Change both wheel bearings, see 7.2.10 (ASSEMBLING THE FRONT WHEEL BEARINGS).

WARNING

Always change both bearings.
Always replace the bearings with bearings of the same type.



7.2.4 FRONT WHEEL GASKETS

- ◆ Make sure the seals are intact; should they prove damaged or feature signs of excessive wear, change them.

▲ WARNING

Always change both seals.

Always replace the gaskets with gaskets of the same type.

7.2.5 FRONT WHEEL PIN

- ◆ Check the eccentricity of the pin wheel (1) by means of a comparator. If the eccentricity exceeds the limit value, change the pin wheel (1).

Maximum eccentricity: 0.25 mm.

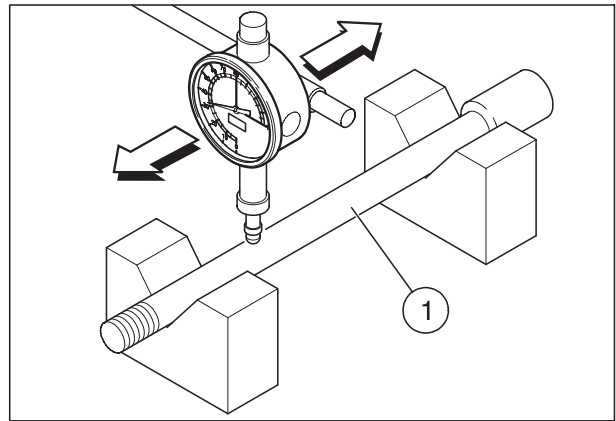

7.2.6 FRONT WHEEL RIM

- ◆ Using a comparator, make sure that the radial (A) and axial (B) eccentricity of the rim (2) do not exceed the limit value.

Excessive eccentricity is usually caused by worn or damaged bearings.

If, after changing the bearings, the value does not fall within the indicated limit, change the rim (2).

Maximum radial and axial eccentricity: 2 mm.

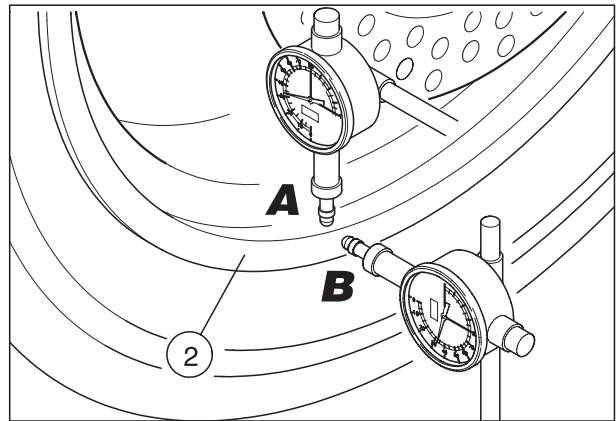

7.2.7 FRONT TYRE

- ◆ Check the state of the tyre, see 2.37 (TYRES) and 7.4 (TYRES).

7.2.8 FRONT BRAKE DISCS

- ◆ Check the front brake discs, see 7.5.3 (CHECKING THE FRONT BRAKE DISCS).

7.2.9 DISASSEMBLING THE FRONT WHEEL BEARINGS

Carefully read 0.5.1 (PRECAUTIONS AND GENERAL INFORMATIONS).

- ◆ Remove the front wheel, see 7.2.1 (REMOVING THE FRONT WHEEL).
- ◆ Use a cloth to clean both sides of the hub.

Work on the right side of the wheel:

- ◆ Remove the right spacer (1).
- ◆ Remove the seal (2).
- ◆ Remove the snap ring (3).

NOTE The elastic ring (3) is provided only on the right side of the wheel.

The ends of the spacer (4) are provided with slots (A) to allow the passage of the extractor teeth.

NOTE Have the appropriate special tool **OPT** to hand:
 – **aprilia** part# 8140180 (bearing extractors).

- ◆ Use a special extractor to extract the right bearing (5).
- ◆ Retrieve the inner spacer (4).

Work from the left-hand side of the wheel:

- ◆ **up to frame # ZD4MEE009YS000292.** Remove the spacer (B).
- ◆ Remove the seal (2).

NOTE Have the appropriate special tool **OPT** to hand:
 – **aprilia** part# 8140180 (bearing extractors).

- ◆ Use a special extractor to extract the left bearing (6).
- ◆ Thoroughly clean the inside of the hub.

NOTE Wash all the components with a clean detergent.

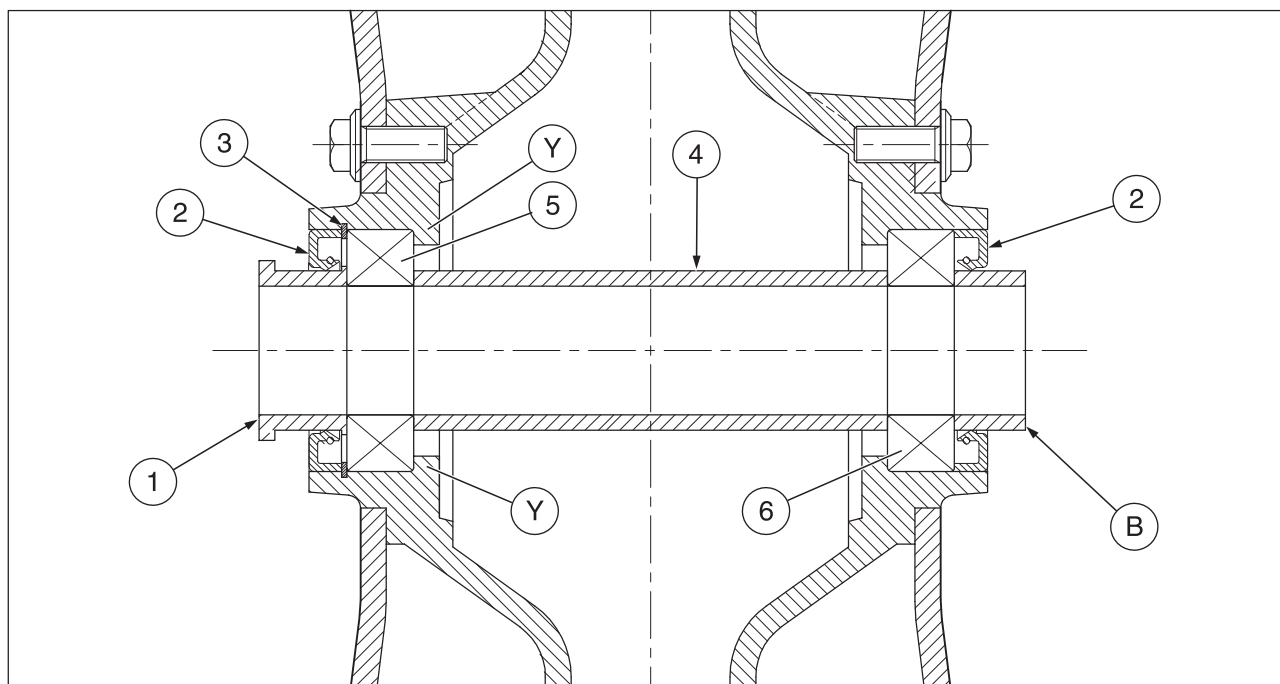
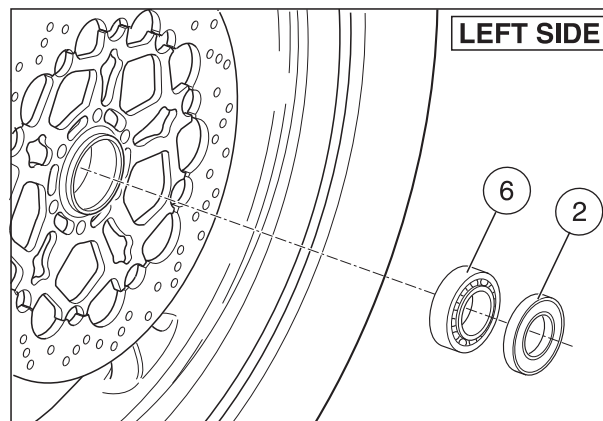
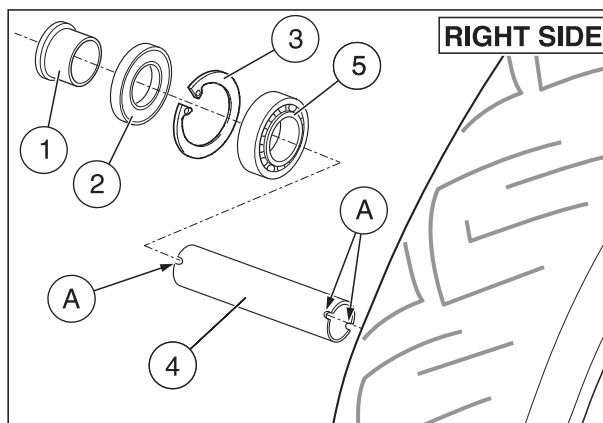

7.2.10 ASSEMBLING THE FRONT WHEEL BEARINGS

If provided:

- ◆ Remove the front wheel bearings, see 7.2.9 (DISASSEMBLING THE FRONT WHEEL BEARINGS).

Work on the right side of the wheel:

NOTE Have the appropriate special tool **OPT** to hand:
 – aprilia part# 8140180 (bearing extractors).

- ◆ Using the appropriate pad, insert the right bearing (5) completely.

NOTE The right bearing must be inserted until its contact with the wheel hub shoulder is complete (Y).

- ◆ Insert the elastic ring (3).

NOTE The elastic ring (3) is provided only on the right side of the wheel.

Work from the left-hand side of the wheel:

- ◆ Insert the spacer (4).

NOTE Have the appropriate special tool **OPT** to hand:
 – aprilia part# 8140180 (bearing extractors).

- ◆ Use a special pad to insert the left bearing (6).

NOTE The complete insertion of the left bearing (6) will bring the following components into contact:

- right bearing (5);
- spacer (4);
- left bearing (6).

CAUTION

After the contact with the right bearing (5) do not push further, in order to avoid forcing the snap ring (3).

NOTE Once the left bearing (6) has been inserted, check the coaxiality of the following components:

- right bearing (5);
- spacer (4);
- left bearing (6).

- ◆ Install a new seal (2).

Work on the right side of the wheel:

- ◆ Install a new seal (2).
- ◆ Insert the spacer ring (1) with its longer diameter to-

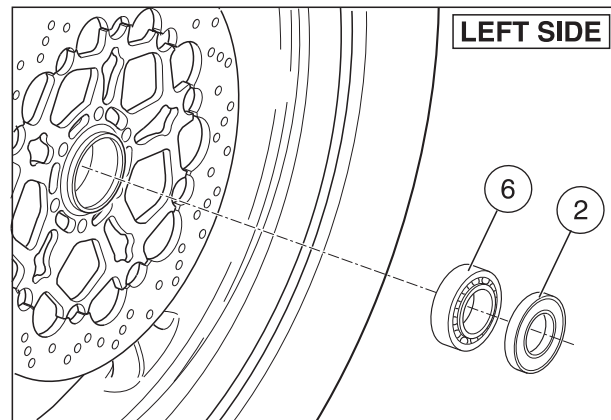
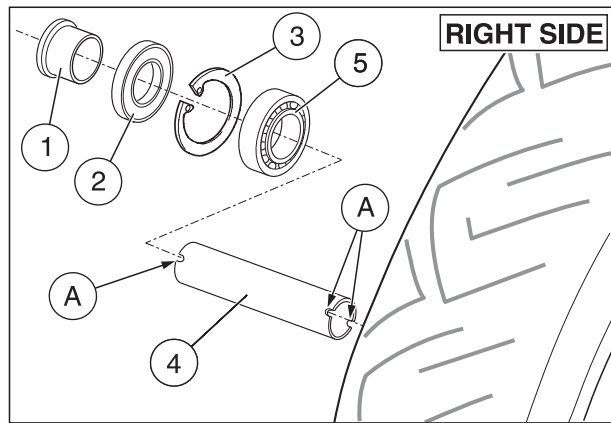

wards the outside of the vehicle.

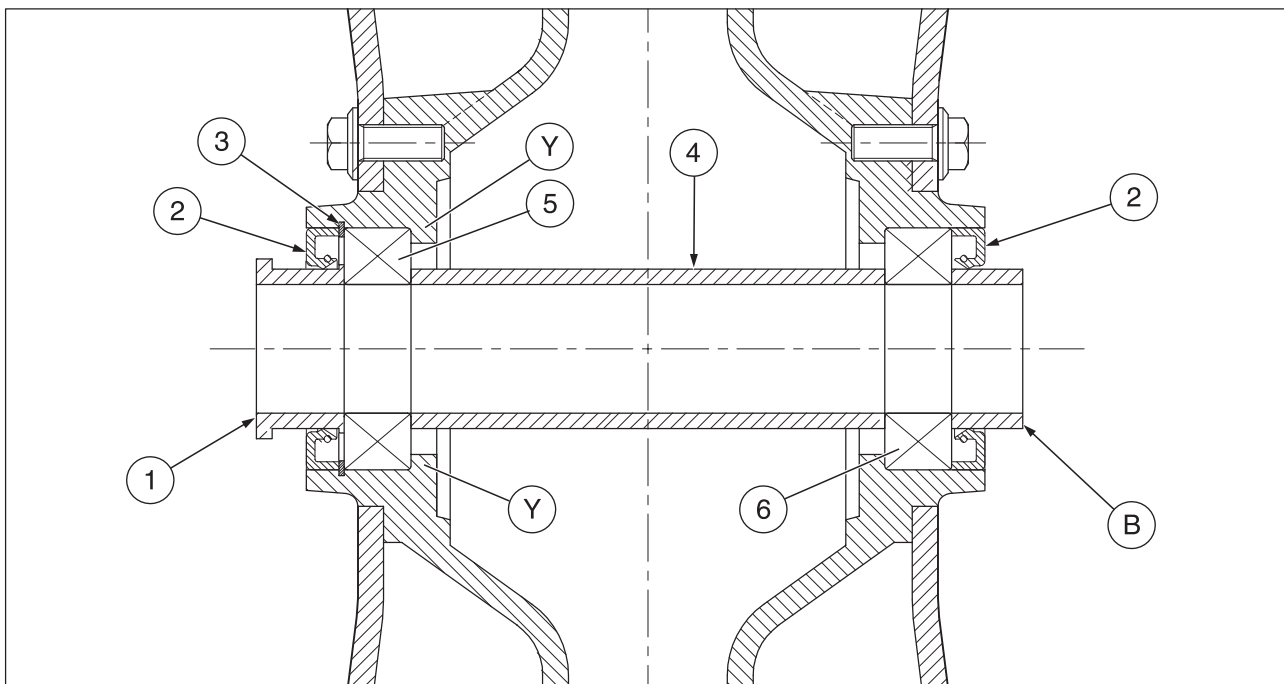

7.2.11 INSTALLING THE FRONT WHEEL

Carefully read 0.5.1 (PRECAUTIONS AND GENERAL INFORMATIONS).

CAUTION

While reassembling the wheel, be careful not to damage the brake pipes, discs and pads. Spread a film of lubricating grease on the whole length of the wheel pin (1), see 1.6 (LUBRICANT CHART).

◆ Up to frame # ZD4MEE009YS000292. Position the left spacer (2) in its seat on the wheel.

NOTE Carry out the operation described below only if the spacer (3) has come off its seat.

◆ Insert the spacer ring (3) with its longer diameter towards the outside of the vehicle.

CAUTION

The arrow on the wheel side indicates the rotation direction.

Upon reassembly, make sure that the wheel is positioned correctly: the arrow must be visible on the left side of the vehicle.

◆ Position the wheel between the fork rods on the support (4).

WARNING

Danger of injury. Do not introduce your fingers to align the holes.

◆ Move the wheel until its central hole and the holes on the fork are aligned.

◆ Introduce the wheel pin (1) completely from the left side.

NOTE Make sure that the wheel pin (1) is completely inserted.

◆ Position the washer (5) and tighten the wheel nut (6) manually.

NOTE In this phase, for the temporary tightening of the two wheel pin clamp screws (7) (left side), the driving torque value need not be respected.

◆ Screw the two wheel pin clamp screws (7) (left side) and tighten them as much as necessary to lock the rotation of the wheel pin (1).

◆ Tighten the wheel nut (6) completely.

Wheel nut (6) driving torque: 80 Nm (8 kgm).

◆ Tighten the two wheel pin clamp screws (8) (right side).

Wheel pin clamp screw driving torque: 22 Nm (2.2 kgm).

◆ Loosen the two wheel pin clamp screws (7) (left side).

◆ Put back the front brake calipers, see 7.5.6 (REMOVING THE FRONT BRAKE CALIPERS).

◆ With pulled front brake lever, press the handlebar repeatedly, thrusting the fork downwards. In this way the fork rods will settle properly.

◆ Position the vehicle on the side stand.

◆ Tighten the two wheel pin clamp screws (7) (left side).

Wheel pin clamp screw (7) driving torque: 22 Nm (2.2 kgm)

◆ Make sure that the following components are not dirty:

- tyre;
- wheel;

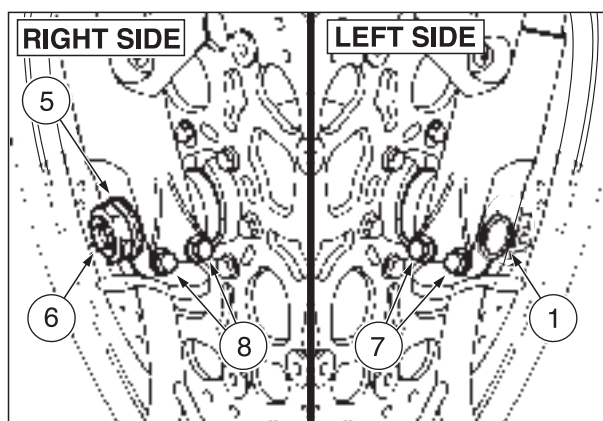
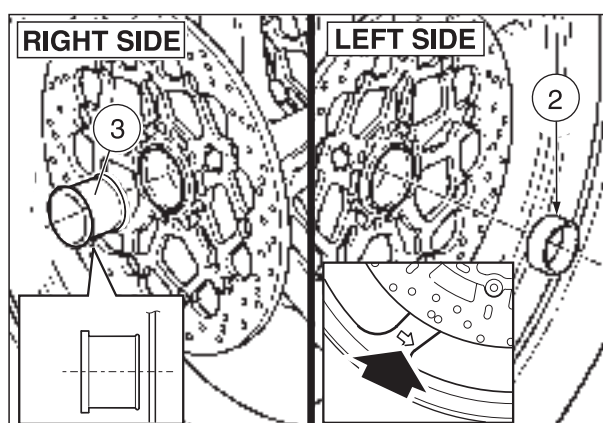
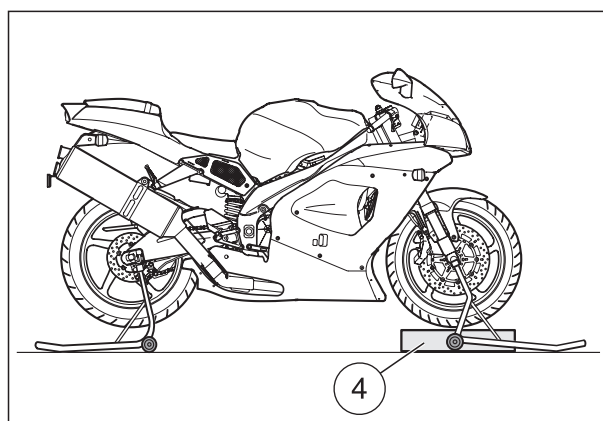

- brake discs.

CAUTION

After reassembly, pull the front brake lever repeatedly and check the correct functioning of the braking system.

Check the wheel centering.

7.3 REAR WHEEL

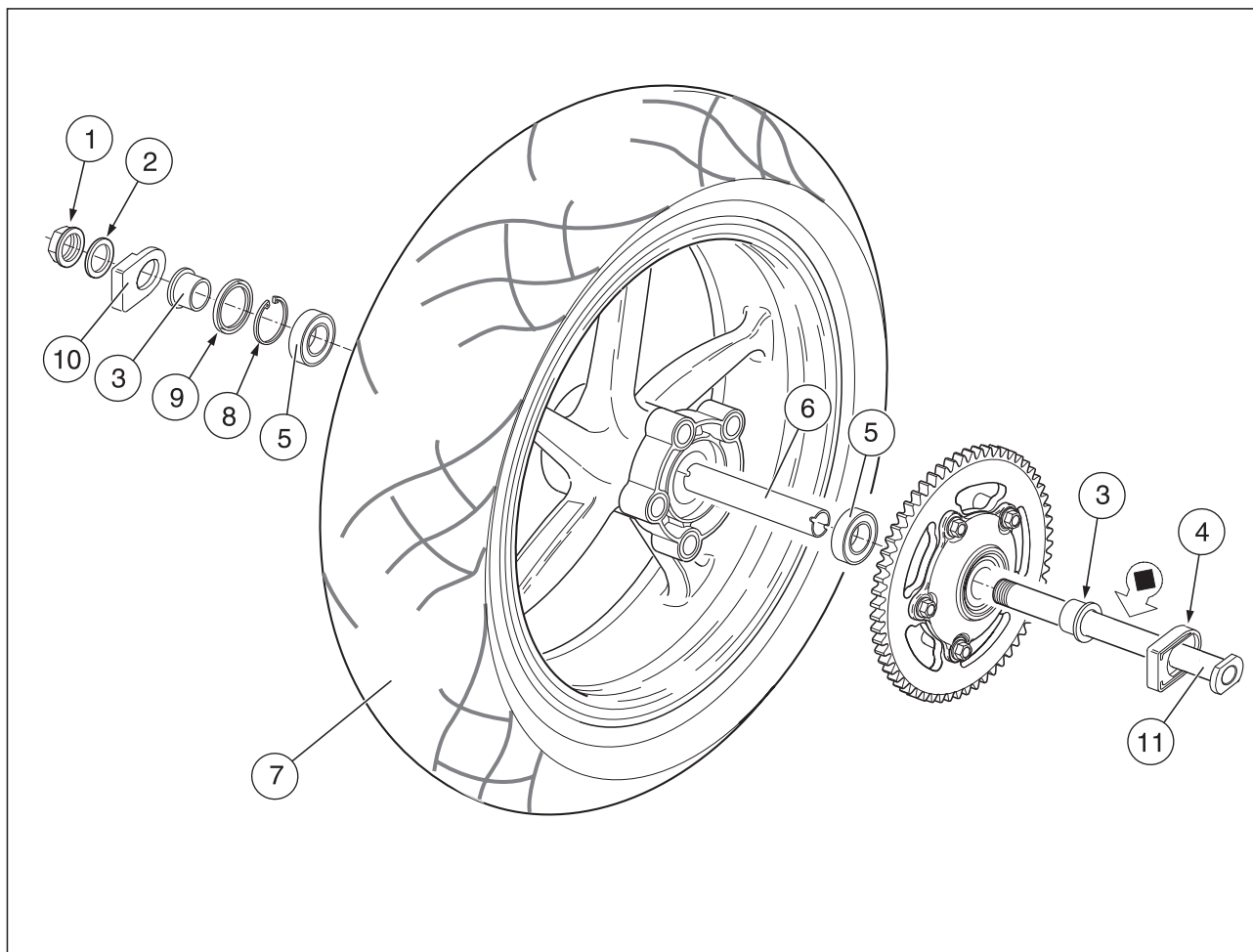

Key

- 1) Nut
- 2) Washer
- 3) Side spacers
- 4) Left chain tightener shoe
- 5) Bearings
- 6) Central spacer
- 7) Complete wheel
- 8) Snap ring
- 9) Seal
- 10) Right chain tightener shoe
- 11) Wheel pin

■ = GREASE, see 1.6 (LUBRICANT CHART).

7.3.1 REMOVING THE REAR WHEEL

Carefully read 0.5.1 (PRECAUTIONS AND GENERAL INFORMATIONS) and 2.34 (REAR WHEEL).

⚠ WARNING

Wait until the engine and the exhaust silencer have completely cooled down.

While disassembling and reassembling the wheel, be careful not to damage the brake pipe, the disc and the pads.

- ◆ Position the vehicle on the appropriate rear support stand, see 1.8.2 (POSITIONING THE VEHICLE ON THE REAR SUPPORT STAND **OPT**)
- ◆ Put a support (2) under the tyre, in such a way as to keep the wheel in its position after loosening it.
- ◆ Slacken the drive chain completely, see 2.36.3 (ADJUSTING THE DRIVING CHAIN).

Wheel nut (3) driving torque: 120 Nm (12 kgm).

- ◆ Loosen and remove the wheel nut (3), taking the washer (4).

NOTE To facilitate the extraction of the wheel pin, slightly raise the wheel.

- ◆ Withdraw the wheel pin (5) from the left side.

NOTE Check the arrangement of the right (6) and left (7) chain tighteners, in order to be able to reassemble them correctly.

- ◆ Take the right (6) and left (7) chain tighteners.

NOTE Lower the drive chain (8) outside the crown gear (9).

- ◆ Make the wheel advance and release the drive chain (8) from the crown gear (9).
- ◆ Withdraw the wheel from the rear fork from behind, carefully withdrawing the disc from the brake caliper.

⚠ CAUTION

Do not operate the rear brake lever after removing the wheel, since the pins may go out of their seats and cause brake fluid leakages.

⚠ CAUTION

The left (10) and right spacer rings (11) remain positioned in the respective seats on the wheel; if they should come off, reposition them correctly.

NOTE The support plate (12) of the brake caliper (13) remains positioned on the right side of the rear fork.

Proceed with care. If the final drive unit (14) is installed on the flexible coupling holder (15), do not overturn or rotate the rear wheel in horizontal position on the rear sprocket side (A), since the final drive unit would come off and fall down, with the risk of damaging the rear sprocket (9).

NOTE The removal of the final drive unit isn't necessary if the wheel is in the normal running position (vertical) or in horizontal position with the rear sprocket facing upwards and in both cases secured against overturning.

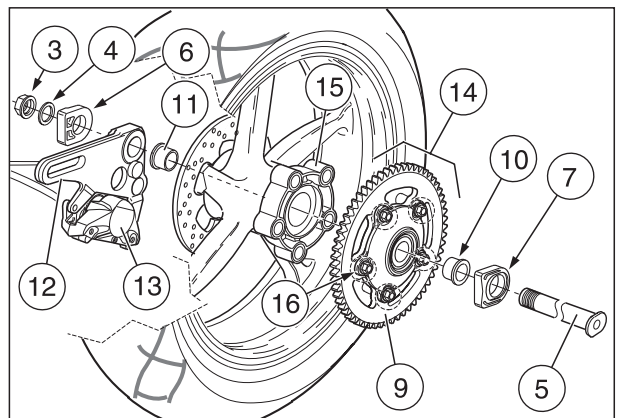
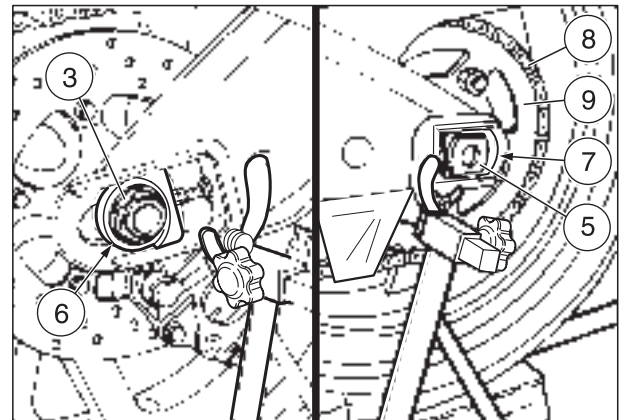
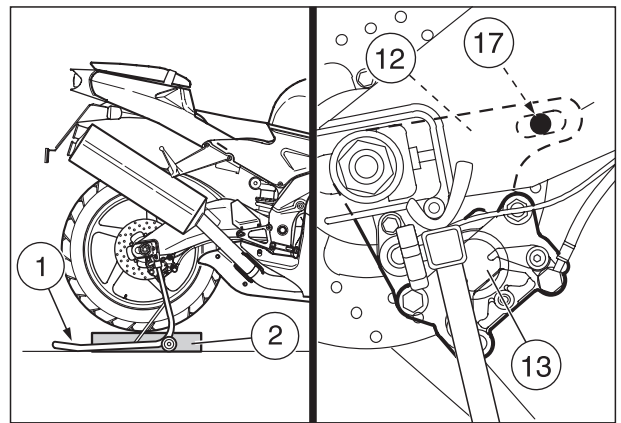

NOTE Do not unscrew the five nuts (16). The whole final drive unit must be withdrawn from the flexible coupling holder.

- ◆ Working (B) with both hands on the outer diameter of the sprocket (9), withdraw the final drive unit parallelly to the wheel axis.
- ◆ Check the state of repair of the components, see 7.3.3 (CHECKING THE REAR WHEEL COMPONENTS).

7.3.2 REMOVING THE FINAL DRIVE UNIT

Carefully read 0.5.1 (PRECAUTIONS AND GENERAL INFORMATIONS).

- ◆ Remove the rear wheel, see 7.3.1 (REMOVING THE REAR WHEEL).

CAUTION

Proceed with care. If the final drive unit (1) is installed on the flexible coupling holder (2), do not overturn or rotate the rear wheel in horizontal position on the rear sprocket side (A), since the final drive unit would come off and fall down, with the risk of damaging the rear sprocket (3).

NOTE Do not unscrew the five nuts (4). The whole final drive unit must be withdrawn from the flexible coupling holder.

- ◆ Working (B) with both hands on the outer diameter of the sprocket (3), withdraw the final drive unit parallelly to the wheel axis.

REASSEMBLY

NOTE Introduce the final drive unit, parallelly to the wheel axis, inserting the flexible couplings (5) in the corresponding seats on the flexible coupling holder (2).

- ◆ Working (C) with both hands on the outer diameter of the sprocket (3), insert the final drive unit in the flexible coupling holder (2).

NOTE Perform the operation described below only if the left (6) and/or the right spacer ring (7) have come off their seats.

- ◆ Insert the left (6) and/or the right spacer ring (7) in the respective seats, with the longer diameter towards the outside of the vehicle.

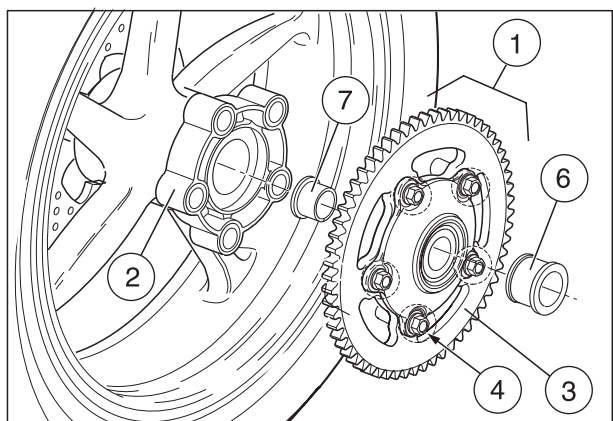
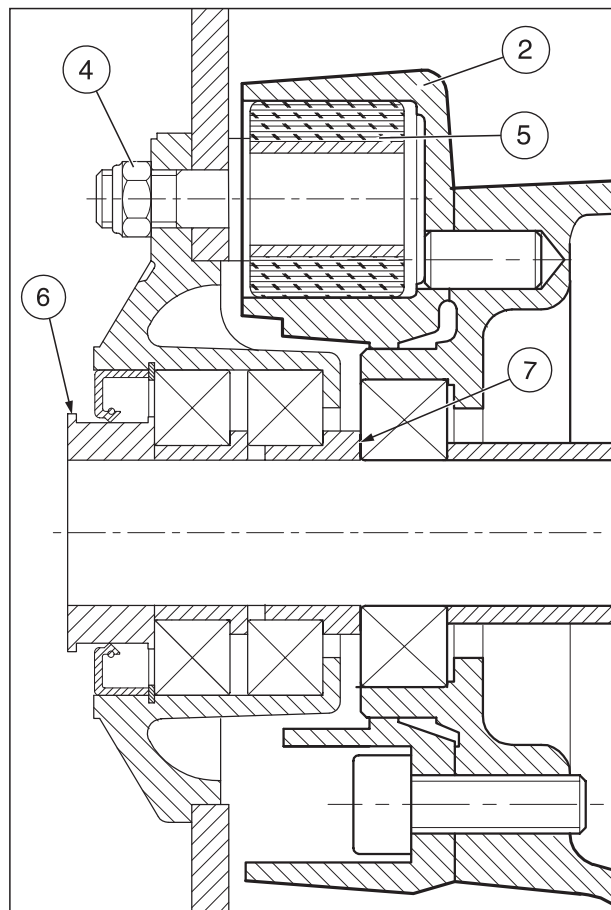
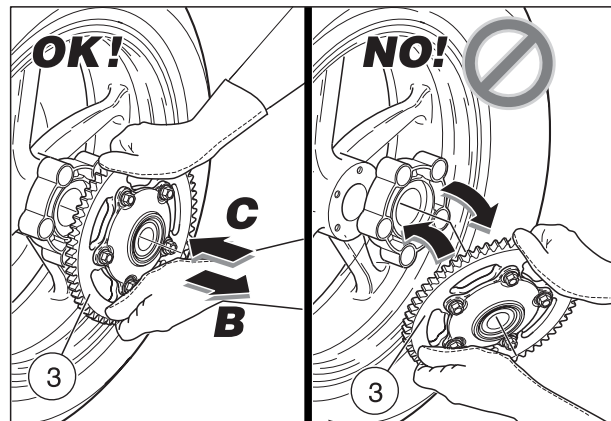
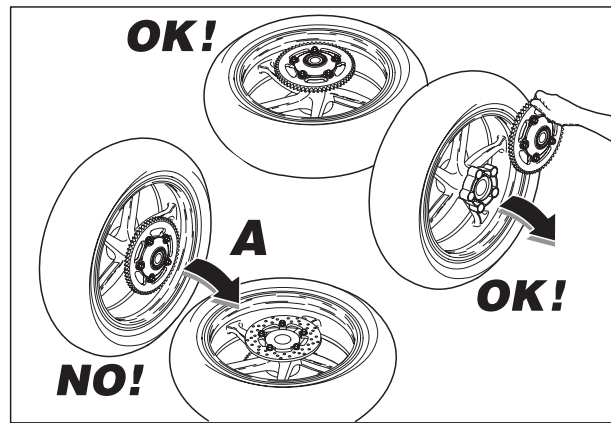

7.3.3 CHECKING THE REAR WHEEL COMPONENTS

CAUTION

Make sure that all the components are intact, particularly the following.

7.3.4 REAR WHEEL BEARINGS

Carry out the check with the bearings mounted on the wheel.

CHECKING THE ROTATION

- ◆ Manually rotate the inner ring of each single bearing. The rotation must be regular, smooth and noiseless.

If one or both bearings is/are not in compliance with the check parameters:

- ◆ Change both wheel bearings, see 7.3.14 (ASSEMBLING THE REAR WHEEL BEARINGS).

WARNING

Always change both bearings.

Always replace the bearings with bearings of the same type.

CHECKING THE END AND RADIAL PLAY

- ◆ Check the radial play and the end play.

End play: a minimum end play is allowed.

Radial play: none.

If one or both bearings is/are not in compliance with the check parameters:

- ◆ Change both wheel bearings, see 7.3.14 (ASSEMBLING THE REAR WHEEL BEARINGS).

WARNING

Always change both bearings.

Always replace the bearings with bearings of the same type.



7.3.5 REAR WHEEL GASKETS

- ◆ Make sure the seals are intact; should they prove damaged or feature signs of excessive wear, change them.

⚠ WARNING

Always change both seals.

Always replace the gaskets with gaskets of the same type.

7.3.6 REAR WHEEL PIN

- ◆ Check the eccentricity of the pin wheel (1) by means of a comparator. If the eccentricity exceeds the limit value, change the pin wheel (1).

Maximum eccentricity: 0.25 mm.

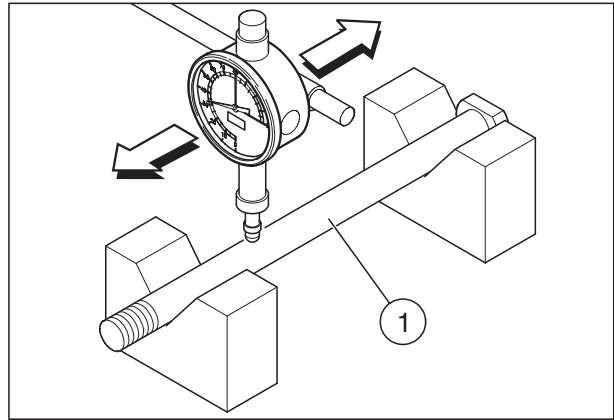

7.3.7 REAR WHEEL RIM

- ◆ Using a comparator, make sure that the radial (A) and axial (B) eccentricity of the rim (2) do not exceed the limit value.

Excessive eccentricity is usually caused by worn or damaged bearings.

If, after changing the bearings, the value does not fall within the indicated limit, change the rim (2).

Maximum radial and axial eccentricity: 2 mm.

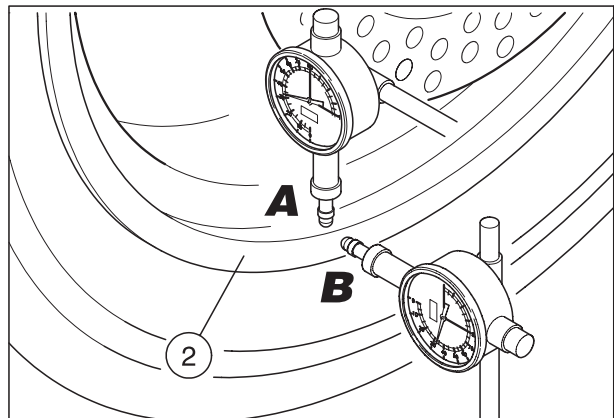

7.3.8 REAR TYRE

- ◆ Check the state of the tyre, see 2.37 (TYRES) and 7.4 (TYRES).

7.3.9 REAR BRAKE DISCS

- ◆ Check the rear brake discs, see 7.6.2 (CHECKING THE REAR BRAKE DISC).

7.3.10 FINAL DRIVE UNIT BEARINGS

Carry out the check with the bearings mounted on the final drive unit.

CHECKING THE ROTATION

- ◆ Remove the left spacer (1).
- ◆ Remove the right spacer (2).
- ◆ Manually rotate the inner ring of each single bearing. The rotation must be regular, smooth and noiseless.

If one or both bearings is/are not in compliance with the check parameters:

- ◆ Change both final drive unit bearings, see 7.3.16 (ASSEMBLING THE FINAL DRIVE UNIT BEARINGS).

⚠ WARNING

Always change both bearings.

Always replace the bearings with bearings of the same type.

CHECKING THE END AND RADIAL PLAY

- ◆ Check the radial play and the end play.
 - End play: a minimum end play is allowed.**
 - Radial play: none.**

If one or both bearings is/are not in compliance with the check parameters:

- ◆ Change both final drive unit bearings, see 7.3.16 (ASSEMBLING THE FINAL DRIVE UNIT BEARINGS).

⚠ WARNING

Always change both bearings.

Always replace the bearings with bearings of the same type.

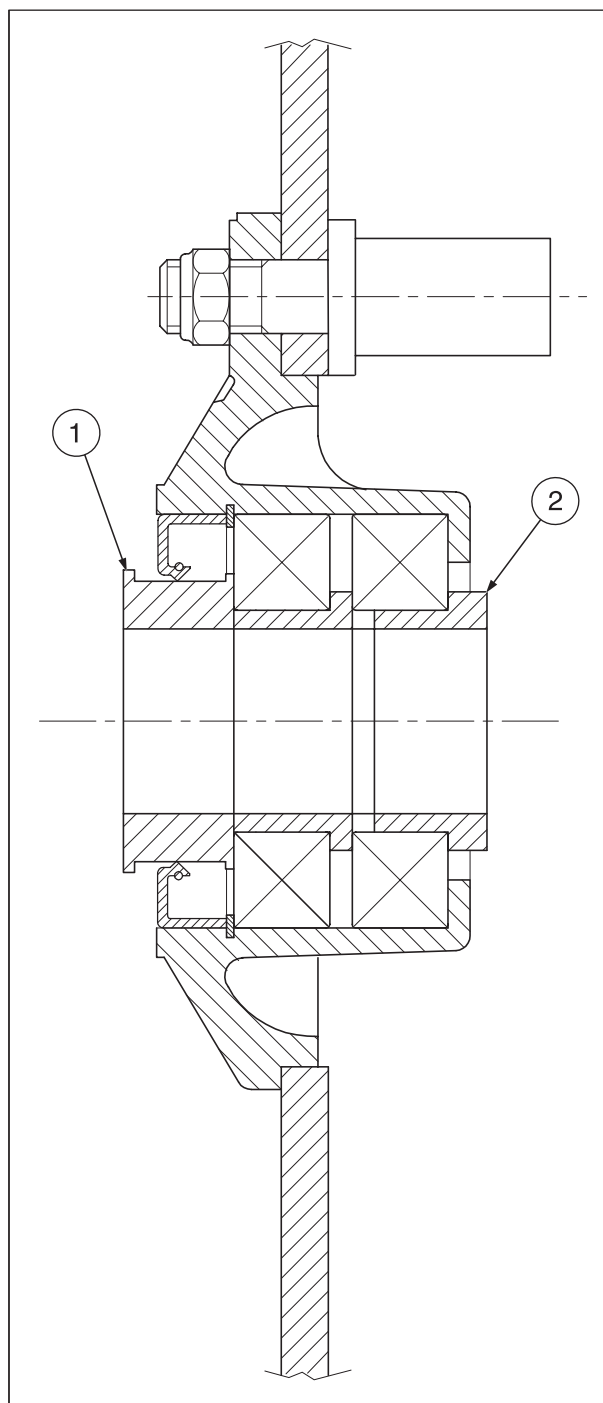

7.3.11 FLEXIBLE COUPLINGS

◆ Make sure the rubber elements (1) of the flexible couplings are not damaged and/or feature excessive wear.

To carry out the check:

- ◆ Fit the whole final drive unit complet (2) on the wheel.
- ◆ Manually rotate the crown gear (3) in both directions and check the slack between the flexible coupling rubber elements (1) and the flexible coupling holder (4).

If slack is excessive:

- ◆ Change all the flexible coupling rubber elements (1), see 7.3.17 (REMOVING THE FLEXIBLE COUPLINGS).

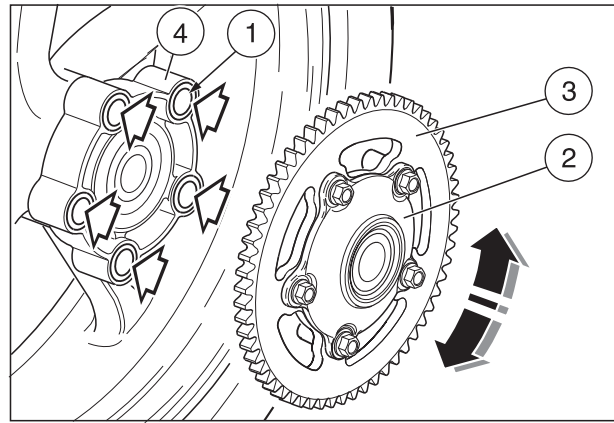

⚠ WARNING

Always replace the flexible couplings with ones of the same type.

7.3.12 SPROCKET

◆ Check the conditions of the sprocket teeth (3).

If there are signs of excessive wear:

- ◆ Change the crown gear, see 7.3.18 (REMOVING THE CROWN GEAR), the drive pinion, see 7.1.53 (REMOVING THE DRIVE PINION) and the drive chain, see 7.11 (DISASSEMBLING THE DRIVING CHAIN).



⚠ CAUTION

To avoid the untimely wear of the new components, crown, pinion and drive chain must be replaced all together.

7.3.13 DISASSEMBLING THE REAR WHEEL BEARINGS

Carefully read 0.5.1 (PRECAUTIONS AND GENERAL INFORMATIONS).

- ◆ Remove the rear wheel, see 7.3.1 (REMOVING THE REAR WHEEL).
- ◆ Use a cloth to clean both sides of the hub.

Work on the right side of the wheel:

- ◆ Remove the right spacer (1).
- ◆ Remove the seal (2).
- ◆ Remove the snap ring (3).

NOTE The elastic ring (3) is provided only on the right side of the wheel.

The ends of the spacer (4) are provided with slots (A) to allow the passage of the extractor teeth.

NOTE Have the appropriate special tool **OPT** to hand:
– **aprilia** part# 8140180 (bearing extractors).

- ◆ Use a special extractor to extract the right bearing (5).
- ◆ Retrieve the inner spacer (4).

Work from the left-hand side of the wheel:

NOTE Have the appropriate special tool **OPT** to hand:
– **aprilia** part# 8140180 (bearing extractors).

- ◆ Use a special extractor to extract the left bearing (6).
- ◆ Thoroughly clean the inside of the hub.

NOTE Wash all the components with a clean detergent.

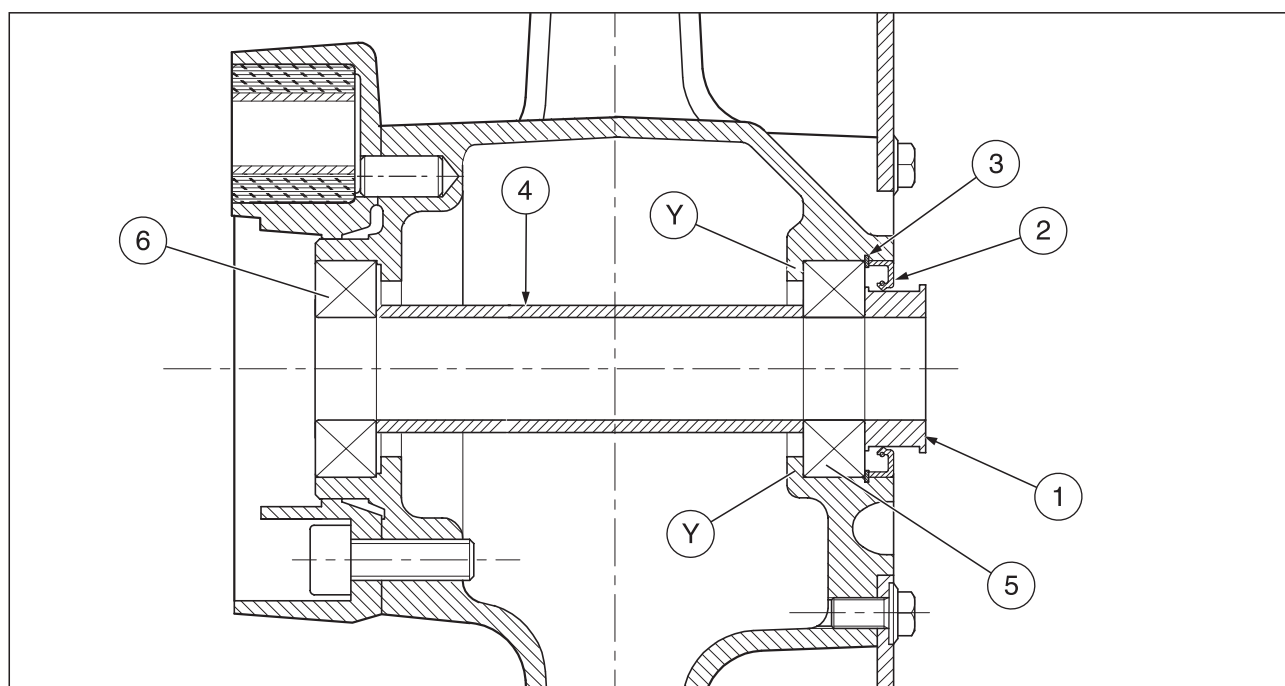
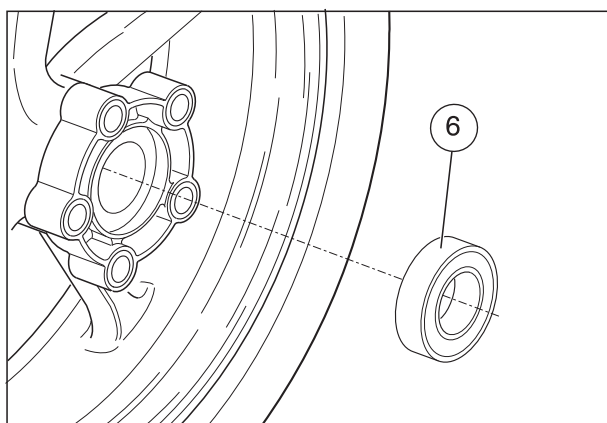
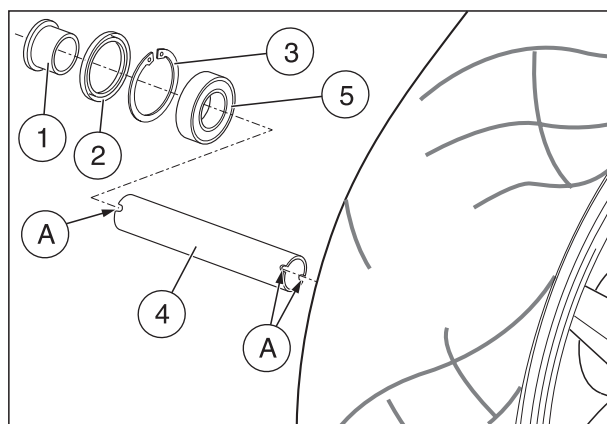

7.3.14 ASSEMBLING THE REAR WHEEL BEARINGS

If provided:

- ◆ Remove the rear wheel bearings, see 7.3.13 (DISASSEMBLING THE REAR WHEEL BEARINGS).

Work on the right side of the wheel:

NOTE Have the appropriate special tool **OPT** to hand:
 – aprilia part# 8140180 (bearing extractors).

- ◆ Using the appropriate pad, insert the right bearing (5) completely.

NOTE The right bearing must be inserted until its contact with the wheel hub shoulder is complete (Y).

- ◆ Insert the elastic ring (3).

NOTE The elastic ring (3) is provided only on the right side of the wheel.

Work from the left-hand side of the wheel:

- ◆ Insert the spacer (4).

NOTE Have the appropriate special tool **OPT** to hand:
 – aprilia part# 8140180 (bearing extractors).

- ◆ Use a special pad to insert the left bearing (6).

NOTE The complete insertion of the left bearing (6) will bring the following components into contact:

- right bearing (5);
- spacer (4);
- left bearing (6).

CAUTION

After the contact with the right bearing (5) do not push further, in order to avoid forcing the snap ring (3).

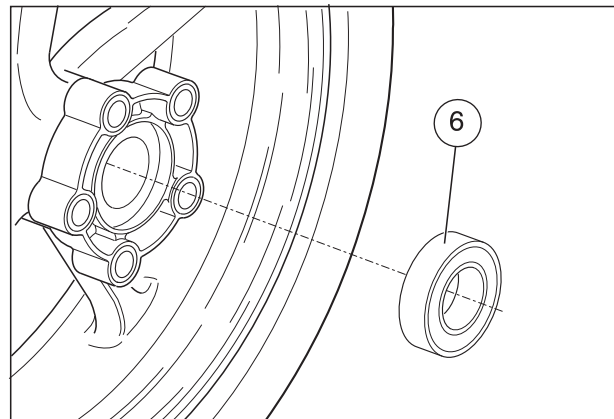
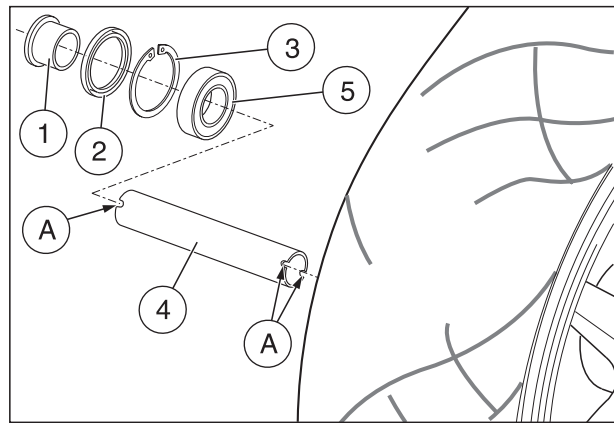

NOTE Once the left bearing (6) has been inserted, check the coaxiality of the following components:

- right bearing (5);
- spacer (4);
- left bearing (6).

Work from the right-hand side:

- ◆ Install a new seal (2).
- ◆ Insert the spacer ring (1) with its larger diameter towards the outside of the vehicle.

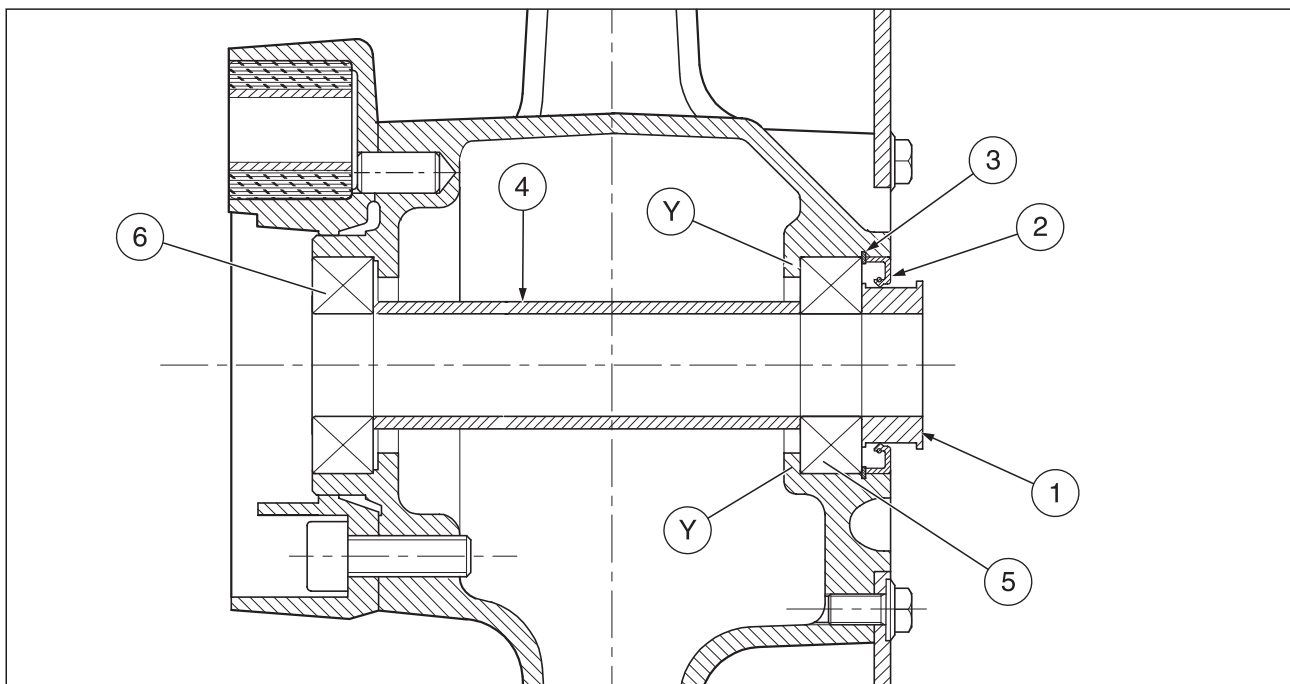

7.3.15 DISASSEMBLING THE FINAL DRIVE UNIT BEARINGS

Carefully read 0.5.1 (PRECAUTIONS AND GENERAL INFORMATIONS).

- ◆ Remove the final drive unit, see 7.3.2 (REMOVING THE FINAL DRIVE UNIT).
- ◆ Use a cloth to clean both sides of the hub.
- ◆ Remove the left spacer (1).
- ◆ Remove the seal (2).
- ◆ Remove the snap ring (3).

NOTE The elastic ring (3) is provided only on the left side of the final drive unit.

NOTE Have the appropriate special tool **OPT** to hand:
– **aprilia** part# 8140180 (bearing extractors).

- ◆ Use a special extractor to extract the left bearing (4).
- ◆ Retrieve the inner spacer (5).
- ◆ Use a special extractor to extract the right bearing (6).
- ◆ Take the right spacer ring (7).
- ◆ Thoroughly clean the inside of the hub.

NOTE Wash all the components with a clean detergent.

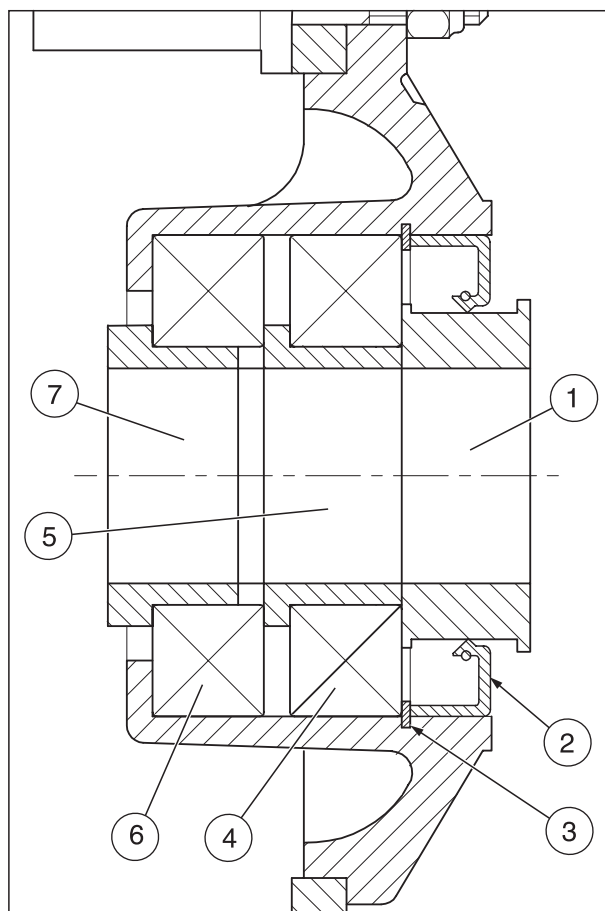
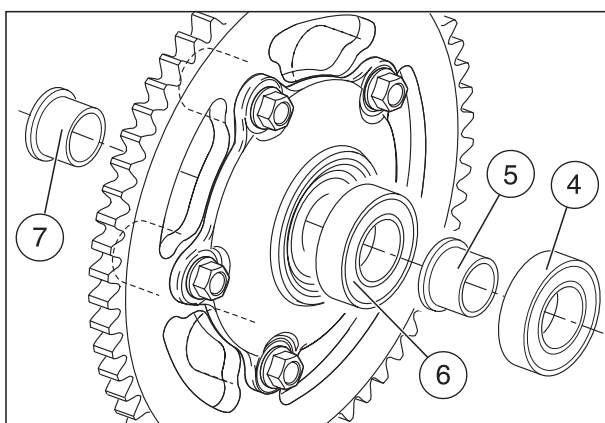
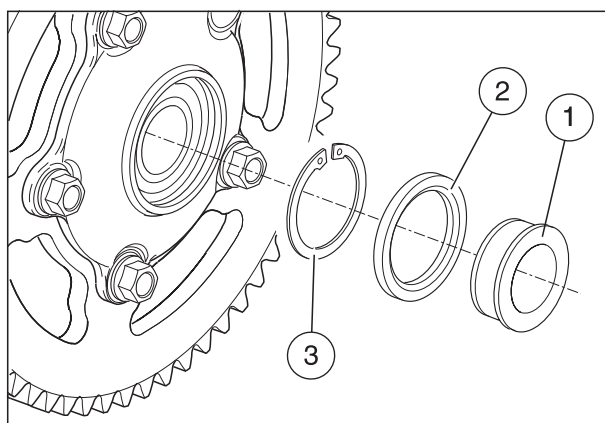

7.3.16 ASSEMBLING THE FINAL DRIVE UNIT BEARINGS

If provided:

- ◆ Remove the final drive unit bearings, see 7.3.15 (DIS-ASSEMBLING THE FINAL DRIVE UNIT BEARINGS).

Work from the left-hand side:

NOTE Have the appropriate special tool **OPT** to hand:

- aprilia part# 8140180 (bearing extractors).
- ◆ Using the appropriate pad, insert the right bearing (6) completely.

NOTE The right bearing must be inserted until its contact with the wheel hub shoulder is complete (Y).

- ◆ Insert the inner spacer (5).
- ◆ Use a special pad to insert the left bearing (4).

NOTE The complete insertion of the left bearing (4) will bring the following components into contact:

- right bearing (6);
- inner spacer (5);
- left bearing (4).

- ◆ Insert the elastic ring (3).

NOTE The elastic ring (3) is provided only on the left side of the final drive unit.

- ◆ Install a new seal (2).
- ◆ Insert the left (1) with the longer diameter towards the outside of the vehicle.

Work from the right-hand side:

- ◆ Insert the right spacer (7) with the longer diameter towards the outside of the vehicle.

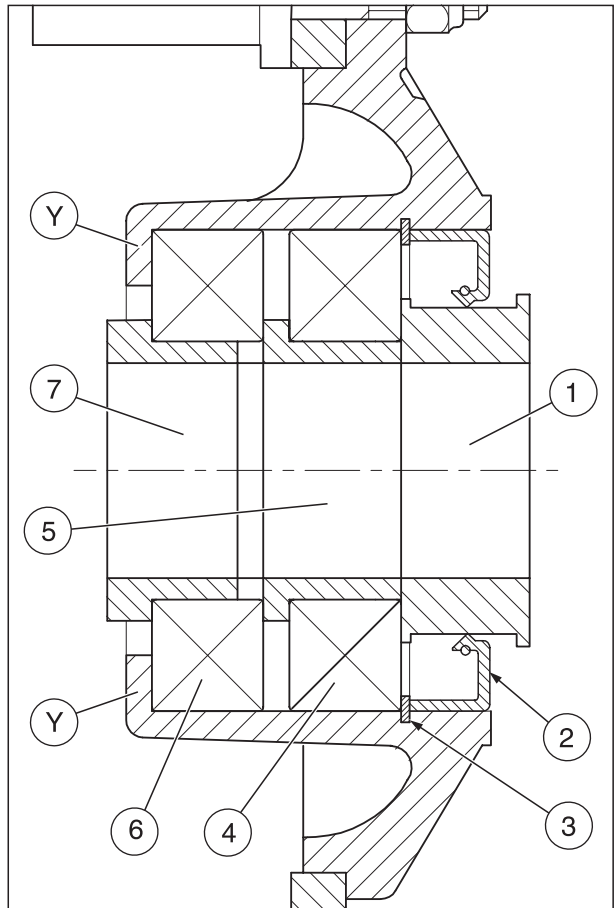
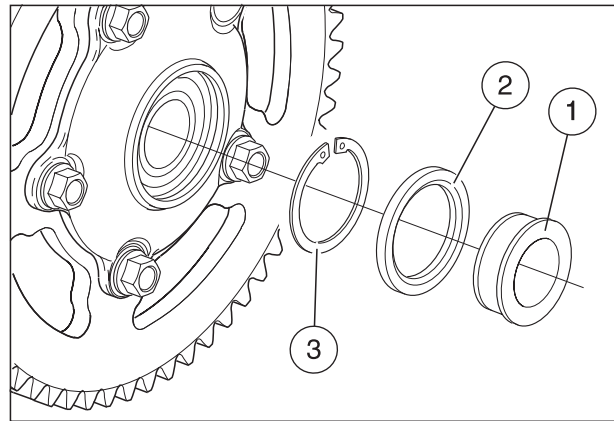
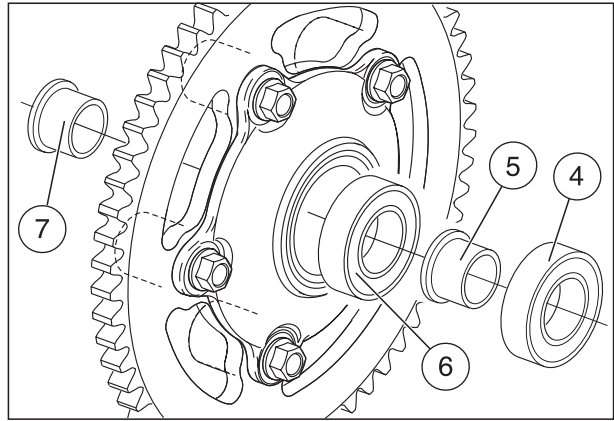

7.3.17 REMOVING THE FLEXIBLE COUPLINGS

Carefully read 0.5.1 (PRECAUTIONS AND GENERAL INFORMATIONS).

- ◆ Remove the final drive unit, see 7.3.2 (REMOVING THE FINAL DRIVE UNIT).

NOTE The flexible couplings remain installed on the flexible coupling holder.

- ◆ Extract all the flexible coupling rubber elements.

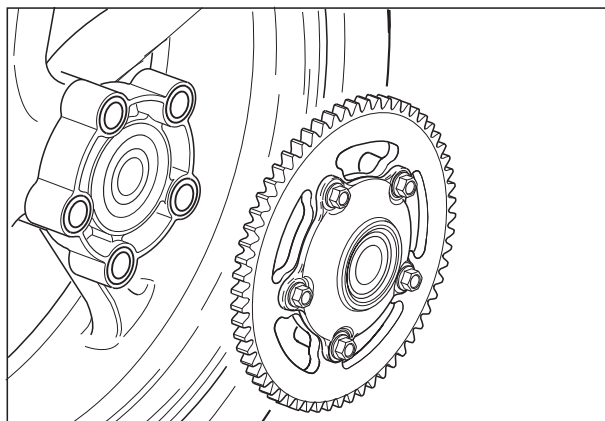

7.3.18 REMOVING THE CROWN GEAR

Carefully read 0.5.1 (PRECAUTIONS AND GENERAL INFORMATIONS).

Crown gear self-locking nuts driving torque: 50 Nm (5.0 kgm).

- ◆ Working on the appropriate seat (1) with an hexagon spanner, lock the threaded pin (2), unscrew and remove the self-locking nut (3) and the threaded pin (2).

⚠ CAUTION

The self-locking nuts (3) must be replaced every three removals of the sprocket.

Replace the self-locking nuts (3) with nuts of the same type.

- ◆ Remove the crown holder (4).
- ◆ Clean the crown gear (5) and the crown holder (4) with clean detergent.

Reassembly:

- ◆ Insert the five threaded pins (2) in the sprocket (5).
- ◆ Assemble the sprocket holder on the sprocket-threaded pins unit.
- ◆ Screw the five self-locking nuts (3) manually.

⚠ CAUTION

It is forbidden to install the final drive unit (6) on the wheel to tighten the self-locking nuts.

⚠ CAUTION

To protect the crown gear, install guards (in wood or aluminium) on the vice jaws. Lock only the crown gear in the vice, be careful not to lock any other component of the final drive unit.

- ◆ Lock the crown gear in the vice.

NOTE To avoid any deformation and/or incorrect coupling, carry out the tightening as described below:

- ◆ Working on the appropriate seat (1) with an hexagon spanner, lock the threaded pin (2) and, applying half the prescribed driving torque, tighten the diametrically opposite elements in the given order: (A) (B) (C) (D) (E).
- ◆ Repeat the previous operation by applying the prescribed driving torque.

NOTE In this way the pressure exerted by the fastening elements will be uniformly distributed on the joint surface.

Self-locking nut (3) driving torque: 50 Nm (5.0 kgm).

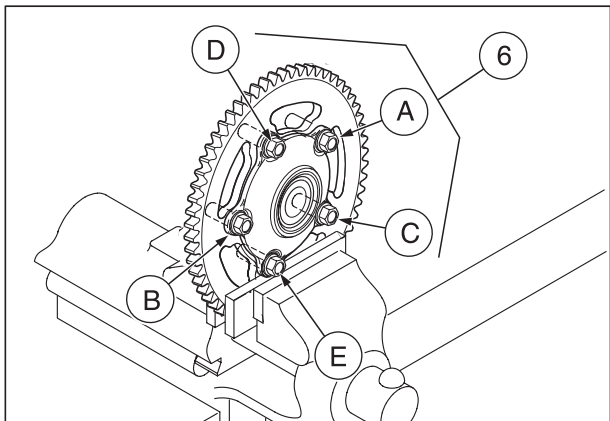
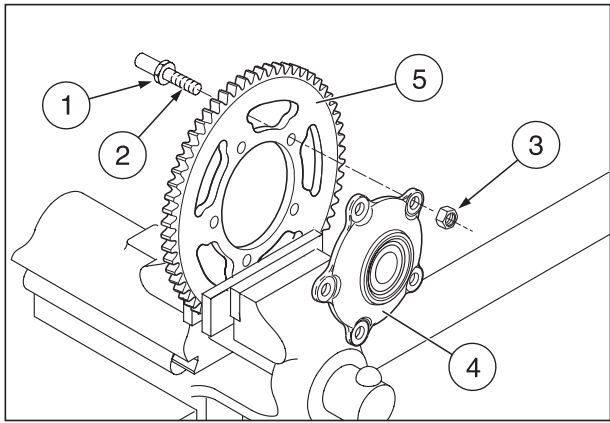

7.3.19 REMOVING THE FLEXIBLE COUPLING HOLDER RSV

Carefully read 0.5.1 (PRECAUTIONS AND GENERAL INFORMATIONS).

- ◆ Remove the final drive unit, see 7.3.2 (REMOVING THE FINAL DRIVE UNIT).

Flexible coupling holder screw (1) driving torque: 50 Nm (5.0 kgm).

- ◆ Unscrew and remove the five screws (1) of the flexible coupling holder.
- ◆ Remove the flexible coupling holder (2).

NOTE The flexible couplings remain installed on the flexible coupling holder.

Reassembly:

A centering pin (3) is provided to ensure the coaxiality of the flexible coupling holder with the wheel axis.

- ◆ Correctly install the flexible coupling holder on the wheel rim.
- ◆ Manually screw the five screws (2) of the flexible coupling holder.
- ◆ Applying half the prescribed driving torque, tighten the elements that are diametrically opposite each other: (A) (B) (C) (D) (E).
- ◆ Repeat the previous operation by applying the prescribed driving torque.

Flexible coupling holder screws driving torque (1): 50 Nm (5.0 kgm).

NOTE In this way the pressure exerted by the fastening elements will be uniformly distributed on the joint surface.

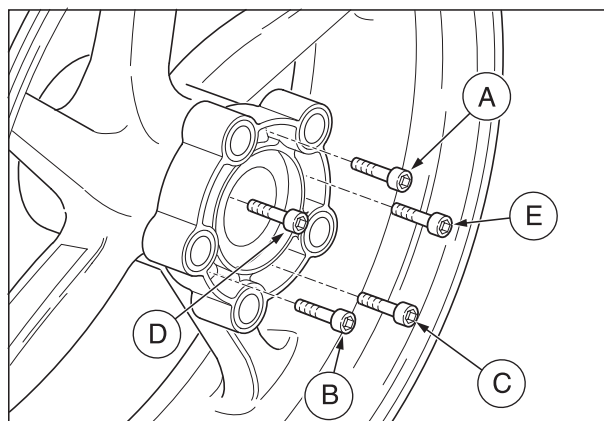
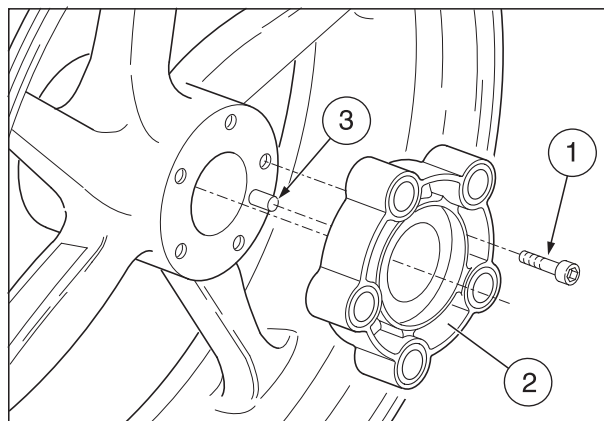

7.3.20 CHANGING THE WHEEL RIM

Carefully read 0.5.1 (PRECAUTIONS AND GENERAL INFORMATIONS).

In case of replacement of the wheel rim, it is necessary to install the following components on the new rim:

CAUTION

Do not remove the centering pin from the rim to be replaced, but always install a new centering pin.

- a new flexible coupling holder centering pin (3);
- the flexible coupling holder (2), which may be the existing one (taken from the replaced rim) or a new one (if the old one is damaged).
- ◆ Remove the flexible coupling holder (2) from the rim to be replaced, see 7.3.19 (REMOVING THE FLEXIBLE COUPLING HOLDER RSV).
- ◆ Install the new centering pin (3) on the new rim.
- ◆ Install the flexible coupling holder (2) (old or new), see 7.3.19 (REMOVING THE FLEXIBLE COUPLING HOLDER RSV).

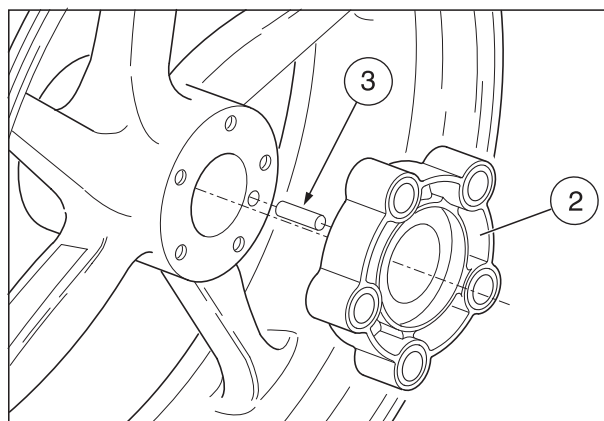

7.3.21 INSTALLING THE REAR WHEEL

Carefully read 0.5.1 (PRECAUTIONS AND GENERAL INFORMATIONS).

If the final drive unit has been removed:

- ◆ Put back the final drive unit, see 7.3.2 (REMOVING THE FINAL DRIVE UNIT).

CAUTION

Before proceeding with the reassembly, make sure that support plate (1) of the brake caliper (2) is positioned correctly; the plate slot must be inserted in the appropriate stop pin (3) in the inner part of the rear fork right rod.

Insert the disc in the brake caliper carefully. When reassembling, take care not to damage the hose, disc, brake pads and speed sensor cable.

- ◆ Spread a film of lubricating grease on the whole length of the wheel pin (4), see 1.6 (LUBRICANT CHART).
- ◆ Position the right (5) and left (6) chain tighteners in their seats on the rear fork arms.
- ◆ Position the wheel between the rear fork rods on the support (7).
- ◆ Make the wheel advance and position the drive chain (8) on the crown gear (9).

CAUTION

Danger of injury. Do not introduce your fingers to align the holes.

- ◆ Move the wheel backwards, until its central hole and the holes on the rear fork are aligned.
- ◆ Rotate the support plate (1), complete with brake caliper (2) and with fulcrum on the stop pin (3), until it is aligned with the holes.
- ◆ Introduce the wheel pin (4) completely from the left side.

NOTE Make sure that the wheel pin (4) is inserted completely, with the head in the appropriate seat on the left chain tightener (6).

- ◆ Position the washer and tighten the nut (10) manually.
- ◆ Check the chain tension, see 2.36.3 (ADJUSTING THE DRIVING CHAIN).
- ◆ Tighten the nut (10).

Wheel nut (10) driving torque: 120 Nm (12.0 kgm).

- ◆ Make sure that the following components are not dirty:
 - tyre;
 - wheel;
 - brake disc.

CAUTION

After reassembly, pull the rear brake lever repeatedly and check the correct functioning of the braking system.

Check the wheel centering.

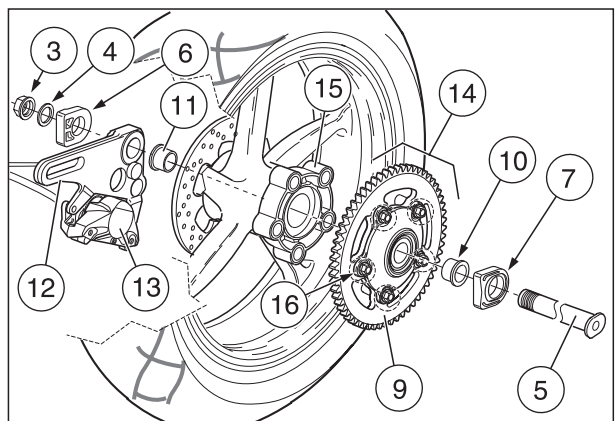
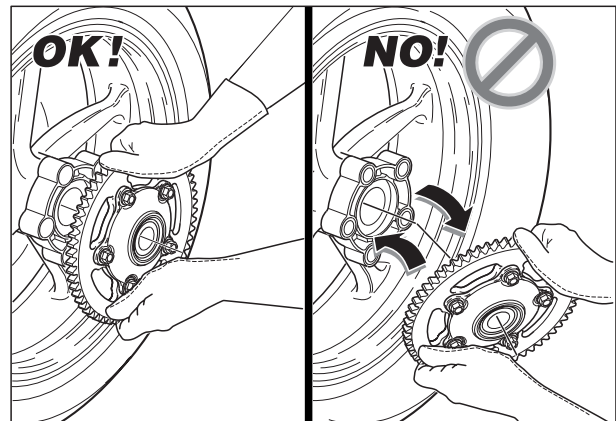
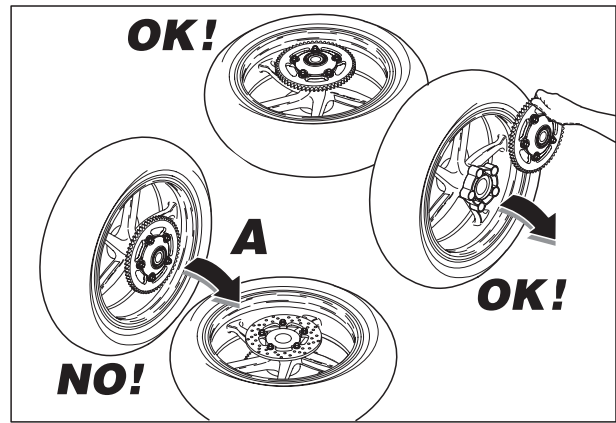

7.4 TYRES

7.4.1 TYRE DISASSEMBLY

Carefully read 0.5.1 (PRECAUTIONS AND GENERAL INFORMATIONS) and 2.37 (TYRES).

- ◆ Unscrew and remove the closing cap (1).
- ◆ Deflate the inner tube completely.
- ◆ Unscrew and remove the valve lock ring (2).

NOTE Mark the tyre with chalk, to show its position with respect to the rim and to the rotation direction.

- ◆ Proceed to the disassembly of the tyre using special equipment and following specific procedures.

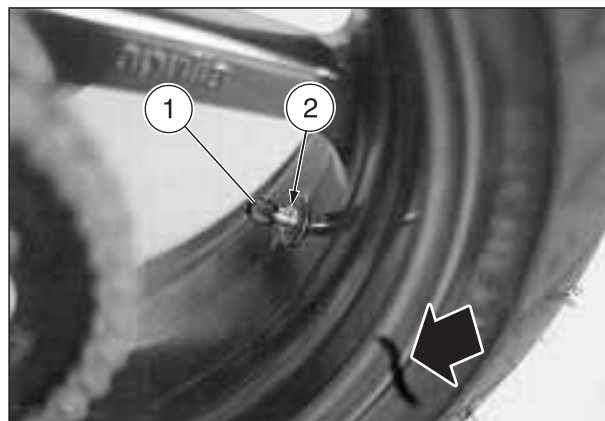

7.4.2 CHECKING THE COMPONENTS

RIM

Before checking the rim, eliminate all rubber or rust residues.

If one or more of the listed defects are present, change the rim.

- Deformation or cracking;
- Marks/lines or defects.

For further information, see 7.2.2 (CHECKING THE FRONT WHEEL COMPONENTS).

TYRE

Thoroughly check the tyre after removing it. If one or more of the listed defects are present, do not repair the tyre, but change it.

- Hole or crack exceeding 5 mm in diameter or length;
- Mark or cracking on the side;
- Tread depth less than 2 mm;
- Ply unglued;
- Separated tread;
- Deformation or wear of tread not uniform;
- Marks/lines on the bead;
- Damage due to skidding (flattened areas);
- Anomalies in the inner seal.

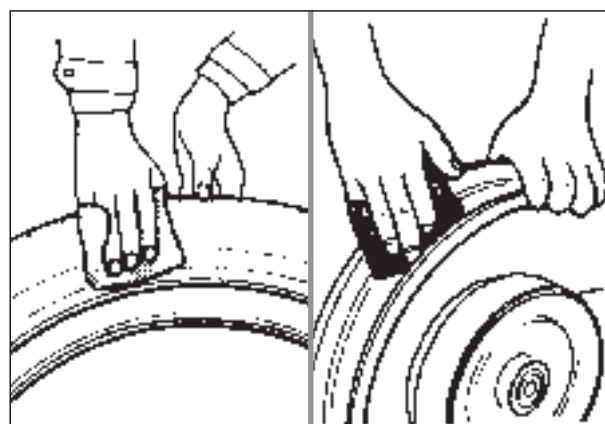

⚠ CAUTION

When repairing a punctured tyre, follow the instructions and use only the components recommended for repairing.

For further information, see 2.37 (TYRES).

7.4.3 ASSEMBLING THE TYRE

- ◆ Eliminate any trace of dirt or rust from the valve seat.
- ◆ Apply the special lubricant for tyres, or soapy water, to the beads of the tyre.

⚠ CAUTION

Never apply grease, oil or petrol to the beads of the tyre for any reason whatsoever.

If a disassembled tyre is to be reassembled, make sure that the arrow stamped on it is pointed in the wheel rotation direction and make the chalk mark made on the tyre upon disassembly coincide with the mark on the rim.

- ◆ Proceed to the assembly of the tyre using special equipment and following specific procedures.

NOTE Before inflating the tyre, make sure that the mark on the tyre still coincides with the mark on the rim.

- ◆ Make the tyre bounce several times and at the same time rotate it (A). This operation pushes the beads towards the seats on the rim, thus facilitating the inflation of the tyre.

⚠ WARNING

The tyre it may explode, causing serious injuries. Never sit on the tyre while inflating it.

- ◆ Slightly inflate the tyre; do not over inflate.

NOTE Check the "line" of the rim on the tyre side. It must be equidistant from the edge of the rim along its entire circumference.

If the distance between the line of the tyre and the rim varies along the circumference, this means that the bead is not positioned properly.

In this case, deflate the tyre completely and separate both beads from the rim.

Spread the special lubricant on the beads and inflate the tyre again.

⚠ WARNING

The tyre it may explode, causing serious injuries. Never sit on the tyre while inflating it.

- ◆ When the tyre is properly installed on the rim, regulate the pressure to the prescribed value, see 1.5 (TECHNICAL SPECIFICATIONS).
- ◆ Check the wheel centering.

⚠ WARNING

Do not exceed 50 km/h in the first 24 hours following the repair of the tyre; the insert or the patch might not be completely glued.

Do not exceed the speed of 130 km/h with a repaired tyre.

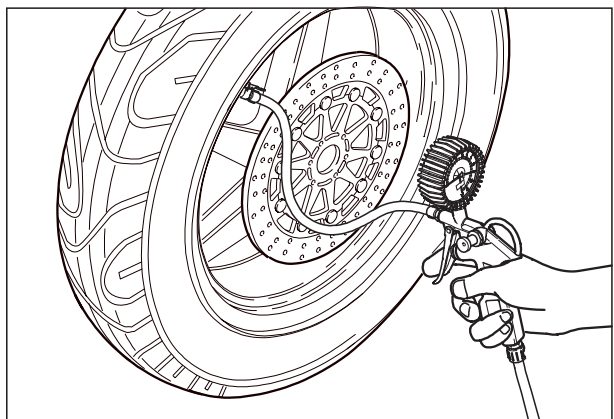
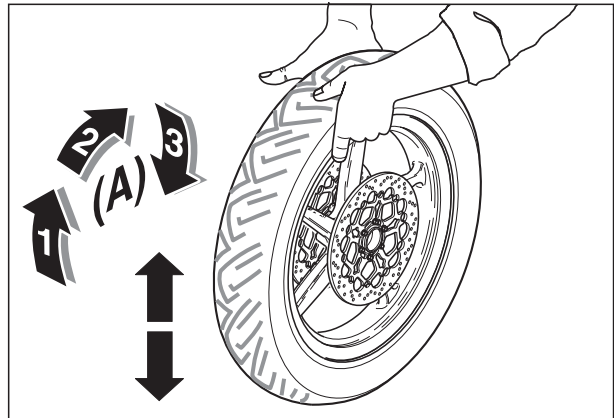
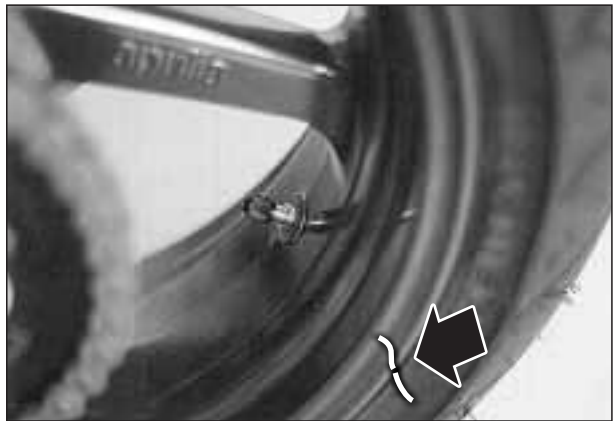
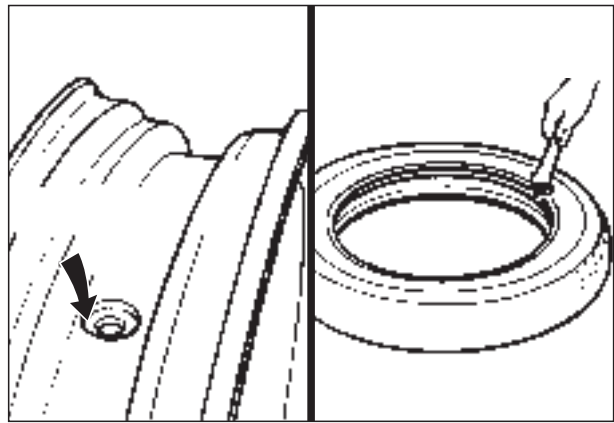

7.5 FRONT BRAKE

NOTE This vehicle is provided with disc brakes with two, front and rear braking systems having separate hydraulic circuits.

The front braking system is with double disc (right and left side).

The front brake fluid tank is positioned on the right part of the handlebar, near the front brake lever coupling.

⚠ WARNING

Do not use the vehicle if the braking system leaks fluid.

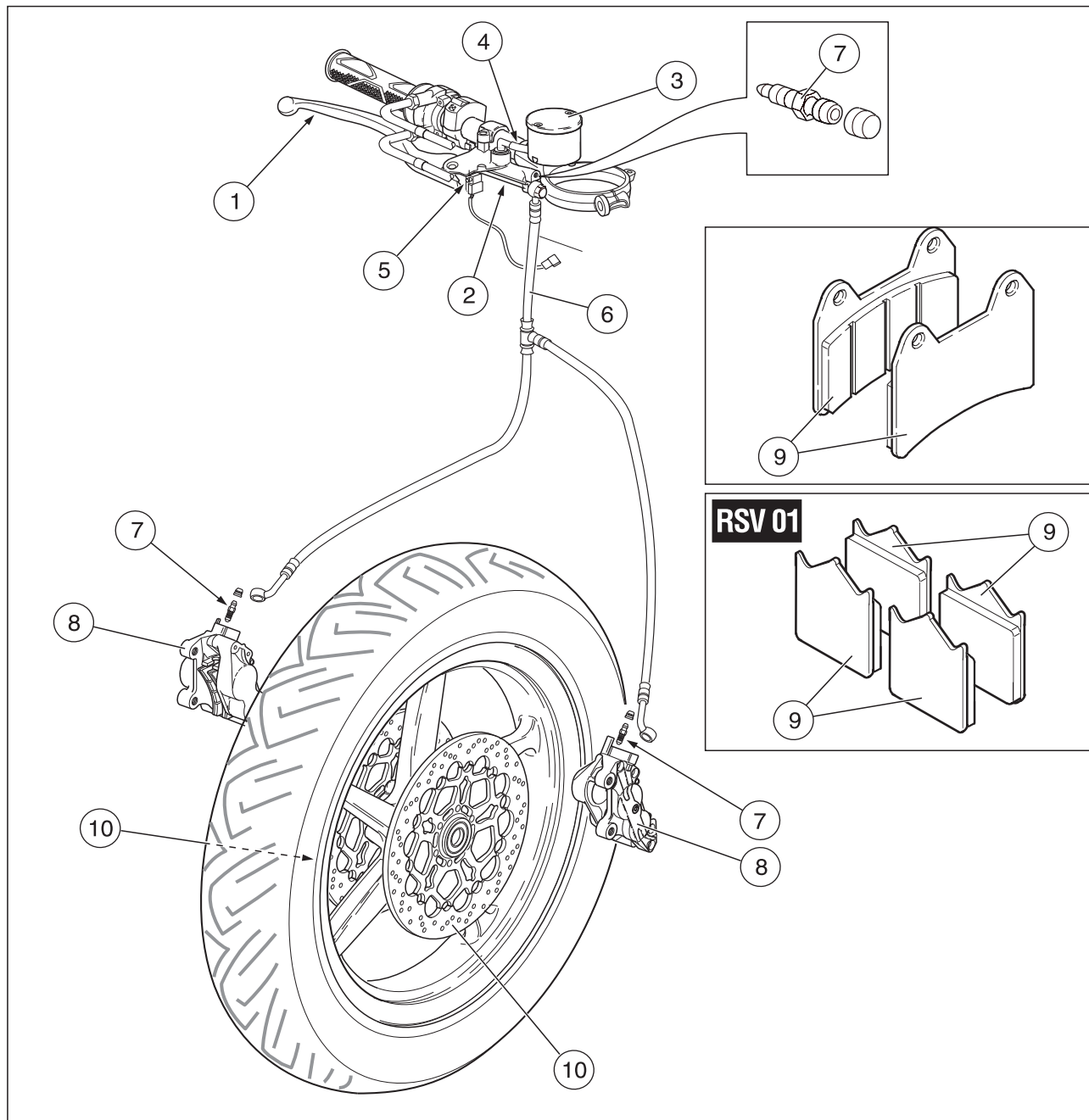

Key

- 1) Brake control lever
- 2) Brakes fluid pump
- 3) Brake fluid tank
- 4) Brakes fluid pipe from tank to pump
- 5) Rear brake light switch
- 6) Brakes fluid pipes from pump to calipers
- 7) Bleeder
- 8) Brake caliper (right and left)
- 9) Brake pads
- 10) Brake disc (right and left)

For further details, see:

- 1.2.4 (BRAKE FLUID);
- 2.17 (CHECKING AND TOPPING UP THE FRONT BRAKE FLUID);
- 2.20 (BLEEDING THE BRAKING SYSTEMS);
- 2.27 (CHECKING THE BRAKE PAD WEAR);
- 8.4.5 (FRONT BRAKING SYSTEM).

⚠ CAUTION

When disassembling/reassembling the brake caliper, replace the caliper fastening screws with two new ones of the same type.

7.5.1 CHANGING THE FRONT BRAKE PADS (models up to 2001)

Carefully read 0.5.1 (PRECAUTIONS AND GENERAL INFORMATIONS) and 2.27 (CHECKING THE BRAKE PAD WEAR).

⚠ WARNING

This vehicle is equipped with a double-disc front braking system (right side and left side). Always change both pads of both front brake calipers.

Replacing the pads of one front caliper only may affect the stability and safety of the vehicle, with serious risks for persons, property and the vehicle itself.

◆ Position the vehicle on the stand.

NOTE The following procedure refers to a single caliper, though it is applicable to both.

- ◆ Using pliers, clamp the head of one pin then the other, turning them just enough so that the two flexible stop pins (1) can be pulled out.
- ◆ Pull out the two flexible stop pins (1).
- ◆ Pull out the two pins (2).
- ◆ Retrieve the spring (3).

NOTE Using pliers, clamp one pad and then the other, shaking them slightly crosswise so as to eliminate any pressure exerted by the caliper pins, making it easier to extract the pads.

◆ Extract the two pads (4).

⚠ CAUTION

Do not pull the brake lever once the pads have been removed as the caliper pins are liable to come out of their slot, resulting in the spillage of brake fluid.

◆ Insert two new pads, positioning them so that the holes are lined up with those in the caliper.

⚠ CAUTION

Always change both pads and make sure that they are correctly positioned inside the caliper.

- ◆ Refit the spring (3) with the arrow inscribed on it pointing up.
- ◆ Insert the two pins (2).
- ◆ Insert the two flexible stop pins (1).
- ◆ Check the front brake fluid level, see 2.17 (CHECKING AND TOPPING UP THE FRONT BRAKE FLUID).

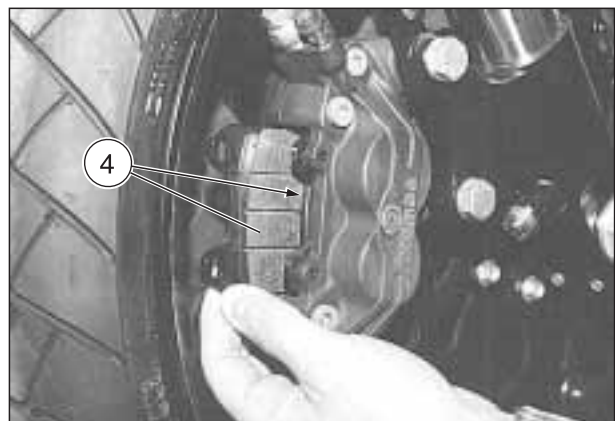
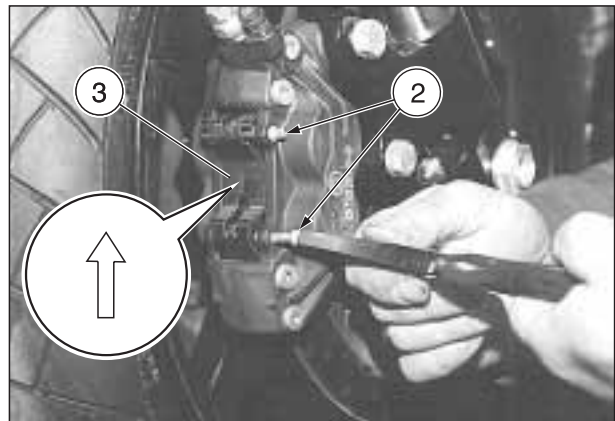
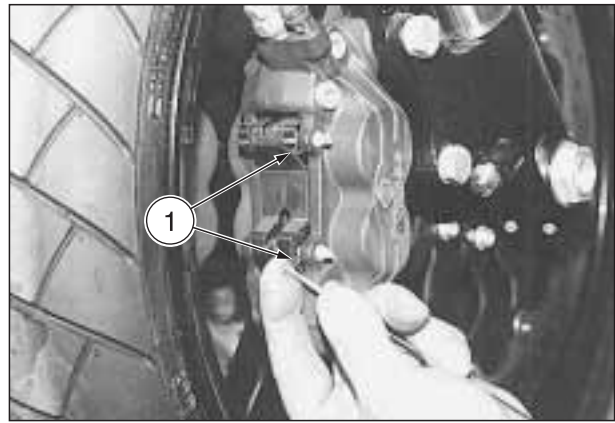

7.5.2 CHANGING THE FRONT BRAKE PADS RSV 01

Carefully read 0.5.1 (PRECAUTIONS AND GENERAL INFORMATIONS) and 2.27 (CHECKING THE BRAKE PAD WEAR).

⚠ WARNING

This vehicle is equipped with a double-disc front braking system (right side and left side).

Always replace all the pads of both the front brake calipers.

Replacing the pads of one front caliper only may affect the stability and safety of the vehicle, with serious risks for persons, property and the vehicle itself.

- ◆ Position the vehicle on the stand.

NOTE The following procedure refers to a single caliper, though it is applicable to both.

- ◆ Press the safety spring (1) and at the same time withdraw the pin (2) from the inside.
- ◆ Remove the safety spring (1).

NOTE Using pliers, clamp one pad and then the other, shaking them slightly crosswise so as to eliminate any pressure exerted by the caliper pins, making it easier to extract the pads.

- ◆ Extract the two pads (3).

⚠ CAUTION

Do not pull the brake lever once the pads have been removed as the caliper pins are liable to come out of their slot, resulting in the spillage of brake fluid.

- ◆ Insert two new pads, positioning them correctly.

⚠ CAUTION

Always change both pads and make sure that they are correctly positioned inside the caliper.

- ◆ Refit the safety spring (1).
- ◆ Press the safety spring (1) and at the same time insert the pin (2) from the inside.
- ◆ Release the safety spring (1).

⚠ WARNING

When released, the safety spring (1) must lock the pin (2) and fit in the appropriate seats (A). If the spring is positioned correctly, it will not be possible to withdraw the pin (2); carry out a check.

- ◆ Check the front brake fluid level, see 2.17 (CHECKING AND TOPPING UP THE FRONT BRAKE FLUID).

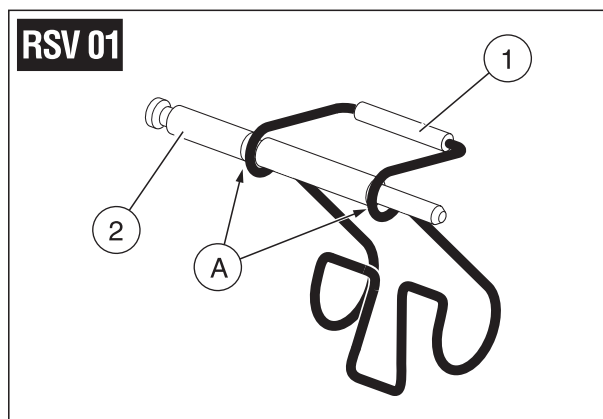
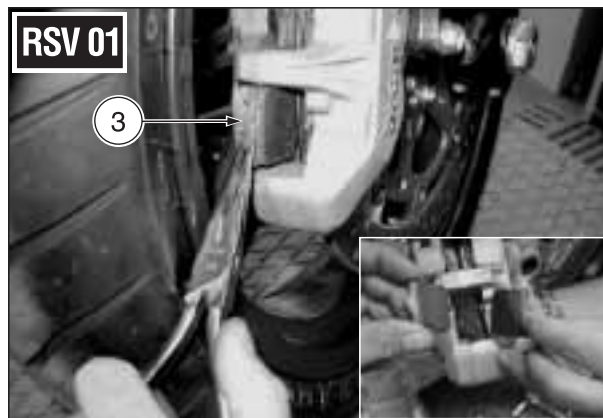
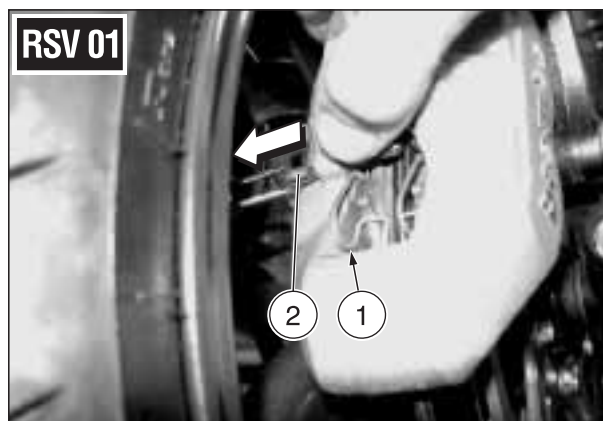
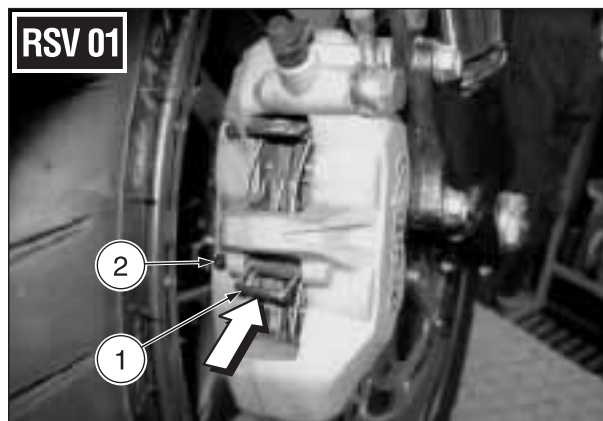

7.5.3 CHECKING THE FRONT BRAKE DISCS

Brake discs:

for the maintenance intervals, see 2.1.1 (REGULAR SERVICE INTERVALS CHART).

NOTE These operations must be performed with the brakes discs installed on the wheel; they refer to a single disc, though they are applicable to both.

- ◆ Check the wear on the disc by measuring the minimum thickness in several places by means of a micrometer. If the minimum thickness is below the minimum value, even in a single point, change the disc.

Brake disc min. thickness: 4.5 mm.

- ◆ Using a comparator, make sure that the maximum wobbling of the disc does not exceed the limit value, otherwise change it, see 7.5.4 (REMOVING THE FRONT BRAKE DISCS).

Brake disc max. wobbling: 0.3 mm.

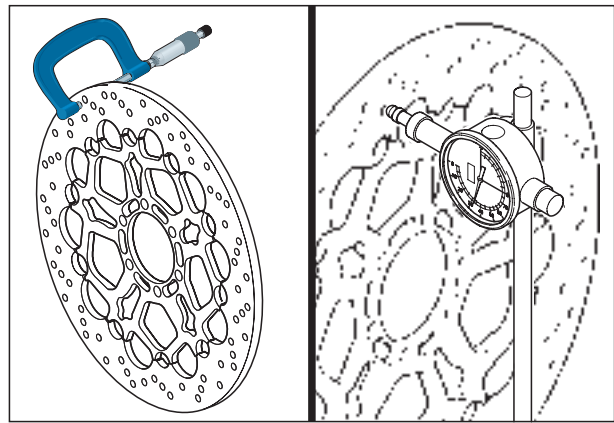

7.5.4 REMOVING THE FRONT BRAKE DISCS

Carefully read 0.5.1 (PRECAUTIONS AND GENERAL INFORMATIONS).

- ◆ Remove the front wheel, see 7.2.1 (REMOVING THE FRONT WHEEL).

NOTE The following procedure refers to a single disc, though it is applicable to both.

To unscrew the screws (1), it is advisable to use a percussion screwdriver, thanks to which it will be possible to detach the screws from the LOCTITE® 243.

- ◆ Unscrew and remove the six brake disc screws (1).

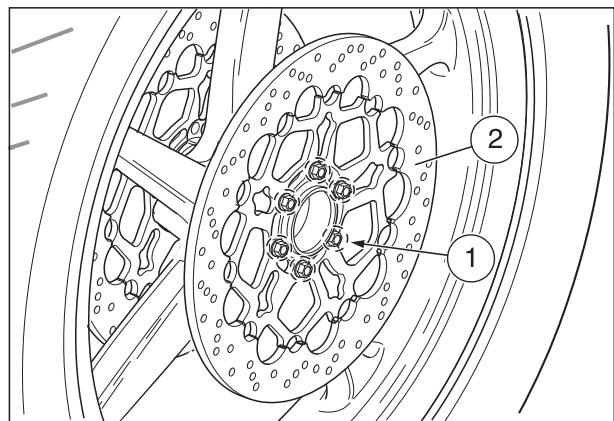

CAUTION

When reassembling, apply LOCTITE® 243 on the thread of the brake disc screws (1).

NOTE When reassembling, screw all the screws (1) on manually and tighten them in a crisscross pattern in the following order: A-B-C-D-E-F.

Brake disc screws (1) driving torque: 30 Nm (3.0 kgm).

- ◆ Remove the brake disc (2).

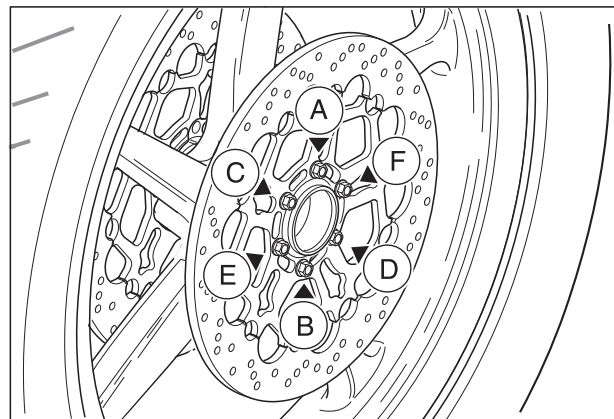

7.5.5 REMOVING THE FRONT BRAKE PUMP

See 7.1.16 (REMOVING THE FRONT BRAKE LEVER).

7.5.6 REMOVING THE FRONT BRAKE CALIPERS

Carefully read 0.5.1 (PRECAUTIONS AND GENERAL INFORMATIONS).

NOTE The following information refers to one brake caliper only, but is valid for both.

⚠ WARNING

A dirty disc soils the pads, with consequent reduction of the braking efficiency. Dirty pads must be replaced, while dirty discs must be cleaned with a high-quality degreaser.

⚠ CAUTION

While disassembling and reassembling the wheel, be careful not to damage the brake pipes, the discs and the pads.

- ◆ Position the vehicle on the side stand.

COMPLETE REMOVAL

- ◆ Drain the front braking system, see 7.5.7 (DRAINING THE BRAKING SYSTEMS).

⚠ CAUTION

Handle brake fluid with care; it may chemically alter painted surfaces and the parts in plastic, rubber, etc. Use latex gloves.

Driving torque of the brake caliper connection screw (1): 20 Nm (2.0 kgm).

- ◆ Unscrew and remove the brake caliper connection screw (1) and take the two sealing washers (2).

⚠ CAUTION

Upon reassembly, replace the two sealing washers with two new washers of the same type.

- ◆ Put a nylon bag on the coupling (3) and fix it to the brake pipe with adhesive tape.
- ◆ Follow the procedure of PARTIAL REMOVAL.

PARTIAL REMOVAL

- ◆ **RSV 01** Set the vehicle on the relevant front support stand, see 1.8.3 (POSITIONING THE VEHICLE ON THE FRONT SUPPORT STAND **OPT**).

⚠ CAUTION

Make sure that the vehicle is stable.

- ◆ **RSV 01** Manually rotate the wheel, so that the space between two spokes of the rim is in correspondence with the brake caliper.
- ◆ **RSV 01** Have someone keep the handlebar steady in running position, so that the steering is locked.

Front brake caliper screws (4) driving torque: 50 Nm (5.0 kgm).

- ◆ Unscrew and remove the two screws (4) that fasten the front brake caliper (5).

Follow ►

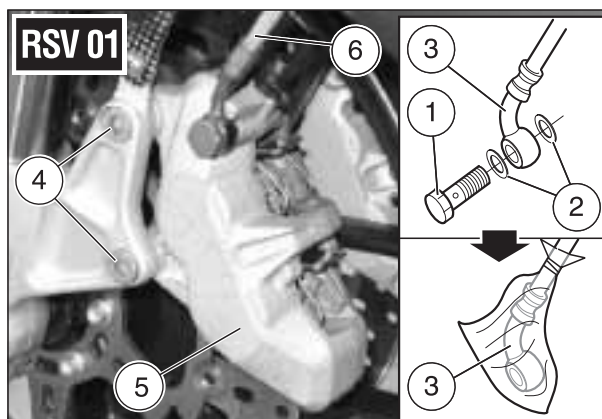
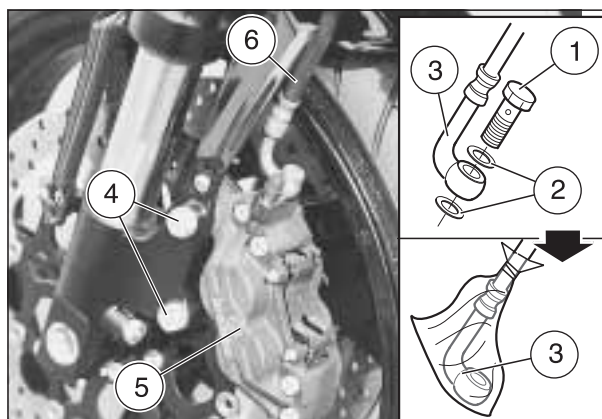
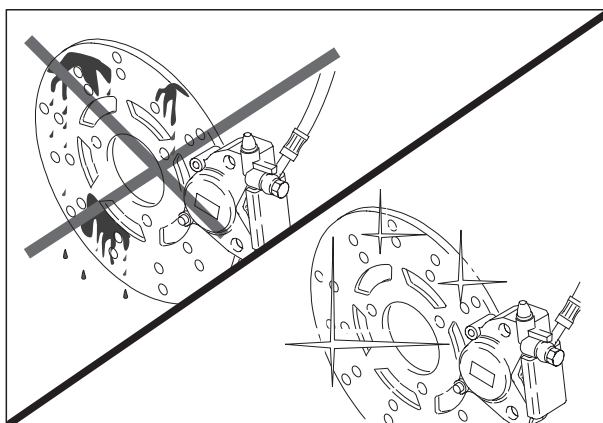

Follow ►

⚠ CAUTION

Proceed with care, in order not to damage the brake pads.

- ◆ Withdraw the brake caliper (5) from the disc, leaving the caliper constrained to the pipe (6) (or releasing it if you are carrying out a COMPLETE REMOVAL).

⚠ CAUTION

Never pull the front brake lever after removing the calipers, otherwise the pistons may go out of their seats, thus causing the outflow of the brake fluid.

REASSEMBLY

⚠ WARNING

Danger of injury. Do not introduce your fingers to align the holes.

⚠ CAUTION

Proceed with care, in order not to damage the brake pads.

- ◆ Insert the brake caliper (5) on the disc and position it so that its fastening holes and the holes on the support are aligned.

⚠ WARNING

Upon reassembly of the brake caliper, replace the caliper fastening screws (4) with two new screws of the same type.

- ◆ Screw and tighten the two screws (4) that fasten the brake caliper.

Front brake caliper screws (4) driving torque: 50 Nm (5.0 kgm).

In case of complete removal:

- ◆ Carry out the COMPLETE REMOVAL operations in the reverse order.

⚠ WARNING

After reassembly, pull the front brake lever repeatedly and check the correct functioning of the braking system.

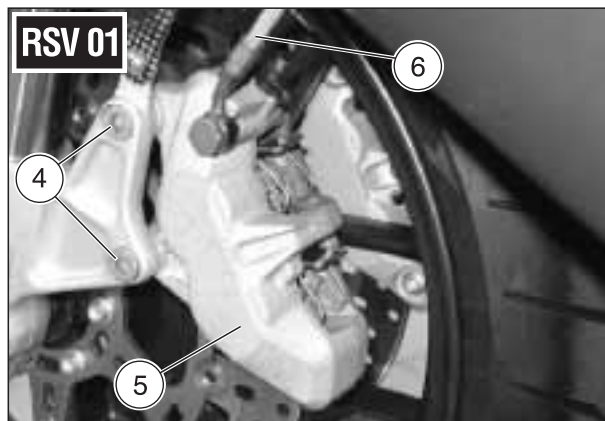
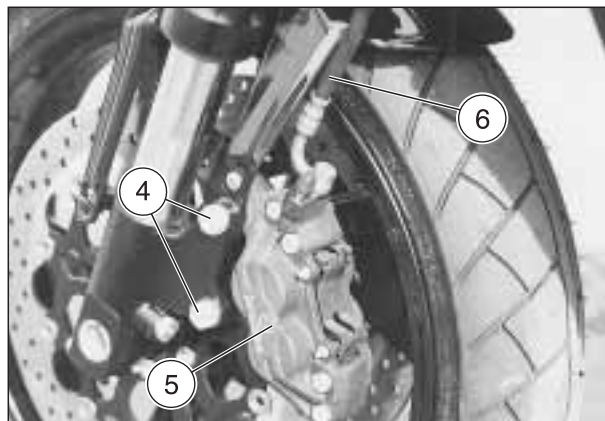

7.5.7 DRAINING THE BRAKING SYSTEMS

Carefully read 0.5.1 (PRECAUTIONS AND GENERAL INFORMATIONS).

⚠ CAUTION

Use latex gloves.

Handle brake fluid with care; it may chemically alter painted surfaces and the parts in plastic, rubber, etc.

DO NOT DISPOSE OF THE FLUID IN THE ENVIRONMENT.

⚠ WARNING

Considering the danger for both rider and vehicle, it is absolutely essential to bleed the hydraulic circuit once the brakes have been refitted and the braking system restored to its normal conditions, see 2.20 (BLEEDING THE BRAKING SYSTEMS).

NOTE This vehicle is provided with disc brakes with two, front and rear braking systems having separate hydraulic circuits.

The front braking system is with double disc (right and left side).

The rear braking system is with single disc (right side).

For the front braking system, the operations described should be carried out on both brake calipers.

- ◆ Position the vehicle on the side stand.
- ◆ Remove the plastic protection cap.
- ◆ Insert a small rubber pipe on the bleeder valve (1).
- ◆ Introduce the free end of the small rubber pipe into a clean container for the collection of the fluid.
- ◆ Loosen the bleeder (1) one turn.
- ◆ Slowly pull the brake lever (for the front brake) or the brake pedal (for the rear brake) thoroughly. Repeat the operation until all the brake fluid has flown into the container.
- ◆ Tighten the bleeder (1).

Bleeder (1) driving torque: 15 Nm (1.5 kgm).

⚠ CAUTION

Clean the small rubber pipe (on its whole length) and the bleeder valve, removing any residue of brake fluid.

- ◆ Remove the small rubber pipe and clean it.
- ◆ Refit the rubber protection cap.
- ◆ Plug the container.

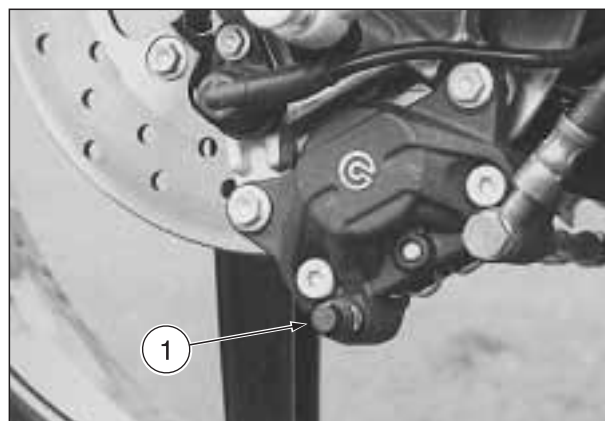
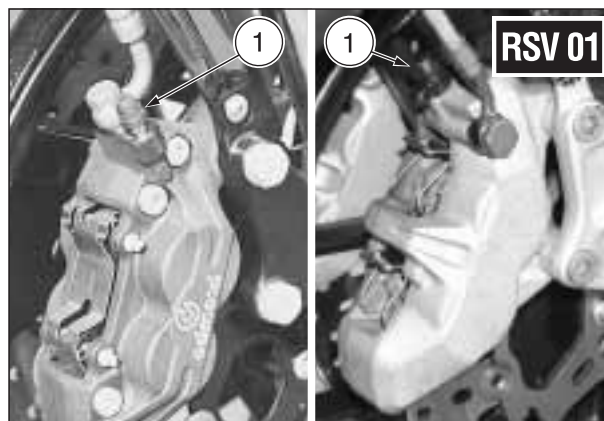

7.6 REAR BRAKE

NOTE This vehicle is provided with disc brakes with two, front and rear braking systems having separate hydraulic circuits.
The rear braking system is with single disc (right side).

⚠ WARNING

Do not use the vehicle if the braking system leaks fluid.

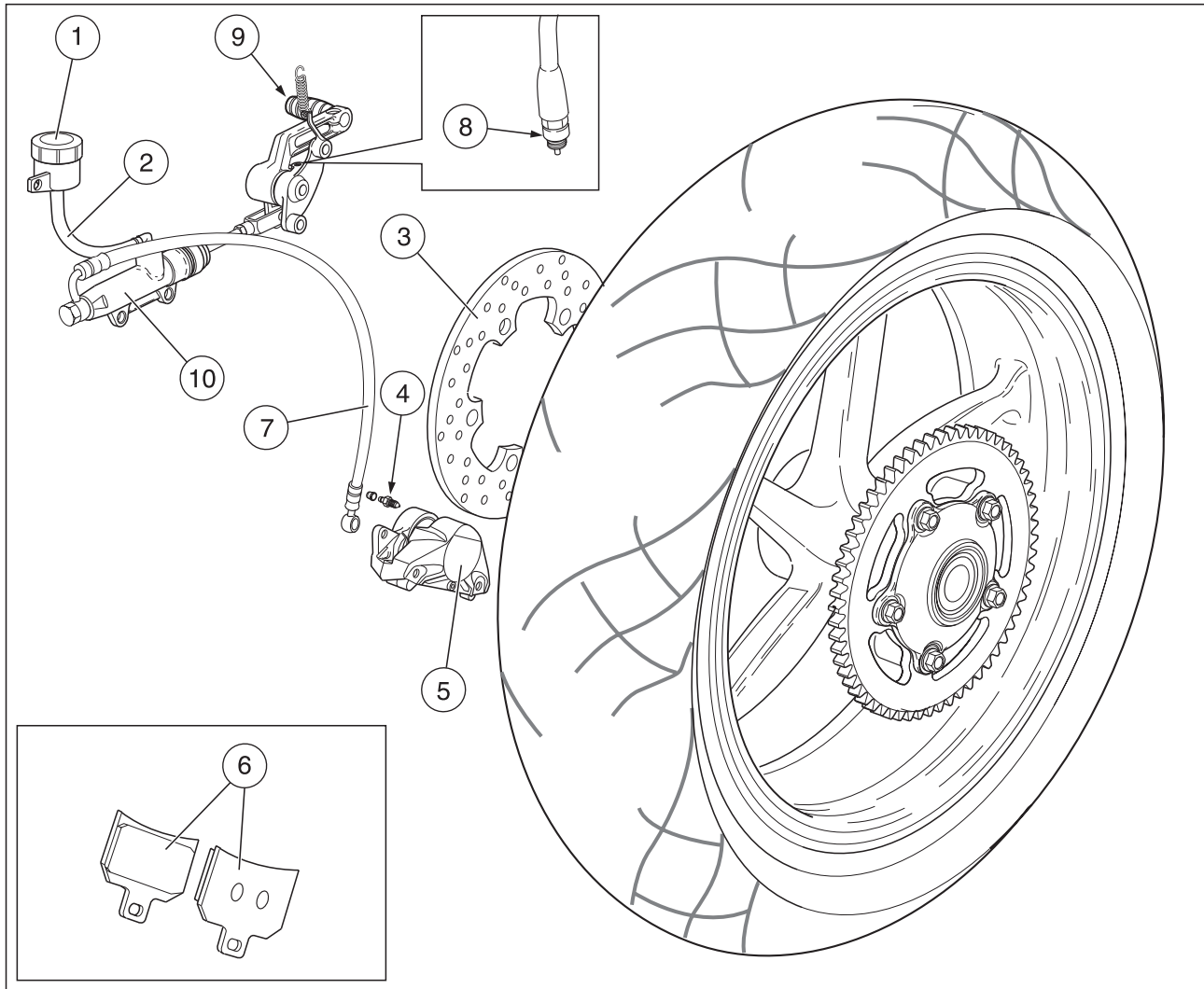

Key

- 1) Brake fluid tank
- 2) Brake fluid pipe from tank to pump
- 3) Brake disc
- 4) Bleeder
- 5) Brake caliper
- 6) Brake pads
- 7) Brake fluid pipe from pump to caliper
- 8) Rear brake light switch
- 9) Brake pedal
- 10) Brake pump

The rear brake reservoir is positioned under the right fairing; to reach it, remove the right fairing, see 7.1.28 (REMOVING THE SIDE FAIRINGS).

For further details, see:

- 1.2.4 (BRAKE FLUID);
- 2.18 (CHECKING AND TOPPING UP THE REAR BRAKE FLUID);
- 2.20 (BLEEDING THE BRAKING SYSTEMS);
- 2.26 (ADJUSTING THE REAR BRAKE CONTROL LEVER CLEARANCE);
- 2.27 (CHECKING THE BRAKE PAD WEAR);
- 8.4.6 (REAR BRAKING SYSTEM).

⚠ CAUTION

When disassembling/reassembling the brake caliper, replace the caliper fastening screws with two new ones of the same type.

7.6.1 CHANGING THE REAR BRAKE PADS

Carefully read 0.5.1 (PRECAUTIONS AND GENERAL INFORMATIONS) and 2.27 (CHECKING THE BRAKE PAD WEAR).

- ◆ Position the vehicle on the stand.
- ◆ Remove the rear brake caliper, see 7.6.5 (REMOVING THE REAR BRAKE CALIPER).

⚠ CAUTION

Do not pull the brake lever once the pads have been removed as the brake caliper pins are liable to come out of their slot, resulting in the spillage of brake fluid.

- ◆ Remove the stop ring (1).

⚠ CAUTION

Before sliding out the pin (2), take note of the positioning of the safety spring (3); when reassembling, it must be refitted in the same way.

- ◆ Pull out the pin (2) and retrieve the safety spring (3).
- ◆ Extract the two pads (4).

⚠ CAUTION

Do not pull the brake lever once the pads have been removed as the caliper pins are liable to come out of their slot, resulting in the spillage of brake fluid.

- ◆ Insert two new pads, positioning them so that the holes are lined up with those in the caliper.

⚠ CAUTION

Always change both pads and make sure that they are correctly positioned inside the caliper.

- ◆ Refit the safety spring (3).
- ◆ Keeping the safety spring (3) pressed in the middle, insert the pin (2) so that it passes over it.
- ◆ Refit the stop ring (1).
- ◆ Check the brake fluid level, see 2.18 (CHECKING AND TOPPING UP THE REAR BRAKE FLUID).

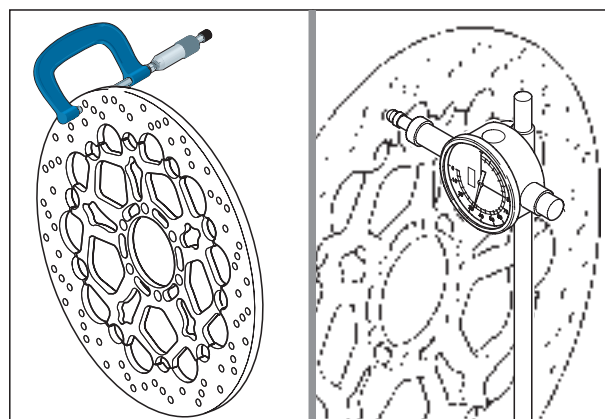
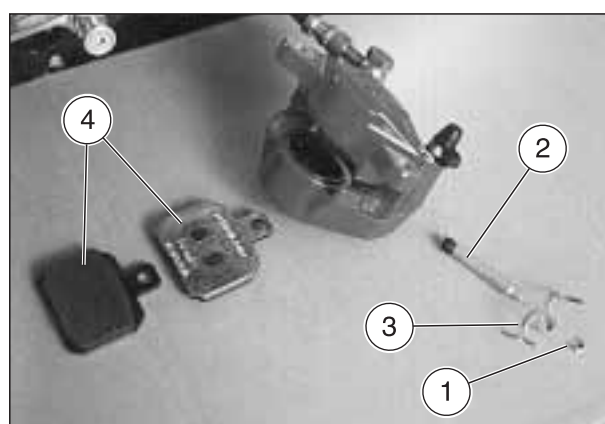
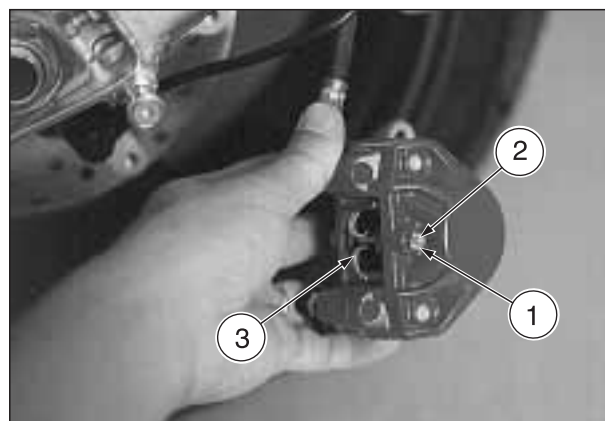

7.6.2 CHECKING THE REAR BRAKE DISC

Brake discs:

for the maintenance intervals, see 2.1.1 (REGULAR SERVICE INTERVALS CHART).

NOTE These operations must be performed with the brake disc installed on the wheel.

- ◆ Check the wear on the disc by measuring the minimum thickness in several places by means of a micrometer. If, even in one point of the disc only, the minimum thickness is below the minimum value, change the disc see 7.6.3 (REMOVING THE REAR BRAKE DISC).

Brake disc min. thickness: 4.5 mm.

- ◆ Using a comparator, make sure that the maximum wobbling of the disc does not exceed the limit value, otherwise change it, see 7.6.3 (REMOVING THE REAR BRAKE DISC).

Brake disc max. wobbling: 0.3 mm.

7.6.3 REMOVING THE REAR BRAKE DISC

Carefully read 0.5.1 (PRECAUTIONS AND GENERAL INFORMATIONS).

- ◆ Remove the rear wheel, see 7.3.1 (REMOVING THE REAR WHEEL).

NOTE To unscrew the screws (1), it is advisable to use a percussion screwdriver, thanks to which it will be possible to detach the screws from the LOCTITE® 243.

- ◆ Unscrew and remove the five brake disc screws (1).

⚠ CAUTION

When reassembling, apply LOCTITE® 243 on the thread of the brake disc screws (1).

NOTE When reassembling, screw all the screws on manually and tighten them in a crisscross pattern in the following order: A-B-C-D-E.

Brake disc screws (1) driving torque: 30 Nm (3.0 kgm).

- ◆ Remove the brake disc (2).

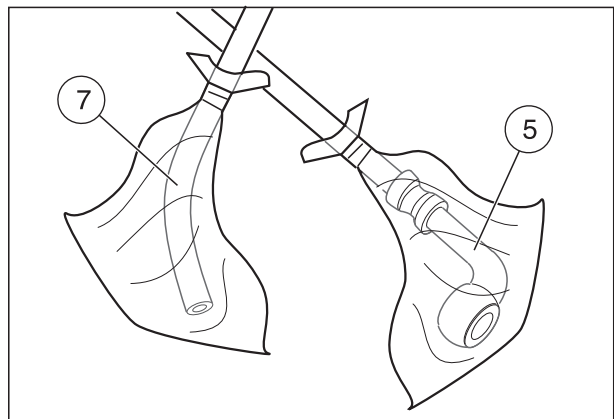
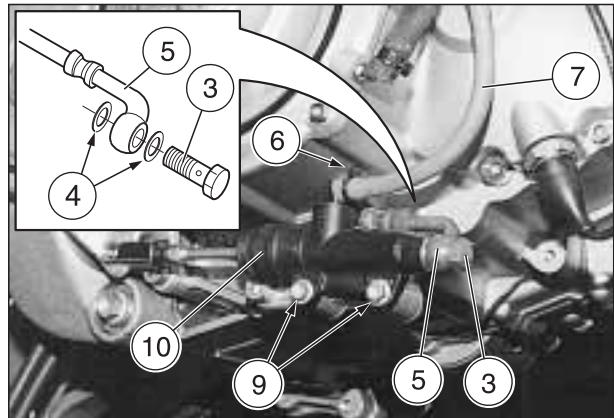
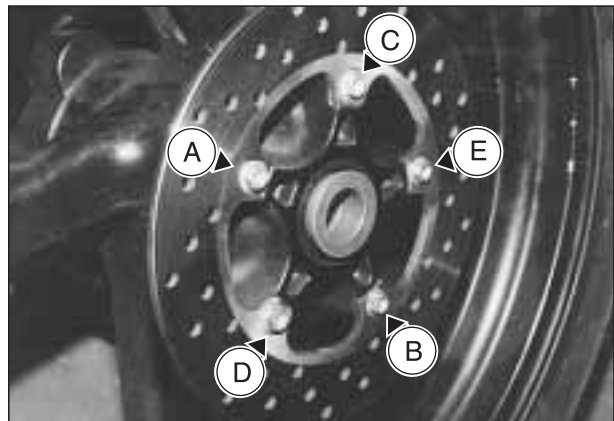
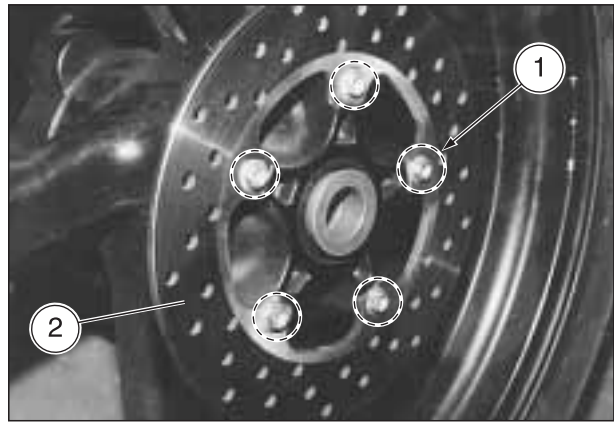

7.6.4 REMOVING THE REAR BRAKE PUMP

- ◆ Remove the lower fairing, see 7.1.34 (REMOVING THE LOWER FAIRING).

For the partial removal, perform ONLY the operations indicated in paragraph "PARTIAL REMOVAL" (excluding the "COMPLETE REMOVAL").

COMPLETE REMOVAL

- ◆ Drain the rear braking system, see 7.5.7 (DRAINING THE BRAKING SYSTEMS).

⚠ CAUTION

Handle brake fluid with care; it may chemically alter painted surfaces and the parts in plastic, rubber, etc. Use latex gloves.

Rear brake pump connection screw (1) driving torque: 20 Nm (2.0 kgm).

- ◆ Unscrew and remove the rear brake pump connection screw (1) and take the two sealing washers (2).

⚠ CAUTION

Upon reassembly, replace the two sealing washers with two new washers of the same type.

- ◆ Put a nylon bag on the coupling (3) and fix it to the brake pipe with adhesive tape.
- ◆ Loosen and move the pipe clamp (4).
- ◆ Slide the pipe (5) from its fitting on the pump.
- ◆ Put a nylon bag on the pipe (5) and fix it to the pipe with adhesive tape.
- ◆ Follow the procedure of PARTIAL REMOVAL.

NOTE When reassembling, top up the brake fluid, see 2.18 (CHECKING AND TOPPING UP THE REAR BRAKE FLUID) and bleed the braking system, see 2.20 (BLEEDING THE BRAKING SYSTEMS).

PARTIAL REMOVAL

Rear brake pump screws driving torque (6): 12 Nm (1.2 kgm).

- ◆ Unscrew and remove the two rear brake pump screws (6).

⚠ CAUTION

Do not force the brake pipes.

- ◆ Remove the pump (7), leaving it constrained to the coupling (3) and to the pipe (5) (or releasing it if you are carrying out a COMPLETE REMOVAL).

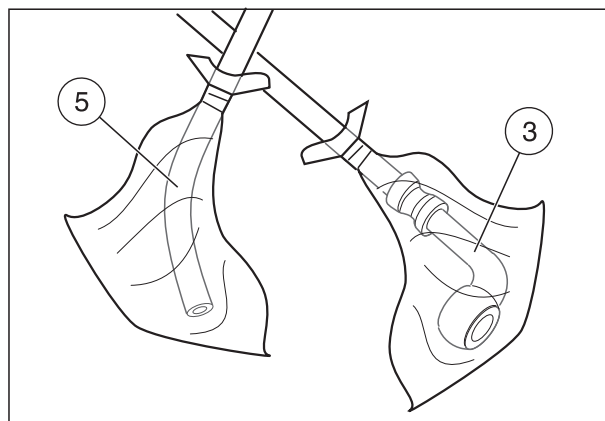
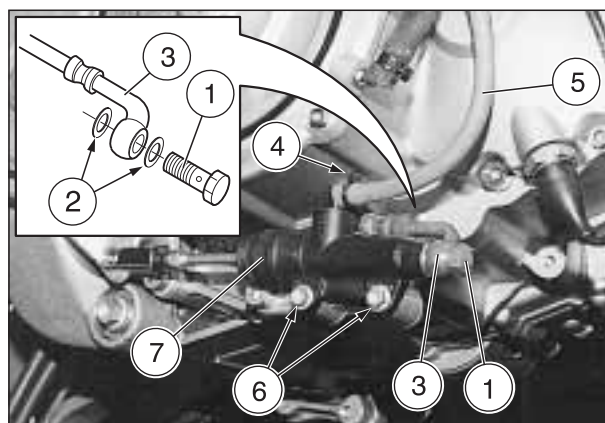

7.6.5 REMOVING THE REAR BRAKE CALIPER

Carefully read 0.5.1 (PRECAUTIONS AND GENERAL INFORMATIONS).

⚠ WARNING

A dirty disc soils the pads, with consequent reduction of the braking efficiency. Dirty pads must be replaced, while dirty discs must be cleaned with a high-quality degreaser.

⚠ CAUTION

Before carrying out the following operations, let the engine and the silencer cool down until they reach room temperature, in order to avoid burns.

While disassembling and reassembling the wheel, be careful not to damage the brake pipe, the disc and the pads.

◆ Position the vehicle on the side stand.

For the partial removal, perform ONLY the operations indicated in paragraph "PARTIAL REMOVAL" (excluding the "COMPLETE REMOVAL").

COMPLETE REMOVAL

◆ Drain the rear braking system, see 7.5.7 (DRAINING THE BRAKING SYSTEMS).

⚠ CAUTION

Handle brake fluid with care; it may chemically alter painted surfaces and the parts in plastic, rubber, etc. Use latex gloves.

Driving torque of the brake caliper connection screw (1): 20 Nm (2.0 kgm).

◆ Unscrew and remove the brake caliper connection screw (1) and take the two sealing washers (2).

⚠ CAUTION

Upon reassembly, replace the two sealing washers with two new washers of the same type.

◆ Put a nylon bag on the coupling (3) and fix it to the brake pipe with adhesive tape.
◆ Follow the procedure of PARTIAL REMOVAL.

Follow ►

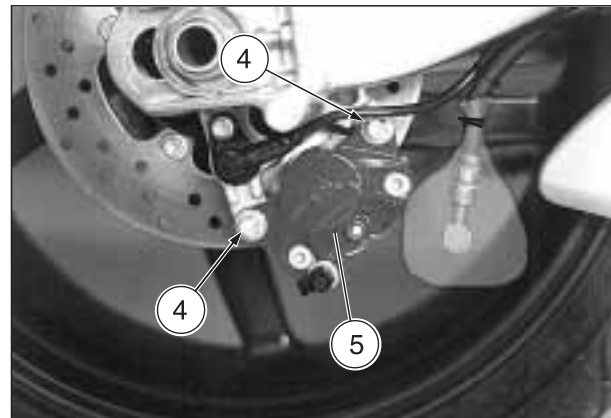
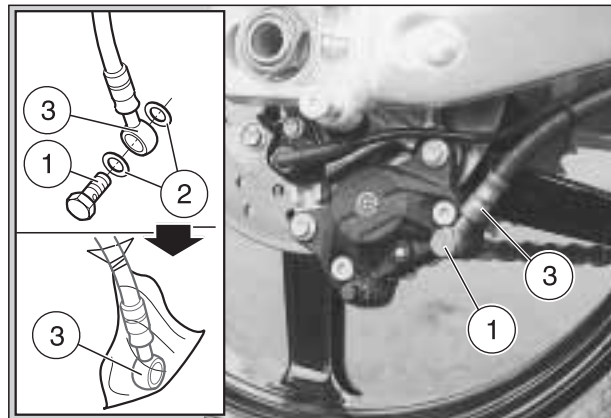
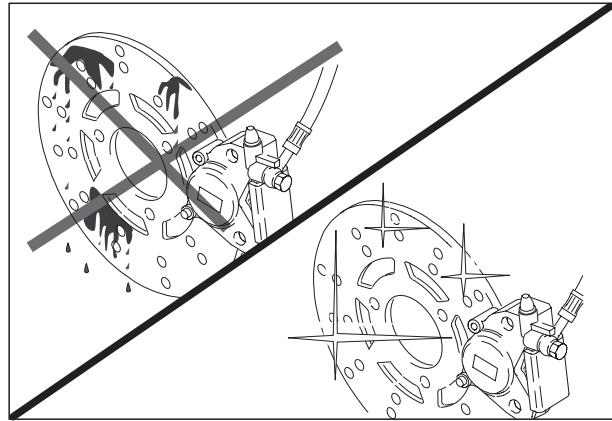

Follow ►

PARTIAL REMOVAL

Rear brake caliper screws (4) driving torque: 25 Nm (2.5 kgm).

- ◆ Unscrew and remove the two brake caliper (5) screws (4).

⚠ CAUTION

Proceed with care, in order not to damage the brake pads.

- ◆ Withdraw the brake caliper (5) from the disc, leaving the caliper constrained to the pipe (6) (or releasing it if you are carrying out a COMPLETE REMOVAL).

⚠ CAUTION

Never pull the rear brake lever after removing the calipers, otherwise the pistons may go out of their seats, thus causing the outflow of the brake fluid.

REASSEMBLY**⚠ WARNING**

Danger of injury. Do not introduce your fingers to align the holes.

⚠ CAUTION

Proceed with care, in order not to damage the brake pads.

- ◆ Insert the brake caliper on the disc and position it so that its fastening holes and the holes on the support are aligned.

⚠ WARNING

Upon reassembly of the brake caliper, replace the screws (4) with two new screws of the same type.

- ◆ Screw and tighten the two screws (4) of the brake caliper (5).

Rear brake caliper screws (4) driving torque: 25 Nm (2.5 kgm).

In case of complete removal:

- ◆ Carry out the COMPLETE REMOVAL operations in the reverse order.

⚠ WARNING

After reassembly, pull the rear brake lever repeatedly and check the correct functioning of the braking system.

7.6.6 DRAINING THE REAR BRAKING SYSTEM

See 7.5.7 (DRAINING THE BRAKING SYSTEMS).

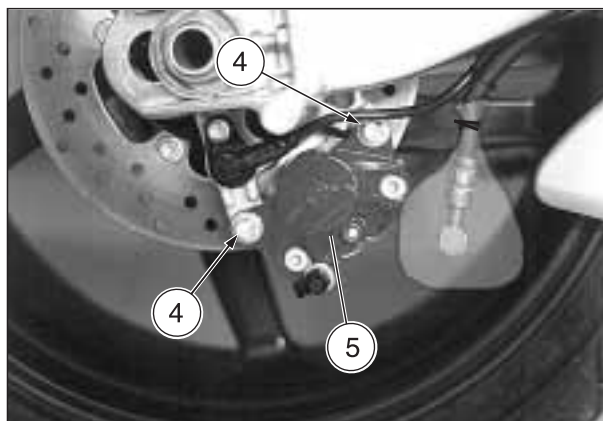

7.7 STEERING

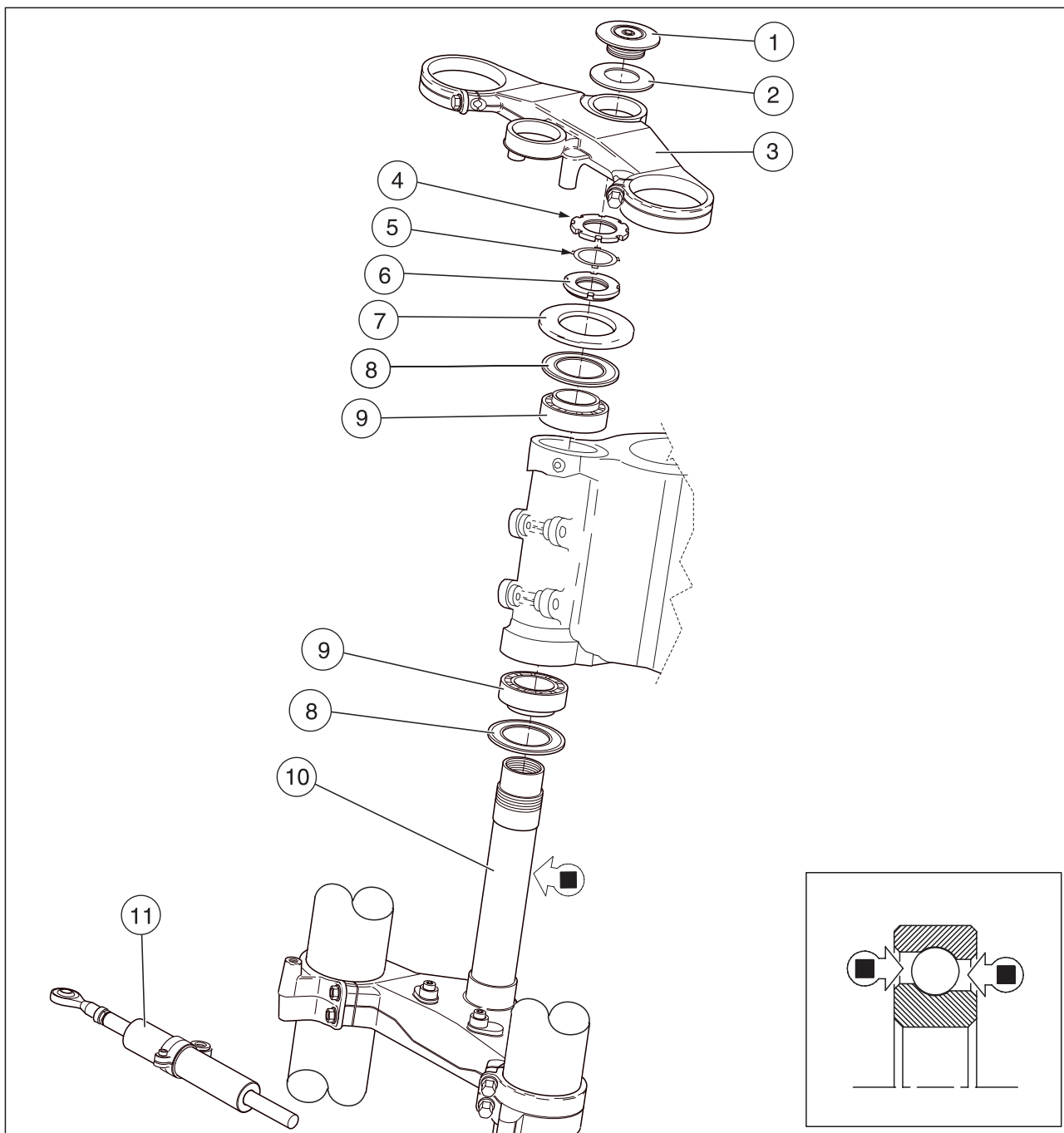

Key

- 1) Upper bush
- 2) Washer
- 3) Upper plate
- 4) Lock ring
- 5) Lock washer
- 6) Adjuster ring
- 7) Protective cover
- 8) Antidust gasket
- 9) Bearings
- 10) Lower plate
- 11) Steering damper

■ = GREASE, see 1.6 (LUBRICANT CHART).

For further details, see:

- 2.28 (STEERING);
- 2.29 (INSPECTING THE FRONT AND REAR SUSPENSION).

7.7.1 REMOVING THE FORK TOGETHER WITH THE FRONT WHEEL

Carefully read 0.5.1 (PRECAUTIONS AND GENERAL INFORMATIONS) and 2.28 (STEERING).

⚠ WARNING

Keep the lifting platform completely lowered, raising it only when indicated.

- ◆ Position the vehicle on the relevant centre stand (1) on a lifting platform, with the front wheel sticking out over the edge of the platform, see 1.8.4 (POSITIONING THE VEHICLE ON THE CENTRE SUPPORT STAND **OPT**)
- ◆ Place a support (3) under the front wheel.
- ◆ Remove the front part of the fairing, see 7.1.22 (REMOVING THE FRONT PART OF THE FAIRING).
- ◆ Remove the front fairing lower lockup, see 7.1.32 (REMOVING THE FRONT FAIRING LOWER LOCKUP).
- ◆ ★ Remove the front brake caliper, see 7.5.6 (REMOVING THE FRONT BRAKE CALIPERS).

⚠ CAUTION

Never pull the front brake lever after removing the calipers, otherwise the pistons may go out of their seats, thus causing the outflow of the brake fluid.

Screw (4) driving torque: 3 Nm (0.3 kgm).

- ◆ Unscrew and remove the screw (4).
- ◆ Recover the bracket (5).

Screw (6) driving torque: 10 Nm (1.0 kgm).

- ◆ Unscrew and remove the screw (6) fastening the steering shock absorber tube (7) and take the bush (8).
- ◆ Remove the fork upper plate, see 7.1.19 (REMOVING THE FORK UPPER PLATE).

NOTE The safety washer (9) is provided with four tabs, two bent upwards and two bent downwards. To release the counter-ring (10) it is necessary to straighten the two tabs that are bent upwards.

- ◆ Use a small flat-tip screwdriver to straighten the tabs (those bent upwards) of the tab washer (9).

NOTE Have the appropriate special tool **OPT** to hand;
– **aprilia** part# 8140203 (complete tool kit for frame including).

- ◆ Use the special setscrew spanner to loosen and remove the lock ring (10).
- ◆ Remove the tab washer (9).

⚠ WARNING

Apply the prescribed driving torque. Exceeding the prescribed driving torque means damaging the steering bearings and the sliding seats, with serious consequences for the functionality of the steering and the safety of the vehicle, people and property.

Adjuster ring (11) driving torque: 40 Nm (4.0 kgm).

- ◆ Use the relevant socket spanner to loosen and remove the adjuster ring (11).

Follow ►

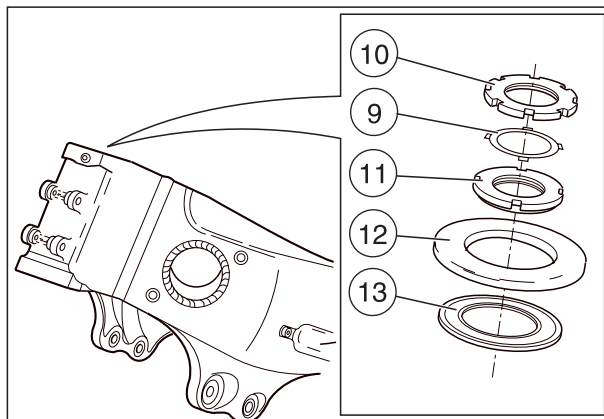
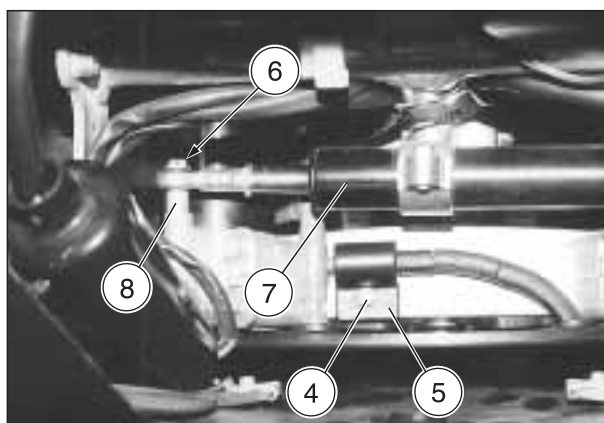
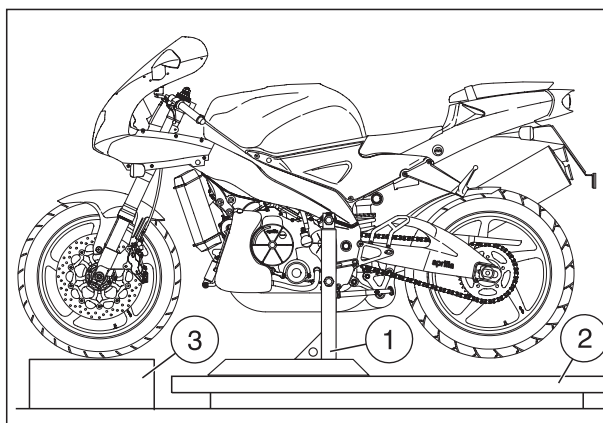

Follow ►

CAUTION

Due to the weight of the forecarriage, the following operations require the assistance of another operator.

Fix the operating procedure before starting work.

The removal must be carried out with the greatest care.

Support the forecarriage to prevent it accidentally dropping.

Whilst removing the forecarriage, take care not to let the brake fluid pipe get entangled.

- ◆ With one operator holding the forecarriage in place, raise the lifting platform (2) slowly until the forecarriage steering head slides off.
- ◆ Remove the front part of the vehicle and store it in a safe place.
- ◆ Lower the lifting platform (2) completely.
- ◆ Recover the protective cover (12).
- ◆ Remove the upper antidust gasket (13).
- ◆ Remove the lower antidust gasket (14).

CAUTION

Wash all the components with a clean detergent.

REASSEMBLY

NOTE When reassembling, the vehicle and the forecarriage must be positioned as for disassembly and the disassembly procedure then followed in reverse order.

- ◆ Smear a film of grease over the entire length of the pin (15), see 1.6 (LUBRICANT CHART).

NOTE Before tightening the adjuster ring (10) completely, turn the steering a number of times both ways so as to enable the bearings to set.

- ◆ Proceed to adjust the bearing slack, see 2.28.2 (ADJUSTING THE BEARING SLACK STEERING).
- ◆ Make sure that turning the handlebars does not result in any of the cables or pipes being pulled too tight, and that none are entangled and/or overlap incorrectly.
- ◆ Top up the brake fluid, see 2.17 (CHECKING AND TOPPING UP THE FRONT BRAKE FLUID).

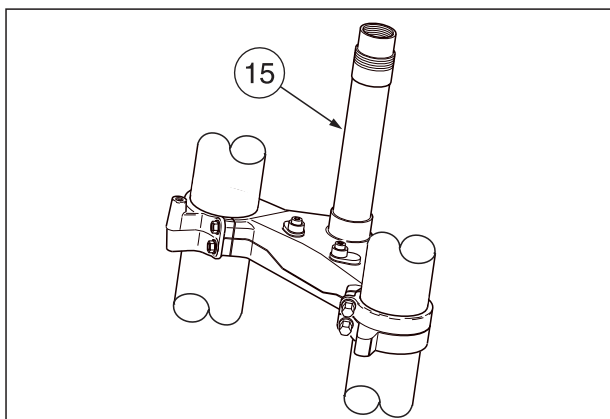
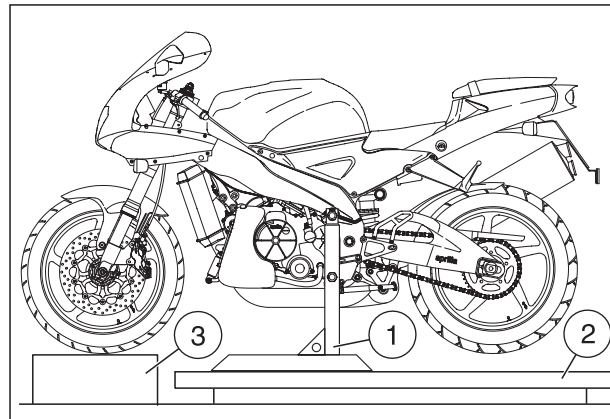
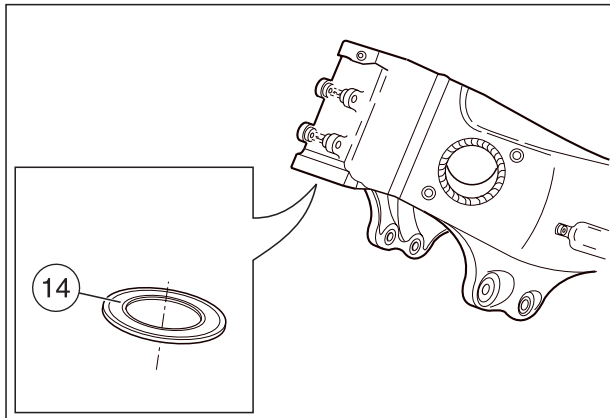
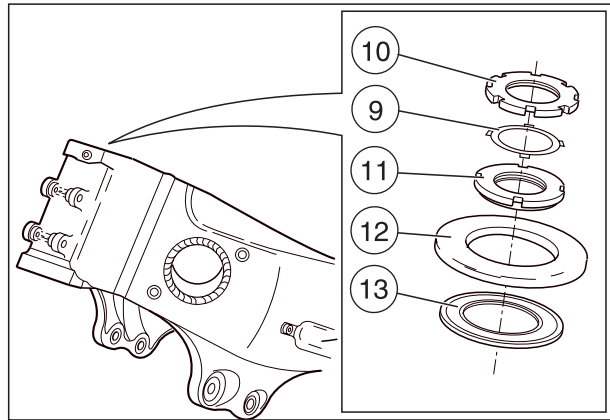

7.7.2 CHECKING THE COMPONENTS

CAUTION

Make sure that all the components are intact, particularly the following.

7.7.3 STEERING BEARINGS

Carry out the check with the bearings mounted on the steering tube.

CHECKING THE ROTATION

- ◆ Manually rotate the inner ring of each single bearing. The rotation must be regular, smooth and noiseless.

If one or both bearings is/are not in compliance with the check parameters:

- ◆ Change both steering tube bearings, see 7.7.5 (REMOVING THE STEERING BEARINGS).

WARNING

Always change both bearings.

Always replace the bearings with bearings of the same type.

CHECKING THE END AND RADIAL PLAY

- ◆ Check the radial play and the end play.

End play: a minimum end play is allowed.

Radial play: none.

If one or both bearings is/are not in compliance with the check parameters:

- ◆ Change both steering tube bearings, see 7.7.5 (REMOVING THE STEERING BEARINGS).

WARNING

Always change both bearings.

Always replace the bearings with bearings of the same type.

7.7.4 STEERING GASKETS

- ◆ Make sure the seals are intact; should they prove damaged or feature signs of excessive wear, change them.

CAUTION

Always change both seals.

Always replace the gaskets with gaskets of the same type.



7.7.5 REMOVING THE STEERING BEARINGS

Carefully read 0.5.1 (PRECAUTIONS AND GENERAL INFORMATIONS).

- ◆ Remove the fork together with the front wheel, see 7.7.1 (REMOVING THE FORK TOGETHER WITH THE FRONT WHEEL).
- ◆ Use a special extractor to extract the upper bearing (1).
- ◆ Use a special extractor to remove the lower bearing (2).

CAUTION

When reassembling, use a drift with the same diameter as the outer race to insert the bearings. Do not strike the balls and/or the inner race. Make sure the bearings are perfectly in contact. Wash all the components with a clean detergent.

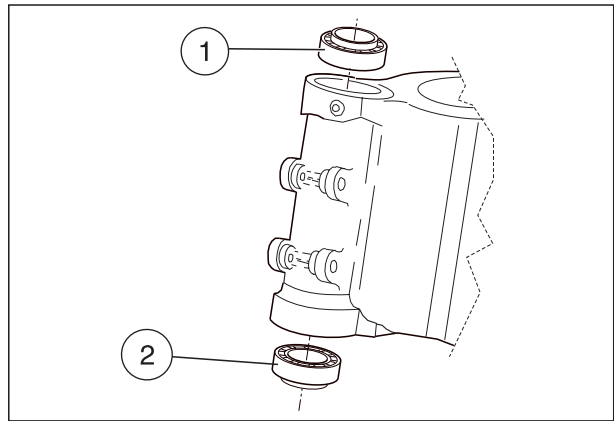

7.7.6 REMOVING THE STEERING SHOCK ABSORBER

Carefully read 0.5.1 (PRECAUTIONS AND GENERAL INFORMATIONS).

- ◆ Remove the front part of the fairing, see 7.1.22 (REMOVING THE FRONT PART OF THE FAIRING).
- ◆ Unscrew and remove the screw (3).

Screw (3) driving torque: 10 Nm (1.0 kgm).

- ◆ Unscrew the retaining screw (4).
- ◆ Unscrew and remove the fastening screw (5) and recover the two bushes (6) as well as the two O-rings (7), if they have slipped off.

Screw (5) driving torque: 10 Nm (1.0 kgm).

- ◆ Remove the steering shock absorber (8).

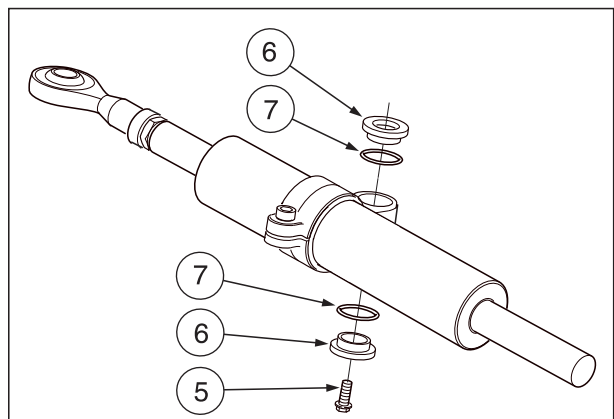
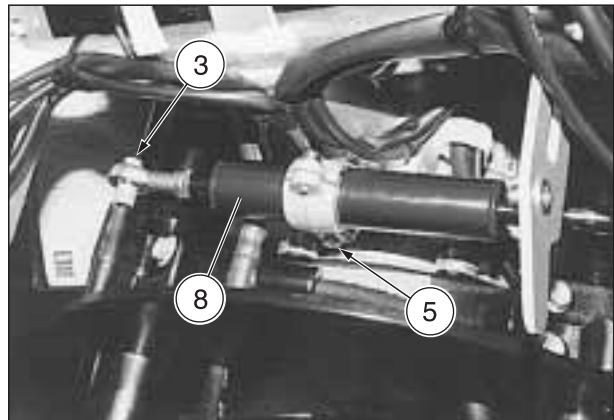

7.8 FRONT FORK

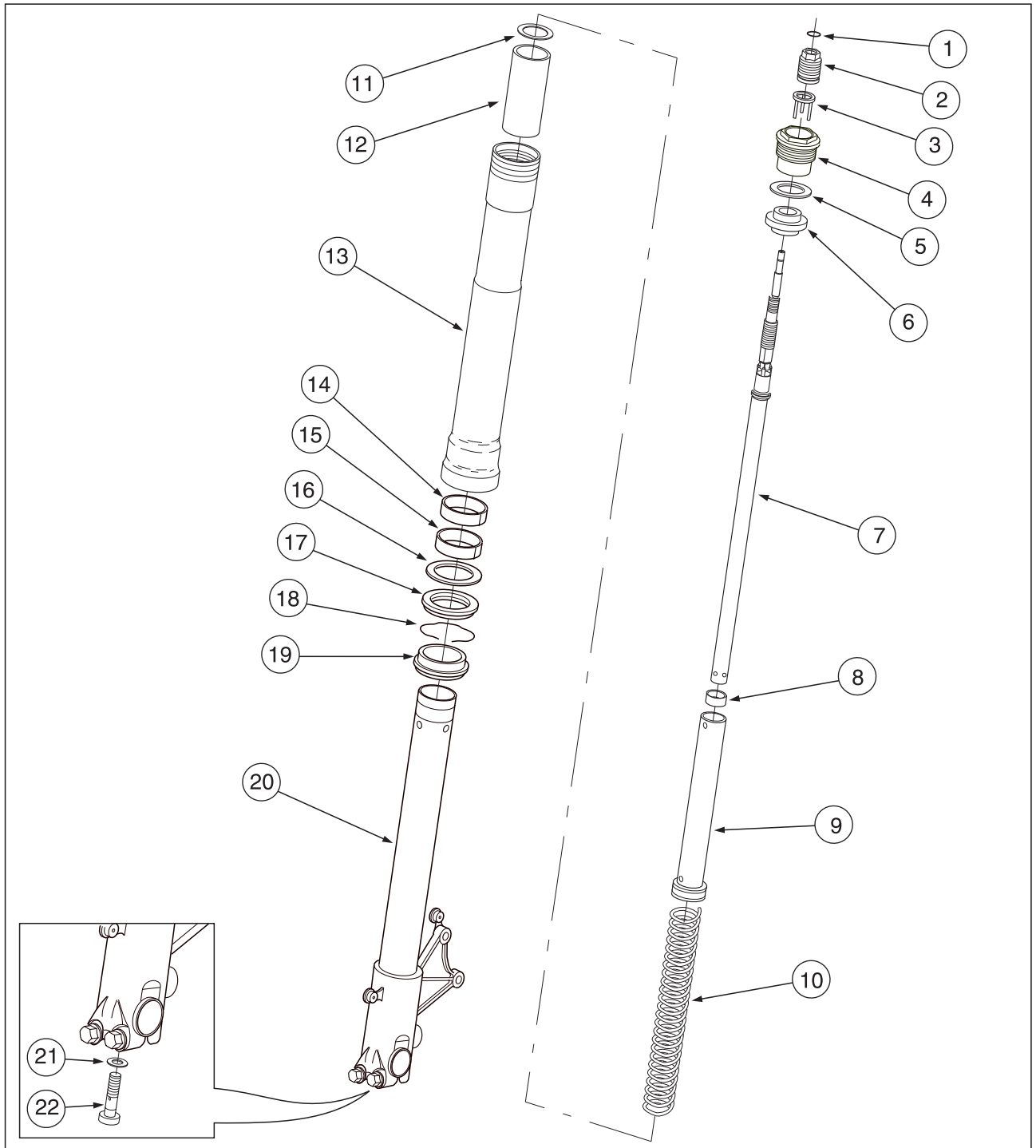

Key

- | | |
|----------------------------|-----------------------|
| 1) Retainer ring | 12) Lower collar |
| 2) Spring preload adjuster | 13) Slider |
| 3) Spring preload pusher | 14) Slide bush |
| 4) Slider upper plug | 15) Guide bush |
| 5) Washer | 16) Stop ring |
| 6) Slide bush | 17) Gasket |
| 7) Piston assembly | 18) Retainer ring |
| 8) Centring bush | 19) Antidust gasket |
| 9) Spring-press tube | 20) Wheel-holder tube |
| 10) Spring | 21) Copper washer |
| 11) Spring rest washer | 22) Centre screw |

7.8.1 CHANGING THE FORK OIL

Carefully read 1.2.3 (FORK OIL) and 2.29.2 (ADJUSTING THE FRONT FORK).

- ◆ Carry out the operations marked with the symbol “*” described at 7.8.3 (DISASSEMBLING THE WHEEL-HOLDER TUBE - SLIDER UNIT).
- ◆ Carry out the operations marked with the symbol “*” described at 7.8.2 (REMOVING THE WHEEL-HOLDER TUBE - SLIDER UNITS).

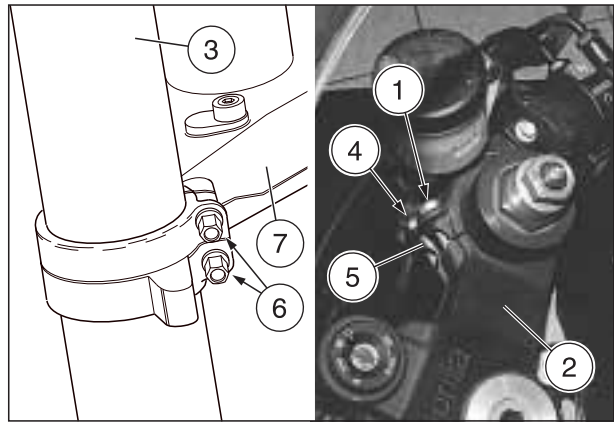

7.8.2 REMOVING THE WHEEL-HOLDER TUBE - SLIDER UNITS

Carefully read 0.5.1 (PRECAUTIONS AND GENERAL INFORMATIONS) and 2.29 (INSPECTING THE FRONT AND REAR SUSPENSION).

NOTE The operations described below are referred to a single wheel-holder tube - slider unit, but are valid for both.

NOTE There are six notches to be found in the upper part of each fork slider, to be used as reference for the six different positions possible (see figure).

- ◆ Check the correspondence of the special notches made on the fork sliders on the fork upper plate and take note of the number of notches in order to be able to reinstall the sliders in the same position (A).

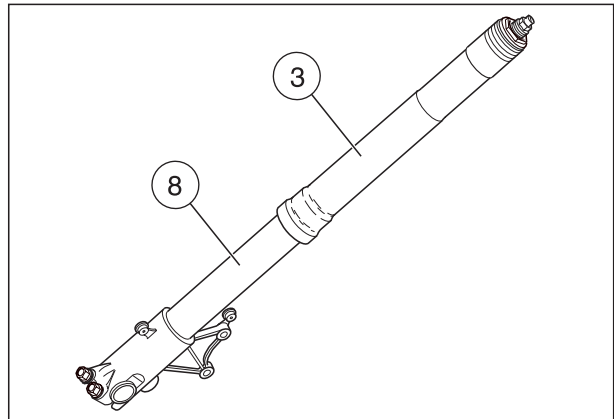

CAUTION

The upper plate must be lined up with the same reference notch on both fork sliders.

- ◆ Remove the front wheel, see 7.2.1 (REMOVING THE FRONT WHEEL).
- ◆ Remove the front mudguard, see 7.1.27 (REMOVING THE FRONT MUDGUARD).
- ◆ Position the vehicle on the special centre stand, see 1.8.4 (POSITIONING THE VEHICLE ON THE CENTRE SUPPORT STAND **OPT**).
- ◆ Remove the front support stand.
- ◆ Loosen the screw (1) locking the upper plate (2) in place on the slider unit (3).
- ◆ Loosen the screw (4) locking the handlebar (5) in place on the slider unit (3).
- ◆ Loosen the two screws (6) locking the lower plate (7) in place on the slider unit (3).
- ◆ Pull the wheel-holder tube (8) complete with slider unit (3) off the upper (2) and lower (7) plates.

NOTE Where necessary, remove the other wheel-holder tube - slider unit.

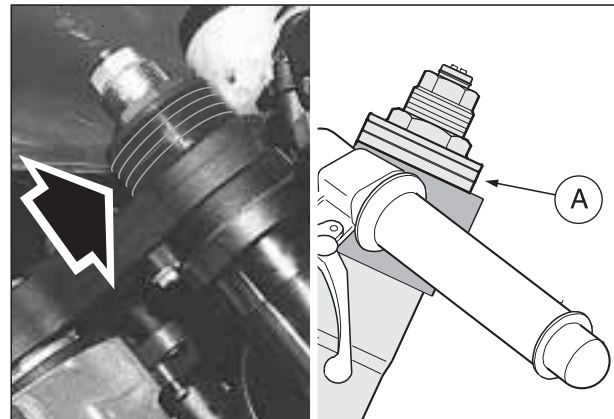

7.8.3 DISASSEMBLING THE WHEEL-HOLDER TUBE - SLIDER UNIT

Carefully read 0.5.1 (PRECAUTIONS AND GENERAL INFORMATIONS), 1.2.3 (FORK OIL) and 2.29 (INSPECTING THE FRONT AND REAR SUSPENSION).

NOTE The right and left wheel-holder tube - slider units have the same inner components.

The operations described below are referred to a single wheel-holder tube - slider unit, but are valid for both.

The operations marked with the symbol “*” are valid also for the fork oil change.

- ◆ * Remove the wheel-holder tube - slider unit, see 7.8.2 (REMOVING THE WHEEL-HOLDER TUBE - SLIDER UNITS).
- ◆ * Carefully clean the whole wheel-holder tube - slider unit.

NOTE Have the appropriate special tools **OPT** to hand:
 – **aprilia** part# 8140151 (complete tool kit for fork including) (A) (B) (C).

- ◆ Prepare a container with capacity exceeding 550 cm³.

⚠ CAUTION

The disassembly must be performed very carefully.

- ◆ * Rotate the upper screw adjuster (1) completely anti-clockwise, in order to reduce the hydraulic braking with extended unit.
- ◆ * Remove the stop ring (2).
- ◆ * Unscrew and remove the adjusting element (3).
- ◆ * Withdraw the spring preload pushing element (4).
- ◆ * Position the wheel-holder tube - slider unit on a vice, interposing the two half-shells of the special tool (C).

⚠ CAUTION

The wheel-holder tube - slider unit is full of oil; do not overturn or incline it excessively during disassembly.

- ◆ * Loosen the slider upper plug (5).
- ◆ * Remove the wheel-holder tube - slider unit from the vice.
- ◆ * Keeping the wheel-holder tube - slider unit in vertical position, unscrew the slider upper plug (5) completely.
- ◆ * Unscrew and remove the threaded pin (A1) from the tool (A).
- ◆ * Position the fixed part of the tool (A) on the spring pressing tube (6), so that the tooth fits in the hole.
- ◆ * Position the threaded pin (A1) in the hole on the fixed part of the tool (A), making sure that when screwed completely it fits in the hole on the spring pressing tube (6).

Follow ►

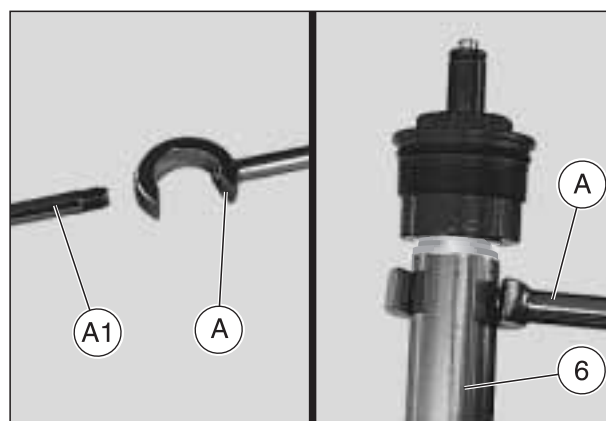
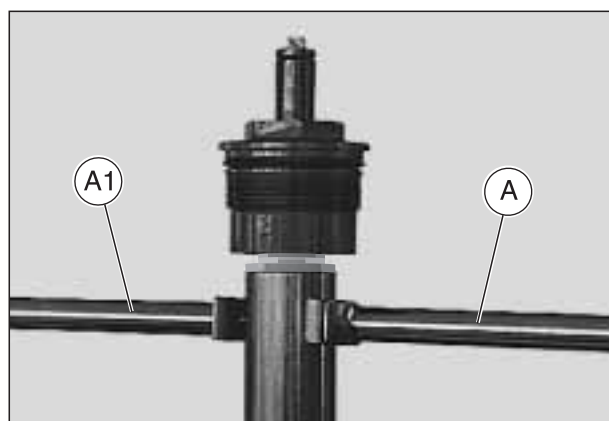
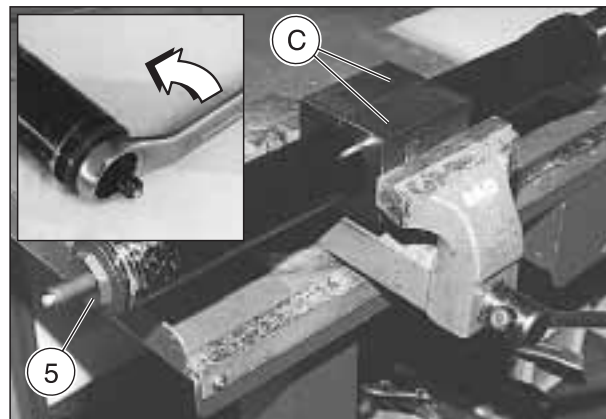
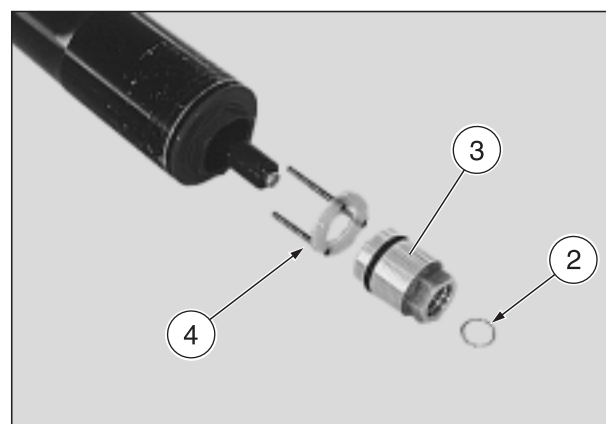
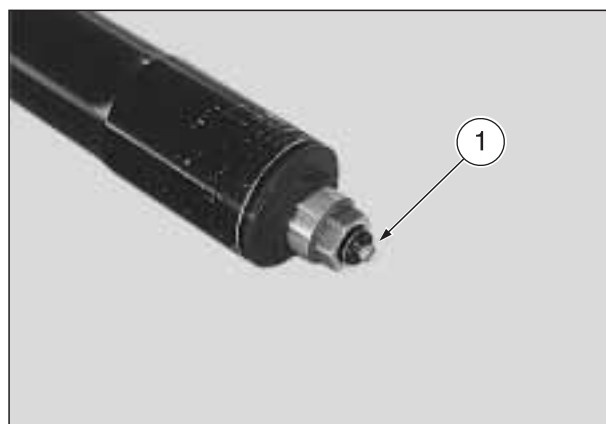

Follow ►

CAUTION

The following operations must be performed by two persons. Fix the operating procedure before starting work.

- ◆ * Rest both hands on the tool (A).
- ◆ * Push downwards and at the same time insert the tool (B) between the locking nut (7) and the washer (8).
- ◆ * Keeping the pumping element (9) still, unscrew the slider upper plug (5) by means of a fork spanner inserted in the appropriate seat.
- ◆ * Rest both hands on the tool (A).
- ◆ * Push downwards and at the same time withdraw the tool (B).
- ◆ * Remove the tool (A).
- ◆ * Remove the washer (8).
- ◆ * Remove the sliding ring (10).

NOTE Before removing them completely, keep the spring pressing tube (6) and the spring (11) out of the fork tube for a few seconds, so that part of the oil drops inside the fork tube itself.

- ◆ * Remove the spring-press tube (6) complete with spring press and slide ring.

Follow ►

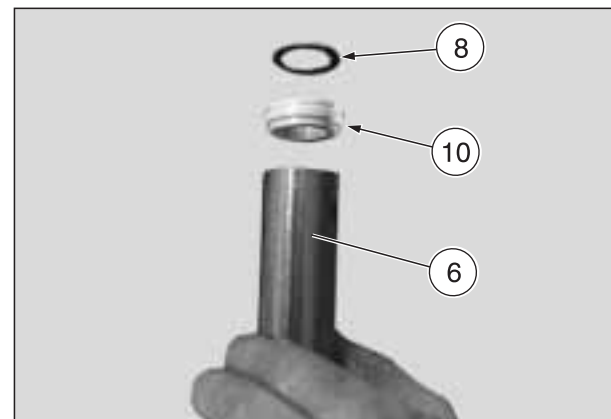
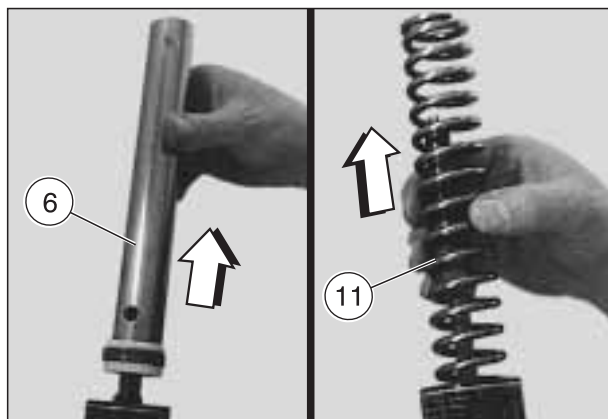
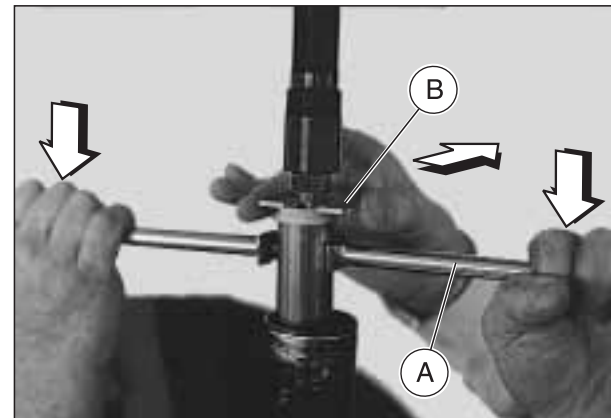
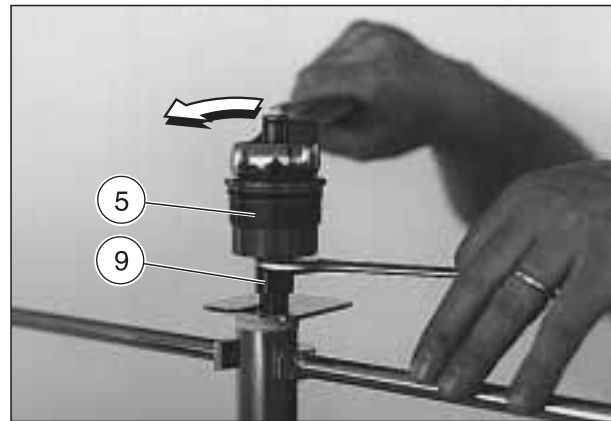
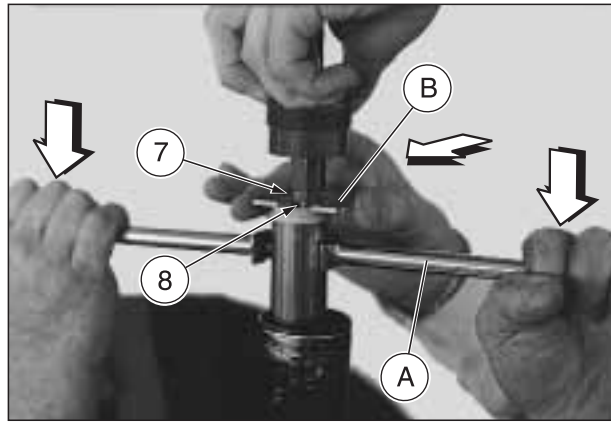

RSV mille

Follow ►

- ◆ * Withdraw and remove the spring (11).
- ◆ * Overturn the wheel-holder tube together with the slider, pouring the oil inside the container (12).

NOTE * In order to have all the oil flow out, slowly and alternately push the pumping element (9) in the slider (eight-ten times).

At the end of this operation, the tube will slide inside the slider freely.

- ◆ If it does not come out during the oil draining process, slide off the following components in the order given:
 - spring rest washer (13);
 - lower collar (14).
- ◆ Remove the antidust gasket (15) from the slider by alternately levering on more points with a cut-tipped screwdriver.

Follow ►

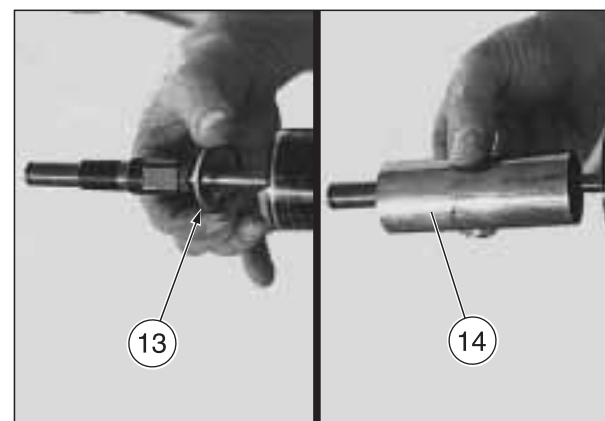
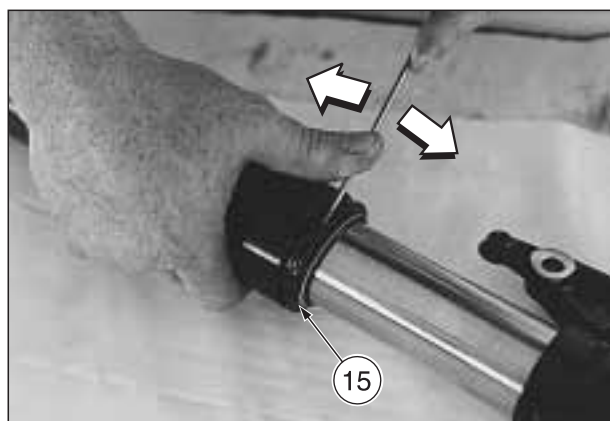
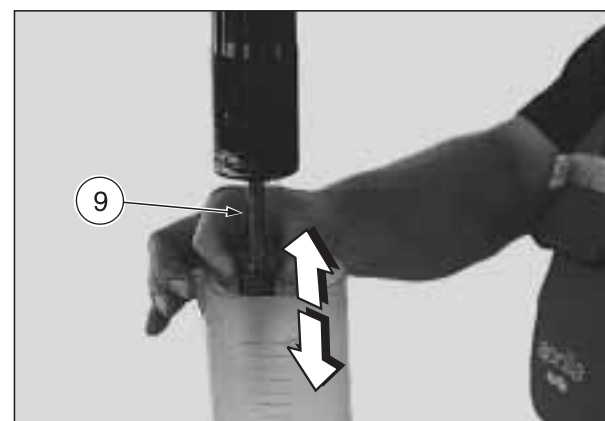
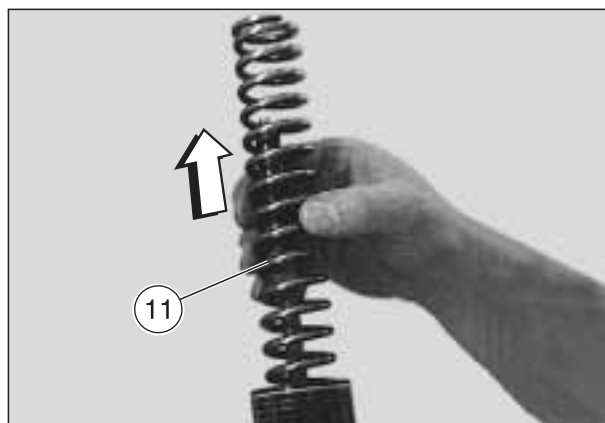

Follow ►

- ◆ Remove the stop ring (16) by means of a cut-tipped screwdriver.

⚠ CAUTION

The following operation must be performed with force, since the slide bushing (17) must push the gasket (18), the ring (19) and the guide bushing (20), which will all resist the withdrawing action.

- ◆ Withdraw the whole wheel-holder tube (21) from the slider (22).

⚠ CAUTION

When withdrawing the slide bushing (17), be careful not to damage it (especially its sliding surface).

- ◆ With a cut-tipped screwdriver, to enlarge moderately and withdraw the slide bushing (17) from the tube (21).
- ◆ Withdraw and remove the following components from the tube (21), in the given order:
 - guide bushing (20);
 - ring (19);
 - gasket (18);
 - stop ring (16);
 - antidust gasket (15).

Follow ►

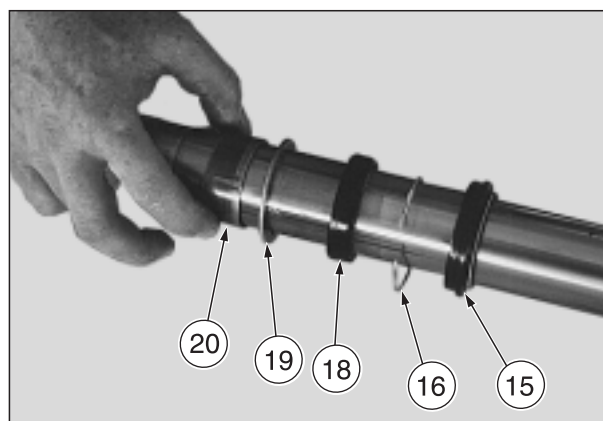
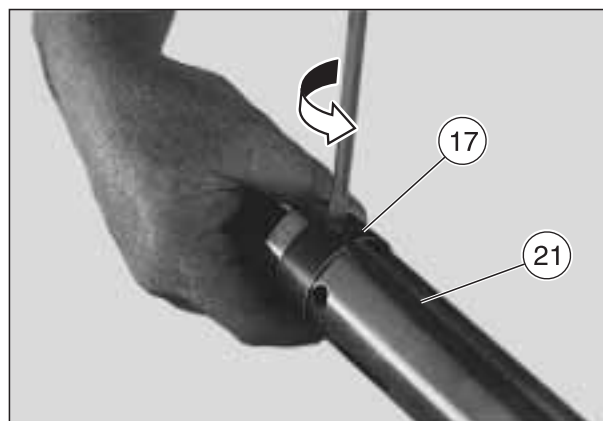
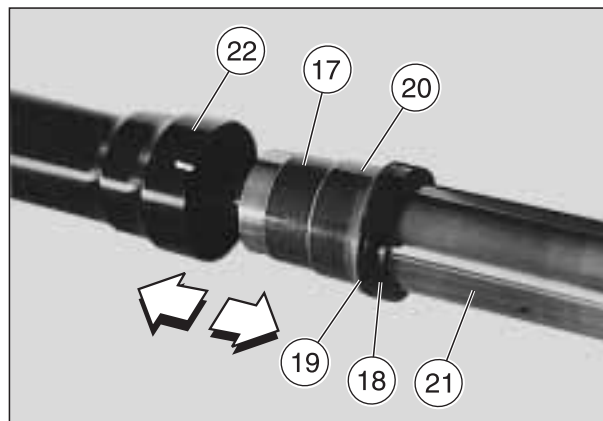
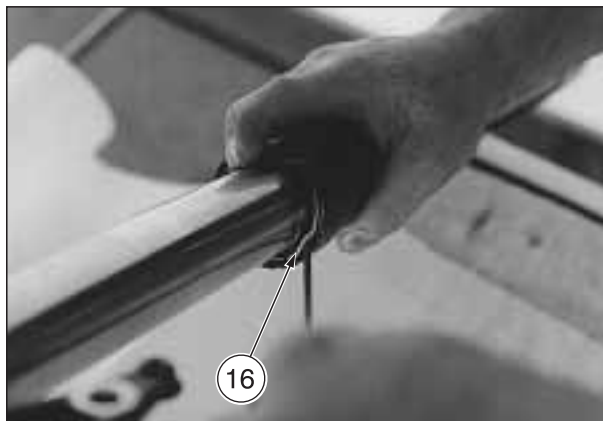

RSV mille

Follow ►

- ◆ Position the wheel-holder tube (21) on a vice, interposing clamps made of soft material (aluminium).
- ◆ Unscrew and remove the centre screw (23) and take the copper washer (24).
- ◆ Withdraw the complete pumping element (9) from the tube (21).

⚠ CAUTION

The pumping element (9) must not be removed.

- ◆ Take the centering bushing (25).

⚠ CAUTION

Wash all the components with a clean detergent.

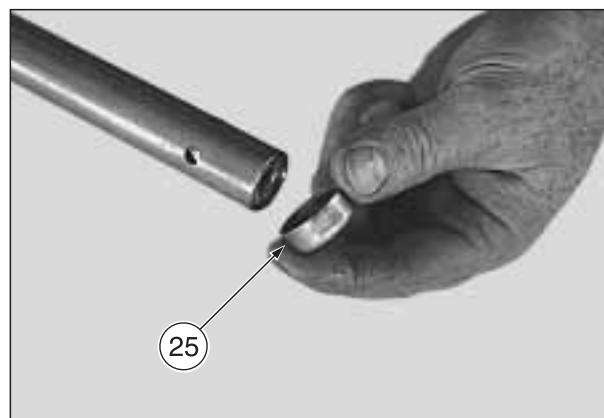
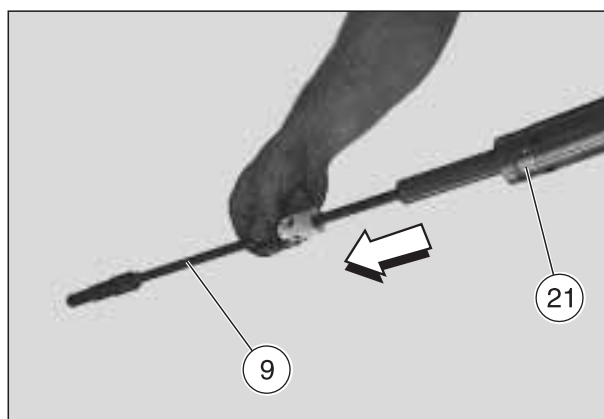
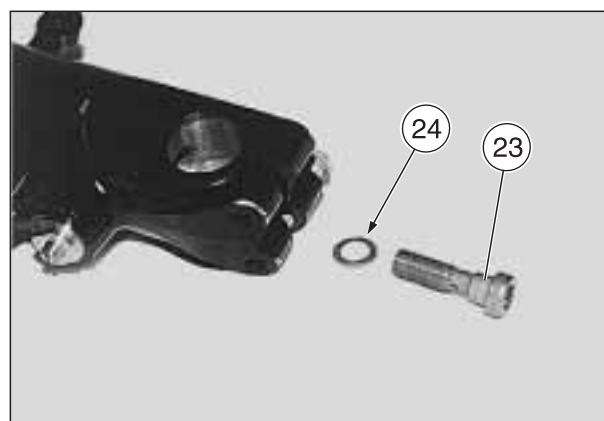
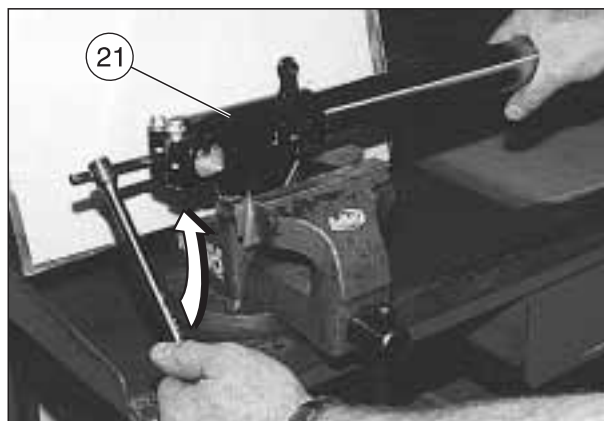

7.8.4 CHECKING THE COMPONENTS

WHEEL-HOLDER TUBE

- ◆ Check the sliding surface, which must be neither lined, nor scratched.
Slight lines can be eliminated by sanding the surface with wet sandpaper (grain 1).
If the lines are deep, change the tube (21).
- ◆ By means of a comparator, make sure that any curving of the tube (21) be lower than the limit value.
If it exceeds the limit value, change the tube.

Curving limit: 0.2 mm.

⚠ WARNING

NEVER straighten a curved tube, since its structure would be weakened, thus making the use of the vehicle quite dangerous.

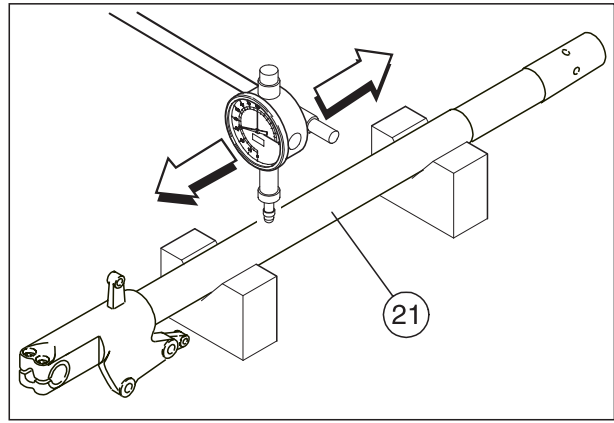

SLIDER

- ◆ Make sure that there are neither damages, nor cracks. Otherwise, change it.

SPRING

- ◆ Check the integrity of the spring (11), making sure that its length does not exceed the limit value.
- ◆ If the length does not correspond to the limit value, change the spring (11).

Minimum length of the spring when not compressed: 284 mm.

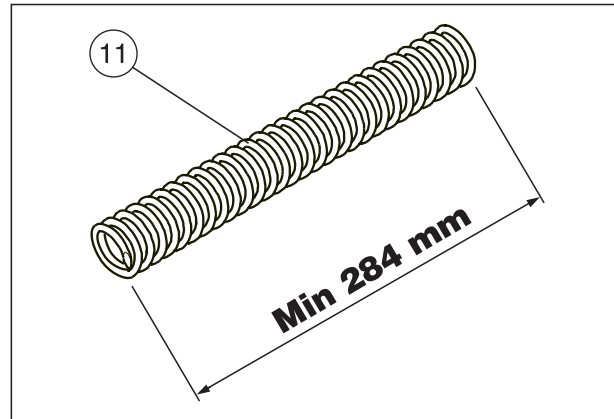

- ◆ Check the condition of the following components:

- slide bushing (17);
- guide bushing (20);
- pumping element (9).

If excessive wear or any damage are observed, change the component in question.

⚠ CAUTION

Remove any accumulation of impurities from the bushings, taking care not to scratch their surfaces.

- ◆ Replace the following components with new ones:

- gasket (18);
- antidust gasket (15);
- the two O rings on the adjusting element (3).

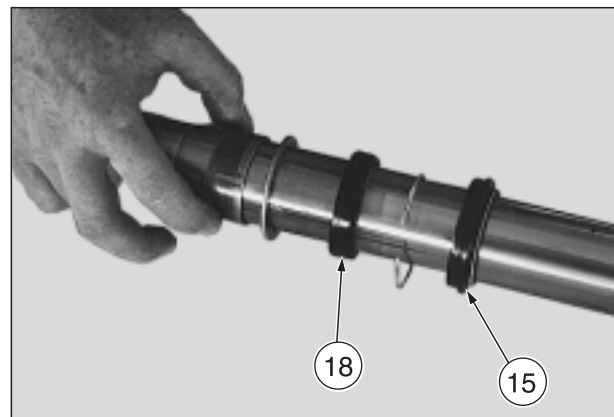
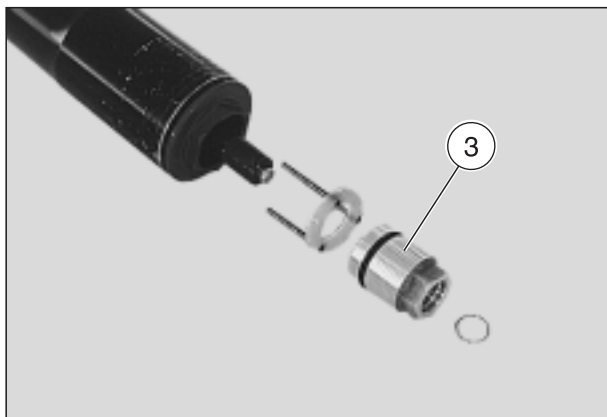
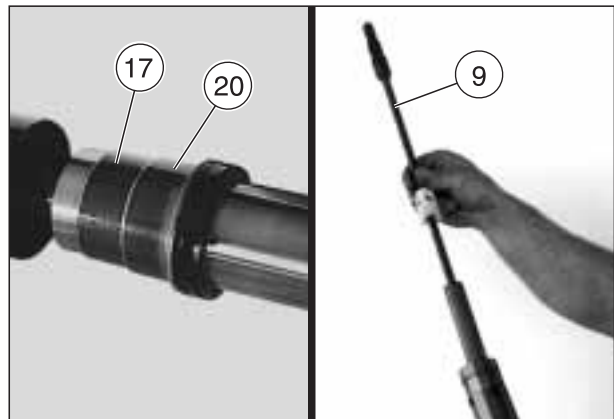

7.8.5 REASSEMBLING THE WHEEL-HOLDER TUBE - SLIDER UNIT

Carefully read 0.5.1 (PRECAUTIONS AND GENERAL INFORMATIONS), 1.2.3 (FORK OIL) and 2.29 (INSPECTING THE FRONT AND REAR SUSPENSION).

NOTE The operations marked with the symbol “*” are valid also for the fork oil change.

⚠ CAUTION

Upon reassembly, proceed with the greatest care and make sure that the sliding surfaces are in perfect conditions (there must not be signs of wear, lines, etc.), otherwise change the component. Be careful to prevent any foreign matter from getting inside.

Do not reuse any oil that has already been drained.

Always replace the gaskets.

The reassembly must be carried out with the greatest care.

NOTE Have the appropriate special tools **OPT** to hand:
– aprilia part# 8140151 (complete tool kit for fork including) (A) (B) (C) (D).

- ◆ Before reinstalling the gaskets and the bushes, spread a film of fork oil on them, see 1.6 (LUBRICANT CHART).
- ◆ Position the wheel-holder tube (21) on a vice with the open part facing upwards, interposing clamps made of soft material (aluminium).

NOTE Apply some grease inside the centering bushing (25), see 1.6 (LUBRICANT CHART).

- ◆ Insert the centering bushing (25) on the bottom of the pumping element (9).
- ◆ Insert the pumping element (9) in the wheel-holder tube (21), making sure that it rests on the base.
- ◆ Position the copper washer (24) on the centre screw (23).
- ◆ Insert and tighten the centre screw (23).

Centre screw (23) driving torque: 35 Nm (3.5 kgm).

- ◆ Remove the wheel-holder tube (21) from the vice.
- ◆ Taking care not to form tape layers, apply some adhesive tape on the end of the wheel-holder tube (21), in such a way as to protect the gaskets during the reassembly.

Follow ►

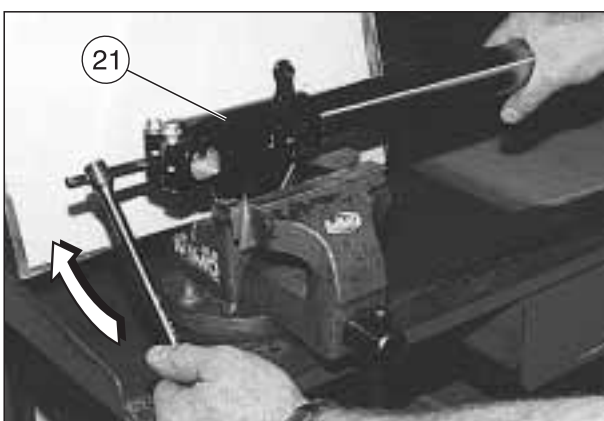
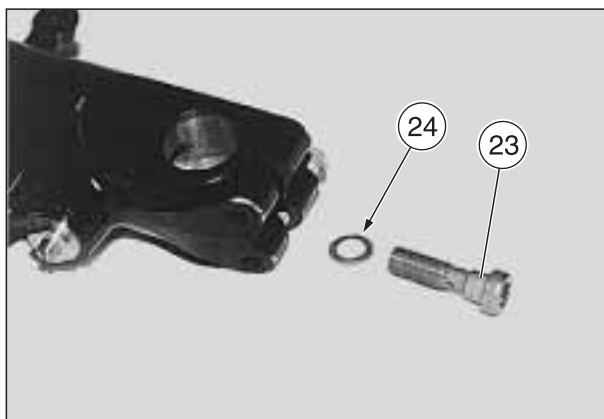
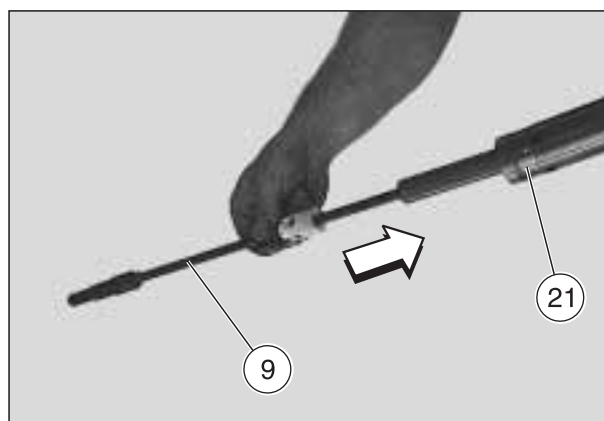
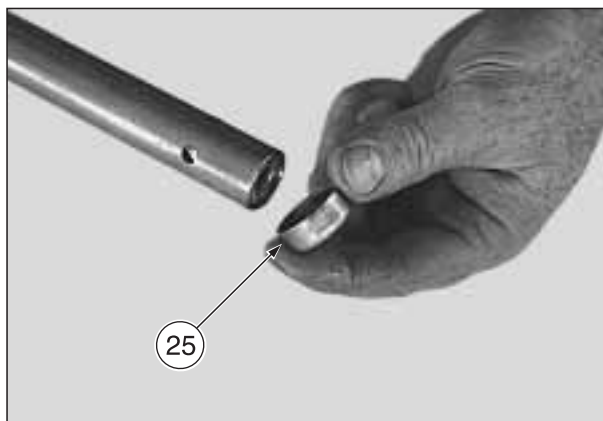

Follow ►

◆ Insert the following components on the wheel-holder tube (21), in the given order:

- antidust gasket (15);
- stop ring (16).

NOTE Introduce the gasket (18), positioning the side with the writings towards the stop ring (16).

- gasket (18);
- ring (19);
- guide bushing (20).

◆ Move the five components mentioned above completely towards the wheel-holder.

◆ Remove the adhesive tape from the end of the wheel-holder tube (21).

◆ Lock the guide bushing (20) in its position by means of some adhesive tape.

◆ Put back the slide bushing (17) on the wheel-holder tube (21).

Follow ►

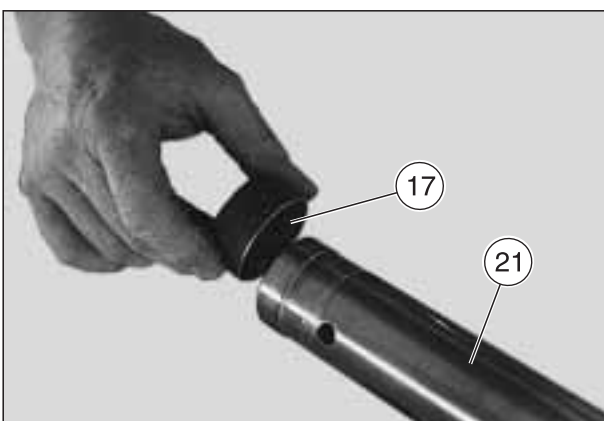
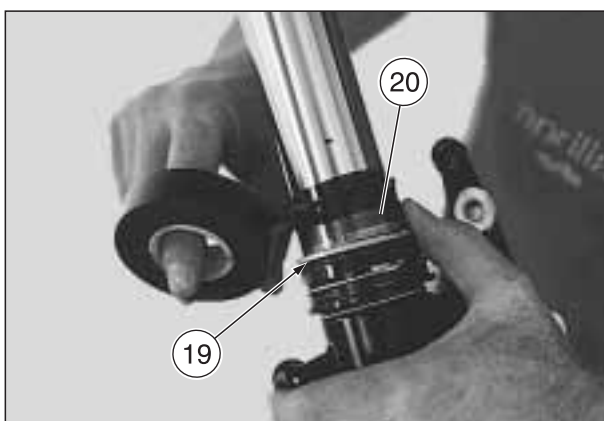
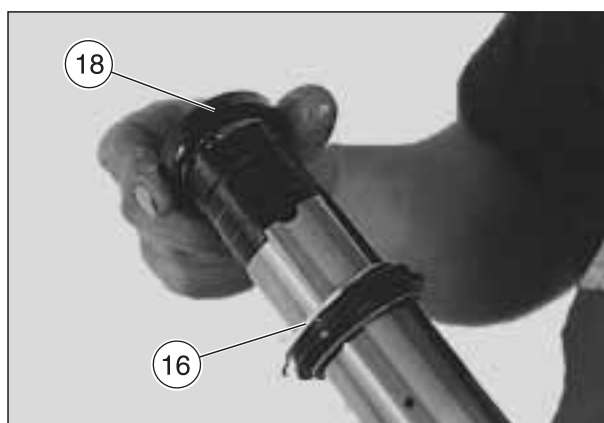
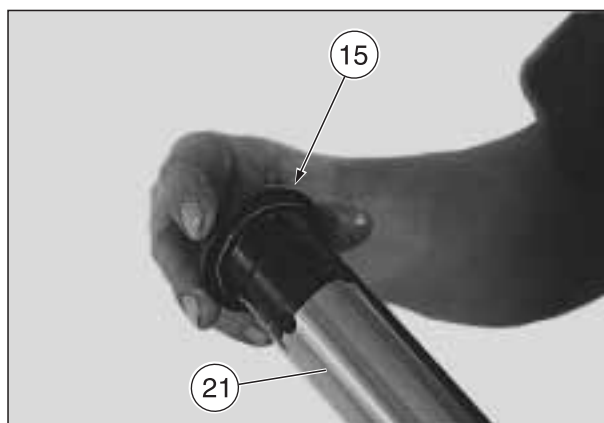

Follow ►

- ◆ Insert the tube (21) in the slider (22).
- ◆ Remove the adhesive tape.
- ◆ Position the two half-shells of the tool (D) on the wheel-holder tube (21), before the guide bushing (20).
- ◆ Grasping the tool (D), push the guide bushing (20) in the correct position in its seat on the slider (22).
- ◆ Remove the tool (D).
- ◆ Insert the ring (19), making sure that it is in the correct position.
- ◆ Position the two half-shells of the tool (D) on the wheel-holder tube (21), before the gasket (18).
- ◆ Grasping the tool (D), push the gasket (18) in its seat on the slider (22) with force, making sure that it is in the correct position.
- ◆ Remove the tool (D).
- ◆ Insert the stop ring (16) in the appropriate seat on the slider (22).
- ◆ Position the two half-shells of the tool (D) on the wheel-holder tube (21), before the antidust gasket (15).
- ◆ Grasping the tool (D), push the antidust gasket (15) in the appropriate seat on the slider (22) and make sure that it is correctly positioned.
- ◆ * Grasp the tube (21) and move it slowly and alternately more than once.

⚠ CAUTION

The tube (21) must slide inside the slider (22) smoothly, without finding any obstacle; if this does not happen, it means that the guide bushing (20), the slide bushing (17) or the gasket (18) are damaged.

- ◆ * Keep the slider (22) in vertical position.
- ◆ * Push the slider (22) to the end of its stroke.
- ◆ * Pour fork oil inside the tube, see 1.6 (LUBRICANT CHART) until reaching the correct level, which can be measured by introducing a graduated stick (26) in the tube.

Oil quantity: $520 \pm 2.5 \text{ cm}^3$.

Oil level: $118 \pm 2 \text{ mm}$ (from the slider edge).

NOTE In order to obtain a correct measurement of the oil level, the slider (22) must be perfectly vertical. The oil level must be the same for both tubes.

Follow ►

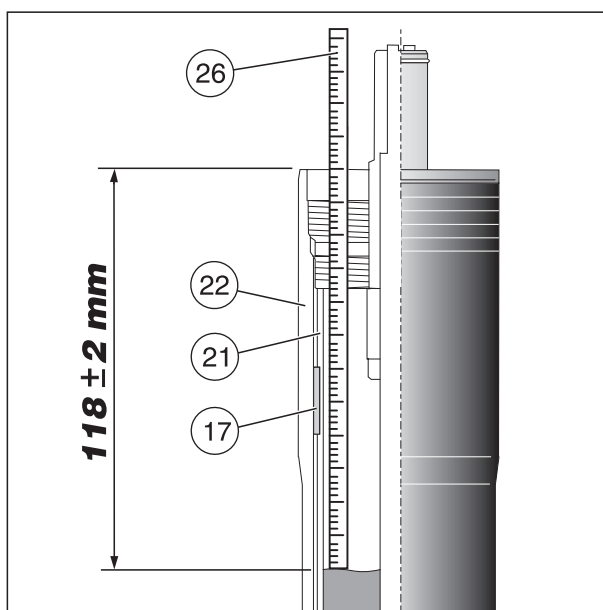
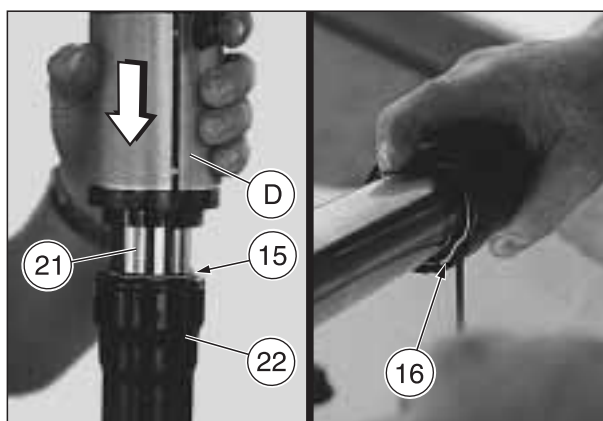
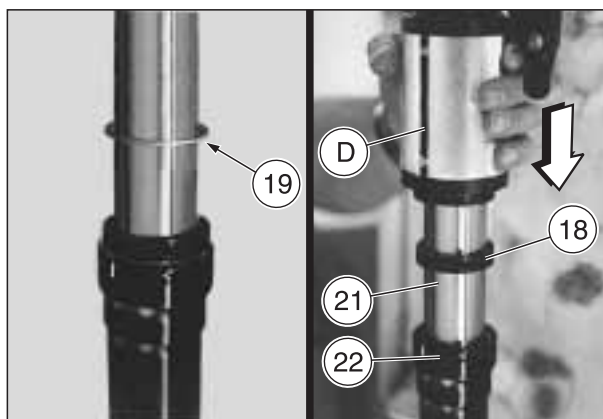
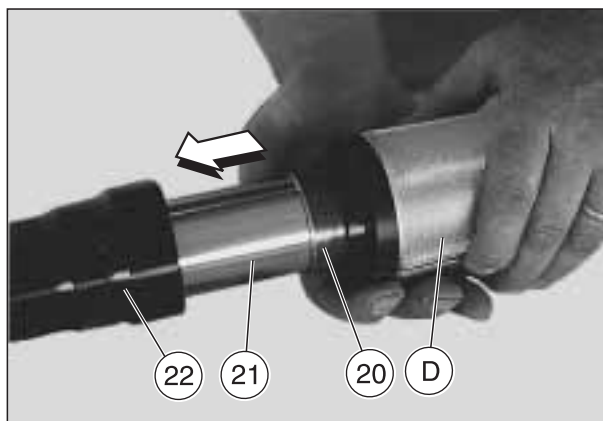

Follow ►

- ◆ * Grasp the slider (22) and make it slide slowly and alternately, with a stroke of approx. 150 mm, about 10 times, thus letting out all the air that is inside the slider.
- ◆ * Push the slider (22) to the end of its stroke.
- ◆ * Wait for a few minutes and check the oil level again; top up if necessary.
- ◆ * Insert the following components in the tube (21) in the given order:
 - lower collar (14);
 - spring rest washer (13);
 - spring (11);
 - spring pressing tube (6) complete with spring pressing element;
 - sliding ring (10);
 - washer (8).
- ◆ * Unscrew and remove the threaded pin (A1) from the tool (A).
- ◆ * Position the fixed part of the tool (A) on the spring pressing tube (6), so that the tooth fits in the hole.
- ◆ * Position the threaded pin (A1) in the hole on the fixed part of the tool (A), making sure that when screwed completely it fits in the hole on the spring pressing tube (6).

Follow ►

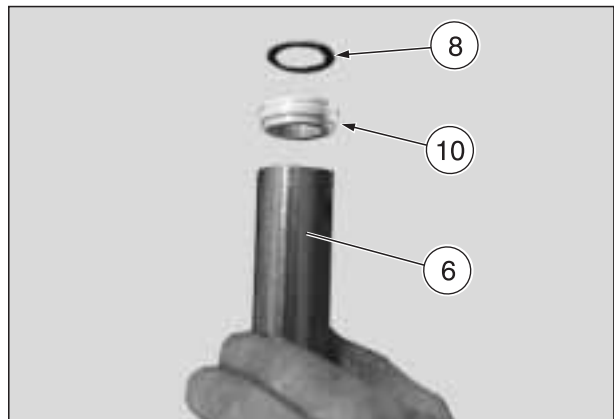
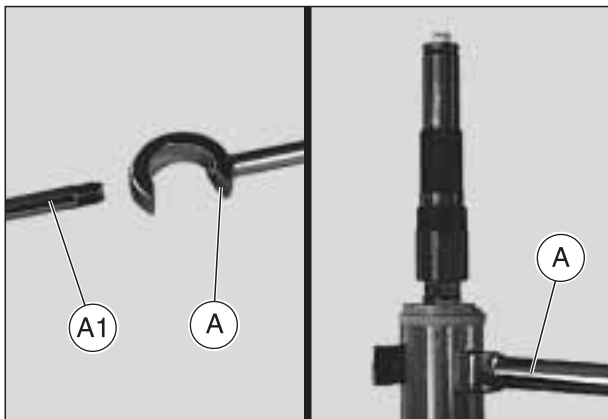
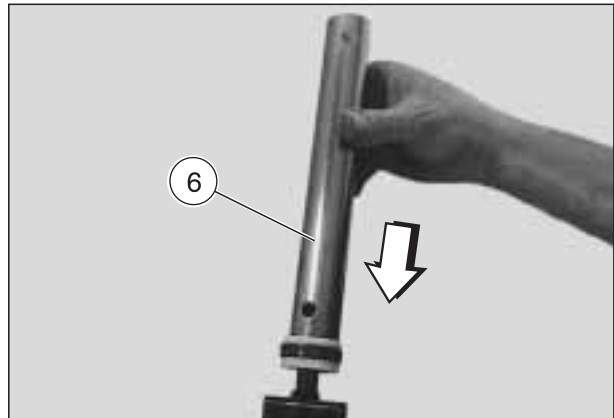
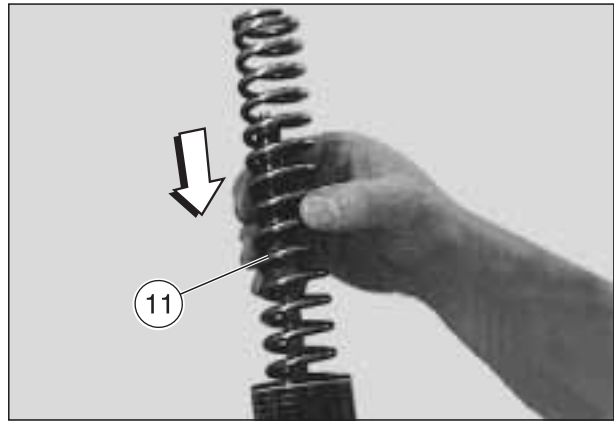
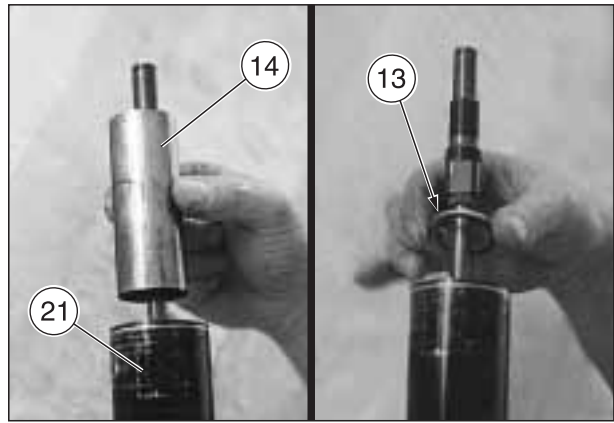

Follow ►

⚠ CAUTION

The following operations must be performed by two persons.

Fix the operating procedure before starting work.

- ◆ * Rest both hands on the tool (A).
- ◆ * Push downwards and at the same time insert the tool (B) between the locking nut (7) and the washer (8).
- ◆ * Keeping the pumping element (9) still, tighten the slider upper plug (5) on the pumping element (9) by means of a fork spanner inserted in the appropriate seat.

Slider upper plug / pumping element (9) driving torque (5): 35 Nm (3.5 kgm).

- ◆ * Rest both hands on the tool (A).
- ◆ * Push downwards and at the same time withdraw the tool (B).
- ◆ * Remove the tool (A).
- ◆ * Position the wheel-holder tube - slider unit on a vice, interposing the two half-shells of the special tool (C).
- ◆ * Screw and tighten the slider upper plug (5) on the slider.

Slider upper plug (5) / slider driving torque: 35 Nm (3.5 kgm).

- ◆ * Insert the spring preload pushing element (4).
- ◆ * Screw the adjusting element (3).
- ◆ * Position the stop ring (2) in its seat.
- ◆ * Act on the adjusting element (3) and on the adjuster (1) to restore the correct attitude, which must be the same as that of the other wheel-holder tube - slider unit, see 2.29.2 (ADJUSTING THE FRONT FORK).

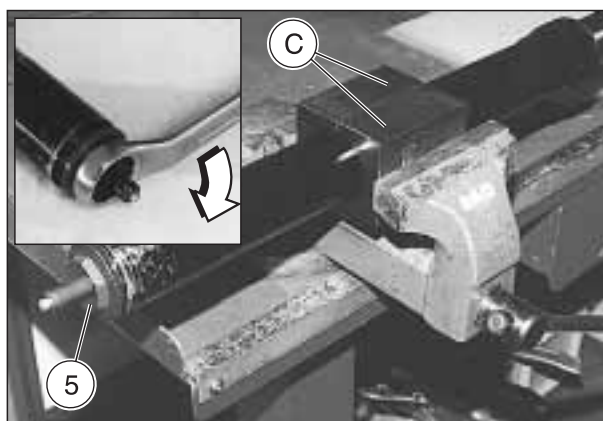
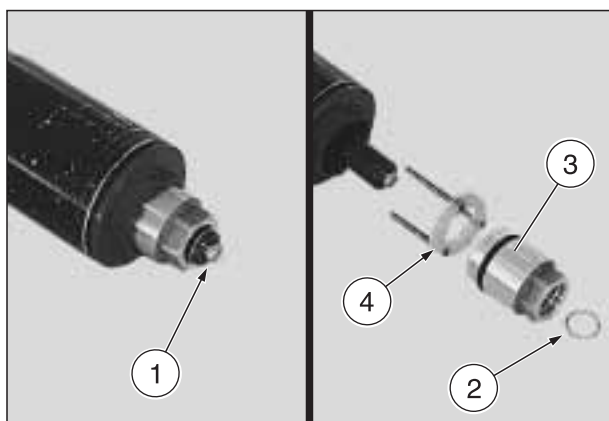
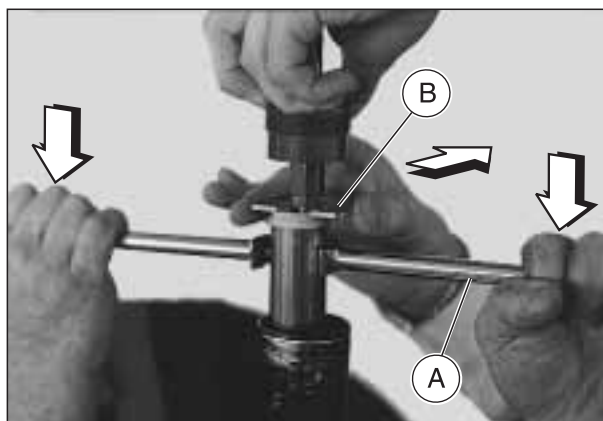
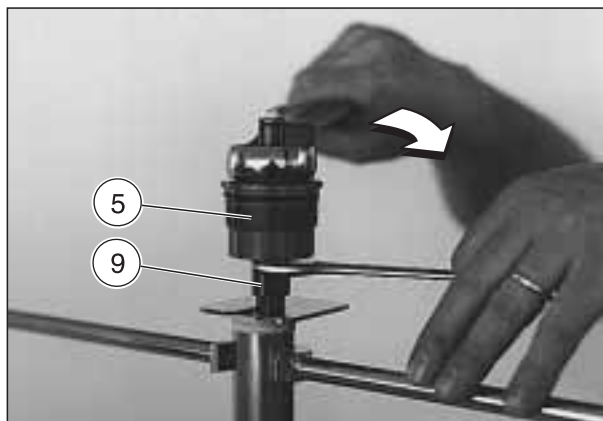
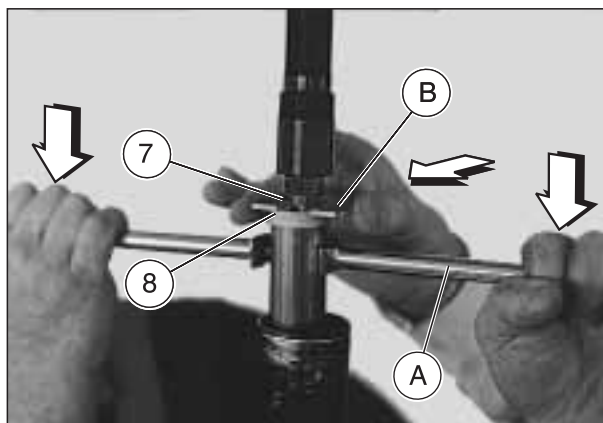

7.8.6 INSTALLING THE WHEEL-HOLDER TUBE - SLIDER UNITS

Carefully read 0.5.1 (PRECAUTIONS AND GENERAL INFORMATIONS) and 2.29 (INSPECTING THE FRONT AND REAR SUSPENSION).

- ◆ Insert the slider (1) complete with the wheel-holder tube (2) on the lower plate (3) and on the upper plate (4).
- ◆ Insert the wheel pin (5) on both tubes in order to align the hole of the wheel-holder tube (2) with the hole of the other wheel-holder tube.
- ◆ Make sure that the slider (1) is correctly inserted on the lower plate (3) and on the upper plate (4).

NOTE There are six notches to be found in the upper part of each fork slider, to be used as reference for the six different positions possible (see figure).

- ◆ Check the correspondence of the special notches made on the fork sliders on the fork upper plate, the number of notches (A) must correspond to the number counted upon disassembly.

CAUTION

The upper plate must be lined up with the same reference notch on both fork sliders.

- ◆ Tighten the two screws (6) that fix the lower plate (3) to the slider (1).

Screws (6) driving torque: 25 Nm (2.5 kgm).

- ◆ ★ Tighten the screw (7) that fixes the handlebar (8) to the slider (1).

Screw (7) driving torque: 25 Nm (2.5 kgm).

- ◆ Tighten the screw (9) that fixes the upper plate (4) to the slider (1).

Screw (9) driving torque: 25 Nm (2.5 kgm).

- ◆ Withdraw the wheel pin (5).
- ◆ Reassemble the wheel, see 7.2.1 (REMOVING THE FRONT WHEEL).
- ◆ Set the vehicle on the relevant front support stand, see 1.8.3 (POSITIONING THE VEHICLE ON THE FRONT SUPPORT STAND **OPT**).
- ◆ Remove the vehicle from the centre support stand.

CAUTION

After the reassembly, operate the front brake and thrust the fork repeatedly downwards. The operation must be smooth and progressive and there must be no trace of oil on the tubes.

WARNING

Before using the vehicle, check to make sure the riding position is correct, see 2.29.2 (ADJUSTING THE FRONT FORK).

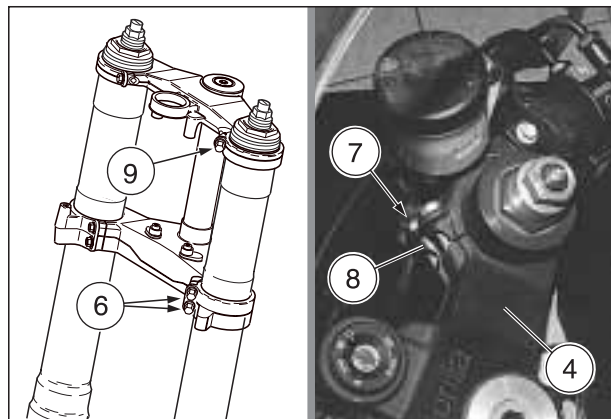
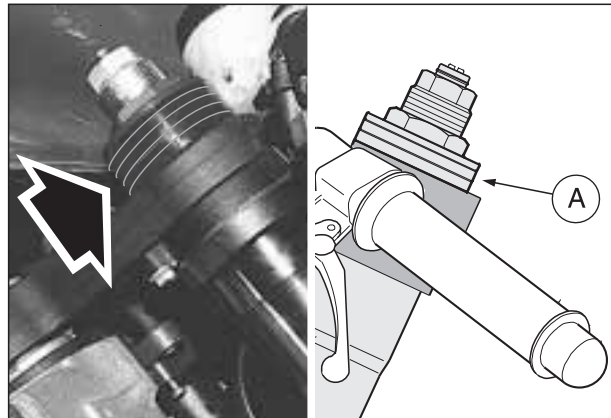
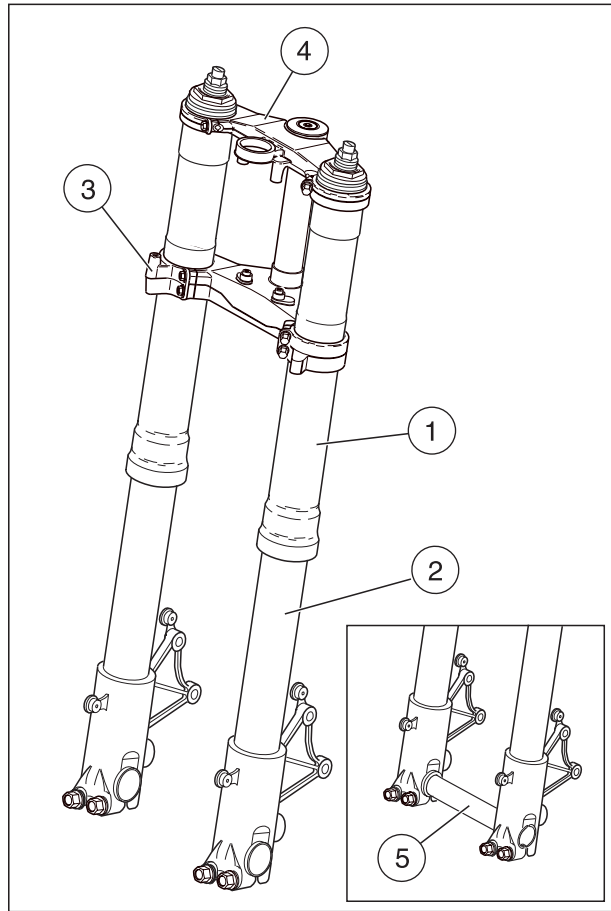

7.9 REAR FORK

7.9.1 REMOVING THE REAR FORK

Carefully read 0.5.1 (PRECAUTIONS AND GENERAL INFORMATIONS) and 2.30 (REAR FORK).

Choose the type of removal according to the operating needs.

- Type “A” removal:
for the inspection or change of the components that connect the rear fork to the frame; the chain (2) can remain connected to the rear fork.
- Type “B” removal:
for the replacement of the rear fork; the chain (2) must be opened.

Once the type of removal has been chosen, proceed as follows.

- ◆ Position the vehicle on the special centre stand (1), see 1.8.4 (POSITIONING THE VEHICLE ON THE CENTRE SUPPORT STAND **OPT**).
- ◆ Remove the rear wheel, see 7.3.1 (REMOVING THE REAR WHEEL).

NOTE Even if it is not necessary for the removal of the rear wheel, the rear support stand **OPT** (3) is indispensable to support the rear fork when the rear wheel has been removed.

Put a shim under the support base of the rear support stand **OPT** (3), in order to place it in operating position (hooked to the two pins on the rear fork).

- ◆ Unscrew and remove the screws (4) securing the profiled guard (5) and retrieve the two washers (6).
- ◆ Take and carefully rest on the ground, beside the vehicle, the support plate (7) complete with brake caliper (8) and the speed sensor (9), which are connected to the pipe and to the cable, respectively.

⚠ CAUTION

Do not pull the brake lever once the pads have been removed as the caliper pins are liable to come out of their slot, resulting in the spillage of brake fluid.

- ◆ Unscrew and remove the double connection element/rear fork nut (10).

Driving torque of the nut that fastens the double connection element to the rear fork (10): 50 Nm (5.0 kgm).

- ◆ Withdraw the double connection element/rear fork screw (11).

Follow ►

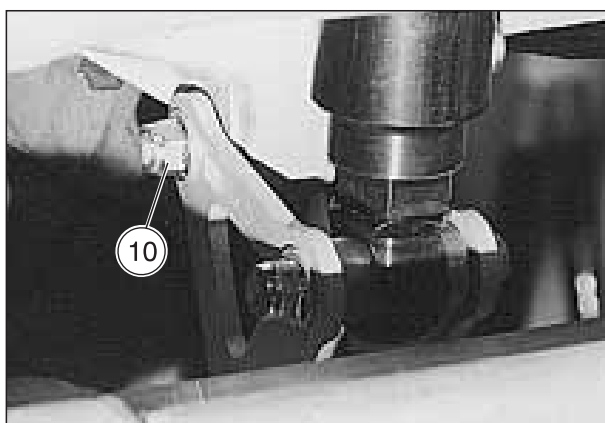
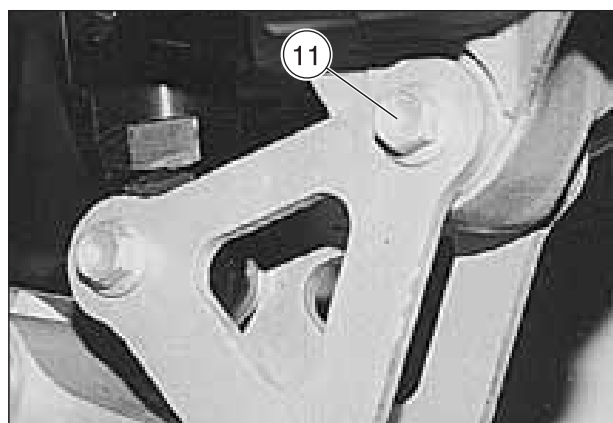
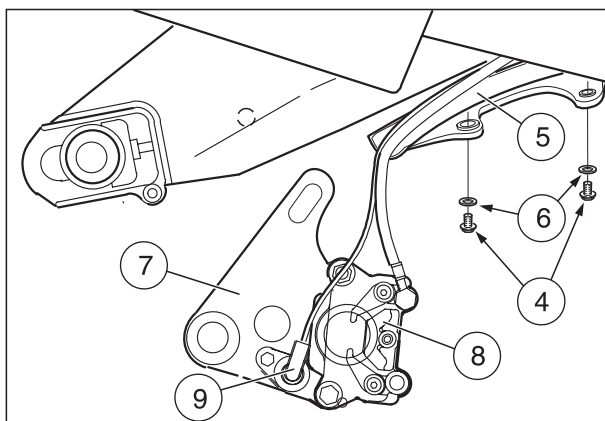
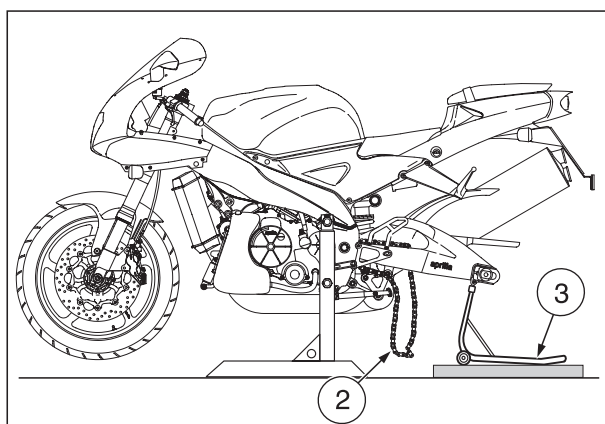
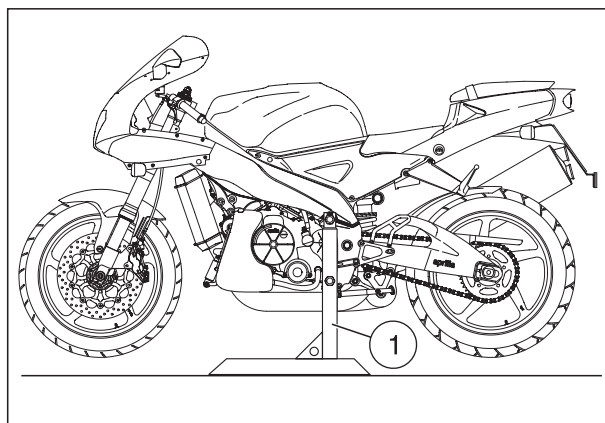

Follow ►

NOTE (X) For the reassembly the rear fork, from this point on follow the specific procedures, see 7.9.7 (REASSEMBLING THE REAR FORK).

For type “A” removal only.

- ◆ Remove the drive pinion, see 7.1.53 (REMOVING THE DRIVE PINION).

For type “B” removal only.

- ◆ Disjoin the drive chain, see 7.11 (DISASSEMBLING THE DRIVING CHAIN).

NOTE Do not carry out the first operation described in Ch. 7.11.2 (BREAKING THE CHAIN).

- ◆ Unscrew and remove the nut (12) and retrieve the washer (13).

NOTE Have the appropriate special tool **OPT** to hand:
 – **aprilia** part# 8140191 (rear fork pin and engine support tightening tool).

- ◆ Use the special setscrew spanner to loosen and remove the lock ring (14).
- ◆ Working from the right-hand side of the vehicle, rotate the fork pin (15) anticlockwise, which will cause the adjuster bush (16) to rotate with it, causing it to loosen completely.

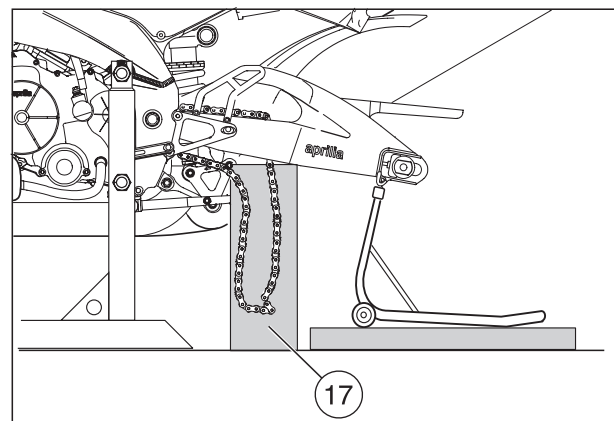
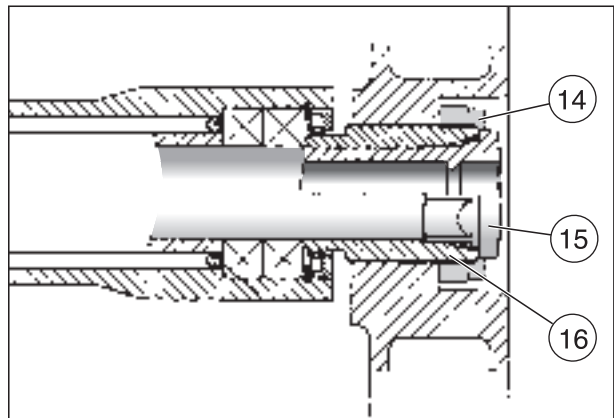
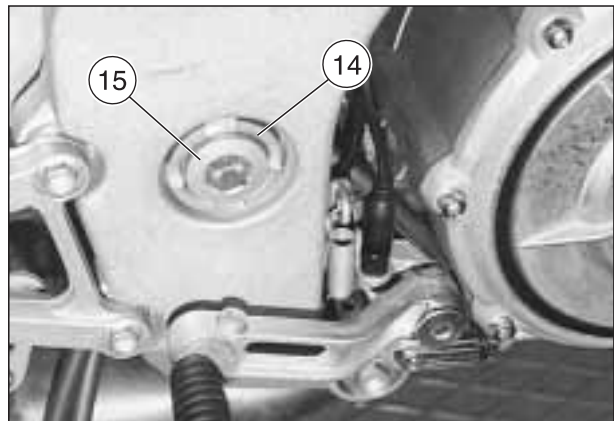
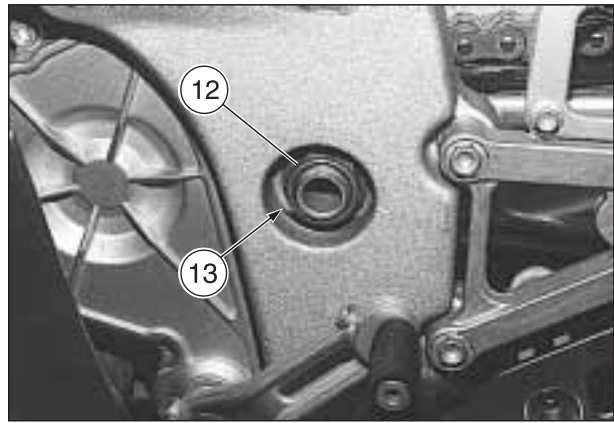

⚠ CAUTION

PROCEED WITH THE MAXIMUM CARE.
 The removal must be carried out with the greatest care.
 Support the fork from the front to prevent it accidentally dropping.

⚠ WARNING

Position a wooden support under the front part of the rear fork, to prevent it from lowering and hold it in its position.

- ◆ Position a support (17) under the front part of the rear fork.
- ◆ Support the fork frontally.
- ◆ Slide the fork pin (15) out from the right.

⚠ CAUTION

During the removal of the rear fork, take care to prevent the drive chain from getting entangled.

- ◆ Support the front part of the rear fork and be ready to hold it during its movement.
- ◆ Using the rear support stand, withdraw the rear fork from behind until detaching it completely from the vehicle frame.
- ◆ Slide the adjuster bush (15) from the rear fork pin (16).

7.9.2 CHECKING THE COMPONENTS

⚠ CAUTION

Make sure that all the components are intact, particularly the following.

7.9.3 REAR FORK BEARINGS

Carry out the check with the bearings mounted on the rear fork.

CHECKING THE ROTATION

- ◆ Manually rotate the inner ring of each single bearing. The rotation must be regular, smooth and noiseless.

If one or both bearings is/are not in compliance with the check parameters:

- ◆ Change both rear fork bearings, see 7.9.6 (DISASSEMBLING THE REAR FORK GASKETS).

⚠ WARNING

Always change both bearings.

Always replace the bearings with bearings of the same type.

CHECKING THE END AND RADIAL PLAY

- ◆ Check the radial play and the end play.
 - End play: a minimum end play is allowed.**
 - Radial play: none.**

If one or both bearings is/are not in compliance with the check parameters:

- ◆ Change both rear fork bearings, see 7.9.6 (DISASSEMBLING THE REAR FORK GASKETS).

⚠ WARNING

Always change both bearings.

Always replace the bearings with bearings of the same type.

7.9.4 REAR FORK GASKETS

- ◆ Make sure the seals are intact; should they prove damaged or feature signs of excessive wear, change them.

⚠ WARNING

Always change both seals.

Always replace the gaskets with gaskets of the same type.

7.9.5 REAR FORK PIN

- ◆ Check the eccentricity of the fork pin (1) by means of a comparator. If the eccentricity exceeds the limit value, change the fork pin (1).

Maximum eccentricity: 0.3 mm.

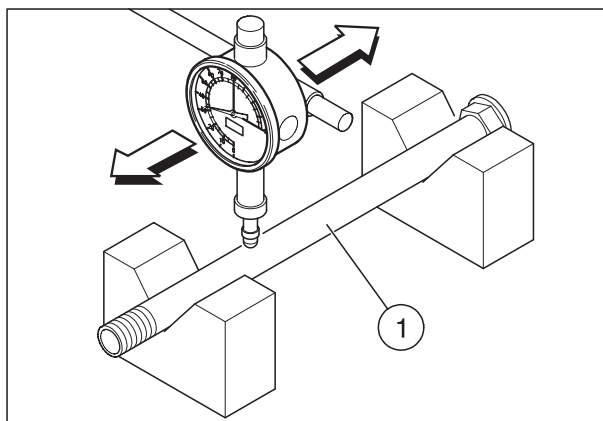

7.9.6 DISASSEMBLING THE REAR FORK GASKETS

Carefully read 0.5.1 (PRECAUTIONS AND GENERAL INFORMATIONS).

- ◆ Remove the fork, see 7.9.1 (REMOVING THE REAR FORK).
- ◆ Use a cloth to clean both sides of the bearing housings.
- ◆ Slide out the bush (1).
- ◆ Remove the seal (2).
- ◆ Remove the seal (3).
- ◆ Remove the snap ring (4).

NOTE Have the appropriate special tool **OPT** to hand:
 – **aprilia** part# 8140180 (bearing extractors).

- ◆ Use a special extractor to extract the two bearings (5) and roller bearing (6).

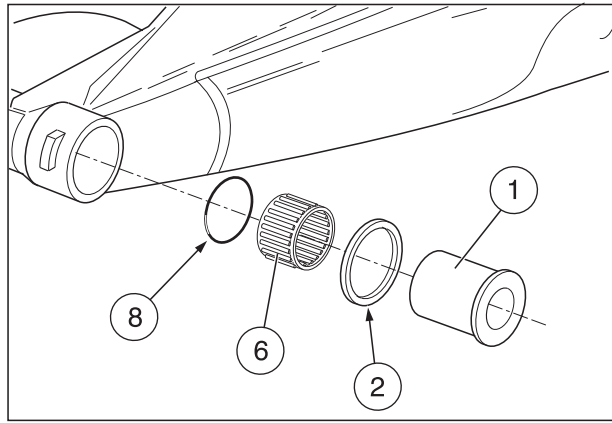

CAUTION

The bearings must be checked and, if necessary, changed every time they are disassembled.

- ◆ Remove the inner spacer (7) and retrieve the two O-rings (8).
- ◆ Remove the inner spacer (9).
- ◆ Remove the seals (10).
- ◆ Use a special extractor to extract the two roller bearings (11).

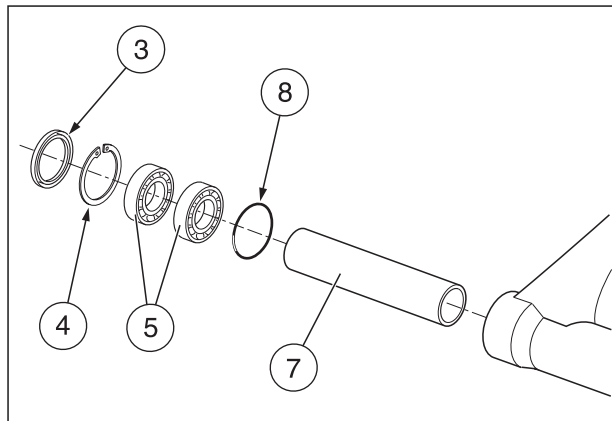

CAUTION

The bearings must be checked and, if necessary, changed every time they are disassembled.

- ◆ Thoroughly clean the inside of the bearing housing.

NOTE Wash all the components with a clean detergent.

CAUTION

When reassembling, use a drift with the same diameter as the outer race to insert the bearings. Do not strike the balls and/or the inner race.

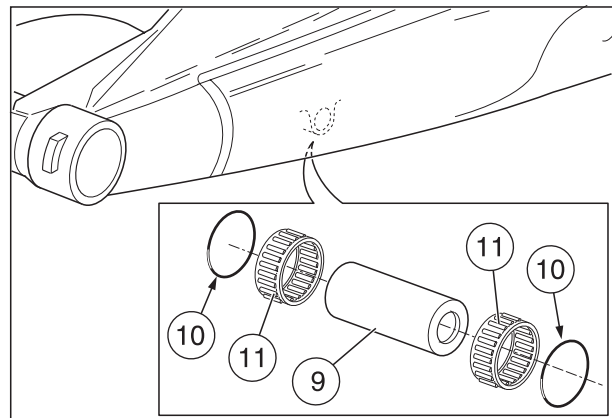

7.9.7 REASSEMBLING THE REAR FORK

Carefully read 0.5.1 (PRECAUTIONS AND GENERAL INFORMATIONS) and 2.30.1 (ADJUSTING THE REAR FORK).

- ◆ Smear a film of grease over the entire length of the fork pin, see 1.6 (LUBRICANT CHART).
- ◆ Insert the adjuster ring (1) in its slot and screw it on by hand.

NOTE The adjuster ring (1) must not stick out from the inside edge of the frame.

- ◆ Place the driving chain (2) on the front (left) part of the fork and fasten it in place with adhesive tape.

CAUTION

Position a wooden support (3) under the front part of the rear fork, to prevent it from lowering and hold it in its position.

- ◆ Support the rear part of the rear fork with the rear support stand (4).

NOTE Put a shim (5) under the support base of the rear support stand (4), in order to place it in operating position (hooked to the two pins on the rear fork).

- ◆ Support the fork from the front. Adjust its position so that the holes are aligned, at the same time pushing the pin (6) all the way in.

NOTE Make sure that the hex head of the pin (6) is correctly inserted in the hexagonal slot on the adjuster bush (7).

- ◆ Fit the lock ring (8) and screw it on by hand a few turns.
- ◆ Place the washer (9) and nut (10) on the pin, tightening them by hand.
- ◆ Now go ahead and adjust the rear fork, see 2.30.1 (ADJUSTING THE REAR FORK).
- ◆ Remove the adhesive tape, releasing the chain (2).
- ◆ Refit the chain (2) on the drive pinion (11).

NOTE Apply Anti-Seize LOCTITE® on the inner toothing of the drive pinion (11).

- ◆ Insert the pinion (11), complete with chain, on the shaft.

Follow ►

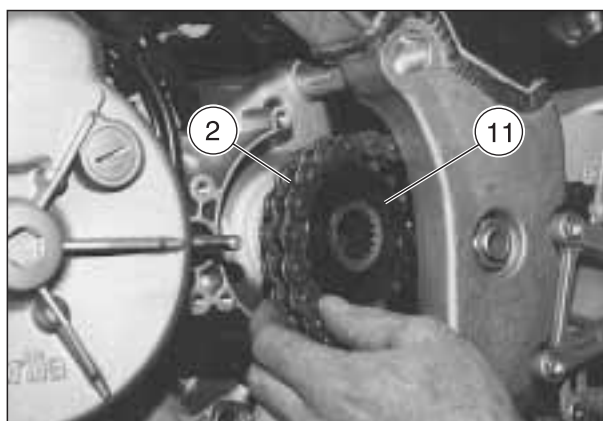
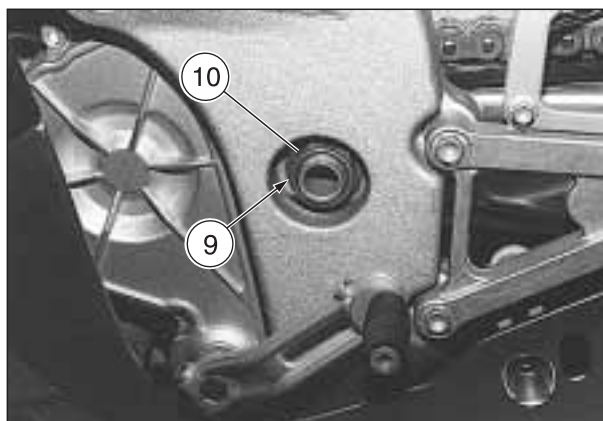
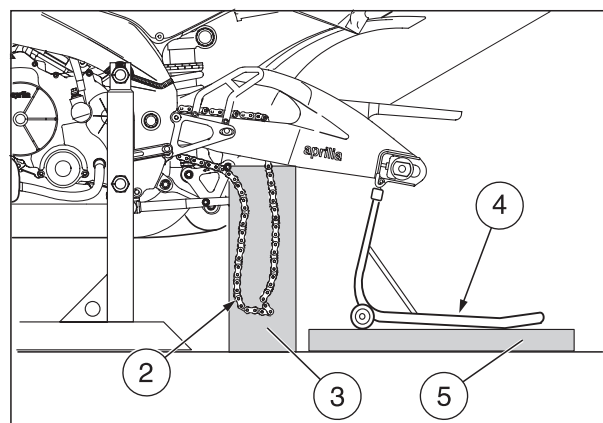
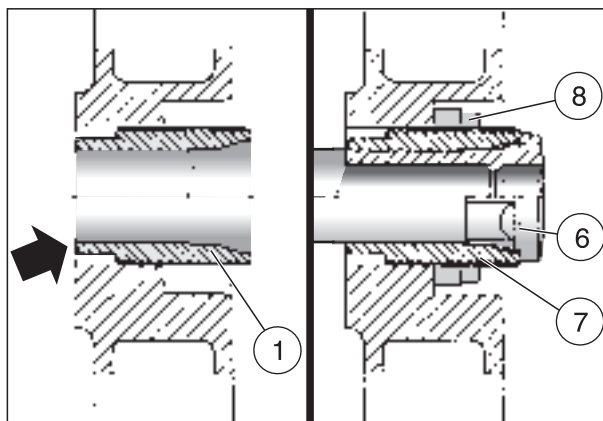

Follow ►

NOTE Apply LOCTITE® 243 on the thread of the screw (12).

- ◆ Insert the washer (13) and washer (14) on the screw (12).
- ◆ Screw and tighten the screw (12).

Screw (12) driving torque: 50 Nm (5.0 kgm).

- ◆ Fit the guide plate (15).
- ◆ Refit the pinion protection case (16).
- ◆ Screw and tighten the three screws (17).

Screws (17) driving torque: 10 Nm (1.0 kgm).

⚠ CAUTION

From this point on, reassemble the fork following the removal procedure in the reverse order, starting from NOTE (X), see 7.9.1 (REMOVING THE REAR FORK).

- ◆ Go ahead with the adjustment of the driving chain tension, see 2.36.3 (ADJUSTING THE DRIVING CHAIN).

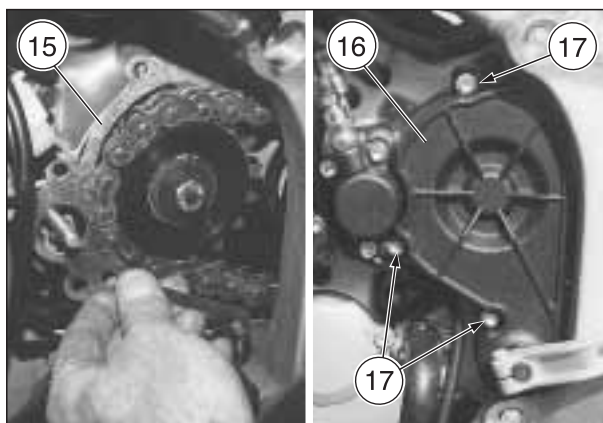
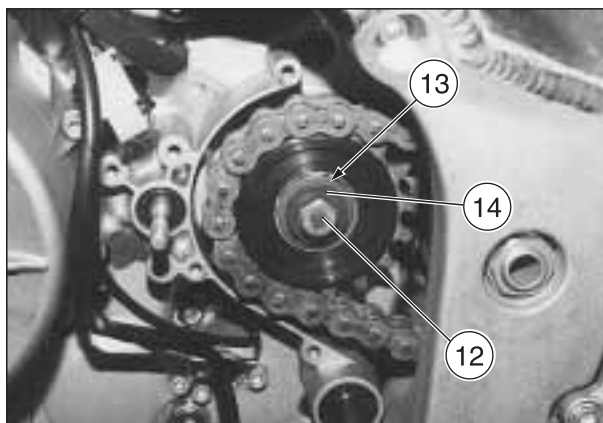

7.10 REAR SUSPENSION

7.10.1 REMOVING THE SHOCK ABSORBER (models up to 2001)

Carefully read 0.5.1 (PRECAUTIONS AND GENERAL INFORMATIONS) and 2.31.1 (REAR SUSPENSION).

- ◆ Position the vehicle on the special centre stand, see 1.8.4 (POSITIONING THE VEHICLE ON THE CENTRE SUPPORT STAND **opt**).
- ◆ Place a support under the rear wheel so that the rear wheel touches lightly on the support and the shock absorber is in the idle position.
- ◆ Remove the lower fairing, see 7.1.34 (REMOVING THE LOWER FAIRING).
- ◆ Remove the side panels, 7.1.3 (REMOVING THE SIDE COVERS).
- ◆ Working from the left-hand side of the vehicle, loosen and remove the nut (1) and push the screw (2) out partially.

Nut (1) driving torque: 50 Nm (5.0 kgm).

- ◆ Pull the screw (2) out from the opposite side.
- ◆ Working from the right-hand side of the vehicle, loosen and remove the nut (3).

Nut (3) driving torque: 50 Nm (5.0 kgm).

- ◆ Pull the screw (4) out from the opposite side.

CAUTION

The shock absorber contains pressurized nitrogen. In order to avoid the risk of an explosion, keep it away from flames and/or sources of heat. In the event the shock absorber is to be replaced, discharge the nitrogen by pressing the central core of the valve under the cap (5).

- ◆ Grip the shock absorber (5) and remove it by pulling it up and at the same time rotating it backwards.
- ◆ Slide the spacer (7), to be found on the shock absorber's upper attachment fork, inwards.
- ◆ Slide the two bushes (8) and two O-rings (9) from the upper attachment.
- ◆ Slide the two bushes (10) and two O-rings (11) from the lower attachment.

NOTE Wash all the components with a clean detergent.

- ◆ Check the components, see 7.10.3 (CHECKING THE COMPONENTS).

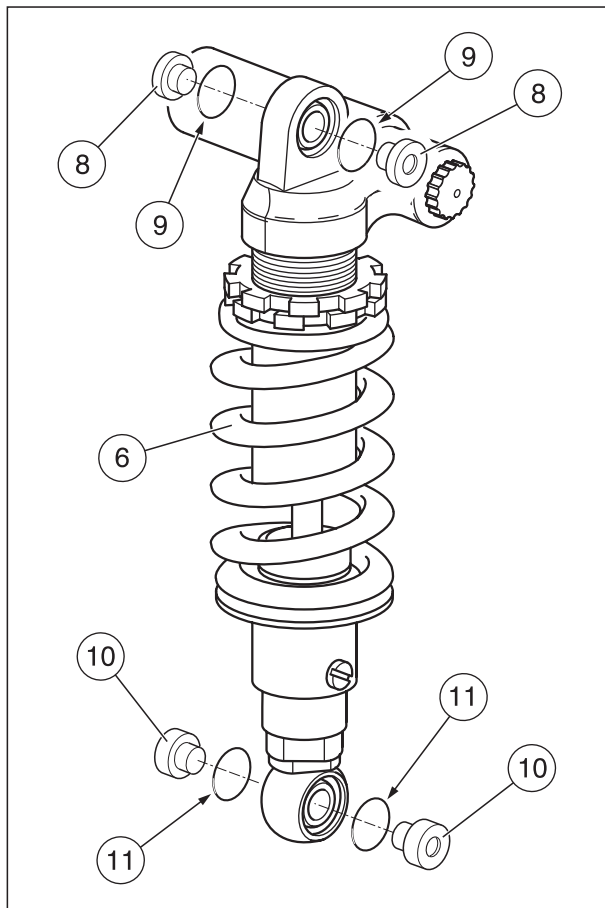
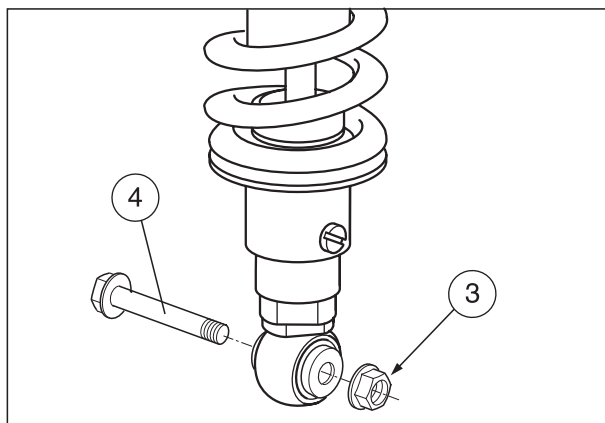
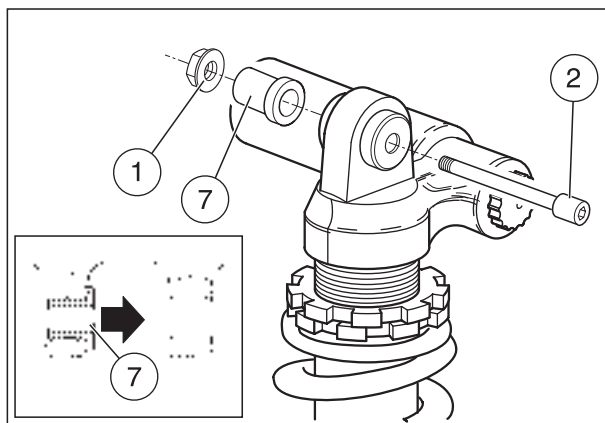
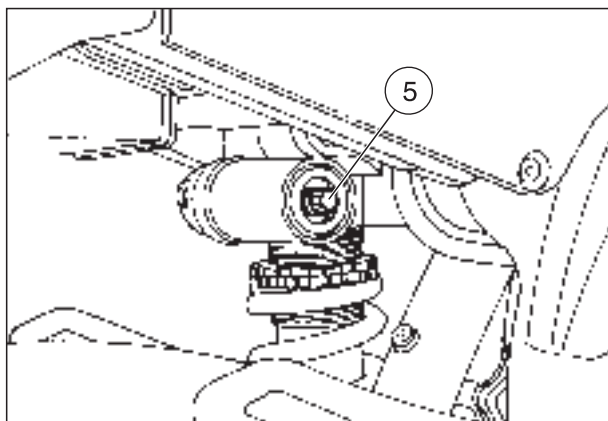

7.10.2 REMOVING THE SHOCK ABSORBER **RSV 01**

Carefully read 0.5.1 (PRECAUTIONS AND GENERAL INFORMATIONS) and 2.31.1 (REAR SUSPENSION).

- ◆ Position the vehicle on the special centre stand, see 1.8.4 (POSITIONING THE VEHICLE ON THE CENTRE SUPPORT STAND **Opt**).
- ◆ Place a support under the rear wheel so that the rear wheel touches lightly on the support and the shock absorber is in the idle position.
- ◆ Remove the lower fairing, see 7.1.34 (REMOVING THE LOWER FAIRING).
- ◆ Remove the side panels, see 7.1.3 (REMOVING THE SIDE COVERS).
- ◆ Working from the left-hand side of the vehicle, loosen and remove the nut (1) and push the screw (2) out partially.

Nut (1) driving torque: 50 Nm (5.0 kgm).

- ◆ Pull the screw (2) out from the opposite side.
- ◆ Working from the right-hand side of the vehicle, loosen and remove the nut (3).

Nut (3) driving torque: 50 Nm (5.0 kgm).

- ◆ Pull the screw (4) out from the opposite side.

CAUTION

The shock absorber contains pressurized nitrogen. In order to avoid the risk of an explosion, keep it away from flames and/or sources of heat. In the event the shock absorber is to be replaced, discharge the nitrogen by pressing the central core of the valve under the screw (5).

- ◆ Grip the shock absorber (5) and remove it by pulling it up and at the same time rotating it backwards.
- ◆ Slide the spacer (7), to be found on the shock absorber's upper attachment fork, inwards.
- ◆ Slide the two bushes (8) and two O-rings (9) from the upper attachment.
- ◆ Slide the two bushes (10) and two O-rings (11) from the lower attachment.

NOTE Wash all the components with a clean detergent.

- ◆ Check the components, see 7.10.3 (CHECKING THE COMPONENTS).

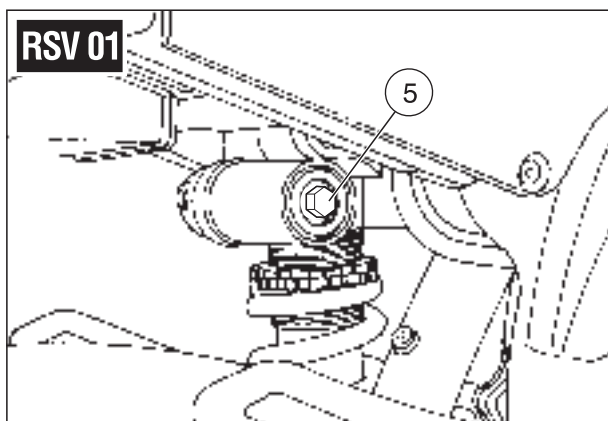
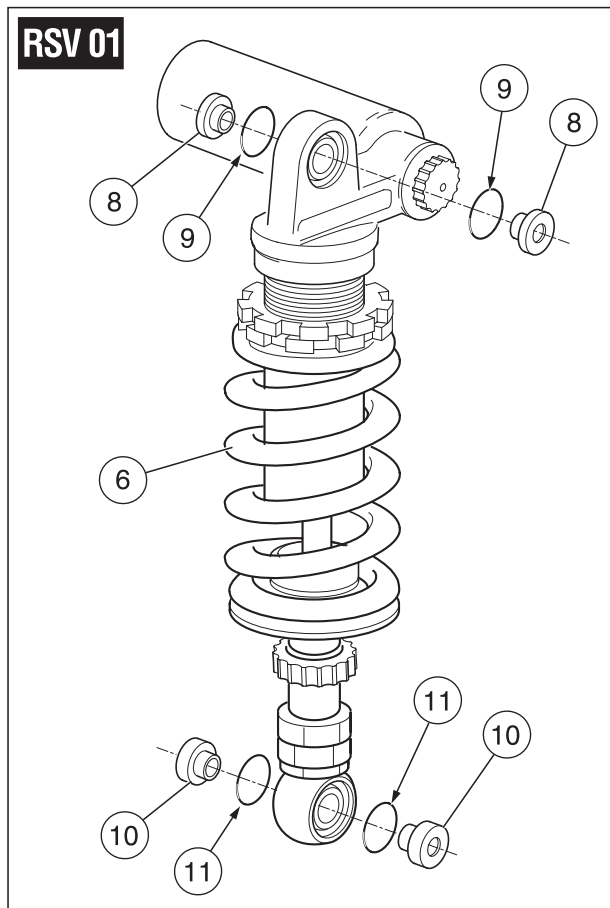
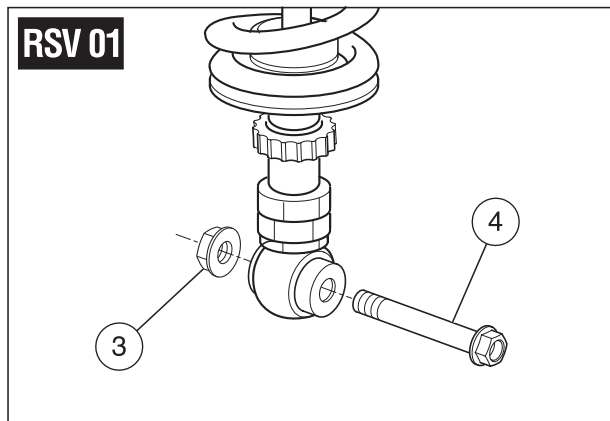
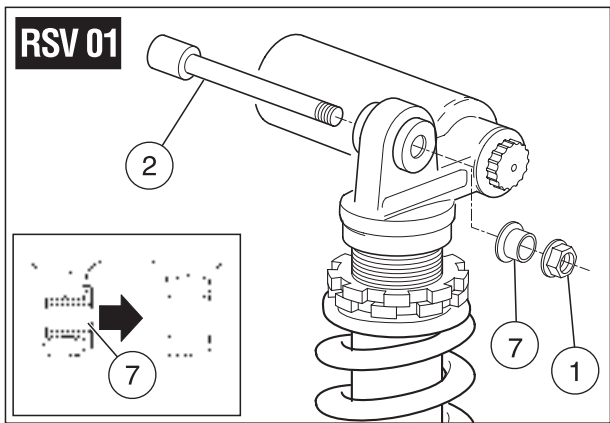

7.10.3 CHECKING THE COMPONENTS

⚠ CAUTION

Make sure that none of the components appear to be visibly distorted, broken, cracked and/or dented.

Replace any damaged components.

BEARINGS

- ◆ Manually rotate the rollers. It should rotate smoothly without jamming and/or noise. There should be no end play. Any bearings featuring said defects should be changed.

⚠ CAUTION

Apply grease on the rollers, see 1.6 (LUBRICANT CHART).

SEALS

- ◆ Make sure the seals are intact; should they prove damaged or feature signs of excessive wear, change them.

SHOCK ABSORBER

- ◆ Make sure that there are no oil leaks from the shock absorber and that its travel is smooth and gradual. If this is not the case, change the shock absorber.

⚠ WARNING

The shock absorber contains pressurized nitrogen. In order to avoid the risk of an explosion, keep it away from flames and/or sources of heat.

In the event the shock absorber is to be replaced, discharge the nitrogen by pressing the central core of the valve under the cap (1) or under the screw (2).

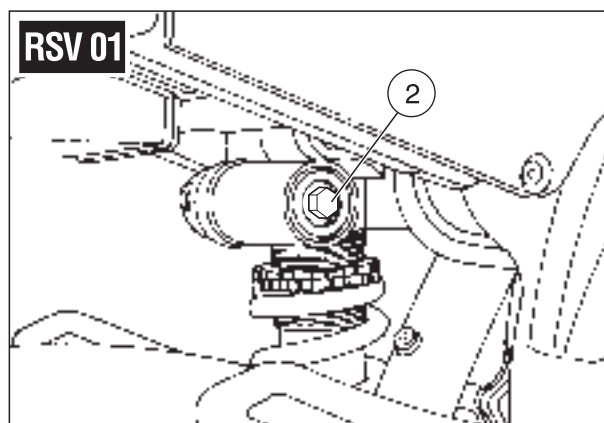
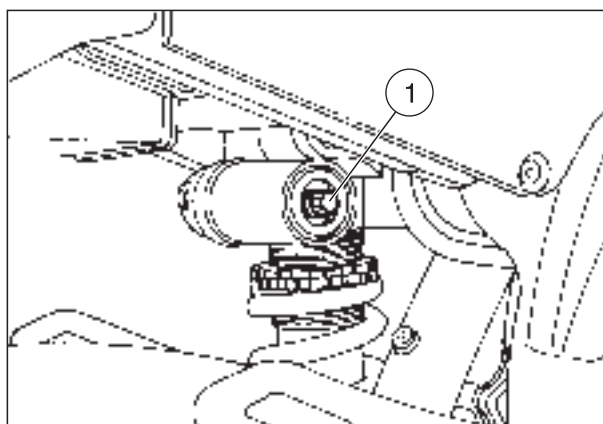

7.10.4 DISASSEMBLING THE REAR SUSPENSION LINKAGE

Carefully read 0.5.1 (PRECAUTIONS AND GENERAL INFORMATIONS) and 2.31.1 (REAR SUSPENSION).

- ◆ Working from the right-hand side of the vehicle, loosen and remove the nut (1).

Nut (1) driving torque: 50 Nm (5.0 kgm).

- ◆ Pull the screw (2) out from the opposite side.
- ◆ Loosen and remove the nut (3).

Nut (3) driving torque: 50 Nm (5.0 kgm).

- ◆ Pull the screw (4) out from the opposite side.
- ◆ Loosen and remove the nut (5).

Nut (5) driving torque: 50 Nm (5.0 kgm).

- ◆ Pull the screw (6) out from the opposite side.
- ◆ Remove the whole suspension linkage unit (7).

NOTE When reassembling, grease the linkage fulcrum points, see 1.6 (LUBRICANT CHART), and be extremely careful to refit the components correctly, making sure that the joints move smoothly.

- ◆ Once reassembly is complete, check the assembly, see 2.32.3 (CHECKING THE REAR SUSPENSION LINKAGE).

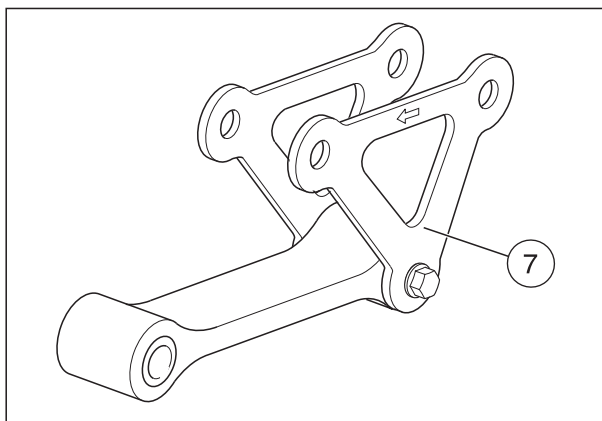
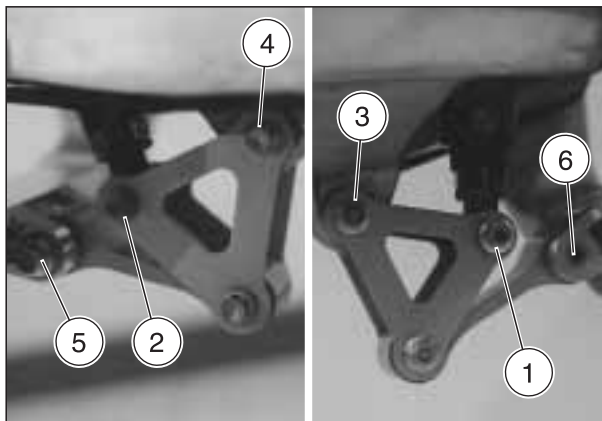

7.10.5 DISASSEMBLING THE SUSPENSION LINKAGE

Carefully read 0.5.1 (PRECAUTIONS AND GENERAL INFORMATIONS).

- ◆ Loosen and remove the nut (8).

Nut (8) driving torque: 50 Nm (5.0 kgm).

- ◆ Slide out the screw (9).
- ◆ Remove the two double connecting rods (10) (11).
- ◆ Remove the two seals (12).
- ◆ Extract the two roller bearings (13).
- ◆ Remove the inner spacer (14).
- ◆ Remove the two seals (15).
- ◆ Remove the inner spacer (16).
- ◆ Extract the two roller bearings (17).

NOTE Wash all the components with a clean detergent.

NOTE When reassembling, connect the single connecting rod (18) to the double connecting rods (10) (11) as illustrated in the figure; the arrow inscribed on the top side must face in the direction of travel.

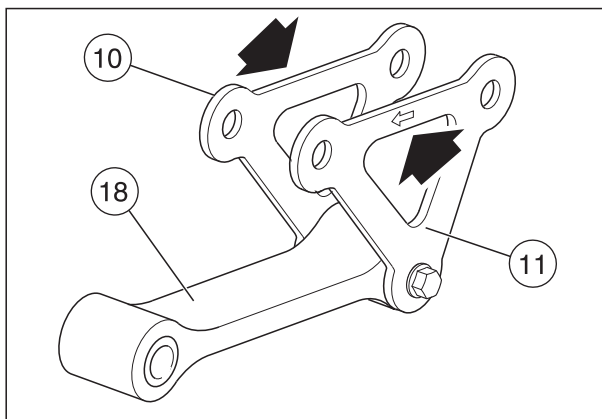
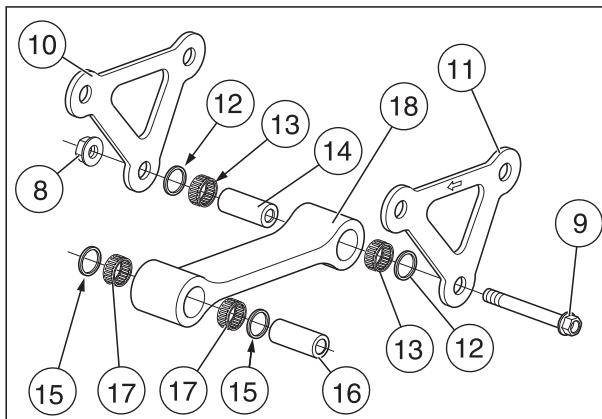

7.11 DISASSEMBLING THE DRIVING CHAIN

7.11.1 CHAIN BREAKER/RIVET TOOL OPT

NOTE Have the appropriate special tool OPT to hand:
 – **aprilia** part# 8140192 (chain installation kit).

NOTE This tool is designed for breaking/rejoining chains with rivet-type connecting links.

⚠ CAUTION

Only rivet-type connecting link chains should be fitted on this vehicle.

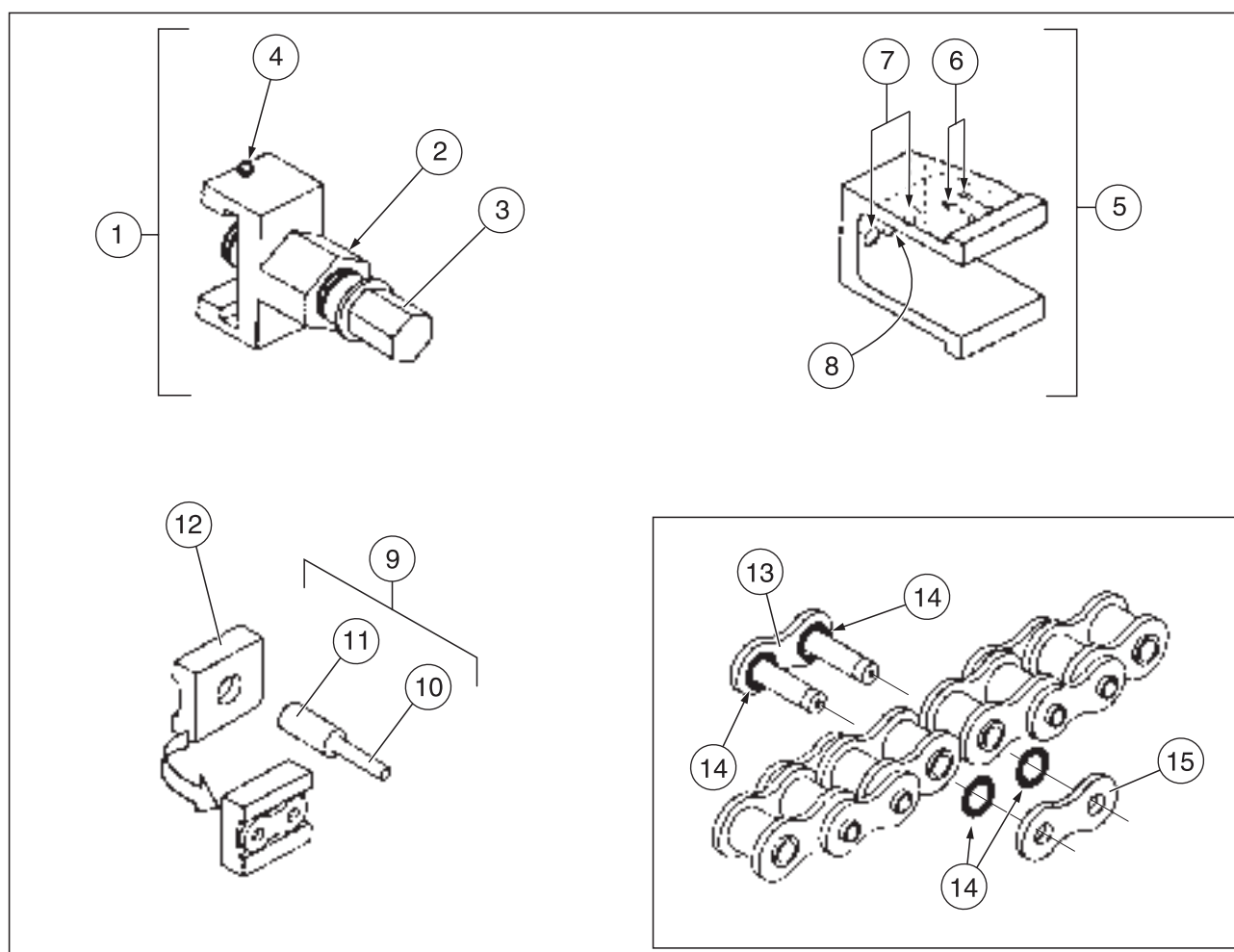

Key

- | | |
|---|--|
| <ul style="list-style-type: none"> 1) Main body 2) Fixed hexagonal seat (for 27 mm spanner) 3) Hex-head screw (for 19 mm spanner) 4) Locating dowel 5) Rivet tool 6) "A" and "B" reference marks 7) Positioning holes for joining pins 8) Pin exit hole | <ul style="list-style-type: none"> 9) Pusher 10) Breaking side 11) Joining side 12) Support plate 13) Joining plate 14) O-rings 15) Rivet plate |
|---|--|

7.11.2 BREAKING THE CHAIN

Carefully read 0.5.1 (PRECAUTIONS AND GENERAL INFORMATIONS) and 2.36 (DRIVE CHAIN).

- ◆ Remove the pinion protection case, see 2.36.5 (INSPECTING THE DRIVING CHAIN GUIDE PLATE).
- ◆ Slacken the chain, see 2.36.3 (ADJUSTING THE DRIVING CHAIN).
- ◆ Position the vehicle on the appropriate rear support stand, see 1.8.2 (POSITIONING THE VEHICLE ON THE REAR SUPPORT STAND **OPT**).

NOTE Make sure the tool is suitable for the chain type fitted on the vehicle and for the size of the chain's links.

- ◆ Place the rivet tool (1) on the chain at a point between the sprocket and pinion, on the chain's lower course.
- ◆ Move the rivet tool (1) so that its pin exit hole (the one in the centre) is lined up with the pin on the chain to be pushed out.
- ◆ Insert the pusher (2) on the main body (3), with the part featuring the greatest diameter first.
- ◆ Fit the main body (3) on the rivet tool (1).
- ◆ Move the main body (3) so that the locating dowel (4) is in line with mark "A" on the rivet tool (1).
- ◆ Turn the screw (5) by hand until the pusher (2) touches the pin to be pushed out.

NOTE Make sure the pusher (2) is perfectly in line with the pin to be pushed out.

- ◆ Use a 27 mm spanner, inserted on the fixed hexagonal seat of the central body (3), to hold the body still.
- ◆ Use a 19 mm spanner to turn the screw (5) until the pin on the chain is pushed out completely.
- ◆ Loosen the screw (5).
- ◆ Repeat the procedure, moving on to the adjacent pin on the same link.
- ◆ Remove the components of the disconnected link and the four O-rings.
- ◆ Remove the chain.

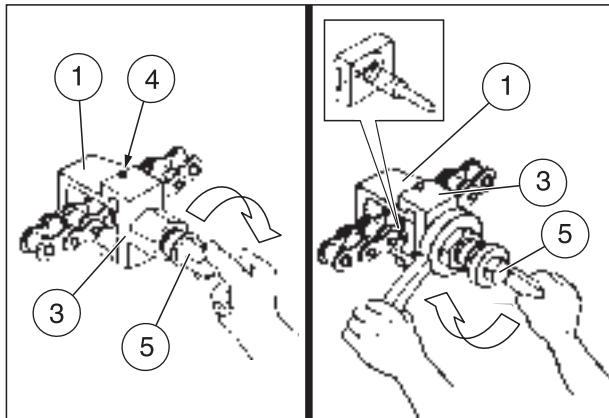
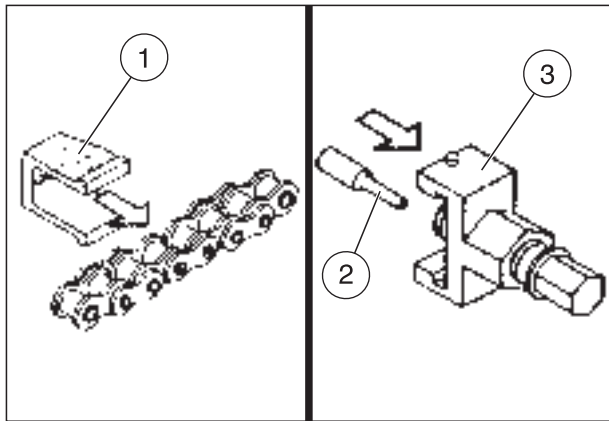

CAUTION

If the chain appears particularly worn, replace the whole unit (pinion, sprocket and chain), see 7.3.2 (REMOVING THE FINAL DRIVE UNIT).

7.11.3 POSITIONING THE JOINING LINK

⚠ CAUTION

Make sure the joining link is of the same type as the chain to be joined up.

- ◆ Position the chain on the vehicle with the two ends to be joined up at a point between the sprocket and pinion on the chain's lower course.
- ◆ Insert the two O-rings on the pins of the joining plate.
- ◆ Grease the two pins on the joining plate, see 1.6 (LUBRICANT CHART).
- ◆ Join together the two ends of the chain and insert the joining plate pins.
- ◆ Insert the two O-rings on the ends of the pins.
- ◆ Insert the rivet plate on the pins.
- ◆ Fit the support plate (6) on the rivet plate.
- ◆ Fit the rivet tool (1) on the chain.
- ◆ Move the rivet tool (1) so its holes (the ones at the side) are lined up with the heads of the pins on the joining plate.
- ◆ Insert the pusher (2) on the main body (3), with the area featuring the smallest diameter first.
- ◆ Fit the main body (3) on the rivet tool (1).
- ◆ Move the main body (3) so that the locating dowel (4) is in line with mark "A".
- ◆ Turn the screw (5) by hand until the pusher (2) touches the support plate (6).
- ◆ Use a 27 mm spanner, inserted on the fixed hexagonal seat of the central body (3), to hold the body still.
- ◆ Use a 19 mm spanner to turn the screw (5) as far as it will go.

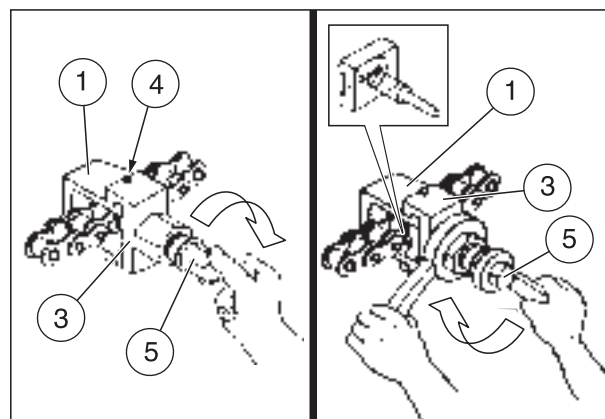
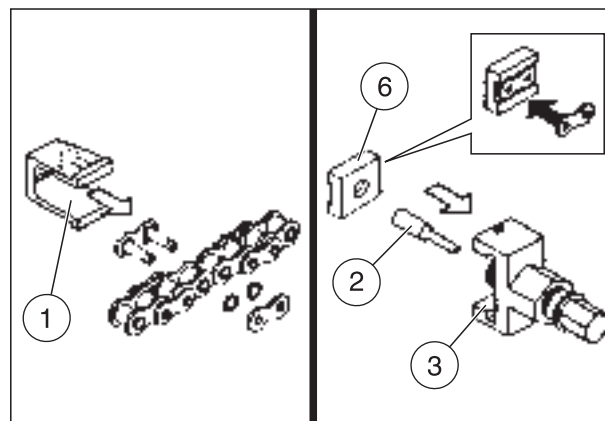

7.11.4 RIVETTING THE PINS

With the tool already in place on the chain:

- ◆ Loosen the screw (5).
- ◆ Remove the main body (3) from the rivet tool (1).
- ◆ Remove the support plate (6).
- ◆ Refit the main body (3) on the rivet tool (1).
- ◆ Move the main body (3) so that the locating dowel (4) is lined up with mark "B" on the rivet tool (1).
- ◆ Turn the screw (5) by hand until the pusher (2) touches the pin to be rivetted.

NOTE Make sure the pusher (2) is perfectly in line with the pin to be rivetted.

⚠ CAUTION

To have on goggles or glow screen for the eyes.

- ◆ Use a 27 mm spanner, inserted on the fixed hexagonal seat of the central body (3), to hold the body still.
- ◆ Use a 19 mm spanner to turn the screw (5) until the edge of the pin is rivetted.

⚠ CAUTION

Make sure that the rivetting on the pin has been performed correctly; the rivetted edge of the pin must touch the rivet plate evenly. The rivetted edge diameter must be 5.65 ± 0.15 mm max.

- ◆ Loosen the screw (5).

Repeat the procedure, moving on to the adjacent pin on the same link.

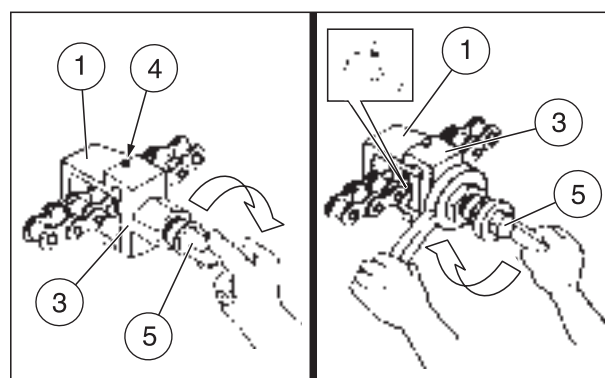
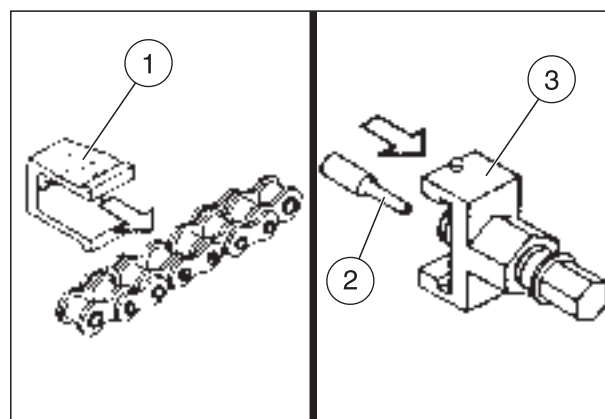

OK



REPAIR INFORMATION

8

REPAIR INFORMATION

TABLE OF CONTENTS

8.1 TROUBLESHOOTING	8-3-00
8.1.1 ENGINE	8-3-00
8.1.2 ELECTRIC SYSTEM	8-6-00
8.1.3 BATTERY	8-7-00
8.1.4 BRAKES	8-7-00
8.1.5 CHASSIS	8-8-00
8.2 RUN, FASTENING, WIRING, CABLES AND PIPES	8-9-00
8.2.1 FRONT BRAKE PIPES	8-9-00
8.2.2 REAR BRAKE PIPES	8-9-00
8.2.3 FUEL SYSTEM PIPES	8-10-00
8.2.4 CLUTCH CONTROL PIPE	8-11-00
8.2.5 PPC DEVICE PRESSURE PIPES	8-11-00
8.2.6 COOLING SYSTEM PIPES	8-12-00
8.2.7 ENGINE OIL PIPES	8-14-00
8.2.8 BREATHER AND IMPURITY DRAINAGE PIPES	8-15-00
8.2.9 ACCELERATOR CONTROL CABLES ..	8-16-00
8.2.10 COLD START CABLE	8-16-00
8.2.11 ELECTRIC CABLES	8-17-00
8.3 CHECKING THE ELECTRICAL SYSTEM	8-22-00
8.3.1 SPARK PLUGS (no spark)	8-22-00
8.3.2 BATTERY RECHARGING PROBLEMS	8-22-00
8.3.3 IGNITION AND/OR STARTING PROBLEMS	8-22-00
8.3.4 AUXILIARY SYSTEM PROBLEMS	8-22-00
8.4 TECHNICAL DATA AND SPECIFICATIONS	8-23-00
8.4.1 ENGINE	8-23-00
8.4.2 THROTTLE BODY COMPONENTS	8-23-00
8.4.3 SUPPLY SYSTEM	8-23-00
8.4.4 ELECTRIC SYSTEM	8-23-00
8.4.5 FRONT BRAKING SYSTEM	8-23-00
8.4.6 REAR BRAKING SYSTEM	8-23-00
8.4.7 COOLING SYSTEM	8-23-00
8.4.8 WHEELS	8-23-00
8.4.9 FRONT SUSPENSION	8-23-00
8.4.10 REAR SUSPENSION	8-23-00
8.4.11 STEERING	8-23-00
8.4.12 CAPACITIES - FLUID PROPERTIES ..	8-23-00
8.4.13 STRUCTURE (FRAME / SADDLE SUPPORT / DASHBOARD MOUNT) ..	8-23-00
8.4.14 EXHAUST SYSTEM	8-23-00

8.1 TROUBLESHOOTING

⚠ CAUTION

Any faults with the ignition coils, driving shaft position sensor, camshaft sensor, pressure sensors and thermistors are automatically detected by the engine control unit and reported on the multifunction display with the flashing message “EF!”.

For this reason, the malfunctions of these components are not repeated in the troubleshooting table; see relevant chapters in sect. 4 (FUEL SUPPLY SYSTEM) and sect. 6 (ELECTRIC SYSTEM).

NOTE In the following table, the operations marked with (*) must be carried out consulting the Engine service and repair manual, see 0.4.1 (ENGINE SERVICE AND REPAIR MANUALS).



8.1.1 ENGINE

DEFECT	SYMPTOM AND POSSIBLE CAUSES	REMEDY
The engine does not start or has trouble starting	Engine shutoff switch set to “⊗”	Set to “○”
	Starting safety logic not satisfied	Check and restore the necessary conditions
	Fall sensor faulty	Replace
	Vent hole on tank cap clogged	Clean
	Battery charge insufficient	Recharge
	Battery damaged	Replace
	Free-wheel, gear free-wheel worn or faulty	Replace (*)
	Double gear or intermediate gear of the starter motor worn or faulty	Replace (*)
	Starter motor toothing broken	Replace (*)
	Spark plugs dirty	Replace
	Spark plugs wet	Clean or replace
	Spark plugs loose	Tighten
	Spark plugs are not to spec.	Replace
	Cold start cable not working	Check
	Fuel filters dirty or fuel supply pipes clogged	Clean or replace
	Fuel pump, relay or wiring faulty	Replace
Fuel pressure regulator faulty	Replace	
Injectors faulty	Replace	
Valve clearance incorrect	Adjust (*)	
The engine has trouble idling	Idling rpm too low	Adjust
	Air cleaner dirty	Clean
	Intake coupling leaking	Replace
	Incorrect synchronization of both cylinders	Synchronize the cylinders
	Throttle body connection hoses damaged or cracked	Replace
	Throttle valve shaft/housing worn	Replace
	See the subsection entitled (The engine does not start or has trouble starting) for other possible causes	
The engine runs irregularly at higher speeds	Fuel outflow union clogged, which reduces the fuel supply to the injectors	Clean and resupply the fuel system
	Intake conveyors and pipes clogged	Check
	Air penetrating through the throttle body or intake coupling	Replace
	Fuel pressure too low	Clean fuel system or change pump.
	Fuel supply pump faulty	Replace
	Camshafts worn	Replace (*)
	See the subsection entitled (The engine does not start or has trouble starting) for other possible causes	

Follow ►

DEFECT	SYMPTOM AND POSSIBLE CAUSES	REMEDY
Engine lacks power	Spark plugs dirty	Clean or replace
	Spark plugs are not to spec.	Replace
	Insufficient valve clearance	Adjust (*)
	Exhaust system faulty	Replace
	Valve timing incorrect	Adjust (*)
	Faulty valve springs	Replace (*)
	Valve seats leaking	Reface seats (*)
	Intake couplings or intake system leaking	Replace
	Clutch slipping	Replace the clutch discs or springs (*)
	Motor oil not to spec.	Use motor oil conforming to spec.
	Air cleaner dirty	Replace
	Fuel pump faulty	Replace
	Fuel pressure too low	Replace the fuel pressure regulator or check the pump
	Injectors dirty	Replace
Piston rings worn	Replace (*)	
See the subsections entitled [The engine produces an excessive amount of exhaust fumes (blue smoke)] and (The clutch slips) for other possible causes		
The engine overheats	Insufficient coolant in the cooling system, system leaking	Top up with coolant, subject the system to a pressure test
	Coolant not to specification	Use coolant conforming to specification
	Radiators dirty or coolant pipes clogged	Clean
	Air in the cooling system	Bleed
	Cooling fan motors faulty	Repair or replace
	Coolant thermal switch faulty	Replace
	Thermal expansion valve faulty (locked in closed position)	Replace
	Coolant pump or coolant pump control drive faulty	Replace (*)
	Insufficient engine oil in the system	Top up with motor oil
	Oil pump or oil pump control faulty, or oil circuit clogged	Replace or clean (*)
	Motor oil not to spec.	Use motor oil conforming to spec.
	Intake couplings or intake system leaking	Replace
	Injectors faulty	Replace
Head gaskets faulty	Replace (*)	
The engine temperature stays too low	Thermal expansion valve faulty (locked in open position)	Replace
The engine produces excessive exhaust fumes (blue smoke)	Clutch diaphragm leaking	Replace (*)
	Valve stem gaskets worn	Replace (*)
	Valve stems or valve guides worn	Replace (*)
	Signs of scratches or scoring on the cylinder walls	Replace (*)
	Piston rings or cylinders worn	Replace (*)
	Head gasket leaking	Replace (*)
The engine vibrates	Engine fastening loose	Tighten
	Bearing or bearing housing worn	Replace
	Countershaft timing incorrect	Adjust (*)
Engine oil pressure too low ("oil" LED comes on)	Insufficient oil in the system	Top up with motor oil
	Oil not to spec.	Replace
	Oil pressure sensor faulty	Replace (*)
	Oil pressure adjusting valve faulty (the adjusting valve remains open)	Clean or replace (*)
	Oil pump control faulty	Replace (*)
	Oil pump worn	Replace (*)

Follow ►

Follow ►

DEFECT	SYMPTOM AND POSSIBLE CAUSES	REMEDY
The engine runs too noisily	The noise seems to be coming from the timing system	
	Chain tightener shoe worn	Replace (*)
	Excessive valve clearance	Adjust (*)
	Valve springs exhausted or broken	Replace (*)
	Bucket-type tappets or camshaft worn	Replace (*)
	Timing chain worn	Replace (*)
	Timing gears worn	Replace (*)
	Timing chain tightener faulty	Replace (*)
	The noise seems to be coming from the piston	
	Piston or cylinder worn	Replace (*)
	Gudgeon pin or connecting rod worn	Replace (*)
	Piston rings or grooves worn or broken	Replace (*)
	The noise seems to be coming from the clutch or clutch casing	
	Clutch discs worn	Replace (*)
	Clutch housing worn	Replace (*)
	Flexible couplings on clutch housing have excessive play	Replace (*)
	Noise with clutch engaged – clutch bearings worn	Replace (*)
	Primary transmission worn or broken	Replace (*)
	The noise seems to be coming from the flywheel casing	
	Timing gears worn or broken	Replace (*)
	The noise seems to be coming from the crank gear	
	Connecting rod bearings worn	Replace (*)
	Driving shaft bushes or countershaft bearings worn	Replace (*)
	The noise seems to be coming from the gearshift	
	Gears or propeller shafts worn or broken	Replace (*)
	Primary gear unit worn	Replace (*)
	Gearshift bearings worn	Replace (*)
	The noise is heard when the engine is started	
	Freewheel gear, gear or housing worn or faulty	Replace (*)
	Double gear or intermediate gear of the starter motor worn	Replace (*)
Starter motor toothing broken	Replace (*)	
The clutch “slips”	Clutch discs worn or distorted	Replace (*)
	Clutch springs exhausted	Replace (*)
	Support plate worn or distorted	Replace (*)
	Motor oil not to spec.	Use motor oil conforming to spec.
	Clutch control hydraulic system faulty	Replace
The clutch does not “disengage”	Control fluid tank level	Check
	Motor oil not to spec.	Use motor oil conforming to spec.
	Clutch discs stuck together	Clean or replace (*)
	Clutch discs or support plate distorted	Replace (*)
	Clutch control hydraulic system faulty	Replace
	Clutch housing worn	Replace (*)
The clutch sticks during engagement	Clutch discs worn or distorted	Replace (*)
	Clutch disc guide grooves inside clutch housing worn	Replace the housing clutch (*)
	Smooth disc guide grooves in clutch disc hub worn	Replace the disc hub (*)
	Thrust-bearing surfaces of the clutch housing or support plate worn	Replace (*)
Gears cannot be engaged or are difficult to engage	Engagement teeth of speed gears worn	Replace (*)
	Propeller shafts worn	Replace (*)
	Selector shaft gearshift mechanism faulty	Repair or replace (*)
	The gearshift forks are worn or distorted	Replace (*)
	See the subsection entitled (The clutch does not “disengage”) for other possible causes	

Follow ►

Follow ►

DEFECT	SYMPTOM AND POSSIBLE CAUSES	REMEDY
The gears disengage when the vehicle is started or whilst accelerating hard	Gearshift gears worn	Replace (*)
	The gearshift forks are worn or distorted	Replace (*)
	The positioning springs are exhausted or broken	Replace (*)
	Gearchanging lacks coordination or is incomplete; the gearshift lever is distorted or adjusted incorrectly	When shifting up or down, always press the gearshift lever pedal down all the way; replace the gearshift lever (*)
Spark plugs overheated, burnt out or dirty	Spark plugs not to spec	Replace
	Spark plugs loose	Tighten
	Intake couplings or intake system leaking	Replace
	Fuel supply system faulty	Repair or replace
The battery alternator is not charged or is charged incorrectly	Battery faulty	Change the battery
	Voltage regulator faulty	Replace
	Break in current, short-circuit or earthing of alternator windings	Replace
	Break in cables or cables short-circuited, connections loose	Repair, change or tighten

8.1.2 ELECTRIC SYSTEM

DEFECT	SYMPTOM AND POSSIBLE CAUSES	REMEDY
Spark plugs becomes dirty immediately with carbon deposits	Motor oil level incorrect	Check
	Unsuitable fuel	Use the prescribed fuel
	Air cleaner dirty	Clean
Spark plugs gets dirty too quickly	Motor oil level incorrect	Check
	Piston segments worn	Replace (*)
	Piston or cylinder worn	Replace (*)
Spark plugs electrodes overheated or burnt	The engine overheats	Adjust
	Spark plug loose	Tighten
Alternator does not charge	Connection terminals interrupted, in short circuit or loose	Repair, change or tighten
	Alternator coils in short circuit, earthed or interrupted	Replace
	Voltage regulator in short circuit or defective	Replace
The alternator does charge but the current intensity is lower than the prescribed value	The terminals are subject to short circuit, interruption or excessive separation	Repair or tighten
	Alternator stator coils earthed or interrupted	Replace
	Voltage regulator faulty	Replace
	Battery faulty	Replace
Alternator charges too much	Short circuit inside battery	Repair or replace
	Voltage regulator damaged or defective	Replace
	Unstable earth of voltage regulator	Replace
Charge not constant	Terminal insulation worn due to vibrations, with consequent temporary short circuits	Repair or replace
	Internal generator short circuits	Replace (*)
	Voltage regulator faulty	Replace

8.1.3 BATTERY

DEFECT	SYMPTOM AND POSSIBLE CAUSES	REMEDY
Battery runs down too quickly	Recharging system defective	Check the alternator, the regulator/rectifier, the circuit connections and carry out operations necessary to restore correct recharge
	Battery elements have lost much active potential consequent on excessive charge	Change the battery and repair charging system
	Presence of short circuits inside battery owing to excessive accumulation of sediments	Change the battery
	Old battery	Change the battery
Battery polarity inverted	Battery has been incorrectly connected to the system	Change the battery and make sure new one is connected properly

8.1.4 BRAKES

DEFECT	SYMPTOM AND POSSIBLE CAUSES	REMEDY
Poor braking power	Brake fluid leakage from hydraulic system	Repair or replace
	Brake pads worn	Change pads
	Contact surfaces of pads soiled by oil, grease or brake fluid	Change pads
	Brake discs worn	Change disc
	Air in hydraulic circuit	Bleed the circuit
	Brake discs dirty with oil, grease or brake fluid	Clean
	Foreign matter in brake fluid	Change brake fluid
	Brake pump return hole clogged	Disassemble and clean brake pump
Brakes squeak	Pad contact surfaces hardened	Restore surfaces with sandpaper
	Pads installed backwards	Install correctly
	Wheel bearing damaged	Replace
	Front or rear wheel pin loose	Tighten to prescribed driving torque
	Brake pads worn	Replace
Excessive stroke of brake lever	Air in hydraulic circuit	Bleed the circuit
	Insufficient brake fluid	Replace
	Unsuitable brake fluid	Replace
	Brake caliper pins locked	Disassemble and clean
Brake fluid leakage	Insufficient tightening of connection fittings	Tighten to prescribed driving torque
	Cracked pipes	Replace
	Pumping element and/or body worn	Change the pumping element and/or body

8.1.5 CHASSIS

DEFECT	SYMPTOM AND POSSIBLE CAUSES	REMEDY
Hard steering	Steering adjustment ring nut too tight	Adjust
	Steering bearings broken	Replace
	Steering axis deformed	Replace
	Insufficient front tyre pressure	Adjust
	Steering shock absorber stiff	Replace
Steering not fluid	Steering bearings damaged	Replace
Handlebar oscillates	Fork tube adjustment incorrect	Adjust
	Fork deformed	Replace
	Front wheel pin deformed or tyre deformed	Replace
	Front/rear wheel not balanced	Balance
Rear wheel oscillates	Wheel rim deformed	Replace
	Wheel bearings worn	Replace
	Tyre defective or unsuitable type	Replace
	Wheel pin nut loose	Tighten
	Fork oil unsuitable	Replace
Fork too soft	Adjustments incorrect	Adjust
	Fork oil unsuitable (viscosity too low)	Replace
	Springs weakened	Replace
	Fork oil insufficient	Top up
	Fork oil exhausted	Replace
Fork too rigid	Adjustments incorrect	Adjust
	Fork oil too viscous	Replace
	Too much oil in fork	Remove excess oil
Noisy fork	Fork oil insufficient	Top up
	Suspension coupling screws and nuts loose	Tighten
Rear wheel oscillates	Wheel rim deformed	Replace
	Wheel bearings worn	Replace
	Tyre defective or unsuitable type	Replace
	Fork bearings worn	Replace
	Suspension screws and nuts loose	Replace
	Rear brake fastening nut loose	Tighten
	Rear fork pin fastening ring loose	Tighten
Rear suspension too soft	Shock absorber spring weakened	Replace
	Adjusting devices incorrectly adjusted	Adjust
	Oil leakage from shock absorber	Replace
	Shock absorber leaking nitrogen	Replace
Rear suspension too rigid	Adjusting devices incorrectly adjusted	Adjust
	Shock absorber pin deformed	Replace
	Fork deformed	Replace
	Fork bearings worn	Replace
	Suspension roller bearings worn	Replace
Rear suspension noisy	Suspension screws and nuts loose	Tighten
	Fork bearings worn	Replace
	Suspension roller bearings worn	Replace

8.2 RUN, FASTENING, WIRING, CABLES AND PIPES

8.2.1 FRONT BRAKE PIPES

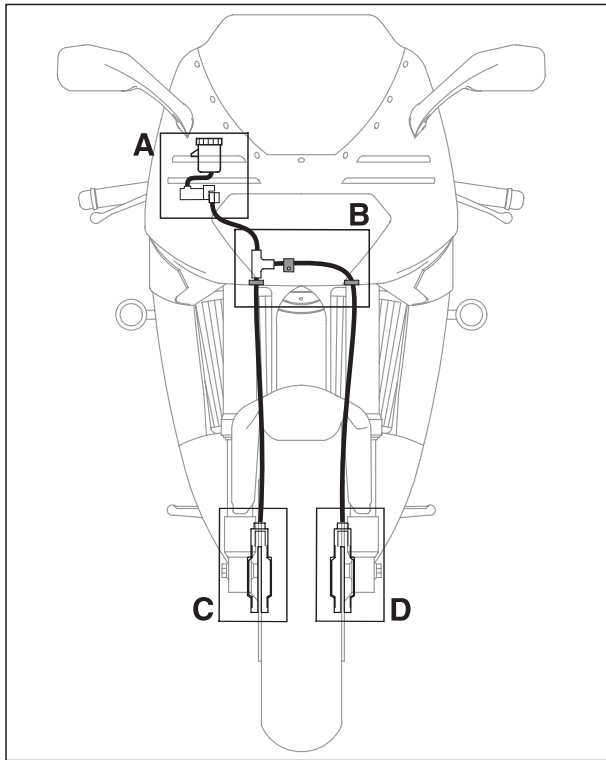

8.2.2 REAR BRAKE PIPES

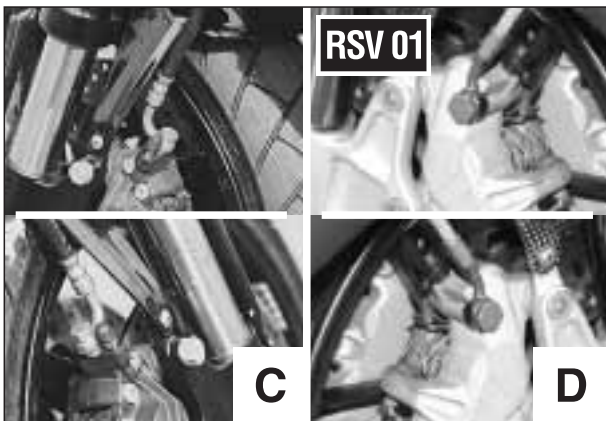
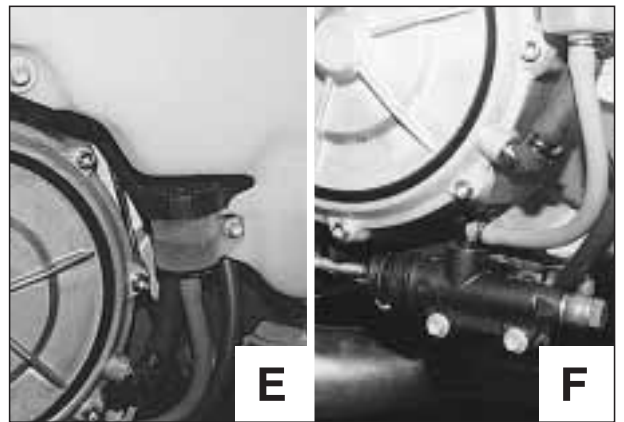
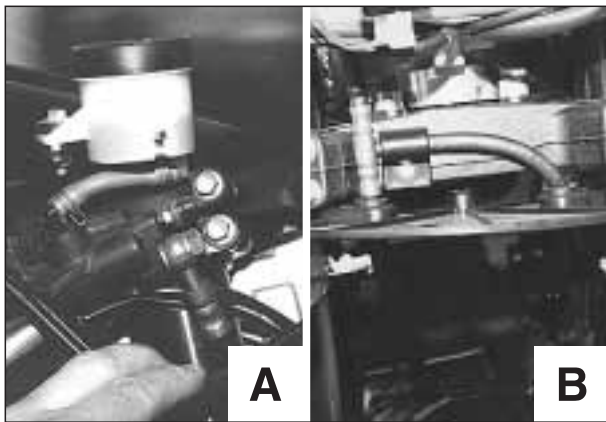
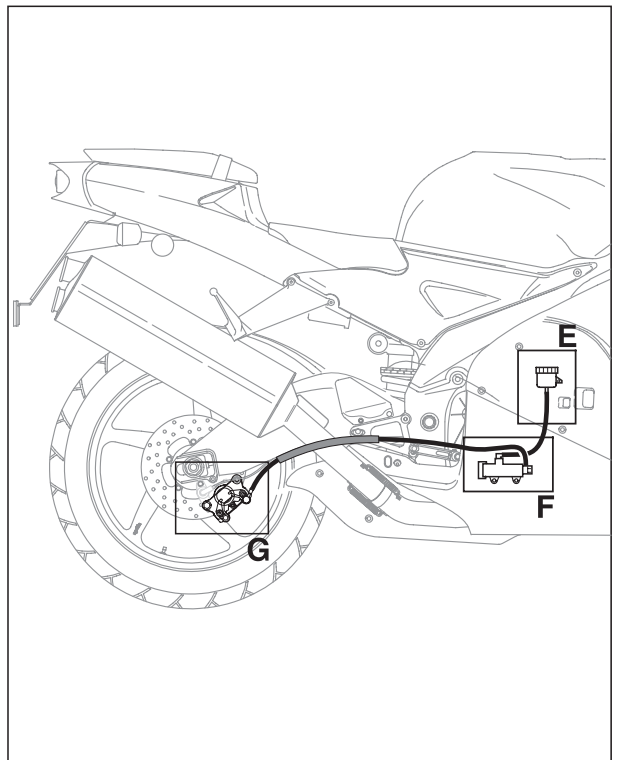

8.2.3 FUEL SYSTEM PIPES

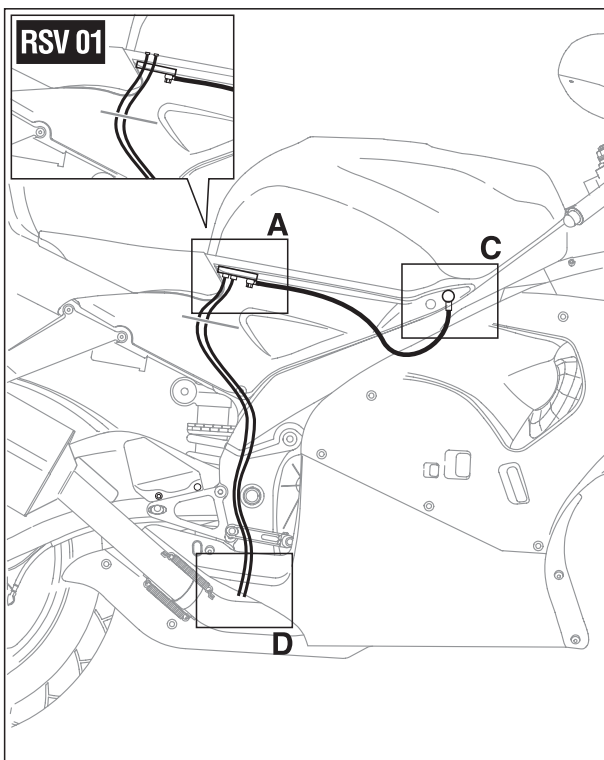
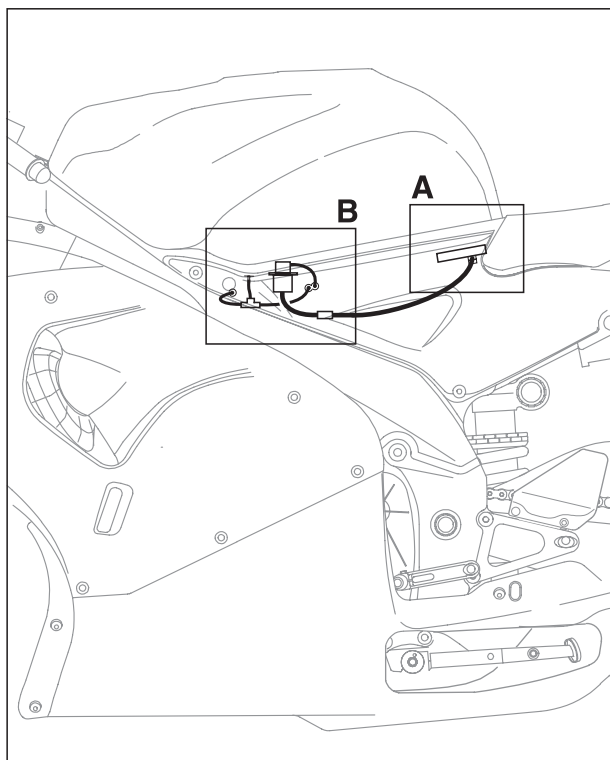

8.2.4 CLUTCH CONTROL PIPE

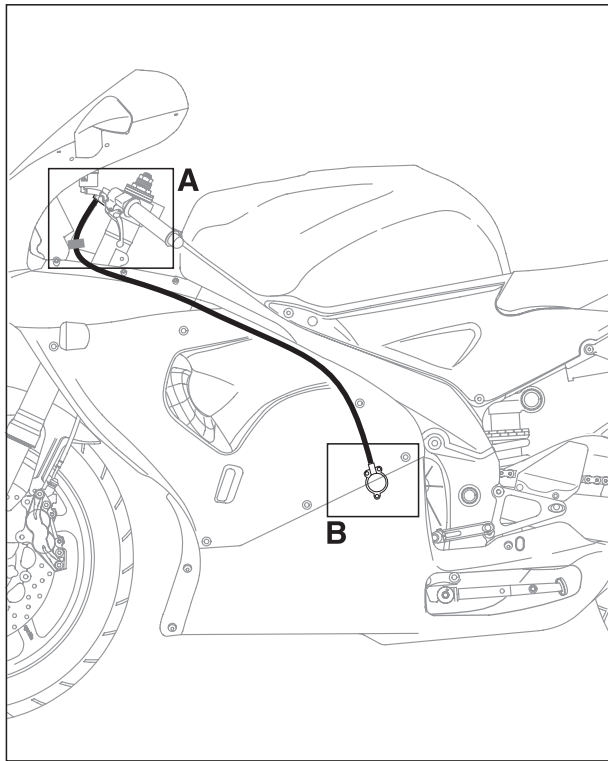

8.2.5 PPC DEVICE PRESSURE PIPES

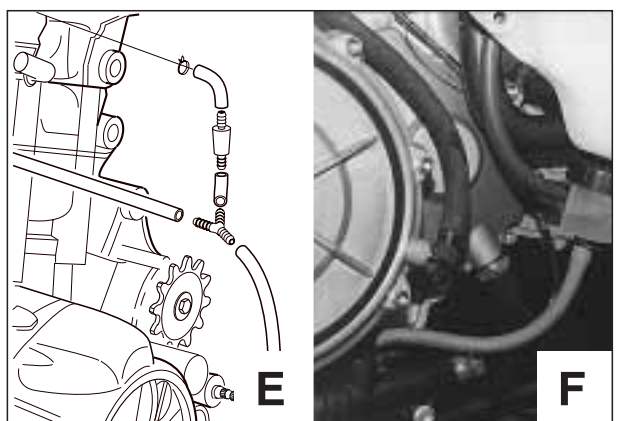
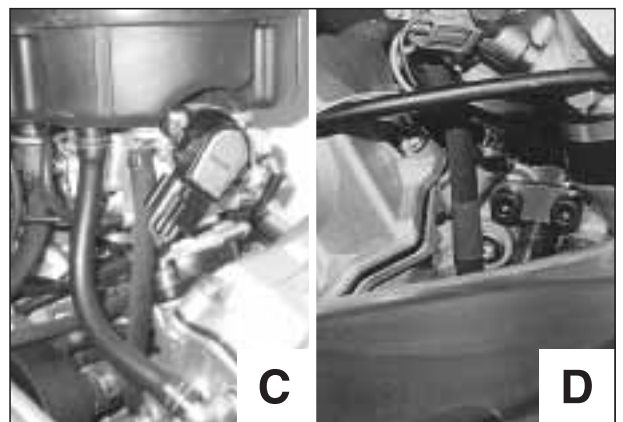
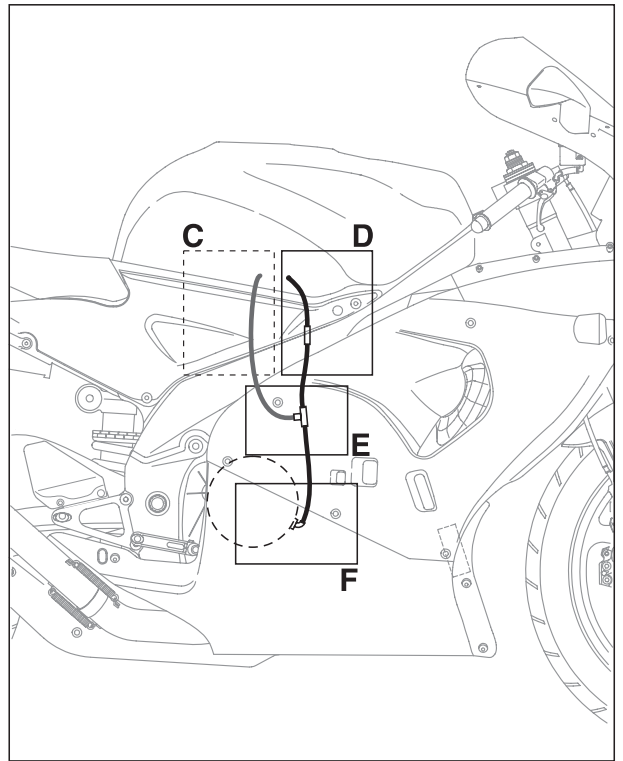

8.2.6 COOLING SYSTEM PIPES

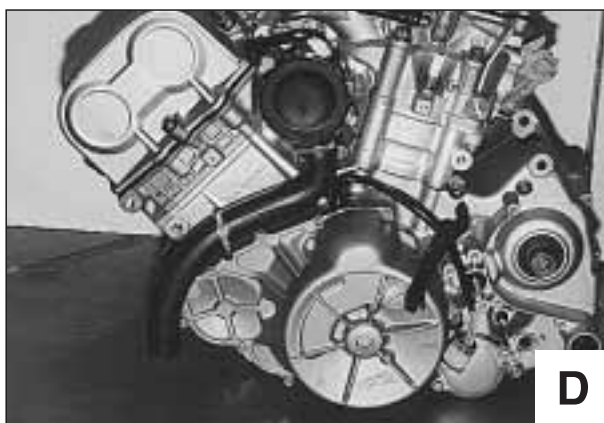
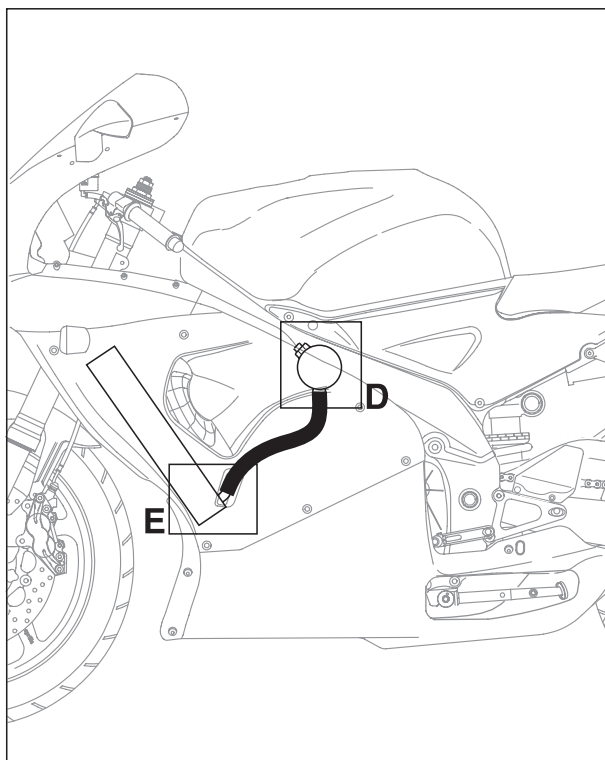
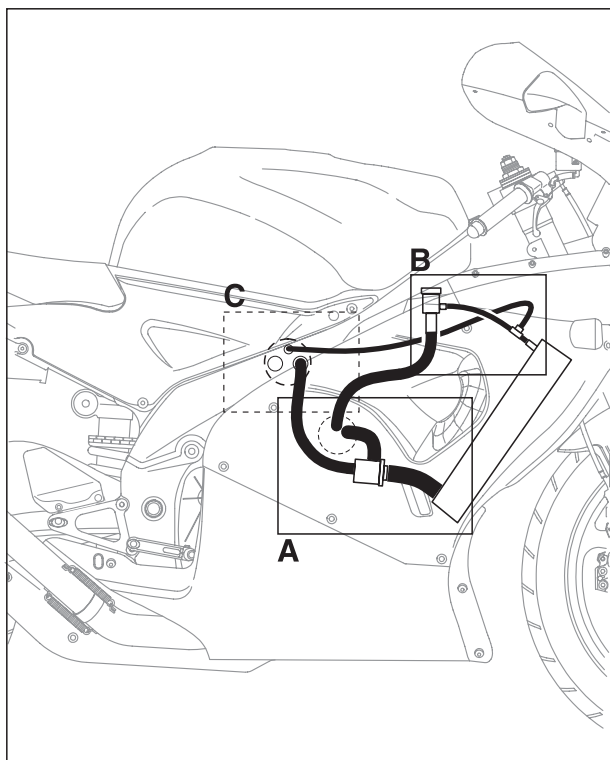

Follow ▶

Follow ►

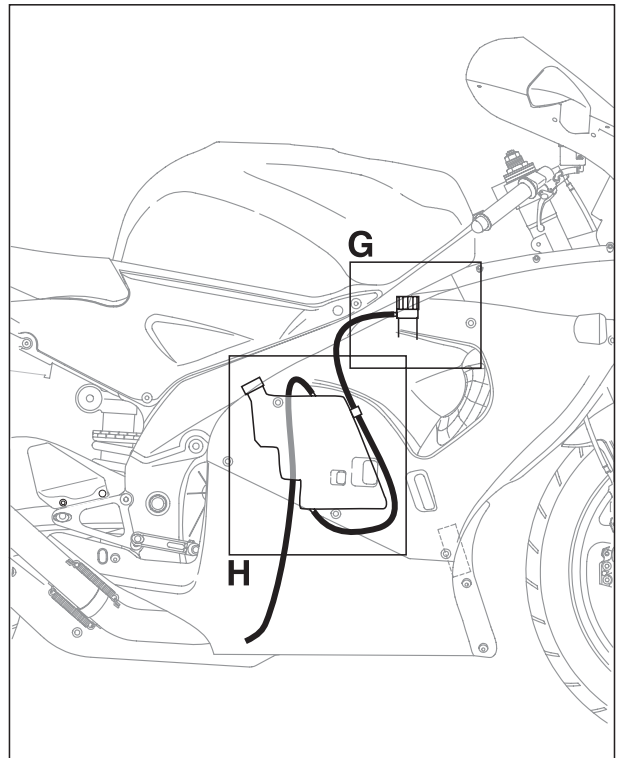
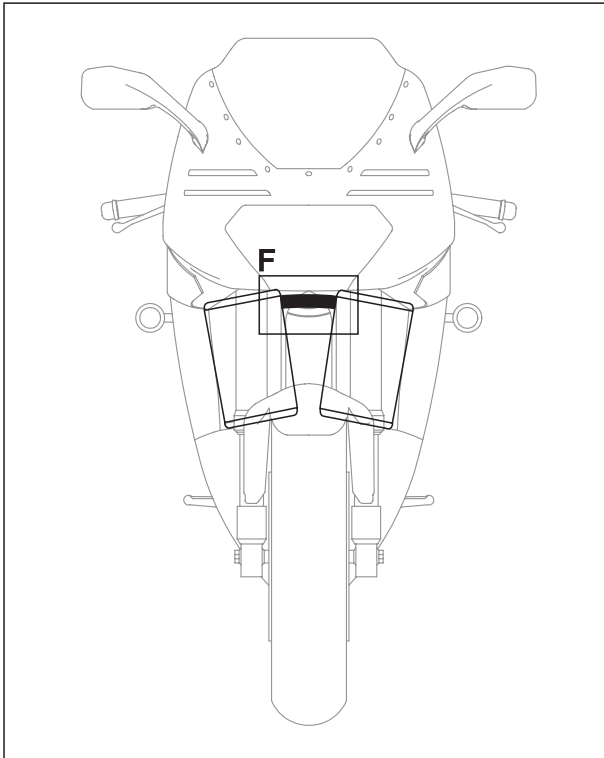

8.2.7 ENGINE OIL PIPES

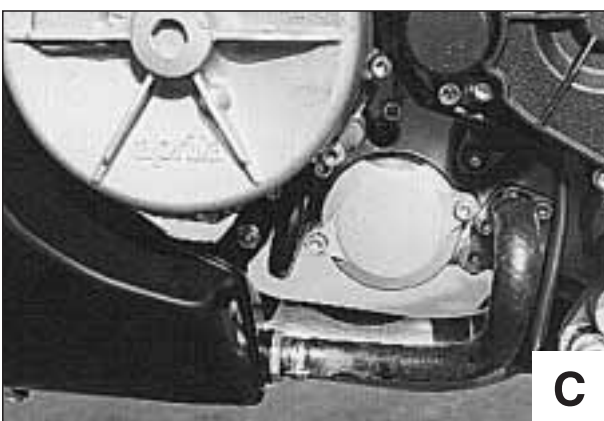
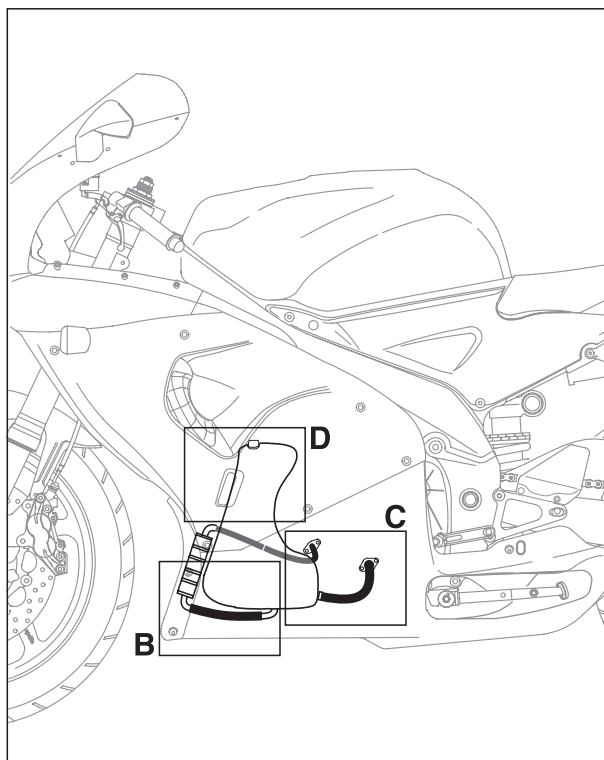
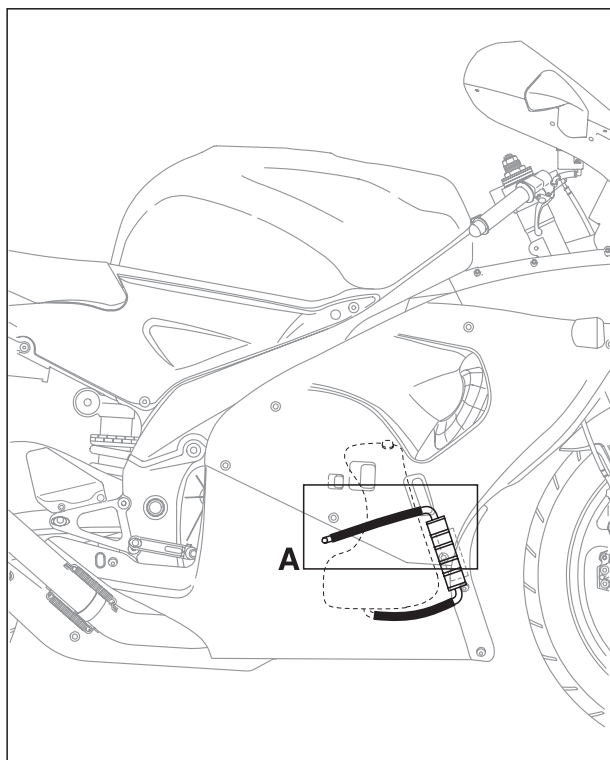

8.2.8 BREATHER AND IMPURITY DRAINAGE PIPES

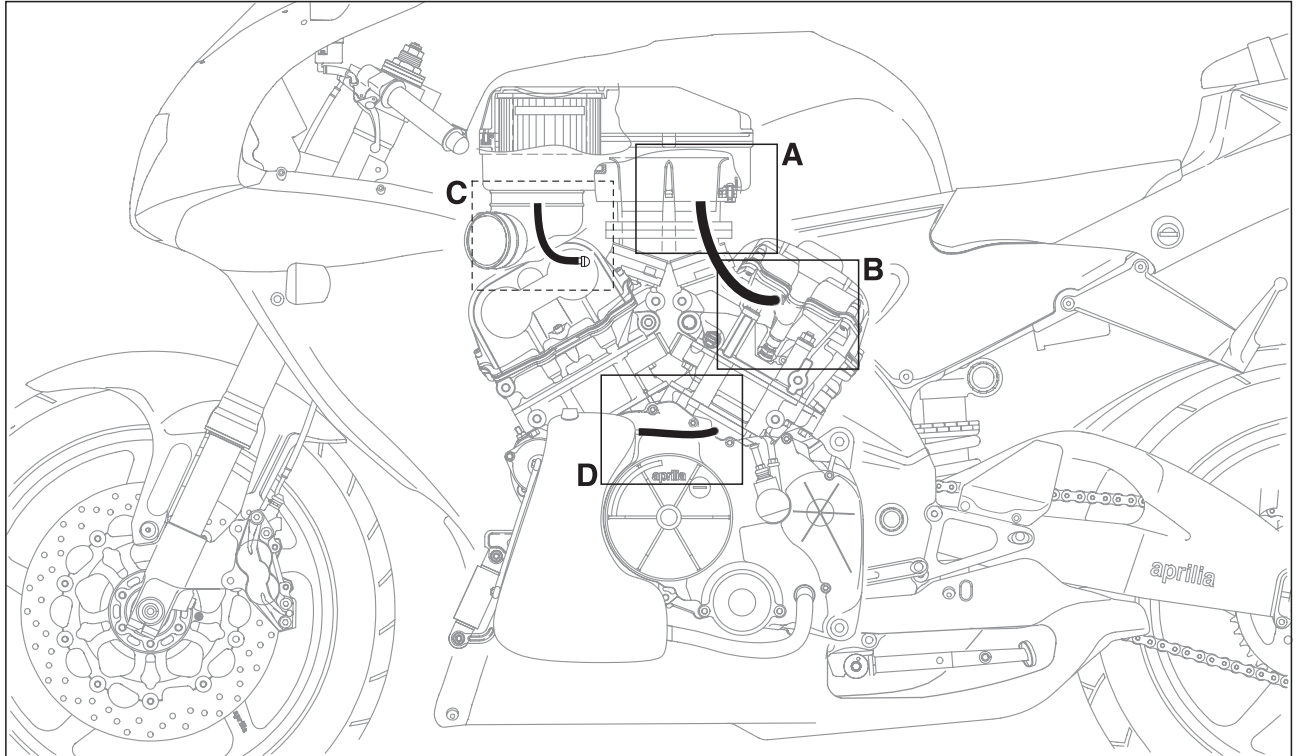

8.2.9 ACCELERATOR CONTROL CABLES

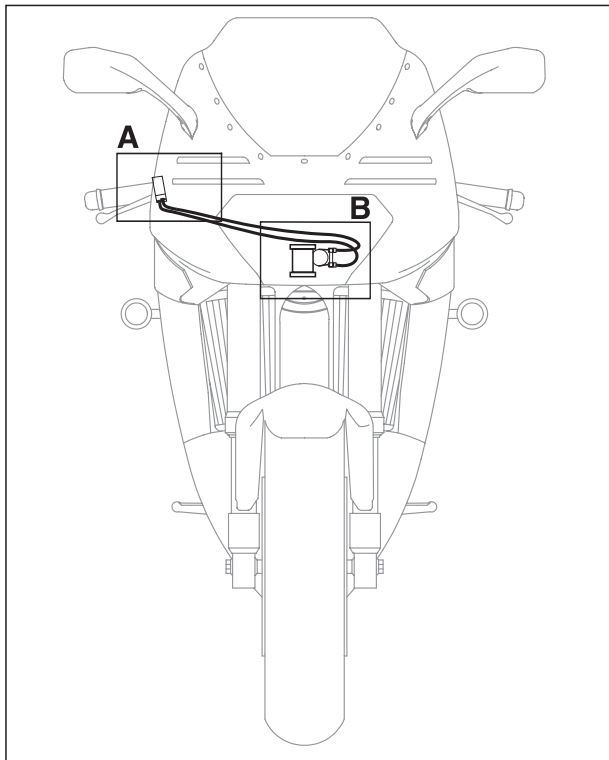

8.2.10 COLD START CABLE

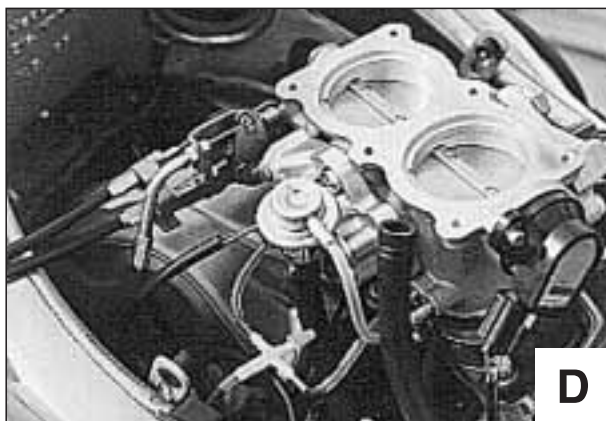
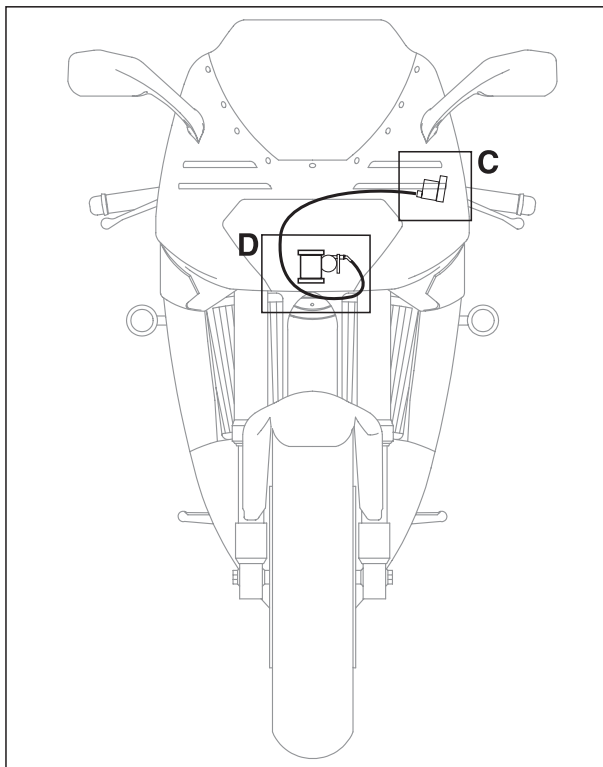

8.2.11 ELECTRIC CABLES

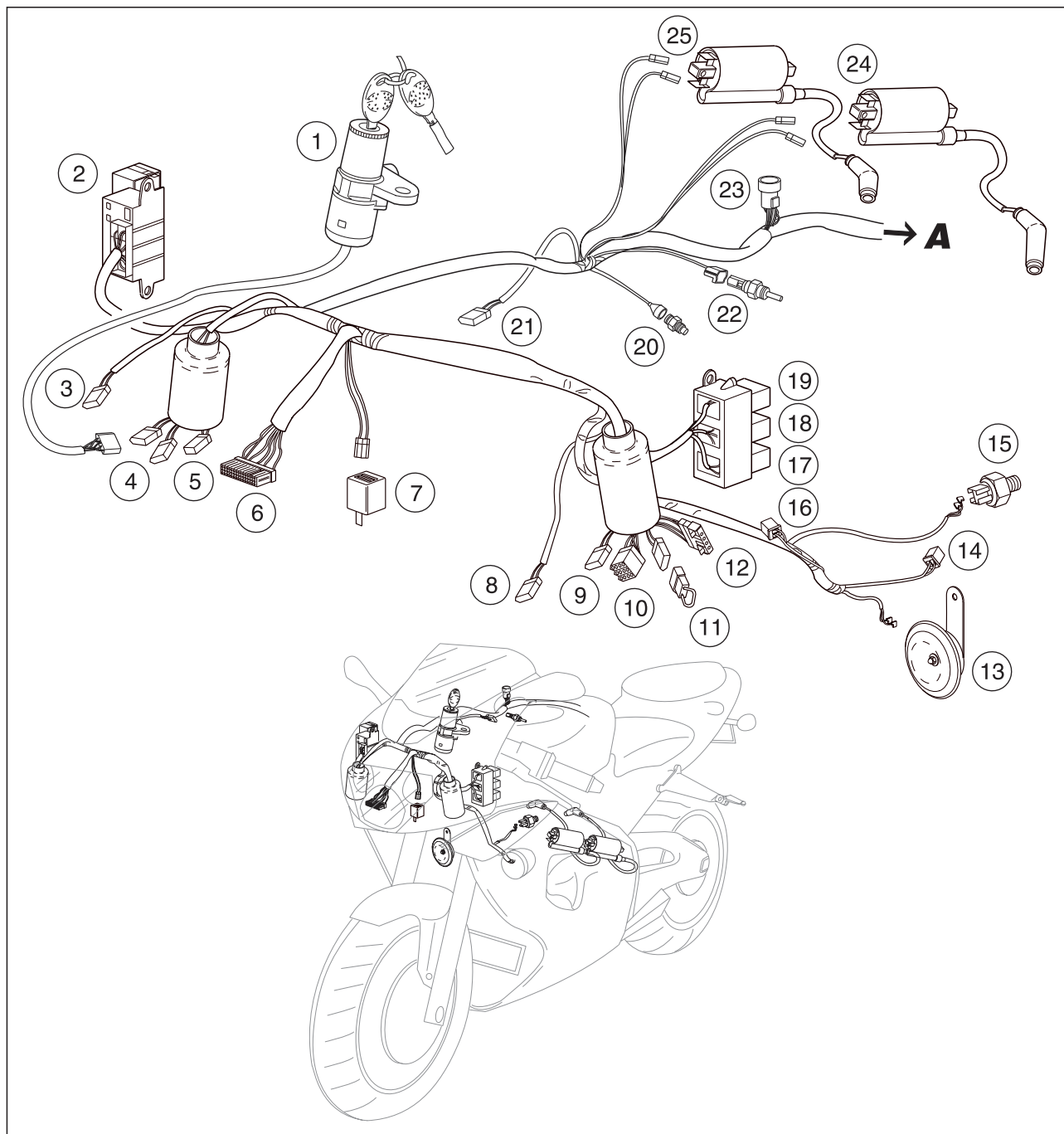

Key

- | | |
|---|------------------------------------|
| 1) Ignition switch | 14) Left electrofan connector |
| 2) Secondary fuse box | 15) Thermal switch |
| 3) Front right indicator connector | 16) Right electrofan connector |
| 4) Stop light switch connector on front brake control lever | 17) Electric fan relay |
| 5) Right dip switch connector | 18) High beam relay |
| 6) Dashboard connector | 19) Dipped beam relay |
| 7) Blinking | 20) Engine oil pressure sensor |
| 8) Front left indicator connector | 21) Side stand switch connector |
| 9) Clutch control lever switch connector | 22) Coolant temperature thermistor |
| 10) Left dip switch connector | 23) Generator/pick-up connector |
| 11) Lights diode/LAP | 24) Rear cylinder coil "1" |
| 12) Headlight connector | 25) Rear cylinder coil "2" |
| 13) Horn | |

Follow ►

Follow ►

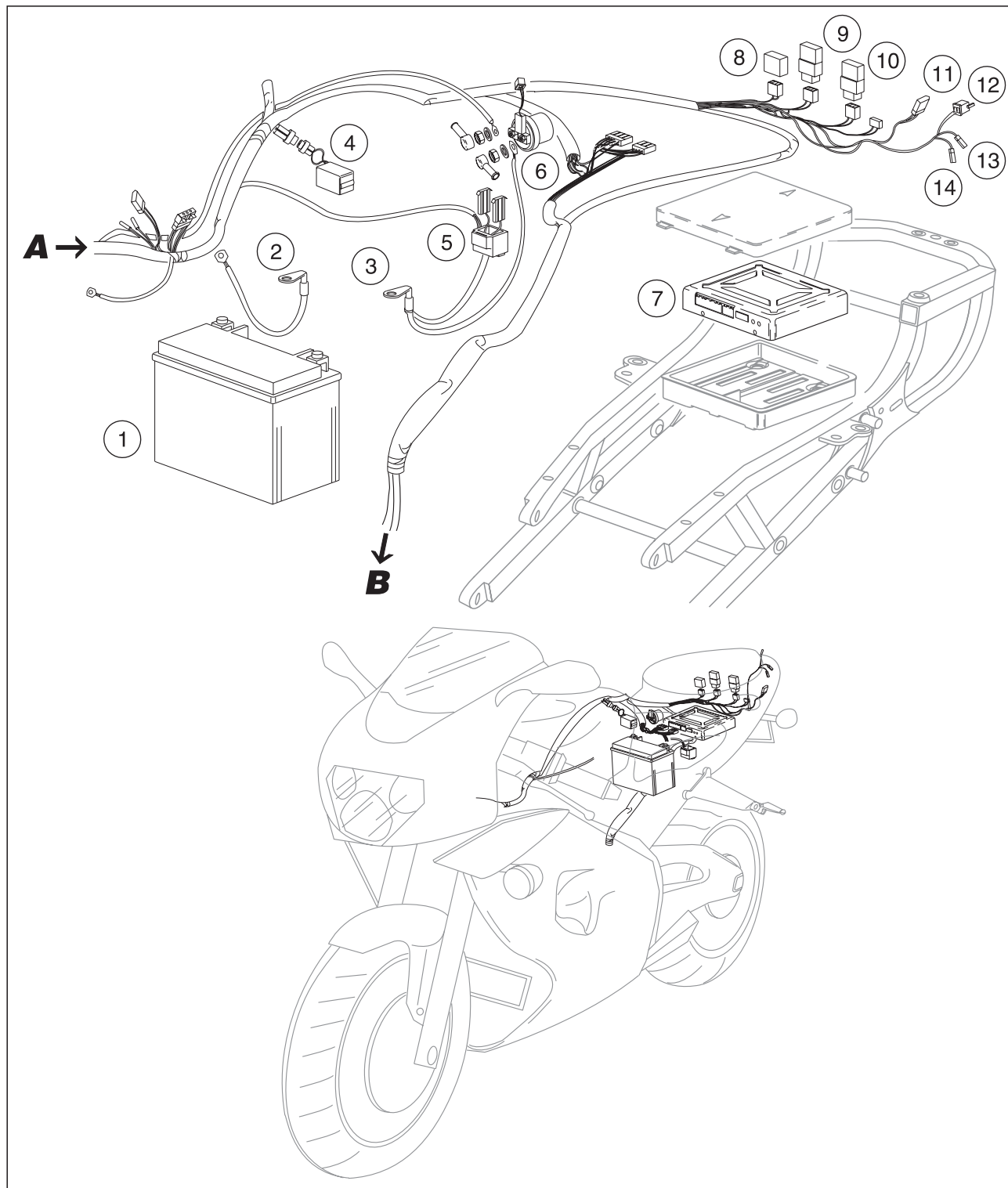

Key

- | | |
|------------------------|---|
| 1) Battery | 8) Diode module |
| 2) Battery earth cable | 9) Fuel pump relay |
| 3) Supply cable | 10) Engine stop relay |
| 4) Fall sensor | 11) Rear light connector |
| 5) Main fuses | 12) Arrangement for the installation of the anti-theft device |
| 6) Start relay | 13) Rear right indicator connector |
| 7) Electronic unit | 14) Rear left indicator connector |

Follow ►

Follow ►

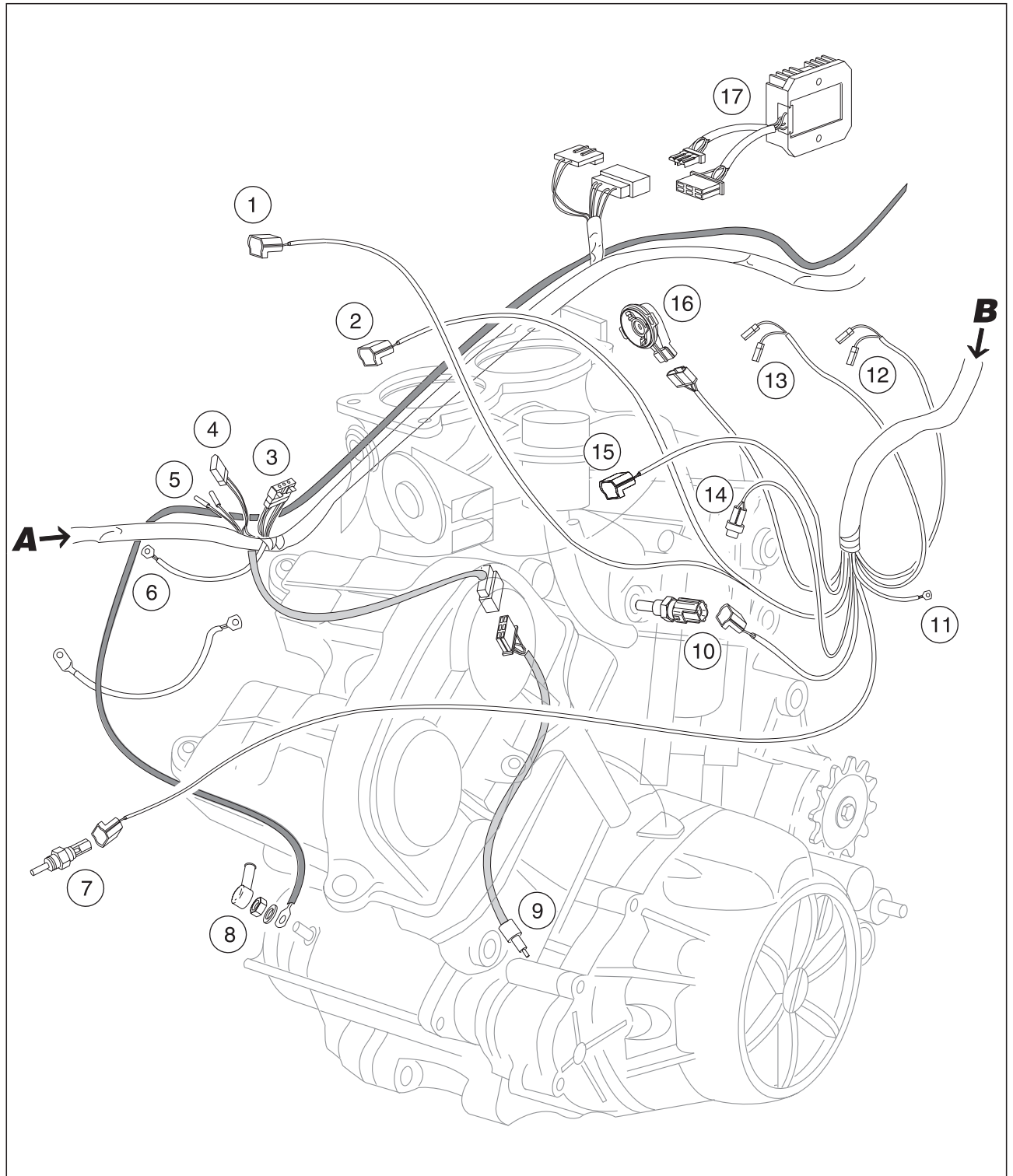

Key

- | | |
|---|--|
| 1) Intake pressure sensor connector | 10) Coolant temperature thermistor |
| 2) Right injector connector | 11) "Neutral" gearbox switch |
| 3) Speed sensor connector | 12) Front cylinder "1" coil connector |
| 4) Fuel pump connector | 13) Front cylinder "2" coil connector |
| 5) TEST connectors | 14) Camshaft position sensor connector |
| 6) Engine earth cable | 15) Left injector connector |
| 7) Air thermistor | 16) Throttle valve potentiometer |
| 8) Starter | 17) Voltage regulator |
| 9) Stoplight switch on the rear brake control lever | |

Follow ►

Follow ▶

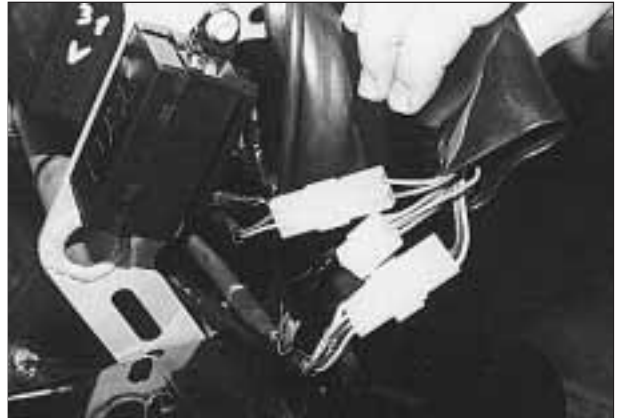
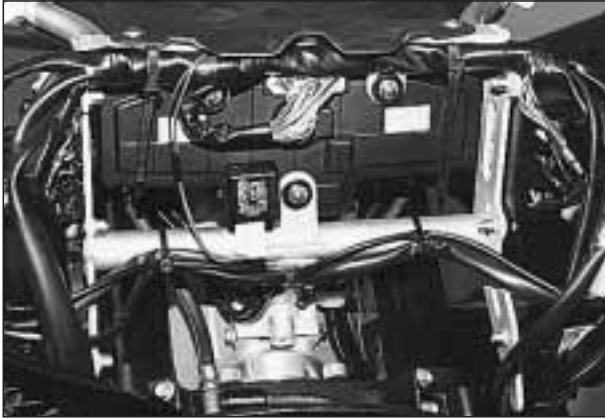

Follow ▶

Follow ►

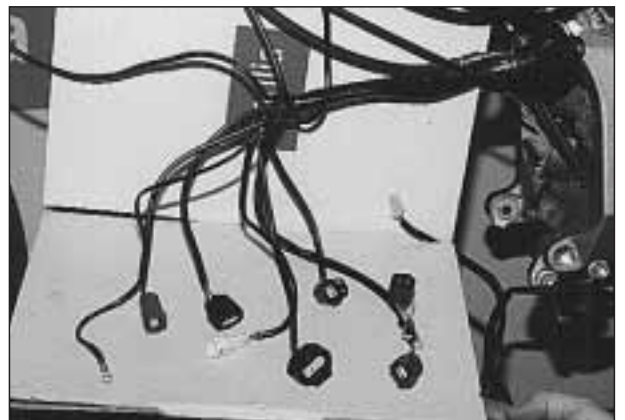
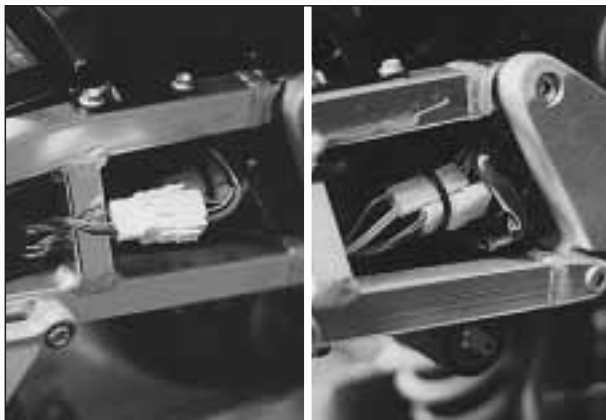

8.3 CHECKING THE ELECTRICAL SYSTEM

See 6.2 (ELECTRIC COMPONENTS LAYOUT) and 8.2.11 (ELECTRIC CABLES) for the location of the electric components.

8.3.1 SPARK PLUGS (no spark)

First check:

- Check the 15 A secondary fuses.
- Check the spark plugs.

Second check:

- Check the main 30 A fuses.
- See 6.4.4 (CHECKING THE IGNITION COILS).

Third check:

- See 6.4.5 (CHECKING THE PICK-UP).

8.3.2 BATTERY RECHARGING PROBLEMS

- See:

- 6.3.1 (CHECKING THE RECHARGING VOLTAGE).
- 6.3.2 (CHECKING THE ALTERNATOR LOADLESS OPERATION).
- 6.3.3 (CHECKING THE ALTERNATOR CONTINUITY).
- 6.3.4 (CHECKING THE VOLTAGE REGULATOR).
- 6.11.3 (CHECKING THE BATTERY).

8.3.3 IGNITION AND/OR STARTING PROBLEMS

Check the diagnostics system to be found in the vehicle, see 6.4.2 [TROUBLESHOOTING (IF THE ENGINE DOES NOT START)].

- Also see:

- 6.4.4 CHECKING THE IGNITION COILS.
- 6.4.5 (CHECKING THE PICK-UP).
- 6.4.6 (CHECKING THE CAMSHAFT POSITION SENSOR).
- 6.4.7 (CHECKING THE FALL SENSOR).
- 6.4.8 (CHECKING THE COOLANT THERMISTOR OPERATION).
- 6.4.9 (CHECKING THE AIR THERMISTOR OPERATION).
- 6.4.10 (CHECKING THE THROTTLE VALVE POTENTIOMETER).
- 6.4.11 (CHECKING THE INTAKE PRESSURE SENSOR).
- 6.4.12 (CHECKING THE INJECTORS).
- 6.5.2 (CHECKING THE FUEL PUMP).
- 6.5.3 (CHECKING THE FUEL PUMP RELAY).
- 6.5.4 (CHECKING THE ENGINE SHUTOFF RELAY).
- 6.6.2 (STARTING SAFETY OPERATING LOGIC).
- 6.6.3 (CHECKING THE STARTING RELAY).
- 6.6.4 (CHECKING THE SIDE STAND AND THE SAFETY SWITCH).
- 6.6.5 (CHECKING THE DIODE MODULE).
- 6.7 (SWITCHES).
- 6.11.3 (CHECKING THE BATTERY).

8.3.4 AUXILIARY SYSTEM PROBLEMS

- See:

- 6.7 (SWITCHES).
- 6.8.2 (CHECKING THE LIGHTS RELAY).
- 6.8.3 [CHECKING THE LIGHTS / LAP DIODE (multi-function)].
- 6.9.2 (CHECKING THE ELECTROFAN OPERATION).
- 6.9.3 (CHECKING THE THERMAL SWITCH OPERATION).
- 6.9.4 (CHECKING THE ELECTROFAN RELAY).
- 6.10.2 (LOW FUEL WARNING LIGHT).
- 6.10.3 (COOLANT TEMPERATURE DISPLAY).
- 6.10.4 (ENGINE OIL PRESSURE SENSOR).
- 6.10.5 (SPEEDOMETER).
- 6.10.6 (REVOLUTION COUNTER).
- 6.11.3 (CHECKING THE BATTERY).

8.4 TECHNICAL DATA AND SPECIFICATIONS

8.4.1 ENGINE

See 0.4.1 (ENGINE SERVICE AND REPAIR MANUALS) for the technical data and specifications.

8.4.2 THROTTLE BODY COMPONENTS

See 4.8 (THROTTLE BODY) for the technical data and specifications.

8.4.3 SUPPLY SYSTEM

- **RSV 01** Fuel tank material = NYLON.
- Material of pipes entering/leaving the delivery filter (internal $\varnothing = 7.5$ mm – external $\varnothing = 14.5$ mm) = NBR-SF-NBR DIN 73379.
- Material of high-pressure delivery pipe = TEFLON incorporating metal plait and ends featuring eyelet connections.
- Material of low-pressure return pipe (internal $\varnothing = 6$ mm – external $\varnothing = 12$ mm) = NBR-SF-NEOPRENE DIN 73379.

8.4.4 ELECTRIC SYSTEM

- Ignition switch = ZADI Q 933.
- Spark plug caps = NGK VD05EMH, NGK VD05EM.
- Spark plug cap resistance = 5 k Ω .

For further information, see 1.5 (TECHNICAL SPECIFICATIONS) and Sect. 6 (ELECTRIC SYSTEM).

8.4.5 FRONT BRAKING SYSTEM

- Disc material = steel.
- Disc thickness = 5.0 mm (minimum 4.5 mm).
- **RSV 01** Disc thickness = 4.5 mm (minimum 4.0 mm).
- Disc diameter = 320 mm.
- Number of caliper pins = 4 facing each other.
- Diameter of caliper pins = 30 mm (lower) + 34 mm (upper).
- **RSV 01** Diameter of caliper pins (standard) = 34 mm (lower and upper).
- **RSV 01** Diameter of caliper pins (alternative) = 32 mm (lower and upper).
- Pad type = sintered.
- Pad friction material (standard) = TOSHIBA TT 2802.
- Pad friction material (alternative) = FERIT/FERODO ID 450.
- **RSV 01** Pad friction material (alternative) = TOSHIBA TT 2172.
- Pad surface area = 23.68 cm².
- **RSV 01** Pad surface area = 9.90 cm².
- Diameter rubber pipes (standard) = external \varnothing 10 mm – internal \varnothing 3.2 mm.
- Diameter metal plait pipes (standard) = external \varnothing 7 mm – internal \varnothing 3.2 mm.
- Pump diameter (standard) = 16 mm.
- **RSV 01** Pump diameter = 15 mm.

8.4.6 REAR BRAKING SYSTEM

- Disc material = steel.
- Disc thickness = 5 mm (minimum 4.5 mm).
- Disc diameter = 220 mm.
- Number of caliper pins = 2 facing each other.
- Diameter of caliper pins = 32 mm.
- Diameter rubber pipes (standard) = FERIT/FERODO ID 450.

- Pad friction material (alternative) = TOSHIBA TT H38GF FERIT/FERODO ID 450/452/459.
- **RSV 01** Pad friction material (alternative) = TOSHIBA TT H38, TOSHIBA TT 2802.
- Pad surface area = 16 cm².
- Diameter rubber pipes (standard) = external \varnothing 10 mm – internal \varnothing 3.2 mm.
- Diameter metal plait pipes (alternative) = external \varnothing 7 mm – internal \varnothing 3.2 mm.
- Pump diameter = 11 mm.

8.4.7 COOLING SYSTEM

See sect. 5 (COOLING SYSTEM)

- Working pressure = 90 – 120 kPa (0.9 – 1.2 bar).

8.4.8 WHEELS

Rims:

See 1.5 (TECHNICAL SPECIFICATIONS).

Rim eccentricity:

See 7.2.2 (CHECKING THE FRONT WHEEL COMPONENTS).

Wheel pin eccentricity:

See 7.2.2 (CHECKING THE FRONT WHEEL COMPONENTS).

Tyres:

See 1.5 (TECHNICAL SPECIFICATIONS) and 7.4 (TYRES).

8.4.9 FRONT SUSPENSION

See 1.5 (TECHNICAL SPECIFICATIONS), 2.29 (INSPECTING THE FRONT AND REAR SUSPENSION) and 7.8 (FRONT FORK).

8.4.10 REAR SUSPENSION

See 1.5 (TECHNICAL SPECIFICATIONS), 2.31 (INSPECTING THE REAR SUSPENSION (models up to 2001)), 7.9 (REAR FORK) and 7.10 (REAR SUSPENSION).

8.4.11 STEERING

See 2.28 (STEERING) and 7.7 (STEERING).

8.4.12 CAPACITIES - FLUID PROPERTIES

See 1.5 (TECHNICAL SPECIFICATIONS) and 1.6 (LUBRICANT CHART).

8.4.13 STRUCTURE (FRAME / SADDLE SUPPORT / DASHBOARD MOUNT)

- Frame / Saddle support / Dashboard mount material = light alloy.
- Frame weight = kg 9.9.
- Frame torsional stiffness = 6500 Nm/° (650 kgm/°).
- Saddle support weight = kg 2.3.
- Dashboard mount weight = kg 0.750.

For further information, see 1.5 (TECHNICAL SPECIFICATIONS).

8.4.14 EXHAUST SYSTEM

-  Catalytic converter = 200 CPSI Pt/Rh S/1 40g/cf.

NOTES

THIS PAGE HAS BEEN INTENTIONALLY LEFT EMPTY

ANALYTICAL INDEX



ANALYTICAL INDEX

A	Ref.	Page
ABBREVIATIONS	0.7	0-9-00
ACCELERATOR	2.11	2-23-00
ACCELERATOR - (REMOVING THE CONTROL)	7.1.15	7-15-00
AIR CLEANER	2.10	2-22-00
AIR CONVEYORS - (REMOVING THE CASES)	7.1.33	7-26-00
AIR CONVEYORS - (REMOVING THE COVERS)	7.1.31	7-25-00
AIR FILTER - (REMOVING THE CASING)	7.1.7	7-9-00
AIR FILTER CASING - (REMOVAL)	7.1.7	7-9-00
AIR THERMISTOR	6.4.9	6-15-00
ALTERNATOR - (CHECKING THE OPERATION)	6.3.2	6-6-00
ALTERNATOR - (CONTINUITY CHECKING)	6.3.3	6-7-00
ANTIVIBRATION WEIGHT UNIT - (REMOVAL)	7.1.10	7-11-00
B	Ref.	Page
BATTERY	6.11	6-38-00
BATTERY - (CHECK)	6.11.3	6-39-00
BATTERY - (LONG INACTIVITY)	2.4.3	2-15-00
BATTERY - (MAINTENANCE)	2.4	2-14-00
	6.11.2	6-39-00
BATTERY - (RECHARGE)	2.4.2	2-15-00
BATTERY - (REMOVAL)	7.1.8	7-10-00
BATTERY - (RETURN UNDER GUARANTEE)	6.11.4	6-39-00
BATTERY GUARANTEE	6.11.4	6-39-00
BLEEDING THE ENGINE OIL CIRCUIT	3.6.1	3-21-00
BODY	7.1	7-3-00
BOLTS AND NUTS - (TIGHTENING)	2.42	2-65-00
BRAKE AND CLUTCH PIPES	2.39	2-63-00
BRAKE PADS	2.27	2-44-00
BRAKES AND CLUTCH CONTROL - (PIPES)	2.39	2-63-00
BULBS	6.12	6-40-00

C	Ref.	Page
CABLE AND PIPE FASTENING	8.2	8-9-00
CABLE AND PIPE LAYOUT	8.2	8-9-00
CABLE AND PIPE LAYOUT	8.2	8-9-00
CABLE COLOURS	6.1.1	6-3-00
CABLES AND PIPES - (RUN, FASTENING, WIRING)	8.2	8-9-00
CAMSHAFT POSITION SENSOR	6.4.6	6-13-00
CENTER SUPPORT STAND - (POSITIONING THE VEHICLE)	1.8.4	1-22-00
CHAIN, PINION AND SPROCKET - (CHECKING THE WEAR)	2.36.2	2-59-00
CLUTCH	2.44	2-65-00
CLUTCH - (REMOVING THE CONTROL CYLINDER)	3.2.3	3-8-00
CLUTCH - (REMOVING THE CONTROL)	7.1.13	7-13-00
CLUTCH CONTROL - (REMOVAL)	7.1.13	7-13-00
CLUTCH CONTROL CYLINDER - (REMOVAL)	3.2.3	3-8-00
CLUTCH FLUID - (CHANGE)	2.24	2-42-00
CLUTCH FLUID - (CHECKING AND TOPPING UP)	2.19	2-34-00
COLD START - (REMOVING THE CONTROL)	7.1.11	7-11-00
COLD-START CONTROL - (REMOVAL)	7.1.11	7-11-00
CONSULTING THE MANUAL - (GUIDE)	0.2	0-5-00
CONSULTING THE MANUAL - (HOW TO CONSULT THE MANUAL)	0.6.1	0-8-00
CONSUMABLES	1.9	1-23-00
COOLANT - (CHANGING)	2.16	2-29-00
COOLANT - (CHECKING AND TOPPING UP)	2.15	2-28-00
COOLANT - (TEMPERATURE INDICATION)	6.10.3	6-35-00
COOLANT TEMPERATURE - (INDICATION)	6.10.3	6-35-00
COOLANT THERMAL SWITCH - (REMOVAL)	5.4	5-9-00
COOLANT THERMISTORS	6.4.8	6-14-00
COOLANT THERMISTORS - (REMOVAL)	5.5	5-9-00
COOLING ELECTROFAN	6.9	6-30-00
COOLING ELECTROFAN - (REMOVAL)	5.3	5-8-00
COOLING SYSTEM - (DESCRIPTION)	5.1	5-3-00
COOLING SYSTEM - (PIPES)	2.40	2-63-00

COOLING SYSTEM PIPES	2.40	2-63-00	ELECTRIC FAN RELAY	6.9.4	6-32-00
CYLINDER SYNCHRONIZATION	4.8.10	4-26-00	ELECTRICAL CONNECTORS	6.1.2	6-3-00
CYLINDERS - (SYNCHRONIZATION)	4.8.10	4-26-00	ELECTRICAL SYSTEM - (CHECK)	8.3	8-22-00
			ELECTRONIC SYSTEM FAULTS	6.4.3	6-11-00
D	Ref.	Page	ELECTRONIC UNIT	4.7.4	4-12-00
DASHBOARD - (CHANGING BULBS AND WARNING LIGHTS)	6.12.4	6-44-00	ELECTRONIC UNIT - (CONNECTIONS)	6.17	6-48-00
DASHBOARD - (REMOVAL)	7.1.25	7-22-00	ELECTRONIC UNIT - (REMOVAL)	7.1.9	7-10-00
DASHBOARD - (REMOVING THE SUPPORT)	7.1.26	7-23-00	END OF THE REAR PART OF THE FAIRING - (REMOVAL)	7.1.36	7-29-00
DASHBOARD - (SIGNALS THAT MAY BE DISPLAYED)	6.10	6-33-00	ENGINE - (CHECKS TO BE CARRIED OUT AFTER THE REASSEMBLY)	3.6	3-21-00
DASHBOARD /FRONT PART OF THE FAIRING SUPPORT (REMOVAL)	7.1.26	7-23-00	ENGINE - (COMPLETE ASSEMBLY ON THE FRAME)	3.5	3-20-00
DASHBOARD BULBS	6.12.4	6-44-00	ENGINE - (COMPLETE REMOVAL FROM THE FRAME)	3.3	3-10-00
DASHBOARD UPPER PROTECTION MOULDING - (REMOVAL)	7.1.24	7-22-00	ENGINE - (COMPONENTS THAT CAN BE REMOVED WITHOUT REMOVING THE ENGINE FROM THE FRAME)	3.2	3-4-00
DASHBOARD WARNING LIGHTS	6.12.4	6-44-00	ENGINE - (ELIMINATION OF FAILURES IN THE ELECTRONIC SYSTEM)	4.7.6	4-13-00
DIODE MODULE	6.6.5	6-24-00	ENGINE - (MANAGEMENT)	4.7	4-8-00
DIODES - (CHECKING THE MODULES)	6.6.5	6-24-00	ENGINE - (POSITIONING ON THE SUPPORT STAND)	3.3.1	3-19-00
DRIVE - (REMOVING THE CHAIN SHOE)	7.1.54	7-41-00	ENGINE - (SENSORS)	4.7.2	4-9-00
DRIVE - (REMOVING THE PINION)	7.1.53	7-40-00	ENGINE - (TECHNICAL INFORMATION)	3.1	3-3-00
DRIVE CHAIN	2.36	2-58-00	ENGINE MANAGEMENT	4.7	4-8-00
DRIVE CHAIN - (DISASSEMBLY)	7.11	7-111-00	ENGINE NUMBER	1.1.2	1-3-00
DRIVE CHAIN - (REMOVING THE SHOE)	7.1.54	7-41-00	ENGINE OIL - (BLEEDING THE CIRCUIT)	3.6.1	3-21-00
DRIVE CHAIN SHOE - (REMOVAL)	7.1.54	7-41-00	ENGINE OIL - (CHANGING)	2.14	2-26-00
DRIVE PINION - (REMOVAL)	7.1.53	7-40-00	ENGINE OIL - (CHECKING THE LEVEL AND TOPPING UP)	2.13	2-25-00
DRIVE UNIT - (REMOVING THE FINAL DRIVE UNIT)	7.3.2	7-54-00	ENGINE OIL - (CHECKING THE PRESSURE)	3.6.2	3-21-00
DRIVING SHAFT POSITION SENSOR	6.4.5	6-12-00	ENGINE OIL - (PRESSURE SENSOR)	6.10.4	6-35-00
DRIVING TORQUES	3.1.7	3-3-00	ENGINE OIL - (REMOVING THE RADIATOR)	7.1.52	7-40-00
DRIVING TORQUES - (GENERAL SPECIFICATIONS)	1.10.2	1-28-00	ENGINE OIL - (REMOVING THE TANK)	7.1.51	7-39-00
E	Ref.	Page	ENGINE OIL FILTER - (CHANGING)	2.14	2-26-00
ELECTRIC COMPONENTS	2.5	2-16-00	ENGINE OIL PIPES	8.2.7	8-14-00
ELECTRIC COMPONENTS - (LAYOUT)	6.2	6-4-00	ENGINE OIL PRESSURE - (CHECK)	3.6.2	3-21-00
ELECTRIC COMPONENTS LAYOUT	6.2	6-4-00	ENGINE OIL PRESSURE - (SENSOR)	6.10.4	6-35-00
ELECTRIC CONTROLS ON THE LEFT PART OF THE HANDLEBAR - (REMOVAL)	7.1.14	7-14-00	ENGINE OIL PRESSURE SENSOR	6.10.4	6-35-00
ELECTRIC CONTROLS ON THE RIGHT PART OF THE HANDLEBAR - (REMOVAL)	7.1.17	7-17-00	ENGINE OIL RADIATOR - (REMOVAL)	7.1.52	7-40-00
			ENGINE OIL TANK - (REMOVAL)	7.1.51	7-39-00

ENGINE PARTS WHICH CAN BE DISASSEMBLED WITHOUT REMOVING THE ENGINE FROM THE FRAME	3.2	3-4-00	FRONT BRAKE LEVER - (REMOVAL)	7.1.16	7-15-00
ENGINE SENSORS	4.7.2	4-9-00	FRONT BRAKE PADS (models up to 2001) - (CHANGE)	7.5.1	7-70-00
ENGINE STOP RELAY	6.5.4	6-21-00	FRONT BRAKE PADS (RSV01) - (CHANGE)	7.5.2	7-71-00
ENGINE SUPPORT STAND	3.3.1	3-19-00	FRONT BRAKE PUMP - (REMOVAL)	7.5.5	7-72-00
EXHAUST - (REMOVING THE SILENCER)	7.1.49	7-37-00	FRONT DIRECTION INDICATORS - (REMOVAL)	7.1.30	7-24-00
EXHAUST MANIFOLD	2.35	2-57-00	FRONT FORK	7.8	7-87-00
EXHAUST PIPES - (REMOVAL)	3.2.1	3-6-00	FRONT MUDGUARD - (REMOVAL)	7.1.27	7-23-00
EXHAUST SILENCER - (REMOVAL)	7.1.49	7-37-00	FRONT PART OF THE FAIRING - (REMOVAL)	7.1.22	7-21-00
EXPANSION TANK - (REMOVAL)	5.9	5-13-00	FRONT PART OF THE FAIRING - (REMOVING THE SUPPORT)	7.1.26	7-23-00
F	Ref.	Page	FRONT SUPPORT STAND - (POSITIONING THE VEHICLE)	1.8.3	1-21-00
FAILURES - (IF THE ENGINE DOES NOT START)	6.4.2	6-9-00	FRONT SUSPENSION	2.29	2-48-00
FAILURES IN THE ENGINE ELECTRONIC SYSTEM	4.7.6	4-13-00	FRONT WHEEL	2.33	2-56-00
FALL SENSOR	6.4.7	6-13-00		7.2	7-45-00
FASTENING ELEMENTS	1.10	1-27-00	FRONT WHEEL - (REMOVING THE FORK TOGETHER WITH THE WHEEL)	7.7.1	7-83-00
FAULTS - (TROUBLESHOOTING)	8.1	8-3-00	FRONT WHEEL BEARINGS - (DISASSEMBLY)	7.2.9	7-49-00
FILLER - (REMOVAL)	5.7	5-11-00	FUEL - (FUEL TANK FILLER CAP)	7.1.4	7-6-00
FINAL DRIVE UNIT BEARINGS - (DISASSEMBLY)	7.3.15	7-61-00	FUEL - (LOW FUEL WARNING LIGHT)	6.10.2	6-34-00
FORECARRIAGE - (HEIGHT ADJUSTMENT)	2.29.3	2-50-00	FUEL - (PIPES)	2.38	2-63-00
FORK - (ADJUSTMENT)	2.29.2	2-49-00	FUEL - (REMOVING THE DELIVERY FILTER)	4.5	4-6-00
FORK TOGETHER WITH FRONT WHEEL - (REMOVAL)	7.7.1	7-83-00	FUEL - (REMOVING THE ENTIRE FUEL PUMP UNIT)	4.3	4-5-00
FRAME	3.2	3-4-00	FUEL - (REMOVING THE FUEL LEVEL SENSOR)	4.4	4-6-00
FRAME - (COMPLETE ASSEMBLY OF THE ENGINE ON THE FRAME)	3.5	3-20-00	FUEL - (REMOVING THE FUEL SUPPLY PUMP)	4.6	4-7-00
FRAME - (COMPLETE REMOVAL OF THE ENGINE FROM THE FRAME)	3.3	3-10-00	FUEL DELIVERY FILTER - (REMOVAL)	4.5	4-6-00
FRAME - (REMOVAL)	7.1.57	7-43-00	FUEL LEVEL SENSOR - (REMOVAL)	4.4	4-6-00
FRAME NUMBER	1.1.1	1-3-00	FUEL PIPES	2.38	2-63-00
FRONT / REAR DIRECTION INDICATORS	6.12.2	6-43-00	FUEL PUMP	6.5	6-19-00
FRONT BRAKE	7.5	7-69-00	FUEL PUMP RELAY	6.5.3	6-21-00
FRONT BRAKE - (REMOVING THE CONTROL)	7.1.16	7-15-00	FUEL PUMP SYSTEM	6.5	6-19-00
FRONT BRAKE - (REMOVING THE PUMP)	7.5.5	7-72-00	FUEL SUPPLY - (REMOVING THE FUEL PUMP)	4.6	4-7-00
FRONT BRAKE FLUID - (CHANGING)	2.22	2-40-00	FUEL SUPPLY PUMP - (REMOVAL)	4.6	4-7-00
FRONT BRAKE FLUID - (CHECKING AND TOPPING UP)	2.17	2-31-00	FUEL SUPPLY PUMP - (REMOVING THE WHOLE UNIT)	4.3	4-5-00
			FUEL TANK	4.1	4-3-00

FUEL TANK - (COMPLETE REMOVAL)	7.1.6	7-8-00
FUEL TANK - (EMPTYING)	2.9	2-20-00
FUEL TANK - (PARTIAL REMOVAL)	7.1.5	7-7-00
FUEL TANK - (RAISING)	2.8	2-20-00
FUEL TANK - (REMOVING THE CAP)	7.1.4	7-6-00
FUEL TANK FILLER CAP - (REMOVAL)	7.1.4	7-6-00
FUSES - (CHANGING)	6.15	6-46-00

G	Ref.	Page
GEAR LEVER - (REMOVAL)	3.2.2	3-7-00
GEARSHIFT - (ADJUSTING THE GEARSHIFT LEVER)	2.25	2-42-00
GEARSHIFT - (REMOVING THE GEARSHIFT LEVER)	3.2.2	3-7-00
GEARSHIFT CONTROL - (REMOVING THE GEARSHIFT LEVER)	3.2.2	3-7-00

H	Ref.	Page
HANDGRIPS - (REMOVAL)	7.1.12	7-12-00
HANDLEBAR HALVES - (REMOVAL)	7.1.20	7-20-00
HEADLIGHT	6.12.1	6-40-00
HEADLIGHT - (REMOVAL)	7.1.23	7-22-00

I	Ref.	Page
IDLING SPEED - (ADJUSTMENT)	2.11.2	2-23-00
IGNITION - (REMOVING THE SWITCH)	7.1.18	7-18-00
IGNITION COILS	6.4.4	6-12-00
IGNITION SWITCH/STEERING LOCK - (REMOVAL)	7.1.18	7-18-00
INDICATORS ON THE DASHBOARD	6.10	6-33-00
INFLATION PRESSURE	2.37.2	2-62-00
INITIALS	0.7	0-9-00
INJECTION - (SYSTEM DIAGRAM)	4.7.3	4-11-00
INJECTORS	6.4.12	6-18-00
INJECTORS - (REMOVAL)	4.8.1	4-14-00
INSTRUCTIONS FOR USE OF FUEL, LUBRICANTS, COOLANT AND OTHER COMPONENTS	1.2	1-4-00
INTAKE PRESSURE	6.4.11	6-17-00
INTAKE PRESSURE SENSOR	6.4.11	6-17-00

J	Ref.	Page
JUMP-STARTING	2.6	2-17-00

K	Ref.	Page
-	-	-

L	Ref.	Page
LIGHT BEAM - (VERTICAL ADJUSTMENT)	6.13	6-45-00
LIGHT BEAM (USA) - (HORIZONTAL ADJUSTMENT)	6.14	6-45-00
LIGHT DIODE / LAP	6.8.3	6-29-00
LIGHT RELAY	6.8.2	6-29-00
LIGHT SYSTEM	6.8	6-28-00
LIGHTS - (SYSTEM)	6.8	6-28-00
LOW FUEL - (WARNING LIGHT)	6.10.2	6-34-00
LOW FUEL WARNING LIGHT	6.10.2	6-34-00
LOWER PART OF THE FAIRING - (REMOVAL)	7.1.34	7-27-00
LUBRICANT CHART	1.6	1-12-00
LUBRICANTS	1.6	1-12-00
LUBRICATION - (POINTS TO BE LUBRICATED)	2.2	2-6-00

M	Ref.	Page
MULTIFUNCTION COMPUTER	2.3	2-8-00

N	Ref.	Page
NUMBER PLATE HOLDER - (REMOVAL)	7.1.42	7-34-00
NUT, BOLT, SCREW TIGHTENING	2.42	2-65-00

O	Ref.	Page
-	-	-

P	Ref.	Page
PASSENGER - (REMOVING THE FOOTREST SUPPORTS)	7.1.44	7-34-00
PASSENGER - (REMOVING THE FOOTREST)	7.1.45	7-35-00
PASSENGER - (REMOVING THE SEAT LOCK)	7.1.39	7-31-00

PASSENGER FOOTREST - (REMOVAL)	7.1.45	7-35-00	REAR FORK	2.30	2-51-00
PASSENGER FOOTREST SUPPORTS - (REMOVAL)	7.1.44	7-34-00		7.9	7-101-00
PASSENGER FOOTRESTS - (REMOVING THE SUPPORTS)	7.1.44	7-34-00	REAR LIGHT	6.12.3	6-43-00
PASSENGER SEAT - (REMOVING THE LOCK)	7.1.39	7-31-00	REAR LIGHT - (REMOVAL)	7.1.37	7-29-00
PASSENGER SEAT - (UNLOCKING/ LOCKING)	7.1.2	7-5-00	REAR MUDGUARD - (REMOVAL)	7.1.43	7-34-00
PASSENGER SEAT LOCK - (REMOVAL)	7.1.39	7-31-00	REAR PART OF THE FAIRING - (REMOVAL)	7.1.38	7-30-00
PERIODIC MAINTENANCE	2.1	2-3-00	REAR SHOCK ABSORBER - (ADJUSTMENT)	2.31.2	2-52-00
PINION, CHAIN AND SPROCKET - (CHECKING THE WEAR)	2.36.2	2-59-00	REAR SUPPORT STAND - (ASSEMBLING PINS)	1.8.1	1-21-00
PIPES AND CABLES - (LAYOUT, FASTENING, WIRING)	8.2	8-9-00	REAR SUPPORT STAND - (POSITIONING THE VEHICLE)	1.8.2	1-21-00
PISTONS	2.45	2-65-00	REAR SUSPENSION	2.31	2-52-00
				7.10	7-107-00
			REAR SUSPENSION (RSV01)	2.32	2-54-00
			REAR SUSPENSION SHOCK ABSORBER (models up to 2001) - (REMOVAL)	7.10.1	7-107-00
			REAR SUSPENSION SHOCK ABSORBER (RSV01) - (REMOVAL)	7.10.2	7-108-00
			REAR WHEEL	2.34	2-57-00
				7.3	7-52-00
			REAR WHEEL BEARINGS - (DISASSEMBLY)	7.3.13	7-59-00
			REAR-VIEW MIRRORS - (REMOVAL)	7.1.21	7-21-00
			RECHARGE - (CHECKING THE SYSTEM)	6.3	6-6-00
			RECHARGE SYSTEM	6.3	6-6-00
			RED LINE - (ADJUSTING THE THRESHOLD)	2.3.4	2-10-00
			RED LINE THRESHOLD	2.3.4	2-10-00
			REFERENCE MANUALS	0.4	0-6-00
			REFITTING THE WHOLE ENGINE ON THE FRAME	3.5	3-20-00
			REMOVING THE WHOLE ENGINE FROM THE FRAME	3.3	3-10-00
			REVOLUTION COUNTER	6.10.6	6-37-00
			RIDER - (REMOVING THE FOOTREST SUPPORTS)	7.1.46	7-35-00
			RIDER - (REMOVING THE FOOTRESTS)	7.1.47	7-36-00
			RIDER FOOTREST SUPPORTS - (REMOVAL)	7.1.46	7-35-00
			RIDER FOOTRESTS - (REMOVING THE SUPPORTS)	7.1.46	7-35-00
			RIDER FOOTRESTS - (REMOVAL)	7.1.47	7-36-00

Q	Ref.	Page
-	-	-

R	Ref.	Page
----------	-------------	-------------

RADIATOR SPOILERS - (REMOVAL)	7.1.35	7-28-00
RADIATORS - (REMOVAL)	5.2	5-7-00
RADIATORS - (REMOVING THE SPOILER)	7.1.35	7-28-00
REAR BRAKE	7.6	7-76-00
REAR BRAKE - (ADJUSTING THE BRAKE LEVER SLACK)	2.26	2-43-00
REAR BRAKE - (ADJUSTING THE BRAKE LEVER)	2.25	2-42-00
REAR BRAKE - (REMOVING THE BRAKE LEVER)	7.1.48	7-36-00
REAR BRAKE - (REMOVING THE DISC)	7.6.3	7-78-00
REAR BRAKE - (REMOVING THE PUMP)	7.6.4	7-79-00
REAR BRAKE DISC - (REMOVAL)	7.6.3	7-78-00
REAR BRAKE FLUID - (CHANGING)	2.23	2-41-00
REAR BRAKE FLUID - (CHECKING AND TOPPING UP)	2.18	2-32-00
REAR BRAKE LEVER - (REMOVAL)	7.1.48	7-36-00
REAR BRAKE PADS - (CHANGING)	7.6.1	7-77-00
REAR BRAKE PUMP - (REMOVAL)	7.6.4	7-79-00
REAR DIRECTION INDICATORS - (REMOVAL)	7.1.40	7-31-00
REAR FAIRING - (REMOVING THE REAR FAIRING REAR END)	7.1.36	7-29-00

RIDER SADDLE - (REMOVAL)	7.1.1	7-5-00
RUNNING-IN	1.3	1-7-00
S		
SADDLE PILLAR LOWER COVER - (REMOVAL)	7.1.41	7-32-00
SADDLE SUPPORT - (REMOVAL)	7.1.56	7-42-00
SAFETY - (MESSAGES)	0.5	0-7-00
SAFETY UPON STARTING THE VEHICLE	6.6	6-22-00
SEALANTS	3.1.4	3-3-00
SERIAL NUMBERS - (POSITION)	1.1	1-3-00
SIDE COVERS - (REMOVAL)	7.1.3	7-6-00
SIDE FAIRINGS - (REMOVAL)	7.1.28	7-24-00
SIDE STAND - (REMOVAL)	7.1.50	7-38-00
SPARE PARTS	1.4	1-7-00
SPARK PLUGS	2.7	2-18-00
SPECIAL TOOLS	1.7	1-14-00
SPEEDOMETER	6.10.5	6-36-00
SPROCKET, CHAIN AND PINION - (CHECKING THE WEAR)	2.36.2	2-59-00
STAND - (CHECKING THE SWITCH)	6.6.4	6-24-00
STAND SWITCH	6.6.4	6-24-00
START - (SAFETY SYSTEM OPERATION)	6.6.2	6-23-00
START - (SAFETY SYSTEM)	6.6	6-22-00
START RELAY	6.6.3	6-23-00
STARTING SAFETY OPERATING LOGIC	6.6.2	6-23-00
STEERING	2.28	2-46-00
	7.7	7-82-00
STEERING - (CHECKING THE BEARING SLACK)	2.28.1	2-46-00
STEERING - (REMOVING THE SHOCK ABSORBER)	7.7.6	7-86-00
STEERING BEARINGS - (CHECKING THE SLACK)	2.28.1	2-46-00
STEERING LOCK - (REMOVING THE SWITCH)	7.1.18	7-18-00
STEERING SHOCK ABSORBER - (REMOVAL)	7.7.6	7-86-00
SUPPORT STANDS	1.7.1	1-14-00
SWITCHES	6.7	6-25-00
SWITCHES - (CHECK)	6.16	6-47-00

SYMBOLS	0.7	0-9-00
T		
TECHNICAL DATA	1.5	1-8-00
TECHNICAL DATA AND SPECIFICATIONS	8.4	8-23-00
TECHNICAL INFORMATION ON THE ENGINE	3.1	3-3-00
TECHNICAL SPECIFICATIONS	1.5	1-8-00
TECHNICAL SPECIFICATIONS	8.4	8-23-00
THERMAL EXPANSION VALVE - (REMOVAL)	5.6	5-10-00
THREE-WAY MANIFOLD - (REMOVAL)	5.8	5-12-00
THROTTLE BODY	4.8	4-14-00
THROTTLE GRIP - (REMOVAL)	7.1.15	7-15-00
THROTTLE VALVE POTENTIOMETER	6.4.10	6-16-00
THROTTLE VALVES - (CHANGING AND ADJUSTING THE POTENTIOMETER)	4.8.9	4-25-00
TOOLS - (FOR ENGINE)	1.7.4	1-16-00
TOOLS - (FOR FORK)	1.7.3	1-15-00
TOOLS - (FOR FRAME COMPONENTS)	1.7.2	1-15-00
TOOLS - (MISCELLANEOUS)	1.7.5	1-18-00
TOOLS - (USED FOR OTHER aprilia VEHICLES)	1.7.6	1-20-00
TRANSFERS	1.11	1-35-00
TREAD	2.37.1	2-61-00
TROUBLESHOOTING	8.1	8-3-00
TYRE - (ASSEMBLY)	7.4.3	7-68-00
TYRE - (DISASSEMBLY)	7.4.1	7-67-00
TYRES	2.37	2-61-00
	7.4	7-67-00

U		
UPDATING OF THE MANUAL	0.1.1	0-3-00

V		
VALVES	2.43	2-65-00
VOLTAGE REGULATOR	6.3.4	6-7-00

W	Ref.	Page
WHOLE FINAL DRIVE UNIT - (REMOVAL)	7.3.2	7-54-00
WIRING DIAGRAM - RSV mille	6.18	6-50-00
WIRING DIAGRAM - RSV mille ASD	6.19	6-52-00

X	Ref.	Page
-	-	-

Y	Ref.	Page
-	-	-

Z	Ref.	Page
-	-	-

NOTES

Lined area for taking notes.

THIS PAGE HAS BEEN INTENTIONALLY LEFT EMPTY



aprilia s.p.a.
Technical After-Sales Department - Technical Documentation Department
via G. Galilei, 1 - 30033 Noale (VE) - Italia
tel. +39 041.5829101
fax +39 041.5829190

www.aprilia.com
www.serviceaprilia.com