

aprilia

1136 3 RSV 1000 R - RSV 1000 R FACTORY

00/2003-08

www.serviceaprilia.com

workshop manual



8140741

INTRODUCTION

SUMMARY

0.1. INTRODUCTION 3
0.1.1. INTRODUCTION 3
0.1.2. REFERENCE MANUALS 4
0.1.3. ABBREVIATIONS/SYMBOLS/CONVENTIONS 5

0.1. INTRODUCTION

0.1.1. INTRODUCTION

- This manual provides the information required for normal servicing.
- This publication is intended for use by **aprilia** dealerships and their qualified mechanics; many concepts have been omitted inasmuch as their inclusion would be superfluous for such an audience. Since complete mechanical explanations have not been included in this manual, the reader must be familiar with basic notions of mechanics, as well as with basic repair procedures. Without such familiarity, repairs and checks could be ineffective and even hazardous. Since the repair and vehicle check instructions are not exhaustive, special care must be taken to avoid damage and injury. To ensure maximum customer satisfaction with the vehicle, **aprilia spa** continuously improves its products and their documentation. The main technical modifications and changes in repair procedures are communicated to all **aprilia** dealerships and agencies worldwide. Such modifications will be entered in subsequent editions of the manual. In case of doubt regarding specific repairs or checks, contact the **aprilia** SERVICE DEPARTMENT; we will be pleased to provide all necessary information and assistance as well as keeping you updated on changes and modifications to the vehicle.

aprilia s.p.a. reserves the right to make changes to its products at any time, barring any such changes as may alter the essential features of a product as specified in the relevant manual.

All rights of storage using electronic means, reproduction and total or partial adaptation, whatever the means adopted, are reserved in all countries.

The mention of third parties' products is only made for information purposes, and constitutes no engagement.

aprilia spa is not liable in any way for the performance or use of its products.

First edition: July 2003

Designed and printed by:

DECA srl

via Risorgimento, 23/1 - 48022 Lugo (RA) - Italy

Tel. +39 - 0545 35235

Fax +39 - 0545 32844

E-mail: deca@decaweb.it

www.decaweb.it

On behalf of:

aprilia S.p.A.

Via G. Galilei, 1 – 30033 Noale (VE) – Italy

Tel. +39 – (0)41 58 29 111

Fax +39 – (0)41 58 29 190

www.aprilia.com

www.serviceaprilia.com

0.1.2. REFERENCE MANUALS

PARTS CATALOGUES

aprilvia part# (descrizione)	I	F	D	E	UK
3974					

SPECIAL TOOLS CATALOGUES

aprilvia part# (descrizione)	I	F	D	E	UK
001A00					

OWNER'S MANUALS

aprilvia part# (descrizione)	I	F	D	P	E	UK	NL	DK	SF	GR	J	USA	AUS	CHN
8104334														
8104691														
8104692														
8104693														
8104704														
8104694														
8104695														

CYCLE PARTS TECHNICAL MANUAL

aprilvia part# (descrizione)	I	E	F	D	UK	USA
8140737						
8140738						
8140739						
8140740						
8140741						
8140742						

ENGINE TECHNICAL MANUAL

aprilvia part# (descrizione)	I	E	F	D	UK	USA
8140743						
8140744						
8140745						
8140746						
8140747						
8140748						

0.1.3. ABBREVIATIONS/SYMBOLS/CONVENTIONS

#	= number
<	= less than
>	= greater than
≤	= less than or equal to
≥	= more than or equal to
~	= approximately
∞	= infinity
°C	= degrees Celsius (centigrade)
°F	= degrees Fahrenheit
±	= plus or minus
AC	= alternating current
A	= Ampere
Ah	=Ampere per hour
API	= American Petroleum Institute
HV	= high voltage
AV/DC	= Anti-Vibration Double Countershaft
bar	= pressure measurement (1 bar =100 kPa)
DC.	= Direct Current
cc	= cubic centimetres
CO	= carbon monoxide
CPU	= Central Processing Unit
DIN	= German industrial standards (Deutsche Industrie Norm)
DOHC	= Double Overhead Camshaft
ECU	= Electronic Control Unit
rpm	= revolutions per minute
HC	= unburnt hydrocarbons
ISC	= Idle Speed Control
ISO	= International Standardization Organization
Kg	= kilograms
Kgm	= kilogram metre (1 kgm =10 Nm)
km	= kilometres
kph	= kilometres per hour
kΩ	= kilo Ohm
kPa	= kiloPascal (1 kPa =0.01 bar)
KS	= clutch side (from the German "Kupplungseite")
kW	= kiloWatt
/	= litres
LAP	= racetrack lap
LED	= Light Emitting Diode
LEFT	
SIDE	= left side
m/s	= metres per second
max	= maximum
mbar	= millibar (1 mbar =0.1 kPa)
mi	= miles
MIN	= minimum
MPH	= miles per hour
MS	= flywheel side (from the German "Magnetoseite")
MΩ	= megaOhm
N.A.	= Not Available
N.O.M.M.	= Motor Octane Number
N.O.R.M.	= Research Octane Number
Nm	= Newton metre (1 Nm =0.1 kgm)
Ω	= ohm
PICK-UP	= pick-up
BDC	= Bottom Dead Centre
TDC	= Top Dead Centre
PPC	= Pneumatic Power Clutch

RIGHT	
SIDE	= right side
SAE	= Society of Automotive Engineers
TEST	= diagnostic check
T.B.E.I.	= crown-head Allen screw
T.C.E.I.	= cheese-head Allen screw
T.E.	=hexagonal head
TP	= flat head screw
TSI	= Twin Spark Ignition
UPSIDE-	
DOWN	= inverted fork
V	= Volt
W	= Watt
Ø	= Diameter

GENERAL INFORMATION

SUMMARY



1.1. STRUCTURE OF THE MANUAL..... 3
1.1.1. CONVENTIONS USED IN THE MANUAL 3
1.1.2. SAFETY WARNINGS..... 4
1.2. GENERAL RULES..... 5
1.2.1. BASIC SAFETY RULES..... 5
1.3. DANGEROUS ELEMENTS 8
1.3.1. WARNINGS 8
1.4. RUNNING-IN 12
1.4.1. RUNNING-IN RECOMMENDATIONS..... 12
1.5. VEHICLE IDENTIFICATION 13
1.5.1. POSITION OF THE SERIAL NUMBERS 13

1.1. STRUCTURE OF THE MANUAL









1.1.1. CONVENTIONS USED IN THE MANUAL

- This manual is divided in sections and subsections, each covering a set of the most significant components. Refer to the index of sections when consulting the manual.
- Unless expressly specified otherwise, assemblies are reassembled by reversing the dismantling procedure.
- The terms "right" and "left" are referred to the rider seated on the vehicle in the normal riding position.
- Motorcycle operation and basic maintenance are covered in the «OWNER'S MANUAL».

In this manual any variants are identified with these symbols:

	optional
	catalytic version
-	all versions
MP	national certification
SF	European certification (EURO 1 limits)

VERSION:

	Italy		Greece		Malaysia
	United Kingdom		Holland		Chile
	Austria		Switzerland		Croatia
	Portugal		Denmark		Australia
	Finland		Japan		United States of America
	Belgium		Singapore		Brazil
	Germany		Slovenia		South Africa
	France		Israel		New Zealand
	Spain		South Korea		Canada

1.1.2. SAFETY WARNINGS

The following precautionary warnings are used throughout this manual in order to convey the following messages:



Safety warning. This symbol appears, whether in the manual or on the vehicle itself, to indicate a personal injury hazard. Non-compliance with the indications given in the messages preceded by this symbol may result in grave risks for your and other people's safety and for the vehicle!

**WARNING**

Indicates a potential hazard which may result in serious injury or even death.

**CAUTION**

Indicates a potential hazard which may result in minor personal injury or damage to the vehicle.

IMPORTANT: *The word "IMPORTANT" in this manual precedes important information or instructions*

1.2. GENERAL RULES

1.2.1. BASIC SAFETY RULES

CARBON MONOXIDE

Should it be necessary to perform some operations with the vehicle running, make sure to work outdoors or in a well-aerated room.

Avoid starting the engine in closed or badly-ventilated rooms.

In case you are working indoors, make use of an exhaust gases scavenging system.



DANGER

Exhaust gases contain carbon monoxide, which is extremely toxic if inhaled and may cause loss of consciousness or even lead to death by asphyxia.

FUEL



DANGER

The fuel used to operate engines is highly flammable and becomes explosive under particular conditions. Refuelling and engine service should take place in a well-ventilated area with the engine stopped. Do not smoke when refuelling or in the proximity of sources of fuel vapours, avoid flames, sparks and any element that could ignite fuel or provoke explosions.

DO NOT DISPOSE OF FUEL IN THE ENVIRONMENT.

KEEP AWAY FROM CHILDREN.

HIGH-TEMPERATURE COMPONENTS

The engine and the exhaust system parts become hot and continue to be hot even for some time after the engine has been stopped.

Before handling these parts, wear insulating gloves or wait for the engine and the exhaust system to cool completely down.

USED GEARBOX AND FORK OILS



DANGER

In case any maintenance operation should be required, it is advisable to use latex gloves.

Gear oil may cause serious damage to the skin if handled daily and for long periods.

Wash your hands carefully after use.

Put it in a sealed container and take it to the filling station where you usually buy it or to an oil salvage center.

In case any maintenance operation should be required, it is advisable to use latex gloves.

DO NOT DISPOSE OF OIL IN THE ENVIRONMENT

KEEP AWAY FROM CHILDREN.

BRAKE FLUID



WARNING

When using the brake fluid, take care not to spill it on the plastic, rubber or painted parts, since it can damage them.

When carrying out the maintenance operations on the braking system, use a clean cloth to cover these parts.

Always wear safety goggles when working on the braking system.

The brake fluid is highly irritant. Avoid contact with your eyes.

If the brake fluid gets in contact with the skin or the eyes, carefully wash the parts of your body that get in contact with the fluid and consult a doctor.

KEEP AWAY FROM CHILDREN.

COOLANT

The coolant is composed of ethylene glycol that, under certain conditions, can become inflammable and send out invisible flames causing severe burns.

**DANGER**

Be careful not to spill the coolant on the red-hot parts of the engine and the exhaust system: it may catch fire and send out invisible flames.

In case any maintenance operation should be required, it is advisable to use latex gloves.

Even if toxic, coolant has a sweet flavour. Never leave it inside open containers or within the reach of animals to prevent the risk of drinking.

KEEP AWAY FROM CHILDREN.

Do not remove the radiator plug when the engine is hot. The coolant is under pressure and could cause severe burns.

HYDROGEN GAS AND BATTERY ELECTROLYTE**DANGER**

The battery electrolyte is a toxic, caustic substance containing sulphuric acid and thus able to cause severe burns in case of contact.

Always wear tight gloves and protective clothes when handling this fluid.

If the electrolyte gets in contact with the skin, carefully wash the parts of your body that get in contact with the fluid with abundant fresh water.

Always use a protection for your eyes since also a very small amount of the battery fluid can cause blindness. In the event of contact with your eyes, carefully wash them with water for fifteen minutes and then consult immediately an eye specialist.

Should you accidentally drink some fluid, drink abundant water or milk, then drink magnesia milk or vegetable oil and consult immediately a doctor. Battery releases explosive gases. Keep flames, sparks, cigarettes and any other heat source away from the battery. Make sure the room is well-aerated when servicing or recharging the battery.

KEEP AWAY FROM CHILDREN.

The battery fluid is corrosive

Do not pour it on the plastic parts.

Make sure that the electrolyte acid is suitable for the type of battery used.

GENERAL PRECAUTIONS AND INFORMATION

Follow these instructions closely when repairing, disassembling or reassembling the motorcycle or its components.

**DANGER**

Using bare flames is strictly forbidden when working on the motorcycle. Before servicing or inspecting the motorcycle: stop the engine and remove the key from the ignition switch; allow for the engine and exhaust system to cool down; where possible, lift the motorcycle using adequate equipment placed on firm and level ground. Be careful of any parts of the engine or exhaust system which may still be hot to the touch to avoid scalds or burns.

Never put any mechanical parts or other vehicle components in your mouth when you have both hands busy. None of the motorcycle components is edible. Some components are harmful to the human body or toxic.

Unless expressly specified otherwise, motorcycle assemblies are refitted or re-assembled by reversing the removal or dismantling procedure. Where a procedure is cross-referred to relevant sections in the manual, proceed sensibly to avoid disturbing any parts unless strictly necessary. Never attempt to polish matte-finished surfaces with lapping compounds.

Never use fuel instead of solvent to clean the motorcycle.

Do not clean any rubber or plastic parts or the seat with alcohol, petrol or solvents. Clean with water and neutral detergent.

Always disconnect the battery negative (-) lead before soldering any electrical components.

When two or more persons service the same motorcycle together, special care must be taken to avoid personal injury.

BEFORE DISASSEMBLING ANY COMPONENTS

Clean off all dirt, mud, and dust and clear any foreign objects from the vehicle before disassembling any components.

Use the model-specific special tools where specified.

DISASSEMBLING THE COMPONENTS

Never use pliers or similar tools to slacken and/or tighten nuts and bolts. Always use a suitable spanner.
Mark all connections (hoses, wiring, etc.) with their positions before disconnecting them. Identify each connection using a distinctive symbol or convention.
Mark each part clearly to avoid confusion when refitting.
Thoroughly clean and wash any components you have removed using a detergent with low flash point.
Mated parts should always be refitted together. These parts will have seated themselves against one another in service as a result of normal wear and tear and should never be mixed up with other similar parts on refitting.
Certain components are matched-pair parts and should always be replaced as a set.
Keep the motorcycle and its components well away from heat sources.

REASSEMBLING THE COMPONENTS



DANGER

Never reuse a circlip or snap ring. These parts must always be renewed once they have been disturbed. When fitting a new circlip or snap ring, take care to move the open ends apart just enough to allow fitment to the shaft.

Make a rule to check that a newly –fitted circlip or snap ring has located fully into its groove.

Never clean a bearing with compressed air.

NOTE All bearings must rotate freely with no hardness or noise. Replace any bearings that do not meet these requirements.

Use ORIGINAL **aprilia** SPARE PARTS only.

Use the specified lubricants and consumables.

Where possible, lubricate a part before assembly.

When tightening nuts and bolts, start with the largest or innermost nut/bolt and observe a cross pattern. Tighten evenly in subsequent steps until achieving the specified torque.

Replace any self-locking nuts, gaskets, seals, circlips or snap rings, O-rings, split pins, bolts and screws which have a damaged thread.

Lubricate the bearings abundantly before assembly.

Make a rule to check that all components you have fitted are correctly in place.

After repairing the motorcycle and after each service inspection, perform the preliminary checks, and then operate the motorcycle in a private estate area or in a safe area away from traffic.

Clean all joint surfaces, oil seal edges and gaskets before assembly. Apply a light coat of lithium grease along the edges of oil seals. Fit oil seals and bearings with the marking or serial number facing outwards (in view).

ELECTRICAL CONNECTORS

To disconnect the electrical connector, follow the procedures below. Failure to comply with these procedures may lead to irreparable damages to the connector and the wiring as well. If present, press the special safety hooks.



WARNING

Do not pull cables to disconnect the two connectors.

Grasp the two connectors and disconnect them by pulling them in the two opposite directions.

In case of dirt, rust, moisture, etc., thoroughly clean the inside of the connectors with compressed air.

Make sure that the cables are correctly fitted inside the connectors terminals.

NOTE The two connectors have just one correct positioning. Make sure to position them in the right direction.

Then fit the two connectors. Make sure they are correctly coupled (a click will be heard).

TIGHTENING TORQUE SETTINGS



DANGER

Always remember that the tightening torque settings of all wheel, brake, wheel shaft and other suspension parts play a fundamental role to ensure vehicle safety. Make sure that these values are always within the specified limits.

Check fastening parts tightening torque settings at regular intervals. Upon reassembly, always use a torque wrench.

Failure to comply with these recommendations could lead to the loosening and detachment of one of these parts with a consequent locking of the wheel or other serious troubles affecting the vehicle maneuverability, and thus the risk of falls and serious injuries or death.

1.3. DANGEROUS ELEMENTS

1.3.1. WARNINGS

FUEL

**DANGER**

The fuel used to operate engines is highly flammable and becomes explosive under particular conditions. Refuelling and engine service should take place in a well-ventilated area with the engine stopped. Do not smoke when refuelling or in the proximity of sources of fuel vapours. Avoid contact with bare flames, sources of sparks or any other source which may ignite the fuel or lead to explosion.

Take care not to spill fuel out of the filler, or it may ignite when in contact with hot engine parts. In the event of accidental fuel spillage, make sure the affected area is fully dry before starting the engine. Fuel expands from heat and when left under direct sunlight.

Never fill the fuel tank up to the rim. Tighten the filler cap securely after each refuelling.

Avoid contact with skin. Do not inhale vapours. Do not swallow fuel. Do not transfer fuel between different containers using a hose.

DO NOT RELEASE FUEL INTO THE ENVIRONMENT.

KEEP AWAY FROM CHILDREN.

Use only premium grade unleaded petrol, min. O.N. 95 (N.O.R.M.) and 85 (N.O.M.M.).

LUBRICANTS

**DANGER**

A good lubrication ensures the vehicle safety.

Failure to keep the lubricants at the recommended level or the use of a non-suitable new and clean type of lubricant can lead to the engine or gearbox seizure, thus leading to serious accidents, personal injury or even death.

Gear oil may cause serious damage to the skin if handled daily and for long periods.

Wash your hands carefully after use.

Do not dispose of oil into the environment.

Take it to the filling station where you usually buy it or to an oil salvage center.

**WARNING**

When filling the vehicle with this oil, take care not to spill it out since it could damage the vehicle paintwork.

In case of contact with oil, the tyres surface will become very slippery, thus becoming a serious danger for your safety.

In case of leaks, do not use the vehicle. Check and trace the cause of leaks and proceed to repair.

ENGINE OIL

**DANGER**

Prolonged or repeated contact with engine oil may cause severe skin damage.

Wash your hands thoroughly after handling engine oil.

Do not release into the environment.

Dispose of engine oil through the nearest waste oil reclamation firm or through the supplier.

Wear latex gloves during servicing

FRONT FORK FLUID

**DANGER**

Front suspension response can be modified to a certain extent by changing damping settings and/or selecting a particular grade of oil. Standard oil grade is SAE 20 W. Different oil grades can be selected to obtain a particular suspension response. (Choose SAE 5W for a softer suspension, 20W for a stiffer suspension).

The two grades can also be mixed in varying solutions to obtain the desired response.

BRAKE FLUID

NOTE This vehicle is fitted with front and rear disc brakes. Each braking system is operated by an independent hydraulic circuit. The information provided below applies to both braking systems.

**DANGER**

Do not use the vehicle in case brakes are worn out or do not work properly! The brakes are the parts that most ensure your safety and for this reason they must always be perfectly working. Failure to comply with these recommendations will probably lead to a crash or an accident, with a consequent risk of personal injury or death.

A wet surface reduces brakes efficiency.

**DANGER**

In case of wet ground the braking distance will be doubled, since both brakes and tyres drives on the road surface are extremely reduced by the water present on the road surface.

Any water on brakes, after washing the vehicle or driving on a wet road surface or crossing puddles or gips, can wet brakes so as to greatly reduce their efficiency.

Failure to comply with these recommendations may lead to serious accidents, with a consequent risk of severe personal injuries or death.

Brakes are critical safety components. Do not ride the vehicle in case brakes are not working at their best.

Check for brakes proper operation before every trip.

Brake fluid is an irritant. Avoid contact with eyes or skin.

In the event of accidental contact, wash affected body parts thoroughly. In the event of accidental contact with eyes, contact an eye specialist or seek medical advice.

DO NOT RELEASE BRAKE FLUID INTO THE ENVIRONMENT.KEEP AWAY FROM CHILDREN.

When handling brake fluid, take care not to spill it onto plastic or paint-finished parts or they will damage.

**DANGER**

Do not use any brake fluids other than the specified type. Never mix different types of fluids to top up level, as this will damage the braking system.

Do not use brake fluid from containers which have been kept open or in storage for long periods.

Any sudden changes in play or hardness in the brake levers are warning signs of problems with the hydraulic circuits.

Ensure that the brake discs and brake linings have not become contaminated with oil or grease. This is particularly important after servicing or inspections.

Make sure the brake lines are not twisted or worn.

Prevent accidental ingress of water or dust into the circuit.

Wear latex gloves when servicing the hydraulic circuit.

DISC BRAKES**DANGER**

The brakes are the parts that most ensure your safety and for this reason they must always be perfectly working; check them before every trip.

A dirty disc soils the pads.

Dirty pads must be replaced, while dirty discs must be cleaned with a high-quality degreaser.

Perform the maintenance operations with half the indicated frequency if the vehicle is used in rainy or dusty areas, on uneven surfaces or on racetracks.

When the disc pads wear out, the level of the fluid decreases to automatically compensate for their wear.

The front brake fluid reservoir is located on the right handlebar, near the front brake lever.

The rear brake fluid reservoir is located under the right fairing.

Do not use the vehicle if the braking system leaks fluid.

COOLANT

**DANGER**

Coolant is toxic when ingested and is an irritant, contact with eyes or skin may cause irritation. In the event of contact with eyes, rinse repeatedly with abundant water and seek medical advice. In the event of ingestion, induce vomiting, rinse mouth and throat with abundant water and seek medical advice immediately.

**DO NOT RELEASE INTO THE ENVIRONMENT.
KEEP AWAY FROM CHILDREN.**

**DANGER**

Take care not to spill coolant onto hot engine parts. It may ignite and produce invisible flames. Wear latex gloves when servicing.

Do not ride when coolant is below the minimum level.

Coolant mixture is a 50% solution of water and anti-freeze. This is the ideal solution for most operating temperatures and provides good corrosion protection.

This solution is also suited to the warm season, as it is less prone to evaporative loss and will reduce the need for top-ups.

In addition, less water evaporation means fewer minerals salts depositing in the radiator, which helps preserve the efficiency of the cooling system.

When temperature drops below zero degrees centigrade, check the cooling system frequently and add more anti-freeze (up to 60% maximum) to the solution.

Use distilled water in the coolant mixture. Tap water will damage the engine.

Refer to the chart given below and add water with the quantity of anti-freeze to obtain a solution with the desired freezing point:

Freezing point °C	Coolant % of volume
-20°	35
-30°	45
-40°	55

NOTE Coolants have different specifications. The protection degree is written on the label.

**WARNING**

Use nitrate-free coolant only, with a protection until at least -35°C.

DRIVE CHAIN

Check drive chain operation, slack and lubrication at regular intervals.

The vehicle is equipped with an endless chain with a joint link.

**WARNING**

If too slack, the chain can come off the front or rear sprockets thus leading to serious accidents and damage to the vehicle, with consequent serious personal injury or death.

Do not use the vehicle if the chain tension has not been correctly adjusted.

To check chain, take it with your hand where it turns on the rear sprocket and pull it as to separate it from the crown itself.

If you can move the chain apart of the front sprocket for more than 3 mm (0.125 in), change chain, crown and pinion.

**DANGER**

If not properly maintained, chain can early wear out and lead to the damage of both crown and pinion.

Perform chain maintenance operations more frequently if the vehicle is used on rainy or dusty areas.

TYRES

**WARNING**

If tyres are excessively inflated, the vehicle will be hard and uneasy to ride, thus making you feel not at your ease.

In addition the roadworthiness, mainly on wet surfaces and during cornering, will be impaired.

Flat tyres (insufficient pressure) can slip on the rim and make you lose the control of the vehicle.

In this case too, both vehicle roadworthiness, maneuverability and brake efficiency will be impaired.

Tyres changing, repair, maintenance and balancing must be carried out by specialized technicians using suitable equipment.

When new, tyres can have a thin slippery protective coating. Drive carefully for the first kilometers (miles). Never use rubber treating substances on tyres.

In particular, avoid contact with fluid fuels, leading to a rapid wear.

In case of contact with oil or fuel, do not clean but change tyres.

**DANGER**

Some of the factory-assembled tyres of this vehicle are provided with wear indicators.

There are several kinds of wear indicators.

For more information on how to check the wear, contact your Dealer.

Visually check if the tyres are worn and in this case have them changed.

If a tyre deflates while driving, stop immediately.

Avoid hard brakings or moves and do not close throttles too abruptly.

Slowly close throttle grip, move to the edge of the road and make use of the engine brake to slow down until coming to a halt.

Failure to comply with these recommendations can lead to serious accidents and consequent personal injuries or death.

Do not install tyres with air tube on rims for tubeless tyres and viceversa.

1.4. RUNNING-IN

1.4.1. RUNNING-IN RECOMMENDATIONS

The running-in of the engine is essential to ensure its duration and correct functioning.

If possible, drive on hilly roads and/or roads with many bends, so that the engine, the suspensions and the brakes undergo a more effective running-in.

During running-in, change speed.

In this way the components are first "loaded" and then "relieved" and the engine parts can thus cool down.

Even if it is important to stress the engine components during running-in, take care not to exceed.



WARNING

Only after the first 1500 km (932 mi) of running-in you can expect the best performance levels from the vehicle.

Keep to the following indications:

- Do not open the throttle completely if the speed is low, both during and after the running-in.
- During the first 100 km (62 mi) pull the brakes with caution, avoiding sharp and prolonged brakings. This ensures a correct bedding-in of the pads on the brake disc.
- During the first 1000 km (621 mi) never exceed 6000 rpm (see table).



WARNING

After the first 1000 km (621 mi), Dealer carry out the checks indicated in the column "After running-in", see (REGULAR SERVICE INTERVALS CHART), in order to avoid hurting yourself or other people and/or damaging the vehicle.

- Between the first 1000 km (621 mi) and 1500 km (932 mi) drive more briskly, change speed and use the maximum acceleration only for a few seconds, in order to ensure better coupling of the components; never exceed 7500 rpm (see table).
- After the first 1500 km (932 mi) you can expect better performance from the engine, however, without exceeding the maximum allowed [11000 rpm].

Engine maximum rpm recommended	
Mileage km (mi)	rpm
0÷1000 (621)	6000
1000÷1500 (621÷ 932)	7500
over 1500 (932)	11000

1.5. VEHICLE IDENTIFICATION

1.5.1. POSITION OF THE SERIAL NUMBERS

These numbers are necessary for the registration of the vehicle.

IMPORTANT Do not alter the identification numbers if you do not want to incur severe penal and administrative sanctions; in particular, altering the frame number voids the warranty.

FRAME NUMBER

The frame number (1) is stamped on the right hand side of the headstock.

ENGINE NUMBER

The engine number (2) is stamped on the rear part of the engine, near the pinion.

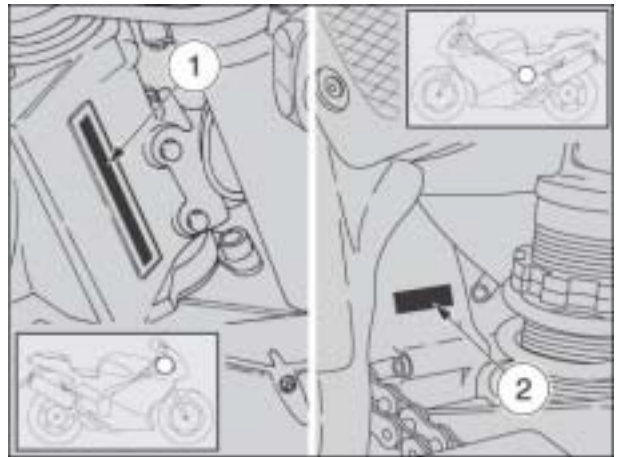

GENERAL TECHNICAL INFORMATION 2

SUMMARY

2.1. GENERAL TECHNICAL INFORMATION 3

2.1.1. TECHNICAL DATA 3

2.1.2. PERIODIC MAINTENANCE CHART 7

2.1.3. TABLE OF LUBRICANTS 9

2.1.4. TIGHTENING TORQUES 10

2.1.5. SPECIAL TOOLS 14

2.1.6. ARRANGEMENT OF THE MAIN ELEMENTS 21

2.1.7. ARRANGEMENT OF THE INSTRUMENTS/CONTROLS 25

2.1.8. DASHBOARD OPERATION 26

2.1.9. SYSTEMS DIAGRAM 34

2.1. GENERAL TECHNICAL INFORMATION

2.1.1. TECHNICAL DATA

DIMENSIONS	
Max. length	2025 mm
Max. length	730 mm
Max. height (incl. Windshield)	1135 mm
Rider saddle height	820 mm
Wheelbase	1410 mm
Minimum ground clearance	130 mm
Weight in running order	RSV R 215 kg – RFACT 209 kg

ENGINE	
Model	V990 NG
Type	4-stroke V 60* twin-cylinder, with 4 valves per cylinder, DOHC.
No. of cylinders	2
Total displacement	997,6 cm ³
Bore/stroke	97 mm/67,5 mm
Compression ratio	11,8 ± 0,4: 1
Starting	Electric starter
Engine idling speed	1280 ± 100 rpm
Clutch	Multiplate wet clutch, hydraulically operated, control on left side of handlebar and PPC device
Lubricating system	Dry sump with separate oil tank and oil cooler
Air cleaner	Dry filter cartridge
Cooling system	Liquid cooling

GEARBOX	
Type	Mechanical, 6 gears with foot control on left side of engine

CAPACITIES	
Fuel (including reserve)	18 l
Fuel reserve	4,5 ± 1 l
Engine oil	oil change 3700 cu cm - oil and oil filter change 3900 cu cm
Front fork oil RSV R	520 ± 2.5 cu cm (each leg)
Front fork "R FACTORY" RFACT (RSV R OPT) oil	500 ± 2.5 cu cm (each leg)
Coolant	2,2 l (50% water + 50% anti-freeze with ethylene glycol)
Saddle	2 (RFACT USA version: single-seater only)
Max. load	RSV R 180 kg (driver + passenger + luggage) – RFACT USA 105 kg

TRANSMISSION RATIOS				
Ratio	Primary	Secondary	Final drive	Total ratio
1st	31/60 = 1: 1,935	15/34 = 1: 2,267	16/40 = 1: 2,500	1:10,968
2nd		19/31 = 1: 1,632		1:7,895
3rd		20/26 = 1: 1,300		1:6,290
4th		22/24 = 1: 1,091		1:5,279
5th		25/24 = 1: 0,960		1:4,645
6th		26/23 = 1: 0,885		1:4,280

DRIVE CHAIN	
Type	Endless (with no master link) with O-ring links
Endless	525

FUEL SYSTEM	
Type	Electronic injection (Multipoint)
Choke	Ø 57 mm

FUEL	
Fuel	Premium-grade unleaded petrol, minimum octane rating 95 (ROM) and 85 (MON).

FRAME	
Type	Two-beam frame with light alloy cast elements and extruded elements
Steering head angle	25°
Trail	100 mm (with 120/70 front tyre)

SUSPENSION	
Front	Adjustable hydraulic upside-down fork, Ø 43 mm
Travel	RSV R 127 mm – RFACT(RSV R OPT) 120 mm
Rear	Light-alloy swinging arm with differentiated profiles on both sides and adjustable air/oil-sprung mono-shock absorber
Wheel travel	135 mm

BRAKES	
Front	Twin floating disk - Ø 320 mm, four-piston callipers - Ø 34 mm
Rear	Disk brake - Ø 220 mm, twin-piston calliper - Ø 32 mm

WHEEL RIMS	
Type	Light alloy, spindle can be removed
Front	3,50 x 17"
Rear	6,00 x 17"

TYRES											
Wheel	Make	Model	Type	Size	Recommended		Alternative	Pressure kPa (bar)			
								#		\$	
								Rider	Rider and passenger	Rider	
** Front	PIRELLI	DIABLO	CORSA	120/70-ZR 17"	#	\$	RSV R + R FACT	230 (2,3)	250 (2,5)	210 (2,1)	
** Rear	PIRELLI	DIABLO	CORSA	190/50-ZR 17"	#	\$	RSV R + R FACT	250 (2,5)	280 (2,8)	200 (2,0)	
* Front	PIRELLI	DRAGON SUPER- CORSA	-	120/70-ZR 17"	#	\$	RSV R + R FACT	230 (2,3)	250 (2,5)	210 (2,1)	
* Rear	PIRELLI	DRAGON SUPER- CORSA	-	180/55-ZR 17"	#	\$	RSV R + R FACT	250 (2,5)	280 (2,8)	200 (2,0)	
** Front	METZELER	SPOR- TTEC	M1	120/70-ZR 17"	#	\$	RSV R + R FACT	230 (2,3)	250 (2,5)	210 (2,1)	
Rear	METZELER	SPOR- TTEC	M1	180/55-ZR 17"	#	\$	RSV R + R FACT	250 (2,5)	280 (2,8)	200 (2,0)	
** Rear	METZELER	SPOR- TTEC	M1	190/50-ZR 17"	#	\$	RSV R + R FACT	250 (2,5)	280 (2,8)	200 (2,0)	
Front	METZELER	REN- NSPORT	-	120/70-ZR 17"	-	\$	RSV R + R FACT	-	-	210 (2,1)	
Rear	METZELER	REN- NSPORT	-	180/55-ZR 17"	-	\$	RSV R + R FACT	-	-	200 (2,0)	
** Front	MICHELIN	PILOT SPORT	E	120/70-ZR 17" TL	#	-	RSV R	230 (2,3)	250 (2,5)	-	
** Rear	MICHELIN	PILOT SPORT	E	190/50-ZR 17" TL	#	-	RSV R	250 (2,5)	280 (2,8)	-	
Front	MICHELIN	PILOT SPORT CUP	-	120/70-ZR 17"	-	\$	RFACT	-	-	210 (2,1)	
Front	MICHELIN	PILOT SPORT CUP	-	180/55-ZR 17"	-	\$	RFACT	-	-	190 (1,9)	
Front	MICHELIN	PILOT RACE	H 2	120/70-ZR 17"	-	\$	RFACT	-	-	210 (2,1)	
Rear	MICHELIN	PILOT RACE	H 2	180/55-ZR 17"	-	\$	RFACT	-	-	190 (1,9)	
** Front	DUNLOP	SPOR- TMAX	D 208	120/70-ZR 17"	#	-	RSV R+ RFACT	230 (2,3)	250 (2,5)	-	
** Rear	DUNLOP	SPOR- TMAX	D 208	190/50-ZR 17"	#	-	RSV R+ RFACT	250 (2,5)	280 (2,8)	-	
Front	DUNLOP	SPOR- TMAX	D 208 RR	120/55-ZR 17"	-	\$	RFACT	-	-	210 (2,1)	
Rear	DUNLOP	SPOR- TMAX	D 208 RR	180/55-ZR 17"	-	\$	RFACT	-	-	190 (1,9)	
* = standard RFACT		**= standard RSV R		# = Standard use				\$= Racing use			

SPARK PLUGS	
Standard	NGK R DCPR9E
Electrode gap	0,8 mm
Resistance	5 k Ω

ELECTRIC SYSTEM	
Battery	12 V – 10 Ah
Main fuses	30 A
Auxiliary fuses	5 A, 15 A, 20 A
Generator (permanent-wound type)	12 V – 500 W

BULBS	
Low beam (halogen)	12 V – 55 W H7U x 2
High beam (halogen)	12 V – 55 W H7U x 2
Front parking light	12 V – 5 W
Direction indicators	12 V – 10 W
Number plate light	12 V – 5 W
Stop/rear parking lights	LED
Rev counter light	LED
Left multifunction display	LED

WARNING LIGHTS	
Neutral	LED
Direction indicators	LED
Fuel reserve	LED
High beam	LED
Stand down	LED
General warning	LED
Red line	LED
Immobilizer	LED

2.1.2. PERIODIC MAINTENANCE CHART

OPERATIONS TO BE CARRIED OUT BY THE **aprilia** Official dealer (CAN BE CARRIED OUT BY THE USER AS WELL).

Key

- 1 = check and clean, adjust, lubricate or replace, if necessary;
- 2 = clean;
- 3 = replace
- 4 = adjust.

(*) = Check every two weeks or at the specified intervals.

NOTE Halve maintenance intervals if the vehicle is used in rainy or dusty conditions, on rough roads or for racing.

Component	Post running-in [1000 Km (625 mi)]	Every 5000 Km (3125 mi) (only for inten- sive racing use)	Every 10000 Km (6250 mi) or 12 months	Every 20000 Km (12500 mi) or 24 months
Spark plug		3	1	3
Air cleaner		3	1	3
Engine oil filter	3	3	3	
Engine oil filter (on oil tank)	2	2		2
Light operation/beam setting			1	
Light system	1		1	
Safety switches	1		1	
Clutch fluid	1	1	1	
Brake fluid	1	1	1	
Coolant	1	1		1
Engine oil	3	3	3	
Tyres	1		1	
Tyre pressure (*)	4		4	
Error warning light (on dashboard) 	each start-up: 1			
Drive chain slack and lubri- cation	every 1000 Km (625 mi): 1			
Brake pad wear	1	every 1000 Km (625 mi): 1	before each ride and every 2000 Km (1250 mi): 1	

OPERATIONS TO BE CARRIED OUT BY THE **aprilia** Official dealer.

Key





























- 1 = check and clean, adjust, lubricate or replace, if necessary;
- 2 = clean;
- 3 = replace
- 4 = adjust.

(*) = only for versions with magnesium wheels: check that rim paint is in good conditions.

NOTE Halve maintenance intervals if the vehicle is used in rainy or dusty conditions, on rough roads or for racing.

Component	Post running-in [1000 Km (625 mi)]	Every 5000 Km (3125 mi) (only for inten- sive racing use)	Every 10000 Km (6250 mi) or 12 months	Every 20000 Km (12500 mi) or 24 months
Rear shock absorber		1		1
Gearbox		every 10000 Km (6250 mi): 1		
Bowden cables and con- trols	1	1	1	
Rear suspension linkage bearings				1
Steering bearings and steering play	1	1	1	
Wheel bearings		1	1	
Brake disks	1	1	1	
Vehicle operation	1	1	1	
Valve clearance	4			4
Braking systems	1	1	1	
Cooling system		1	1	
Clutch fluid		every 12 months: 3	every 24 months: 3	
Brake fluid		every 12 months: 3	every 24 months: 3	
Coolant			every 24 months: 3	
Fork oil (RSV R)			After the first 10000 Km (6250 mi) and every 20000 Km (12500 mi) afterwards: 3	
Fork oil (RFACT)		3	3	
Fork oil seals (RSV R)			After the first 30000 Km (18650 mi) and every 20000 Km (12500 mi) afterwards: 3	
Fork oil seals (RFACT)		1	1	
Brake pads		if worn: 3		
Wheels/Tyres (*)	1	1	1	
Nut, bolt, screw tightening	1	1	1	
Cylinder synchronization	1		1	
Suspension and trim	1	1		1
Final drive (chain, rear and front sprocket)		1	1	
Fuel pipes			1	every 4 years: 3
Clutch wear		1		
Pistons		1		

2.1.3. TABLE OF LUBRICANTS

LUBRICANT	PRODUCT
Engine oil	RECOMMENDED:  EXTRA RAID 4, SAE 15W - 50 or  Agip TEC 4T, SAE 15W - 50. As an alternative to recommended oils, top brand oils meeting or exceeding CCMC G-4, A.P.I. S.G. specifications can be used.
RSV R fork oil	RECOMMENDED:  F.A. 5W,  F.A. 20W; as an alternative,  Agip FORK 5W or  Agip FORK 20W. When you wish to obtain an intermediate response between those offered by  F.A. 5W and  F.A. 20W oils or  Agip FORK 5W and  Agip FORK 20W, oils, you may mix the different products as follows: SAE 10W =  F.A. 5W 67% of volume +  F.A. 20W 33% of volume, or  Agip FORK 5W 67% del volume +  Agip FORK 20W 33% of volume. SAE 15W =  F.A. 5W 33% of volume +  F.A. 20W 67% of volume, or  Agip FORK 5W 33% of volume +  Agip FORK 20W 67% of volume.
RFACT (RSV R OPT) Fork oil type "R FACTORY"	ÖHLINS 5W
Bearings and other lubrication points	RECOMMENDED:  BIMOL GREASE 481 -  AUTOGREASE MP or  Agip GREASE 30. As an alternative to recommended grease, use top brand rolling bearing grease that will resist a temperature range of -30°C - +140°C, with dropping point 150°C - 230°C, high corrosion protection, good resistance to water and oxidation.
Battery lead protection	Use neutral grease or Vaseline.
Chains	Spray grease RECOMMENDED:  CHAIN SPRAY or  Agip CHAIN LUBE.
Brake fluid	RECOMMENDED: The system is filled with  Autofluid FR. DOT 4 (the braking system is also compatible with DOT 5);  Agip BRAKE 5.1 DOT 4 (the braking system is also compatible with DOT 5). NOTE Use new brake fluid only. Do not mix different makes or types of oil without having checked bases compatibility.
Clutch fluid	 F.F., DOT 5 (Compatibile DOT 4) ;  Agip BRAKE 5.1 DOT 5 (the braking system is also compatible with DOT 4). NOTE Use new clutch fluid only
Engine coolant	RECOMMENDED:  ECOBLU -40 °C -  Agip COOL. NOTE Use only nitrite-free anti-freeze and corrosion inhibitors with a freezing point of -35°C as a minimum.

2.1.4. TIGHTENING TORQUES

DESIGNATION	QUANTITY	SCREW / NUT	TORQUE (Nm)	NOTES
ENGINE				
Engine mounting to frame				
Front fitting	2+2	M10	50	-
Left side upper and lower rear fitting	2	M10	50	-
Adjuster bushing upper and lower rear fitting	2	M20x1,5	12	-
Locknut right side upper and lower rear fitting	2	M20x1,5	50	-
Screw right side upper and lower rear fitting	2	M10	50	-
Components mounted to engine				
Engine oil intake flange	2	M6	10	-
Engine oil outlet flange	2	M6	10	-
Rear brake lever mount	1	M6	10	-
Rear brake lever mount	1	M8	25	-
Rear brake pump mount	2	M8	25	-
Pinion mount	1	M10	50	Loctite 243
Clutch control cylinder mount	3	M6	10	-
Pinion cover mount	3	M6	10	-
Throttle body fuel delivery hose mount	1	M12x1,5	22	-
72/78 kW reduction bushing mount	1	M5	3±10%	Loctite 243
SWINGING ARM				
Swinging arm spindle nut	1	M30x1,5	60	-
Swinging arm spindle adjuster bushing	1	M30x1,5	12	-
Swinging arm spindle nut	1	M20x1,5	90	-
Calliper mount pin	1	M12	50	Loctite 243
Chain tensioner screw and nut	1+1	M8	man.	-
Rear brake hose bracket	3	M5	4	-
Chain cover	2	M5	4	-
Chain shoe	2	M5	3	-
Plastic chain guide	1	M5	3	-
Rear stand bushing	2	M6	10	-
Plastic chain shoe (nut)	1	M6	10	-
SIDE STAND				
Stand frame plate	1	M10	40	-
Side stand pin	1	M10x1,25	10	-
Switch screw	1	M6	10	Loctite 243
Locknut	1	M10x1,25	30	-

FRONT SUSPENSION				
Front fork				
Fork leg / top yoke	1+1	M8	25	-
Fork leg / bottom yoke mount	2+2	M8	25	-
Head stock nut (first tighten and then slacken off)	1	M35x1	40	first tighten and then slacken off
Head stock nut (second tighten down)	1	M35x1	20	second tighten down
Head stock locknut	1	M35x1	man. + 90 degrees	-
Top yoke cap	1	M29x1	100	-
SHOWA fork hub clamps	2+2	M8	22	-
OHLINS fork hub clamps	2+2	M6	12	-
Steering damper				
Steering damper collar frame	1	M6	10	Loctite 243
Steering damper rod bottom yoke	1	M6	10	-
REAR SUSPENSION				
Shock absorber				
Shock absorber frame	1	M10	50	-
Linkages				
Single connecting link frame	1	M10	50	-
Single / double connecting link	1	M10	50	-
Double connecting link swinging arm	1	M10	50	-
Double connecting link shock absorber	1	M10	50	-
ELECTRICAL SYSTEM				
Battery cover bracket	2	M5	2	-
Horn mount / bracket	1	M8	25	-
Odometer sensor rear brake calliper	1	M6	12	-
Rear direction indicators	2	M4	1	-
Front direction indicators / rear view mirror	2+2	M6	5	-
Voltage rectifier	2	M6	5	-
Coil bracket	1	M6	10	-
Tail light rear fairing end	4	M5	1	-
Head lamp front fairing	6	SWP5x14	2	-
Relay box seat subframe	2	M6	3	-
Relay cable starter motor	1	M6	5	-
Relay cable	2	M6	4	-
FRONT WHEEL				
Wheel axle nut	1	M25x1,5	80	-
REAR WHEEL				
Sprocket / sprocket carrier	5	M10	50	-
Wheel axle nut	1	M25x1,5	120	-

COOLING SYSTEM				
Fan mount	2+2	M6	6	-
Expansion reservoir frame	2	M6	5	-
Expansion reservoir cap	1	M28x3	man.	-
Hose clips (8104097)	-	-	3	-
BRAKE SYSTEM				
Front brakes				
Right and left brake callipers	2+2	M10x1,25	50	-
Brake fluid reservoir / bracket	1	M6	7	-
Brake fluid reservoir bracket / mount	1	M5	10	-
Brake disk	1	M8	30	-
Front brake three-way fitting bracket	6+6	M5	3	Loctite 243
Rear brakes				
Brake calliper	2	M8	25	-
Brake lever pin	1	M8	15	Loctite 243
Brake fluid reservoir	1	M5	1	-
Brake shaft locknut	1	M6	man.	-
Brake disk	5	M8	30	Loctite 243
Front brake hose three-way bracket	1	M5	3	-
EXHAUST SYSTEM				
Front exhaust hose / engine	4	M6	12	-
Rear exhaust hose / engine (upper screws)	2	M6	-	Hand fastening
Rear exhaust hose / engine (lower screws)	2	M6	12	-
Lambda sensor	1	M18x1,5	38	-
FUEL TANK				
Fuel pump flange				
Fuel return fitting	1	M6	6	Loctite 243
Pump mount / flange	3	M5	4	-
Electrical terminals / flange	2	M5	5	-
Fuel return cap	1	M6	10	Loctite 243
Fuel delivery hose / flange	1	M12x1,5	22	-
Fuel level sensor / pump mount	2	SWP2,9x12	1	-
Fuel pump cabling / flange	2	M6	10	-
Fuel tank				
Filler cap / tank	4	M5	5	-
Fuel pump flange / tank	8	M5	6	-

ENGINE OIL RESERVOIR			
Oil reservoir (nuts)	3	M6	10
Oil filter shank	1	M20x1,5	30
Oil drain cap	1	M8	15
Oil level bracket	2	M10x1	20
FRAME / FAIRING PANELS			
Front fairing / air scoop	1	M6	3
Windshield / front fairing	8	M4	1
Fairing / rider footplate and spacer	2+2	M6	4
Side fairing panel internal fitting / air dam	4	M5	3
Air dam / radiator mounts	2	M5	3
Front fairing panel / bottom yoke	3	M6	7
License plate holder / lower seat subframe cover	4	M6	3
Lower panel / seat subframe	3	M6	5
Front lower seat subframe panel / frame	2	M5	4
Side body panels / tank	1+1	M5	5
Side body panels / seat subframe	2+2	M5	3
Rear mudguard	4	M5	3
Front mudguard	4	M5	4
Rectangular reflector / license plate holder	2	M4	1
Stand bushing – lower panel / seat subframe	2	M6	12
Left/right side fairing	4	M5	3
Rear fairing /passenger seat subframe belt	2	M6	12
HANDLEBARS / CONTROLS			
Vibration damping weights	2	M6	10
Vibration damping weight terminals	2	M18x1	35
Handlebars / fork legs	2	M8	25
Handlebar safety screws	2	M6	10
Left dimmer switch	1	M5x1	1
Right dimmer switch	1	M4	1
Front brake pump	2	M6	8
Clutch pump	2	M6	8
Clutch reservoir / mount	1	M5	3
Rear fairing lock	2	M6	10
Seat subframe	4	M10	50
AIR BOX			
Airbox cover	7	SWP5x20	2
Airbox / throttle body	6	M6	7
Intake funnels	4	SWP3,9	1
MAP sensor mount	1	SWP5x20	2
Filter surround	2	SWP5x20	2
Air scoop / frame	4	M6	10
Rear view mirrors / air scoop	3+3	M5	5

2.1.5. SPECIAL TOOLS

In order to perform assembly, reassembly and settings correctly, special tools suitable for the task must be used. The use of special tools avoids the potential risk of damage as a result of inappropriate tools and/or improvised methods.

Below is a list of the special tools designed especially for this specific vehicle. If necessary, request the multi-purpose special tools.

 **CAUTION**
Before using the special tools, consult any documents attached.

SUPPORT STANDS

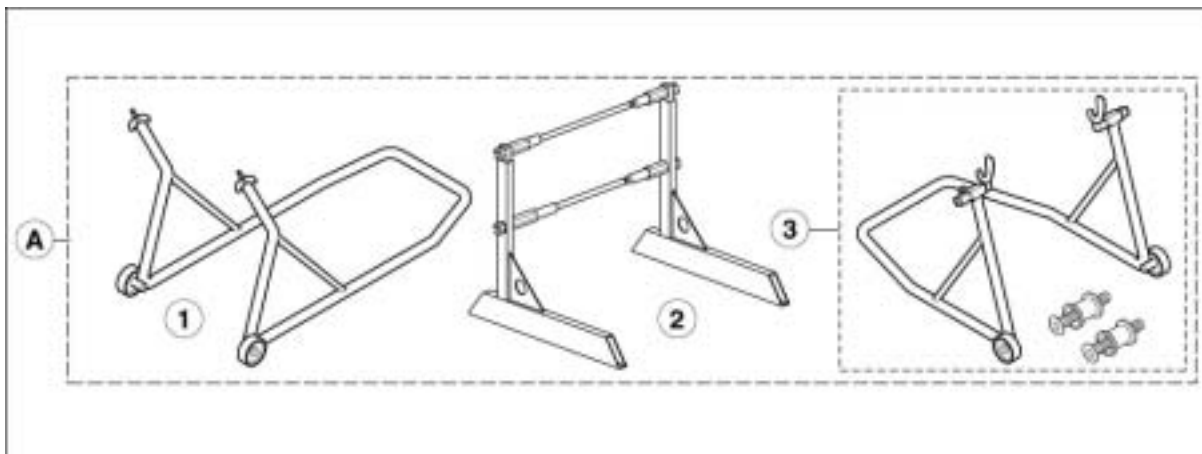

Pos.	aprilia part# (tool description and function)
A	8140176 (complete support stand kit)
1	8146486 (front support stand)
2	xxxxxxx N.A. [centre stand]
3	8705021 (rear support stand)

xxxxxxx N.A. = available only with the **aprilia** kit part# 8140176 (complete support stand kit)

FRAME TOOLS

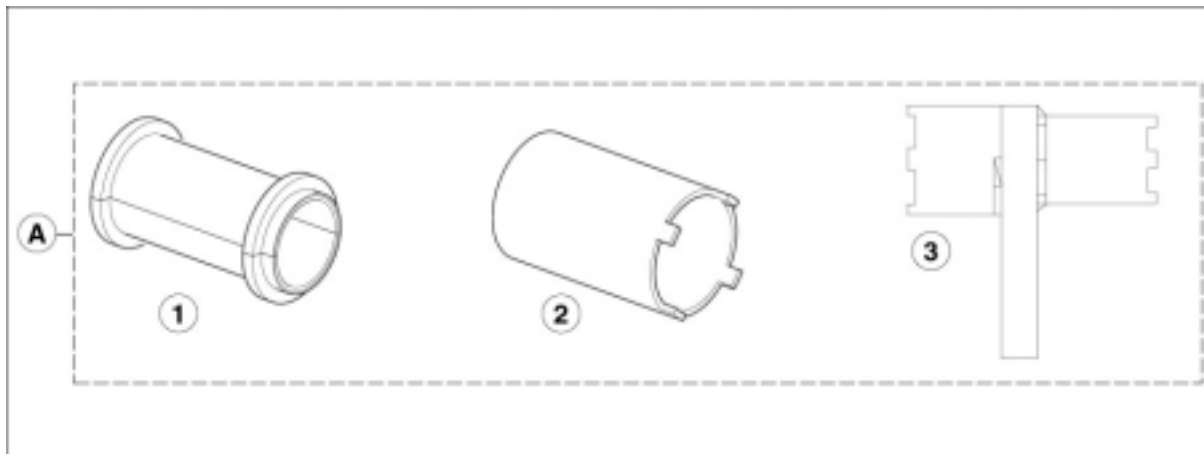

Pos.	aprilia part# (tool description and function)
A	8140203 (complete tool kit for frame including)
1	8140189 [oil seal fitting tool - Ø 43 hole. Kit accessory aprilia part# 8140151 (complete tool kit for fork including)]
2	8140190 (steering tightening tool)
3	8140191 (rear fork pin and engine support tightening tool)

FORK TOOLS

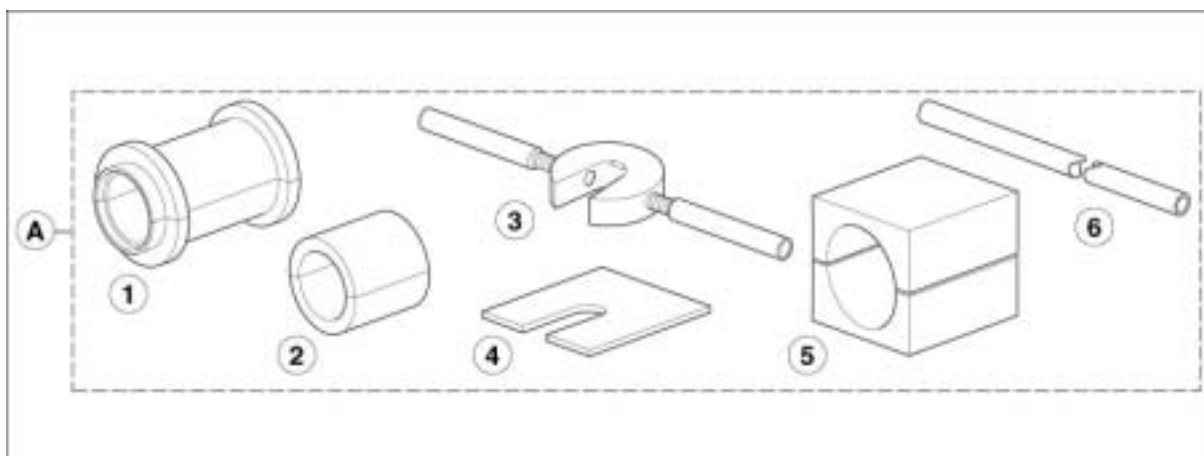

Pos.	aprilia part# (tool description and function)
A	8140151 (complete tool kit for fork including)
1	8140145 (Ø 41 mm sealing ring fitting tool)
2	8140146 [weight to be applied to the tool: aprilia part# 8140145 (Ø 41 mm sealing ring fitting tool)] e aprilia part# 8140189 [oil seal fitting tool - Ø 43 hole. Kit accessory aprilia part# 8140151 (complete tool kit for fork including)]
3	8140147 (spacer holding tool)
4	8140148 (spacer/pumping element separating plate)
5	8140149 (protection element for disassembly operations)
6	8140150 (drilled rod for pumping element bleeding)

ENGINE TOOLS

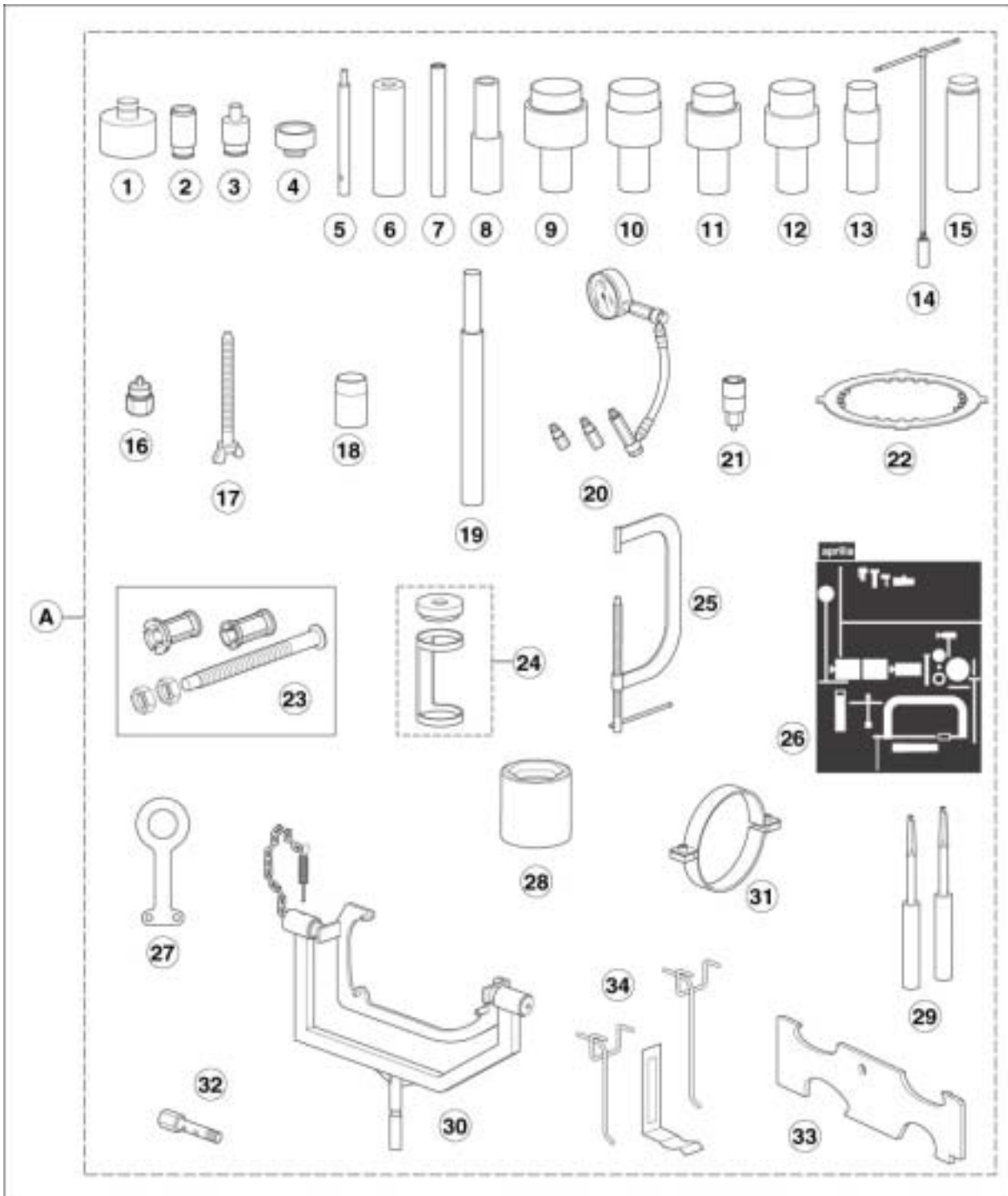

Pos.	aprilia part# (tool description and function)
A	8140175 (complete tool kit for engine including)
1	0277680 (gearshift secondary shaft oil seal assembly pad)
2	0277660 (upper countershaft oil seal assembly pad)
3	0277670 (coolant pump shaft housing oil seal assembly pad)
4	0877257 (assembly pad for water pump shaft seat sliding ring)
5	0277510 (valve guide disassembly pad)
6	0277210 (valve guide assembly)
7	0277695 (valve guide oil seal assembly pad)
8	8140155 (gearshift shaft oil seal - clutch shaft oil seal assembly pad)
9	0277725 (driving shaft bush inserter pad)
10	0277720 (driving shaft sleeve puller pad)
11	0277537 (lower countershaft bush inserter pad)
12	0277727 (driving shaft - clutch cover bush inserter pad)
13	0277729 (insertion pad for lower balance shaft clutch cover bushes)
14	8140177 (plug socket spanner)
15	0277252 (flywheel magneto cover removal tool)
16	0277730 (flywheel removal hexagonal bolt)
17	0240880 (threaded bolt to lock the drive shaft at the TDC)
18	0277308 (gearshift secondary shaft guide bush)
19	8140178 (pin installation and removal pad)
20	8140181 (fuel-oil pressure gauge-compression)
21	8140182 (rotor bolt bush)
22	0277881 (clutch blocking tool)
23	8140156 + 8140157 + 0276377 (clutch cover sleeve puller)
24	0276479 (valve spring compression tool)
25	8140179 (valves disassembly and reassembly bow)
26	8157143 (adhesive for tool holder panel RSVmille)
27	8140183 (engine lifting eye hook)
28	8140184 (primary transmission nut disassembly bush)
29	8140185 (clutch disc extraction hook lever)
30	8140188 (engine support)
31	8140186 (piston ring compression tool)
32	8140197 (perforated bolt for fuel pressure test fuel)
33	8140205 (camshaft template)
34	8140426 (panel hooks)

MISCELLANEOUS TOOLS

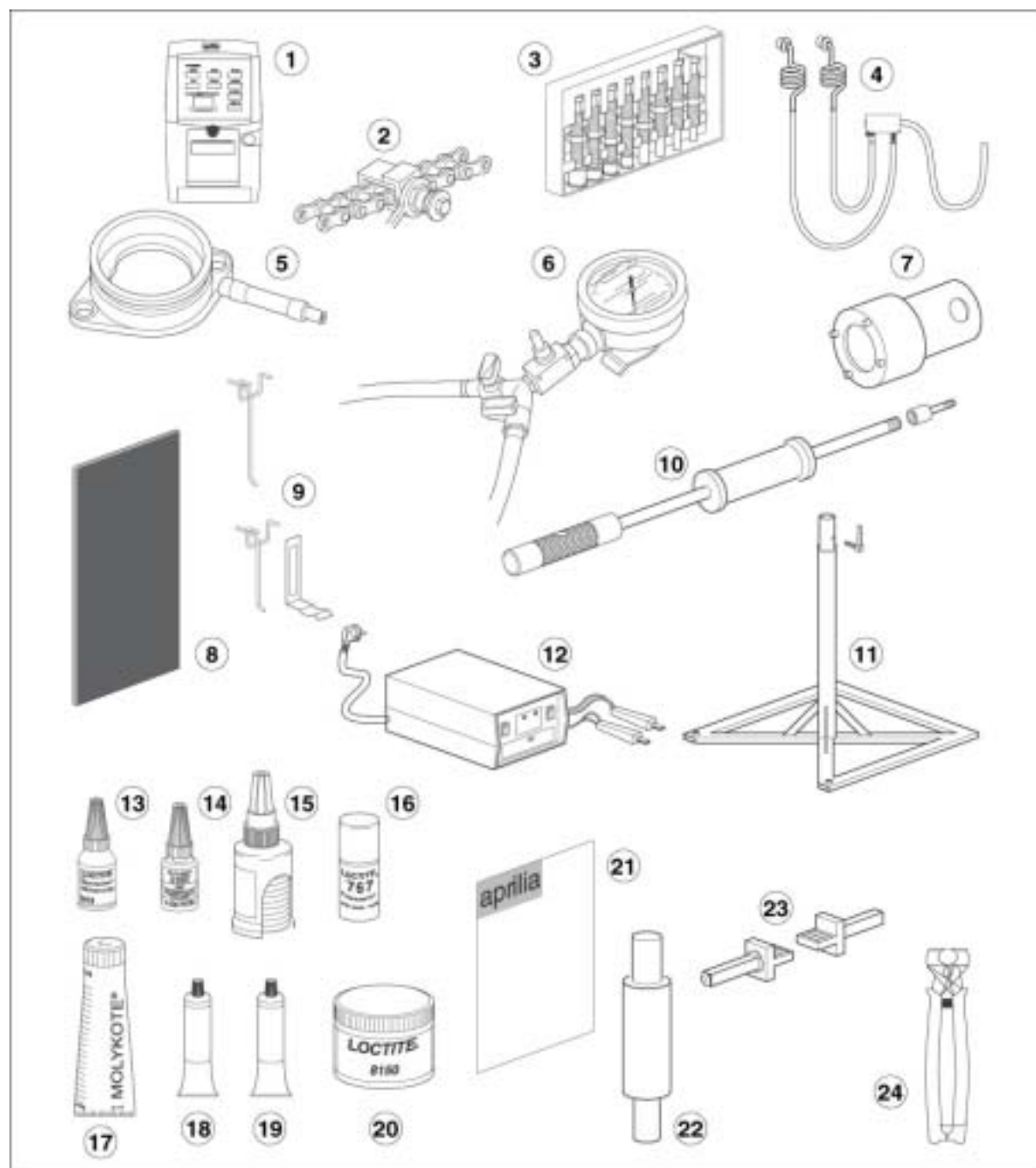

Pos.	aprilia part# (tool description and function)
1	8140196 [Plurigas (Italian)]
1	8140578 [Plurigas (English)]
2	8140192 (chain installation kit)
3	8140180 (bearing extractors)
4	8140202 (exhaust gas analysis probes)
5	8140267 (intake flange for vacuumeter)
6	8140256 (vacuometer)
7	8140424 (OHLINS fork spanner)
8	8140199 (tool panel)
9	8140426 (panel hooks)
10	8140432 (pushing extractor)
11	8140187 (engine support stand)
12	8124838 (battery charger M.F.)
13	0897651 [LOCTITE® 243 blue (10 cm ³)]
14	0899788 [LOCTITE® 648 green (5 g)]
15	0899784 (LOCTITE® 574 orange)
16	0297434 (LOCTITE® 767 Anti-Seize 15378)
17	0297433 [MOLYKOTE® G-N (50 g)]
18	0897330 (multi-purpose grease bp lz)
19	0297386 [SILASTIC 732 RTV (100 g)]
20	8116067 (LOCTITE® 8150)
21	8202222 (panel adhesive sheet)
22	8140074 (lower countershaft bush inserter pad)
23	8140204 (rear stand supports)
24	0277295 (hose clamp installation pliers)

TOOLS USED FOR OTHER aprilia

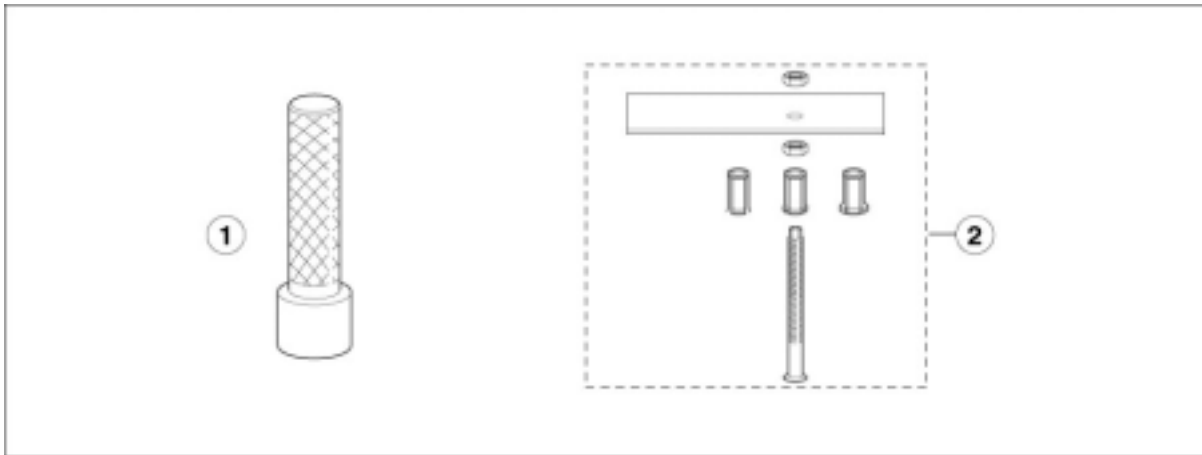

Pos.	aprilia part# (tool description and function)
1	0877650 (handle for pads)
2	0277265 (extractor for balance shaft, gearbox input and output shaft)
-	8116050 (engine oil)
-	8116053 (grease BIMOL GREASE 481 - AUTOGREASE MP or GREASE 30)
-	8116038 (grease LUBERING ST)
-	xxxxxxx N.A. (AP-LUBE temporary lubricant)
-	xxxxxxx N.A. (grease DID CHAIN LUBE)
-	8116031 (Fluid "Biosolvent" frame detergent)
-	8116945 ("ACRILICON 28" cyanoacrylic glue)
-	xxxxxxx N.A. (MOTUL MOTOWASH degreaser)
-	8116043 (ANTI-SEIZE MOTAGEPASTE AS 1800 antiscuff paste)
-	xxxxxxx N.A. (alcohol)
-	0898011 (fluorescent green LOCTITE® 275)
-	xxxxxxx N.A. (LOCTITE® 572)

xxxxxxx N.A. = not available

2.1.6. ARRANGEMENT OF THE MAIN ELEMENTS

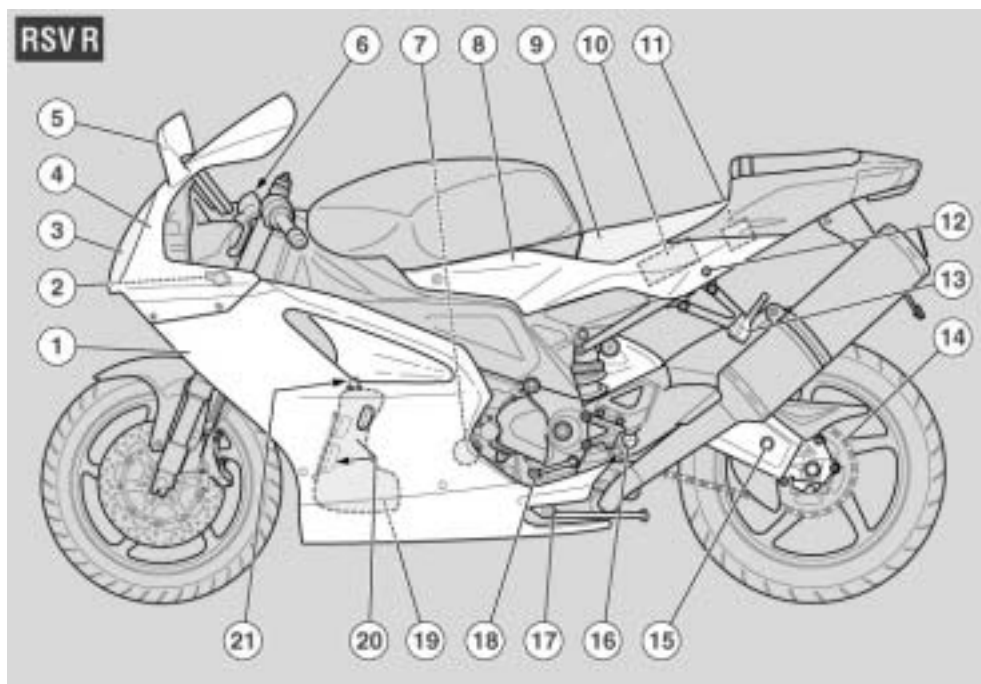
**KEY RSV R**

1. Left side fairing
2. Adjustable steering damper **RSV R OPT**
3. Headlight left lamp
4. Front fairing
5. Left rear-view mirror
6. Clutch fluid reservoir
7. Engine oil filter
8. Left side panel
9. Rider seat
10. Battery
11. Main fuse carrier (30 A)
12. Passenger seat lock glove/tool kit compartment
13. Passenger left footrest (snaps closed/open)
14. Drive chain
15. Rear swinging arm
16. Rider left footrest
17. Side stand
18. Gear shift lever
19. Engine oil tank
20. Engine oil level
21. Engine oil tank cap

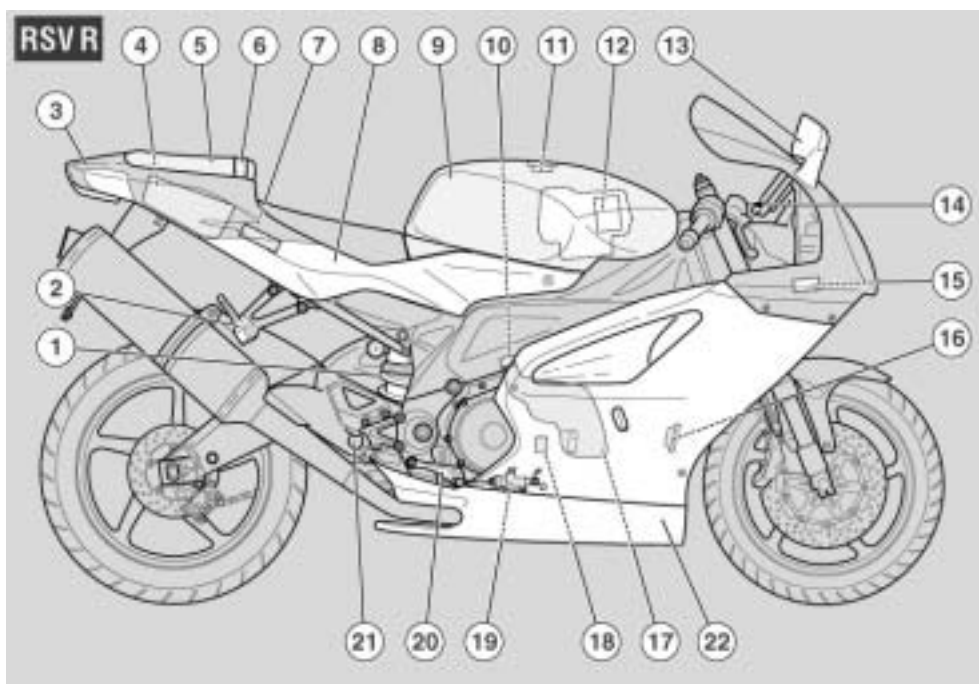
**KEY RSV R**

1. Rear shock absorber
2. Passenger right footrest (snaps closed/open)
3. Tail light
4. Glove/tool kit compartment
5. Passenger seat (glove/tool kit compartment cover)
6. Passenger grab strap
7. Engine Control Unit
8. Right side panel
9. Fuel tank
10. Coolant expansion tank cap
11. Fuel tank filler cap
12. Air cleaner
13. Right rear-view mirror
14. Front brake fluid reservoir
15. Secondary fuse carrier (15 A)
16. Horn
17. Right side fairing
18. Expansion tank
19. Rear brake fluid reservoir
20. Rear brake master cylinder
21. Rear brake lever
22. Rider right footrest

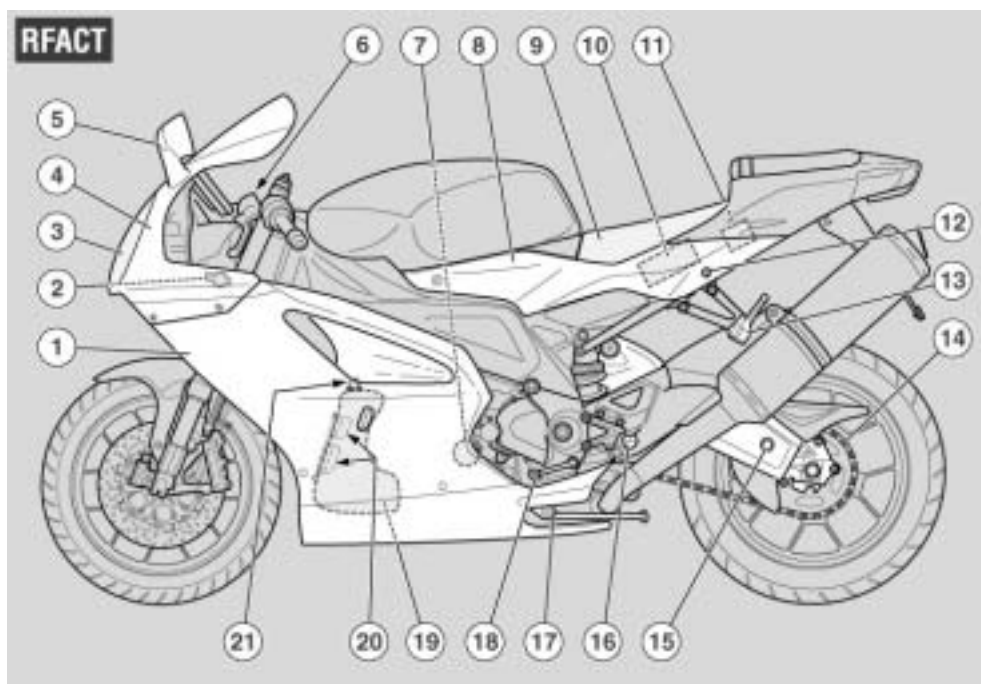
**KEY RFACT**

1. Left side fairing
2. Adjustable steering damper
3. Headlight left lamp
4. Front fairing
5. Left rear-view mirror
6. Clutch fluid reservoir
7. Engine oil filter
8. Left side panel
9. Rider seat
10. Battery
11. Main fuse carrier (30A)
12. Passenger seat-Glove/tool kit compartment lock
13. Passenger left footrest
14. Drive chain
15. Rear swinging arm
16. Rider left footrest
17. Side stand
18. Gear shift lever
19. Engine oil tank
20. Engine oil level
21. Engine oil tank cap

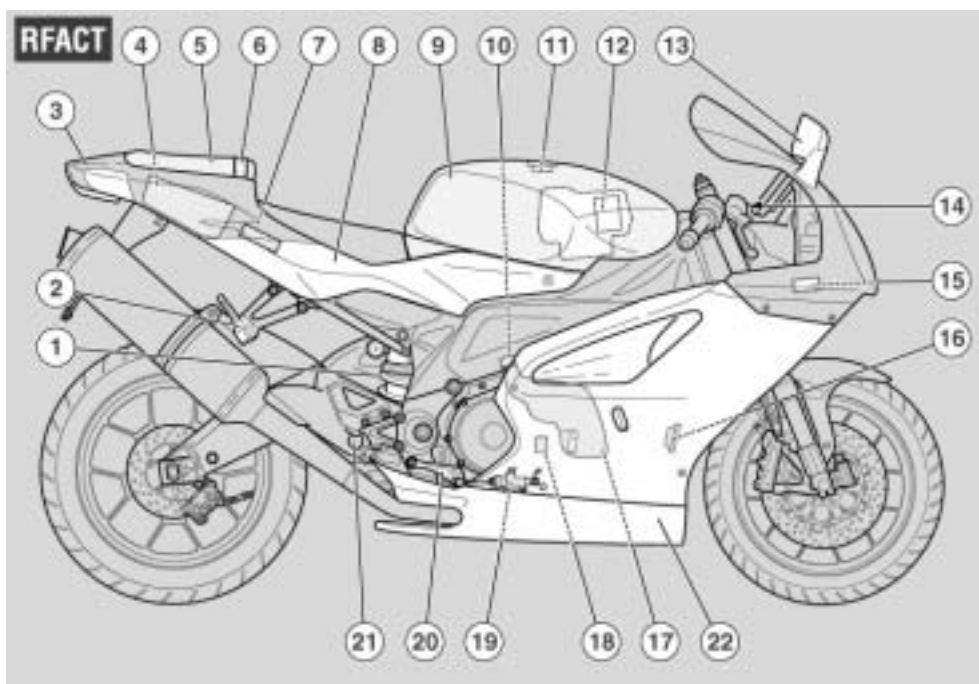
**KEY RFACT**

1. Rear shock absorber
2. Passenger right footrest (snaps closed/open)
3. Tail light
4. Glove/tool kit compartment
5. Passenger seat (Glove/tool kit compartment cover)
6. Passenger grab strap
7. Engine Control Unit
8. Right side panel
9. Fuel tank
10. Coolant expansion tank cap
11. Fuel tank filler cap
12. Air cleaner
13. Right rear-view mirror
14. Front brake fluid reservoir
15. Secondary fuse carrier (15A)
16. Horn
17. Right side fairing
18. Coolant expansion tank
19. Rear brake fluid reservoir
20. Rear brake master cylinder
21. Rear brake lever
22. Rider right footrest

2.1.7. ARRANGEMENT OF THE INSTRUMENTS/CONTROLS

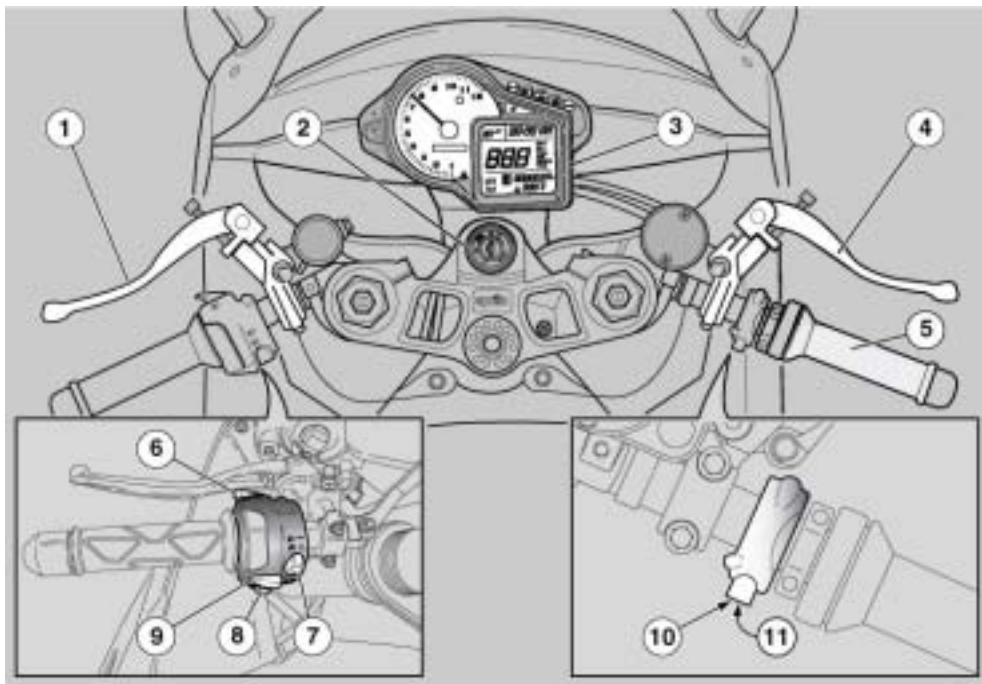

Key:

1. Clutch lever
2. Ignition/steering lock switch (🔑 - 🔒 - 🔓)
3. Instruments and indicators
4. Front brake lever
5. Throttle twistgrip
6. High beam flasher (🔴)/LAP button (multifunction)
7. Light dimmer switch (🔴 - 🔵)
8. Direction indicator switch (↔)
9. Horn button (🔊)
10. Starter button (🔌)
11. Engine kill switch (🛑 - 🛑)

Key:

1. Rev counter
2. Red line light
3. Green direction indicator light (↔)
4. Blue high beam light (🔵)
5. Amber "stand down" light (🟡)
6. Amber low fuel light (🟡)
7. Red immobilizer light (🔴) (where immobilizer system is fitted)
8. Green neutral light (N)
9. Multifunction digital display (coolant temperature - clock - battery voltage - lap timer - engine oil pressure diagnostics (🔧))
10. Red general warning light (🔴)
11. Multifunction computer programming buttons (+, Trip V, -)

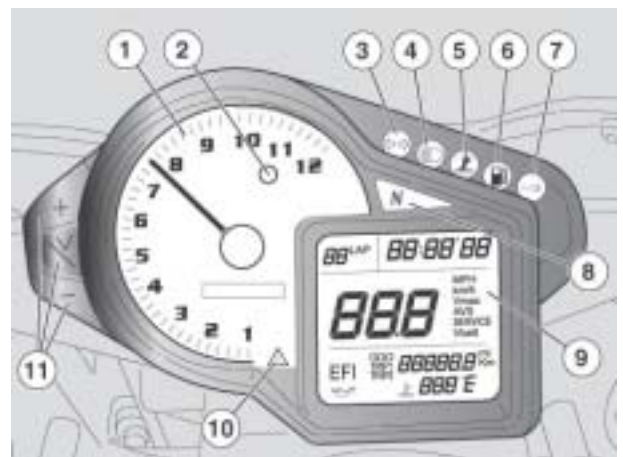

2.1.8. DASHBOARD OPERATION

When the ignition key is turned to "I", the following will light up on the dashboard for 3 seconds:

- all segments of the multifunction display
- all indicator leds
- display backlighting

The revolution counter pointer (1) will move to the maximum rpm set by the user.

After 3 seconds the red line led (2) will turn off and the revolution counter pointer (1) will return to its initial position.

After the initial self-test all instruments will indicate their real-time current values.

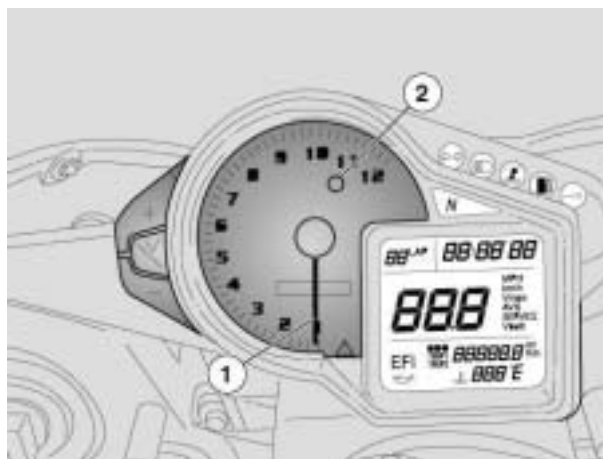

WARNING

If "ERR" flashes on the dashboard instead of the water temperature reading and the stand and red line leds turn on, then there is a communications problem on the can line between the dashboard and the ECU.

After the first 1000 km, the SERVICE icon will be displayed on the multifunction display. It will be displayed for a second time after 10,000 km, and every 10,000 km thereafter.

To reset the SERVICE message, hold down the + and - keys for at least 15 seconds at key-ON.

When the ignition key is turned to "I" the standard display settings are:

- current speed
- clock
- coolant temperature
- odometer



METRIC SYSTEM DISPLAY (km-mi, kph-MPH, °C-°F)

- To switch between km/mi, kph/mph, hold down the TRIP/V and - keys for at least 15 seconds.
- To switch between °C and °F hold down the TRIP/V and + keys for at least 15 seconds.

RSV 1000 R - RSV 1000 R FACTORY

CURRENT/MAX/AVERAGE SPEED AND BATTERY VOLTAGE DISPLAY

IMPORTANT The average/max speed and battery voltage are only displayed with the vehicle stationary. Only the current speed is displayed when the vehicle is being driven.

When the ignition key is turned to "I" the current speed is displayed. To display the max speed (V max), average speed (AVS) and battery voltage, press the + key.

To reset the max speed (V max) and average speed (AVS), press the – key for at least 3 seconds while the values are being displayed.

IMPORTANT The max and average speed readings refer to the period since they were last reset.

The battery voltage reading (V) is not modifiable and gives information on the operating condition of the battery.

The recharger circuit is operating correctly if the battery voltage reads 13 to 15 V with the head lamp set to low beam and the engine running at 4000 rpm.

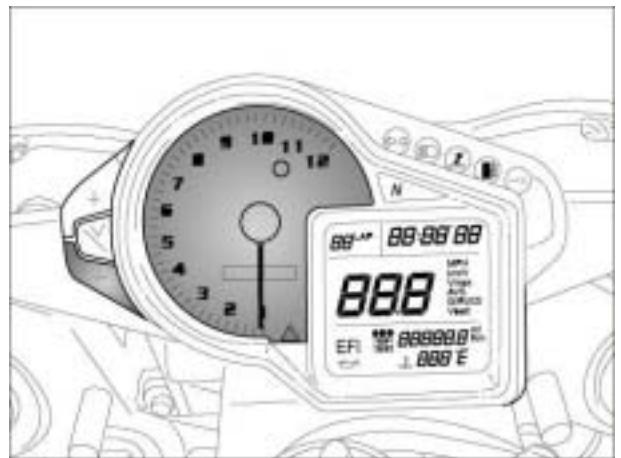

Instruments lighting adjustment : The dashboard backlighting can be adjusted to three levels (30%, 70%, 100%); this is done by pressing the – key during the first 5 seconds after the ignition key has been turned to "I".

**TOTAL AND PARTIAL (TRIP 1 / 2) ODOMETER DISPLAYS**

When the ignition key is turned to "I" the odometer is displayed. To display the partial odometer readings (TRIP 1 / 2), press the TRIP/V key.



To reset partial odometer 1 (TRIP 1) display the reading and hold down the TRIP/V key for at least 3 seconds.



To reset partial odometer 2 (TRIP 2) display the reading and hold down the TRIP/V key for at least 3 seconds.

IMPORTANT The partial odometer readings refer to the period since they were last reset.

- The partial odometer readings (TRIP 1 / 2) are reset when the battery is disconnected from the vehicle.



DISPLAY : COOLANT TEMPERATURE

- The coolant temperature display reads “---” when the sensor reads a temperature below 34°C (93°F).
- The current temperature reading is displayed without flashing when the sensor reads a temperature between 35°C (95°F) and 114°C (237°F);
- The display flashes when the reading is between 115° C (239° F) and 135°C (275°F). The warning led also lights up to indicate that the temperature is in the danger zone.
- The display will flash 135°C (275°F) if the temperature exceeds this value (with warning led on).



WARNING

If the coolant temperature sensor is disconnected or damaged the dashboard error led turns on (▲) and the coolant temperature is not read.

Thermometer range : 35-135°C (95-275 °F).

SETTING THE DIGITAL CLOCK

The digital clock is at the top of the display.

The clock displays only when the ignition key is turned to .

IMPORTANT The clock can be set only with the vehicle stationary and the ignition key turned to .

HOURS SETTING

- Hold down the + and – keys for at least 3 seconds so that the hour digits start to flash.
- Use the + and – keys to set the hour.
- If one of the keys is held down the setting will run through the hours one a second.
- Hold down the TRIP/V key for at least 3 seconds to confirm the new setting. The clock will automatically move to the minutes setting mode.



MINUTES SETTING

- Press the + or – key to increase/decrease the minute setting. If one of the keys is held down the setting runs through the minutes one a second.
- Hold down the TRIP/V key for at least 3 seconds, at which point the minute digits will stop flashing to indicate that the new setting is confirmed.
- The clock setting is lost when the battery is disconnected from the vehicle.

CHRONOMETER

The chronometer measures the lap time when driving on track and stores the data for later reference.

When the chronometer is enabled, the clock function is excluded.

To activate the chronometer :

- Hold down the LAP button and press TRIP/V for more than 3 seconds. The clock display will be replaced by "01 LAP 00'00"00".

To de-activate the chronometer :

- Hold down the LAP button and press TRIP/V for more than 3 seconds. The clock display will return.

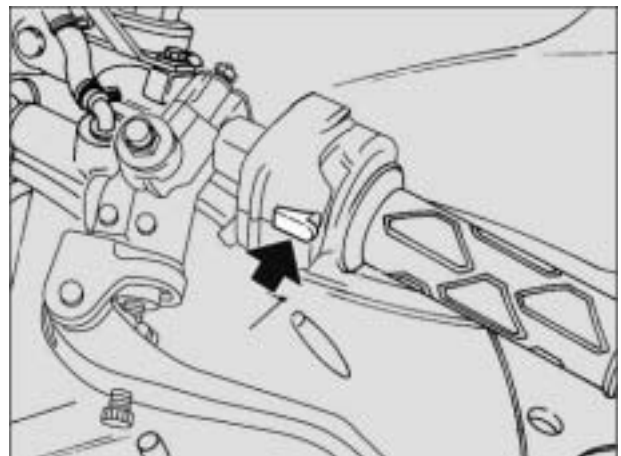

To start the chronometer :

- press and immediately release the LAP button. The first time the button is pressed starts the stop clock. Pressing LAP again within the first 10 seconds will reset the chronometer. Pressing the LAP button again starts a new lap ; the previous lap time and number are displayed for 10 seconds at the top left of the display. At the end of the 10 seconds the chronometer will display the second lap time and number.

IMPORTANT Up to 40 laps can be stored; pressing the LAP button after this does not start a new lap and the display will automatically show the 40 stored lap times. To reset the chronometer function the 40 stored laps must be reset.

- To reset a stored time, enable the chronometer. With the LAP button held down, press the – key for at least 3 seconds.
- The display will read “Ø1 LAP ØØ’ ØØ” ØØ ” to indicate that all 40 stored laps have been set to zero.
- Stored lap times are zeroed when the battery is disconnected from the vehicle.

To display the stored lap times :

- Enable the chronometer function and hold down TRIP/V for more than 3 seconds. To scroll through the laps, press the +/- keys (forwards/back respectively).
- To return to the chronometer function, press TRIP/V again for more than 3 seconds.

DIAGNOSTICS

Whenever the ignition key is turned to “”, “EFI” is displayed for 3 seconds.



WARNING

If “EFI” displays together with the warning led () while the engine is running normally, the ECU has detected a fault. In most cases the engine will continue to operate, although with reduced performance.



ENGINE OIL PRESSURE

Whenever the ignition key is turned to “”, the engine oil pressure led turns on for 3 seconds.



WARNING

If the engine oil pressure icon stays on together with the warning led () after starting, or if it turns on while the engine is running normally, the engine oil pressure is insufficient. In this case, stop the engine immediately.



RED LINE ADJUSTMENT (ONLY WITH ENGINE OFF)

When the engine rpm exceeds the red line setting, the red line indicator (2) on the dashboard flashes.

IMPORTANT The red line setting can only be adjusted with the engine off and the odometer displayed (adjustment range 2000 to 12000 rpm).

The default value is 6000 rpm.

To display the red line setting, hold down TRIP/V for at least 3 seconds. The revolution counter pointer (1) will move to the set red line value.

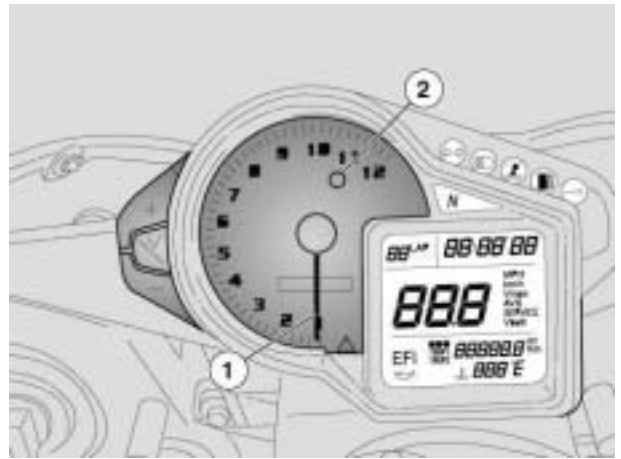
**To adjust :**

- Turn the ignition key to "I".
 - Wait for the self-check to complete.
 - Press TRIP/V for more than 3 seconds: the revolution counter pointer (1) will move to the set red line value.
 - The red line setting can be adjusted during the 3 seconds that the revolution counter pointer (1) is indicating the set value.
 - Adjust the red line setting with the + key : pressing it briefly will increase the setting by 100 rpm ; holding it down will increase it by 1000 rpm.
 - If the pointer reaches the full scale value (12000 rpm) it is automatically reset to zero.
-
- 3 seconds after the last adjustment (+ key) the new red line setting is stored and confirmed by the red line indicator (2) turning on for 3 seconds. The pointer (1) returns to zero.
 - If the engine is started during the adjustment procedure, the previous setting is maintained. The setting is lost if the battery is disconnected during the adjustment procedure, and the previous setting is maintained.

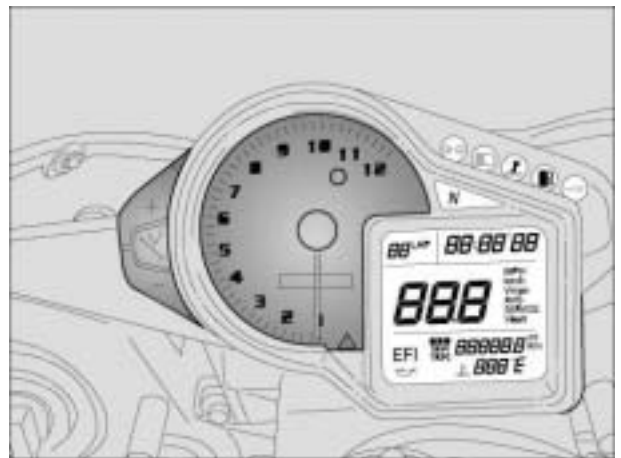
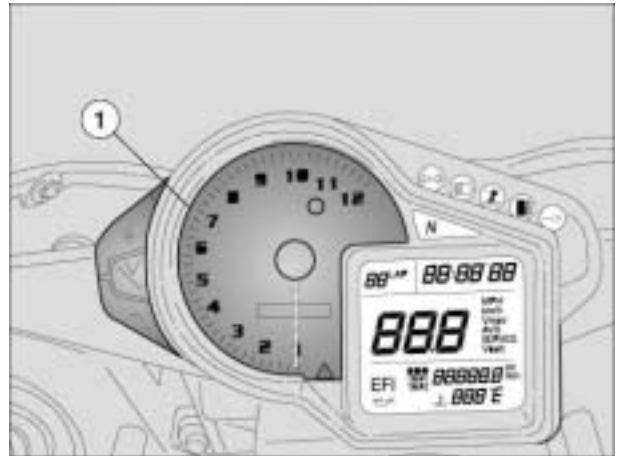
**DASHBOARD ECU DIAGNOSTICS CODE DISPLAY**

Display type :

water temperature digits together with EFI icon and warning led (▲). When a diagnostics code is displayed, the water temperature symbol (thermometer), units indication (°C/°F) and display segments disappear.

Operating modes :

In normal conditions the "EFI" icon and warning led (▲) are off. if the ECU sends one or more Fault Codes to the dashboard the dashboard will not display them, but will only turn on the warning led (▲) and "EFI" icon.

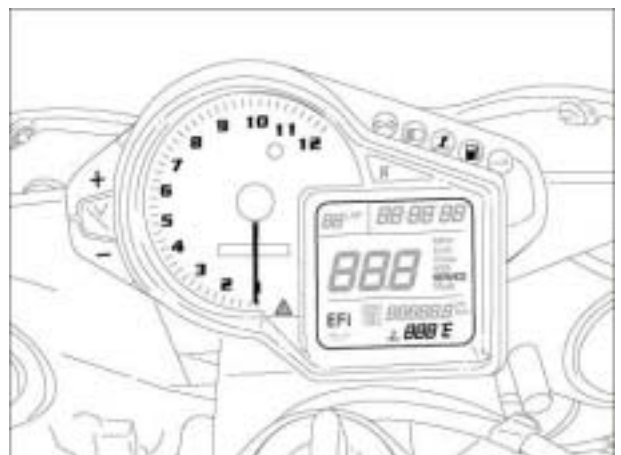

To display the diagnostics codes in question, enable diagnostics mode by pressing the LAP button at key-ON for at least 15 seconds. To exit the diagnostics code display and return to the normal display mode, run a key-OFF/ON cycle. When the faults are eliminated and hence the Fault Code is no longer being sent to the dashboard by the ECU, the dashboard will continue to display them until a key-OFF/ON cycle is run.

If the dashboard is sent a code other than those given in the following diagnostics code table, it will display PXX where the XX is the last two digits of the code in question. If the CAN line does not respond or is disconnected in diagnostics mode, ERR will flash in place of the code digits.

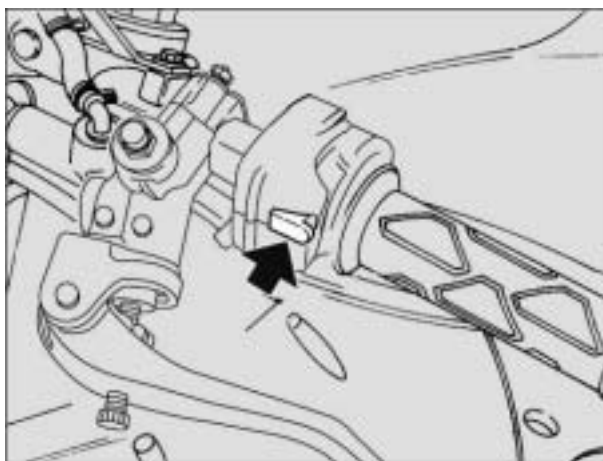

DIAGNOSTICS CODE TABLE

Error Type	Error type	Aprilia Code
NO error	-	-
Cam Sensor	No signal	11
Crank Sensor	No signal	12
	Faulty signal	
MAP Sensor	Sensor fault	13
	Signal < V	
	Signal > V	
TPS	Sensor voltage < V	15
	Sensor voltage > V	
	Sensor fault	
	Sensor not adapted	
Engine temperature	Sensor fault	21
	Sensor voltage < V	
	Sensor voltage > V	
Air temperature	Sensor fault	22
	Sensor voltage < V	
	Sensor voltage > V	
Barometric pressure	Sensor voltage < V	23
	Sensor voltage > V	
Ignition #1	Ignition signal 1 not present	33
Ignition #2	Ignition signal 2 not present	35
Tip Over Switch	Sensor fault / disconnected	41
Injector #1	Injector 1 short circuit / open	42
	Injector 1 short circuit with battery +V	
Injector #2	Injector 2 short circuit / open	43
	Injector 2 short circuit with battery +V	
Stepper motor	Output fault	44
	Output fault	
Fuel Pump	Pump short circuit / open	45
	Pump in short circuit with battery +V	
Lambda	Sensor voltage </> V or faulty sensor	46
	Sensor short circuit / open / short circuit with battery +V	
	Sensor not adapted	
Oil pressure	Sensor fault	47
Engine fan relay	Fan relay short circuit / open / short circuit with battery +V	48
Tank purge valve	Valve short circuit / open / short circuit with battery +V	49
Starter	Starter short circuit / open	50
	Starter short circuit with battery +V	
Battery voltage	Battery voltage < V	51
	Battery voltage < V	

SERVICE INTERVALS

Display type : SERVICE icon

Operating modes : the SERVICE icon displays

- after the first 1000 km (620 mi) \pm 5%;
- next after a total 10000 km (6213 mi), i.e. 9000 km (5592mi) after the first time,
- every 10000 km (6213 mi) \pm 5% thereafter, hence at 20000 km (12427 mi); 30000 km (18641 mi), etc...

To reset the « SERVICE » function, hold down the + and – keys together for at least 15 seconds at key-ON.

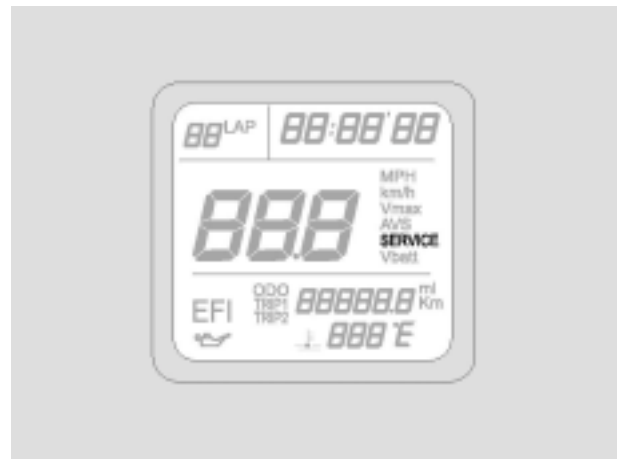

2.1.9. SYSTEMS DIAGRAM

BRAKES

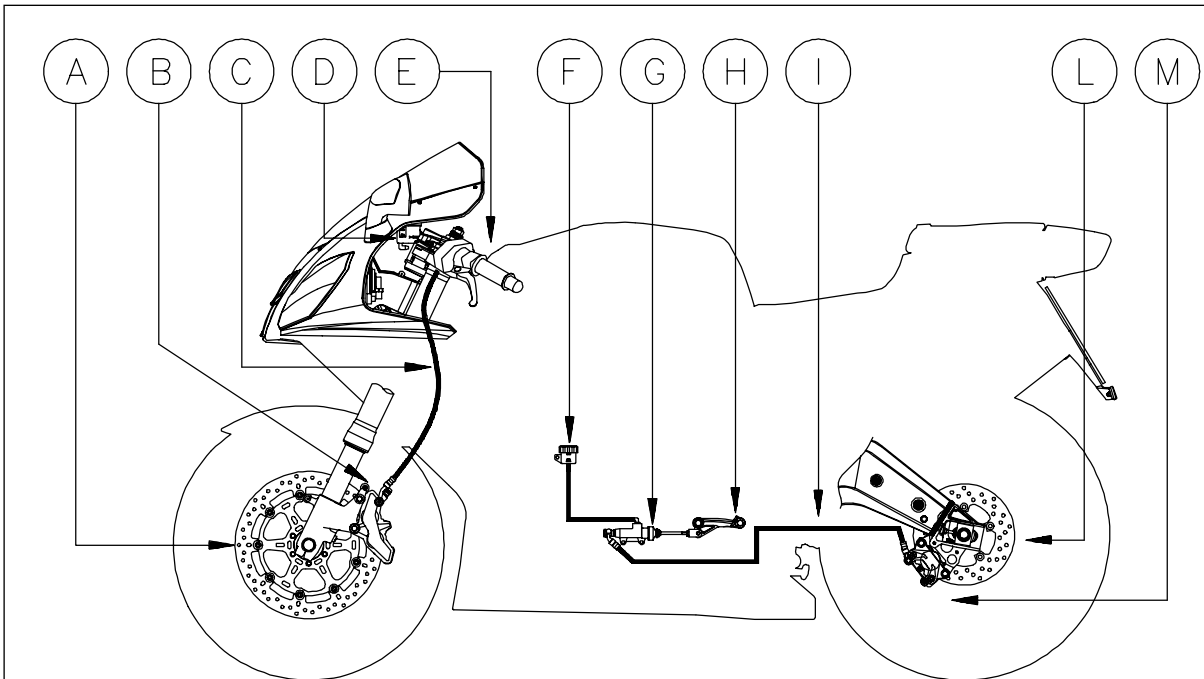

POS.	DESCRIPTION	POS.	DESCRIPTION
A	FRONT BRAKE DISK TWO	F	REAR BRAKE OIL SUPPLY TANK (RIGHT SIDE)
B	FRONT CALIPER	G	REAR BRAKE PUMP (RIGHT SIDE)
C	FRONT OIL PIPE	H	REAR BRAKE LEVER (RIGHT SIDE)
D	FRONT BRAKE OIL SUPPLY TANK	I	REAR BRAKE PIPE
E	FRONT BRAKE PUMP WITH LEVER (RIGHT SIDE)	L	REAR BRAKE DISK (RIGHT SIDE)
		M	REAR CALIPER

GAS RECOVERY FROM CRANKCASE

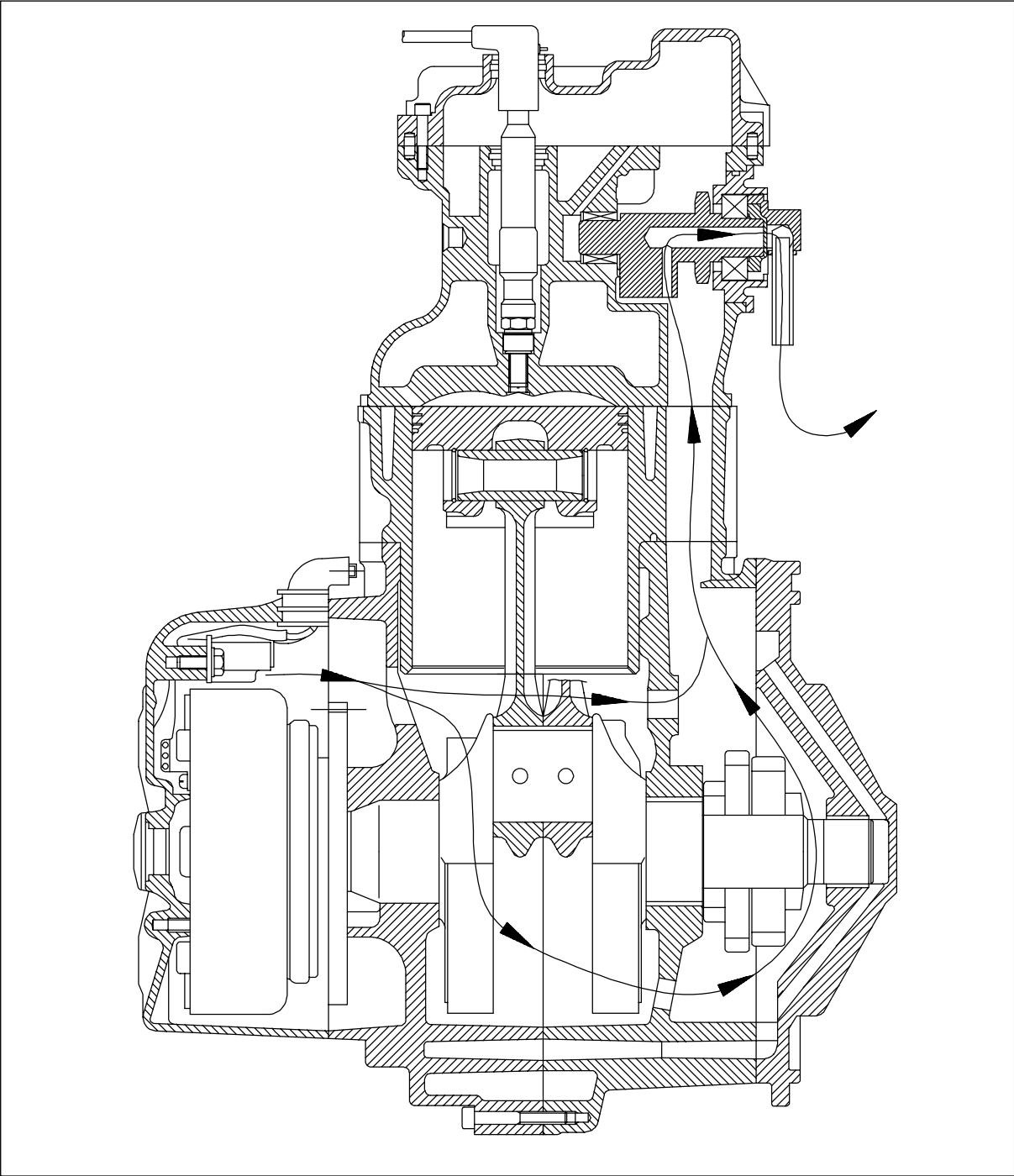

FUEL SYSTEM

3

SUMMARY

3.1. FUEL SYSTEM..... 3

 3.1.1. DIAGRAM 3

 3.1.2. INJECTION SYSTEM DIAGRAM..... 4

 3.1.3. CYLINDER TIMING AND CO LEVEL ADJUSTMENT..... 6

 3.1.4. AXONE..... 7

 3.1.5. AIRBOX..... 11

3.2. FUEL PUMP 12

 3.2.1. REMOVING THE FUEL PUMP ASSEMBLY 12

 3.2.2. REMOVING THE FUEL LEVEL SENSOR 13

 3.2.3. REMOVING THE DELIVERY FILTER..... 14

 3.2.4. REMOVING THE FUEL SUPPLY PUMP 15

3.3. THROTTLE BODY..... 17

 3.3.1. REMOVING THE THROTTLE BODY..... 17

 3.3.2. DISASSEMBLING THE THROTTLE BODY 20

 3.3.3. INSPECTING THE THROTTLE BODY 23

 3.3.4. REFITTING THE THROTTLE BODY 24

 3.3.5. REPLACING THE THROTTLE VALVE CONTROL LEVER..... 26

 3.3.6. CHECKING THROTTLE VALVE CONTROL SHAFT END PLAY 27

3.1. FUEL SYSTEM

3.1.1. DIAGRAM

**Key**

- 1) Fuel tank
- 2) Filler cap
- 3) Fuel supply pump unit
- 4) Fuel vapour breather pipe (for the vapours produced by excessive pressure inside the tank)
- 5) Fuel "overflow" drainage pipe
- 6) Fuel level sensor
- 7) Fuel delivery filter
- 8) Fuel supply pump
- 9) Fuel delivery pipe
- 10) Fuel return pipe

3.1.2. INJECTION SYSTEM DIAGRAM

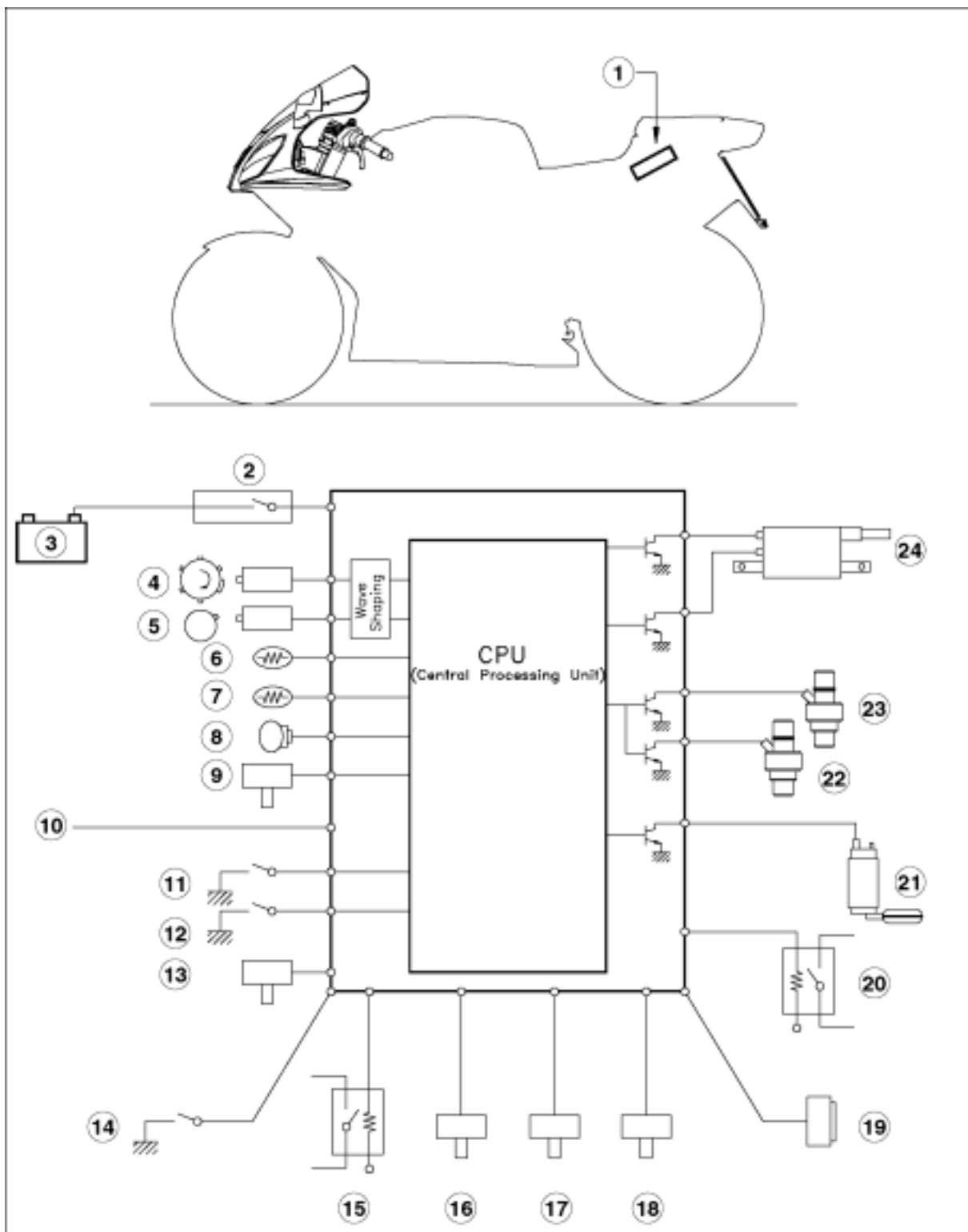

Legend :

1. ECU location
2. Ignition switch
3. Battery
4. Engine shaft position sensor
5. Camshaft position sensor
6. Engine temperature sensor
7. Air temperature sensor
8. Throttle position sensor
9. Intake pressure sensor
10. Safety system : Side stand, idle sensor
11. Test switch
12. Fall sensor
13. Atmospheric pressure sensor
14. Oil pressure sensor
15. Fan
16. Automatic air
17. Intake flap
18. Lambda sensor
19. Diagnostics connector
20. Starter relay
21. Fuel pump
22. Injector 1
23. Injector 2
24. Coil

3.1.3. CYLINDER TIMING AND CO LEVEL ADJUSTMENT

- With the vehicle switched off, connect the Axone 2000 to the diagnostics connector and the vehicle's battery.
- Switch on the instrument.



- Connect the exhaust gas analyser lines to their fittings.

- Start with both throttle body bypass screws fully closed.
- Open a single screw to balance the exhaust gas CO level, as read off the analyser display.









- Read the front and rear cylinder pressure values off the Axone, and check that they are as follows :
front cylinder pressure = rear cylinder pressure – (30 ± 10) mbar

IMPORTANT Incorrect pressure value readings indicate a possible malfunction.



3.1.4. AXONE

ICON	DISPLAY
	ISO
	ENGINE PARAMETER READING
	DEVICE STATUS (generally on/off)
	DEVICE ACTIVATION
	ERRORS DISPLAY
	ADJUSTABLE PARAMETERS

DISPLAY	DESCRIPTION	VALUES (APPROXIMATE)	UNITS OF MEASUREMENT	NOTES
ISO	Aprilia hardware			
	Aprilia software			
	Revision number			
	Engine			
	Manufactured			
	Mapping			Indicates the ECU mapping code
	Date programmed			Most recent mapping date
	Last author			ID of PC/Axone which loaded the most recent mapping
ENGINE PARAMETER READING	Water temperature		°C	Fans are activated at 101°C
	Air temperature		°C	
	Engine speed		rpm	
	Target minimum engine speed		rpm	ECU target engine speed for current operating conditions
	Engine load		-	
	Intake pressure		hPa	Value read by sensor connected to the two intake ducts
	Effective throttle aperture	2,7-80	°	Parameter which accounts for the throttle aperture and stepper motor position
	Spark advance		°	
	Throttle	0-78°	°	Reads the throttle aperture in degrees
	Throttle offset	approx. 0,60- 0,63	V	Reference after reset (ECU stored value)
	Idling control stepper motor		-	Steps of idling control motor
	Battery voltage		V	
	Vehicle speed		kph	
	Cylinder pressure (front)		hPa	Intake duct pressure
	Cylinder pressure (rear)		hPa	Intake duct pressure
Lambda correction		-	Approx. 1 with lambda sensor active	

	Lambda sensor		mV	Value ranges from 300 to 3000 mV
	Type 1 carburettor adjustment		-	Tells the ECU how much air is required in the type 1 engine load condition
	Type 2 carburettor adjustment		-	Tells the ECU how much air is required in the type 2 engine load condition
	Idling carburettor adjustment		-	Tells the ECU how much air is required in the idling engine load condition
	Injection time		ms	
	Atmospheric pressure		hPa	Sensor located under seat
	Spark advance		°	
DEVICE STATUS	Fall sensor	normal/ tip over		
	ECU	valid/invalid combination		The ECU supplies the valid combination signal to the dashboard when it is installed on a compatible vehicle
	Oil pressure	low/ normal		
	Idling condition	on/off		Engine condition at idling (see also with engine off)
	Full load	on/off		Engine condition under full load (engine must be on)
	Engine kill button	on/off		Engine kill button status
	Ignition request	on/off		Thus can be seen with the gear engaged by pressing the starter button : in this condition the ECU reads the ignition permissive (Axone reads ON) but does not start the engine. For instance, if the right dimmer switch circuit is interrupted, although the ignition button is pressed, the condition of this parameter does not change (it stays OFF)
	Purge valve	on/off		
	Lambda sensor active	on/off		Lambda sensor operational
	Cut off	on/off		Activates at certain engine speed / throttle position etc. combinations
	Throttle self-teaching completed	on/off		If throttle position self-teaching does not terminate successfully, the parameter = OFF
	Engine heating phase	on/off		
	Power latch completed	on/off		When power to the ECU is switched off, a series of parameters is stored during the power latch
	Reduced operation	on/off		In case of serious engine malfunction it will be run at only less than a set engine speed
	Gear in neutral	yes/no		
	Switch	on/off		Parameter not assigned
	Side stand	up/down		
	Clutch engaged	yes/no		
	Initialisation error	no / engine speed >0 / vehicle speed >0 / stepper error / throttle out of range / battery voltage / water temperature / idling control motor off		List of the potential reasons why the throttle self-teaching or initialisation failed
	Purge valve status	lambda on / threshold not reached / Cut off active / rpm threshold / speed / Injector defect / HW cut off / not active		Purge valve related reasons why the lambda sensor does not activate ; only for CALIFORNIA version, check operation

	Lambda sensor	initialisation / wait after start / sensor status recognition / wait after recognition / de-activated due to driving / de-activated due to fault / wait after interruption / lambda sensor active / saturated	Lambda sensor status
	Long term adjustment de-activation	no / max tries / water temperature over threshold / low battery voltage / TWLAD2 running / rpm or load over threshold / TWLAD running / long term adjustment completed / short term carburettor adjustment not active	Reasons for de-activation of long term adaptivity
	Engine variant	1/2	1 if standard mapping is enabled, 2 if racing mapping is enabled
	Injectors per cylinder	1cil	Not modifiable : 1cil must display
	Cylinder head sensor	no	Not modifiable : no must display
	Boost adjustment	no	Not modifiable : no must display
	Lambda sensor	yes	Modifiable only with password – normally yes, i.e. lambda sensor present
	Water injection	no	Not modifiable : no must display
	Minimum motor present	yes	Modifiable only with password – normally yes, i.e. minimum motor present
	Purge valve	yes/no	Modifiable only with password : must be yes only for USA version
	Electronic reverse	no	
	Electric starting	yes	Not modifiable : yes must display
	ECU initialised	yes	Indicates that the « ECU initialised » parameter has been enabled If the ECU is replaced, this parameter must be enabled
DEVICE ACTIVATION	Errors reset		
	Fuel pump		
	Intake distribution		
	Lambda sensor heating		
	Fan		
	Purge valve		Activation only for USA version
	Front injector		
	Rear injector		
	Front coil		
	Rear coil		
ADJUSTABLE PARAMETERS	Initialisation		To reset adaptive parameters when changing the ECU / throttle body / injectors (may stay at around 5000 rpm for the first few seconds after ignition) The engine ignition number counter (frozen error parameters) is reset
	Throttle position self-teaching		ECU throttle sensor and stepper motor position self-teaching
	CO adjustment 1		Modifiable only with password in case the CO level cannot be balanced using the throttle bypass screws
	CO adjustment 2		Modifiable only with password in case the CO level cannot be balanced using the throttle bypass screws
	Engine variant		Set to 1 for standard mapping, 2 for racing mapping
	Lambda sensor		Modifiable only with password : for deactivating the lambda sensor independently of the mapping type
	Idling control motor present		Modifiable only with password : for deactivating the idling control motor
	Purge valve		Modifiable only with password : must be yes only for USA version

	ECU initialised			Activation required for new ECU installation (activates a set of parameters)
FROZEN PARAMETERS	Engine load		%	Contrary to the engine parameters display, here expressed as %
	Water temperature		°C	
	Air temperature		°C	
	Battery voltage		V	
	Intake pressure	approx 60	kPa	Parameter of little significance, highly dependent on conditions
	Vehicle speed		kph	
	Engine speed		rpm	
	Throttle position		%	
	Cylinder 1 dwell point		°	
	Engine in VL mode	no		
	Cut off active			
	Status	Not recognised by dashboard		Parameter without significance
	Frequency	1-2	-	Number of times error detected by ECU (including ECU checks at power up, for certain error types)
	Time since ignition	1-0	min	Time since ignition for last detection of error in question
	Driving cycles	7-8	-	Number of times the engine had been switched on at the time of detection of the error in question The counter resets when the Initialisation parameter is enabled
Operating time	72-72	min	Total minutes of operation of the engine at the last time of detection of the error in question The counter does not reset when the Initialisation parameter is enabled	

The following options are available from the adjustable parameters display :

- throttle position sensor alignment,
- ECU initialisation, including throttle alignment, minimum stepper motor reset and lambda sensor adaptive parameters reset.
- ECU initialisation, required when a new ECU is installed

Throttle position alignment must be done whenever the throttle body / ECU is replaced.

- Select function : « Throttle position self-teaching ».
- Make sure the throttle is fully closed
- Press ENTER "  ".
- Turn the key to OFF and wait for at least 30 seconds.

ECU initialisation must be done whenever important engine components (valves, cylinder, camshaft), the exhaust system, ECU, fuel system or lambda sensor are replaced

The three self-adaptive correction factors for lambda sensor control of injection timing are electronically reset .

- Select the function « initialisation »
- Make sure the throttle is fully closed
- Press ENTER "  ".
- Turn the key to OFF and wait for at least 30 seconds.

Initialisation enables activation of a new ECU

- Select function : « ECU initialised ».
- Follow the instructions to enable the new ECU
- Turn the key to OFF and wait for at least 30 seconds.

3.1.5. AIRBOX

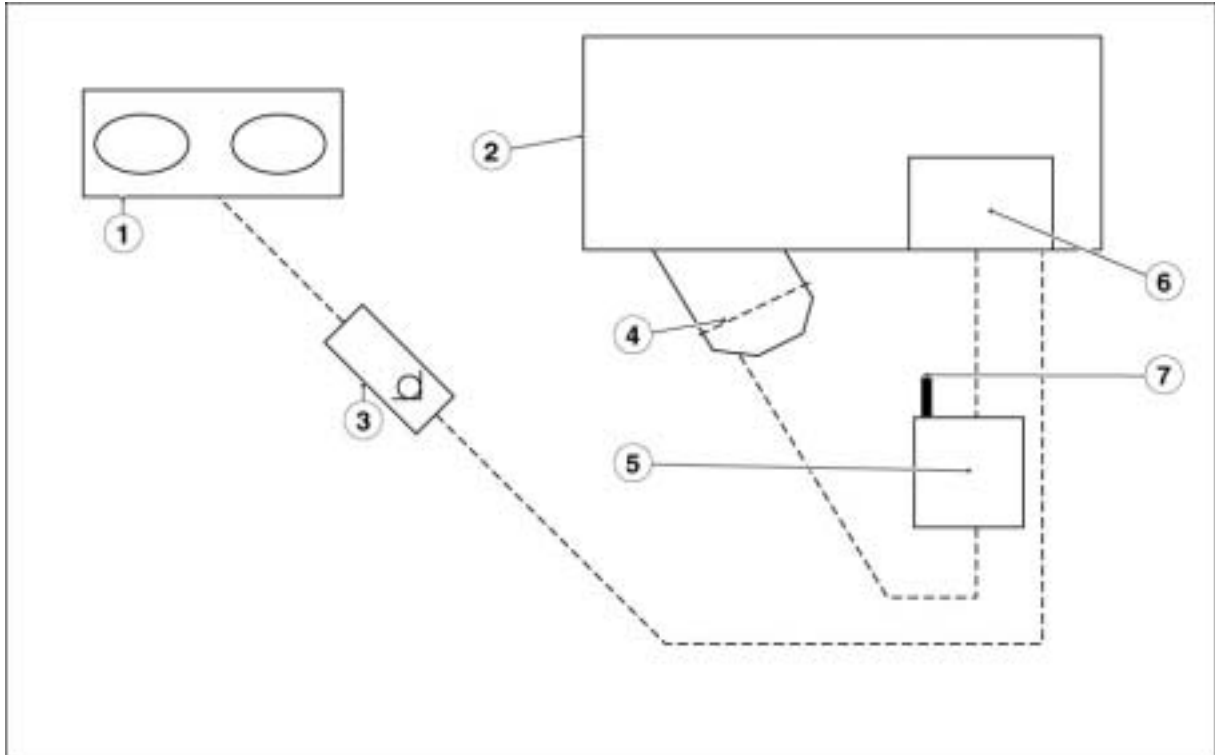
**Key:**

1. Throttle body
2. Front air intake
3. Check valve
4. Membrane
5. Solenoid valve
6. Vacuum chamber
7. Atmospheric pressure

Air intake is controlled by a flap in the duct leading from the windshield to the airbox.

This flap reduces engine noise at low engine speeds.

The flap assembly is composed of : hatch / tie-rod / membrane / solenoid valve

The flap is normally closed and opens in the following circumstances :

minimum 6500 rpm

minimum 30 % throttle opening

The vacuum chamber acts to prevent pressure pulses

If the check valve is to be replaced, take care to fit it in the correct position : The white part must be facing the vacuum chamber.

3.2. FUEL PUMP

3.2.1. REMOVING THE FUEL PUMP ASSEMBLY

- Completely remove the fuel tank.

IMPORTANT Position the tank on a clean surface with the pump unit uppermost.

- Unscrew and remove the eight screws (1).

IMPORTANT To refit, start all screws (1) manually in their holes and tighten in a cross pattern.

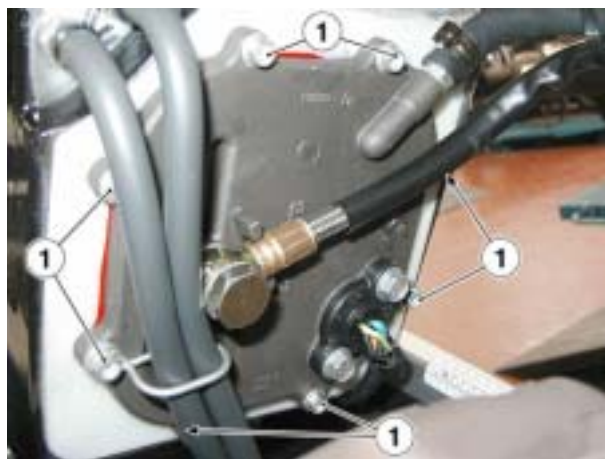

WARNING

When removing the pump assembly make sure not to damage the fuel hoses and level sensor.

- Remove the entire fuel pump assembly.



3.2.2. REMOVING THE FUEL LEVEL SENSOR

- Remove the entire fuel system.
- Disconnect the connector.



- Release and remove the 2 screws.
- Remove the fuel level sensor.



3.2.3. REMOVING THE DELIVERY FILTER

- Remove the whole fuel supply pump unit.

NOTE: Have the appropriate special tool **OPT** to hand:
- **aprilia** part# 0277295 (hose clamp installation pliers).



CAUTION

Upon installation, replace the hose clamp that has been removed with a new one having the same dimensions.

Do not attempt to reinstall the removed hose clamp, since it is unusable.

Do not replace the removed hose clamp with a screw clamp or with other types of clamp.

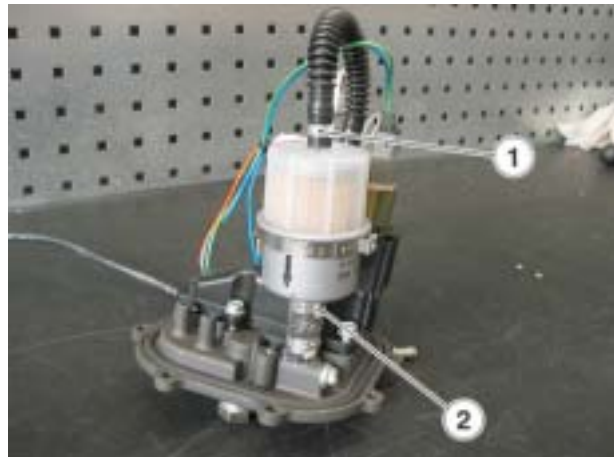

- Release the hose clamp (1).
- Slip the pipe off the filter.
- Release the hose clamp (2).
- Slip the filter off the pipe.



CAUTION

Do not use filters that have already been used.

- Replace the filter with a new one of the same type.

3.2.4. REMOVING THE FUEL SUPPLY PUMP

- Remove the whole fuel supply pump unit.

NOTE Have the appropriate special tool OPT to hand:
- **aprilia** part# 0277295 (hose clamp installation pliers).



CAUTION

Upon installation, replace the hose clamp that has been removed with a new one having the same dimensions.

Do not attempt to reinstall the removed hose clamp, since it is unusable.

Do not replace the removed hose clamp with a screw clamp or with other types of clamp.

- Release the hose clamp (1).
- Pull the fuel pipe off the pump.



- Disconnect the electric connector.



- Disconnect the electric connector.



- Unscrew and remove the 3 screws.



- Bend the fuel filter over sideways and keep it held down.

If the filtering mesh features traces of sediments, clean it using a compressed air jet directed so that the impurities do not get inside.



3.3. THROTTLE BODY

3.3.1. REMOVING THE THROTTLE BODY



WARNING

The throttle setting screws (1) are painted over and cannot be adjusted. Only if the entire cable fitting (2) is to be replaced can the setting screws be adjusted. The two M4x12 (3) screws securing the throttle valve potentiometer are painted over and can only be extracted if the sensor itself is being removed.

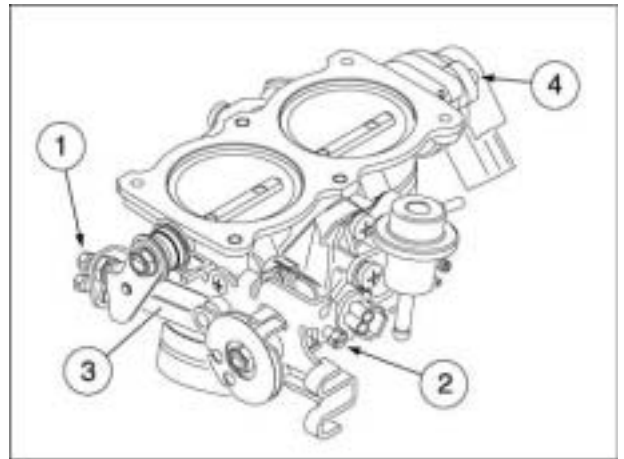

- Partially remove the fuel tank.
- Remove the airbox.
- Detach the electrical connectors.
-
- right injector ;



- left injector ;



- throttle valve potentiometer.



IMPORTANT Make sure to use the special **OPT** tool:
 - *aprilia* part# 0277295 (snap clip pliers).

- Undo the snap clip (4).
- Undo the snap clip (5).
- Extract the hoses from the throttle body.



- Undo the two throttle control cables.



WARNING

During rebody, make sure the two throttle control cable adjusters are correctly mounted to their fittings and check/adjust their play.



- Extract the airbox flap hose from the throttle body.



- Undo the two clips

**WARNING**

When removing the throttle body proceed with care as it is still connected to the fuel tank via the fuel hose.

- Grip the throttle body firmly and move it up and away from the intake flanges with small rocking movements.
- Place the entire throttle body and fuel tank, which are connected to each other, on a clean surface.



When reassembling :

- the fuel delivery hose must not be twisted or constricted by other components ; if it is damaged or degraded in any way, it must be replaced ;
- the fuel delivery hose must be positioned in such a way as to reach the right hand side of the throttle body from below, passing between the two intake flanges ;
- the throttle body must be perfectly seated on the intake flanges ;
- the clips must be fully tightened down.



3.3.2. DISASSEMBLING THE THROTTLE BODY

- Unscrew and remove the M8x1 nut (1) and remove the spring washer.



- Turn the throttle valve control lever (2) slightly, unscrew and remove three T.E. M5x12 screws (3).

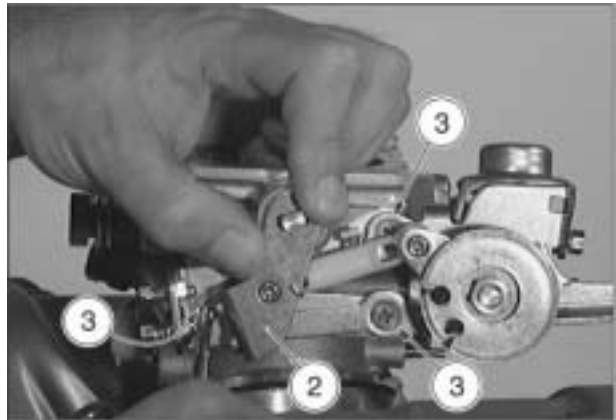

- Slip the whole support bracket (4) securing the throttle cables, with the two bushes (5) and the torsion spring (6), off the throttle body.

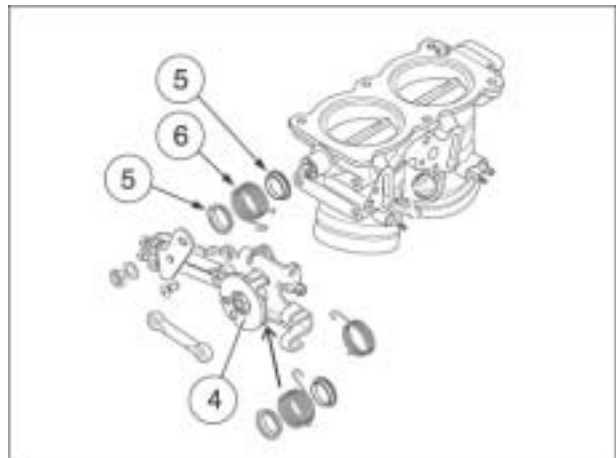

- Unscrew and remove the two M6x16 screws (7) and remove the fuel pressure regulator (8) complete with O-ring.
- Unscrew and remove the three M6x25 screws (9) and remove the left injector support (10) - together with the relevant gasket (11), injector (12) and sealing ring (13) - from the throttle body.

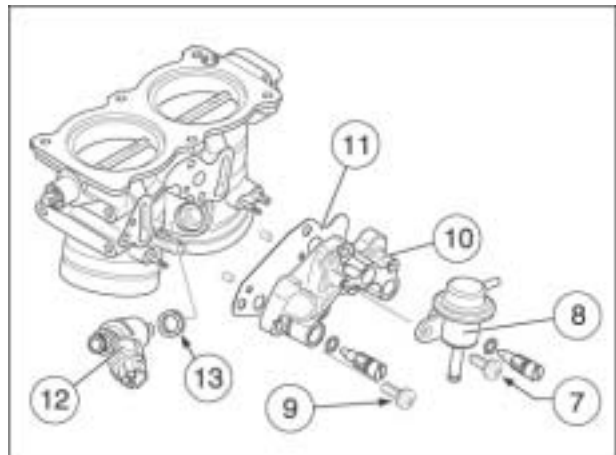

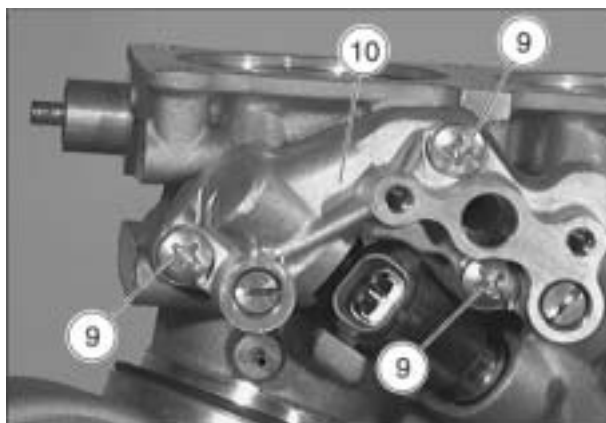

- Unscrew and remove the two M6x25 screws (14) and the right injector support (15), together with the relevant gasket (16), injector (17) and sealing ring (18).

NOTE The injector's sealing ring (18) may be kept inserted in the slot on the throttle body.

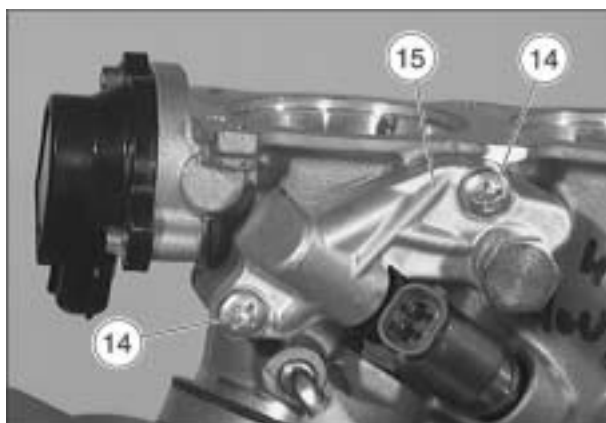
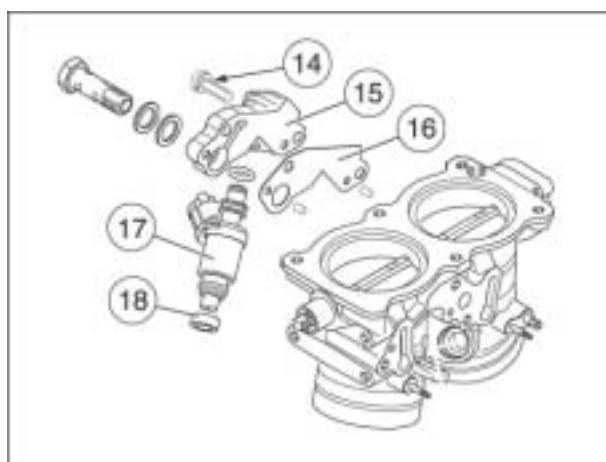

- Unscrew and remove the M8x1 nut (19) and remove the spring washer (20), the pulley (21), the two bushes (22) and torsion spring (23).

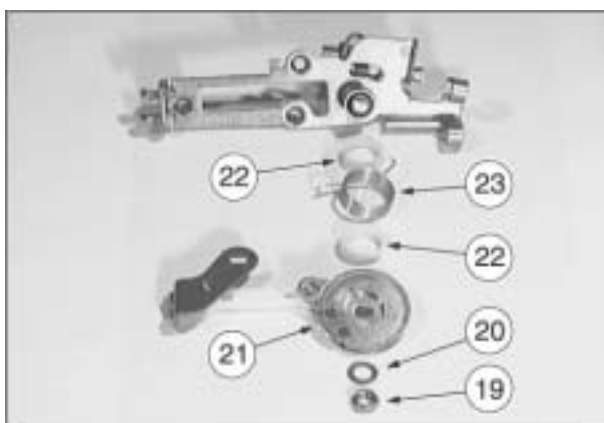
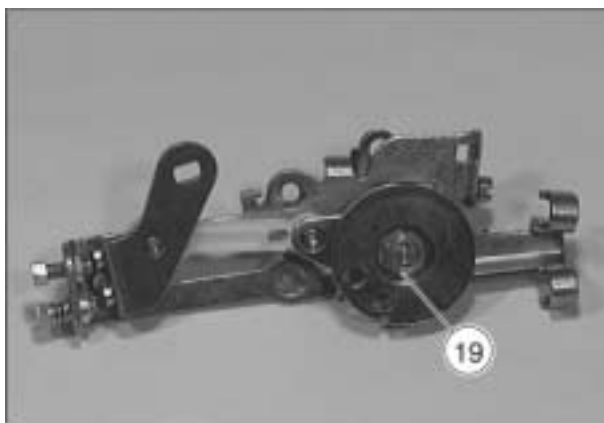

- Slide the fulcrum pin (24), together with the lock washer (25), out of the hole on the throttle cable support bracket and remove the two shaft sealing rings (26) with the torsion spring (27) and cold-start lever (28).

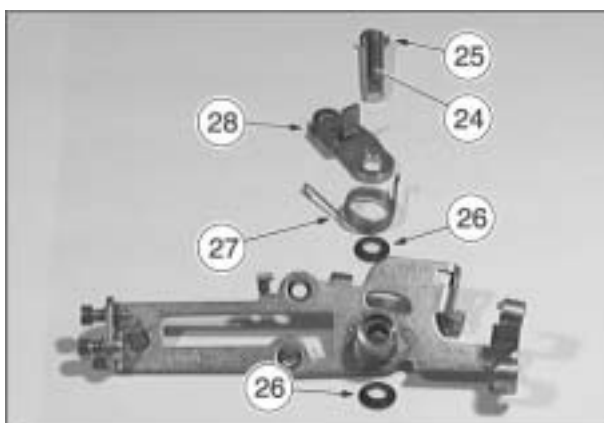
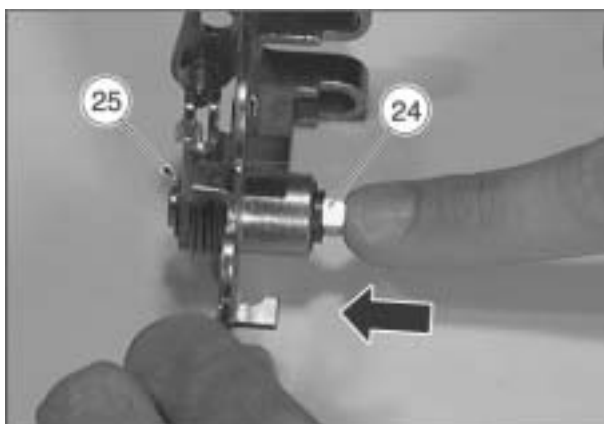

3.3.3. INSPECTING THE THROTTLE BODY TESTING THE INJECTOR

NOTE The injectors can be controlled electrically.

- Check the following components:
 - wiring and connections;
 - injector or injection signal of the engine control unit.

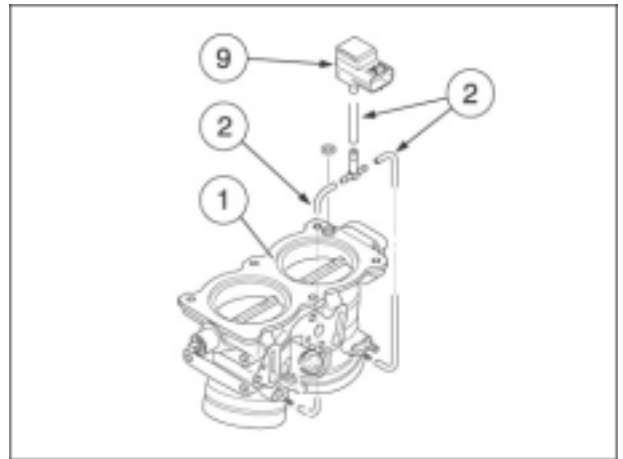

THROTTLE BODY

- Clean all the openings and pipes of the throttle body (1) using compressed air.
- Check the pipes of the intake pressure sensor (2), watching out for any clogging.
- Check the throttle valves unit and the cable fastening mechanism (3), watching out for any signs of mechanical damage.

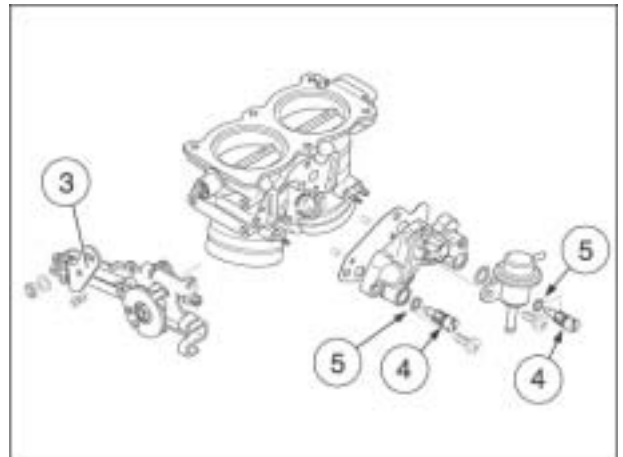

NOTE In the event the synchronization screws (4) or O-rings (5) are replaced, synchronize the cylinders.

- Unscrew the two cylinder synchronization screws (4) only in case of air escapes.
- When replacing the tie rod of the ball joint (6), disengage the tie rod from the throttle valve control lever (7) and throttle cable pulley (8).
- Once a new ball joint tie rod (6) has been fitted, make sure it moves freely.

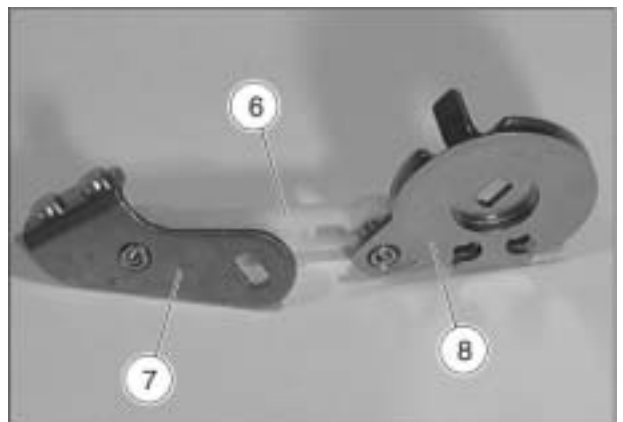

3.3.4. REFITTING THE THROTTLE BODY



CAUTION

After disassembling the throttle body, replace all the gaskets, O-rings, torsion springs, bushes and seals. These components are supplied with the repair kit..

- Fit the new O-rings (1) and seals (2) on both injector.
- Insert the injector (3) in the left injector support (4) and in the right injector support (5).
- Fit the left injector support gasket (6), right injector support gasket (7) and the two seals (8) on the throttle body.
- Install the complete left injector support (4) and right injector support (5) in the throttle body, fastening them with the new M6x25 (9) (10) screws respectively.
- If the synchronizing screws (11) and respective O-rings (12) have been replaced, screw on the screws (11) fairly tight until they touch the stop and then unscrew them a single turn.

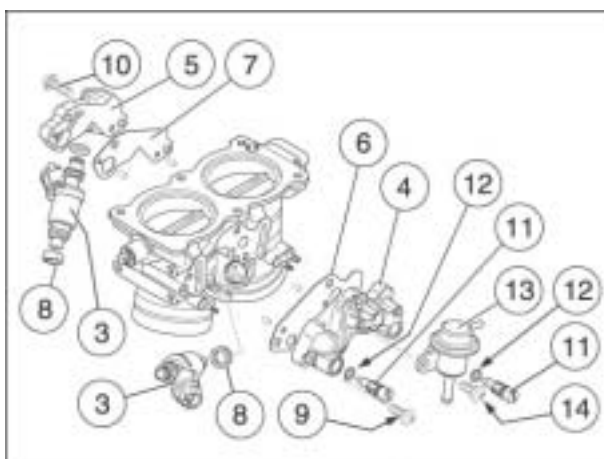
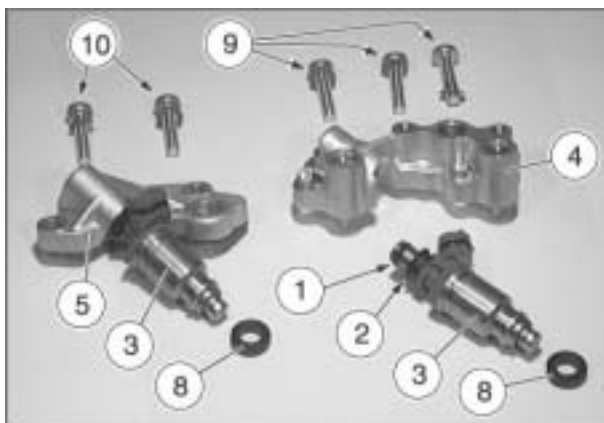

Presetting of synchronizing screws (11): 1 turn.



CAUTION

The precise adjustment of the screws (11) must be performed using a vacuum gauge.

- Fasten the fuel pressure regulator (13) using the two M6x16 screws (14).

NOTE Smear a film of grease over the surfaces of the fulcrum pin (18).

- Insert the cold-start lever (15), torsion spring (16) and shaft sealing ring (17) on the fulcrum pin (18).
- Insert the complete fulcrum pin (18) in the throttle cable support bracket.



NOTE Make sure the torsion spring is hooked to the cold-start lever (15) and cable support bracket.

- Spray chain grease onto the spring (16).
- Insert the shaft sealing ring (17) on the fulcrum pin (18).
- Fit the two bushes (19) and torsion spring (20).
- Fit the pulley (21) on the throttle cable support bracket.



**CAUTION**

Make sure that the ends of the torsion spring (20) are hooked onto the throttle cable support bracket and pulley (21).

NOTE Spray a temporary lubricant on the spring (20), see 1.9.2 (USE OF CONSUMABLES).

- Fit the spring washer (22).

NOTE Apply LOCTITE® 243 on the thread of the nut (23).

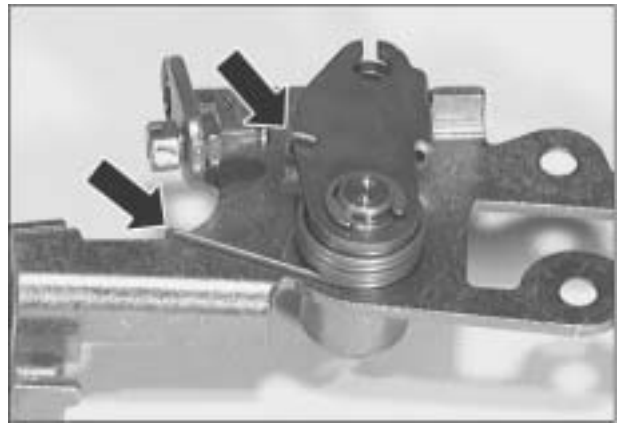

- Screw the M8x1 nut (23) and tighten it.

NOTE Apply LOCTITE® 243 on the thread of the screws (25).

- Fasten the anchoring bracket of the accelerator cables (24) with the three hex-head screws M5x12 (25).
- Fit the throttle valve control lever (26).

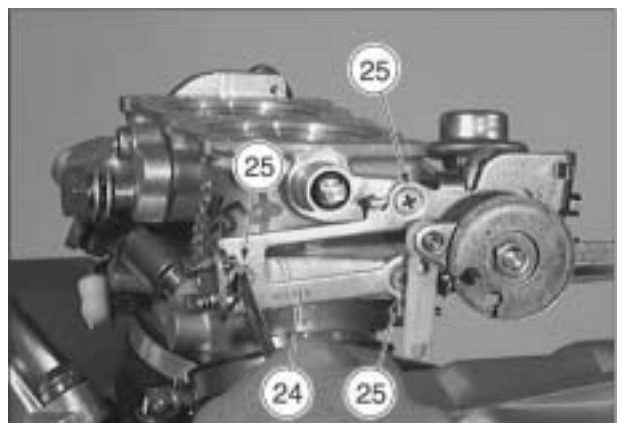
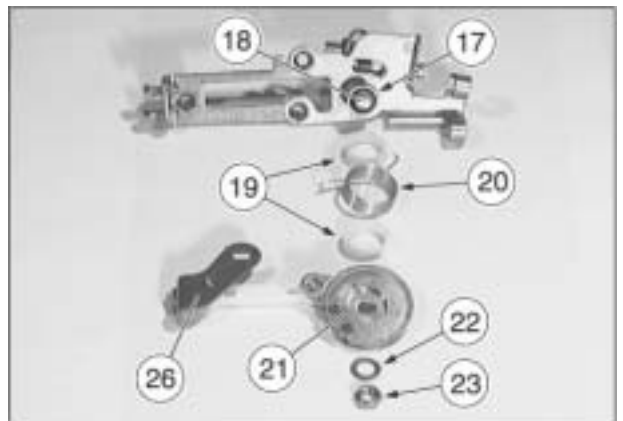

3.3.5. REPLACING THE THROTTLE VALVE CONTROL LEVER

DISASSEMBLY

- Partially remove the fuel tank.
- Remove the air filter casing.
- Unscrew and remove the M8x1 nut (1) and remove the spring washer.
- Slide out the control lever (2) and retrieve the two bushes (3) and torsion spring (4).
- Remove the control lever (2) from the tie rod of the ball joint (5).

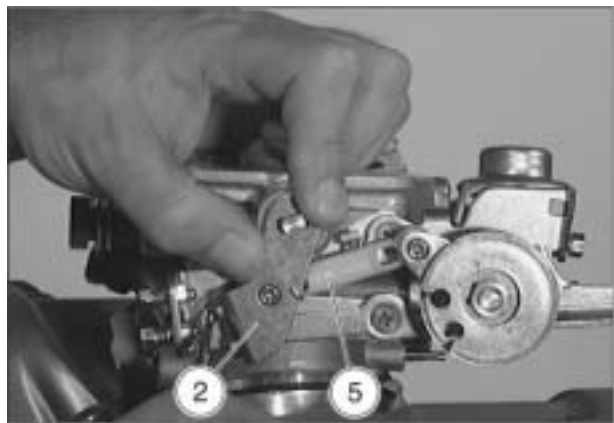

ASSEMBLY

- Fit the two bushes (3) and torsion spring (4) on the throttle body.
- Fit the throttle valve control lever (2) on the throttle valve spindle.

NOTE Spray a temporary lubricant on the spring (4).



CAUTION Make sure the ends of the torsion spring (4) are hooked onto the throttle body and throttle valve control lever (2).

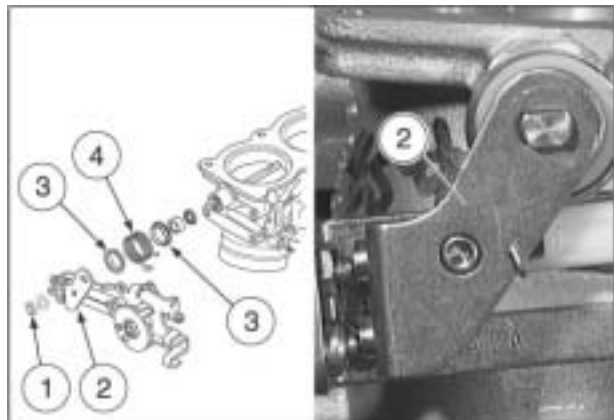

- Fit the spring washer.

NOTE Apply LOCTITE® 243 on the thread of the nut (1).

- Screw the M8x1 nut (1) and tighten it.

NOTE Once assembly is complete, make sure the levers rotate freely.

The throttle valve control lever (2) must be returned to its original position by the torsion spring. Check for end play on the throttle valve control shaft and adjust as necessary.



3.3.6. CHECKING THROTTLE VALVE CONTROL SHAFT END PLAY

- Partially remove the fuel tank.
- Remove the air filter casing.

NOTE Have an appropriate thickness gauge (1) to hand with a 0.05 mm scale.

With throttle valves closed:

- Use the thickness gauge (1) to measure the minimum play between the lever (2) and the contact surface (3) on the throttle body in a number of points.

End play: min. 0.1 mm.



CAUTION

If the minimum value measured is lower than 0.1 mm, the throttle body must be replaced.

With throttle valves open:

- Repeat the above procedure.

End play: min. 0.15 mm.



CAUTION

If the minimum value measured is lower than 0.15 mm, the throttle body must be replaced.

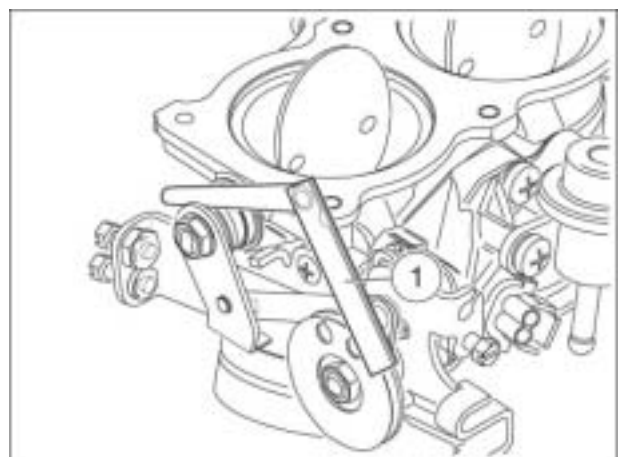
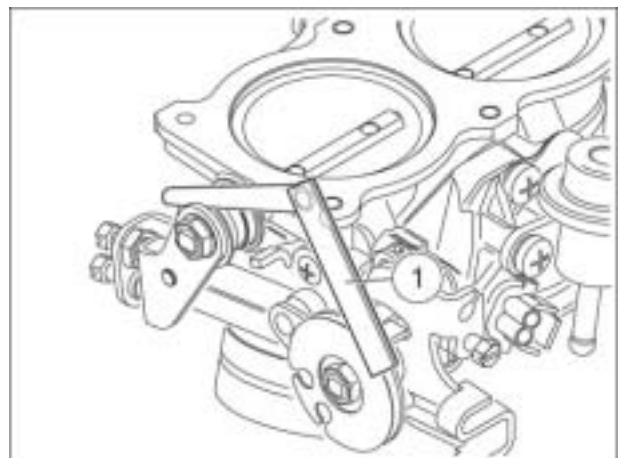
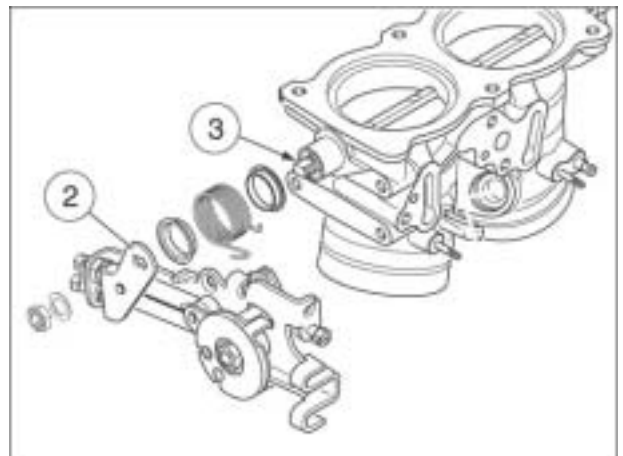
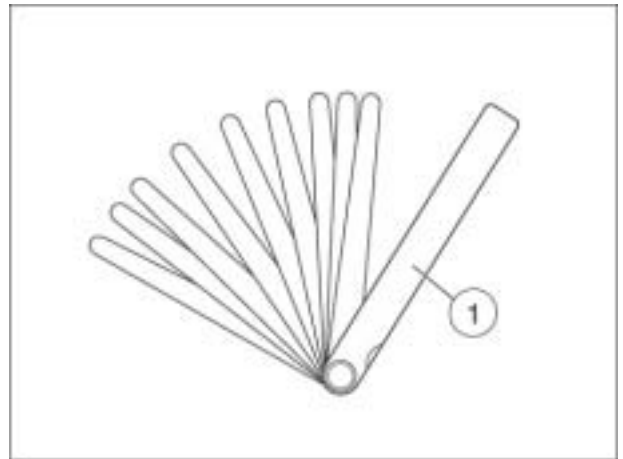

ENGINE

4

SUMMARY

4.1.	ENGINE.....	3
4.1.1.	REMOVING THE ENGINE.....	3
4.1.2.	REINSTALLING THE ENGINE	26
4.1.3.	TIGHTENING TORQUES	51

4.1. ENGINE

4.1.1. REMOVING THE ENGINE

- Remove the airbox cover.
- Unscrew the screw securing the airbox to the frame.
- Remove the six screws securing the throttle body to the airbox





- Detach the by pass lines to the throttle body and the stepper motor connector



- Remove the oil vapour recovery line



- Detach the manifold pressure sensor connection and the lines coming from the throttle body





- Remove the airbox



- Disconnect the cabling from the ignition coil



- Disengage the throttle cables



- Detach the throttle potentiometer connector



- Remove the vacuum lines from the throttle body





- Disconnect the injector connectors



- Slacken off the clamps on the intake manifolds



- Remove the throttle body

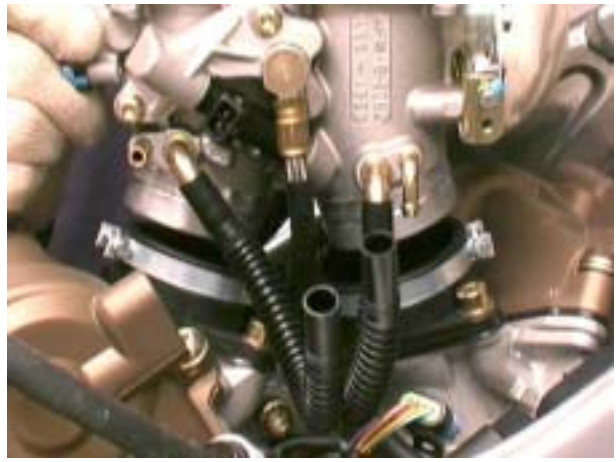

- Close the lines so that impurities are unable to enter the cylinders



- Open the clamps on the lubrication circuit lines leading to the oil tank





- Detach the engine casing oil lines



- Undo the three screws securing the oil tank



- Remove the oil tank and extract the line coming from the radiator.



- Remove the fairing air dam by undoing its screws (2 central 4 side).



- Extract the bleed lines from their seat



- Remove the oil line on the engine casing.



- Undo the stud mounting the oil line clamp to the engine casing



- Disconnect the oil hose from the right side.



- Release and remove the four screws securing the oil radiator subframe.



IMPORTANT To remove the left side screw, hold the inner nut steady with a wrench.



- Remove the subframe complete with oil radiator.



- Remove the rear brake fluid tank



- Undo the screws securing the rear brake pump



- Undo the clip securing the pump to the brake lever



- Detach the line leading to the expansion tank



- Undo the screws securing the expansion tank and remove it



- Detach the engine oil pressure sensor connector



- Detach the lambda sensor, stop light switch, speed sensor and rectifier connections.



- Remove the lower radiator mounts and move it away while maintaining it in a vertical position.



- Unscrew the starter motor connector



- Release the silencer mounting clips



- Undo the screw retaining the silencer clamp



- Remove the silencers



- Release the clip securing the front cylinder manifold to the exhaust



- Undo the four nuts securing the manifold to the front cylinder



- Remove the manifold



- Retain the gasket



- Undo the clip securing the rear manifold to the exhaust



- Extract the lambda sensor cable from the frame



- Remove the entire exhaust assembly including the lambda sensor



- Undo the four nuts fixing the manifold to the rear cylinder
- Remove the exhaust manifold and retain the gasket
- Disconnect the temperature sensor, timing sensor, engine speed sensor, side stand safety switch and generator connectors.





- Detach the spark plug cap





- Remove the gearshift lever



- Remove the clutch lever and flange



- Remove the pinion casing and guide plate on the engine casing



- Undo the bolt securing the pinion and retain the washers



- Remove the pinion



- Open the clamps and remove the coolant lines on the radiator



- Undo the engine casing ground connectors



- Detach the neutral sensor connector



- Remove the rear brake lever



- Remove the lever mount and rear brake pump
- Remove the brake pump mount



- Detach the vacuum line on the pneumatic clutch actuator



- Support the engine with a suitable support



- Undo the screws mounting the engine to the frame at the rear

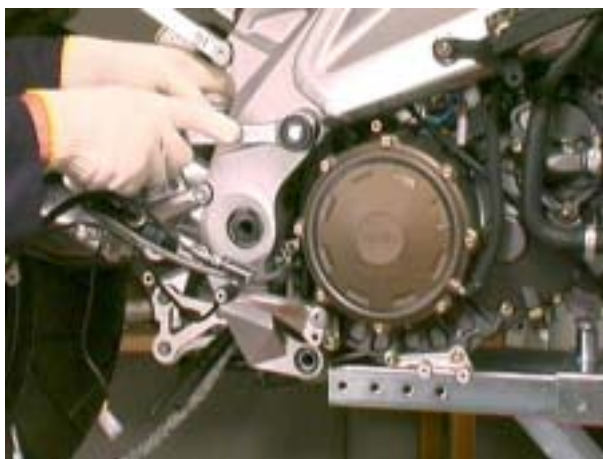
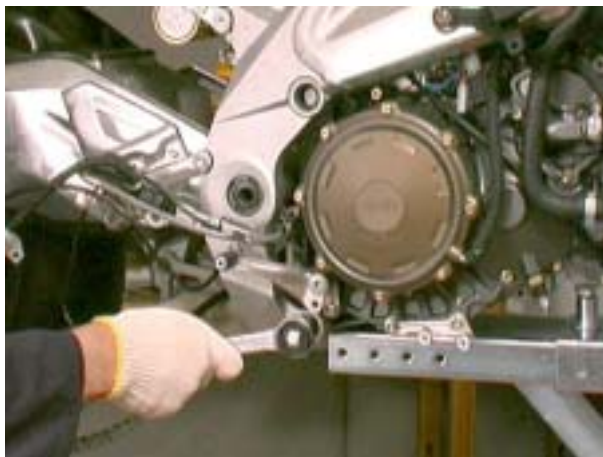

- Undo the four screws on the front engine mounts



- Remove the screws and the spacers between the frame and the engine.



- Slacken off the adjuster bushings between the engine and the frame



- Fully lower the engine



4.1.2. REINSTALLING THE ENGINE

- Place the engine on a suitable support



- Partly raise the engine.



- Position the engine so that the rear mounts are aligned with the frame



- Locate the front left spacer.



- Fit the two screws to the front left mount.



- Locate the rear left spacer and tighten the screw to the prescribed torque.



- Fit the rear left screw.



- Locate the front right spacer



- Fit the two screws to the front right mount.
- Tighten down the four left side screws.



- Tighten the upper right bush to the prescribed torque.



- Tighten the upper right nut to the prescribed torque.



- Tighten the lower right bush to the prescribed torque.



- Tighten the lower right nut to the prescribed torque.



- Fit the upper right screw.



- Fit the lower right screw.
- Tighten down the four right side screws.



- Remove the engine support



- Refit the pneumatic clutch actuator vacuum line and secure it with a clamp



- Fit the rear brake lever mount and pump and tighten the screws to the specified torque



- Fit the rear brake lever and tighten the screws to the specified torque



- Fit the rear brake pump and connect it to the brake lever



- Screw in the neutral sensor connector



- Refit the engine casing ground connectors and tighten their screws to the specified torque



- Fit the coolant lines to the radiator and secure them with clamps



- Fit the pinion in the right orientation



- Mount the pinion, tightening to the specified torque



- Fit the pinion casing and guide plate and tighten the screws to the specified torque



- Fit the clutch lever complete with flange



- Mount the gear shift lever



- Fit the spark plug caps



- Hook up the temperature sensor, timing sensor, engine speed sensor, side stand safety switch and generator connectors.





- Mount the rear cylinder exhaust manifold with its gasket



- Tighten the studbolt nuts to their specified torque



- Fit the entire exhaust assembly complete with lambda sensor



- Insert the clip securing the rear manifold and exhaust
- Secure the lambda sensor cabling to the frame



- Fit the exhaust gasket to the front cylinder



- Fit the manifold to the cylinder studbolts and exhaust



- Tighten the four nuts securing the manifold to the cylinder to the specified torque



- Reconnect the clip securing the front cylinder manifold to the exhaust



- Refit the silencers



- Screw on the silencer clamp screws



- Clip on the silencer clips



- Screw in the starter motor connector



- Move the radiator towards the engine and refit the lower mounts



- Hook up the lambda sensor, stop light switch, speed sensor and rectifier connections.





- Connect up the engine oil pressure sensor connector



- Fit the expansion tank and screw in the two mounting screws



- Connect the line leading to the expansion tank



- Engage the brake lever pump clip



- Tighten the screws securing the rear brake pump



- Fit the rear brake fluid tank



- Fit the subframe complete with oil radiator.
- Tighten down the four screws to the prescribed torque.





- Connect the oil hose from the right side.



- Screw in the stud mounting the oil line clamp to the engine casing



- Fit the oil line to the engine casing



- Insert the bleed lines in their seats.

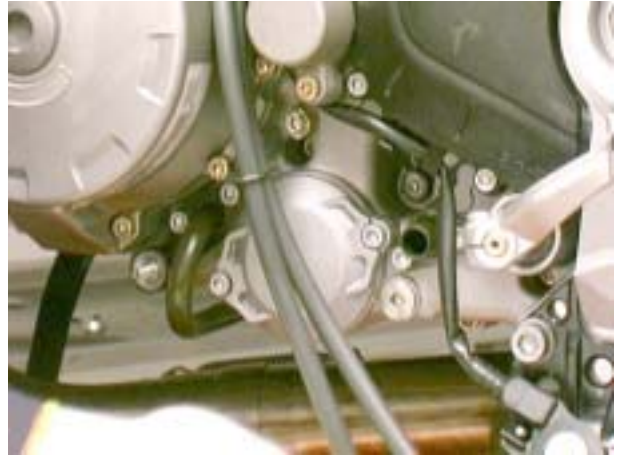

- Screw in the two screws securing the conveyor to the coolant radiator mount
- Fit the coolant radiator conveyor



- Fit the fairing air dam and tighten its screws (2 central 4 side).





- Fit the oil tank and the oil radiator line



- Tighten down the three screws securing the oil tank



- Mount the oil lines to the engine casing



- Tighten the clamps on the lubrication circuit lines leading to the oil tank



- Remove the protectors inserted into the lines



- Fit the throttle body



- Tighten down the clamps on the intake manifolds



- Hook the connectors to the injectors



- Fit the vacuum lines to the throttle body



- Refit the throttle potentiometer connector



- Fit the throttle control cables and adjust their play



- Connect the cabling to the ignition coil



- Fit the airbox



- Tighten the six screws securing the airbox to the throttle body to the specified torque

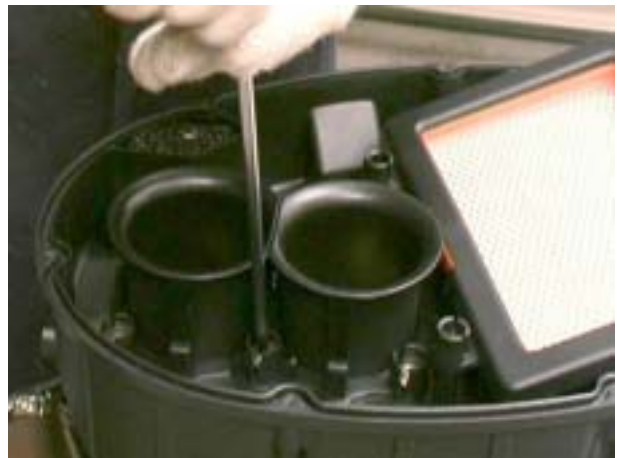

- Tighten the screw mounting the airbox to the frame at the front to the specified torque



- Hook up the throttle body hoses to the stepper motor.



- Refit the manifold pressure sensor connector



- Hook up the oil vapour recovery line and secure it with its clamp



- Connect the stepper motor and bypass lines leading to the throttle body



- Fit the airbox cover



4.1.3. TIGHTENING TORQUES

DESIGNATION	QUANTITY	SCREW / NUT	TORQUE (Nm)	NOTES
ENGINE				
Engine mounting to frame				
Front fitting	2+2	M10	50	-
Left side upper and lower rear fitting	2	M10	50	-
Adjuster bushing upper and lower rear fitting	2	M20x1,5	12	-
Locknut right side upper and lower rear fitting	2	M20x1,5	50	-
Screw right side upper and lower rear fitting	2	M10	50	-
Components mounted to engine				
Engine oil intake flange	2	M6	10	-
Engine oil outlet flange	2	M6	10	-
Rear brake lever mount	1	M6	10	-
Rear brake lever mount	1	M8	25	-
Rear brake pump mount	2	M8	25	-
Pinion mount	1	M10	50	Loctite 243
Clutch control cylinder mount	3	M6	10	-
Pinion cover mount	3	M6	10	-
Throttle body fuel delivery hose mount	1	M12x1,5	22	-
72/78 kW reduction bushing mount	1	M5	3±10%	Loctite 243

CYCLE PARTS

SUMMARY

5.1.	BODY PANELS	4
5.1.1.	REMOVING THE BODY PANELS	4
5.1.2.	BODY PANEL REASSEMBLY	13
5.1.3.	TIGHTENING TORQUES	21
5.2.	FRONT FORK	22
5.2.1.	DIAGRAM (RSV R).....	22
5.2.2.	REMOVING THE FORK LEGS.....	24
5.2.3.	FITTING THE FORK LEGS	28
5.2.4.	CHANGING THE FORK FLUID (RSV R).....	31
5.2.5.	TOPPING UP THE FORK FLUID (RSV R).....	34
5.2.6.	REPLACING THE OIL/DUST SEAL (RSV R).....	37
5.2.7.	REFITTING THE OIL/DUST SEAL (RSV R).....	44
5.2.8.	CHECKING THE COMPONENTS	51
5.2.9.	FRONT FORK DIAGRAM	55
5.2.10.	CHANGING THE FORK FLUID (RSV FACT)	56
5.2.11.	TOPPING UP THE FORK FLUID (RSV FACT).....	58
5.2.12.	REPLACING THE OIL/DUST SEAL (RSV FACT).....	60
5.2.13.	TIGHTENING TORQUES	63
5.3.	STEERING BEARING	64
5.3.1.	DIAGRAM	64
5.3.2.	CHECKING THE BEARING SLACK STEERING.....	66
5.3.3.	STEERING BEARING ADJUSTMENT	67
5.3.4.	TIGHTENING TORQUES	71
5.4.	REAR SUSPENSION	72
5.4.1.	DIAGRAM	72
5.4.2.	REMOVING THE REAR SUSPENSION.....	73
5.4.3.	CHECKING THE COMPONENTS	77
5.4.4.	REFITTING THE REAR SUSPENSION.....	79
5.4.5.	DISASSEMBLING THE REAR SUSPENSION LINKAGE.....	82
5.4.6.	TIGHTENING TORQUES	83
5.5.	SWINGING ARM	84
5.5.1.	REMOVING THE SWINGING ARM.....	84
5.5.2.	CHECKING THE COMPONENTS	87
5.5.3.	DISASSEMBLING THE REAR FORK GASKETS.....	88
5.5.4.	REFITTING THE SWINGING ARM	89
5.5.5.	TIGHTENING TORQUES	92
5.6.	FRONT WHEEL.....	93
5.6.1.	DIAGRAM	93
5.6.2.	REMOVING THE WHEEL.....	94
5.6.3.	CHECKING THE FRONT WHEEL COMPONENTS.....	97
5.6.4.	DISASSEMBLING THE FRONT WHEEL BEARINGS.....	99
5.6.5.	ASSEMBLING THE FRONT WHEEL BEARINGS.....	100
5.6.6.	REFITTING THE REAR WHEEL	102
5.7.	REAR WHEEL	104
5.7.1.	DIAGRAM	104
5.7.2.	REMOVING THE REAR WHEEL.....	105
5.7.3.	REMOVING THE FINAL DRIVE UNIT	107
5.7.4.	CHECKING THE REAR WHEEL COMPONENTS.....	109
5.7.5.	DISASSEMBLING THE REAR WHEEL BEARINGS.....	113
5.7.6.	ASSEMBLING THE REAR WHEEL BEARINGS	114
5.7.7.	DISASSEMBLING THE FINAL DRIVE UNIT BEARINGS.....	116
5.7.8.	ASSEMBLING THE FINAL DRIVE UNIT BEARINGS.....	117
5.7.9.	REMOVING THE FLEXIBLE COUPLINGS.....	118
5.7.10.	REMOVING THE CROWN GEAR	119
5.7.11.	REFITTING THE REAR WHEEL	120
5.7.12.	TIGHTENING TORQUES	122
5.8.	FRONT BRAKE	123
5.8.1.	CHANGING THE FRONT BRAKE PADS (RSV R).....	123
5.8.2.	CHANGING THE FRONT BRAKE PADS (RSV FACT).....	124
5.8.3.	CHECKING THE FRONT BRAKE DISCS.....	126
5.8.4.	REMOVING THE FRONT BRAKE DISCS.....	127
5.8.5.	BLEEDING THE BRAKE CIRCUIT	128
5.9.	REAR BRAKE.....	129
5.9.1.	CHANGING THE REAR BRAKE PADS.....	129
5.9.2.	CHECKING THE REAR BRAKE DISC	130
5.9.3.	REMOVING THE REAR BRAKE DISC.....	131

5.10.	CLUTCH.....	132
5.10.1.	BLEEDING THE CLUTCH CIRCUIT.....	132
5.11.	DRIVE CHAIN.....	133
5.11.1.	DRIVE CHAIN.....	133
5.11.2.	INSPECTING THE DRIVING CHAIN SHOE.....	135
5.11.3.	REMOVING THE CHAIN SHOE.....	136
5.11.4.	LOWER CHAIN SHOE.....	138

5.1. BODY PANELS

5.1.1. REMOVING THE BODY PANELS

- Remove the screws securing the fairing from the sides.



- Unclip the clips securing the fairing to the front fairing with the aid of screwdriver



- Remove the clips from their seats with a pair of pliers



- Slide out the fairing sideways, taking care not to damage it



- Remove the upper front fairing panels by undoing the front fairing retaining screws



- Detach the direction indicator connectors and detach the cabling from its mount



- Remove the rear view mirrors



- Undo the clips securing the front fairing to its mount with the aid of a screwdriver



- Remove the clips using a pair of pliers.



- Partially extract the front fairing.



- Detach the six lamp connectors



- Remove the front fairing



- Undo the two screws securing the rider seat and lift it off



- Unlock the passenger seat using the ignition key



- Push the seat forwards so as to disengage it from its mount



- Extract the passenger seat from the belt and remove it



- Undo the screw securing the belt and retain the centring bushings



- Remove the spacers between the tail section and the seat subframe



- Disconnect the passenger seat unlock cable



- Undo the screws securing the side panels



- Extract the side panels



- Undo the screws securing the tail light to the tail section



- Unscrew the six screws securing the tail section to the lower panel



- Separate the tail section from the tail light



- Detach the direction indicator connectors



- Remove the tail section



- Undo the two screws securing the fuel tank



- Remove the screws and turn the tank over



- Detach the bleed tubes



- Detach the fuel delivery and return lines



- Lower the tank



- Disconnect the fuel pump connector



- Remove the rear tank retaining screw



- Remove the tank and slide the cabling out of the frame



5.1.2. BODY PANEL REASSEMBLY

- Locate the tank and its cabling on the frame.



- Fit the rear tank retaining screw.



- Connect the fuel pump connector.



- Raise the fuel tank



- Fit the fuel delivery and return lines



- Connect the bleed lines and secure them with their clamps



- Lower the tank and fit the two front retaining screws



- Fit the tail section



- Connect the direction indicator connectors



- Tighten the six screws securing the tail section to the lower panel



- Install the screws securing the tail light to the tail section
- Install the screws securing the tail section to the seat subframe



- Fit the side panels



- Secure the side panels to the tank and the seat sub-frame



- Connect the passenger seat unlock cable



- Fit the spacers between the tail section and seat sub-frame



- Fit the passenger belt and tighten the two retaining screws



- Mount the passenger seat



- Position the rider seat and secure it with its screws





- Hook up the six lamp connectors



- Fit the front fairing



- Secure the clips



- Fit the rear view mirrors



- Hook up the direction indicator connectors



- Mount the front fairing upper panels and tighten the screws securing the front fairing



- Insert the fairing from the side taking care not to damage it



- Secure the clips securing the fairing to the front fairing with the aid of a screwdriver



- Fit the screws securing the fairing from the side



5.1.3. TIGHTENING TORQUES

DESIGNATION	QUANTITY	SCREW / NUT	TORQUE (Nm)	NOTES
FRAME / FAIRING PANELS				
Front fairing / air scoop	1	M6	3	-
Windshield / front fairing	8	M4	1	-
Fairing / rider footplate and spacer	2+2	M6	4	-
Side fairing panel internal fitting / air dam	4	M5	3	-
Air dam / radiator mounts	2	M5	3	-
Front fairing panel / bottom yoke	3	M6	7	-
License plate holder / lower seat subframe cover	4	M6	3	-
Lower panel / seat subframe	3	M6	5	-
Front lower seat subframe panel / frame	2	M5	4	-
Side body panels / tank	1+1	M5	5	-
Side body panels / seat subframe	2+2	M5	3	-
Rear mudguard	4	M5	3	-
Front mudguard	4	M5	4	-
Rectangular reflector / license plate holder	2	M4	1	-
Stand bushing – lower panel / seat subframe	2	M6	12	-
Left/right side fairing	4	M5	3	-
Rear fairing /passenger seat subframe belt	2	M6	12	-

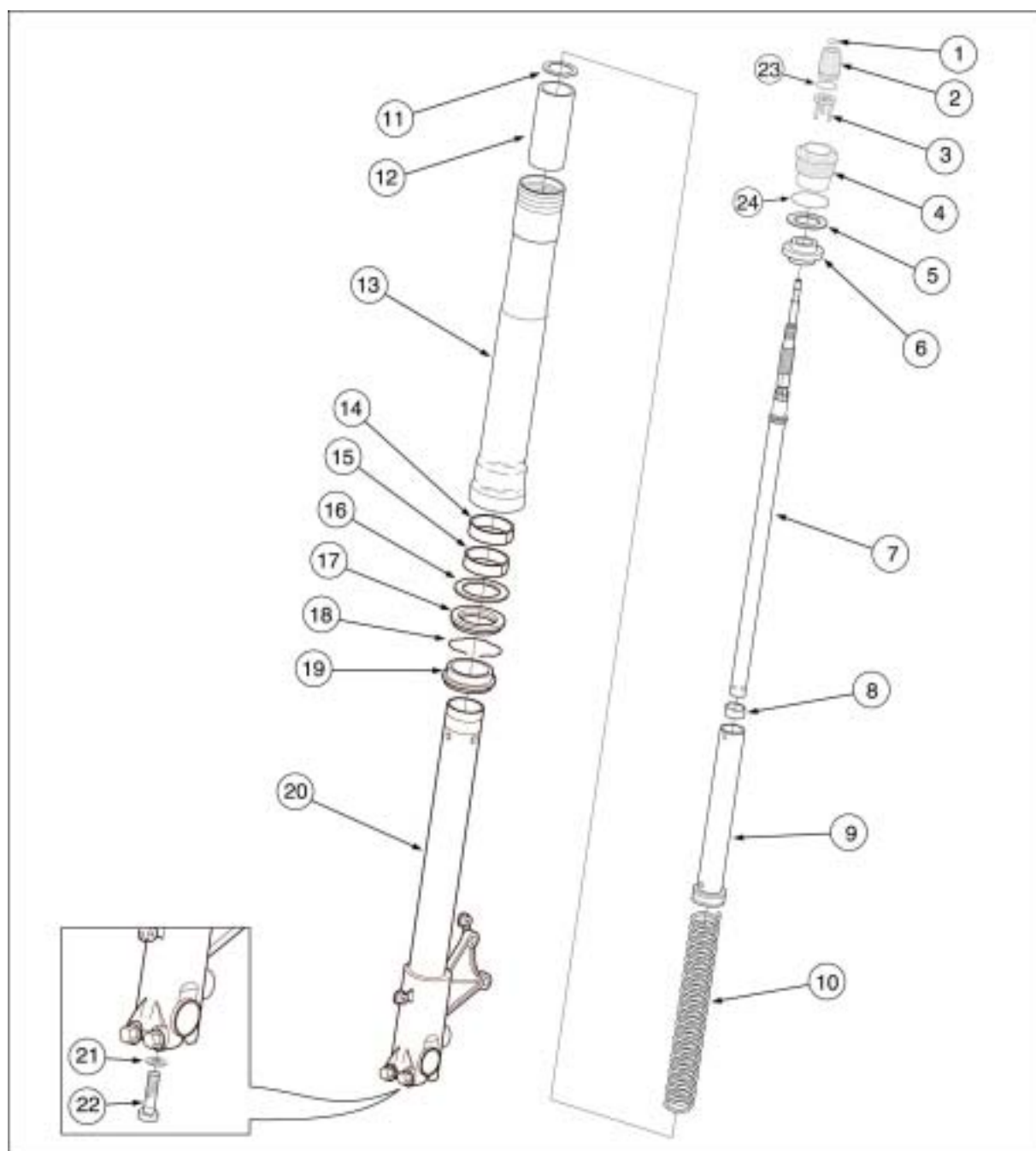
5.2. FRONT FORK**5.2.1. DIAGRAM (RSV R)**

Key:

1. Retainer ring
2. Spring preload adjuster
3. Spring preload pusher
4. Slider upper plug
5. Washer
6. Slide bush
7. Piston assembly
8. Centring bush
9. Spring-press tube
10. Spring
11. Spring rest washer
12. Lower collar
13. Slider
14. Slide bush
15. Guide bush
16. Stop ring
17. Gasket
18. Retainer ring
19. Antidust gasket
20. Wheel-holder tube
21. Copper washer
22. Centre screw
23. O-ring
24. O-ring

5.2.2. REMOVING THE FORK LEGS

- Support the front part of the motorcycle.
- Undo the screws securing the front mudguard and remove it
- Undo the screws securing the front brake calipers and remove them from their seats
- Undo the nut retaining the wheel axle



- Retain the seal washer



- Slacken off the screws on the wheel axle clamps



- Lightly knock the wheel axle with a rubber mallet so as to uncover the holes on the opposite side



- Pull out the hollow axle using a screwdriver in the holes



- While removing the axle support the wheel, and then remove it



- Slacken off the screws securing the handlebar on the side in question to the fork



- Support the fork leg and slacken off the screws on the upper and lower plates



- Extract the fork leg.



5.2.3. FITTING THE FORK LEGS

- Insert the fork leg.
- Adjust the slider resistance and tighten the screws on the fork plates to the specified torque
- Tighten the handlebar screws to the specified torque
- Fit the front wheel



- Fit the wheel axle



- Tighten down the clamp screws (nut side) to secure the wheel axle



- Fit the seal washer and screw on the axle nut to the specified torque
- Make sure the fork legs are aligned by pumping the fork up and down



- Tighten the screws securing the wheel axle clamps to the specified torque



- Tighten the screws securing it to the specified torque

**WARNING**

After fitting the brake callipers repeatedly operate the front brake lever



- Fit the front mudguard



- Install the brake callipers and tighten the screws securing them to the specified torque



5.2.4. CHANGING THE FORK FLUID (RSV R)

- Clamp the slider with the specified tool.



- Set the spring preload to its minimum



- Undo the upper slider cap



- Clamp the fork end taking care not to damage it



- Fit the special tool to the spring coupling



- Push the tool downwards to compress the spring and install the tool spacer under the cartridge locknut



- Slacken off the cap using the locknut for leverage with a wrench fitted to the wrench seat



- Remove the entire cap assembly



- Remove the spacer and the washer
- Press downwards to compress the spring and extract the spacer



- Extract the spring coupling



- Drain the oil into a container and remove the spring



5.2.5. TOPPING UP THE FORK FLUID (RSV R)

- Fill the fork so that any air inside it is vented
- Fit the spring coupling
- Fit the special tool to the spring coupling so as to lock the cartridge stem in position
- Fit the spacer and washer

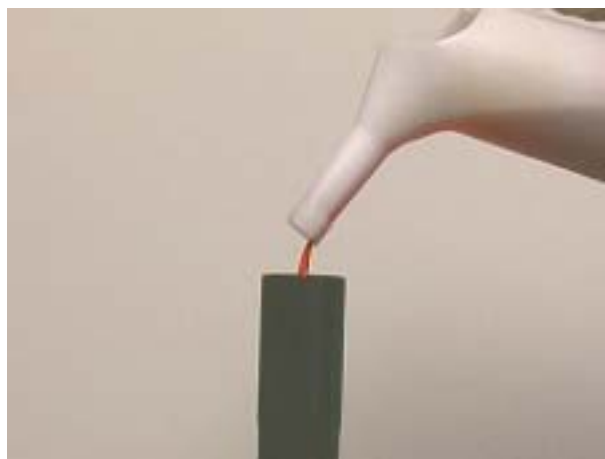

- Screw the top cap onto the cartridge leg



- Clamp the slider in a vice using the special tool



- Tighten the top cap to the specified torque



5.2.6. REPLACING THE OIL/DUST SEAL (RSV R)

- Clamp the slider with the specified tool.



- Set the spring preload to its minimum



- Undo the upper slider cap



- Clamp the fork end taking care not to damage it



- Fit the special tool to the spring coupling



- Push the tool downwards to compress the spring and install the tool spacer under the cartridge locknut



- Slacken off the cap using the locknut for leverage with a wrench fitted to the wrench seat



- Remove the entire cap assembly



- Remove the spacer and the washer
- Press downwards to compress the spring and extract the spacer



- Extract the spring coupling



- Drain the oil into a container and remove the spring



- Extract the washer and lower spacer



- Undo the cartridge retainer screw on the fork end



- Retain the centring bushing



- Extract the wiper seal from the slider with a screwdriver
- Take care not to damage the rim of the slider



- Remove the stop ring



- Extract the slider from the stanchion tube using the slider itself to exert leverage



- Remove the fixed bushing, mobile bushing, ring and oil seal from the stanchion tube





- Remove the ring and wiper seal



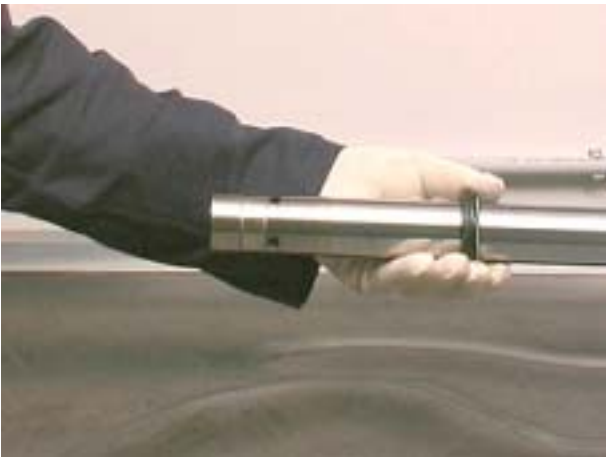

5.2.7. REFITTING THE OIL/DUST SEAL (RSV R)

- Clamp the fork leg in such a way as not to damage it.
- Protect the end of the stanchion tube with tape.
- Lubricate the sliding surfaces with fork oil or seal grease.

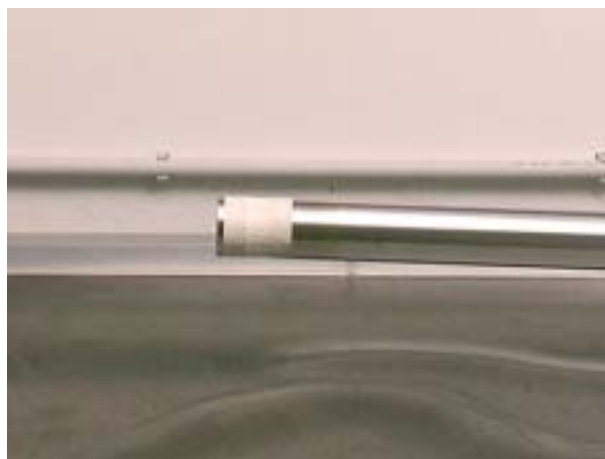

- Fit the wiper seal, stop ring and seal ring to the stanchion tube.



- The seal ring must be installed with the stamped side facing the wiper seal



- Now fit the ring, mobile bushing and, after removing the tape, the fixed bushing



- Fit the slider to the stem and install the oil seal in its correct position with the special tool



- Fit the stop ring in its seat



- Fit the wiper seal with the prescribed tool



- Fit the centring bushing to the cartridge and install the entire assembly to the fork



- Tighten the cartridge retainer screw on the fork end to the specified torque



- Fit the lower spacer and washer



- Install the fork spring



- Fill the fork so that any air inside it is vented

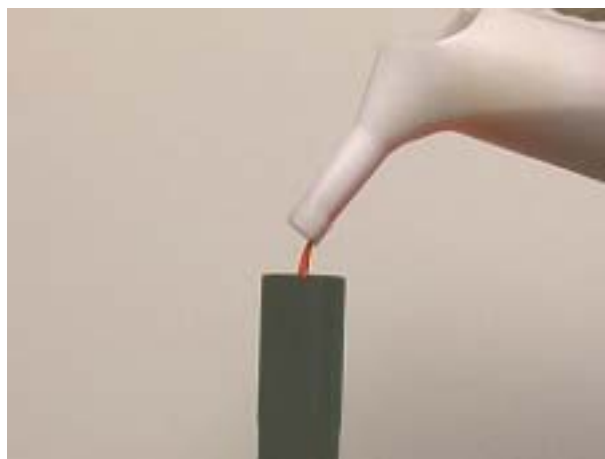

- Fit the spring coupling



- Fit the special tool to the spring coupling so as to lock the cartridge stem in position



- Fit the spacer and washer



- Screw the top cap onto the cartridge leg



- Clamp the slider in a vice using the special tool



- Tighten the top cap to the specified torque



5.2.8. CHECKING THE COMPONENTS**WHEEL-HOLDER TUBE**

Check the sliding surface, which must be neither lined, nor scratched.

Slight lines can be eliminated by sanding the surface with wet sandpaper (grain 1).

If the lines are deep, change the tube.

By means of a comparator, make sure that any curving of the tube be lower than the limit value.

If it exceeds the limit value, change the tube.

Curving limit: 0.2 mm.

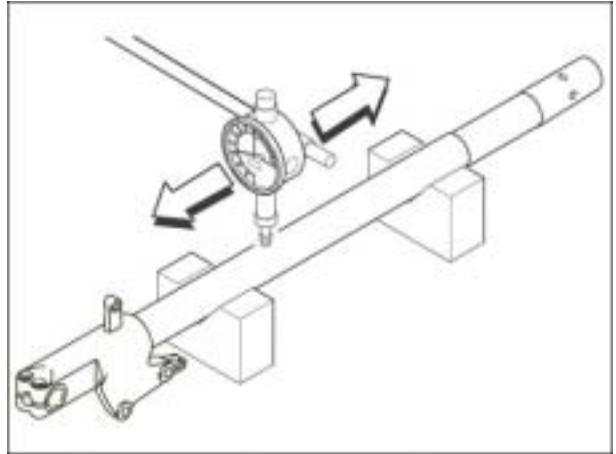
**WARNING**

NEVER straighten a curved tube, since its structure would be weakened, thus making the use of the vehicle quite dangerous.

SLIDER

Make sure that there are neither damages, nor cracks.

Otherwise, change it.

SPRING

Check the integrity of the spring, making sure that its length does not exceed the limit value.

If the length does not correspond to the limit value, change the spring.



Minimum length of the spring when not compressed: 284 mm.

Check the condition of the following components:

- slide bushing;
- guide bushing;



- pumping element.
- If excessive wear or any damage are observed, change the component in question.



CAUTION
Remove any accumulation of impurities from the bushings, taking care not to scratch their surfaces.

Replace the following components with new ones:

- gasket;
- antidust gasket;



- the two O rings on the adjusting element.

Oil quantity: 520 ± 2.5 cm₃.

Oil level: 118 ± 2 mm (from the slider edge).

NOTE In order to obtain a correct measurement of the oil level, the slider must be perfectly vertical. The oil level must be the same for both tubes.

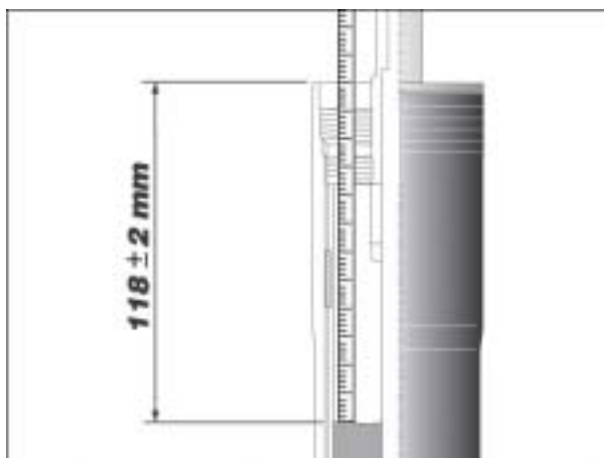

FORK RSV R

Factory setting is designed for any riding condition, low or high speed, with reduced or full load. However, front suspension setting may be modified to suit specific needs in accordance with vehicle use.

WARNING
 Before adjusting, first set the fork to the stiffest setting [turn the adjusters (1-2) fully clockwise]. The notches on the adjusters (1-2) provide convenient reference marks when setting compression and rebound damping. Rotate the adjusters (1-2) gradually changing setting by one eighth of a turn at a time.

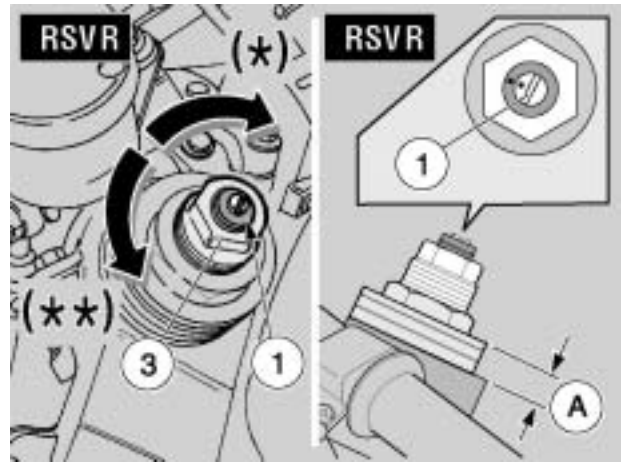

CAUTION
 Racing settings may only be used during official competitions or sports events authorised by the competent authorities and taking place in closed circuits or, anyway, away from public roads. Riding a vehicle with racing settings on public roads and highways is forbidden by the law.

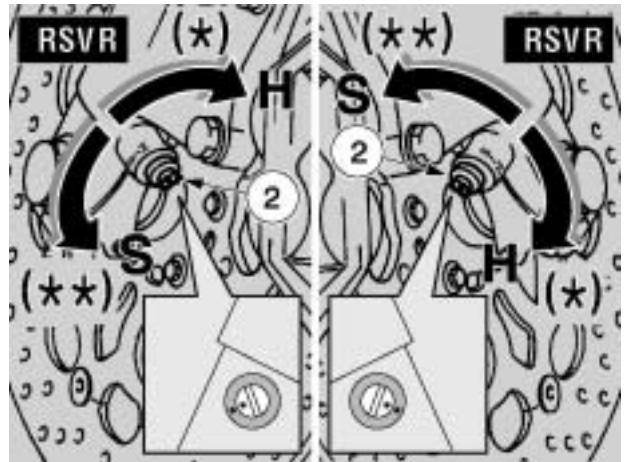

Front suspension	Standard setting	Racing setting
Hydraulic rebound damping, screw (1)	Tighten fully (*) and then slacken (**) by 1.25 turn	Tighten fully (*) and then slacken (**) by 0.5 - 1 turn
Hydraulic compression damping, screw (2)	Tighten fully (*) (H) and then slacken (**) (S) by 1 turn	Tighten fully (*) (H) and then slacken (**) (S) by 0.5 - 1 turn
Spring preload, nut (3)	Tighten fully (*) and then slacken (**) until 4 - 5 notches are in view	
Fork height (A) (***) over top yoke (not including top cap)	4 notches in view	5 notches in view

(*) clockwise
 (**) anticlockwise
 (***) Have this adjustment carried out exclusively by an **aprilia** Official dealer

“R FACTORY” FORK (RSV R OPT)

Factory setting is designed for racing. However, front suspension setting may be modified to suit specific needs in accordance with vehicle usage.



WARNING

Before adjusting, first set the fork to the stiffest setting [turn the adjusters (1-2) fully clockwise]. The notches on the adjusters (1-2) provide convenient reference marks when setting compression and rebound damping. Rotate the adjusters (1-2) gradually changing setting by one notch at a time.

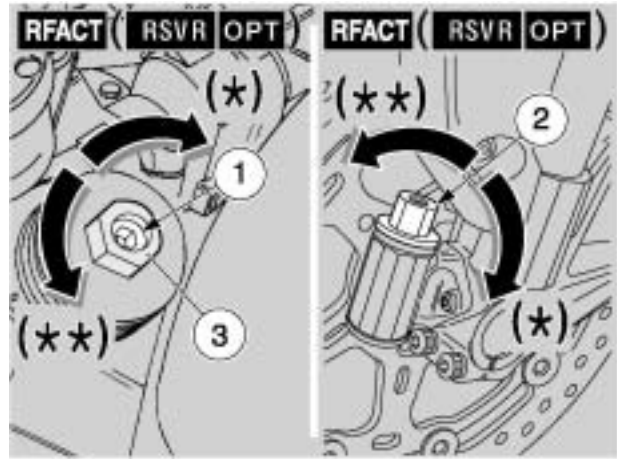

CAUTION

Racing settings may only be used during official competitions or sports events authorised by the competent authorities and taking place in closed circuits or, anyway, away from public roads.

Riding a vehicle with racing settings on public roads and highways is forbidden by the law.

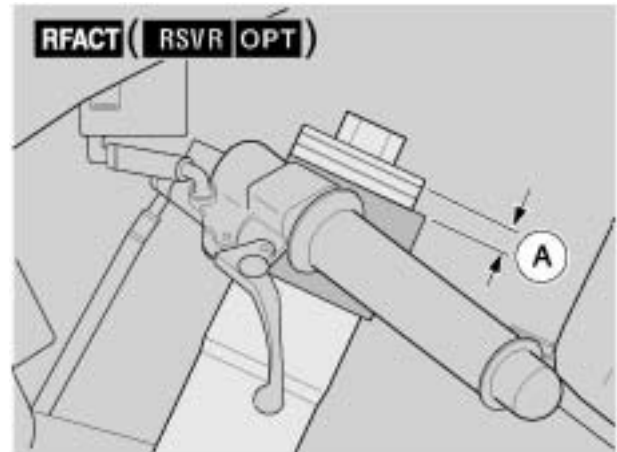

Front suspension	Standard setting	Racing setting
Hydraulic rebound damping, screw (1)	Tighten fully (*) and then slacken (**) by 12 click positions	Tighten fully (*) and then slacken (**) by 8 - 10 click positions
Hydraulic compression damping, screw (2)		
Spring preload, nut (3)	Slacken fully (**) and then tighten (*) by 8 turns	Slacken fully (**) and then tighten (*) by 6 - 9 turns
Fork height (A) (***) over top yoke (not including top cap)	4 notches in view	5 notches in view

(*) clockwise

(**) anticlockwise

(***) Have this adjustment carried out exclusively by an aprilia Official dealer

5.2.9. FRONT FORK DIAGRAM (RSV FACT)

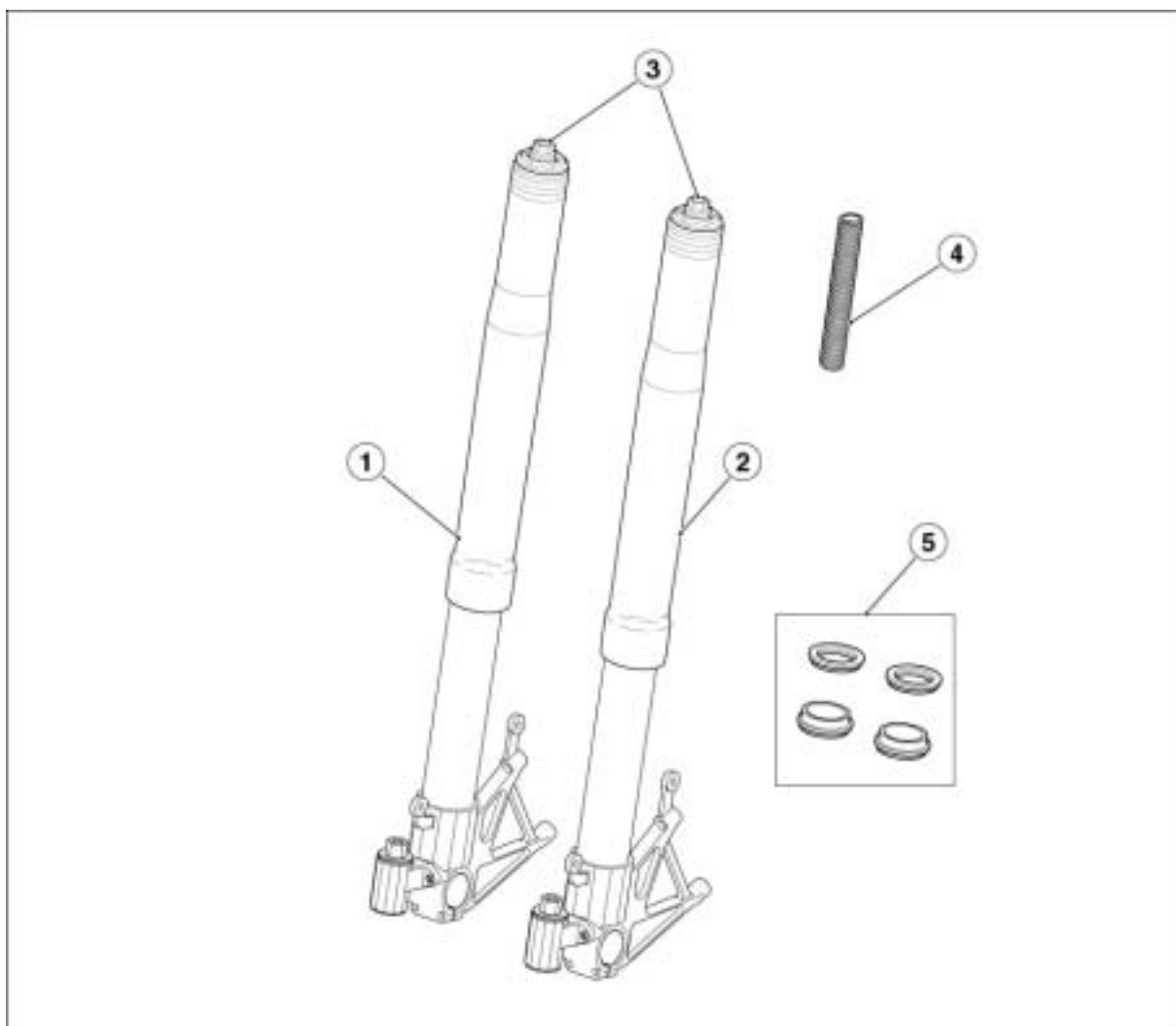
**Key:**

1. Complete RH fork leg
2. Complete LH fork leg
3. Top cap
4. Spring
5. Fork overhaul kit

5.2.10. CHANGING THE FORK FLUID (RSV FACT)

NOTE The same internal components are used in both fork legs. The procedures described below apply to both fork legs.

- Remove the stanchion tube-slider assembly.
- Clean stanchion and slider thoroughly.

NOTE Make sure to have the special tools A (no.8140424) and B (no.8140149) and a container having a capacity greater than 550 cu. cm. ready at hand before proceeding.

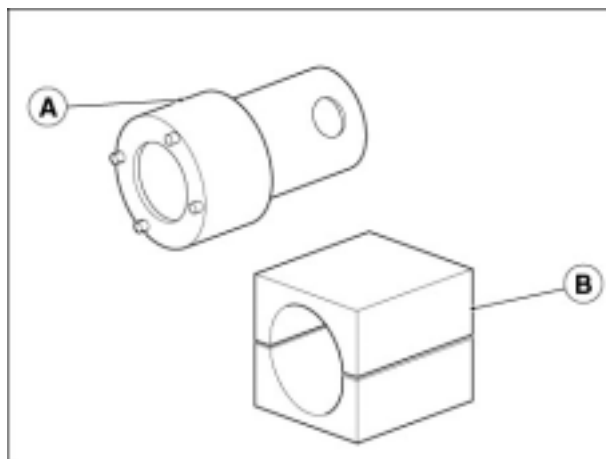

- Place the stanchion-and-slider assembly in a vice. Position the two shells of the special tool (B) to the vice jaws to protect the stanchion-and-slider assembly.
- Turn the top adjuster screw (1) fully anti-clockwise to reduce rebound damping force.
- Turn the spring preload top nut (2) fully anti-clockwise.



- Release the top cap (3) from the slider using the special tool (A).



- Push down the spacer tube (4) and fit a spanner to the nut to lock out damping cylinder rotation.
- Release and remove the top cap (3) while holding the damping cylinder with the spanner.
- Remove the spacer tube (4).



RSV 1000 R - RSV 1000 R FACTORY

- Remove the stanchion and slider assembly (5) from the vice.
- Turn stanchion and slider over (5) to drain oil into the container.

NOTE Make sure the damping cylinder rod does not come out while draining oil.



5.2.11. TOPPING UP THE FORK FLUID (RSV FACT)

NOTE Make sure to have the special tools A (no.8140424) and B (no.8140149) ready at hand before proceeding.

- Keep the stanchion and slider assembly upright and fit the two shells of the special tool (B).

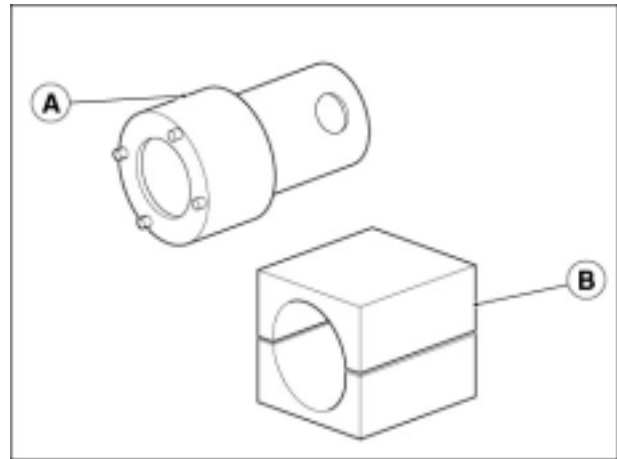

- Raise the washer and the damping cylinder assembly.



- Fill the fork with the specified fluid, up to correct level. Use a dipstick to determine correct level.

Oil quantity: 500 cu cm.

Oil level: 85 mm (from slider rim).



- Accurate oil level measurement is only ensured when the slider is perfectly vertical and fully down. Oil level must be the same in both fork legs.



- Grasp the damping cylinder assembly (1) and pump it up and down a dozen of times to expel any air inside.
- Allow several minutes and measure oil level again. If necessary, top up or remove oil until oil is at the correct level (n.d.r. 85 mm).



- Insert the spacer tube (2).



- Tighten the top cap (3) onto the damping cylinder assembly until finger tight.
- Hold the damping cylinder steady with a spanner and tighten the top cap (3).



- Use the special tool (A) to tighten the top cap (3) onto the slider.
- Adjust to obtain correct setting.



5.2.12. REPLACING THE OIL/DUST SEAL (RSV FACT)

REMOVAL

NOTE Make sure to have the special tools B (no. 8140149), C (no. 8140189), and D (no. 8140146) ready at hand before proceeding.

- Perform the first nine steps of the procedure described at paragraph (FRONT FORK OIL CHANGE).

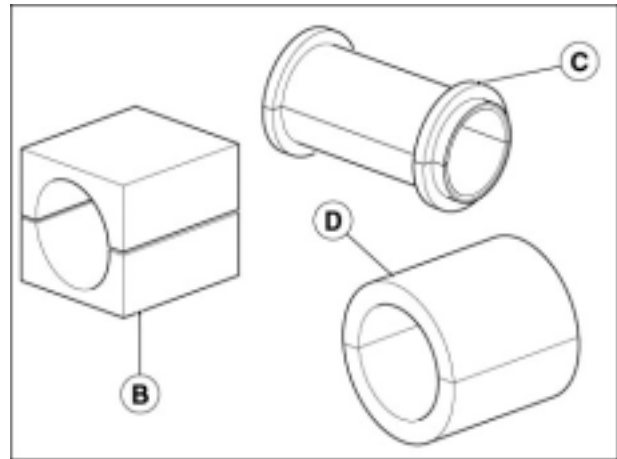

- Place the fork leg in a vice. Position the two shells of the special tool (B) to the vice to avoid damage.
- Separate the slider (2) from the stanchion tube (1).



- Prise the dust seal (3) off the slider (2) levering with a flat-blade screwdriver at various positions.



- Use the flat-blade screwdriver to remove the retaining ring (4).



NOTE Protect the slider edge with a rubber strip to avoid denting during removal of the oil seal (5).

- Prise out the oil seal (5) using a flat-blade screwdriver.

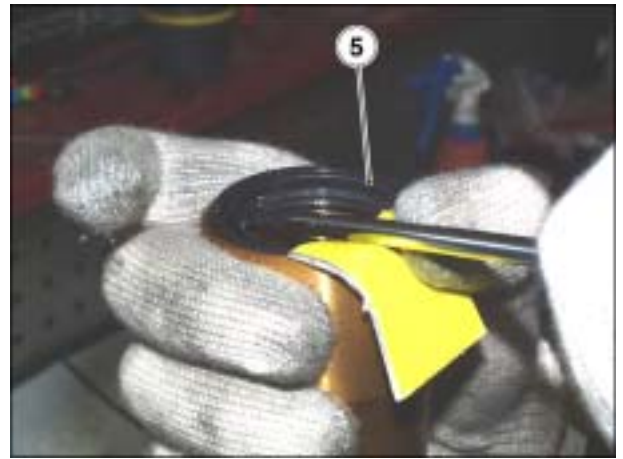

REFITTING



WARNING

Be careful to prevent dirt from entering slider or stanchion.
Never reuse the fork fluid.

Renew:

- oil seal (5)
- dust seal (3)

NOTE Smear the oil seal (5) lightly with fork fluid before installation.

- Fit the following components to the stanchion (1) in the order: dust seal (3), retaining ring (4) and oil seal (5).
- Place the slider in a vice and protect it with the two shells of the special tool (B).
- Insert the stanchion (1) into the slider (2).



- Position the two shells of the special tool (B - C) to the stanchion (1), just below the oil seal (5).
- Grasp the special tool (B - C) and push to drive the oil seal (5) into place in the slider (2).
- Remove the tool (B - C).



- Insert the retaining ring (4) into its groove in the slider (2).



- Push the dust seal (3) into its seat in the slider (2) and ensure it becomes properly seated.
- Grasp the stanchion and pump it up and down slowly several times.

**WARNING**

The stanchion must slide freely in the slider, in a smooth motion.

- Pour front fork fluid into the fork leg up to correct level.



5.2.13. TIGHTENING TORQUES

DESIGNATION	QUANTITY	SCREW / NUT	TORQUE (Nm)	NOTES
FRONT SUSPENSION				
Front fork				
Fork leg / top yoke	1+1	M8	25	-
Fork leg / bottom yoke mount	2+2	M8	25	-
Head stock nut (first tighten and then slacken off)	1	M35x1	40	first tighten and then slacken off
Head stock nut (second tighten down)	1	M35x1	20	second tighten down
Head stock locknut	1	M35x1	man. + 90 degrees	-
Top yoke cap	1	M29x1	100	-
SHOWA fork hub clamps	2+2	M8	22	-
OHLINS fork hub clamps	2+2	M6	12	-
Steering damper				
Steering damper collar frame	1	M6	10	Loctite 243
Steering damper rod bottom yoke	1	M6	10	-

5.3. STEERING BEARING

5.3.1. DIAGRAM

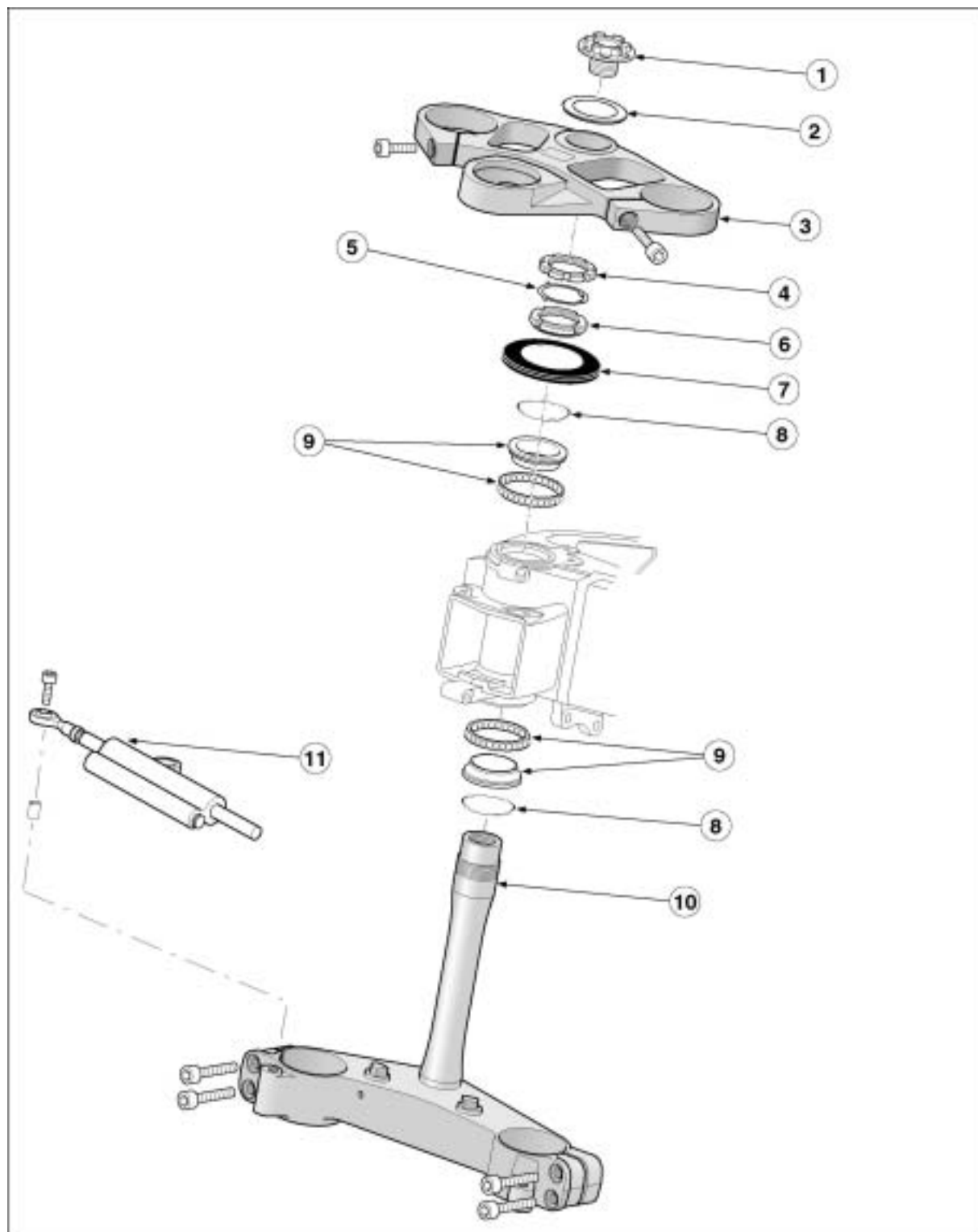

Key:

1. Upper bush
2. Washer
3. Upper plate
4. Lock ring
5. Lock washer
6. Adjuster ring
7. Antidust gasket
8. Antidust gasket
9. Bearings
10. Lower plate
11. Steering damper

5.3.2. CHECKING THE BEARING SLACK STEERING**Steering bearings and steering clearance:**

- Position the vehicle on the special centre stand.
- Shake the fork in the direction of travel.
- In the event any slack is encountered, adjust the steering.

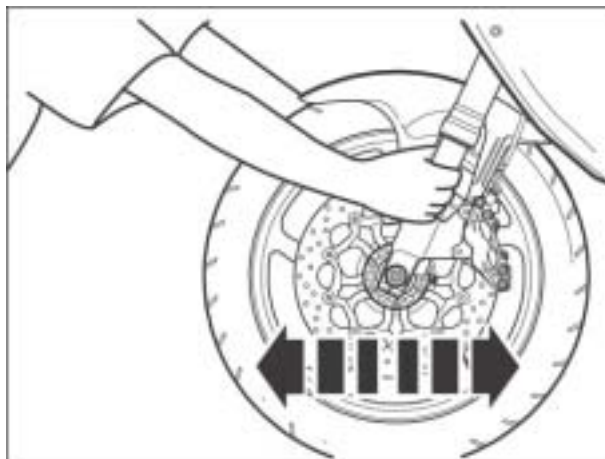

5.3.3. STEERING BEARING ADJUSTMENT

- Undo the upper steering column bolt.
- Slacken off the screws securing the fork legs to the upper yoke.
- Undo and remove the screws uniting the handlebar halves and fork yoke.
- Extract the upper yoke and move it towards the dashboard



- Settle the safety washer on the steering column



- Unscrew the upper ring nut and remove the safety washer



- Adjust the steering bearing preload by tightening the lower ring nut to the specified torque.



- Position the safety washer



- Install the upper ring nut and tighten it so that the grooves fit over the safety washer keys



- Settle the lugs on the upper ring nut



- Fit the upper yoke



- Fit and tighten the upper steering column bolt to the specified torque



- Tighten the screws uniting the handlebar halves and fork yoke to the specified torque



- Tighten the screws securing the fork stems to the upper yoke to the specified torque



5.3.4. TIGHTENING TORQUES

DESIGNATION	QUANTITY	SCREW / NUT	TORQUE (Nm)	NOTES
FRONT SUSPENSION				
Front fork				
Fork leg / top yoke	1+1	M8	25	-
Fork leg / bottom yoke mount	2+2	M8	25	-
Head stock nut (first tighten and then slacken off)	1	M35x1	40	first tighten and then slacken off
Head stock nut (second tighten down)	1	M35x1	20	second tighten down
Head stock locknut	1	M35x1	man. + 90 degrees	-
Top yoke cap	1	M29x1	100	-
SHOWA fork hub clamps	2+2	M8	22	-
OHLINS fork hub clamps	2+2	M6	12	-
Steering damper				
Steering damper collar frame	1	M6	10	Loctite 243
Steering damper rod bottom yoke	1	M6	10	-

5.4. REAR SUSPENSION

5.4.1. DIAGRAM

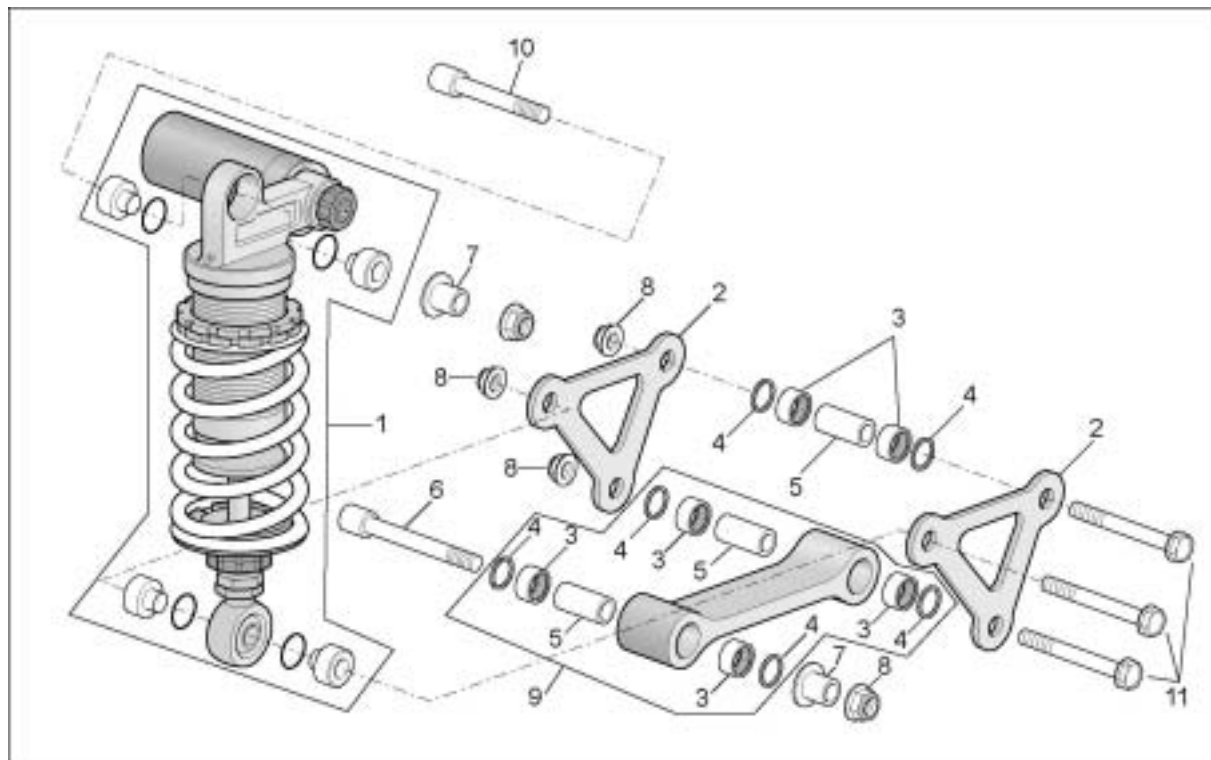
**Key:**

1. Shock absorber
2. Double conrod
3. Needle bearing
4. Oil seal
5. Piston pin
6. Screw
7. T bush
8. Self-locking nut
9. Single conrod comp.
10. Hex socket screw
11. Screw w/ flange

5.4.2. REMOVING THE REAR SUSPENSION

- Support the rear end of the motorcycle
- Undo the clips uniting the lower seat subframe panels.
- Move the fuel lines away from the area over the rear suspension assembly
- Undo the two screws securing the panel to the frame



- Remove the panel and extract the cable bundles



- Undo the nuts on the double connecting rods



- Undo the screws and remove the double connecting rods



- Undo the screw on the rear suspension upper mount



- Undo the screw and extract the rear suspension from its seat by rotating it





5.4.3. CHECKING THE COMPONENTS



CAUTION
 Make sure that none of the components appear to be visibly distorted, broken, cracked and/or dented. Replace any damaged components

BEARINGS

Manually rotate the rollers. It should rotate smoothly without jamming and/or noise. There should be no end play. Any bearings featuring said defects should be changed.



CAUTION
 Apply grease on the rollers.

SEALS

Make sure the seals are intact; should they prove damaged or feature signs of excessive wear, change them.

SHOCK ABSORBER

Make sure that there are no oil leaks from the shock absorber and that its travel is smooth and gradual. If this is not the case, change the shock absorber.



WARNING
 The shock absorber contains pressurized nitrogen. In order to avoid the risk of an explosion, keep it away from flames and/or sources of heat. In the event the shock absorber is to be re-placed, discharge the nitrogen by pressing the central core of the valve under the cap or under the screw.



Rear suspension	Standard setting	Racing setting
Shock absorber distance between centres (A)	313 ±1.5 mm	310 to 317 mm
Spring length (preloaded) (B)	RSV R 149 mm - RFACT 145 mm	RSV R 151 mm- RFACT 147 mm
Rebound damping, ring nut (1)	Tighten fully (*) and then slacken (**) by 20 click positions	Tighten fully (*) and then slacken (**): - RSV R by 12 - 16 click positions - RFACT by 13 - 16 click positions
Compression damping, screw (2) for RSV R , or knob (2) for RFACT	Tighten fully (*) and then slacken (**) - RSV R by 1.5 turns - RFACT by 12 click positions	Tighten fully (*) and then slacken (**) - RSV R by 1-2 turns - RFACT by 8-14 click positions

(*) clockwise
 (**) anticlockwise

**CAUTION**

Racing settings may only be used during official competitions or sports events authorised by the competent authorities and taking place in closed circuits or, anyway, away from public roads. Riding a vehicle with racing settings on public roads and highways is forbidden by the law.

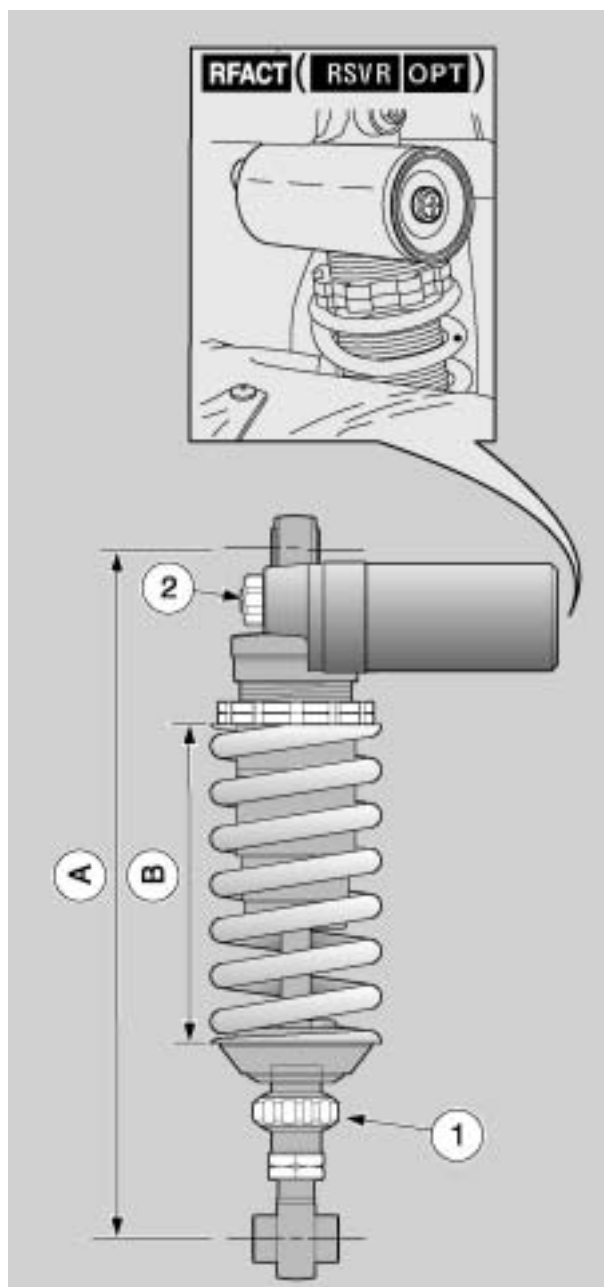

5.4.4. REFITTING THE REAR SUSPENSION

- Fit the rear suspension into its seat
- Fit the upper suspension mounting screw
- Tighten the screw to the specified torque
- Fit the right hand double connecting rod together with the screw on the rear suspension mount



- Install the remaining screws to the double connecting rod



- Fit the left hand double connecting rod



- Tighten all screws to their specified torque



- Fit the panel onto the frame over the cable bundles



- Tighten the two screws securing the panel to the frame to the specified torque
- Fit the clips uniting the lower seat subframe panels



5.4.5. DISASSEMBLING THE REAR SUSPENSION LINKAGE

- Working from the right-hand side of the vehicle, loosen and remove the nut (1).
- Pull the screw (2) out from the opposite side.
- Loosen and remove the nut (3).
- Pull the screw (4) out from the opposite side.
- Loosen and remove the nut (5).
- Pull the screw (6) out from the opposite side.
- Remove the whole suspension linkage unit (7).

NOTE When reassembling, grease the linkage fulcrum points, and be extremely careful to refit the components correctly, making sure that the joints move smoothly.

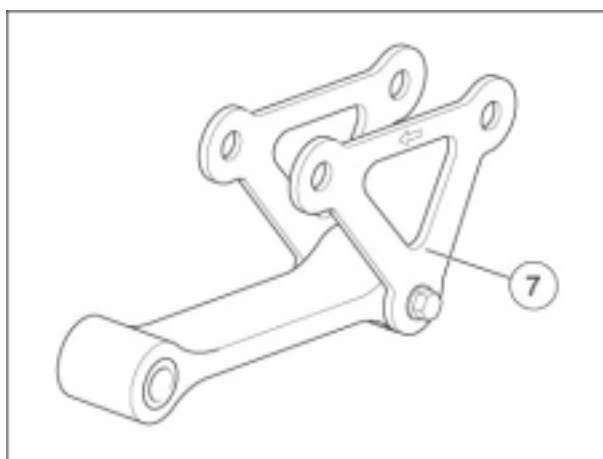

5.4.6. TIGHTENING TORQUES

DESIGNATION	QUANTITY	SCREW / NUT	TORQUE (Nm)	NOTES
REAR SUSPENSION				
Shock absorber				
Shock absorber frame	1	M10	50	-
Linkages				
Single connecting link frame	1	M10	50	-
Single / double connecting link	1	M10	50	-
Double connecting link swinging arm	1	M10	50	-
Double connecting link shock absorber	1	M10	50	-

5.5. SWINGING ARM

5.5.1. REMOVING THE SWINGING ARM

- Position the vehicle on its centre stand (OPT).
- Remove the rear wheel.

IMPORTANT Although not required for removing the rear wheel, the rear stand (OPT) is necessary for supporting the swinging arm without the wheel mounted.

Shim out the rear stand base (OPT) to bring it into position (engaged with the two pawls on the swinging arm itself).



- Remove the exhaust assembly.
- Undo and remove the three screws securing the cover and collect the washers.



- Move the mount plate complete with brake calliper and speed sensor (connected to their hose and cable respectively) carefully to one side and rest it on the ground.



WARNING

Do not operate the rear brake lever with the brake calliper removed, or the brake calliper piston might fall out leading to loss of brake fluid.



- From the LH side, release and remove the double connecting link / swinging arm nut.
- Extract the screw from the other side.



- From the LH side, release and remove the lower shock absorber nut.
- Extract the screw from the other side.



- Release and remove the nut and collect its washer.



IMPORTANT Make sure to use the special tool (OPT):

- **aprilia** part# 8140191 (swinging arm spindle / engine stand tool).
- Using the provided socket wrench, slacken and remove the locknut (1) from the RH side of the vehicle.



- Turn the swinging arm spindle (2) counterclockwise to rotate the adjuster bush (3) and thus loosen it.



WARNING

Take great care when removing the swinging arm.
Support it at the front to prevent it from dropping.
Place a wooden support beneath the front of the swinging arm to keep it from dropping or moving.



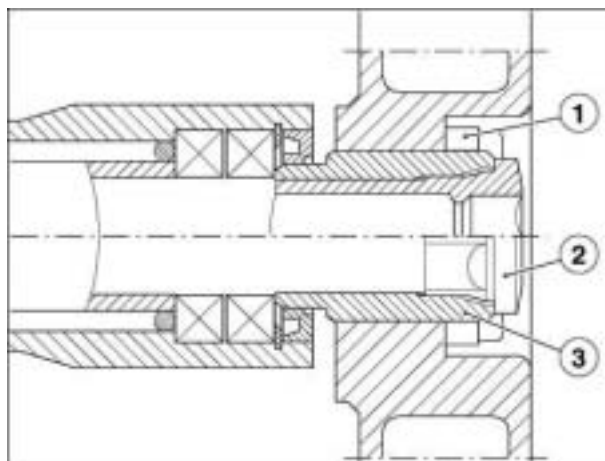

- Place a support beneath the front of the swinging arm.
- Support the front of the swinging arm.
- Extract the swinging arm spindle (2) from the right-hand side.

**WARNING**

Make sure the transmission chain does not get entangled when removing the swinging arm.

- Support the front of the swinging arm and prepare to hold it as it moves.
- Using the rear stand, slide the swinging arm out from the rear of the vehicle.
- Extract the swinging arm spindle (2) and adjuster bush (3).

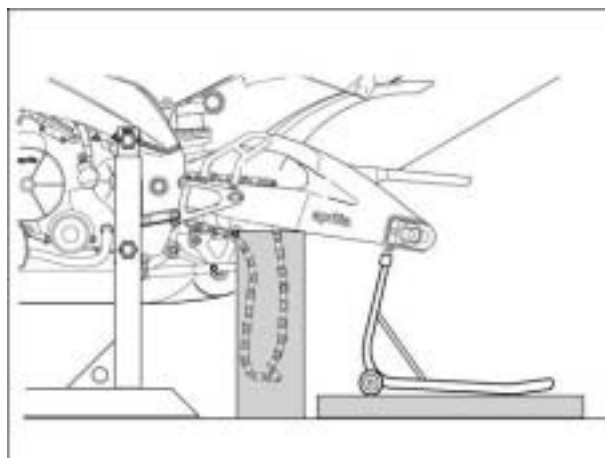

5.5.2. CHECKING THE COMPONENTS



CAUTION
Make sure that all the components are intact, particularly the following.

REAR FORK BEARINGS

Carry out the check with the bearings mounted on the rear fork.

CHECKING THE ROTATION

- Manually rotate the inner ring of each single bearing. The rotation must be regular, smooth and noiseless.

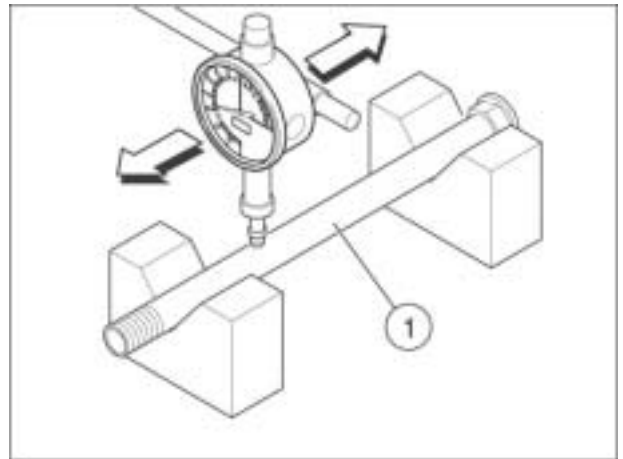

If one or both bearings is/are not in compliance with the check parameters:

- Change both rear fork bearings.



WARNING
Always change both bearings.
Always replace the bearings with bearings of the same type.

CHECKING THE END AND RADIAL PLAY

- Check the radial play and the end play.
End play: a minimum end play is allowed.
Radial play: none.

If one or both bearings is/are not in compliance with the check parameters:

- Change both rear fork bearings.



WARNING
Always change both bearings.
Always replace the bearings with bearings of the same type.

REAR FORK GASKETS

- Make sure the seals are intact; should they prove damaged or feature signs of excessive wear, change them.



WARNING
Always change both seals.
Always replace the gaskets with gaskets of the same type.

REAR FORK PIN

- Check the eccentricity of the fork pin (1) by means of a comparator. If the eccentricity exceeds the limit value, change the fork pin (1).

Maximum eccentricity: 0.3 mm.

5.5.3. DISASSEMBLING THE REAR FORK GASKETS

- Remove the fork.
- Use a cloth to clean both sides of the bearing housings.
- Slide out the bush (1).
- Remove the seal (2).
- Remove the seal (3).
- Remove the snap ring (4).

NOTE Have the appropriate special tool **OPT** to hand:
- **aprilia** part# 8140180 (bearing extractors).

- Use a special extractor to extract the two bearings (5) and roller bearing (6).

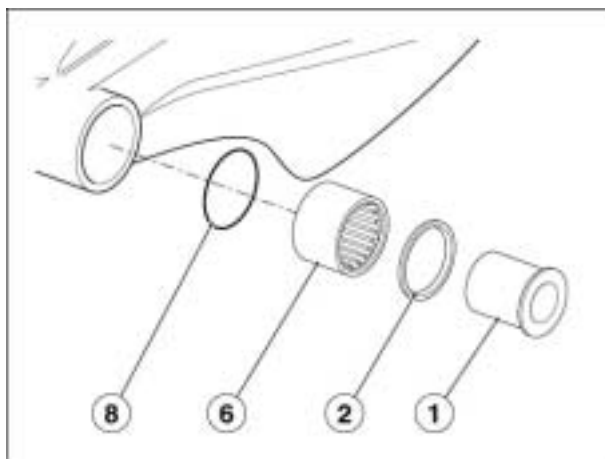
**CAUTION**

The bearings must be checked and, if necessary, changed every time they are disassembled.

- Remove the inner spacer (7) and retrieve the two O-rings (8).
- Remove the inner spacer (9).
- Remove the seals (10).
- Use a special extractor to extract the two roller bearings (11).

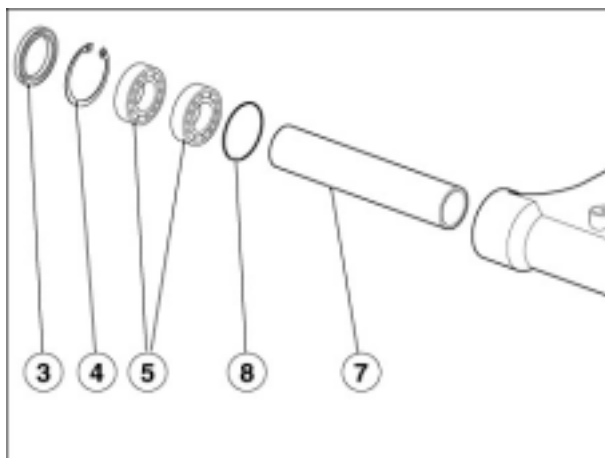
**CAUTION**

The bearings must be checked and, if necessary, changed every time they are disassembled.

- Thoroughly clean the inside of the bearing housing.

NOTE Wash all the components with a clean detergent.

**CAUTION**

When reassembling, use a drift with the same diameter as the outer race to insert the bearings.

Do not strike the balls and/or the inner race.

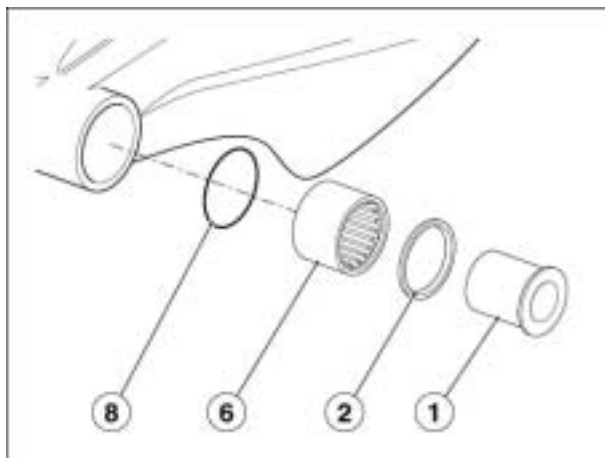

5.5.4. REFITTING THE SWINGING ARM

- Grease the entire length of the swinging arm spindle.
- Fit the adjuster bush (3) and hand tighten it.

IMPORTANT The adjuster bush (3) must not protrude beyond the frame's inner edge.

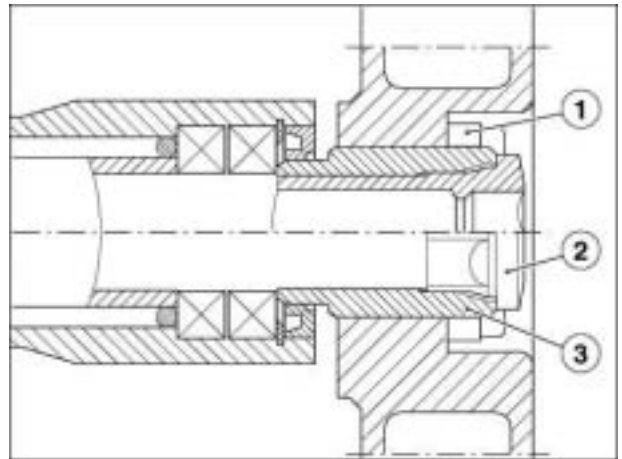

- Locate the transmission chain on the front (left) side of the swing arm and secure it with tape.
- Place a wooden support beneath the front of the swinging arm to keep it from dropping or moving.
- Support the rear of the swinging arm with its special rear stand (OPT).

IMPORTANT Shim out the rear stand base (OPT) to bring it into position (engaged with the two pawls on the swinging arm itself).

- Support the swinging arm at the front ; align the holes and fully insert the spindle (2).

IMPORTANT Make sure that the hexagonal section of the spindle head (2) is correctly seated into the hexagonal cavity in the adjuster bush (3).

- Fit and hand tighten the locknut (1) for a few turns.
- Fit the washer and nut (4) to the spindle, and hand tighten the nut.

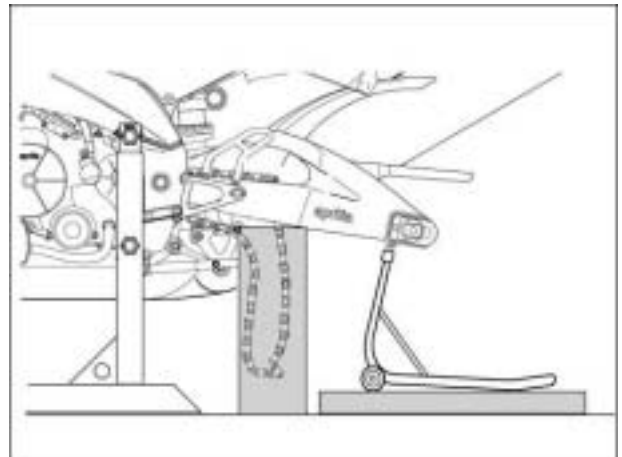

- Working from the right side of the vehicle, turn the swinging arm spindle (2) clockwise to rotate the adjuster bush (3) and thus seat the swinging arm itself.



IMPORTANT Make sure to use the special tool (OPT):

- **aprilia** part# 8140191 (swinging arm spindle / engine stand tool).
- Use the provided socket wrench to tighten the lock nut (1).



- Tighten the nut (4).



- Remove the tape holding the chain in place.
- Refit the chain to the pinion.

IMPORTANT When refitting, apply **LOCTITE®** Anti-Seize to the inner pinion toothing.

- Fit the pinion with chain mounted to the shaft.



IMPORTANT Apply **LOCTITE®** 243 to the screw thread.

- Fit the washer onto the screw.
- Tighten down the screw.



- Working from the right side, fit the lower shock absorber screw.
- Tighten down the nut from the opposite side.



- Working from the right side, fit the double connecting link / swinging arm screw.
- Tighten down the nut from the opposite side.



- Fit the mount plate complete with brake calliper and speed sensor.
- Tighten down the three screws securing the cover complete with washers.



- Fit the pinion cover and tighten down its three screws
- Refit the rear wheel and exhaust assembly.
- Adjust the tension of the transmission chain.



5.5.5. TIGHTENING TORQUES

DESIGNATION	QUANTITY	SCREW / NUT	TORQUE (Nm)	NOTES
SWINGING ARM				
Swinging arm spindle nut	1	M30x1,5	60	-
Swinging arm spindle adjuster bushing	1	M30x1,5	12	-
Swinging arm spindle nut	1	M20x1,5	90	-
Calliper mount pin	1	M12	50	Loctite 243
Chain tensioner screw and nut	1+1	M8	man.	-
Rear brake hose bracket	3	M5	4	-
Chain cover	2	M5	4	-
Chain shoe	2	M5	3	-
Plastic chain guide	1	M5	3	-
Rear stand bushing	2	M6	10	-
Plastic chain shoe (nut)	1	M6	10	-

DESIGNATION	QUANTITY	SCREW / NUT	TORQUE (Nm)	NOTES
REAR SUSPENSION				
Shock absorber				
Shock absorber frame	1	M10	50	-
Linkages				
Single connecting link frame	1	M10	50	-
Single / double connecting link	1	M10	50	-
Double connecting link swinging arm	1	M10	50	-
Double connecting link shock absorber	1	M10	50	-

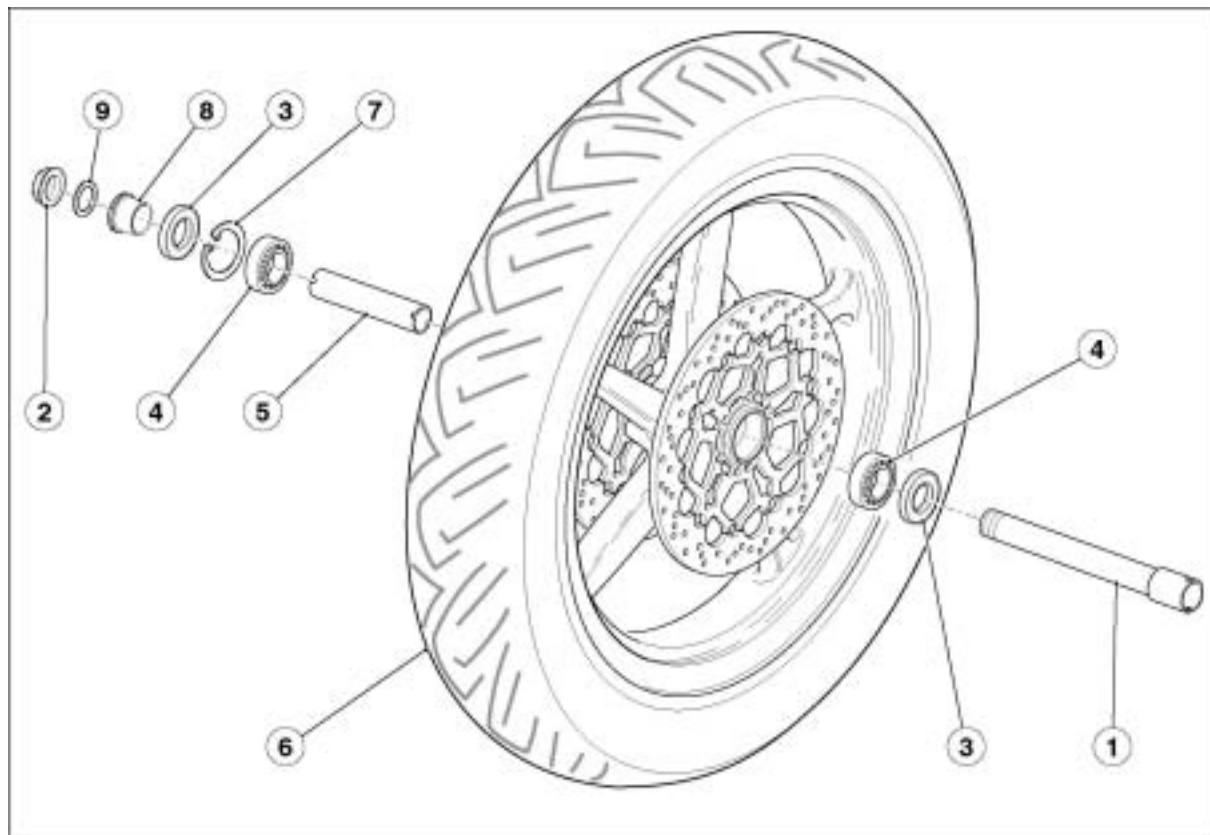
5.6. FRONT WHEEL**5.6.1. DIAGRAM****Key:**

1. Wheel pin
2. Nut
3. Seal
4. Bearing
5. Inner spacer
6. Complete wheel
7. Snap ring
8. Right spacer
9. Washer

5.6.2. REMOVING THE WHEEL

- Support the front part of the motorcycle.
- Undo the screws securing the front mudguard and remove it
- Undo the screws securing the front brake calipers and remove them from their seats
- Undo the nut retaining the wheel axle



- Retain the seal washer



- Slacken off the screws on the wheel axle clamps



- Lightly knock the wheel axle with a rubber mallet so as to uncover the holes on the opposite side



- Pull out the hollow axle using a screwdriver in the holes



- While removing the axle support the wheel, and then remove it



5.6.3. CHECKING THE FRONT WHEEL COMPONENTS



CAUTION

Make sure that all the components are intact, particularly the following.

FRONT WHEEL BEARINGS

Carry out the check with the bearings mounted on the wheel.

CHECKING THE ROTATION

- Manually rotate the inner ring of each single bearing. The rotation must be regular, smooth and noiseless.

If one or both bearings is/are not in compliance with the check parameters:

- Change both wheel bearings.



WARNING

Always change both bearings.
Always replace the bearings with bearings of the same type.

CHECKING THE END AND RADIAL PLAY

- Check the radial play and the end play.
End play: a minimum end play is allowed.
Radial play: none.

If one or both bearings is/are not in compliance with the check parameters:

- Change both wheel bearings.



WARNING

Always change both bearings.
Always replace the bearings with bearings of the same type.

FRONT WHEEL GASKETS

- Make sure the seals are intact; should they prove damaged or feature signs of excessive wear, change them.



WARNING

Always change both seals.
Always replace the gaskets with gaskets of the same type.

FRONT WHEEL PIN

- Check the eccentricity of the pin wheel (1) by means of a comparator. If the eccentricity exceeds the limit value, change the pin wheel (1).
Maximum eccentricity: 0.25 mm.

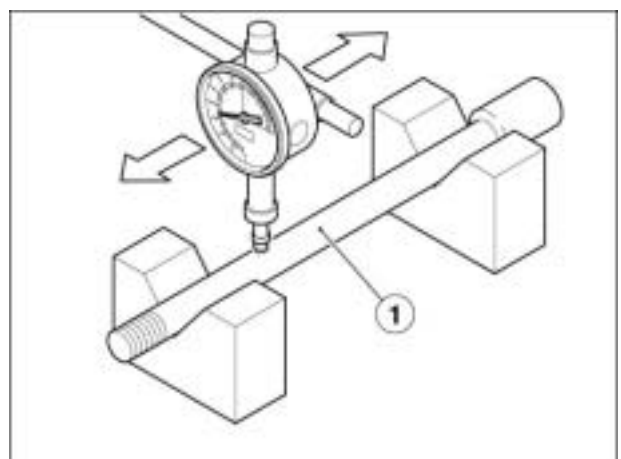

FRONT WHEEL RIM

- Using a comparator, make sure that the radial (A) and axial (B) eccentricity of the rim (2) do not exceed the limit value.
Excessive eccentricity is usually caused by worn or damaged bearings.
If, after changing the bearings, the value does not fall within the indicated limit, change the rim (2).
Maximum radial and axial eccentricity: 2 mm.

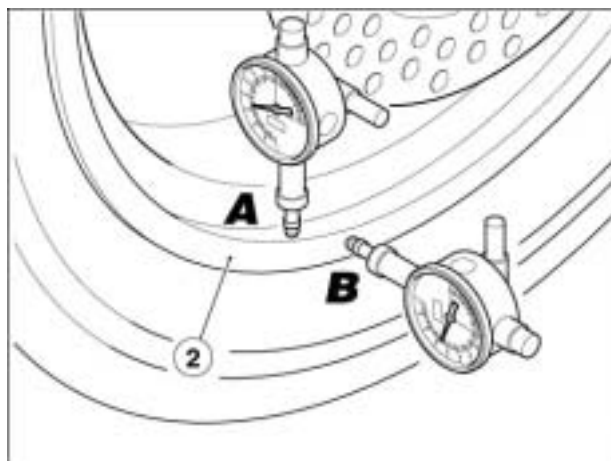

5.6.4. DISASSEMBLING THE FRONT WHEEL BEARINGS

- Remove the front wheel.
- Use a cloth to clean both sides of the hub.

Work on the right side of the wheel:

- Remove the right spacer (1).
- Remove the seal (2).
- Remove the snap ring (3).

NOTE The elastic ring (3) is provided only on the right side of the wheel.

The ends of the spacer (4) are provided with slots (A) to allow the passage of the extractor teeth.

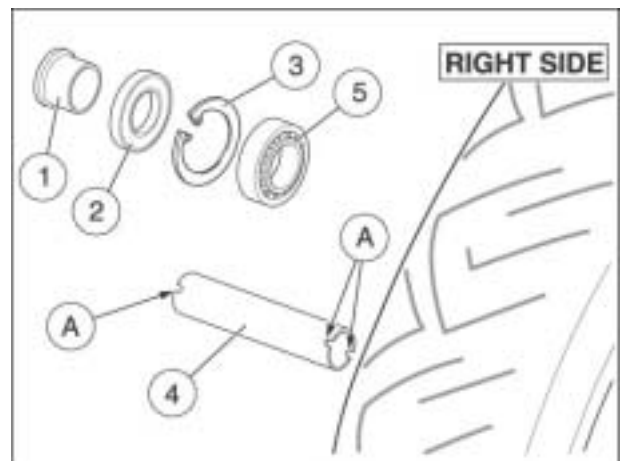

NOTE Have the appropriate special tool **OPT** to hand: - *aprilia* part# 8140180 (bearing extractors).

- Use a special extractor to extract the right bearing (5).
- Retrieve the inner spacer (4).

Work from the left-hand side of the wheel:

- Remove the seal (2).

NOTE Have the appropriate special tool **OPT** to hand: - *aprilia* part# 8140180 (bearing extractors).

- Use a special extractor to extract the left bearing (6).
- Thoroughly clean the inside of the hub.

NOTE Wash all the components with a clean detergent.

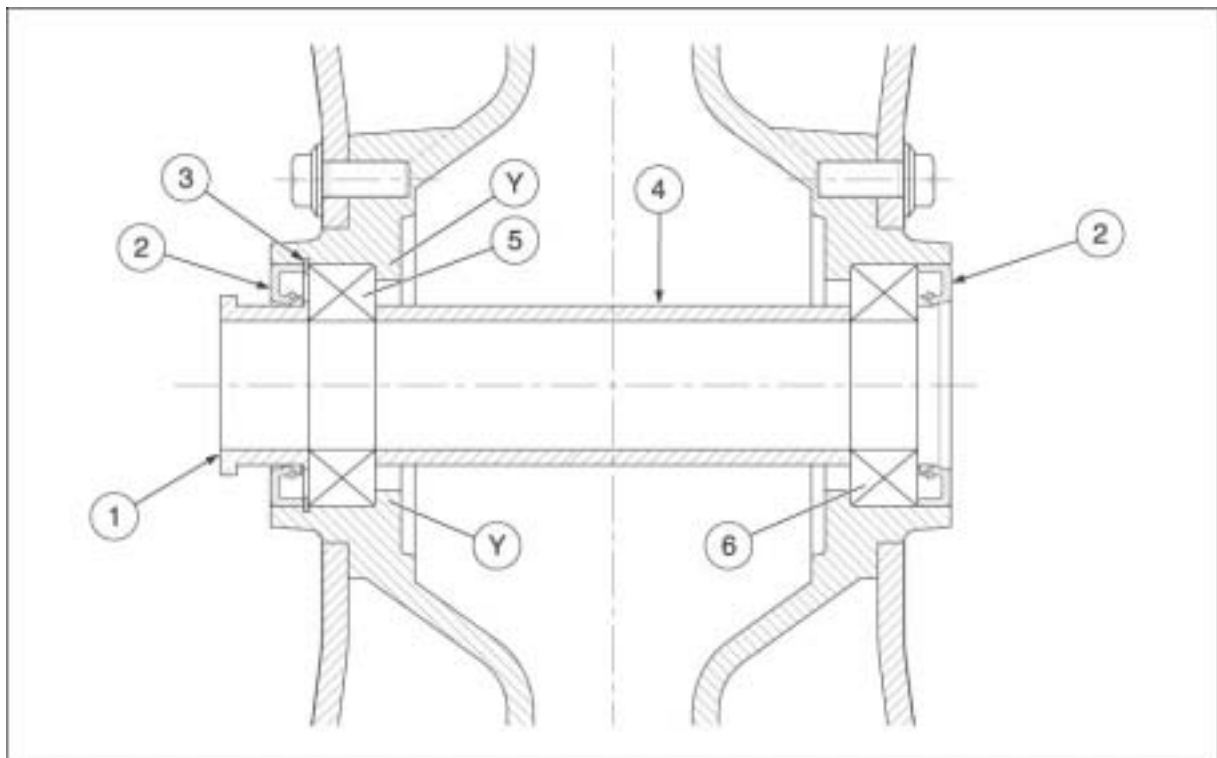
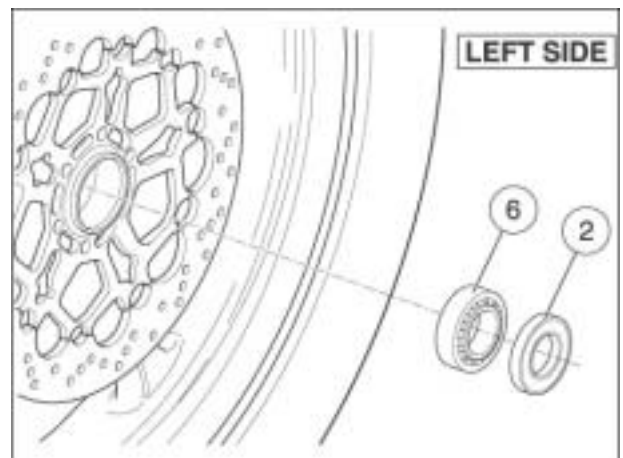

5.6.5. ASSEMBLING THE FRONT WHEEL BEARINGS

If provided:

- Remove the front wheel bearings.

Work on the right side of the wheel:

NOTE Have the appropriate special tool OPT to hand:
- **aprilia** part# 8140180 (bearing extractors).

- Using the appropriate pad, insert the right bearing (5) completely.

NOTE The right bearing must be inserted until its contact with the wheel hub shoulder is complete (Y).

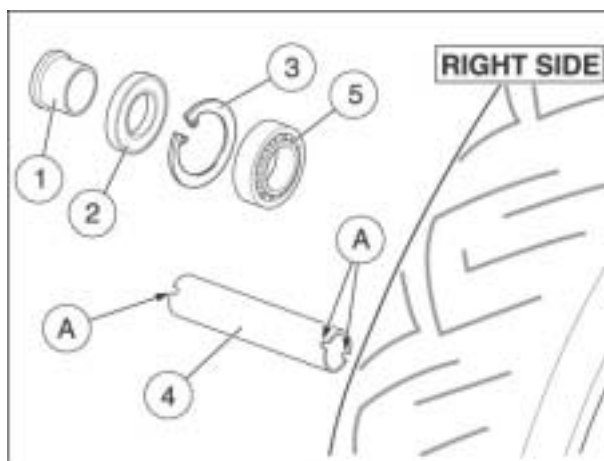

- Insert the elastic ring (3).

NOTE The elastic ring (3) is provided only on the right side of the wheel.

Work from the left-hand side of the wheel:

- Insert the spacer (4).

NOTE Have the appropriate special tool OPT to hand:
- **aprilia** part# 8140180 (bearing extractors).

- Use a special pad to insert the left bearing (6).

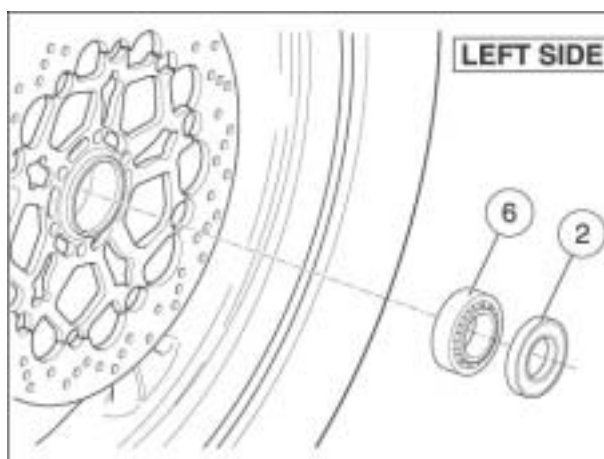

NOTE The complete insertion of the left bearing (6) will bring the following components into contact:

- right bearing (5);
- spacer (4);
- left bearing (6).

**CAUTION**

After the contact with the right bearing (5) do not push further, in order to avoid forcing the snap ring (3).

NOTE Once the left bearing (6) has been inserted, check the coaxiality of the following components:

- right bearing (5);
- spacer (4);
- left bearing (6).

- Install a new seal (2).

Work on the right side of the wheel:

- Install a new seal (2).
- Insert the spacer ring (1) with its longer diameter towards the outside of the vehicle.

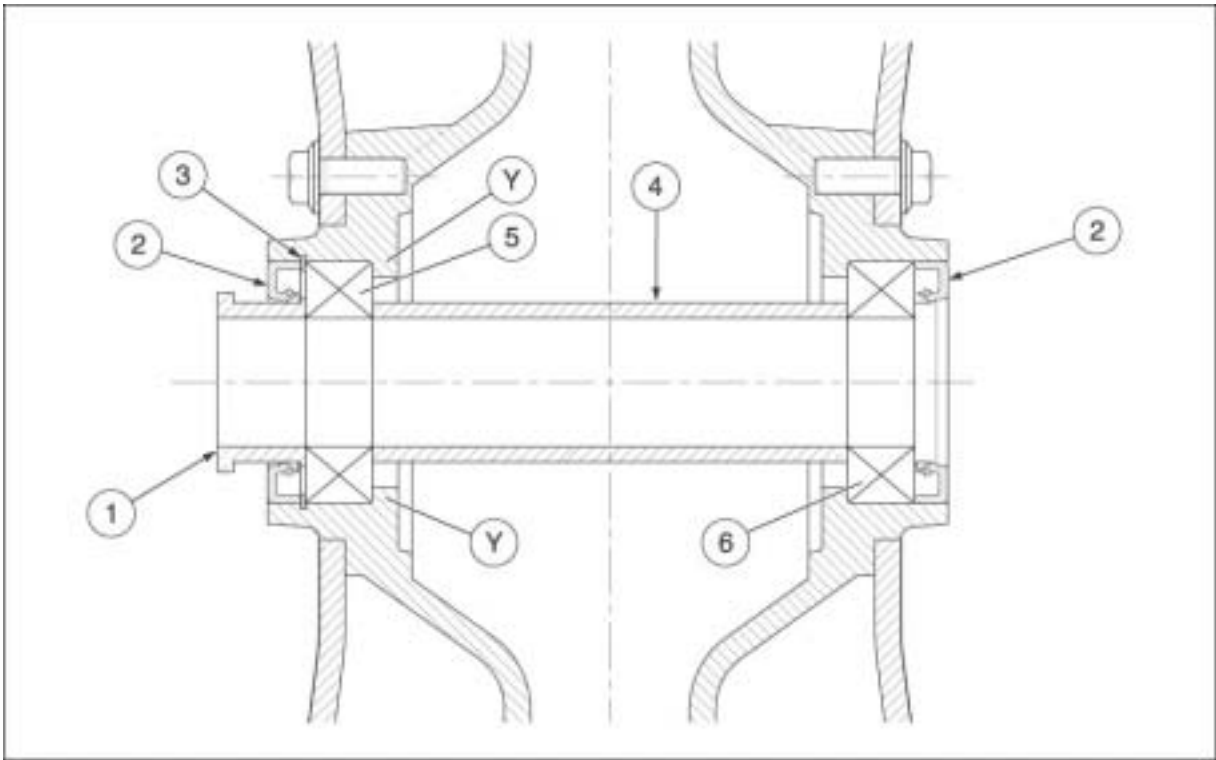

5.6.6. REFITTING THE FRONT WHEEL

- Fit the front wheel
- Fit the wheel axle
- Tighten down the clamp screws (nut side) to secure the wheel axle
- Fit the seal washer and screw on the axle nut to the specified torque
- Make sure the fork legs are aligned by pumping the fork up and down





- Tighten the screws securing the wheel axle clamps to the specified torque



- Tighten the screws securing it to the specified torque



WARNING
After fitting the brake callipers repeatedly operate the front brake lever



5.7. REAR WHEEL

5.7.1. DIAGRAM

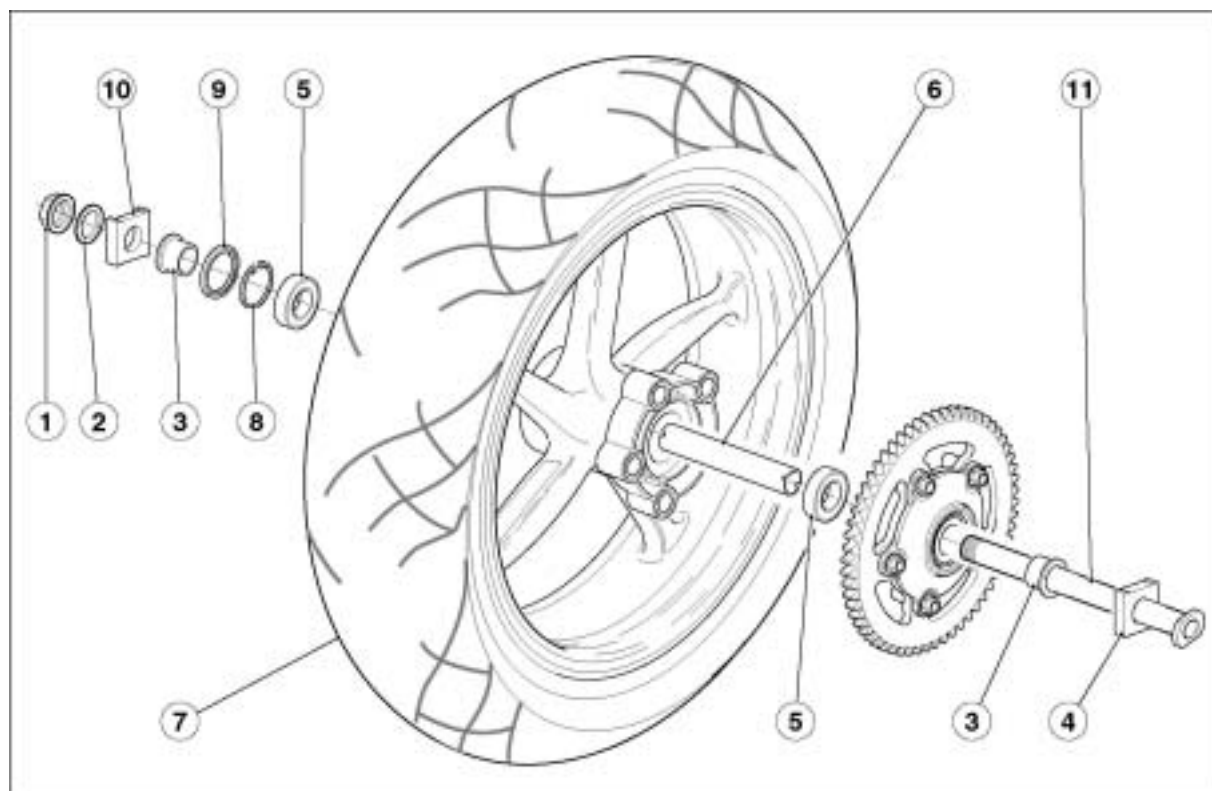

Key:

1. Nut
2. Washer
3. Side spacers
4. Left chain tightener shoe
5. Bearings
6. Central spacer
7. Complete wheel
8. Snap ring
9. Seal
10. Right chain tightener shoe
11. Wheel pin

5.7.2. REMOVING THE REAR WHEEL

- Support the motorcycle on the rear stand
- Slacken off and remove the wheel axle nut
- Retain the thrust washer and left hand chain tightener shoe



- Lightly knock on the wheel axle so that its head protrudes from its seat



- Move the wheel forwards and disengage the chain from the sprocket



- Extract the wheel axle together with the right hand chain guide shoe



- Remove the entire wheel, sliding the disk out from the brake caliper



5.7.3. REMOVING THE FINAL DRIVE UNIT

- Remove the rear wheel.

**CAUTION**

Proceed with care. If the final drive unit (1) is installed on the flexible coupling holder (2), do not overturn or rotate the rear wheel in horizontal position on the rear sprocket side (A), since the final drive unit would come off and fall down, with the risk of damaging the rear sprocket (3).

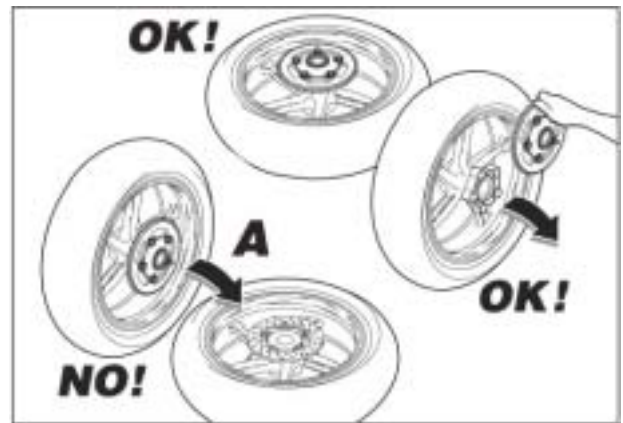

NOTE Do not unscrew the five nuts (4). The whole final drive unit must be withdrawn from the flexible coupling holder.

- Working (B) with both hands on the outer diameter of the sprocket (3), withdraw the final drive unit parallelly to the wheel axis.

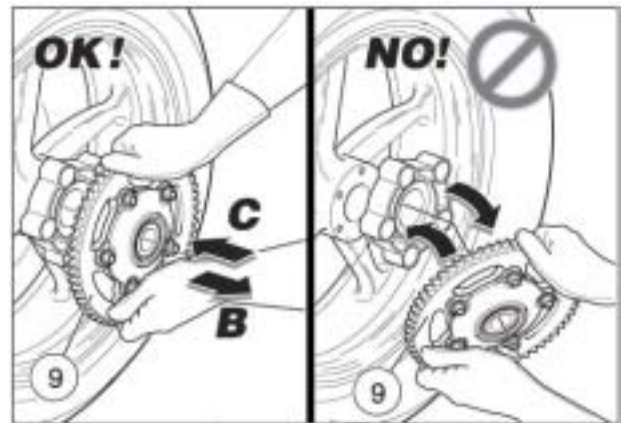
**REASSEMBLY**

NOTE Introduce the final drive unit, parallelly to the wheel axis, inserting the flexible couplings (5) in the corresponding seats on the flexible coupling holder (2).

- Working (C) with both hands on the outer diameter of the sprocket (3), insert the final drive unit in the flexible coupling holder (2).

NOTE Perform the operation described below only if the left (6) and/or the right spacer ring (7) have come off their seats.

- Insert the left (6) and/or the right spacer ring (7) in the respective seats, with the longer diameter towards the outside of the vehicle.

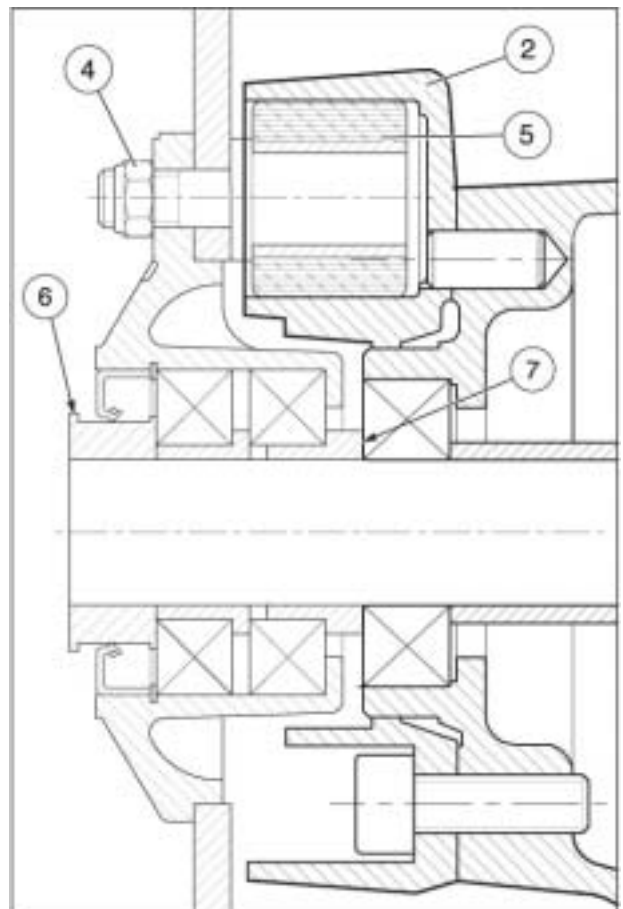

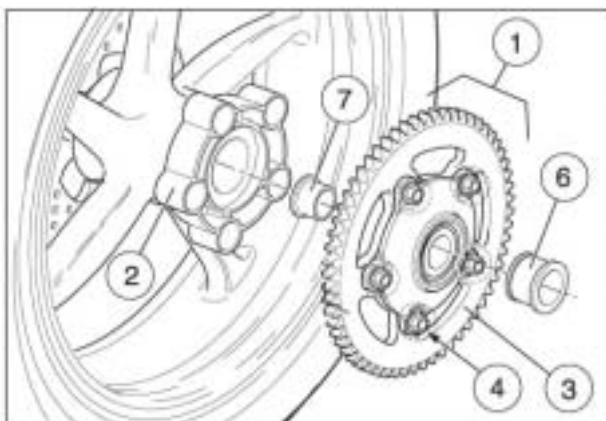

5.7.4. CHECKING THE REAR WHEEL COMPONENTS

**CAUTION**

Make sure that all the components are intact, particularly the following.

REAR WHEEL BEARINGS

Carry out the check with the bearings mounted on the wheel.

CHECKING THE ROTATION

- Manually rotate the inner ring of each single bearing. The rotation must be regular, smooth and noiseless.

If one or both bearings is/are not in compliance with the check parameters:

- Change both wheel bearings.

**WARNING**

Always change both bearings.
Always replace the bearings with bearings of the same type.

CHECKING THE END AND RADIAL PLAY

- Check the radial play and the end play.
End play: a minimum end play is allowed.
Radial play: none.

If one or both bearings is/are not in compliance with the check parameters:

- Change both wheel bearings.

**WARNING**

Always change both bearings.
Always replace the bearings with bearings of the same type.

REAR WHEEL GASKETS

- Make sure the seals are intact; should they prove damaged or feature signs of excessive wear, change them.

**WARNING**

Always change both seals.
Always replace the gaskets with gaskets of the same type.

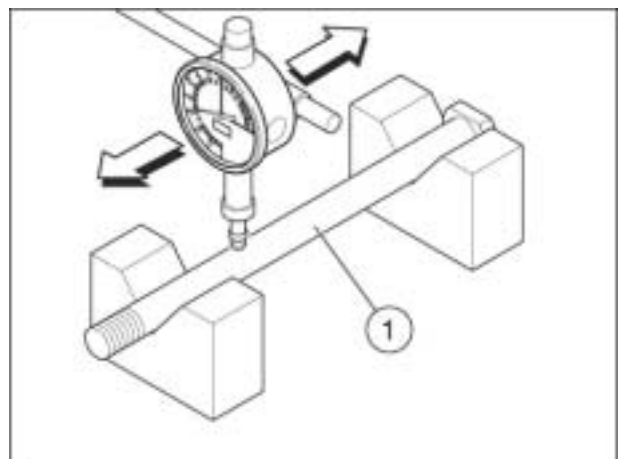

REAR WHEEL PIN

- Check the eccentricity of the pin wheel (1) by means of a comparator. If the eccentricity exceeds the limit value, change the pin wheel (1).

Maximum eccentricity: 0.25 mm.

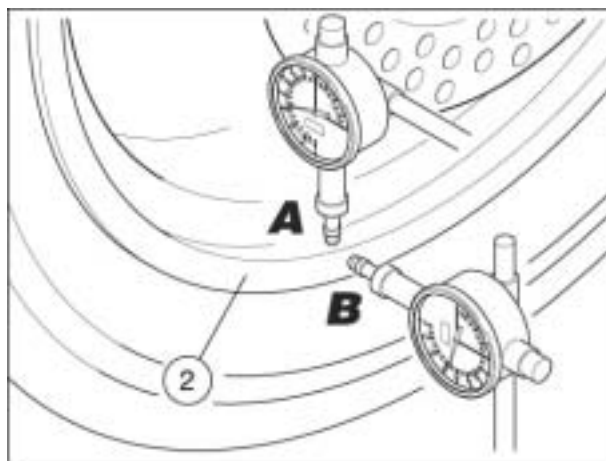
**REAR WHEEL RIM**

- Using a comparator, make sure that the radial (A) and axial (B) eccentricity of the rim (2) do not exceed the limit value.

Excessive eccentricity is usually caused by worn or damaged bearings.

If, after changing the bearings, the value does not fall within the indicated limit, change the rim (2).

Maximum radial and axial eccentricity: 2 mm.

FINAL DRIVE UNIT BEARINGS

- Carry out the check with the bearings mounted on the final drive unit.

CHECKING THE ROTATION

- Remove the left spacer (3).
- Remove the right spacer (4).
- Manually rotate the inner ring of each single bearing. The rotation must be regular, smooth and noiseless.

If one or both bearings is/are not in compliance with the check parameters:

- Change both final drive unit bearings.

**WARNING**

**Always change both bearings.
Always replace the bearings with bearings of the same type.**

CHECKING THE END AND RADIAL PLAY

- Check the radial play and the end play.
End play: a minimum end play is allowed.
Radial play: none.

If one or both bearings is/are not in compliance with the check parameters:

- Change both final drive unit bearings.

**WARNING**

**Always change both bearings.
Always replace the bearings with bearings of the same type.**

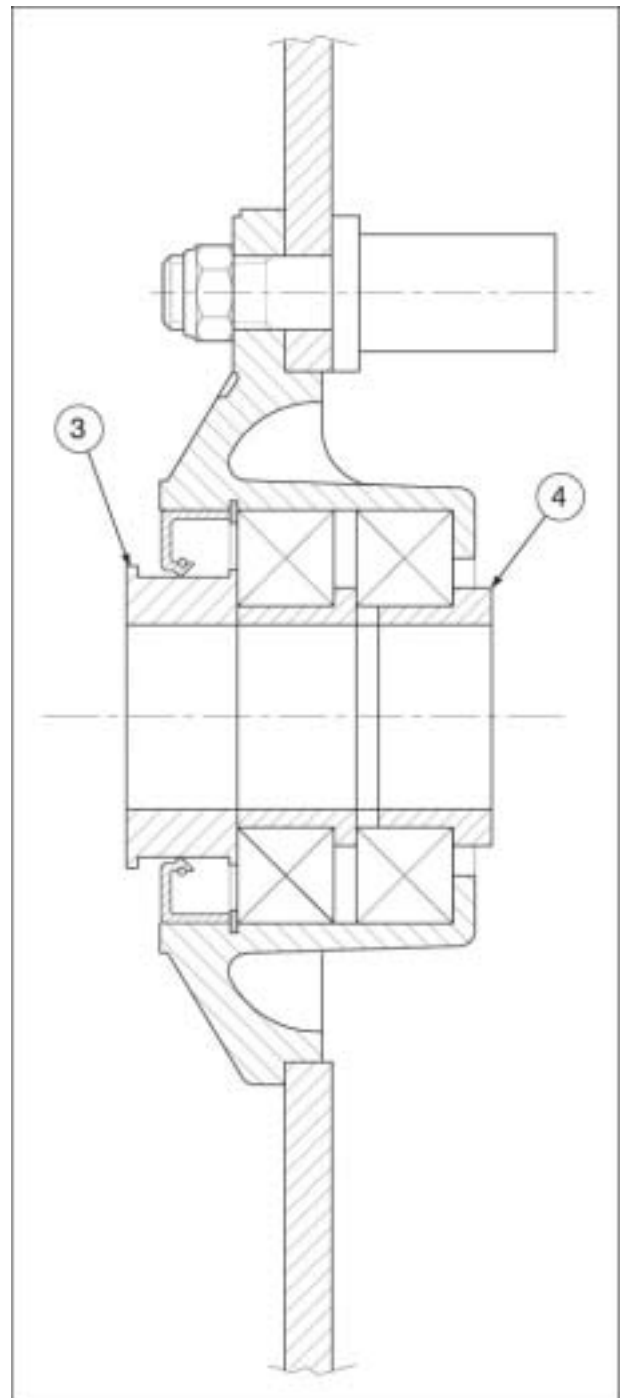

FLEXIBLE COUPLINGS

- Make sure the rubber elements (5) of the flexible couplings are not damaged and/or feature excessive wear.

To carry out the check:

- Fit the whole final drive unit complet (6) on the wheel.
- Manually rotate the crown gear (7) in both directions and check the slack between the flexible coupling rubber elements (5) and the flexible coupling holder (8).

If slack is excessive:

- Change all the flexible coupling rubber elements (5).

**WARNING**

Always replace the flexible couplings with ones of the same type.

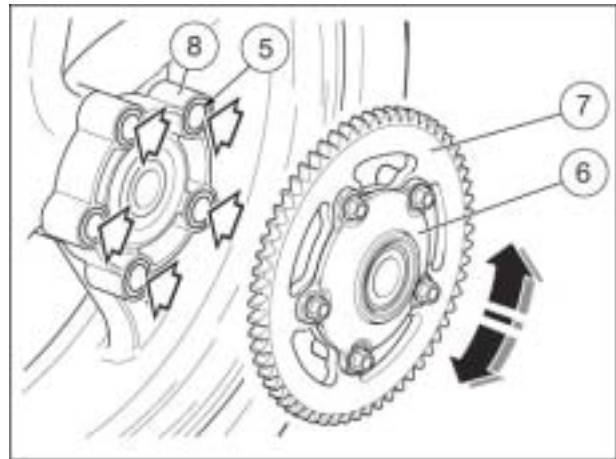
**SPROCKET**

- Check the conditions of the sprocket teeth (7).

If there are signs of excessive wear:

- Change the crown gear, the drive pinion and the drive chain.

**CAUTION**

To avoid the untimely wear of the new components, crown, pinion and drive chain must be replaced all together.



5.7.5. DISASSEMBLING THE REAR WHEEL BEARINGS

- Remove the rear wheel.
- Use a cloth to clean both sides of the hub.

Work on the right side of the wheel:

- Remove the right spacer (1).
- Remove the seal (2).
- Remove the snap ring (3).

NOTE The elastic ring (3) is provided only on the right side of the wheel.

The ends of the spacer (4) are provided with slots (A) to allow the passage of the extractor teeth.

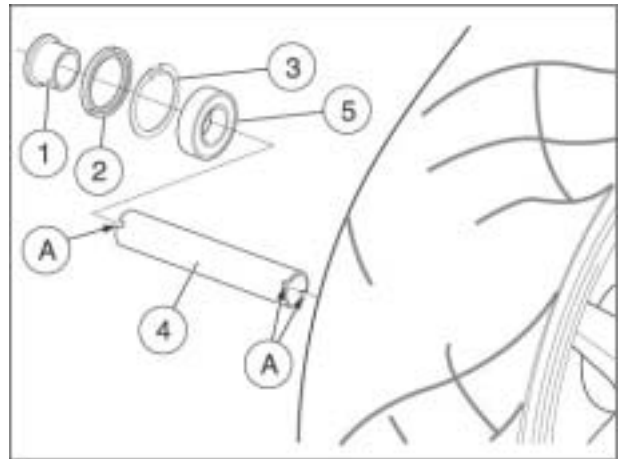

NOTE Have the appropriate special tool **OPT** to hand: - **aprilia** part# 8140180 (bearing extractors).

- Use a special extractor to extract the right bearing (5).
- Retrieve the inner spacer (4).

Work from the left-hand side of the wheel:

NOTE Have the appropriate special tool **OPT** to hand: - **aprilia** part# 8140180 (bearing extractors).

- Use a special extractor to extract the left bearing (6).
- Thoroughly clean the inside of the hub.

NOTE Wash all the components with a clean detergent.

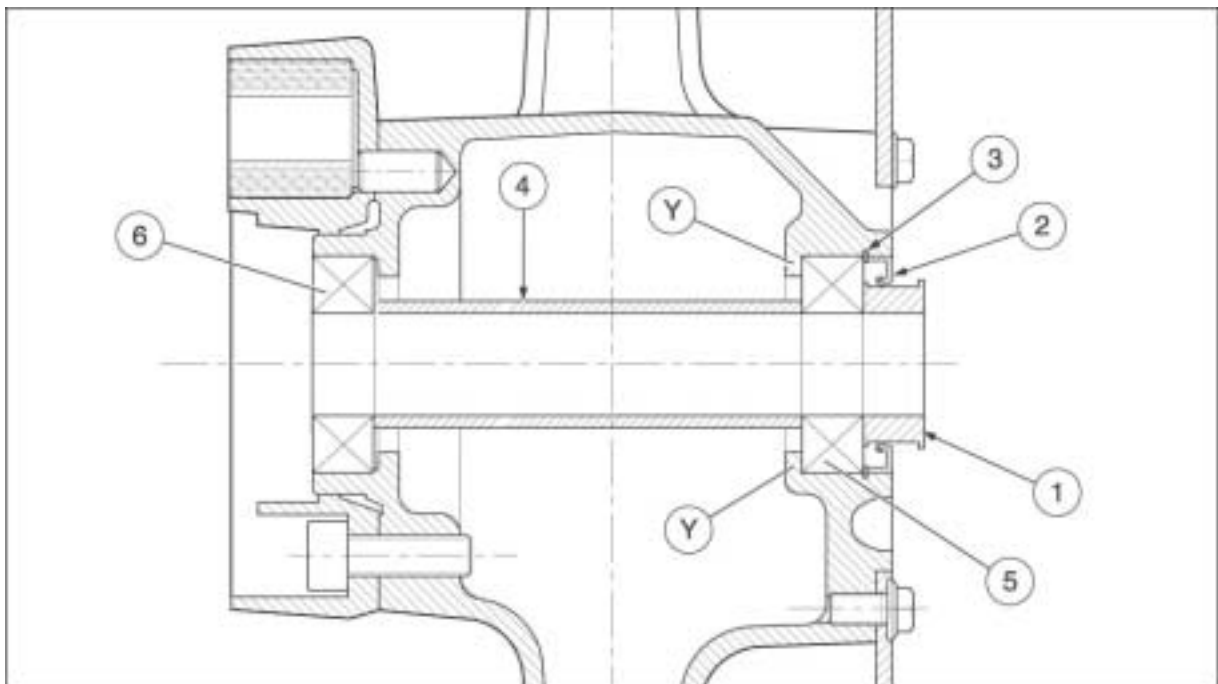
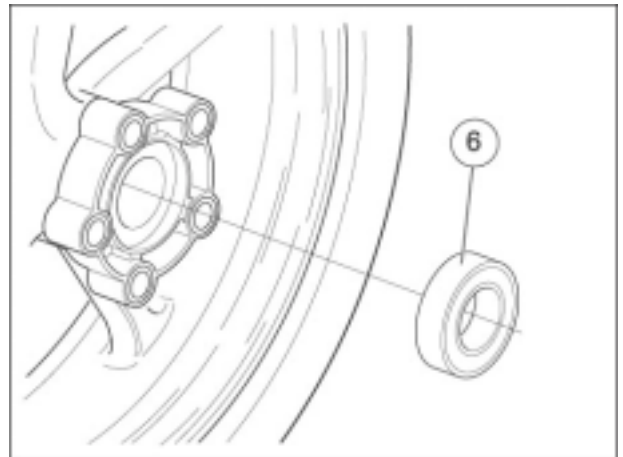

5.7.6. ASSEMBLING THE REAR WHEEL BEARINGS

If provided:

- Remove the rear wheel bearings.

Work on the right side of the wheel:

NOTE Have the appropriate special tool **OPT** to hand:
- **aprilia** part# 8140180 (bearing extractors).

- Using the appropriate pad, insert the right bearing (5) completely.

NOTE The right bearing must be inserted until its contact with the wheel hub shoulder is complete (Y).

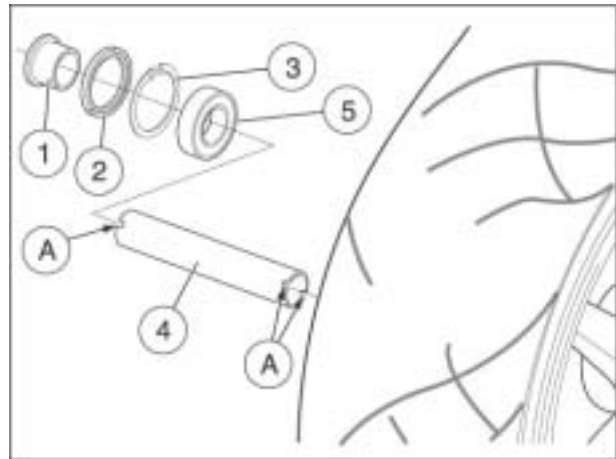

- Insert the elastic ring (3).

NOTE The elastic ring (3) is provided only on the right side of the wheel.

Work from the left-hand side of the wheel:

- Insert the spacer (4).

NOTE Have the appropriate special tool **OPT** to hand:
- **aprilia** part# 8140180 (bearing extractors).

- Use a special pad to insert the left bearing (6).

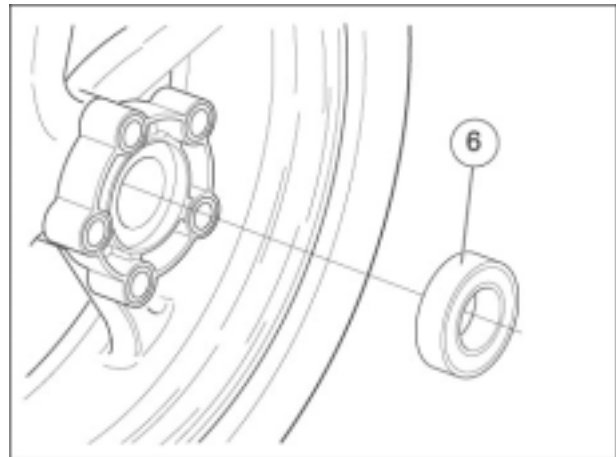

NOTE The complete insertion of the left bearing (6) will bring the following components into contact:

- right bearing (5);
- spacer (4);
- left bearing (6).



CAUTION

After the contact with the right bearing (5) do not push further, in order to avoid forcing the snap ring (3).

NOTE Once the left bearing (6) has been inserted, check the coaxiality of the following components:

- right bearing (5);
- spacer (4);
- left bearing (6).

Work from the right-hand side:

- Install a new seal (2).

Insert the spacer ring (1) with its longer diameter towards the outside of the vehicle.

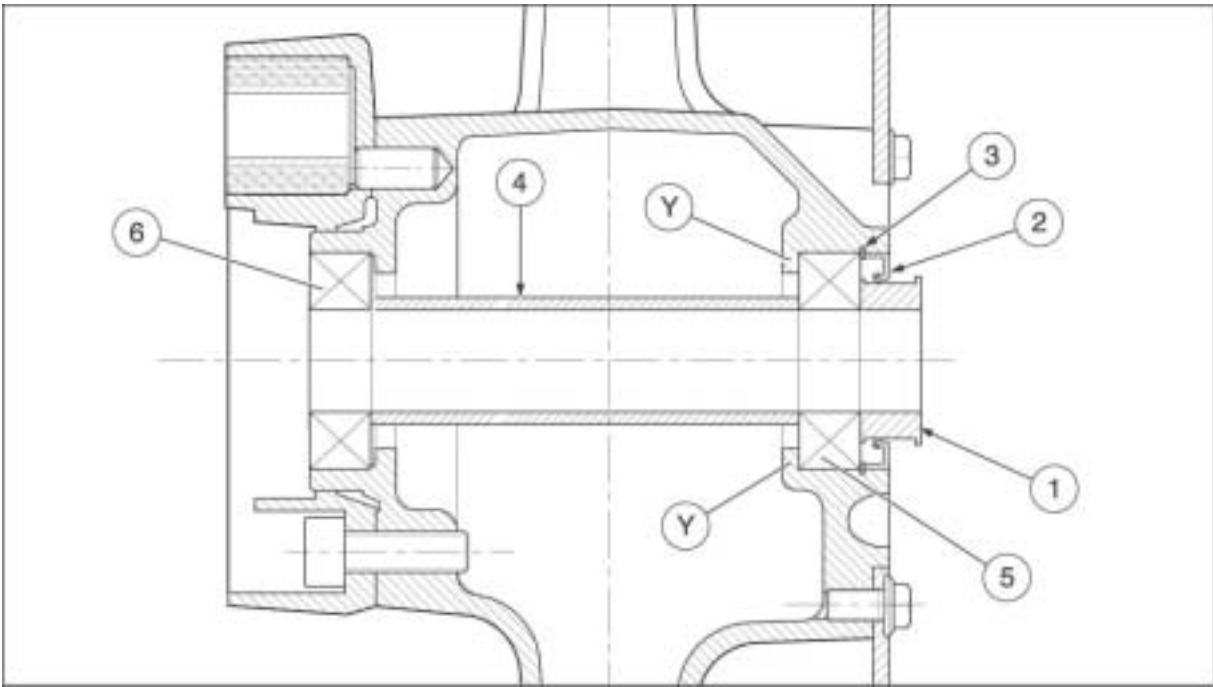

5.7.7. DISASSEMBLING THE FINAL DRIVE UNIT BEARINGS

- Remove the final drive unit.
- Use a cloth to clean both sides of the hub.
- Remove the left spacer (1).
- Remove the seal (2).
- Remove the snap ring (3).

NOTE The elastic ring (3) is provided only on the left side of the final drive unit.

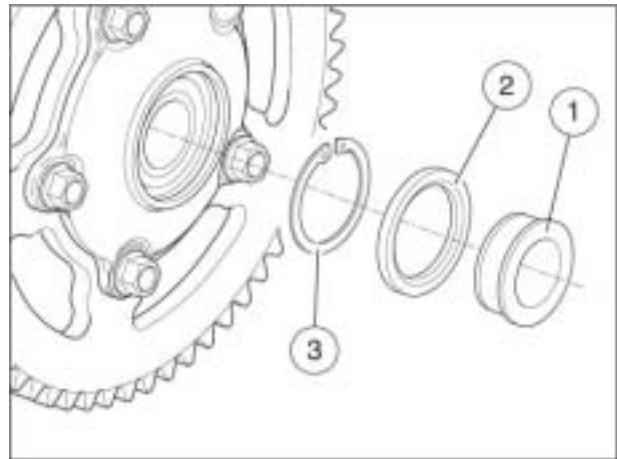

NOTE Have the appropriate special tool **OPT** to hand:
- **aprilia** part# 8140180 (bearing extractors).

- Use a special extractor to extract the left bearing (4).
- Retrieve the inner spacer (5).
- Use a special extractor to extract the right bearing (6).
- Take the right spacer ring (7).
- Thoroughly clean the inside of the hub.

NOTE Wash all the components with a clean detergent.

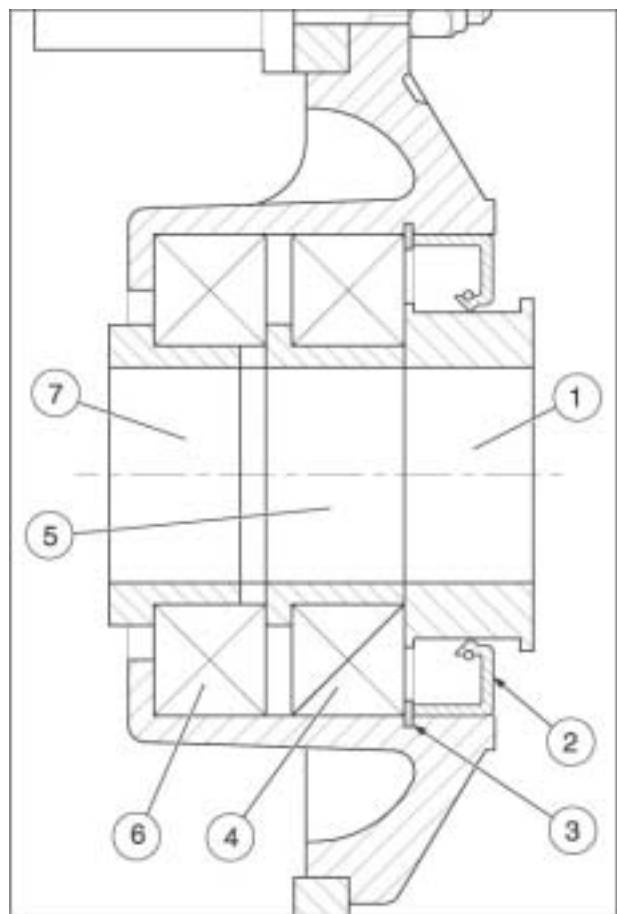
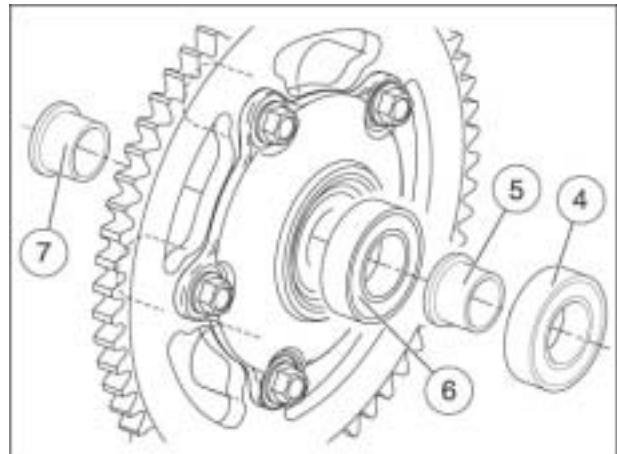

5.7.8. ASSEMBLING THE FINAL DRIVE UNIT BEARINGS

If provided:

- Remove the final drive unit bearings.

Work from the left-hand side:

NOTE Have the appropriate special tool **OPT** to hand:
- **aprilia** part# 8140180 (bearing extractors).

- Using the appropriate pad, insert the right bearing (6) completely.

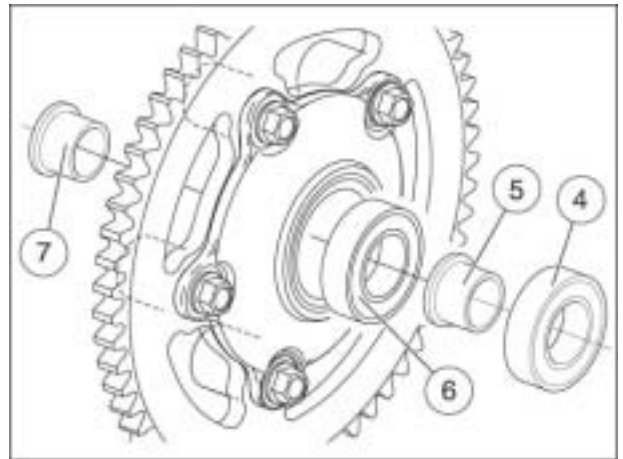

NOTE The right bearing must be inserted until its contact with the wheel hub shoulder is complete (Y).

- Insert the inner spacer (5).
- Use a special pad to insert the left bearing (4).

NOTE The complete insertion of the left bearing (4) will bring the following components into contact:

- right bearing (6);
- inner spacer (5);
- left bearing (4).

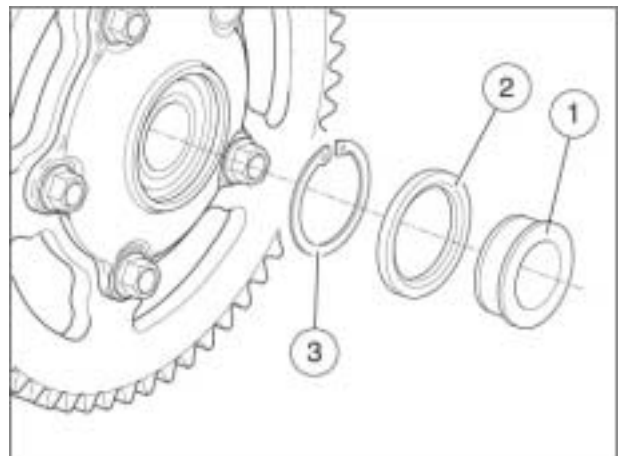

- Insert the elastic ring (3).

NOTE The elastic ring (3) is provided only on the left side of the final drive unit.

- Install a new seal (2).
- Insert the left (1) with the longer diameter towards the outside of the vehicle.

Work from the right-hand side:

- Insert the right spacer (7) with the longer diameter towards the outside of the vehicle.

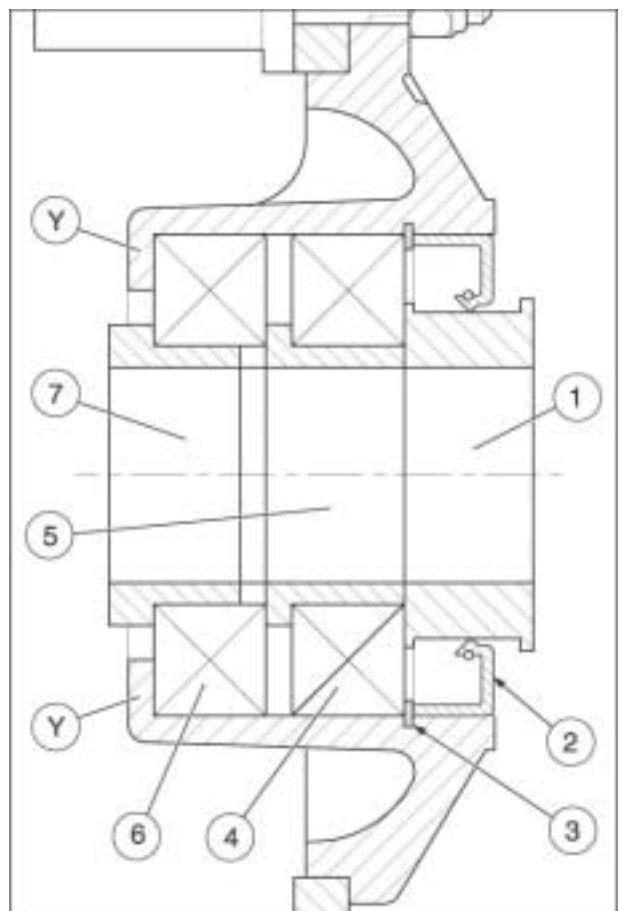

5.7.9. REMOVING THE FLEXIBLE COUPLINGS

- Remove the final drive unit.

NOTE The flexible couplings remain installed on the flexible coupling holder.

- Extract all the flexible coupling rubber elements.



5.7.10. REMOVING THE CROWN GEAR

- Working on the appropriate seat (1) with an hexagon spanner, lock the threaded pin (2), unscrew and remove the self-locking nut (3) and the threaded pin (2).

**CAUTION**

The self-locking nuts (3) must be replaced every three removals of the sprocket. Replace the self-locking nuts (3) with nuts of the same type.

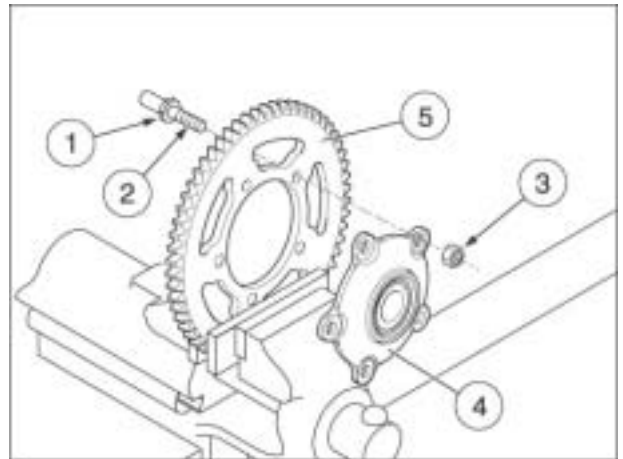

- Remove the crown holder (4).
- Clean the crown gear (5) and the crown holder (4) with clean detergent.

Reassembly:

- Insert the five threaded pins (2) in the sprocket (5).
- Assemble the sprocket holder on the sprocket-threaded pins unit.
- Screw the five self-locking nuts (3) manually.

**CAUTION**

It is forbidden to install the final drive unit (6) on the wheel to tighten the self-locking nuts.

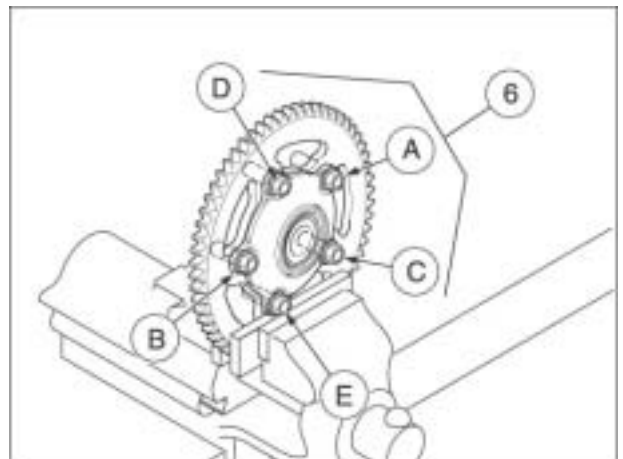
**CAUTION**

To protect the crown gear, install guards (in wood or aluminium) on the vice jaws. Lock only the crown gear in the vice, be careful not to lock any other component of the final drive unit.

- Lock the crown gear in the vice.

NOTE To avoid any deformation and/or incorrect coupling, carry out the tightening as described below:

- Working on the appropriate seat (1) with an hexagon spanner, lock the threaded pin (2) and, applying half the prescribed driving torque, tighten the diametrically opposite elements in the given order: (A) (B) (C) (D) (E).
- Repeat the previous operation by applying the prescribed driving torque.

NOTE In this way the pressure exerted by the fastening elements will be uniformly distributed on the joint surface.

5.7.11. REFITTING THE REAR WHEEL

- Fit the wheel axle together with right hand chain guide shoe to the swing arm.



- Fit the rear wheel and insert the wheel axle into its seat



- Move the wheel forwards to hook the drive chain over the sprocket



- Fit the left hand chain tightener shoe and thrust washer to the axle



- Tighten the nut hand tight
- Check the chain tension



- Tighten the nut to the specified torque



5.7.12. TIGHTENING TORQUES

DESIGNATION	QUANTITY	SCREW / NUT	TORQUE (Nm)	NOTES
REAR WHEEL				
Sprocket / sprocket carrier	5	M10	50	-
Wheel axle nut	1	M25x1,5	120	-

5.8. FRONT BRAKE

5.8.1. CHANGING THE FRONT BRAKE PADS (RSV R)



WARNING

This vehicle is equipped with a double-disc front braking system (right side and left side). Always replace all the pads of both the front brake calipers.

Replacing the pads of one front caliper only may affect the stability and safety of the vehicle, with serious risks for persons, property and the vehicle itself.

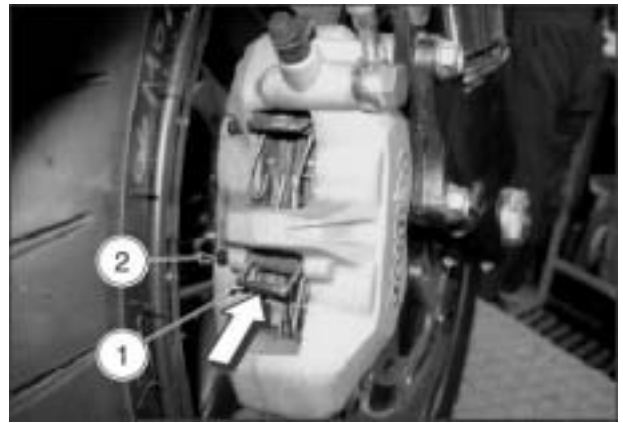

- Position the vehicle on the stand.

NOTE The following procedure refers to a single caliper, though it is applicable to both.

- Press the safety spring (1) and at the same time withdraw the pin (2) from the inside.
- Remove the safety spring (1).

NOTE Using pliers, clamp one pad and then the other, shaking them slightly crosswise so as to eliminate any pressure exerted by the caliper pins, making it easier to extract the pads.

- Extract the two pads (3).

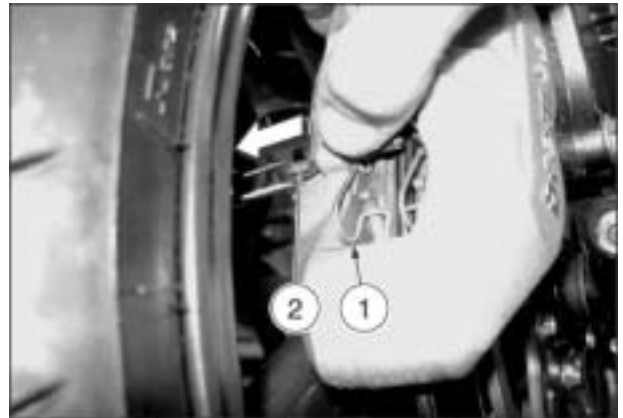

CAUTION

Do not pull the brake lever once the pads have been removed as the caliper pins are liable to come out of their slot, resulting in the spillage of brake fluid.

- Insert two new pads, positioning them correctly.



CAUTION

Always change both pads and make sure that they are correctly positioned inside the caliper.



- Refit the safety spring (1).
- Press the safety spring (1) and at the same time insert the pin (2) from the inside.
- Release the safety spring (1).



WARNING

When released, the safety spring (1) must lock the pin (2) and fit in the appropriate seats (A). If the spring is positioned correctly, it will not be possible to withdraw the pin (2); carry out a check.

- Check the front brake fluid level.

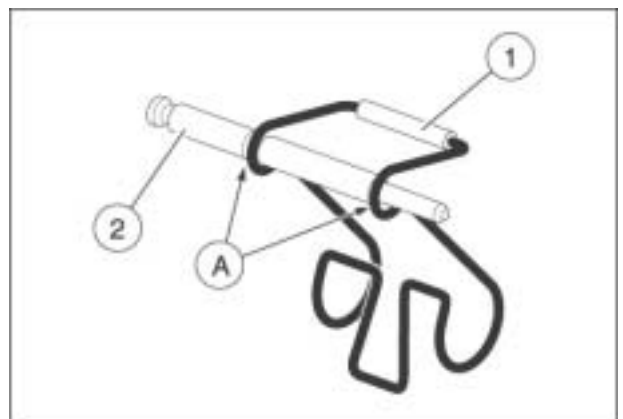

5.8.2. CHANGING THE FRONT BRAKE PADS (RSV FACT)

TORQUE WRENCH SETTINGS

Brake caliper bolts (1) 50 Nm (5.0 kgm)



WARNING

This vehicle is equipped with a twin-disk front brake (one disk on either side of the wheel). Always change all brake pads of both front brake calipers as a set.

Changing the brake pads of one front brake caliper only will affect the stability and safety of the vehicle, putting the safety of persons or property at risk or leading to vehicle damage.

NOTE The following procedure applies to both brake calipers.

- Release and remove the two caliper mounting bolts (1).
- Withdraw the front brake caliper from the disk.
- Press the retaining clip (2) and withdraw the pin (3) from the inside.
- Remove the retaining clip (2).
- Extract both pads (4).



WARNING

Do not operate the brake lever with the brake pads removed, or the brake caliper pistons might fall out leading to loss of brake fluid.

- Fit new brake pads and ensure they become properly seated in the caliper.

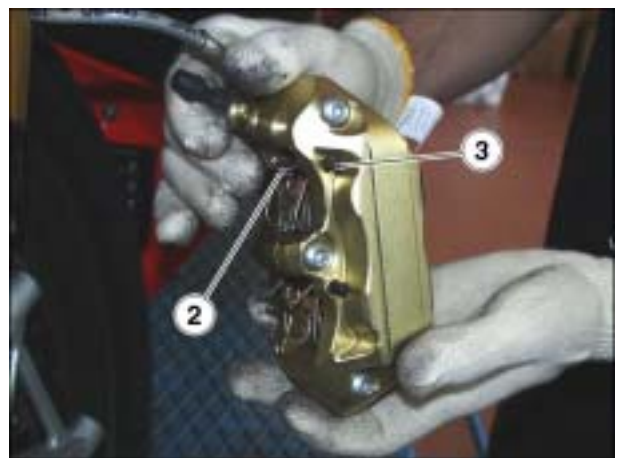

**WARNING**

The four brake pads must always be replaced together. Ensure they become properly seated in the brake caliper.

- Position the retaining clip (2).
- Press the retaining clip (2) and insert the pin (3) from the inside.
- Release the retaining clip (2) and ensure it becomes securely engaged with the pin (3).

**DANGER**

When released, the retaining clip (2) should become correctly located into its seats to lock the pin (3) in place.

When the clip is positioned correctly, the pin (3) will not come off. Try to extract the pin to ensure clip and pin are securely in place.

- Position the front brake caliper to the brake disk.
- Tighten the two bolts (1) fully until finger tight.
- Operate the front brake lever. This will help the brake caliper become properly seated.
- Keep the brake squeezed in and tighten the two bolts (1).
- Check front brake fluid level.

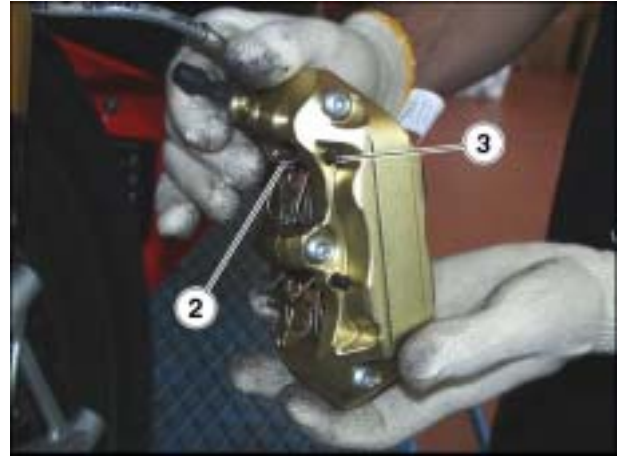

5.8.3. CHECKING THE FRONT BRAKE DISCS

Brake discs:

NOTE These operations must be performed with the brakes discs installed on the wheel; they refer to a single disc, though they are applicable to both.

- Check the wear on the disc by measuring the minimum thickness in several places by means of a micrometer. If the minimum thickness is below the minimum value, even in a single point, change the disc.

Brake disc min. thickness: 4 mm.

- Using a comparator, make sure that the maximum wobbling of the disc does not exceed the limit value, otherwise change it.

Brake disc max. wobbling: 0.3 mm

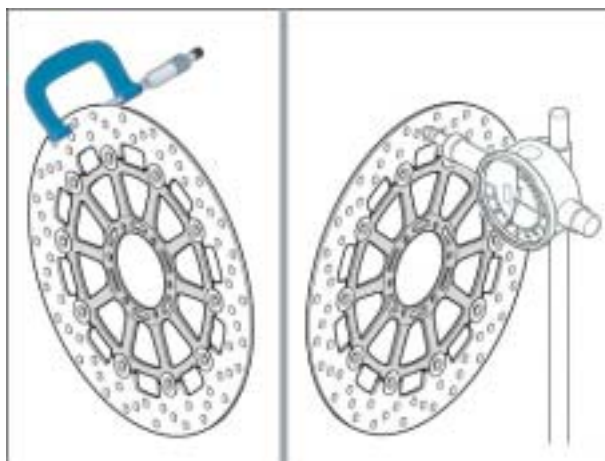

5.8.4. REMOVING THE FRONT BRAKE DISCS

- Remove the front wheel.

NOTE The following procedure refers to a single disc, though it is applicable to both.

To unscrew the screws (1), it is advisable to use a percussion screwdriver, thanks to which it will be possible to detach the screws from the LOCTITE® 243.

- Unscrew and remove the six brake disc screws (1).

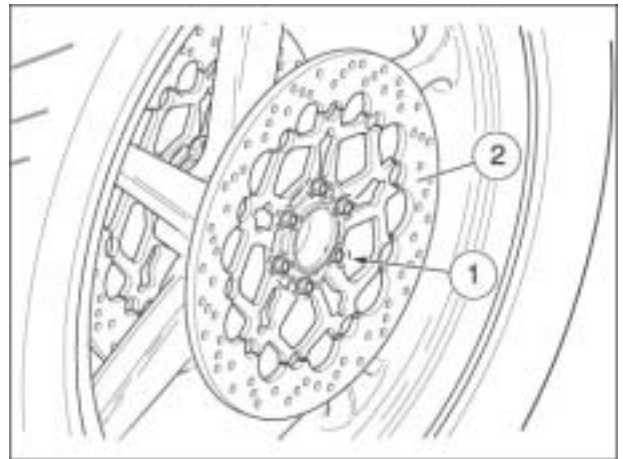
**CAUTION**

When reassembling, apply LOCTITE® 243 on the thread of the brake disc screws (1).

NOTE When reassembling, screw all the screws (1) on manually and tighten them in a crisscross pattern in the following order: A-B-C-D-E-F.

- Remove the brake disc (2).

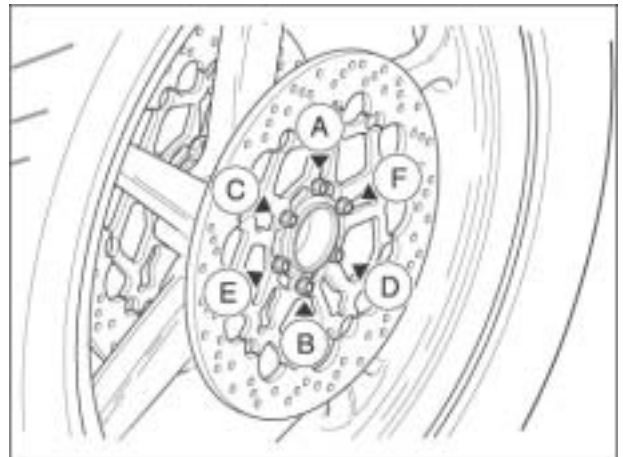

5.8.5. BLEEDING THE BRAKE CIRCUIT

- Connect the hose to the brake pump bleed nipple.
- Operate the brake lever and open the pump bleed nipple slightly to allow the air to escape.
- Close the nipple before reaching the lever's full stroke and repeat the operation until no more air issues from the nipple.
- Connect the tubes to the brake calliper bleed nipples.
- Operate the brake lever and open the calliper bleed nipple slightly to allow the air to escape.
- Close the nipple before reaching the lever's full stroke and repeat the operation until no more air issues from the nipple.
- To be quite sure of the result, repeat the pump bleed operation.



5.9. REAR BRAKE

5.9.1. CHANGING THE REAR BRAKE PADS

- Position the vehicle on the stand.
- Remove the rear brake caliper.



CAUTION

Do not pull the brake lever once the pads have been removed as the brake caliper pins are liable to come out of their slot, resulting in the spillage of brake fluid

- Remove the stop ring (1).

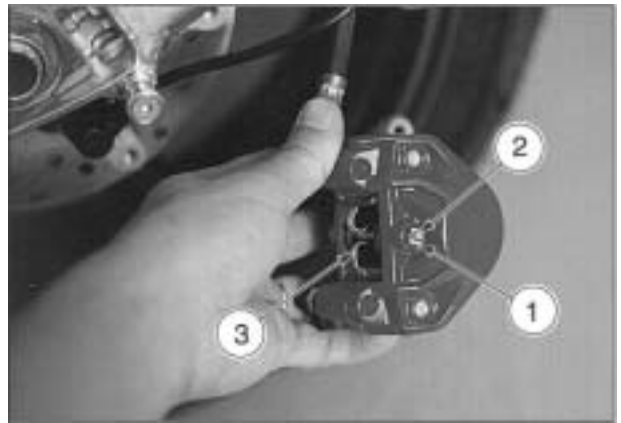

CAUTION

Before sliding out the pin (2), take note of the positioning of the safety spring (3); when re-assembling, it must be refitted in the same way.

- Pull out the pin (2) and retrieve the safety spring (3).
- Extract the two pads (4).

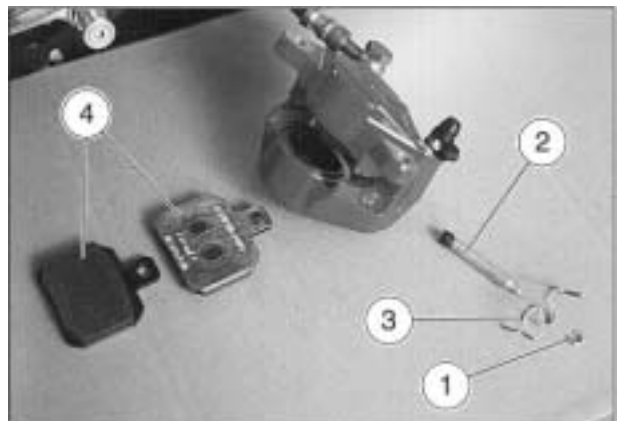

CAUTION

Do not pull the brake lever once the pads have been removed as the caliper pins are liable to come out of their slot, resulting in the spillage of brake fluid.

- Insert two new pads, positioning them so that the holes are lined up with those in the caliper.



CAUTION

Always change both pads and make sure that they are correctly positioned inside the caliper.

- Refit the safety spring (3).
- Keeping the safety spring (3) pressed in the middle, insert the pin (2) so that it passes over it.
- Refit the stop ring (1).
- Check the brake fluid level.

5.9.2. CHECKING THE REAR BRAKE DISC

NOTE These operations must be performed with the brake disc installed on the wheel.

- Check the wear on the disc by measuring the minimum thickness in several places by means of a micrometer. If, even in one point of the disc only, the minimum thickness is below the minimum value.

Brake disc min. thickness: 4 mm.

- Using a comparator, make sure that the maximum wobbling of the disc does not exceed the limit value, otherwise change it.

Brake disc max. wobbling: 0.3 mm.

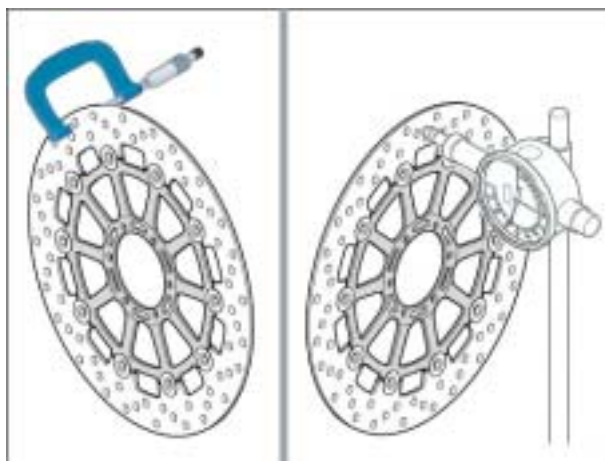

5.9.3. REMOVING THE REAR BRAKE DISC

- Remove the rear wheel.

NOTE To unscrew the screws (1), it is advisable to use a percussion screwdriver, thanks to which it will be possible to detach the screws from the LOCTITE® 243.

- Unscrew and remove the five brake disc screws (1).

**CAUTION**

When reassembling, apply LOCTITE® 243 on the thread of the brake disc screws (1).



NOTE When reassembling, screw all the screws on manually and tighten them in a crisscross pattern in the following order: A-B-C-D-E.

- Remove the brake disc (2).

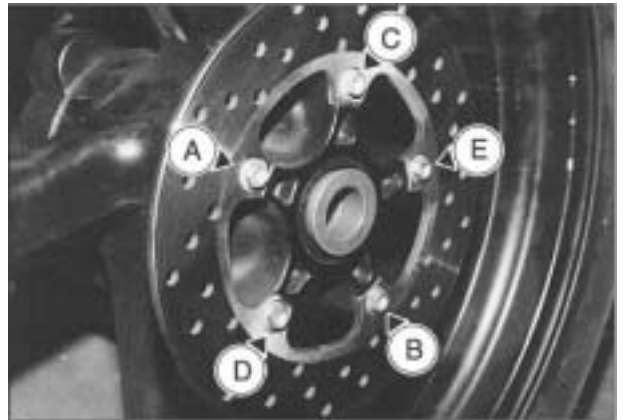

5.10. CLUTCH

5.10.1. BLEEDING THE CLUTCH CIRCUIT

- Connect the hose to the clutch pump bleed nipple.
- Operate the clutch lever and open the pump bleed nipple slightly to allow the air to escape.
- Close the nipple before reaching the lever's full stroke and repeat the operation until no more air issues from the nipple.



- Connect the hose to the clutch control cylinder bleed nipple.



- Operate the clutch lever and open the cylinder bleed nipple slightly to allow the air to escape.
- Close the nipple before reaching the lever's full stroke and repeat the operation until no more air issues from the nipple.
- To be quite sure of the result, repeat the pump bleed operation.



5.11. DRIVE CHAIN

5.11.1. DRIVE CHAIN

The vehicle is fitted with an endless chain that has no master link.

NOTE Halve maintenance intervals if the vehicle is used in rainy or dusty conditions, on rough roads or for racing.

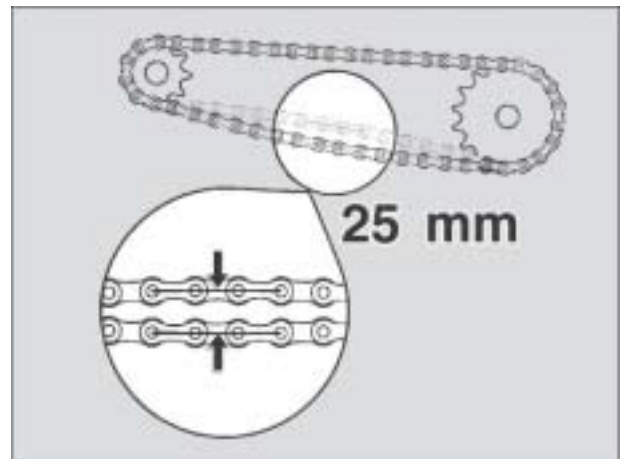

CHAIN SLACK INSPECTION

To check chain slack:

- Stop the engine.
- Place the vehicle on the stand.
- Put the gearbox in neutral.
- Check chain slack by measuring the vertical movement of the chain lower section, midway between the sprockets. Movement should be approximately **25 mm**.
- Move the motorcycle forward to check slack at various sections of the chain. Slack should be the same throughout one full turn of the wheel.

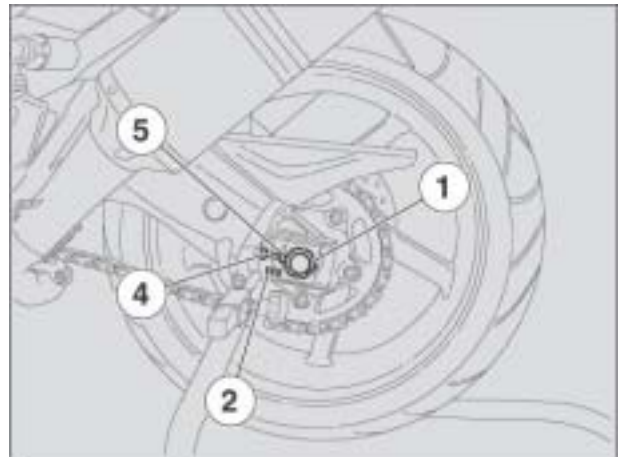

CHAIN SLACK ADJUSTMENT

NOTE To adjust chain slack, you will need the rear wheel stand **OPT**. Make sure to have it ready at hand.

If the chain needs adjusting after the inspection, proceed as follows:

- Place the vehicle on the rear wheel stand.
- Loosen the nut (1) completely.

NOTE Wheel centring is aided by fixed reference marks (2-3) located inside the seats of the chain sliders/tensioners fitted to the swinging arm before the wheel spindle.

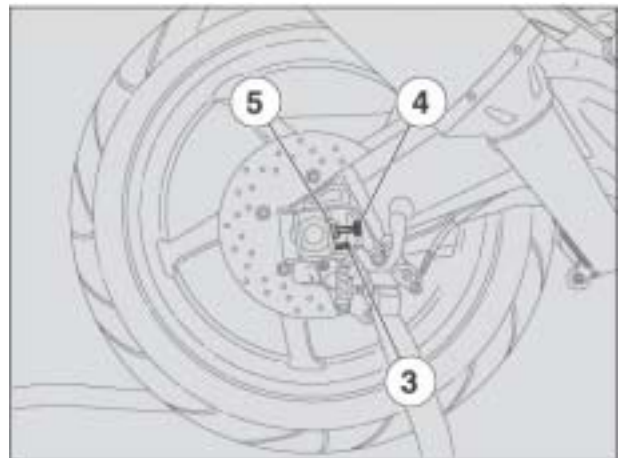

- Loosen the two lock nuts (4).
- Work the adjusters (5) and adjust chain slack, making sure to use the same reference mark settings (2-3) on both sides of the vehicle.
- Tighten the two lock nuts (4).
- Tighten the nut (1).
- Check chain slack.

CHECKING CHAIN AND SPROCKETS FOR WEAR

Check the following parts every 10000 km (6250 mi).

Visually inspect chain, front and rear sprockets looking for:

- damaged chain rollers;
- loose chain link pins;
- dry, rusty, warped or seized links;
- exceeding wear;
- missing O-rings;
- exceedingly worn or damaged sprocket teeth.

**CAUTION**

If chain rollers are damaged, chain link pins are loose and/or any O-rings are missing or deteriorated, renew the drive chain and the front and rear sprockets as a set.

Lubricate the chain frequently, especially if you find any dry or rusty parts.

Warped or seized links must be lubricated and repaired.

CLEANING AND LUBRICATION**CAUTION**

The drive chain links are fitted with O-rings that retain the grease inside. Use the utmost care when adjusting, lubricating, washing or replacing the chain.

Never wash the drive chain using steam cleaners, high-pressure water nozzles or highly flammable solvents.

- Wash the drive chain with fuel oil or kerosene. If the chain tends to become rusty quickly, service more frequently.

Lubricate the chain every 1000 km (625 mi) and whenever it seems appropriate.

- After washing the chain, let it dry, then spray with aerosol lubricant for O-ring chains.

5.11.2. INSPECTING THE DRIVING CHAIN SHOE

- Position the vehicle on the stand.
- Make sure the shoe (1) is not worn or damaged; if so, replace with a new one.
- Check the wear of the chain plastic guide (2).

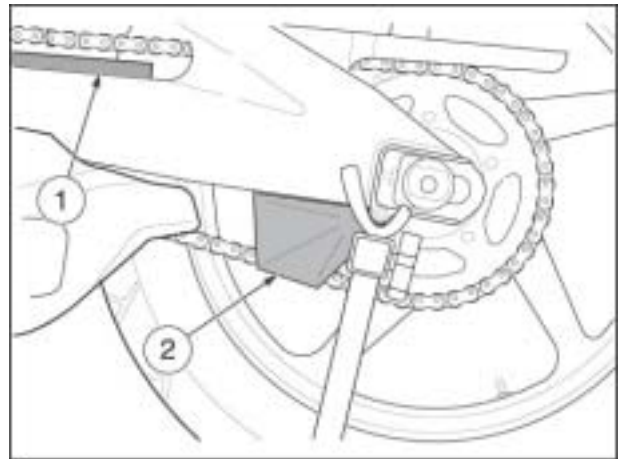

5.11.3. REMOVING THE CHAIN SHOE

- Position the vehicle on its rear stand (**OPT**).
- Release and remove the three screws.
- Remove the pinion cover.
- Slacken off the chain tension.



- Release and remove the pinion screw and collect the washers.

IMPORTANT When refitting, apply **LOCTITE® Anti-Seize** to the inner pinion tooting and **LOCTITE® 243** to the screw threads.



- Undo and remove the two left rider foot peg cover screws.



- Undo and remove the upper chain shoe screw and collect its washer.



- Undo and remove the lower chain shoe screw and collect its washer.



- Pull the lower part of the chain shoe out from the front.



- Remove the lower chain shoe from the rear.



5.11.4. LOWER CHAIN SHOE

IMPORTANT The shoe must be disassembled to check its wear.

- Release and remove the two screws.
- Remove the lower chain shoe.

**CHECKING WEAR**

Check the wear of the chain shoe.

Minimum thickness : 2 mm (0.079 in).

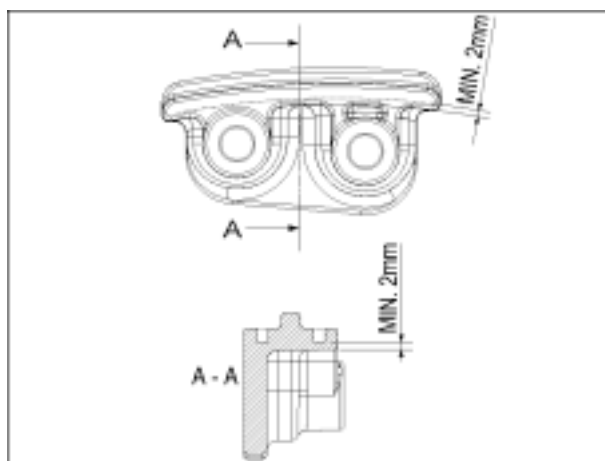

COOLING SYSTEM

6

SUMMARY

6.1. COOLING SYSTEM 3
6.1.1. DIAGRAM 3
6.1.2. FILLING THE COOLING SYSTEM 4

6.1. COOLING SYSTEM

6.1.1. DIAGRAM

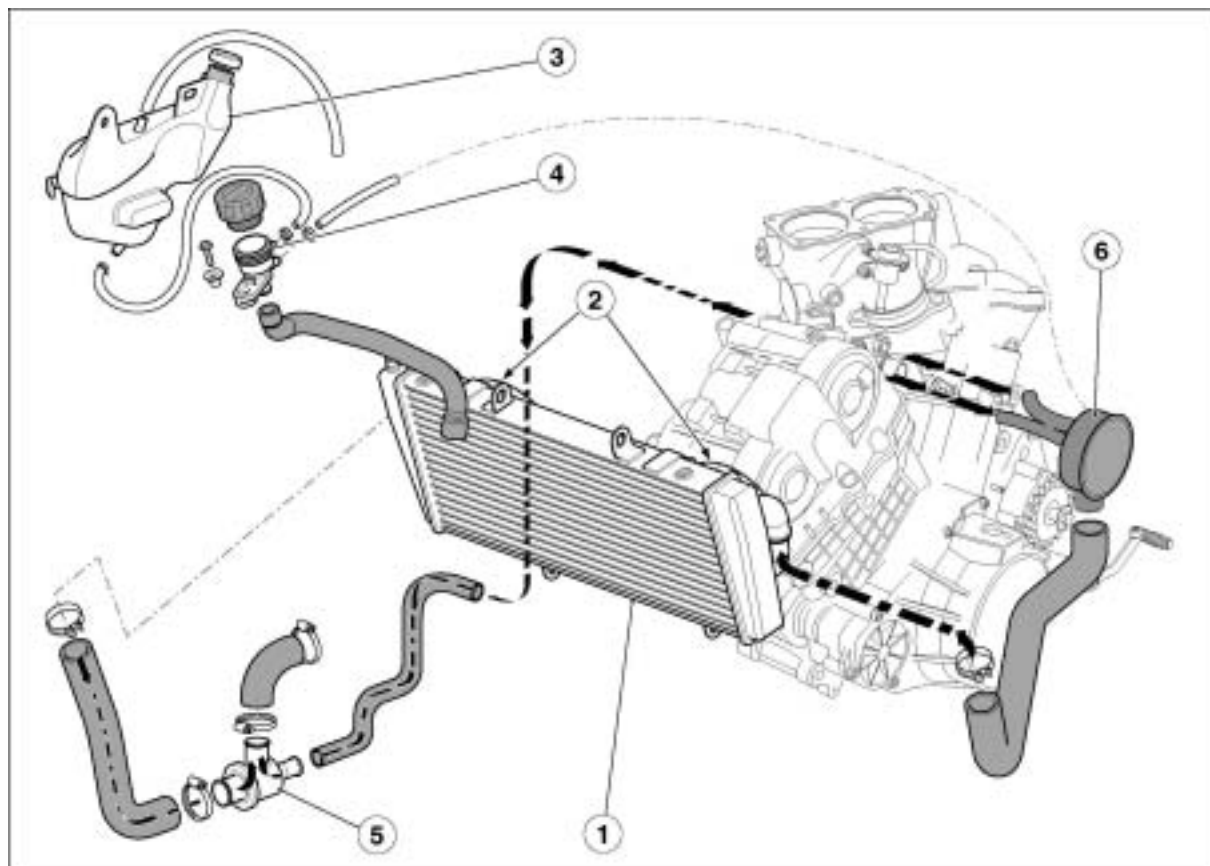

Key:

1. Radiator
2. Fans
3. Expansion reservoir
4. Filler cap
5. Three-way thermostatic valve
6. Three-way manifold

6.1.2. FILLING THE COOLING SYSTEM

- Filling the cooling system requires around 2.2 litres of coolant.
- Place the vehicle on its rear stand.**OPT.**
- Undo the radiator bleed screw.



- Unscrew the filler cap.
- Pour around 2 litres of coolant into the radiator via the filler cap.



- When the coolant starts to issue from the radiator bleed screw, tighten the screw down to its prescribed torque.
- Complete filling the circuit up to the upper rim of the filler cap.



- Unscrew the expansion reservoir cap and pour in the remaining 0.2 litres of coolant until it reaches a level between the **MIN** and **MAX** marks.



RSV 1000 R - RSV 1000 R FACTORY

- Tighten down the filler cap and the expansion reservoir cap.
 - If fluid does not issue from the radiator bleed screw, before the circuit is completely filled (around 2 litres) use the expansion reservoir level as a reference.
 - Run the engine for about 30 seconds with the filler cap open.
 - Switch off the engine and pour coolant into the filler cap.
 - Complete filling the circuit up to the upper rim of the filler cap.
-
- Run the engine up to its normal running temperature (the fans must cut in at least twice), switch it off and wait for it to cool down (around 12 hours).
 - Check that the coolant level is still between the **MIN** and **MAX** marks.



ELECTRICAL SYSTEM

SUMMARY

7.1. ELECTRICAL SYSTEM..... 3

7.1.1. COMPONENT LOCATION..... 3

7.1.2. ELECTRICAL EQUIPMENT CHECK TABLE 5

7.1.3. CAN LINE..... 14

7.1.4. IMMOBILIZER..... 16

7.1.5. WIRING DIAGRAM 18

7.1. ELECTRICAL SYSTEM

7.1.1. COMPONENT LOCATION

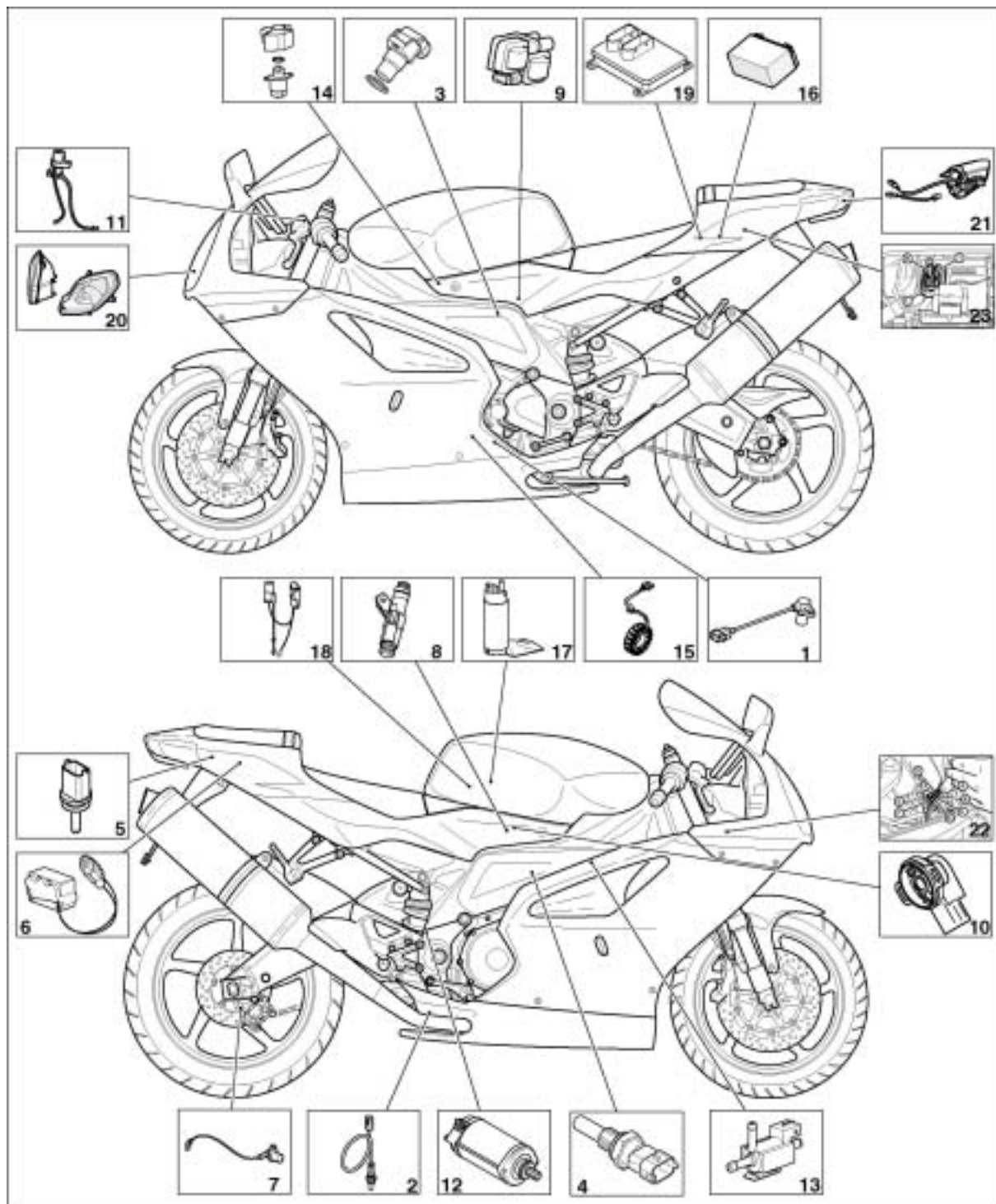

Key:

1. Engine speed sensor
2. Sensor
3. Camshaft sensor
4. Coolant temperature sensor
5. Intake air temperature sensor
6. Fall sensor
7. Vehicle speed sensor
8. Injector
9. Ignition coil
10. Throttle potentiometer (TPS)
11. Immobilizer antenna
12. Starter motor
13. Intake flap
14. Stepper
15. Generator
16. Recharge voltage
17. Fuel pump
18. Fuel reserve sensor
19. ECU
20. Head lamp
21. Tail light
22. Secondary fuses
23. Main fuses

7.1.2. ELECTRICAL EQUIPMENT CHECK TABLE

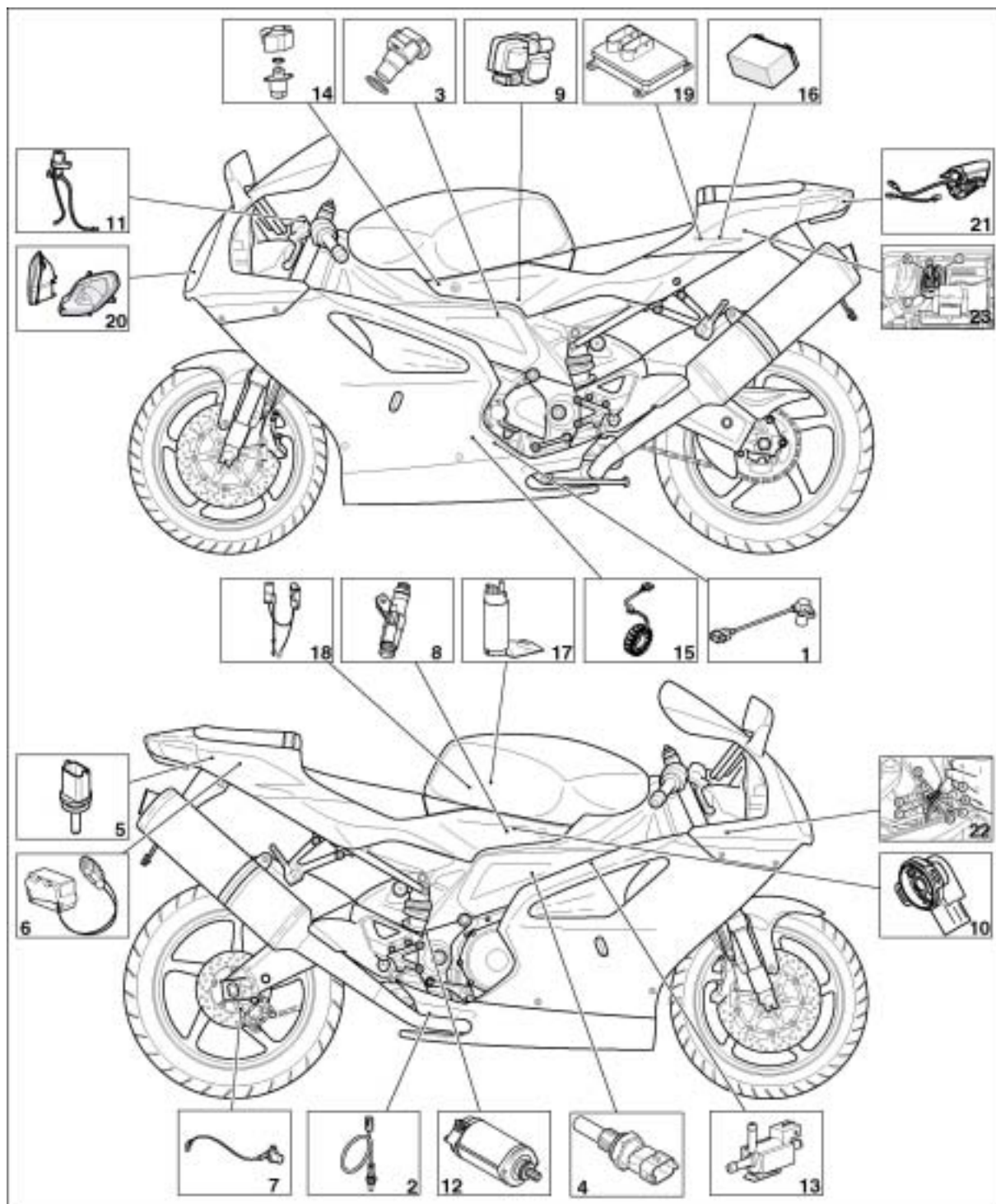

1 ENGINE SPEED SENSOR

inductive sensor

winding resistance 1 K Ω (across pins 1 and 2)

output voltage 3 V AC (under load)

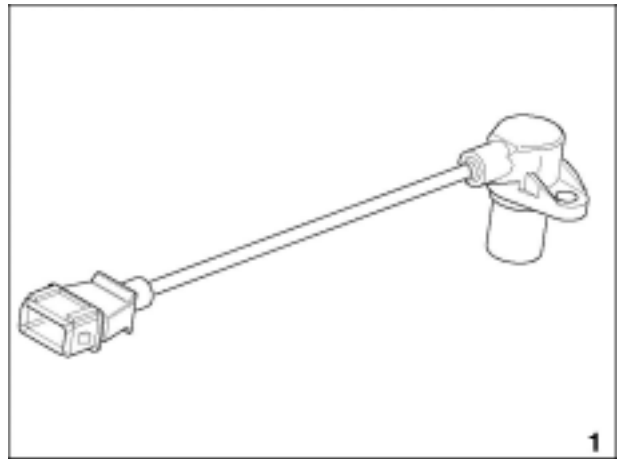
**2 LAMBDA SENSOR**

oxygen sensor with heater

sensor voltage 0 to 0.9 V (across pins 3 and 4)

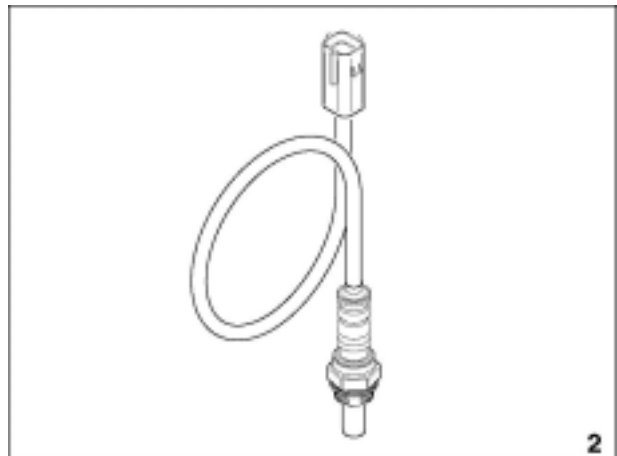
heater resistance 12.5 Ω (across pins 1 and 2 at 20°C – 68°F)**3 CAMSHAFT SENSOR**

hall effect sensor

power 12 V

square wave output, 1 pulse every 2 engine revolutions

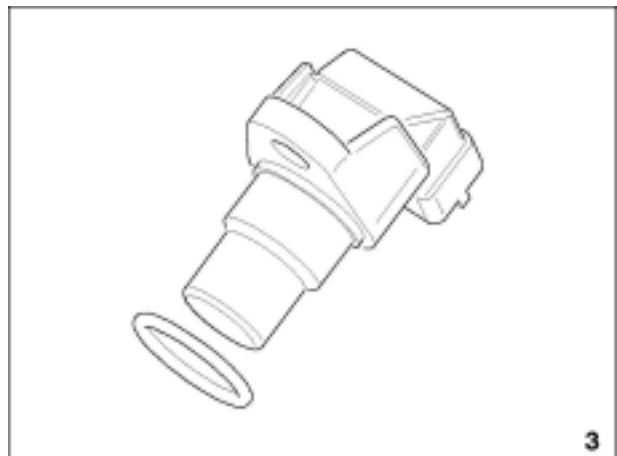
**4 COOLANT TEMPERATURE SENSOR**

NTC sensor

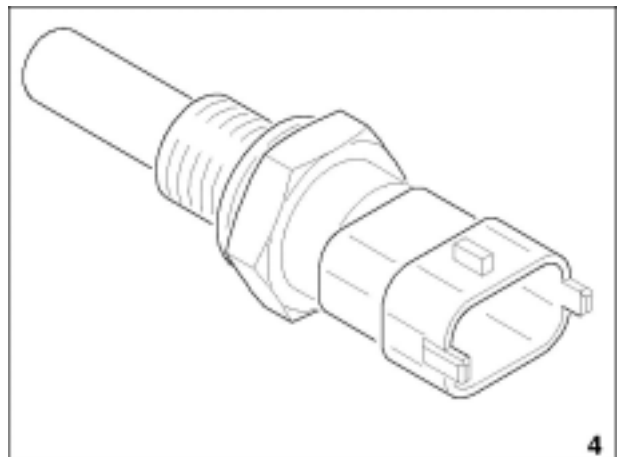
resistance 2.5 K Ω (at 20°C – 68°F)resistance 220 Ω (at 100°C – 212°F)

5 INTAKE AIR TEMPERATURE SENSOR

NTC sensor
resistance 1.9 K Ω (at 20°C – 68°F)

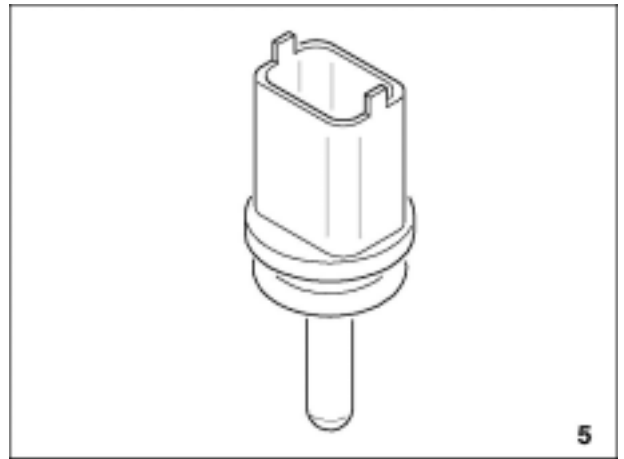
**6 FALL SENSOR**

resistance 62 K Ω with sensor at installation position
resistance 0 Ω when rotated 90° relative to installation position.

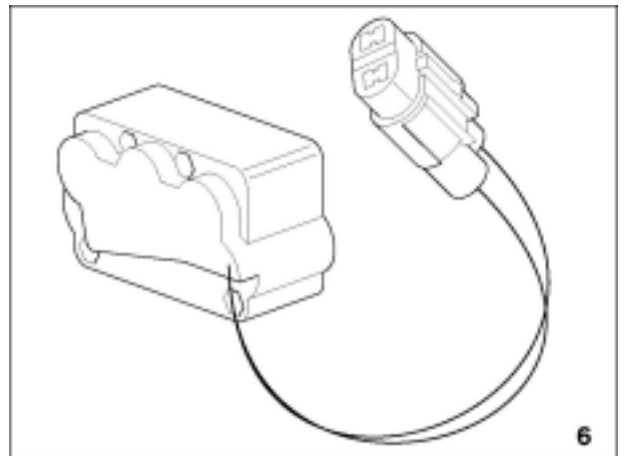
**7 VEHICLE SPEED SENSOR**

hall effect sensor with square wave output, 5 pulses every revolution
power 11-12V (across pins 1 and 3)
sensor signal is low when the sensor is facing the screw head (across pins 2 and 3)

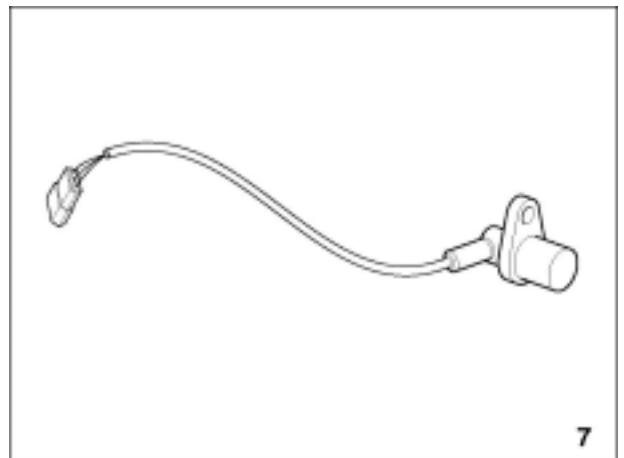
**8 INJECTOR**

resistance 15 Ω

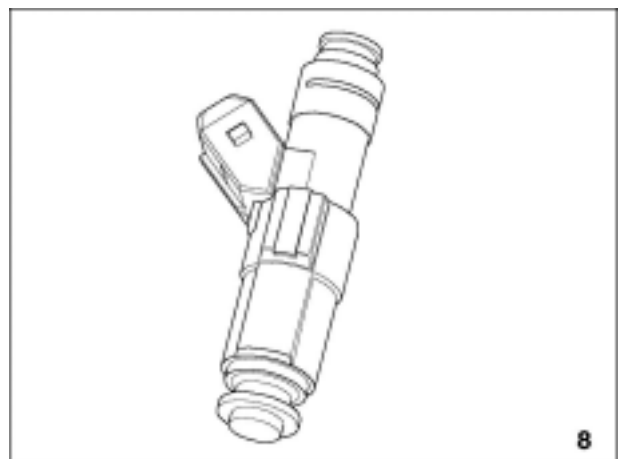

- 9 IGNITION COIL**
primary resistance 0.4-0.5 Ω

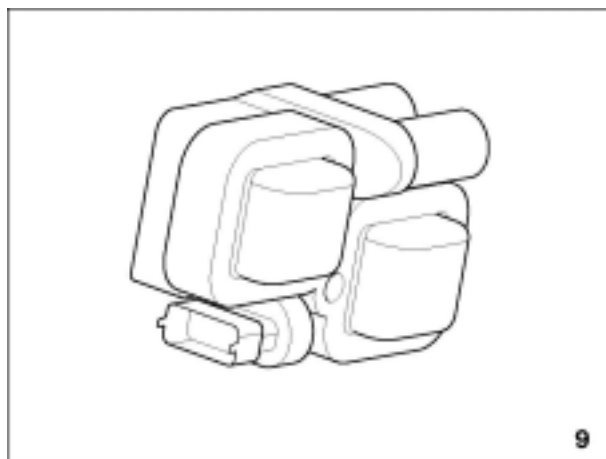

- 10 THROTTLE POTENTIOMETER (TPS)**
resistance $4.1 \pm 1.23 \Omega$ (across pins 1 and 4)
output voltage 0.5-4 V (varies according to throttle position, across pins 2 and 4)

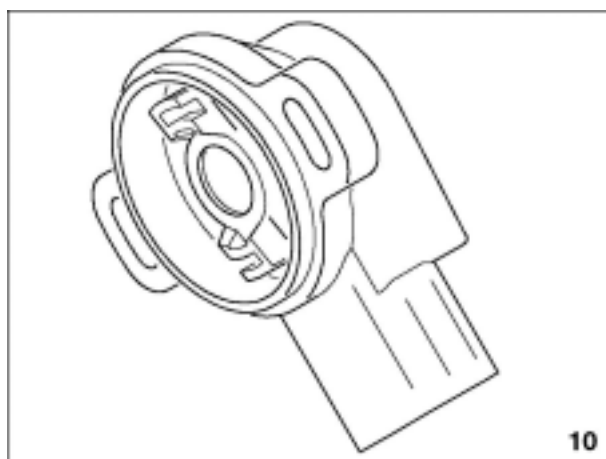

- 11 IMMOBILIZER ANTENNA**
winding resistance 14 Ω

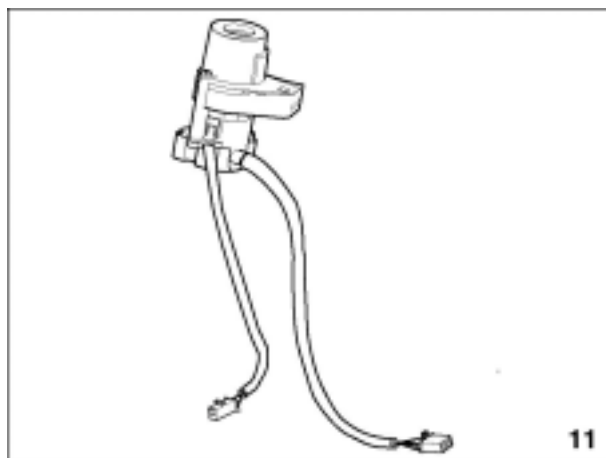

- 12 STARTING MOTOR**
peak absorption 120 A

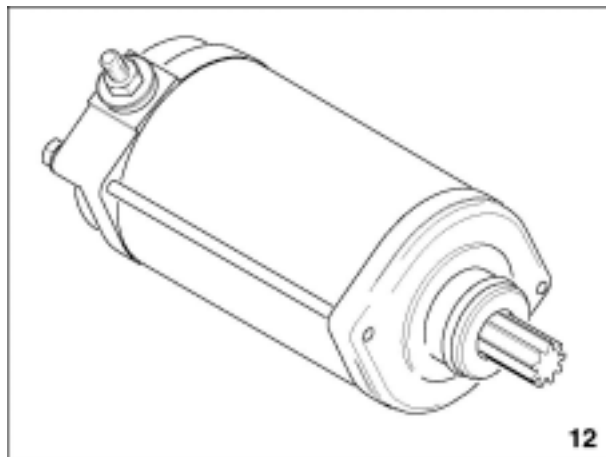

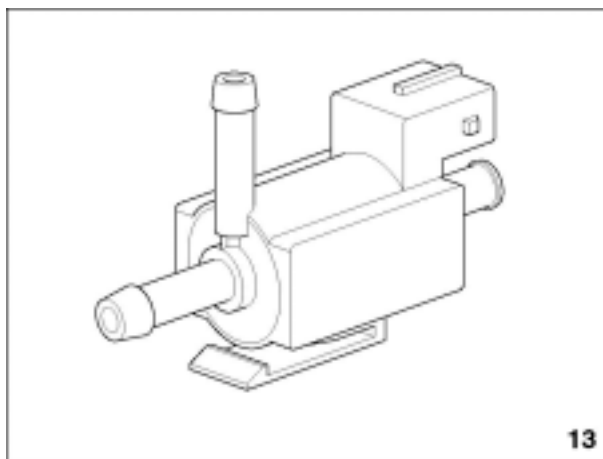
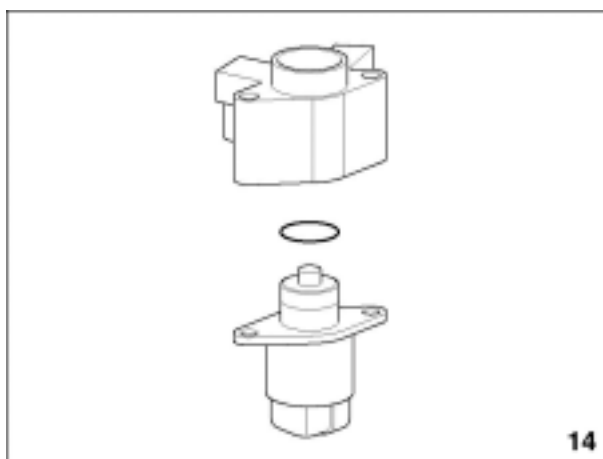
13 INTAKE FLAPwinding resistance 30 Ω **14 STEPPER**phase resistance 50 Ω **15 GENERATOR**

three-phase generator

winding resistance 0.4 Ω

output voltage 75 V AC (measure with generator disconnected from electrical system and engine running at 4000 rpm)

**16 RECHARGE VOLTAGE**

voltage 13.8 V across battery terminals (with engine running at 4000 rpm)

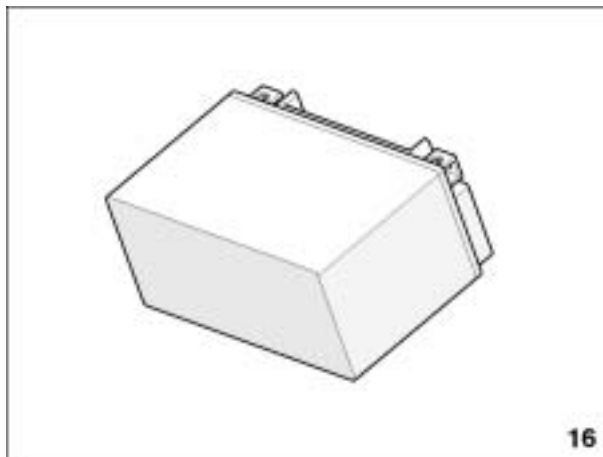

17 FUEL PUMP

absorption 3.9 A

**18 FUEL RESERVE SENSOR**

The vehicle does not have a fuel gauge but rather a simple led which turns on when the fuel level is below 3.7 litres :
The sensor starts conducting (and the led turns on) 30 seconds after it is no longer wetted by fuel.

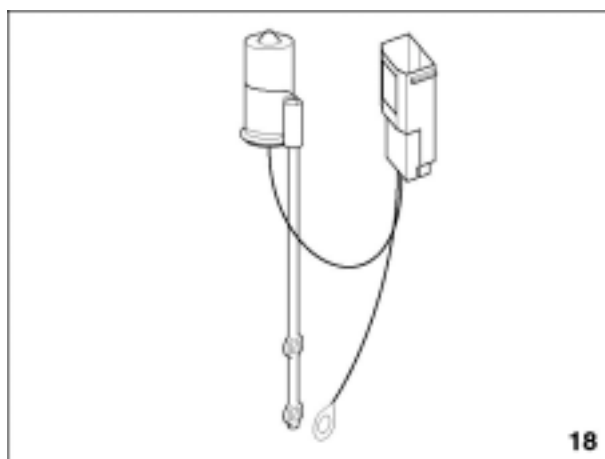

19 ECU

ECU pinout

Connector A

Pin	Designation	Signal type
1	Rear cylinder coil control	Power output
2	n.c.	
3	Atmospheric pressure sensor power (5V)	Power
4	Atmospheric pressure sensor power (ground)	Power
5	Engine speed sensor signal	Frequency input
6	n.c.	
7	Air temperature sensor signal	Analogue input
8	n.c.	
9	n.c.	
10	Minimum oil pressure sensor signal	Digital input
11	Water temperature sensor signal	Analogue input
12	Manifold pressure sensor signal	Analogue input
13	n.c.	
14	Purge valve control	Power output
15	Front cylinder injector 2 control	Power output
16	n.c.	
17	n.c.	
18	Atmospheric pressure sensor signal	Analogue input
19	Engine speed sensor signal (ground)	Power
20	Timing sensor (ground)	Power
21	Air temperature sensor signal	Power
22	n.c.	
23	n.c.	
24	Throttle potentiometer signal	Analogue input
25	Throttle potentiometer power (ground)	Power
26	n.c.	
27	Water temperature sensor signal (ground)	Power
28	Manifold pressure sensor power (ground)	Power
29	n.c.	
30	n.c.	
31	n.c.	
32	n.c.	
33	Rear cylinder injector 1 control	Power output
34	Timing sensor	Analogue input
35	D stepper timing	Power output
36	A stepper timing	Power output
37	C stepper timing	Power output
38	B stepper timing	Power output
39	Throttle potentiometer power (5 V)	Power
40	Manifold pressure sensor power (5 V)	Power
41	Front cylinder coil control	Power output

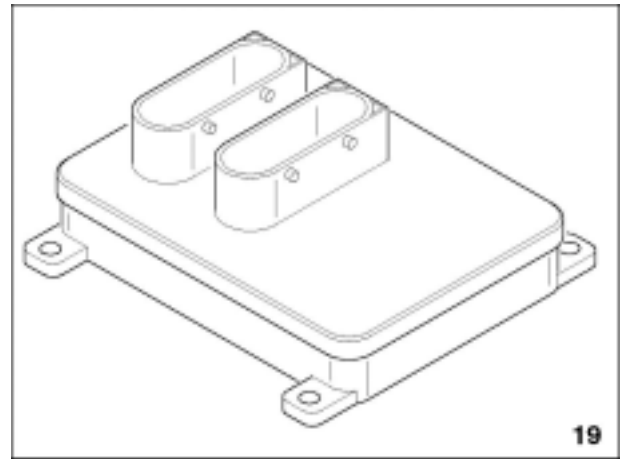

Connector B

Pin	Designation	Signal type
1	ECU power (ground)	Power
2	ECU power (ground)	Power
3	Fan	Power output
4	n.c.	
5	Lambda sensor heater control	Power output
6	Vehicle speed sensor signal	Frequency input
7	n.c.	
8	n.c.	
9	Fall sensor signal	Digital input
10	n.c.	
11	ECU power (15)	Power
12	Lambda sensor signal (ground)	Power
13	ECU power (ground)	Power
14	n.c.	
15	Intake flap control	Power output
16	n.c.	
17	Injection relay control	Digital output
18	n.c.	
19	n.c.	
20	Vehicle speed sensor power (ground)	Power
21	Ignition request	Digital input
22	n.c.	
23	Side stand switch	Digital input
24	Diagnostics line (K)	Comms line
25	Clutch switch	Digital input
26	Stop switch	Digital input
27	CAN Line (L)	Comms line
28	CAN Line (H)	Comms line
29	Fuel pump control	Power output
30	n.c.	
31	Starter relay control	Digital output
32	ECU power (ground)	Power input
33	n.c.	
34	n.c.	
35	n.c.	
36	Power 12 V	Power
37	Lambda sensor signal	Analogue input
38	n.c.	
39	n.c.	
40	Neutral gear switch	Digital input
41	ECU power (ground)	Power

20 HEAD LAMP

Low beam (halogen)	12 V – 55 W H11 x 2
High beam (halogen)	12 V – 55 W H11 x 2
Front parking light	12 V – 5W

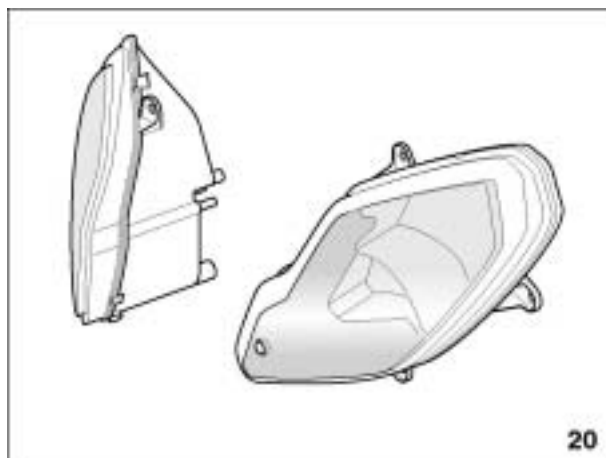

20

21 TAIL LIGHT

Number plate light 12 V – 5W

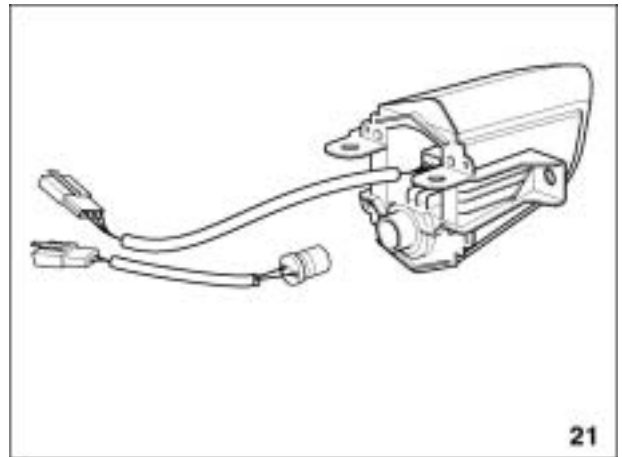
**22 SECONDARY FUSES**

- A – From key to: lights relay, horn, parking lights (5A).
- A – From key to: direction indicators, dashboard (5A).
- C – From battery to: positive under key at ECU (5 A).
- D – From battery to: speed sensor, fuel pump, relay, starter, lambda sensor (15 A).
- E – From battery to: Fan relay, coils, injectors, intake flap, camshaft sensor (15 A)
- F – From ignition switch to: high beam, low beam (20 A).

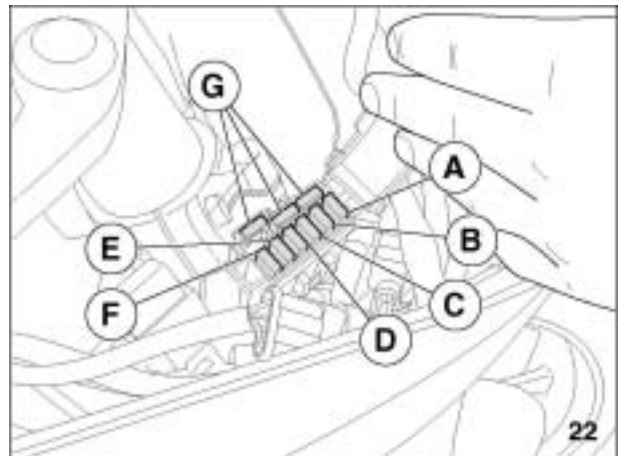
IMPORTANT There are three spare fuses (G).**23 MAIN FUSES**

- H – battery recharge and vehicle loads (red and red/white cables) + immobilizer (30 A).
- I – injection loads (red and red/black cables) (30 A).

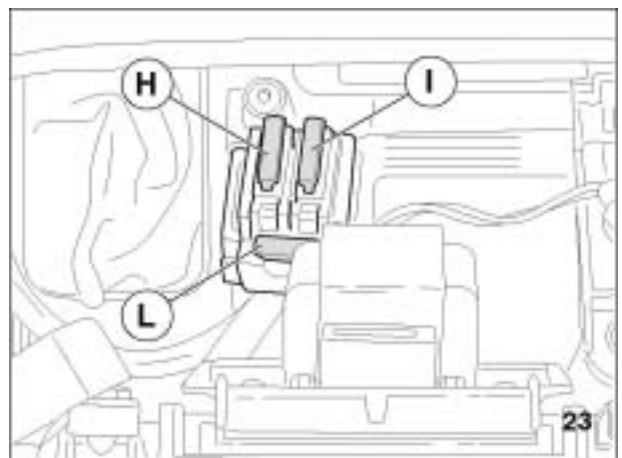
IMPORTANT There is one spare fuse (L).

7.1.3. CAN LINE

A CAN (Controller Area Network) line is a connection between the vehicle's various electronic components which operates like a computer (Internet) network.

The use of CAN lines greatly simplifies the electrical system and its overall weight.

This type of network makes unnecessary the duplication of sensors around the vehicle, inasmuch as their signals are shared by both electronic control systems (dashboard and ECU).

ADVANTAGES OF THE CAN SYSTEM

- Reduction of the number of cables : the CAN line runs on a double cable between its nodes.
- The nodes are also capable of isolating errors without causing the system to breakdown (Fault Confinement).
- Robustness: the signal is transmitted over two cables and the reading is differential (voltage difference between the two signals on separate cables). If the two signals are perturbed by external factors, their difference is not effected.
- Speed of communications : bandwidth is around 250 kbps (data is transmitted to the nodes every 20 ms = 50 times a second).

THE CAN (CONTROLLER AREA NETWORK) PROTOCOL

The CAN comms protocol is a CSMA/CD (Carrier Sense Multiple Access /w Collision Detection) protocol.

In order to transmit, each node must first check that the BUS connecting it to all the other nodes is free (Carrier Sense); only then can it transmit on the BUS. If there is no activity on the BUS, all nodes are able to transmit over it (Multiple Access). If two nodes start transmitting at the same time, they detect the collision (Collision Detection) and arbitrate the situation based on a set priority ranking (the messages are unaltered during the arbitration and the higher priority message is not delayed).

The CAN protocol is message-oriented, not address-oriented. The message itself is composed of a number of component frames, each of which has a set significance : message priority, data, error checking, reception confirmation, etc.. All nodes receive all messages on the BUS (with reception confirmation or error) and each node decides whether the message is to be handled or discarded. Each node can also request information from other nodes (RTR = Remote Transmit Request).

STARTING

Before it starts the engine the ECU waits for a permissive from the dashboard over the CAN which identifies the engine model V990 (this information resides in the dashboard).

No sensor (apart from the fuel reserve sensor) is connected directly to the dashboard ; the dashboard reads from the ECU. All sensors/switches are connected to the ECU.

DASHBOARD INDICATOR ACTIVATION :

Indicator	LED	Activation
Neutral	SMD green	ECU via CAN
Side stand	SMD amber	
EFI	SMD red	
Oil pressure		

CAN-BUS LINE SIGNALS :

Transmitted signal	Frequency (Hz)
Engine speed	50
Speed	
Diagnostics	
Neutral (indicator)	
Stand (indicator)	
Oil pressure (indicator)	
Water temperature	
Signal sent	Frequency (Hz)
Odometer (stored in injection controller memory for future applications)	50
Model ID	

If data is not received (CAN line damaged/disconnected), the red line, warning and stand indicators come on, the neutral indicator stays off, revolution counter and speedometer stay at zero, battery voltage reads 9.0V and the water temperature reading flashes ERR.

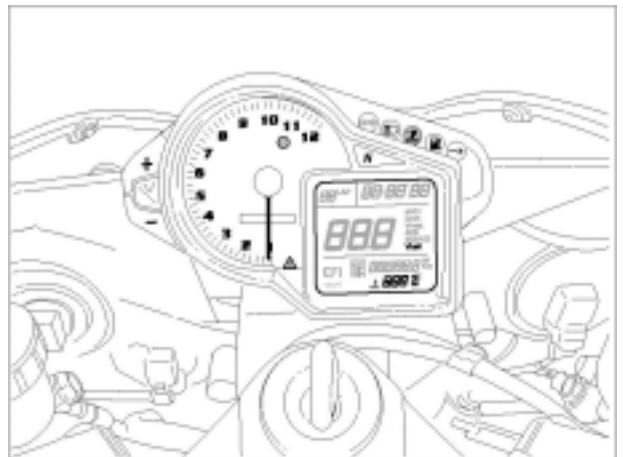

7.1.4. IMMOBILIZER

IMMOBILIZER

The vehicle is equipped with an immobilizer which stops the engine being started if the correct code is not entered. The code is stored in the transponder in each of the two keys supplied with the vehicle. The transponder data is read by an antenna mounted in the ignition switch which is directly connected to the ECU.

The immobilizer is completely independent of the CAN.



The immobilizer mode is indicated by a led on the dashboard, as follows:

- immobilizer de-activated: led off
 - immobilizer activated: led flashes every 3 seconds (warning function)
 - incorrect key: led flashes every second
- The led stops flashing after 240 hours to conserve energy.

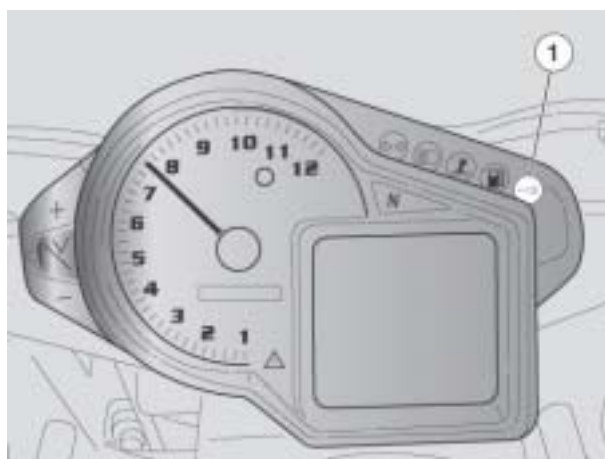

STORING NEW KEY CODES (VIRGIN MEMORY)

When the immobilizer ECU is first powered up, its memory is virgin and the led stays on without flashing. To store the first two key codes :

- run a key ON cycle with the first key : the led will switch off for 0.5 sec and turn on again. When it turns on, turn the key to OFF.
- turn the second provided key to ON within 20 seconds. the led will switch off and immediately flash 4 times.

Now turn the key to OFF. The two keys are now stored and the immobilizer is activated (led flashes every 3 seconds as a warning).

The two keys are now stored and the immobilizer is activated whenever the key is turned to OFF (led flashes every 3 seconds as a warning)

If power fails after the first key is stored, the system will reset (first key data also cancelled). After the first key has been stored, all vehicle and dashboard functions are enabled. The key is not stored definitively if the second key is not stored within 20 seconds.

ADDITIONAL KEY STORE PROCEDURE

The immobilizer system can recognise up to 4 keys. The storage procedure can only be done at the dealership with a Master Key.

The storage procedure cancels the existing codes, so that if the client wishes to store new keys he must come to the Dealership with all the keys he wishes to use. The storage procedure is as follows :

1. with a customer key (already stored), turn from key ON to OFF
2. fit the Master Key within 20 seconds, thus enabling the store procedure. The led will stay on continuously
3. insert and run key-ON's in sequence with all the keys to be stored. The led will switch off for 0.5 seconds after each key has been successfully stored.
4. After each key has been stored, the system waits for a new key for 20 seconds (led on continuously) after which the procedure self-terminates (the led flashes once for each key and then turns off).



7.1.5. WIRING DIAGRAM

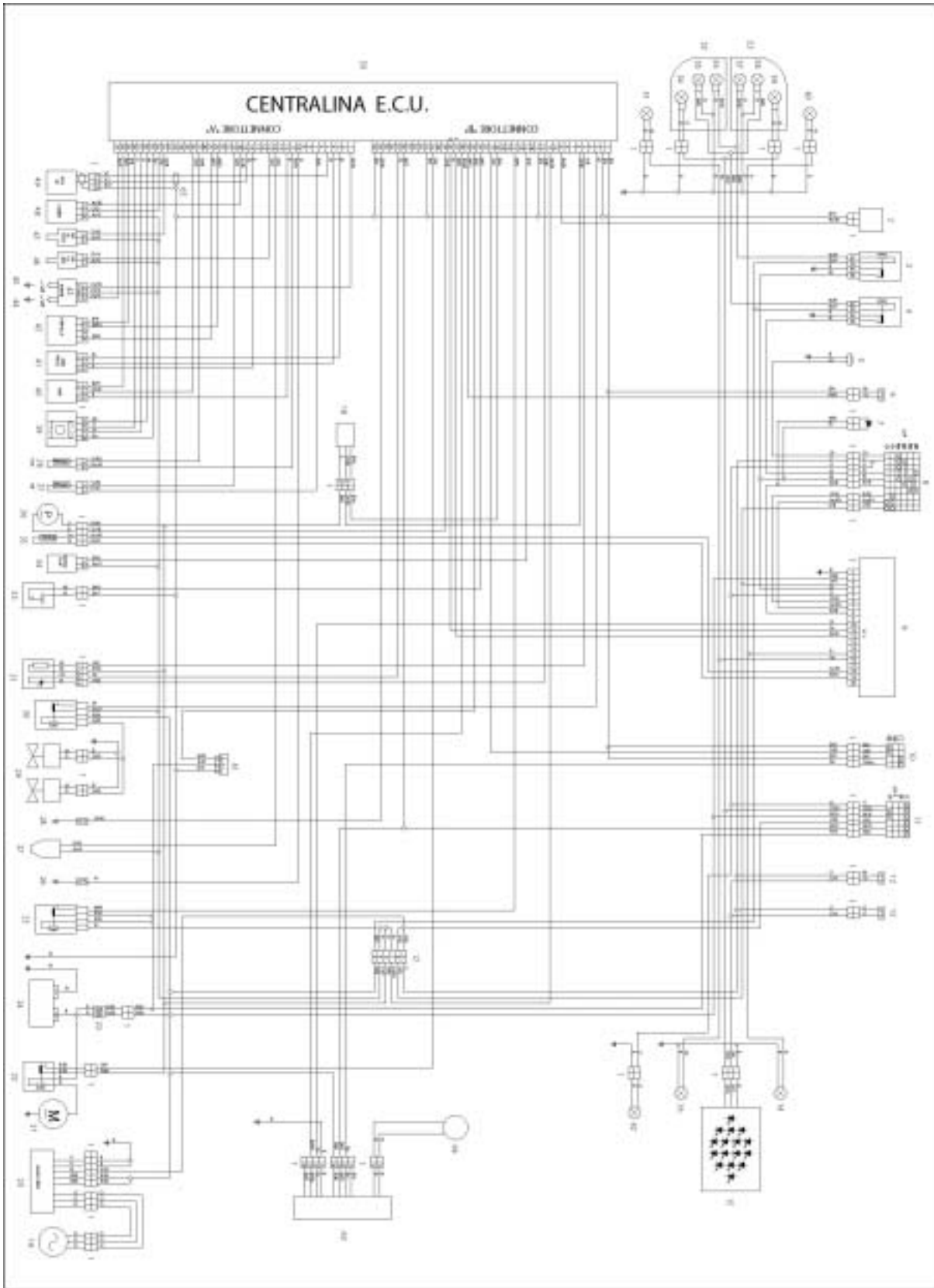

1. Multiple connectors
2. Fall sensor
3. High beam relay
4. Low beam relay
5. Horn
6. Clutch switch
7. Lights/lap diode
8. Left dimmer switch
9. Dashboard
10. Right dimmer switch
11. Key-operated switch
12. Front brake light switch
13. Rear brake light switch
14. Rear right direction indicator
15. Tail light (LED)
16. Rear left direction indicator
17. Auxiliary fuses
18. Speed sensor
19. Flywheel
20. Voltage regulator
21. Starter motor
22. Starter relay
23. Main fuses
24. Battery
25. Injection relay
26. Oil pressure sensor
27. Purge valve (California only)
28. Neutral light switch
29. Cooling fans
30. Fan relay
31. Lambda sensor
32. -
33. Side stand switch
34. Intake flap
35. Fuel sensor
36. Fuel pump
37. Air thermistor
38. Water thermistor
39. Automatic choke
40. Intake pressure sensor
41. Atmospheric pressure sensor
42. Throttle sensor
43. Twin coil
44. Front cylinder spark plug
45. Rear cylinder spark plug
46. Front cylinder injector
47. Rear cylinder injector
48. Camshaft sensor
49. Pick-up
50. Engine Control Unit (ECU)
51. Front left direction indicator
52. Left headlamp
53. Right headlamp
54. Left beam parking light
55. Left low beam bulb
56. Left high beam bulb
57. Right high beam bulb
58. Right low beam bulb
59. Right beam parking light
60. Front right direction indicator
61. Diagnostics socket
62. Number plate light
63. Immobilizer control unit
64. Immobilizer antenna
65. Pick-up cables shielding

SECONDARY FUSES:

- | | | |
|----------|-----|--|
| A | 5A | LIGHT RELAY, STOP, HORN, PARKING LIGHTS |
| B | 5A | DIRECTION INDICATORS, DASHBOARD |
| C | 5A | KEY-ENABLED POSITIVE POLE, TO E.C.U. |
| D | 15A | SPEED SENSOR, FUEL PUMP, STARTER RELAY, LAMBDA |
| E | 15A | FAN RELAY, COILS, INJECTORS, INTAKE FLAP, CAMS, CANISTER |
| F | 20A | LOW/HIGH BEAM |

WIRE COLOUR CODING

- | | |
|-----------|------------|
| Ar | Orange |
| Az | Light blue |
| B | Blue |
| Bi | White |
| G | Yellow |
| Gr | Grey |
| M | Brown |
| N | Black |
| R | Red |
| V | Green |
| Vi | Violet |
| Ro | Pink |



aprilia s.p.a.
via G. Galilei, 1
30033 Noale (VE) Italy
tel. +39 041.5829111
fax +39 041.5829190
www.aprilia.com
www.serviceaprilia.com