



SERVICE STATION MANUAL

2Q000333



RSV4 RR-RF



SERVICE STATION MANUAL

RSV4 RR-RF

THE VALUE OF SERVICE

Due to continuous updates and technical training programmes specific to Aprilia products, only **Aprilia Official Network** mechanics know this vehicle fully and have the specific tools necessary to carry out maintenance and repair operations correctly.

The reliability of the vehicle also depends on its mechanical conditions. Checking the vehicle before riding it, performing maintenance correctly and using only **original Aprilia spare parts** are essential factors for the reliability of your vehicle!

For information on the nearest **Official Dealer and/or Service Centre** consult our website:
www.aprilia.com

Only by requesting original Aprilia spare parts can you be of purchasing products that were developed and tested during the design and development of the vehicle itself. All Aprilia original spare parts undergo quality control procedures to guarantee reliability and durability.

The descriptions and images in this publication are given for illustrative purposes only.

While the basic features as described and illustrated in this manual remain unchanged, Piaggio & C. S.p.A. reserves the right, at any time and without being required to update this publication beforehand, to make any changes to components, parts or accessory supplies which it deems necessary to improve the product, or which are required for manufacturing or commercial reasons.

Not all versions/models shown in this publication are available in all countries. The availability of individual versions/models should be confirmed with the official Aprilia sales network.

The Aprilia trademark is the property of Piaggio & C. S.p.A.

© Copyright 2017 - Piaggio & C. S.p.A. All rights reserved. Reproduction of this publication in whole or in part is prohibited.

Piaggio & C. S.p.A. Viale Rinaldo Piaggio, 25 - 56025 PONTEDERA (PI), Italy
www.piaggio.com

SERVICE STATION MANUAL

RSV4 RR-RF

This manual provides the main information to carry out regular maintenance operations on your vehicle. This manual is intended to aprilia Dealers and their qualified mechanics; several concepts have been deliberately omitted as they are considered unnecessary. As it is not possible to include complete mechanical notions in this manual, users should have basic mechanical knowledge or minimum knowledge about the procedures involved when repairing scooters. Without this knowledge, repairing or checking the vehicle may be inefficient or even dangerous. As the vehicle repair and check procedures are not described in detail, be extremely cautious so as not to damage components or injure individuals. In order to optimise customer satisfaction when using our vehicles, aprilia s.p.a. commits itself to continually improve its products and the relative documentation. The main technical modifications and changes in repair procedures are communicated to all aprilia Sales Outlets and its International Subsidiaries. These changes will be introduced in the subsequent editions of the manual. In case of need or further queries on repair and check procedures, consult aprilia CUSTOMER DEPARTMENT, which will be prepared to provide any information on the subject and any further communications on updates and technical changes related to the vehicle.

NOTE Provides key information to make the procedure easier to understand and carry out.

CAUTION Refers to specific procedures to carry out for preventing damages to the vehicle.

WARNING Refers to specific procedures to carry out to prevent injuries to the repairer.



Personal safety Failure to completely observe these instructions will result in serious risk of personal injury.



Safeguarding the environment Sections marked with this symbol indicate the correct use of the vehicle to prevent damaging the environment.



Vehicle intactness The incomplete or non-observance of these regulations leads to the risk of serious damage to the vehicle and sometimes even the invalidity of the guarantee



INDEX OF TOPICS

CHARACTERISTICS

CHAR

SPECIAL TOOLS

S-TOOLS

MAINTENANCE

MAIN

ELECTRICAL SYSTEM

ELE SYS

ENGINE FROM VEHICLE

ENG VE

ENGINE

ENG

POWER SUPPLY

P SUPP

SUSPENSIONS

SUSP

CHASSIS

CHAS

BRAKING SYSTEM

BRAK SYS

COOLING SYSTEM

COOL SYS

BODYWORK

BODYW

PRE-DELIVERY

PRE DE

INDEX OF TOPICS

CHARACTERISTICS

CHAR

Rules

Safety rules

Carbon monoxide

If you need to keep the engine running while working on the vehicle, please ensure that you do so in an open or very well ventilated area. Never run the engine in an enclosed area. If you do work in an enclosed area, make sure to use a fume extraction system.

CAUTION



EXHAUST EMISSIONS CONTAIN CARBON MONOXIDE, A POISONOUS GAS WHICH CAN CAUSE LOSS OF CONSCIOUSNESS AND EVEN DEATH.

Fuel

CAUTION



FUEL USED TO DRIVE EXPLOSION ENGINES IS HIGHLY INFLAMMABLE AND CAN BECOME EXPLOSIVE UNDER SPECIFIC CONDITIONS. IT IS THEREFORE RECOMMENDED TO CARRY OUT REFUELLING AND MAINTENANCE PROCEDURES IN A VENTILATED AREA WITH THE ENGINE SWITCHED OFF. DO NOT SMOKE DURING REFUELLING OR NEAR FUEL VAPOUR. AVOID ANY CONTACT WITH NAKED FLAME, SPARKS OR OTHER HEAT SOURCES WHICH MAY CAUSE IGNITION OR EXPLOSION.

**DO NOT ALLOW FUEL TO DISPERSE INTO THE ENVIRONMENT.
KEEP OUT OF THE REACH OF CHILDREN.**

Hot parts

The engine and the exhaust system components get very hot and remain in this condition for a certain time interval after the engine has been switched off. Before handling these components, make sure that you are wearing insulating gloves or wait until the engine and the exhaust system have cooled down.

Coolant

The coolant contains ethylene glycol which, under certain conditions, can become flammable.

When it burns, ethylene glycol produces an invisible flame which however can cause burns.

CAUTION



TAKE PARTICULAR CARE NOT TO SPILL COOLANT ONTO HOT PARTS OR THE ENGINE AND EXHAUST SYSTEM; THE FLUID MAY CATCH FIRE AND BURN WITH INVISIBLE FLAMES. WHEN CARRYING OUT MAINTENANCE OPERATIONS, IT IS ADVISABLE TO WEAR LATEX GLOVES. WHILE POISONOUS, COOLANT HAS A SWEET TASTE WHICH MAKES IT EXTREMELY APPEALING TO ANIMALS. NEVER LEAVE COOLANT IN OPEN CONTAINERS WHERE IT MAY BE REACHED AND DRUNK BY AN ANIMAL.

**KEEP OUT OF THE REACH OF CHILDREN.
NEVER REMOVE THE RADIATOR CAP WHILE THE ENGINE IS STILL HOT. COOLANT IS UNDER PRESSURE AND MAY CAUSE BURNS.**

Used engine oil and transmission oil

CAUTION



WHEN CARRYING OUT MAINTENANCE OPERATIONS, IT IS ADVISABLE TO WEAR PROTECTIVE IMPERMEABLE GLOVES.

THE ENGINE OR GEARBOX OIL MAY CAUSE SERIOUS INJURIES TO THE SKIN IF HANDLED FOR PROLONGED PERIODS OF TIME AND ON A REGULAR BASIS.

WASH YOUR HANDS CAREFULLY AFTER HANDLING OIL.

HAND THE OIL OVER TO OR HAVE IT COLLECTED BY THE NEAREST USED OIL RECYCLING COMPANY OR THE SUPPLIER.

DO NOT DISPOSE OF OIL IN THE ENVIRONMENT

KEEP OUT OF THE REACH OF CHILDREN.



THE BRAKE FLUID MAY DAMAGE PAINTED, PVC OR RUBBER SURFACES. WHEN SERVICING THE BRAKING SYSTEM, PROTECT THESE COMPONENTS WITH A CLEAN CLOTH. ALWAYS WEAR PROTECTIVE GOGGLES WHEN SERVICING THE BRAKING SYSTEM. THE BRAKE FLUID IS EXTREMELY DANGEROUS TO THE EYES. IN THE EVENT OF ACCIDENTAL CONTACT WITH THE EYES, RINSE THEM IMMEDIATELY WITH PLENTY OF COLD, CLEAN WATER AND SEEK MEDICAL ADVICE.

KEEP OUT OF THE REACH OF CHILDREN.

Battery electrolyte and hydrogen gas

CAUTION



THE BATTERY ELECTROLYTE IS TOXIC, CORROSIVE AND AS IT CONTAINS SULPHURIC ACID, IT CAN CAUSE BURNS WHEN IN CONTACT WITH THE SKIN. WHEN HANDLING BATTERY ELECTROLYTE, WEAR TIGHT-FITTING GLOVES AND PROTECTIVE APPAREL. IN THE EVENT OF SKIN CONTACT WITH THE ELECTROLYTIC FLUID, RINSE WELL WITH PLENTY OF CLEAN WATER. IT IS PARTICULARLY IMPORTANT TO PROTECT YOUR EYES BECAUSE EVEN TINY AMOUNTS OF BATTERY ACID MAY CAUSE BLINDNESS. IF THE FLUID GETS IN CONTACT WITH YOUR EYES, WASH WITH ABUNDANT WATER FOR FIFTEEN MINUTES AND CONSULT AN EYE SPECIALIST IMMEDIATELY. THE BATTERY RELEASES EXPLOSIVE GASES; KEEP IT AWAY FROM FLAMES, SPARKS, CIGARETTES OR ANY OTHER HEAT SOURCES. ENSURE ADEQUATE VENTILATION WHEN SERVICING OR RECHARGING THE BATTERY.

KEEP OUT OF THE REACH OF CHILDREN.

BATTERY LIQUID IS CORROSIVE. DO NOT POUR OR SPILL ON PLASTIC COMPONENTS IN PARTICULAR. ENSURE THAT THE ELECTROLYTIC ACID IS COMPATIBLE WITH THE BATTERY BEING ACTIVATED.

Maintenance rules

GENERAL PRECAUTIONS AND INFORMATION

When repairs, disassembly and reassembly of the vehicle is carried out, follow the following recommendations strictly.

BEFORE DISASSEMBLING COMPONENTS

- Remove the dirt, mud, dust and foreign objects from the vehicle before disassembling components. Wherever required, use the special tools designed for this vehicle.

DISASSEMBLING COMPONENTS

- Do not loosen and/or tighten the screws and nuts using pliers or other tools, but always use the specific wrench.
- Mark the positions on all the connection joints (hoses, cables, etc.) before separating them and identify them with different distinctive marks.
- Each piece should be clearly marked in order to be identified during the installation phase.
- Carefully clean and wash the disassembled components with detergents with a low flammability grade.
- Keep the coupled parts together because they have "adapted" to one another following normal wear.
- Some components must be used together or replaced entirely.
- Keep away from heat sources.

REASSEMBLING COMPONENTS

CAUTION

BEARINGS MUST ROTATE FREELY, WITHOUT JAMMING AND/OR NOISE, OTHERWISE, THEY NEED TO BE REPLACED.

- Only use ORIGINAL Aprilia SPARE PARTS.
- Comply with lubricant and consumables use guidelines.
- Lubricate parts (whenever possible) before reassembling them.
- When tightening nuts and screws, start either from the components with the largest diameter or from the innermost components, proceeding diagonally. Tighten nuts and screws in successive steps before applying the tightening torque.
- Always replace self-locking nuts, washers, sealing rings, circlips, O-rings (OR), cotter pins and screws with new parts if the thread is damaged.
- When assembling the bearings, make sure to lubricate them well.
- Check that each component is assembled correctly.
- After a repair or routine maintenance, carry out pre-ride checks and test the vehicle on private grounds or in an area with low traffic.
- Clean all mating surfaces, oil seal rims and gaskets before refitting. Smear a thin layer of lithium-based grease on the oil seal rims. Reassemble oil seals and bearings with the brand or batch number facing outward (visible side).

ELECTRICAL CONNECTORS

Electric connectors must be disconnected as described below; failure to comply with this procedure causes irreparable damage to both the connector and the wiring harness:

Press the relative safety clips, if applicable.

- Grip the two connectors and disconnect them by pulling them in opposite directions.
- If any signs of dirt, rust, moisture, etc. are noted, clean the inside of the connector carefully with a jet of compressed air.
- Ensure that the cables are correctly fastened to the internal connector terminals.
- Then connect the two connectors, ensuring that they couple correctly (if fitted with clips, you will hear them "click" into place).

CAUTION

DO NOT DISCONNECT CONNECTORS BY PULLING THE CABLES.

NOTE

THE TWO CONNECTORS CAN ONLY BE CONNECTED IN ONE DIRECTION: CONNECT THEM THE RIGHT WAY ROUND.

TIGHTENING TORQUES**CAUTION**

IF UNSCREWING A SELF-LOCKING NUT, IT MUST BE REPLACED WITH A NEW ONE.

CAUTION

REMEMBER THAT THE TIGHTENING TORQUE FOR ALL THE FIXING ELEMENTS LOCATED ON WHEELS, BRAKES, WHEEL AXLES AND OTHER SUSPENSION COMPONENTS PLAY A FUNDAMENTAL ROLE IN GUARANTEEING THE SAFETY OF THE VEHICLE AND MUST BE KEPT AT THE PRESCRIBED VALUES. REGULARLY CHECK THE TIGHTENING TORQUE OF THE FIXING ELEMENTS AND ALWAYS USE A TORQUE WRENCH WHEN REFITTING. IF THESE WARNINGS ARE NOT OBSERVED, ONE OF THESE COMPONENTS COULD LOOSEN AND COME OFF, BLOCKING A WHEEL OR CAUSING OTHER PROBLEMS THAT WOULD COMPROMISE MANOEUVRABILITY, LEADING TO A CRASH WITH THE RISK OF SERIOUS INJURY OR EVEN DEATH.

Running-in

Running the engine in correctly is essential for ensuring engine longevity and functionality. Twisty roads and gradients are ideal for running in the engine, brakes and suspension effectively. Vary your riding speed during the running in period. This ensures that components operate in "loaded" conditions and then "unloaded" conditions, allowing the engine components to cool.

CAUTION

THE FULL PERFORMANCE OF THE VEHICLE IS ONLY AVAILABLE AFTER THE SERVICE AT THE END OF THE RUNNING IN PERIOD.

Follow the guidelines detailed below:

- Do not twist the throttle grip abruptly and completely when the engine is working at a low revs, either during or after run-in.
- During the first 100 Km (62 miles) use the brakes gently, avoiding sudden or prolonged braking. That is to permit the adequate adjustment of the pad friction material to the brake discs.
- It is recommended, during the first 1000 km (621 mi), not to exceed 7500 rpm and 9500 rpm up 2000 km (1243 mi).



AFTER THE SPECIFIED MILEAGE, TAKE YOUR VEHICLE TO AN Official Aprilia Dealer FOR THE CHECKS INDICATED IN THE "RECOMMENDED PRODUCTS" TABLE IN THE SCHEDULED MAIN-

TENANCE SECTION TO AVOID INJURING YOURSELF, OTHERS AND /OR DAMAGING THE VEHICLE.

Vehicle identification

SERIAL NUMBER LOCATION

These numbers are necessary for vehicle registration.

NOTE

ALTERING IDENTIFICATION NUMBERS MAY BE SERIOUSLY PUNISHABLE BY LAW. IN PARTICULAR, MODIFYING THE CHASSIS NUMBER IMMEDIATELY VOIDS THE WARRANTY.

This number consists of numbers and letters, as in the example shown below.

ZD4RKE000YSXXXXXX

KEY:

ZD4: WMI (World manufacturer identifier) code;

KE: model;

000: RF or RR (Europe); **U00:**RF or RR (USA)

0: free digit;

Y: year of manufacture;

S: production plant (S= Scorzè);

XXXXXX: serial number (6 digits);

CHASSIS NUMBER

The chassis number is stamped on the right hand side of the headstock.



ENGINE NUMBER

The engine number is printed on the base of the engine crankcase, left hand side.

Engine No.

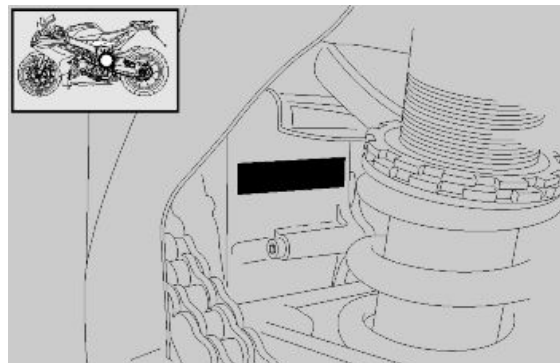

Dimensions and mass

WEIGHT AND DIMENSIONS

Specification	Desc./Quantity
Max. length	2,055 mm (80.90 in)
Max. width (at handlebar)	735 mm (28.94 in)
Max. height (to top fairing)	1,150 mm (45.27 in)
Wheelbase	1,435 mm (56.50 in)
Kerb weight	204 kg (449.74 lb)
Weight fully loaded	279 kg (615.09 lb) (only rider)

Engine

ENGINE

Specification	Desc./Quantity
Model	V4
Type	65° longitudinal V-4, 4-stroke, 4 valves per cylinder, double overhead camshafts.
Engine capacity	999 cm ³ (60.96 cu in)
Bore / stroke	78 mm / 52.26 mm (3.07 in / 2.06 in)
Compression ratio	13.5 +/- 0.5: 1
Intake valve clearance	0.10 - 0.15 mm (0.0039 - 0.0059 in)
Exhaust valve clearance	0.20 - 0.25 mm (0.0079 - 0.0098 in)
Engine idle speed	1500 +/- 100 rpm
Engine revs at maximum speed	14,200 +/- 100 rpm
Clutch	Multi plate wet clutch with mechanical control lever on left side of the handlebar. Anti-juddering and slipper clutch systems
Start-up	Electric
Timing system	Morse chain on intake camshaft, cam to cam gear, bucket tappets and valve clearance adjustments with calibrated pads
Lubrication	Wet sump with oil radiator
Oil pump	Dual trochoidal pump (lubrication + cooling)
Oil filter	With external cartridge filter
Cooling	Liquid
Cooling system	3-way thermostatic valve, cooling radiator with electric fan and expansion tank
Coolant pump	Centrifugal bearingless aspirating pump with integrated ceramic gasket
Air filter	In cotton

Transmission

GEAR RATIOS

Specification	Desc./Quantity
Primary drive ratio	44 / 73 (with gears)
Drive ratio, 1st gear	15 / 39 (secondary)
Drive ratio, 2nd gear	16 / 33 (secondary)
Drive ratio, 3rd gear	20 / 34 (secondary)
Drive ratio, 4th gear	21 / 31 (secondary)
Drive ratio, 5th gear	23 / 31 (secondary)
Drive ratio, 6th gear	27 / 34 (secondary)
Final drive ratio	16 / 41

TRACTION CONTROL

Specification	Desc./Quantity
a-PRC system	(Aprilia Performance Ride Control), which includes traction control, wheelie control, launch control and clutchless gear shift functions both upshifting and downshifting.

Capacities

CAPACITY

Specification	Desc./Quantity
Fuel tank (reserve included)	18.5 l (4.07 UKgal; 4.88 US gal)
Fuel tank reserve	4 l (0.88 UK gal; 1.06 US gal)
Engine oil	oil and filter change 4.1 l (0.90 UK gal)
Coolant	2.7 l (0.59 UK gal)
Seats	2
Maximum weight limit	401 kg (884.05 lb) (rider + passenger + luggage)

Drive chain

DRIVE CHAIN

Specification	Desc./Quantity
Type	525 With sealed master link
Model	Regina 110 links

Electrical system

ELECTRICAL SYSTEM

Specification	Desc./Quantity
Spark plugs	NGK-R CR9EKB Alternatively: NGK-R CR9EB NGK-R CR10E (for competition use)
Electrode gap	0.7 - 0.8 mm (0.027 - 0.031 in)
Battery	YUASA YT12A-BS, 12 V 9.5 Ah or YUASA YTZ10S, 12 V 8.6 Ah
Coils	Stick coil
Recharging system	Flywheel with rare earth magnets
Alternator	450 W
Main fuses	15A - 30A
Secondary fuses	5A - 7.5A - 10A - 15A (3)
ABS fuses	15 A - 30 A

BULBS

Specification	Desc./Quantity
High beam/low beam light	12 V - 55 W H7
Front daylight running lights	LED
Turn indicator light	LED
Rear daylight running light /stop light	LED
License plate light	12 V - 5 W

INDICATOR LAMPS

Specification	Desc./Quantity
ABS	LED
Cruise control	LED
High beam light	LED
Fuel reserve	LED
Turn indicators	LED
Overspeed threshold/shift light	LED
Immobilizer	LED
MI	LED
General warning	LED
Side stand	LED
a-PRC	LED

Frame and suspensions

CHASSIS

Specification	Desc./Quantity
Type	Adjustable aluminium, dual beam chassis with pressed and cast sheet elements.
Steering rake	26.5° (measurements with reference to bare chassis)

SUSPENSIONS

Specification	Desc./Quantity
Front fork - RSV4 1000 RF	Öhlins upside down units with adjustable hydraulic damping and 43 mm (1.69 in) diam. stanchions with Tin surface coating and NIX cartridge
Front fork - RSV4 1000 RR	Sachs upside-down stanchions with adjustable hydraulic damping and 43mm (1.69 in) diameter stanchions.
Front wheel stroke - RSV4 1000 RF	120 mm (4.72 in)
Front wheel stroke - RSV4 1000 RR	121 mm (4.76 in)
Rear shock absorber - RSV4 1000 RF	With progressive linkage with APS system. Öhlins shock absorber with adjustable spring preload, wheelbase, compression damping and rebound damping, with TTX system.
Rear shock absorber - RSV4 1000 RR	With progressive linkage with APS system. Sachs shock absorber with adjustable spring preload piggy-back, wheelbase, compression damping and rebound damping.
Rear wheel stroke - RSV4 1000 RF	116 mm (4.57 in)
Rear wheel stroke - RSV4 1000 RR	138.5 mm (5.45 in)

SIZES A AND B

Specification	Desc./Quantity
Size "A"	639.5 mm (25.18 in) (measurements refer to the bare chassis)
Size "B"	329.5 mm (12.97 in) (measurements refer to the bare chassis)

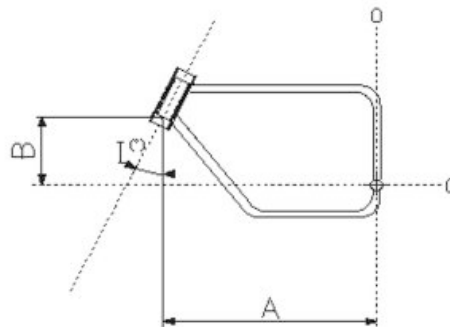

Brakes

BRAKES

Specification	Desc./Quantity
Front	Dual 330 mm (12.99 inches) diam. floating disc, forged radial-mounted single block callipers and four pistons 30 mm diam. (1.18 inches) and 2 pads - radial pump and brake pipe in metal braid.
Rear	disc brake -220 mm diam. (8.66 inches), 2-piston callipers - 32 mm diam. (1.25 inches) - pump with built-in tank and metal braid pipe.

Wheels and tyres

WHEEL RIMS

Specification	Desc./Quantity
Front wheel rim	3.50 x 17" RSV4 1000 RR - forged for the RSV4 1000 RF version
Rear wheel rim	6.00 x 17" RSV4 1000 RR - forged for the RSV4 1000 RF version

TYRES

Specification	Desc./Quantity
Tyre model	Pirelli DIABLO Supercorsa SP V2 Pirelli DIABLO Supercorsa SP
Front tyre	120/70 ZR17 (58W)
Inflation pressure	1 passenger: 2.3 bar (230 KPa) (33.36 PSI) 2 passengers: 2.5 bar (250 KPa) (36.26 PSI)
Rear tyre	200/55 ZR17 (78W) (*) 190/55 ZR17 (75W)
(*) With these dimensions use only Pirelli Diablo Supercorsa SP and Diablo Supercorsa SP V2 tyres.	
Inflation pressure	1 passenger: 2.5 bar (250 KPa) (36.26 PSI) 2 passengers: 2.8 bar (280 KPa) (40.61 PSI)

Supply

FUEL SUPPLY

Specification	Desc./Quantity
Fuel	Unleaded petrol max E10 (95 RON).

FUEL SUPPLY SYSTEM

Specification	Desc./Quantity
Throttle body diameter	48 mm (1.89 in)
Type	Electronic injection with 2 injectors per cylinder, 4 motorised throttle bodies (Ride by wire) with fixed height air intakes differentiated per main bearing (front/rear). 2 dynamic air intakes. Selectable multimap.

Tightening Torques

Chassis

Front side

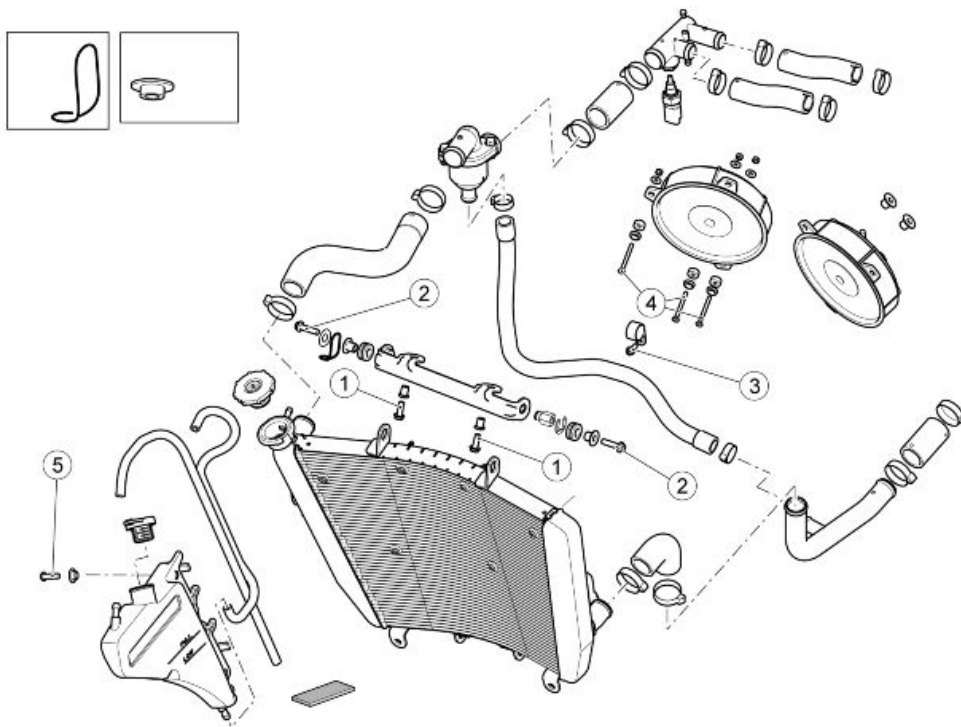

LIQUID

Pos.	Description	Type	Quantity	Torque	Notes
1	Flanged hex. head screws for fastening the water radiator support bracket to the frame	M6x20	2	10 Nm (7.38 lb ft)	-
2	Flanged hex. head screws for fastening the water radiator to the support bracket	M6x20	2	7 Nm (5.16 lb ft)	-
3	Screws for fastening the water bypass pipe tube gland	M5	1	6 Nm (4.43 lb ft)	-
4	Screws for fastening the electric fans to the water radiator	M4	6	0.5 Nm (0.37 lb ft)	-
5	Screw for fastening the expansion tank	M6	1	5 Nm (3.69 lb ft)	Loct. 243

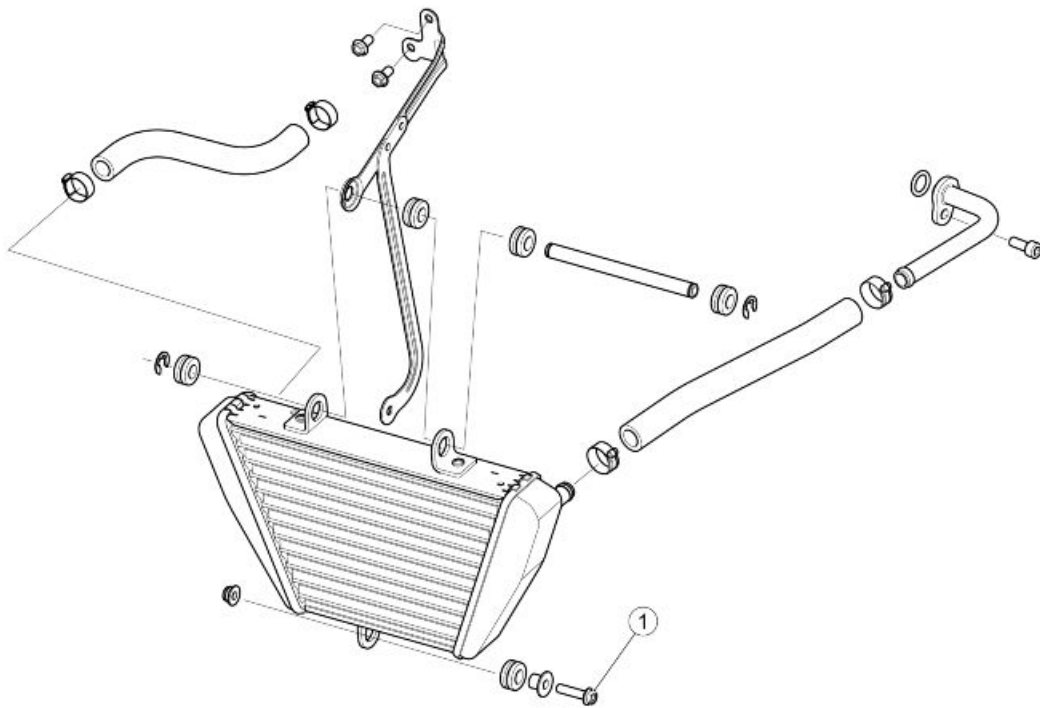

OIL RADIATOR

pos.	Description	Type	Quantity	Torque	Notes
1	Screws fastening oil radiator to mounting bracket	M6	1	7 Nm (5.16 lb ft)	-

(OHLINS FORKS)

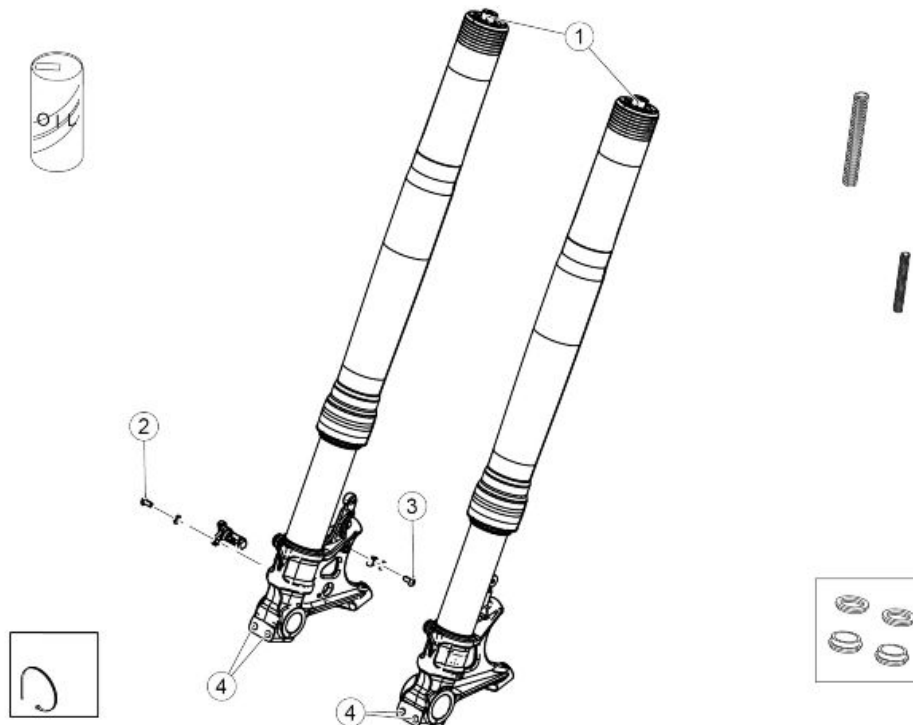

FRONT FORKS - OHLINS

Pos.	Description	Type	Quantity	Torque	Notes
1	Calliper bracket fixing screws (Oh-lins)	M6	2 + 2	12 Nm (8.85 lb ft)	-
2	Speed sensor fastening screw	M5	1	6 Nm (4.43 lb ft)	-
3	Cable gland fastening screw	M5	1	8 Nm (5.90 lb ft)	-

(SACHS FORKS)

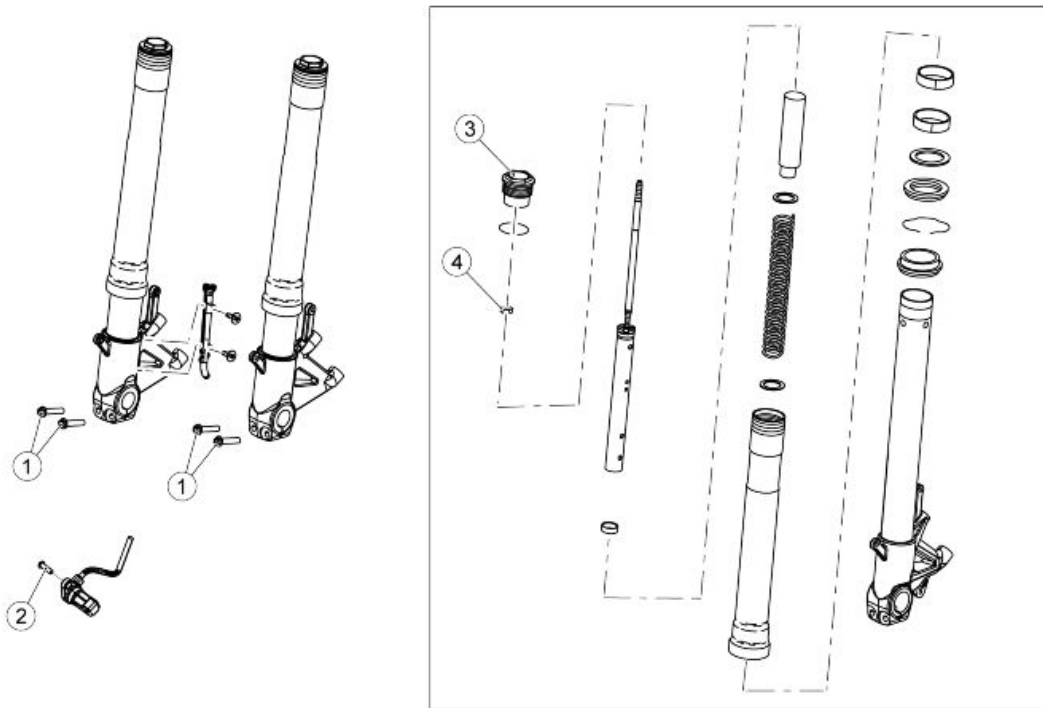

FRONT FORKS - SACHS

Pos.	Description	Type	Quantity	Torque	Notes
1	Calliper bracket fixing screws (Sachs)	M6	4	12 Nm (8.85 lb ft)	-
2	Speed sensor fastening screw	M5	1	6 Nm (4.43 lb ft)	-
3	Upper cap	-	2	20 Nm (14.75 lb ft)	-
4	Upper cap locking nut	-	2	20 Nm (14.75 lb ft)	-

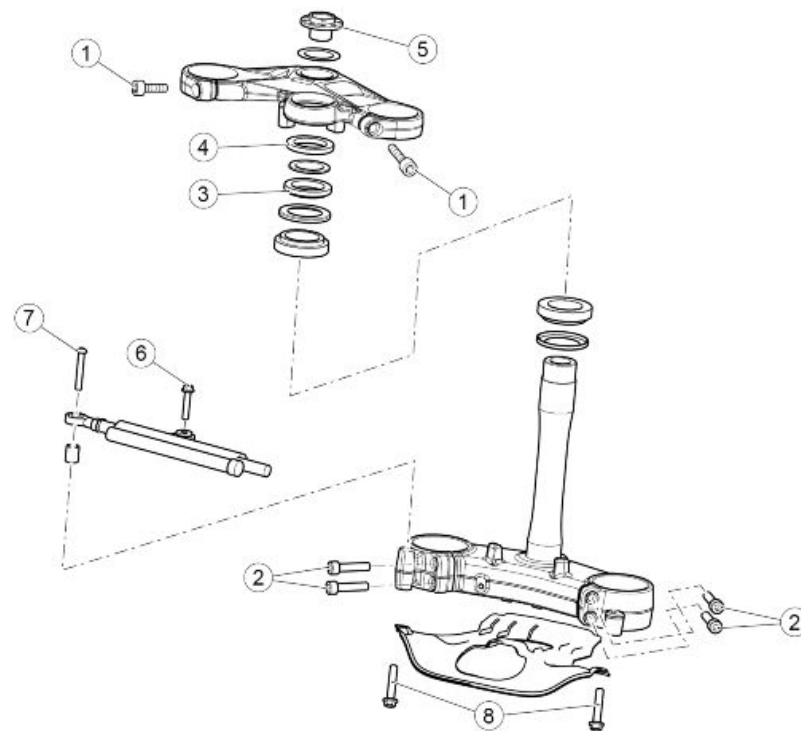

STEERING

pos.	Description	Type	Quantity	Torque	Notes
1	Screws fastening upper yoke to stanchions	M8	2	25 Nm (18.44 lb ft)	-
2	Screws fastening lower yoke to stanchions	M8	4	25 Nm (18.44 lb ft)	-
3	Headstock ring nut - pre-tightening	M35x1	1	70 Nm (51.63 lb ft)	Unscrew after pre-tightening
3	Headstock ring nut - tightening	M35x1	1	60 +/- 9 Nm (44.25 +/- 6.64 lb ft)	-
4	Headstock counter-lock ring	M35x1	1	Manual +35° or -10°	Bend the tabs into the notches in the lock ring
5	Upper yoke fixing cap	M29x1	1	100 Nm (73.76 lb ft)	-
6	Screw fastening shock absorber to frame	M6	1	10 Nm (7.38 lb ft)	Loctite 243
7	Screw fastening shock absorber to lower yoke	M6	1	10 Nm (7.38 lb ft)	Loctite 243
8	Lower cover fixing screws	M6	2	8 Nm (5.90 lb ft)	-

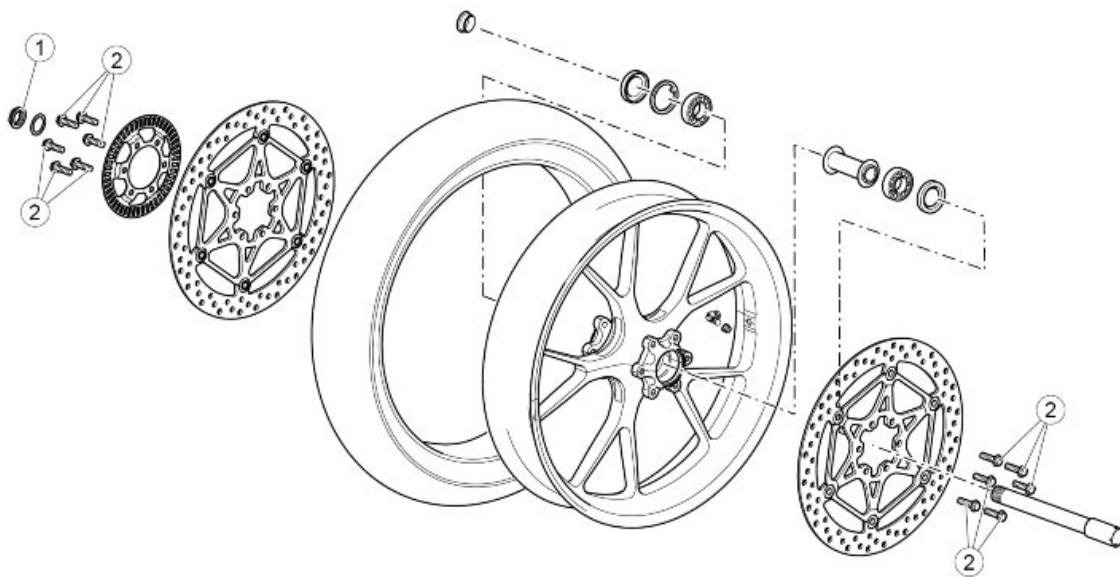

FRONT WHEEL

Pos.	Description	Type	Quantity	Torque	Notes
1	Front wheel pin nut	M25x1.5	1	80 Nm (59.00 lb ft)	-
2	Front brake disk fastening screws	M8	6 + 6	30 Nm (22.13 lb ft)	Loct. 243

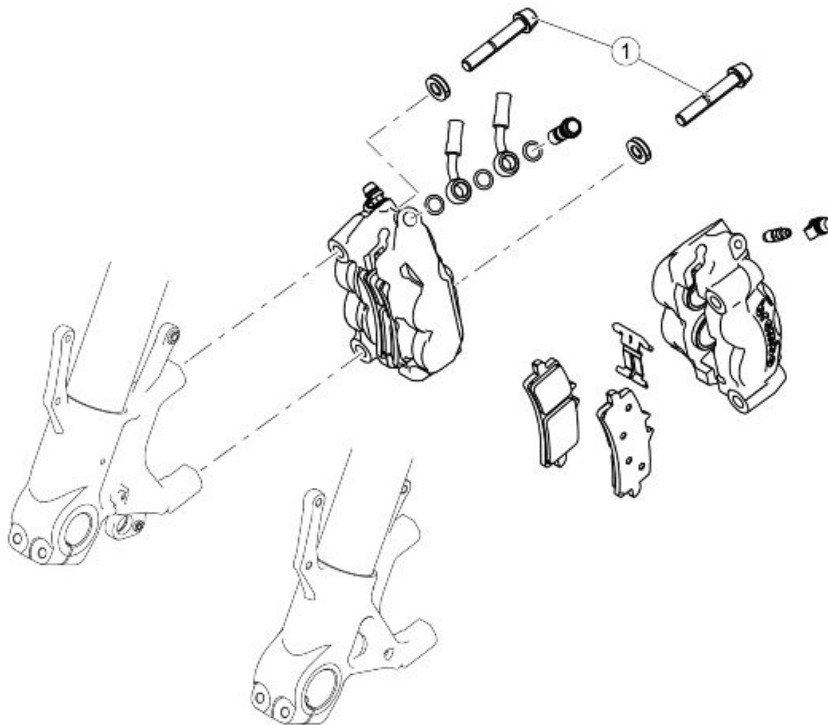

FRONT BRAKE CALLIPER

Pos.	Description	Type	Quantity	Torque	Notes
1	Front brake calliper fastening screws	M10x1.25	2 + 2	50 Nm (36.88 lb ft)	-

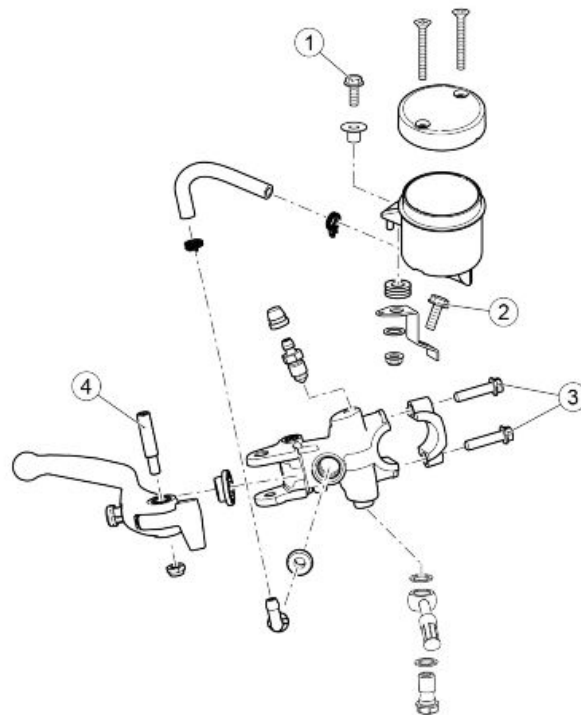
**FRONT BRAKE PUMP**

pos.	Description	Type	Quantity	Torque	Notes
1	Screw fastening front brake fluid reservoir to bracket	M6	1	7 Nm (5.16 lb ft)	-
2	Screw fastening brake fluid reservoir mounting bracket to handlebar	M6	1	7 Nm (5.16 lb ft)	-
3	Front brake pump U bolt clamp	M6	2	10 Nm (7.38 lb ft)	-
4	Front brake lever pin fixing screw	M6	1	10 Nm (7.38 lb ft)	-
-	Screw fastening brake pipe grommet to the lower yoke	M5	1	8 Nm (5.90 lb ft)	-

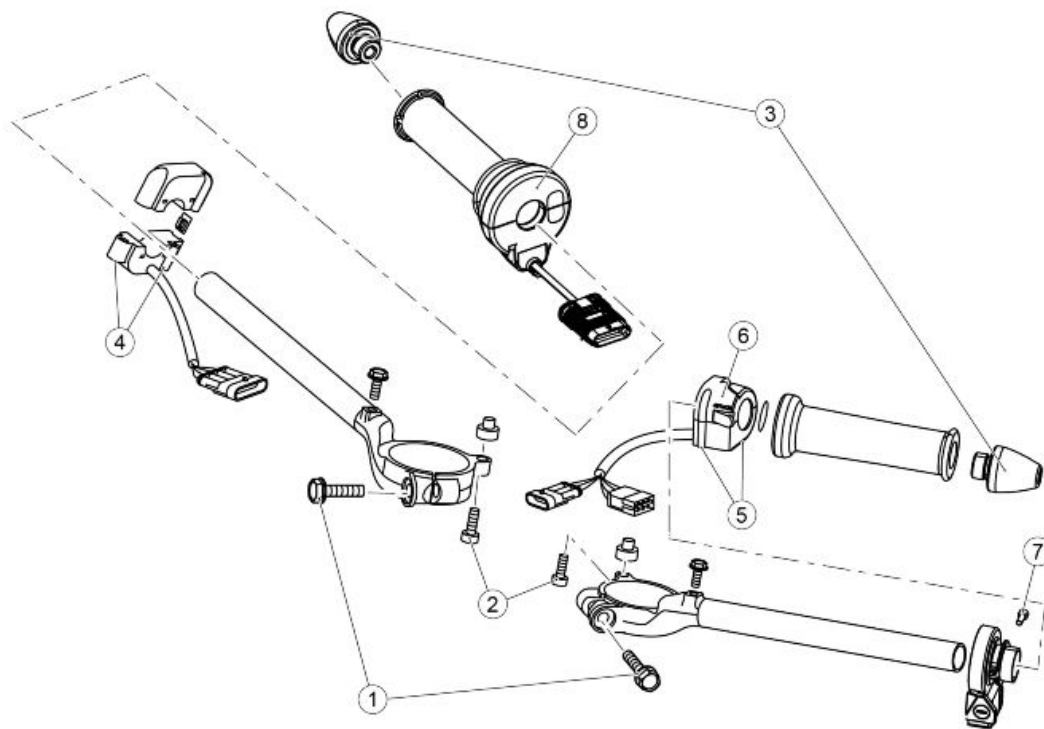

HANDLEBAR AND CONTROLS

Pos.	Description	Type	Quantity	Torque	Notes
1	Screws for fastening the handlebar collar to the forks sleeves	M8	1 + 1	25 Nm (18.44 lb ft)	-
2	Handlebar safety screw	M6	1+1	10 Nm (7.38 lb ft)	-
3	Anti-vibration counterweight fastener	M18x1.5	1+1	20 Nm (14.75 lb ft)	-
4	RH light switch	M5	2	1.5 Nm (1.11 lb ft)	-
5	LH light switch (outer shell)	M4	2	1.5 Nm (1.11 lb ft)	-
6	LH light switch (int. clamp)	M3	2	0.5 Nm (0.37 lb ft)	-
7	Traction control command fastening screw	M4	1	2.5 Nm (1.84 lb ft)	-
8	Screw for fastening the Ride-By-Wire control to the semi-handlebar	M4	1	2,2 Nm (1.62 lb ft)	-

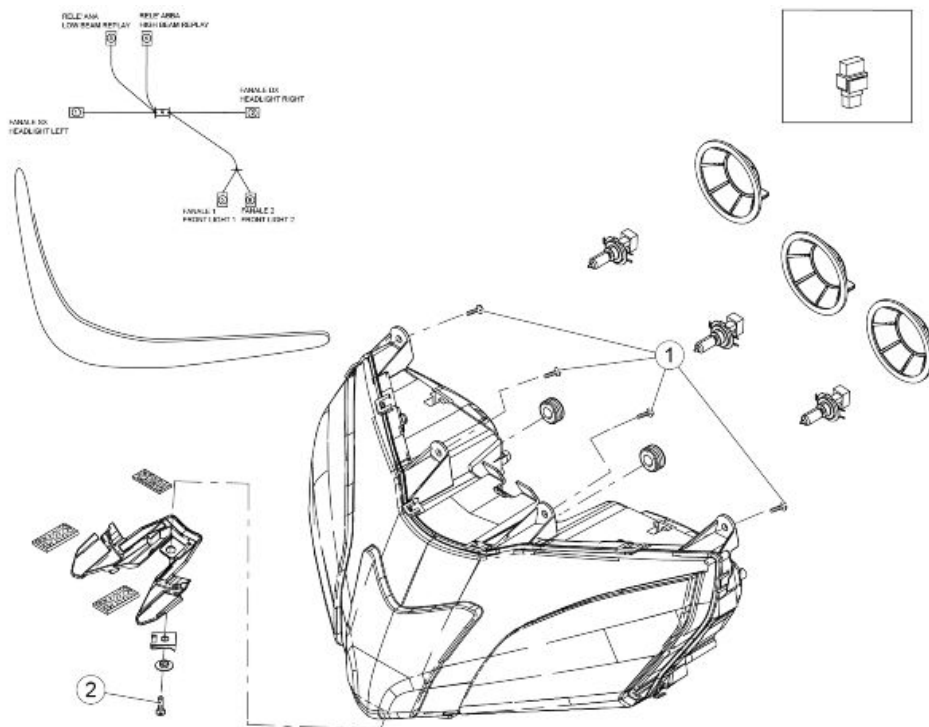

HEADLAMP

Pos.	Description	Type	Quantity	Torque	Notes
1	Screw for fastening the front headlight to the front mudguard	SWP 4.9	4	2 Nm (1.48 lb ft)	-
2	Headlamp fastener screw	M5 x 12	1	2 Nm (1.48 lb ft)	-

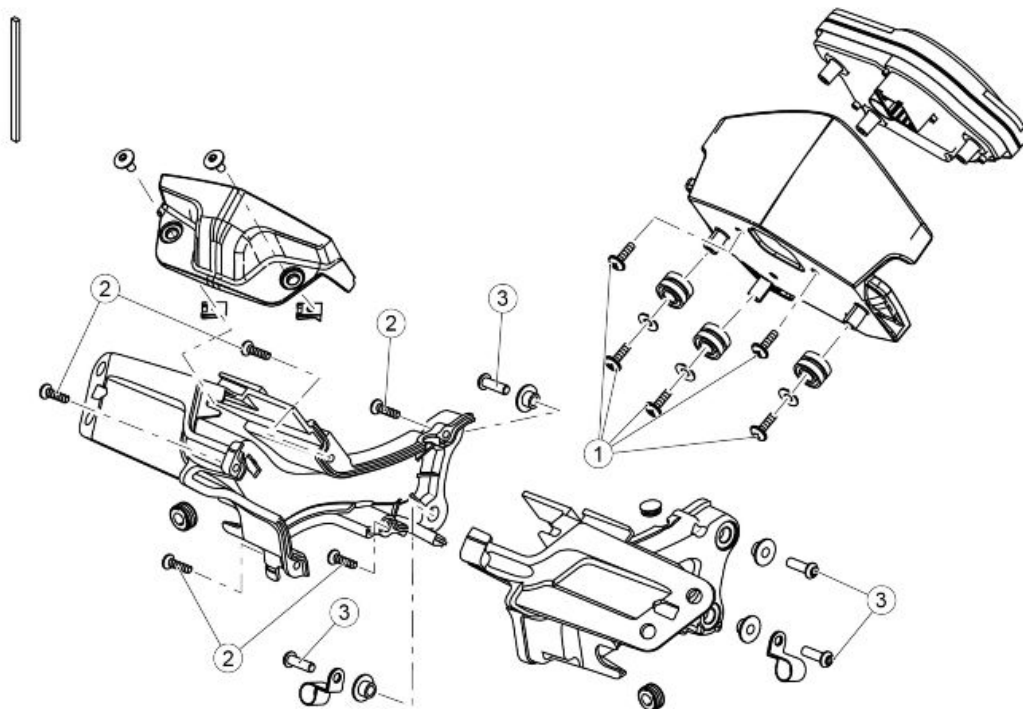

INSTRUMENT PANEL

Pos.	Description	Type	Quantity	Torque	Notes
1	Screws used to fasten the rubber blocks to the instrument panel	SWP 4.9	3	3 Nm (2.21 lb ft)	-
2	Instrument panel support shell fastening screws	SWP 4.9	5	2 Nm (1.48 lb ft)	-
3	Screws used to fasten the instrument panel support to the chassis	M6	4	8 Nm (5.90 lb ft)	-

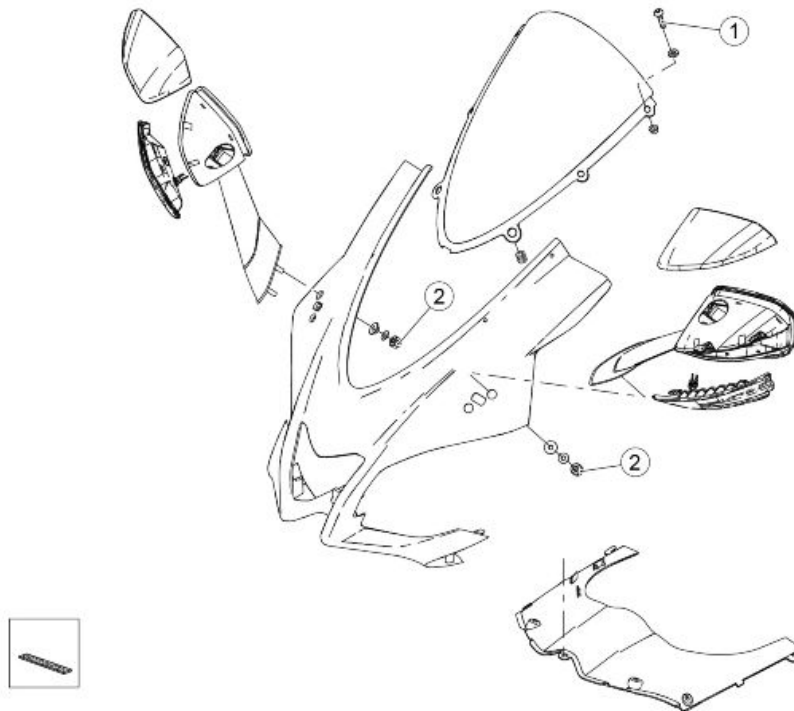

TOP FAIRING

pos.	Description	Type	Quantity	Torque	Notes
1	Windshield fixing screws	M4	4	0.5 Nm (0.37 lb ft)	-
2	Rear-view mirror fixing nuts	M6	2 + 2	10 Nm (7.38 lb ft)	-

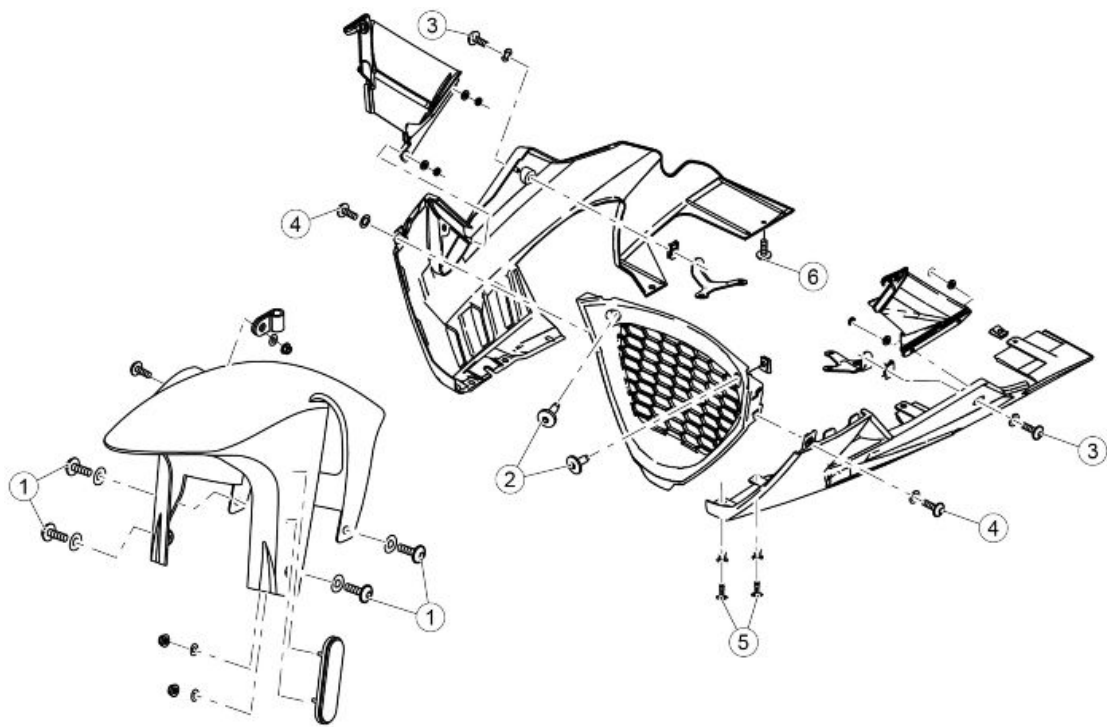

FRONT MUDGUARD

pos.	Description	Type	Quantity	Torque	Notes
1	Front mudguard fixing screws	M5	4	3 Nm (2.21 lb ft)	-
2	Lug fixing screws	M5	2	4 Nm (2.95 lb ft)	-
3	Screws fixing the side fairings to the side spacers	M5	2	1.5 Nm (1.11 lb ft)	-
4	Screws fastening the lower fairing to the lug	M5	2	2 Nm (1.48 lb ft)	-
5	Lower fairing lower fastening screws	M5	2	2 Nm (1.48 lb ft)	-
6	Centre screws fastening lower fairing	M6	2	10 Nm (7.38 lb ft)	-

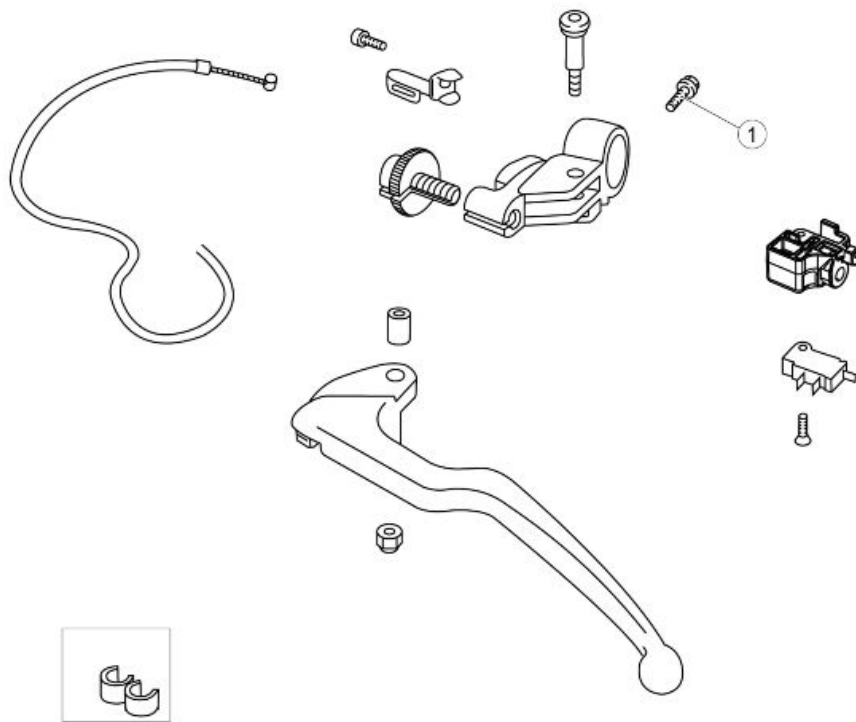

CLUTCH LEVER

Pos.	Description	Type	Quantity	Torque	Notes
1	Clutch lever collar fastening screws	M6	1	10 Nm (7.38 lb ft)	-

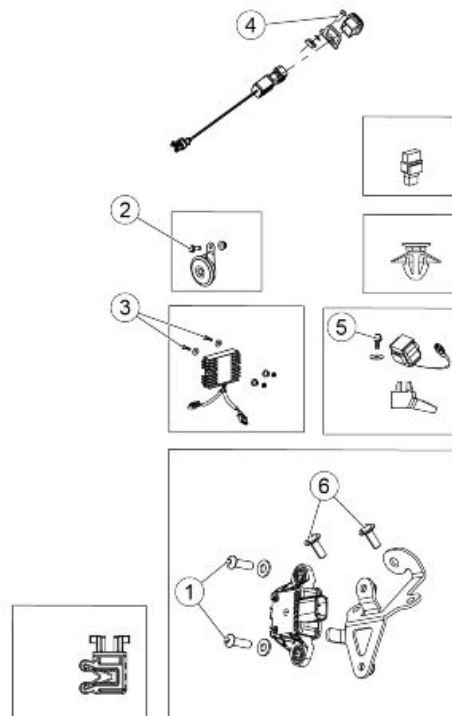

FRONT ELECTRICAL SYSTEM

Pos.	Description	Type	Quantity	Torque	Notes
1	Flanged button head hex socket screws for fastening the sensor to the bracket	M6x12	2	6 Nm (4.43 lb ft)	-

Pos.	Description	Type	Quantity	Torque	Notes
2	Horn fixing screw	M8	1	15 Nm (11.06 lb ft)	-
3	Button head, hex. socket voltage regulator fixing screws	M6x30	2	6 Nm (4.43 lb ft)	-
4	Button head, hex socket screws for fastening the USB port bracket (if fitted)	-	1	6 Nm (4.43 lb ft)	-
5	Flanged button head hex socket screws for fastening the sensor to the bracket	M6x12	2	6 Nm (4.43 lb ft)	-

Central part

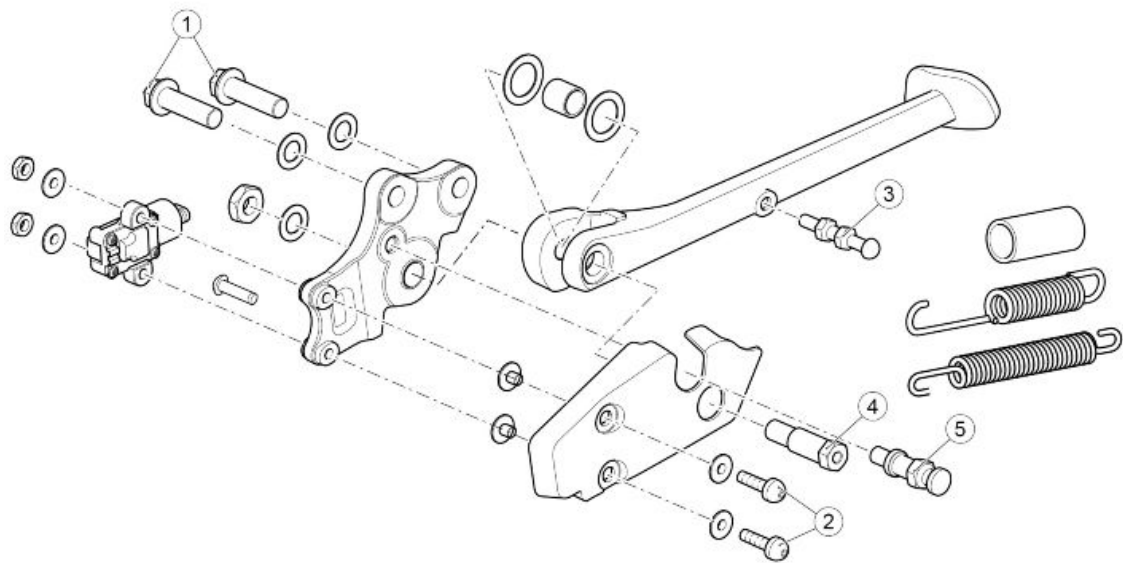

SIDE STAND

Pos.	Description	Type	Quantity	Torque	Notes
1	Screws for fastening the stand to the frame	M10	2	45 Nm (33.19 lb ft)	Loct. 243
2	Linear switch retaining screws and nuts	M5	2	4 Nm (2.95 lb ft)	-
3	- Spring retaining pin on stand	-	1	10 Nm (7.38 lb ft)	Loct. 243
4	Stand fastening pin	-	1	15 Nm (11.06 lb ft)	Loct. 243
5	Pin for retaining springs on stand pin	-	1	22 Nm (16.23 lb ft)	Loct. 243
-	Rear stand bushing retaining screw	M6	2	7 Nm (5.16 lb ft)	-

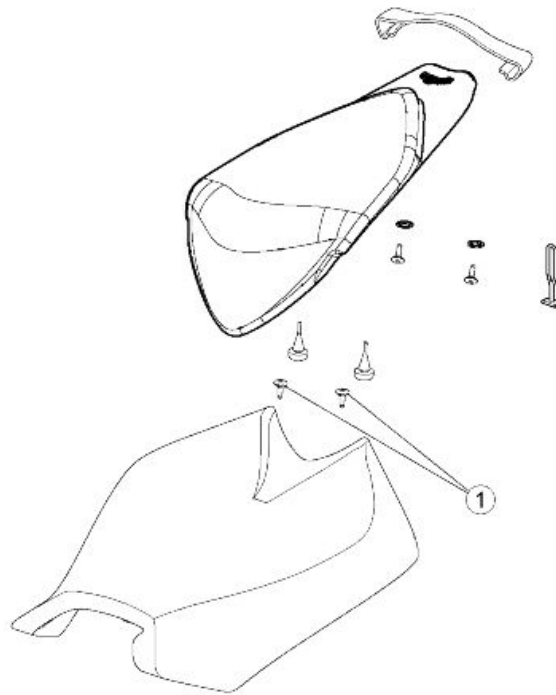

SADDLE

Pos.	Description	Type	Quantity	Torque	Notes
1	Rider's saddle retaining screw	M5	2	6 Nm (4.43 lb ft)	-
2	Passenger's saddle retaining pin fastening screw	M4	1	1.5 Nm (1.11 lb ft)	-

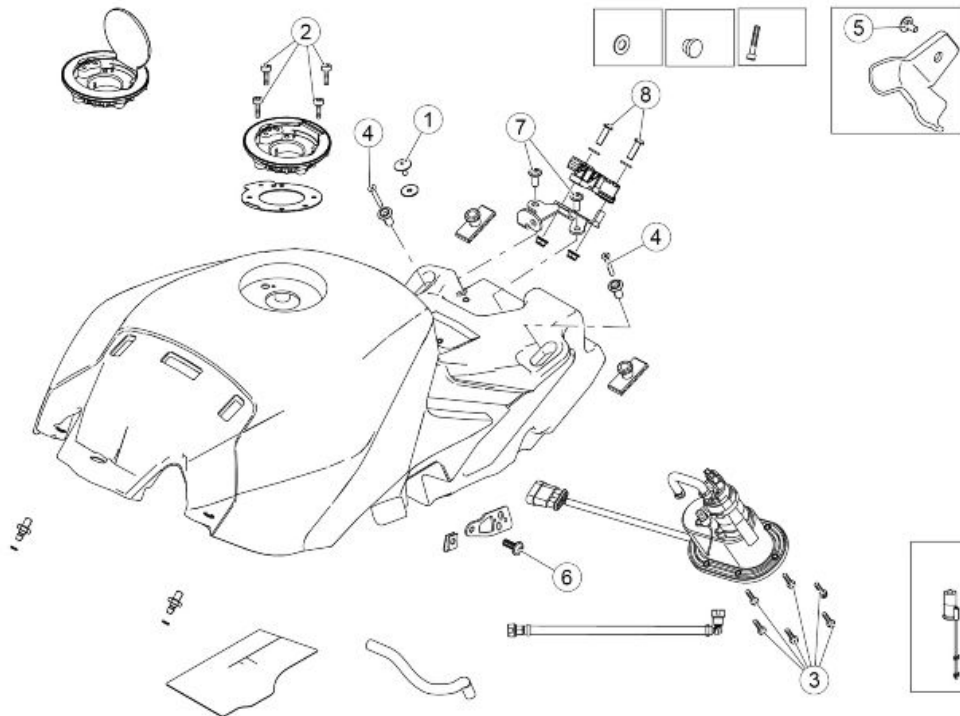

FUEL TANK

Pos.	Description	Type	Quantity	Torque	Notes
1	Special screw for fastening the rider's saddle to the fuel tank	M6	1	4 Nm (2.95 lb ft)	-
2	Filler to tank retaining screws	M5	4	4 Nm (2.95 lb ft)	-
3	Screws fastening fuel pump flange to fuel tank	M5	8	5 Nm (3.69 lb ft)	-
4	Screws fastening the rear fuel tank to the rear frame	M6	2	7 Nm (5.16 lb ft)	-
5	Plastic petrol hose support retaining screws	M5	1	2.5 Nm (1.84 lb ft)	-
6	LH fairing support bracket retaining screws	M5	1	3 Nm (2.21 lb ft)	-
7	Button head hex socket screws for fastening the sensor support to the fuel tank	M6x20	2	6 Nm (4.43 lb ft)	-
8	Flanged button head hex socket screws for fastening the sensor to the bracket	M6x12	2	6 Nm (4.43 lb ft)	-
-	Central fuel tank cover retaining screw	M4	1	0,5 Nm (0.37 lb ft)	-
-	Fuel tank breather couplings	M7	2	3 Nm (2.21 lb ft)	-
-	Fuel return coupling	M6	1	6 Nm (4.43 lb ft)	Loctite 243
-	Pump support to flange fastening	M5	3	4 Nm (2.95 lb ft)	-
-	Lug to flange fastening	M5	2	5 Nm (3.69 lb ft)	-
-	Petrol return closure	M6	1	10 Nm (7.38 lb ft)	Loctite 243
-	Petrol delivery pipe	M12x1.5	1	22 Nm (16.23 lb ft)	-
-	Petrol level sensor on pump support	SWP 2.9x12	2	1 Nm (0.74 lb ft)	-
-	Petrol pump on flange wiring	M6	2	10 Nm (7.34 lb ft)	-

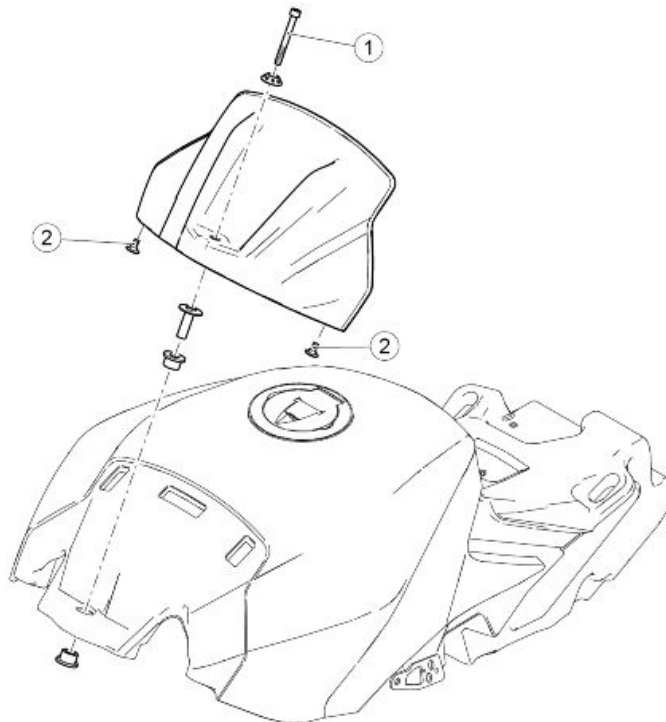
**FUEL TANK COVER**

Pos.	Description	Type	Quantity	Torque	Notes
1	Screws fastening front tank to frame	M6	1	8 Nm (5.90 lb ft)	-
2	Screws fastening tank structural support to tank	M6	4	3 Nm (2.21 lb ft)	-

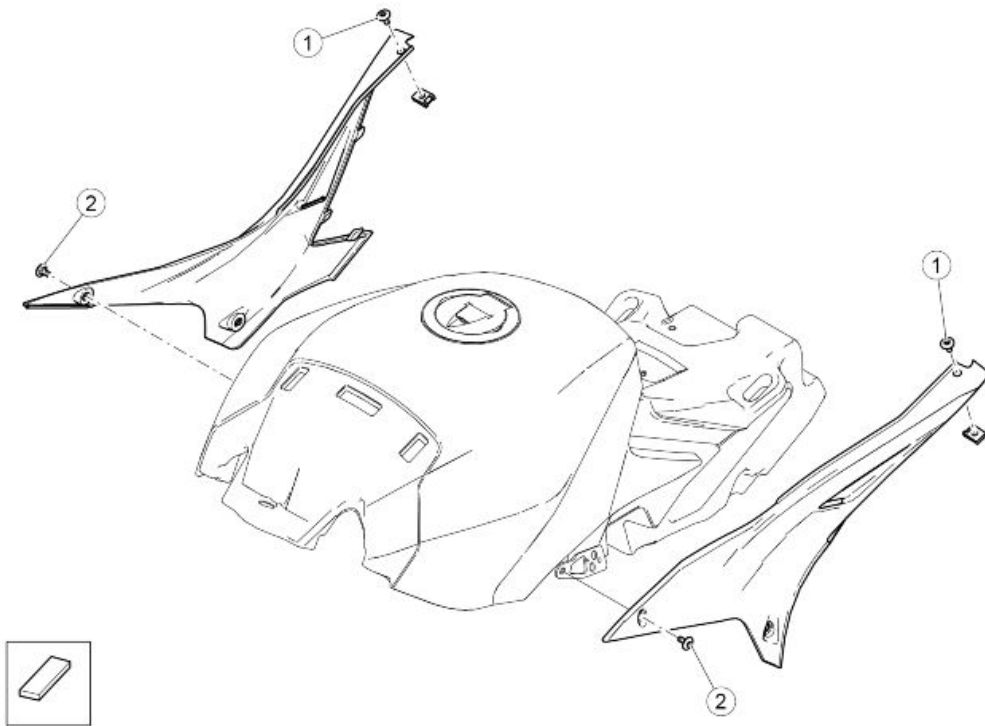

CENTRAL BODYWORK

Pos.	Description	Type	Quantity	Torque	Notes
1	Screws fastening fairing to tail fairing	M5	2	1 Nm (0.74 lb ft)	-
2	Screws fastening fairing to tank	M5	2 + 2	2 Nm (1.48 lb ft)	-

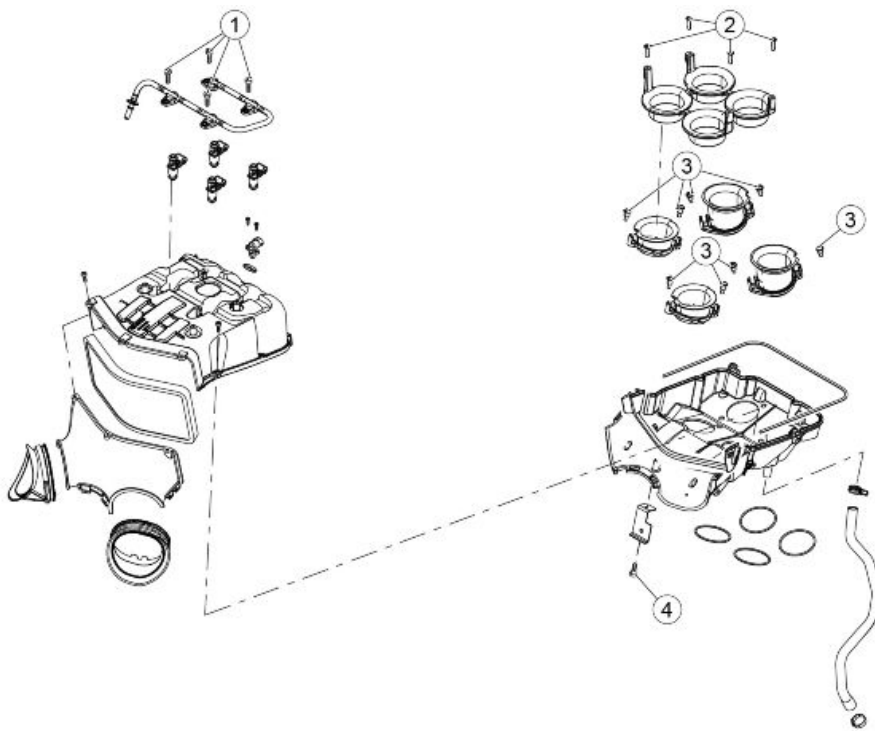

FILTER BOX

Pos.	Description	Type	Quantity	Torque	Notes
1	Flanged SWP petrol/injectors circuit fastening screws	M5x20	4	... Nm (... lb ft)	-
2	Flanged SWP upper intake ducts retaining screws	M5x20	4	... Nm (... lb ft)	-
3	Flanged SWP lower intake ducts retaining screws	-	4	... Nm (... lb ft)	-

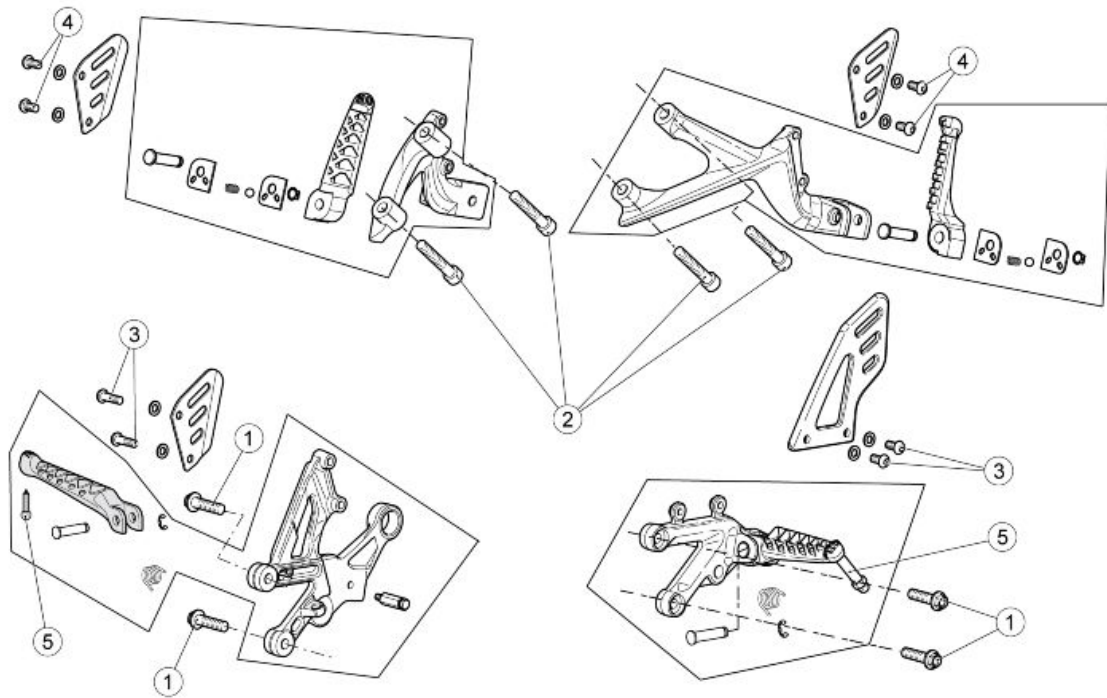

FOOTRESTS

Pos.	Description	Type	Quantity	Torque	Notes
1	Screws for fastening the rider's footrests to the frame	M8	2 + 2	25 Nm (18.44 lb ft)	Loctite 243
2	Screws for fastening the passenger's footrests to the frame	M8	2 + 2	18 Nm (13.28 lb ft)	Loctite 243 - For use in countries where it is mandatory to fit the passenger's footrests or for the two-seater configuration
3	Rider's heel guard retaining screws	M6	2 + 2	8 Nm (5.90 lb ft)	-
4	Passenger's heel guard retaining screws	M6	2 + 2	8 Nm (5.90 lb ft)	-
5	Anti-creep pin	M6	1	8 Nm (5.90 lb ft)	-

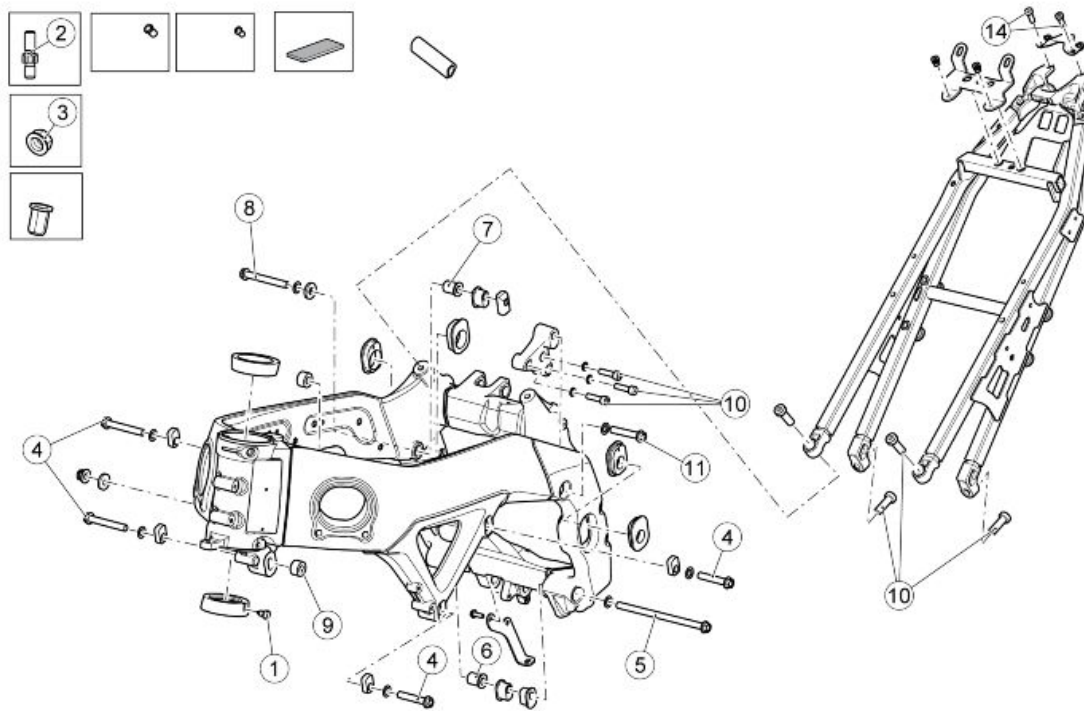

CHASSIS

pos.	Description	Type	Quantity	Torque	Notes
1	Headstock locator dowel	M8x1	2	10 Nm (7.37 lb ft)	-
2	Threaded intake duct fastener pins	M6	2 + 2	4 Nm (2.95 lb ft)	Loct. 243
3	Intake duct fixing nuts	M6	2 + 2	Manual	-
4	Front couplings	M10	2 + 2	50 Nm (36.88 lb ft)	-
5	Lower rear coupling	M10	1	50 Nm (36.88 lb ft)	-
6	RH lower rear regulator bushing	M18x1.5	1	12 Nm (8.85 lb ft)	-
7	RH upper rear regulator bushing	M18x1.5	1	12 Nm (8.85 lb ft)	-
8	RH upper rear coupling	M10	1	50 Nm (36.88 lb ft)	-
9	Right fairing spacer	M6	1	10 Nm (7.37 lb ft)	Loct. 243
10	Upper rear left hand engine mount fastener screws	M8	3	25 Nm (18.44 lb ft)	-
11	Upper rear mount	M10	1	50 Nm (36.88 lb ft)	-
12	Saddle mounting fixing screws	M10	4	50 Nm (36.88 lb ft)	-
13	Passenger saddle and saddle cover catch plate fixing screws	M6	2	8 Nm (5.9 lb ft)	-
14	Taillight mounting bracket fixing screws	M5	2	4 Nm (2.95 lb ft)	-
-	Screw fastening the ground cable to the left side chassis	M6	1	6 Nm (4.42 lb ft)	-
-	Screws fastening oil radiator mounting bracket to engine	M6	2	8 Nm (5.9 lb ft)	-

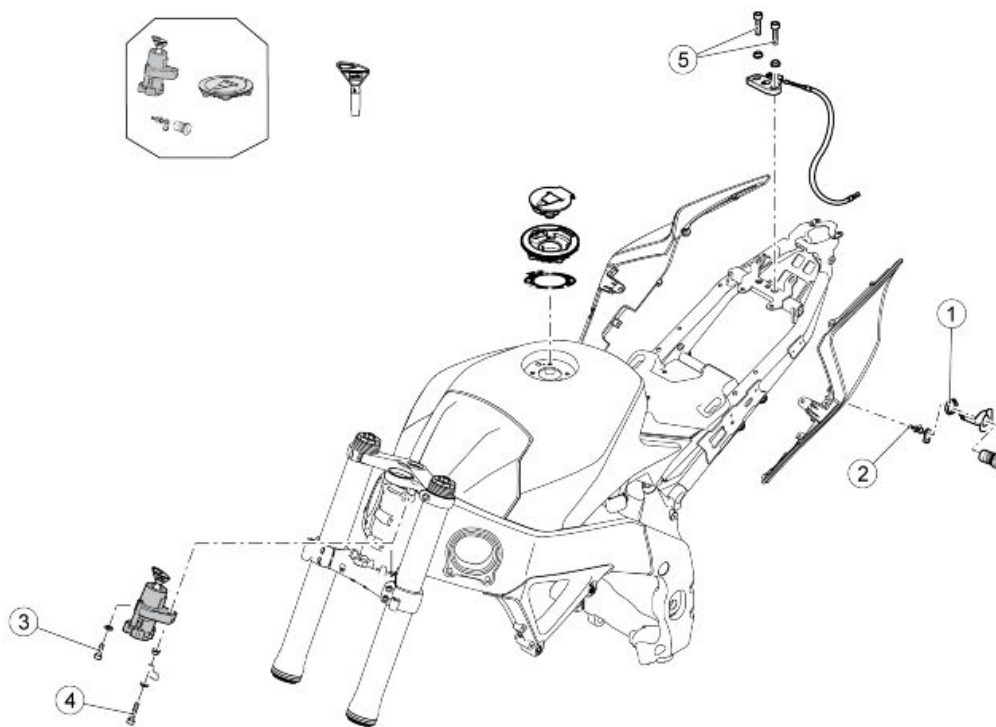

Locks

pos.	Description	Type	Quantity	Torque	Notes
1	Nut fastening saddle lock to tail fairing	M22x1.5	1	5 Nm (3.69 lb ft)	-
2	Lock lever self-tapping screw	M4	1	2 Nm (1.48 lb ft)	-
3	Shear head screw (to the left of the ignition lock)	M8	1	Manual	Tighten until the head shears off
4	Right hand ignition lock screw	M8	1	20 Nm (14.75 lb ft)	-
5	Passenger saddle fixing screws	M6	2	8 Nm (5.90 lb ft)	-

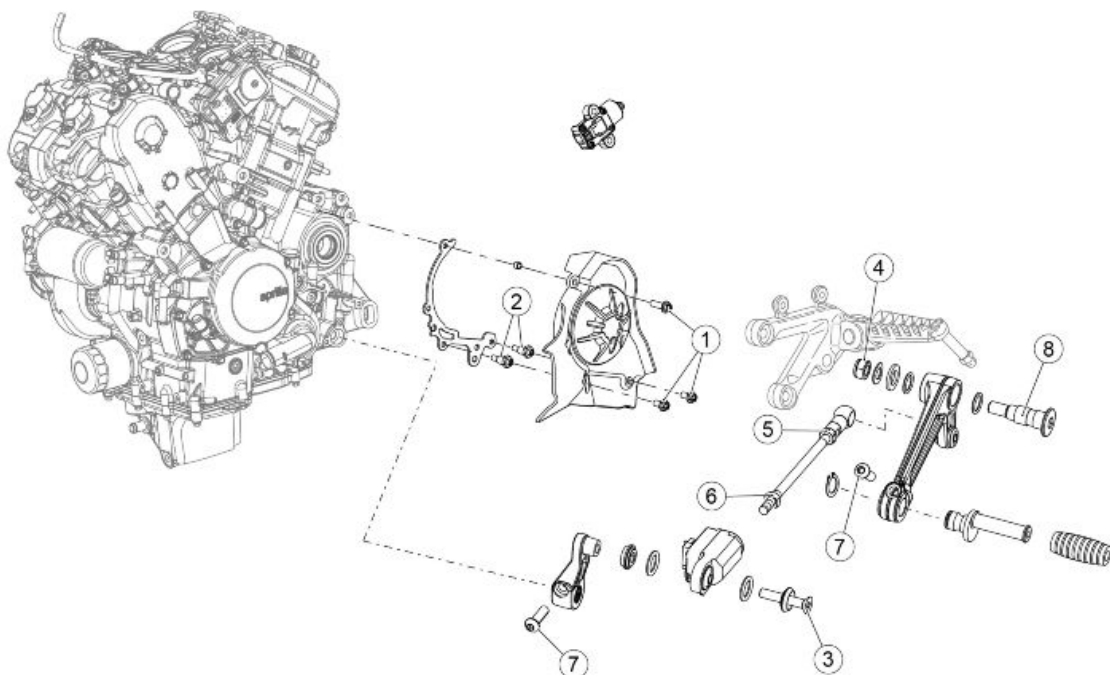

GEAR LEVER

Pos.	Description	Type	Quantity	Torque	Notes
1	Pinion protection guard fastening screws	M6	3	6 Nm (4.43 lb ft)	-
2	Threaded spacer	-	2	8 Nm (5.90 lb ft)	-
3	Countersunk, flat head, hex. socket screws	M6x35	1	10 Nm (7.38 lb ft)	Loct.
4	Self-locking nut	M8	1	25 Nm (18.44 lb ft)	-
5	Fastening between gear change tie-rod joint and gear change lever	-	1	8 Nm (5.90 lb ft)	Loct.
6	Nut used to fasten the gearbox tie-rod to the quick shift device	-	1	8 Nm (5.90 lb ft)	-
7	Gearbox lever fixing screws	M6	2	8 Nm (5.90 lb ft)	-
8	Pin for fastening the gear change lever to the footrest support	M8	1	25 Nm (18.44 lb ft)	-

- Apply water-repellent grease between the O-rings and the Quick Shift uniball

NOTE

ONCE ASSEMBLE, THE DISTANCE BETWEEN THE UNIBALL AND THE JOINT MUST BE APPROXIMATELY 180mm (7.09in).

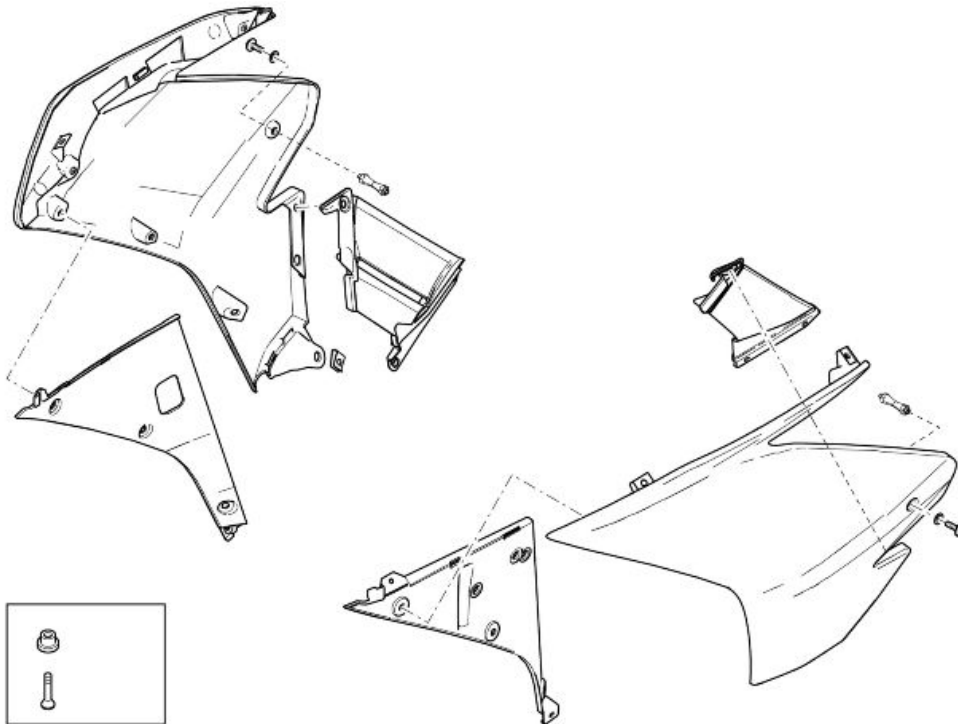

FAIRING

Pos.	Description	Type	Quantity	Torque	Notes
-	Fairing retaining spacer	M6	2	8 Nm (5.90 lb ft)	-
-	Lower fairing central bracket fastening screws	M6	2	10 Nm (7.38 lb ft)	-
-	RH lower fairing support bracket	M6	2	12 Nm (8.85 lb ft)	-
-	LH lower fairing support bracket	M6	2	12 Nm (8.85 lb ft)	-
-	Screws for fastening the side fairings to the lateral spacers	M5	2	1.5 Nm (1.11 lb ft)	-
-	Screws for securing the upper fairing closure to the intake duct	M5	2	1.5 Nm (1.11 lb ft)	-
-	Screws for securing the upper fairing closure to the front mudguard	M5	2	1.5 Nm (1.11 lb ft)	-
-	Screws for securing the upper fairing closure to the intake duct	self-tapping	2	1 Nm (0.74 lb ft)	-

Pos.	Description	Type	Quantity	Torque	Notes
-	Screws for securing the upper fairing closure to the front headlight	self-tapping	2	1 Nm (0.74 lb ft)	-
-	Screws for fastening the lower fairing to the bracket	M5	2 + 2	1 Nm (0.74 lb ft)	-
-	Screws for fastening the lower fairing to the stanchion	M5	2	2 Nm (1.47 lb ft)	-
-	Lower fairing fastening screws	M5	2	2 Nm (1.47 lb ft)	-
-	Lower forks closure fastening screws	M6	2	8 Nm (5.90 lb ft)	-
-	Screws for fastening the lower frontal closure to the intake ducts	SWP 3,9	2	1 Nm (0.74 lb ft)	-
-	Internal fastening screws between the fairing and the lower frontal closure	M4	2	0,5 Nm (0.37 lb ft)	-
-	Internal fastening screws between the airing and the stanchion	M5	2	2 Nm (1.48 lb ft)	-

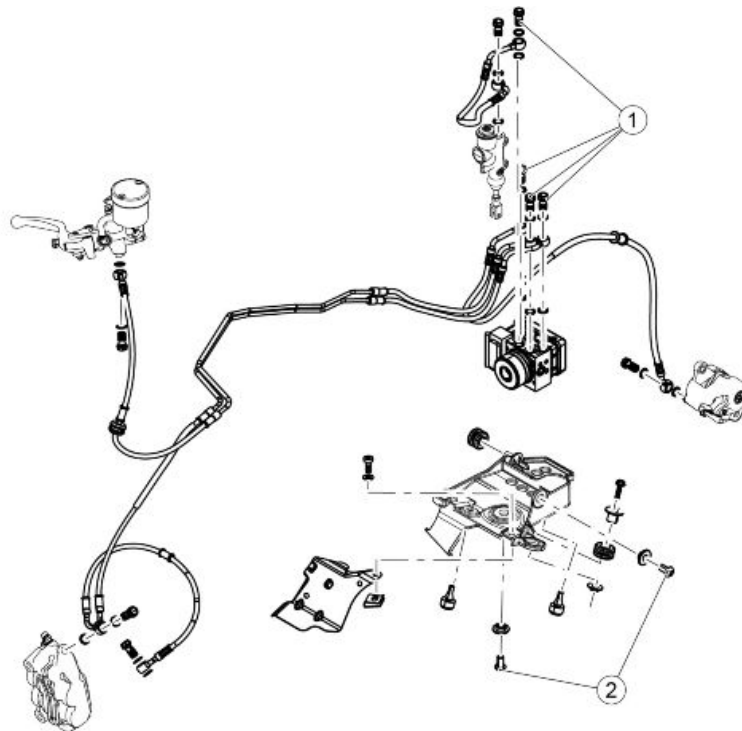

ABS CONTROL UNIT

Pos.	Description	Type	Quantity	Torque	Notes
1	Oil tube screws	M10x1	4	23-26 Nm (16.96-19.18 lb ft)	-
2	Control unit support screws	M6	2	6.8+/-1 Nm (5.01 +/-0.74 lb ft)	-

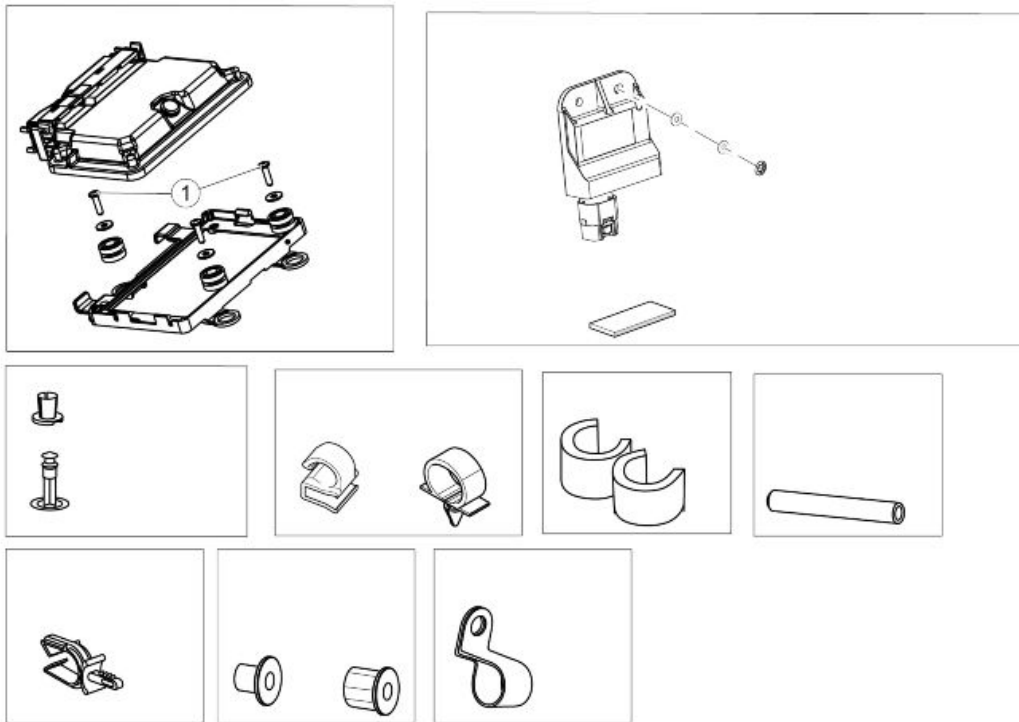

CENTRAL ELECTRICAL SYSTEM

Pos.	Description	Type	Quantity	Torque	Notes
-	Starter relay cables fastening screws	M5	2	4 Nm (2.95 lb ft)	-

Back side

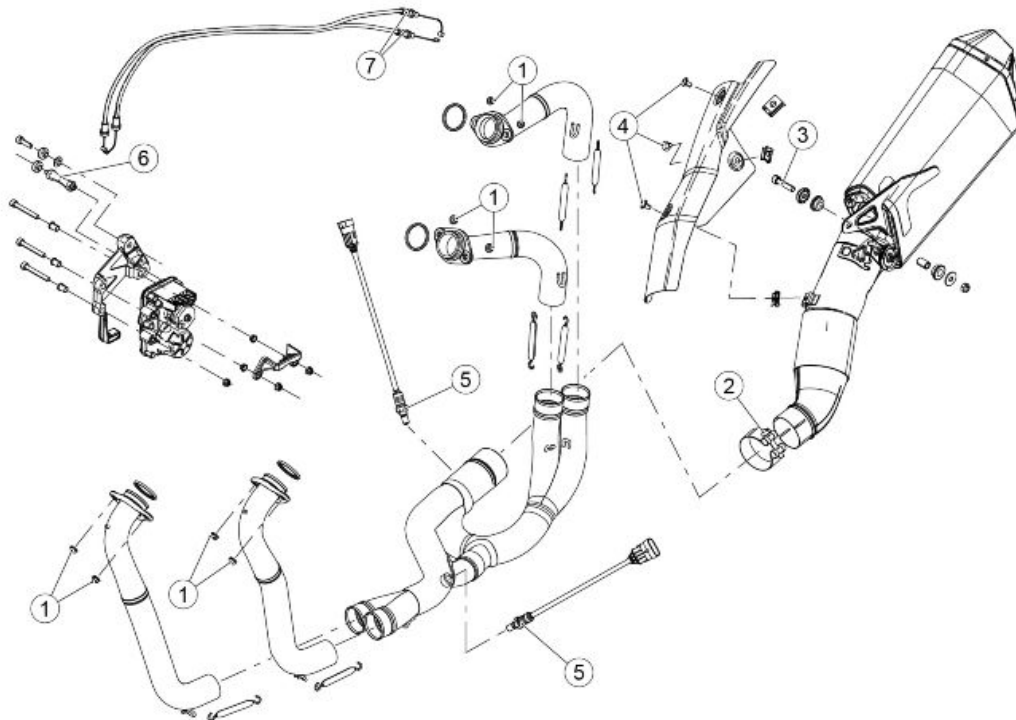

EXHAUST

Pos.	Description	Type	Quantity	Torque	Notes
1	Exhaust manifold flange fastening nuts	M7	8	13 Nm (9.59 lb ft)	-
2	Silencer clamp fastening screw - central manifold	M8	1	20 Nm (14.75 lb ft)	-
3	Screw used to secure the silencer to the RH footrest support	M8	1	25 Nm (18.44 lb ft)	-
4	Torx button head silencer aesthetic protection fastening screw	M6x10	3	8 Nm (5.90 lb ft)	-
5	Lambda probe fastener	-	2	18 Nm (13.28 lb ft)	-
6	RH fairing spacer	M6	1	8 Nm (5.90 lb ft)	-
7	Exhaust valve opening/closing cables regulator lock-nuts	M6	2	5 Nm (3.69 lb ft)	-

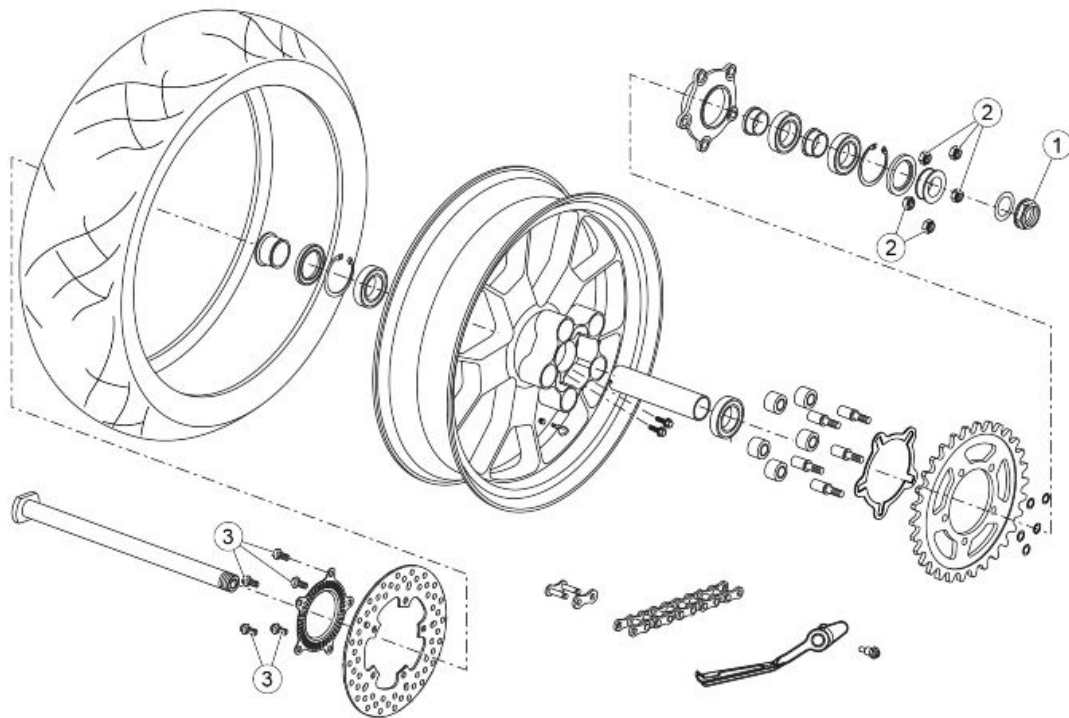

REAR WHEEL

Pos.	Description	Type	Quantity	Torque	Notes
1	Rear wheel axle nut	M25x1.5	1	120 Nm (88.51 lb ft)	-
2	Nuts for fastening crown to sprocket	M10	5	50 Nm (36.88 lb ft)	-
3	Rear brake disc fastening screws	M8	5	30 Nm (22.13 lb ft)	Loct. 243

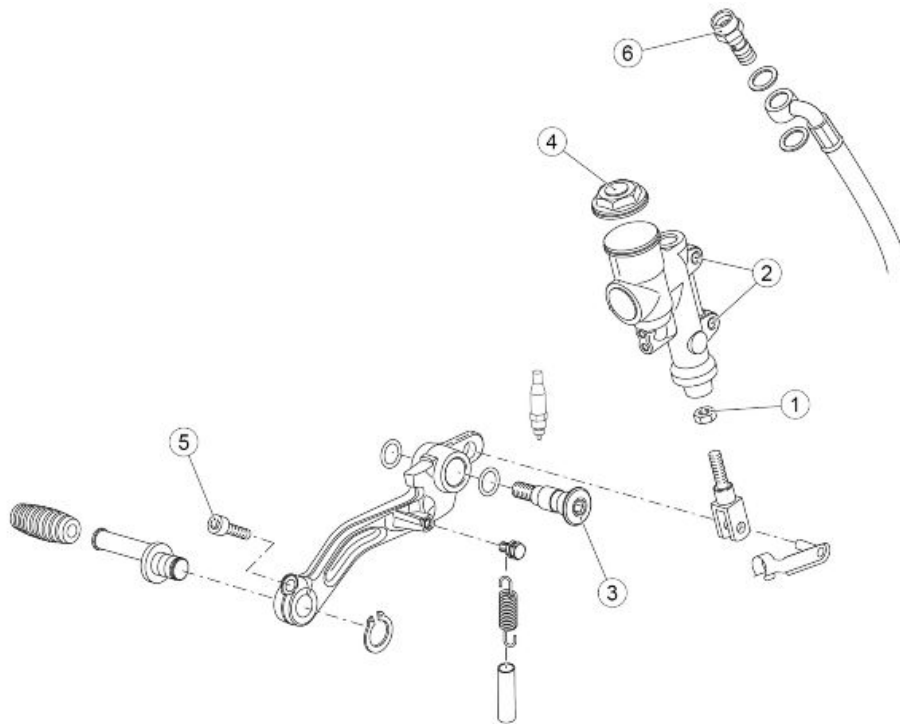

REAR BRAKE MASTER CYLINDER

Pos.	Description	Type	Quantity	Torque	Notes
1	Rear brake rod lock nut	M6	1	12 Nm (8.85 lb ft)	-
2	Rear brake pump retaining screws	M6	2	8 Nm (5.90 lb ft)	Loctite 243
3	Rear brake lever fixing pin	M8	1	25 Nm (18.44 lb ft)	Loctite 243
4	Tank filler cap	-	1	17-23 Nm (12.54-16.96 lb ft)	-
5	Brake lever ferrule retaining screw	M6	1	8 Nm (5.90 lb ft)	-
6	Special oil pipe coupling retaining screw	-	1	23-26 Nm (16.96-19.18 lb ft)	-

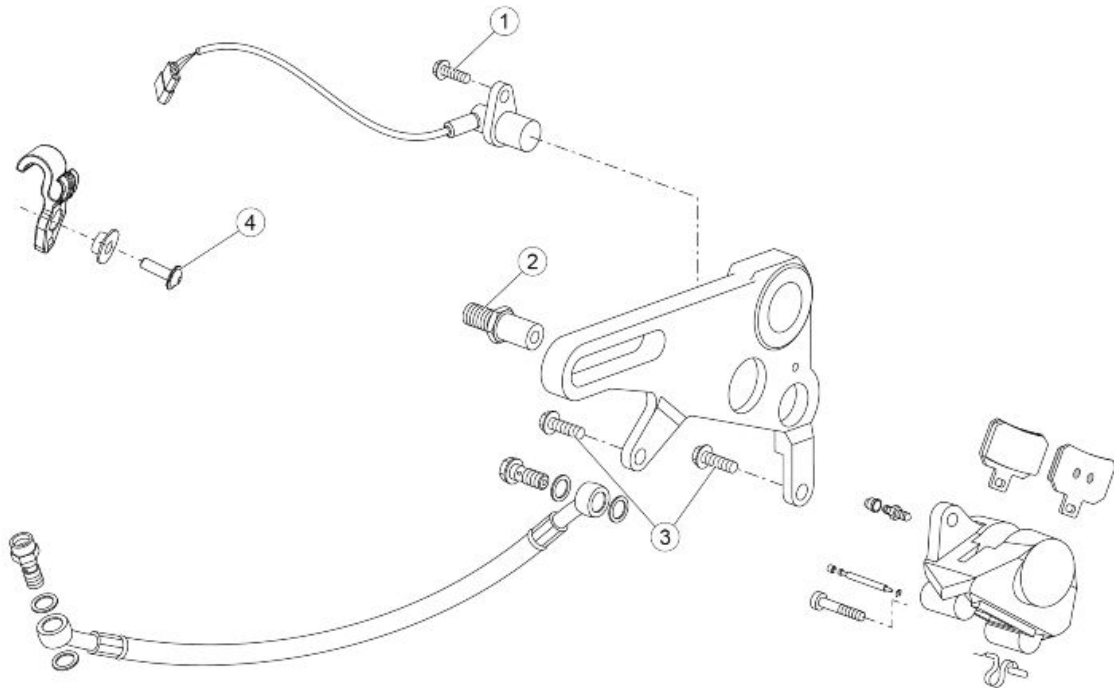

REAR BRAKE CALLIPER

Pos.	Description	Type	Quantity	Torque	Notes
1	ABS sensor fixing screw	M6	1	6 Nm (4.43 lb ft)	-
2	Rear brake calliper support plate retaining pin	M12	1	50 Nm (36.88 lb ft)	Loct. 243
3	Rear brake calliper fastening screw	M5	2	25 Nm (18.44 lb ft)	-
4	Brake pipe bracket fastening screw	M5	1	4 Nm (2.95 lb ft)	-
-	Screw fastening brake pipe clamp	M5	2	4 Nm (2.95 lb ft)	-

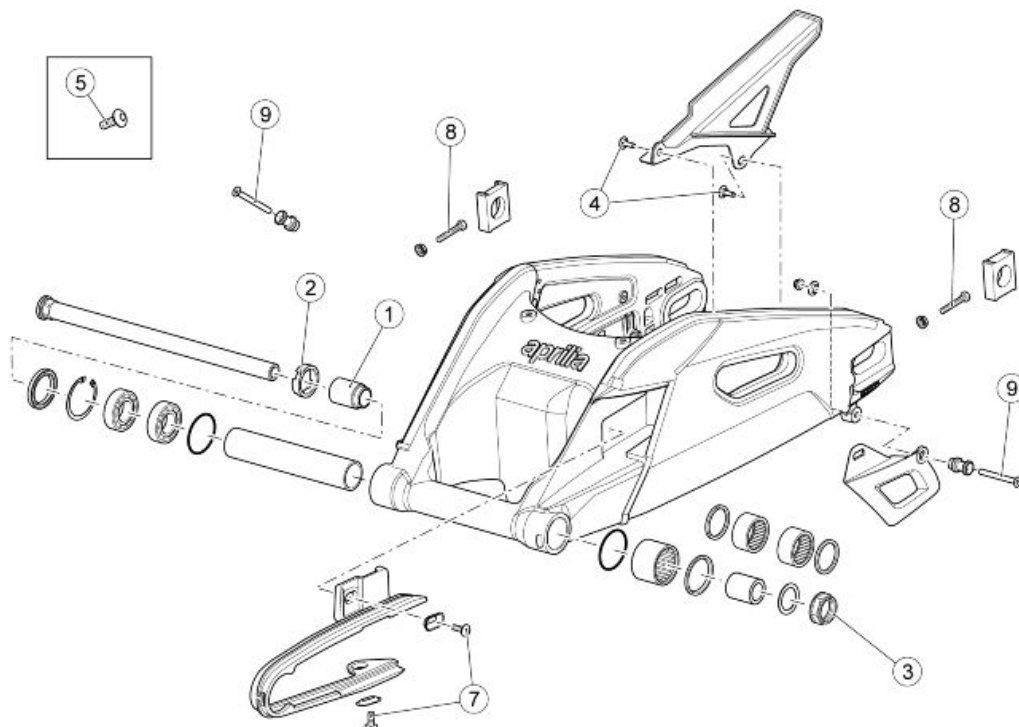

REAR SWINGARM

pos.	Description	Type	Quantity	Torque	Notes
1	Swingarm regulator bushing	M30x1.5	1	12 Nm (8.85 lb ft)	-
2	Swingarm ferrule	M30x1.5	1	60 Nm (44.25 lb ft)	-
3	Fork pin nut	M20x1.5	1	65 Nm (47.94 lb ft)	AGIP GREASE SM2
4	Chain guard fastening screws	M5	2	4 Nm (2.95 lb ft)	-
5	Front chain guide fixing screw	M5	1	4 Nm (2.95 lb ft)	-
6	Chain guide rear fastening nut	M6	1	7 Nm (5.16 lb ft)	-
7	Chain feeder shoe fastening screws	M5	2	2 Nm (1.48 lb ft)	-
8	Chain tensioner fastener screw	M8	2	Manual	-
9	Rear stand bushing fastening screws	M6	2	7 Nm (5.16 lb ft)	-
-	Lower chain shoe fastening screws	M6	2	10 Nm (7.38 lb ft)	-

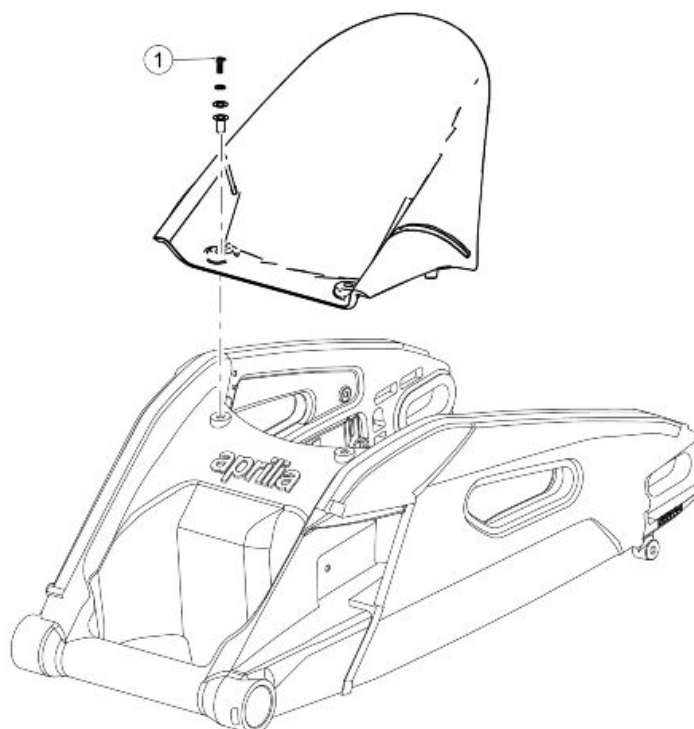

REAR MUDGUARD

pos.	Description	Type	Quantity	Torque	Notes
1	Rear mudguard fixing screws	M6	2	5 Nm (3.69 lb ft)	For plastic mud-guard
1	Rear mudguard fixing screws	M6	2	3 Nm (2.21 lb ft)	For carbon mud-guard

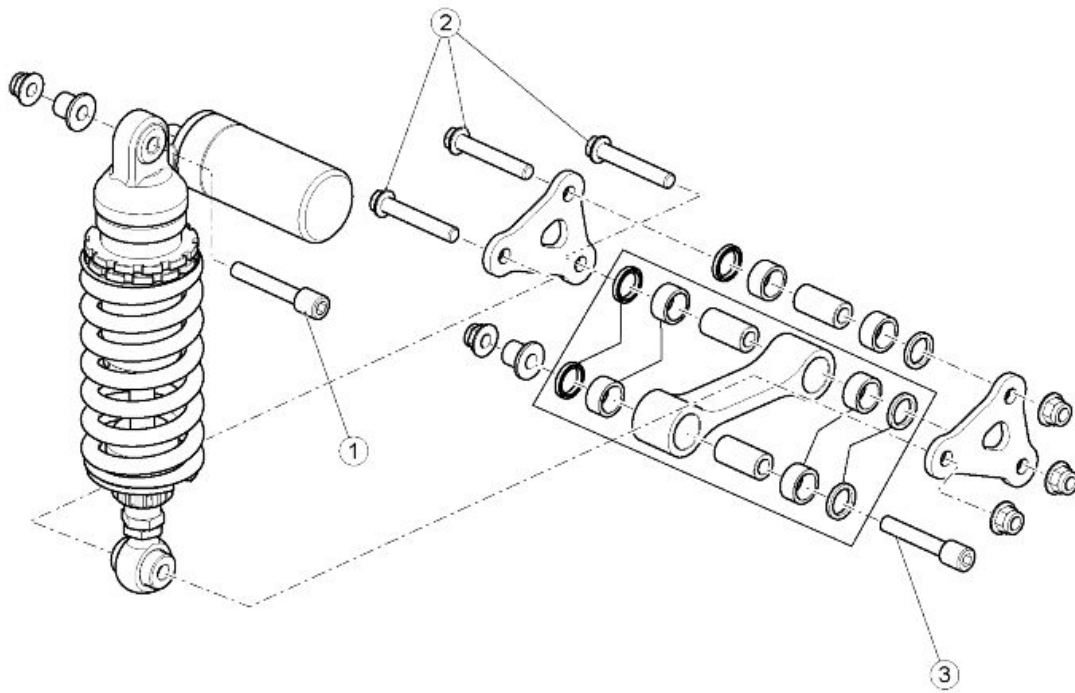

REAR SHOCK ABSORBER

pos.	Description	Type	Quantity	Torque	Notes
1	Upper shock absorber fixing screw	M10	1	50 Nm (36.88 lb ft)	-
2	Dual connecting rod fixing screw	M10	3	50 Nm (36.88 lb ft)	-
3	Screw fastening single connecting rod to chassis	M10	1	50 Nm (36.88 lb ft)	-

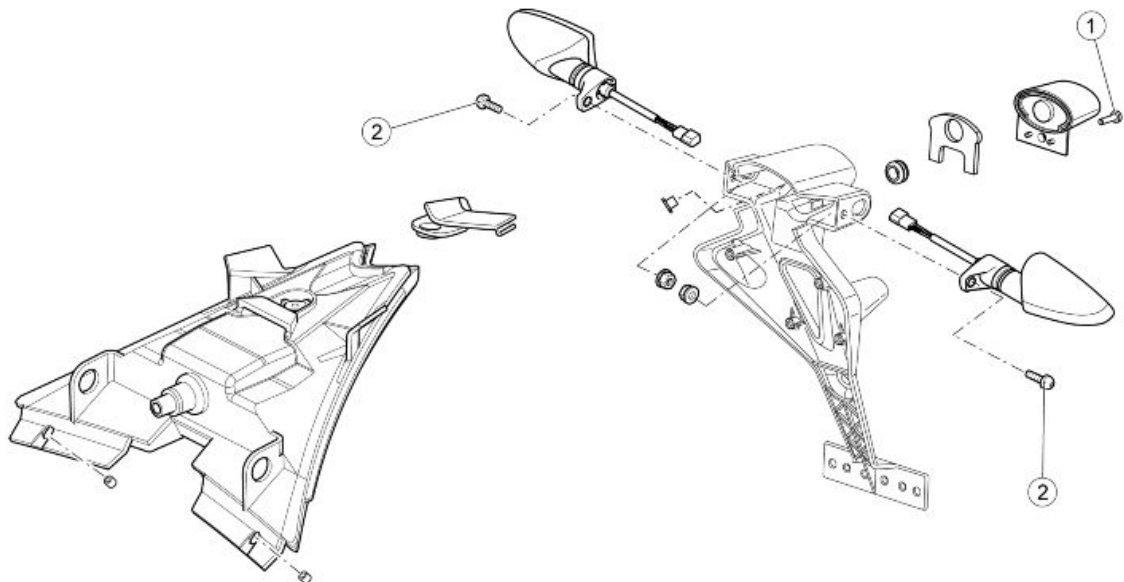

LICENSE PLATE HOLDER

pos.	Description	Type	Quantity	Torque	Notes
1	License plate light fixing screws	M4	1	1 Nm (0.74 lb ft)	-
2	Rear turn indicator fixing screws	M6	2	2.5 Nm (1.84 lb ft)	-
3	Taillight fixing screws	M5	2	3 Nm (2.21 lb ft)	-
4	Taillight cover self-tapping fixing screw	SWP 3.9	1	0.5 Nm (0.37 lb ft)	-
-	Screws fastening license plate mounting to saddle mounting casting	M6	3	4 Nm (2.95 lb ft)	-

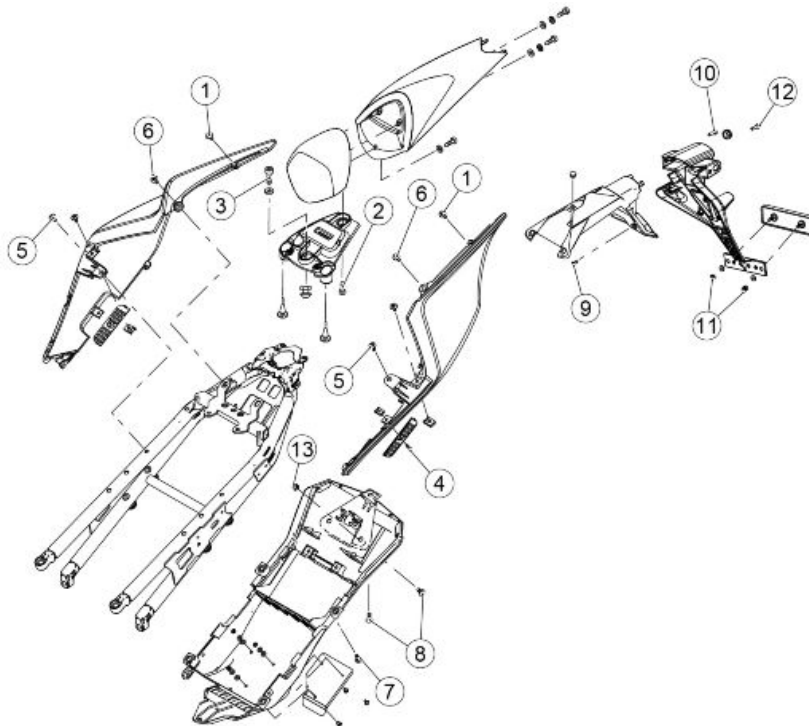

REAR BODYWORK

Pos.	Description	Type	Quantity	Torque	Notes
1	Rear screws used to fasten the tail fairing to the rear headlight bracket	M5	2	3 Nm (2.21 lb ft)	-
2	Screws used to fasten the saddle cover base to the saddle cover	SWP 2.9	3	1 Nm (0.74 lb ft)	-
3	Saddle cover stud fastening screws	M4	1	1.5 Nm (1.11 lb ft)	-
4	Screws used to fasten the grilles to the tail fairing	M5	2	0.5 Nm (0.37 lb ft)	-
5	Screws for fastening the grilles to the saddle mounting	M5	2	3 Nm (2.21 lb ft)	-
6	Screws used to fasten the tail fairing to the saddle support bracket	M5	2	2 Nm (1.48 lb ft)	-
7	Lower saddle mounting closure fastening screws	M5	2	3 Nm (2.21 lb ft)	-
8	Screws for fastening number plate holder to the saddle mounting plate	M6	2	4 Nm (2.95 lb ft)	-
9	Screws for fastening the rear number plate holder to the front number plate holder	SWP 3,9	4	1 Nm (0.74 lb ft)	-
10	Self-tapping screws for fastening the rear number plate holder to the front number plate holder	SWP 4.9	2	2 Nm (1.48 lb ft)	-
11	Reflector retaining nuts	M4	2	1 Nm (0.74 lb ft)	-
12	License plate light fixing screw	M4	1	1 Nm (0.74 lb ft)	-

Pos.	Description	Type	Quantity	Torque	Notes
13	Nuts for fastening the number plate holder to the saddle mounting	M6	2	4 Nm (2.95 lb ft)	-
-	Screw for fastening the tail fairing to the taillight bracket	M5	2	3 Nm (2.21 lb ft)	-
-	V4-MP control unit retaining screws (if fitted)	Self-tapping Di-am. 3.9	2	0.3 Nm (0.22 lb ft)	-

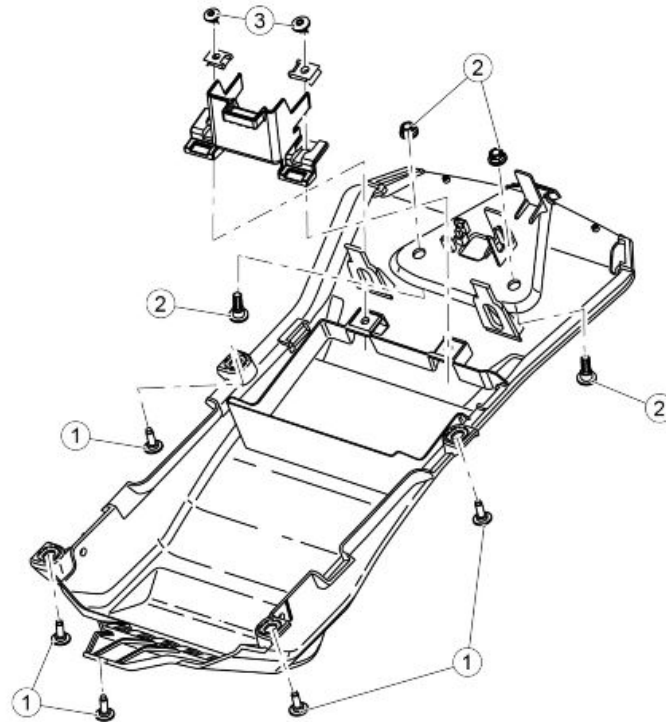

BODYWORK UNDER SADDLE

Pos.	Description	Type	Quantity	Torque	Notes
1	Flanged button head hex. socket screws for fastening the saddle mounting	M5x12	5	3 Nm (2.21 lb ft)	-
2	Screws and nuts for fastening the number plate holder to the saddle mounting plate	M6	2	4 Nm (2.95 lb ft)	-
3	Button head hex socket battery bracket fastening screws	M5	5	2 Nm (1.48 lb ft)	-

Engine

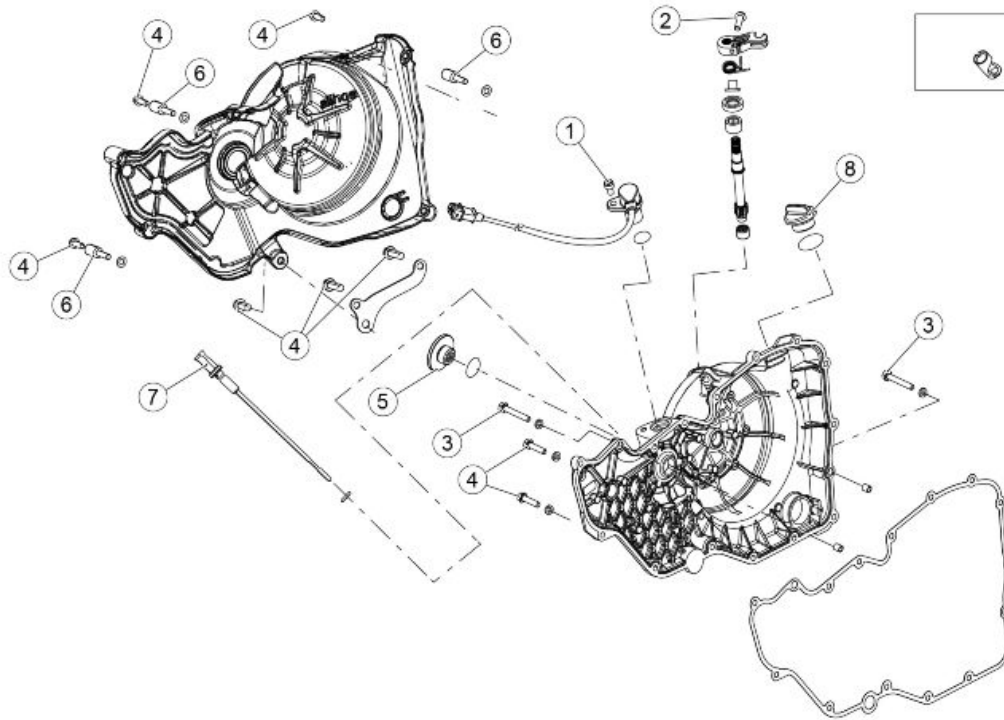

CLUTCH COVER

Pos.	Description	Type	Quantity	Torque	Notes
1	Rpm sensor fixing screw	-	1	8 Nm (5.90 lb ft)	-
2	TE Flanged screw	M6x20	1	10 Nm (7.38 lb ft)	-
3	TE Flanged screw	M6x35	2	12 Nm (8.85 lb ft)	Tighten to torque, unscrew and re-tighten to torque.
4	TE Flanged screw	M6x22	14	12 Nm (8.85 lb ft)	Tighten to torque, unscrew and re-tighten to torque.
5	Engine timing inspection cap	-	1	20 Nm (14.75 lb ft)	-
6	Spacers for soundproof cover	-	5	6 Nm (4.43 lb ft)	-
7	Oil level dipstick	-	1	3 Nm (2.21 lb ft)	-
8	Oil load cap	-	1	5 Nm (3.69 lb ft)	-

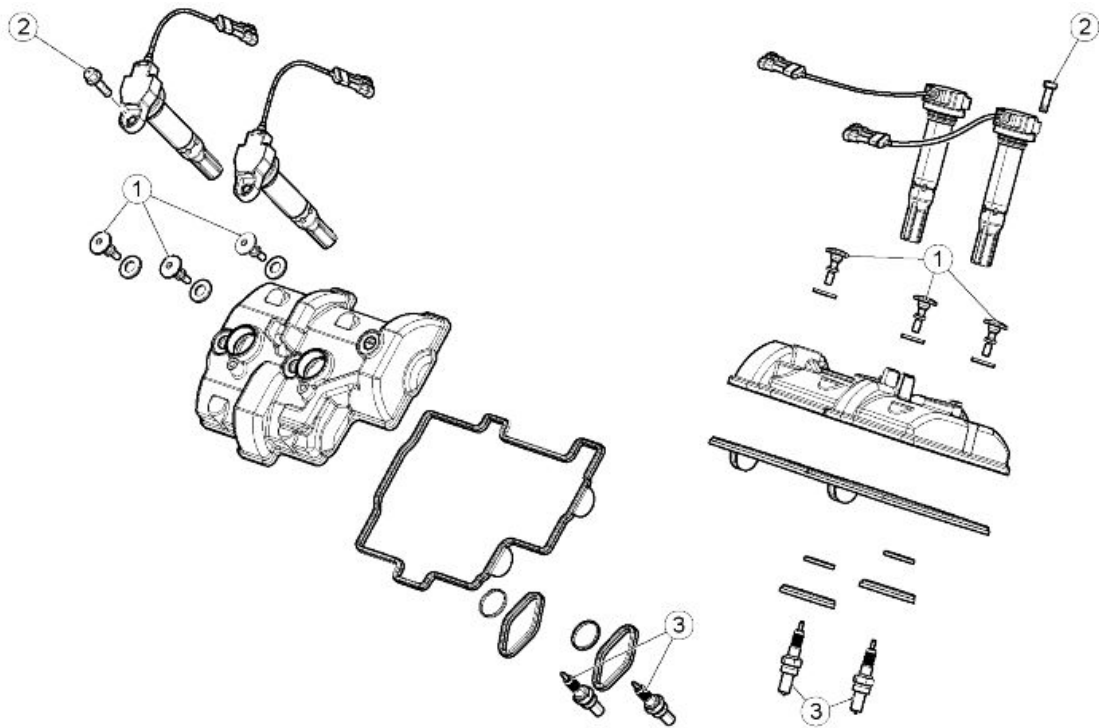

VALVES COVER

Pos.	Description	Type	Quantity	Torque	Notes
1	Head cover fixing screws	-	6	10 Nm (7.38 lb ft)	-
2	TE flanged coil fixing screw	M6x12	4	8 Nm (5.90 lb ft)	Loct. 243
3	Spark plugs	-	4	12 Nm (8.85 lb ft)	-

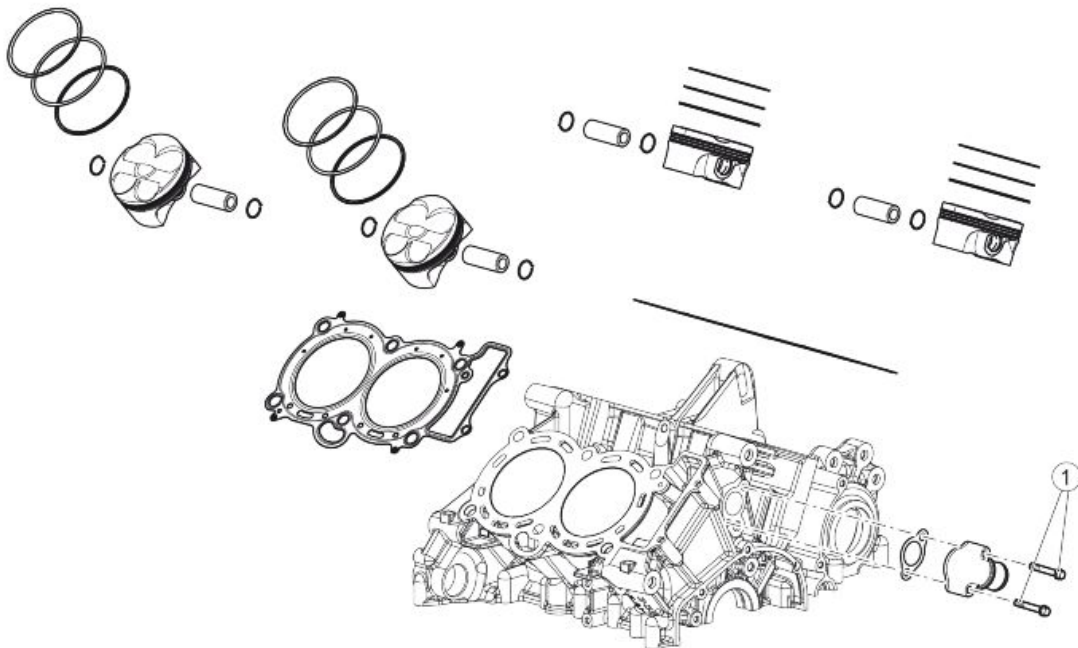

CYLINDERS - PISTON

pos.	Description	Type	Quantity	Torque	Notes
1	Screws fastening water union onto crankcase	M6x40	2	10 Nm (7.38 lb ft)	-

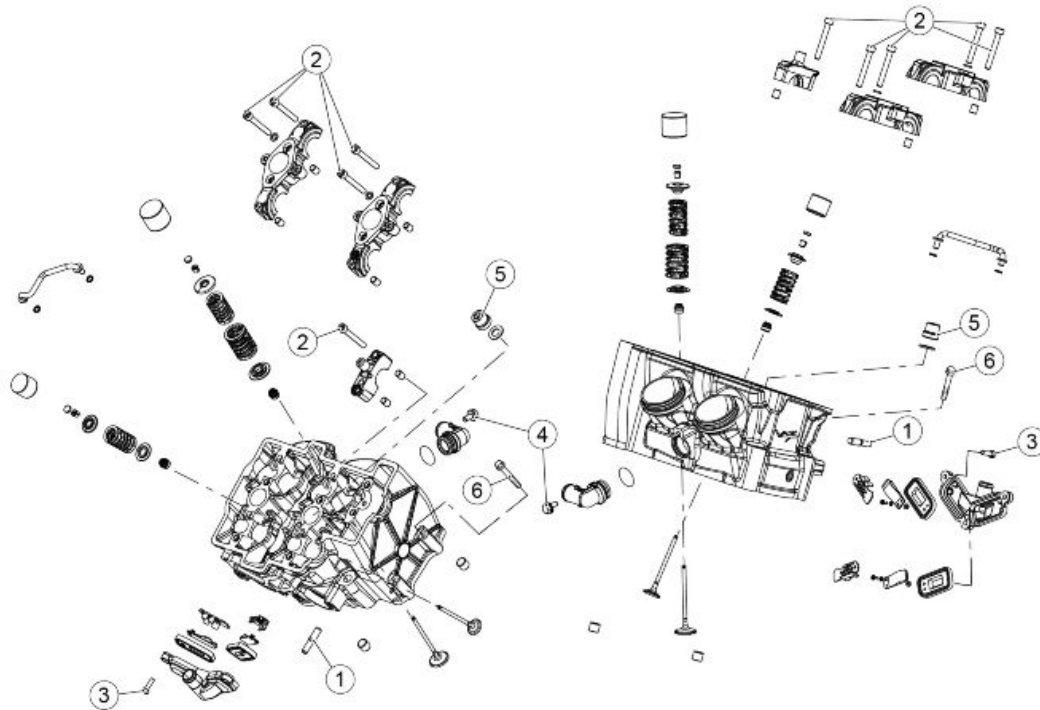

HEADS

Pos.	Description	Type	Quantity	Torque	Notes
1	Exhaust stud bolts	-	8	10 Nm (7.38 lb ft)	-
2	Cam shaft cam tower fixing screws	M6x45	20	11 Nm (8.11 lb ft)	-
3	Reed valve covers fixing screws	-	6	6 Nm (4.43 lb ft)	-
4	Water outlet coupling fixing screw	-	2	10 Nm (7.38 lb ft)	Pre-impregnated or else Loct. 270 or Loct. 648
5	Flanged head nut	-	12	30 + 55 Nm (22.13 + 40.57 lb ft)	Lubricate the head and under the head.
6	Head tightening screw, chain side	M6x55	4	12 Nm (8.85 lb ft)	Lubricate the head and under the head.

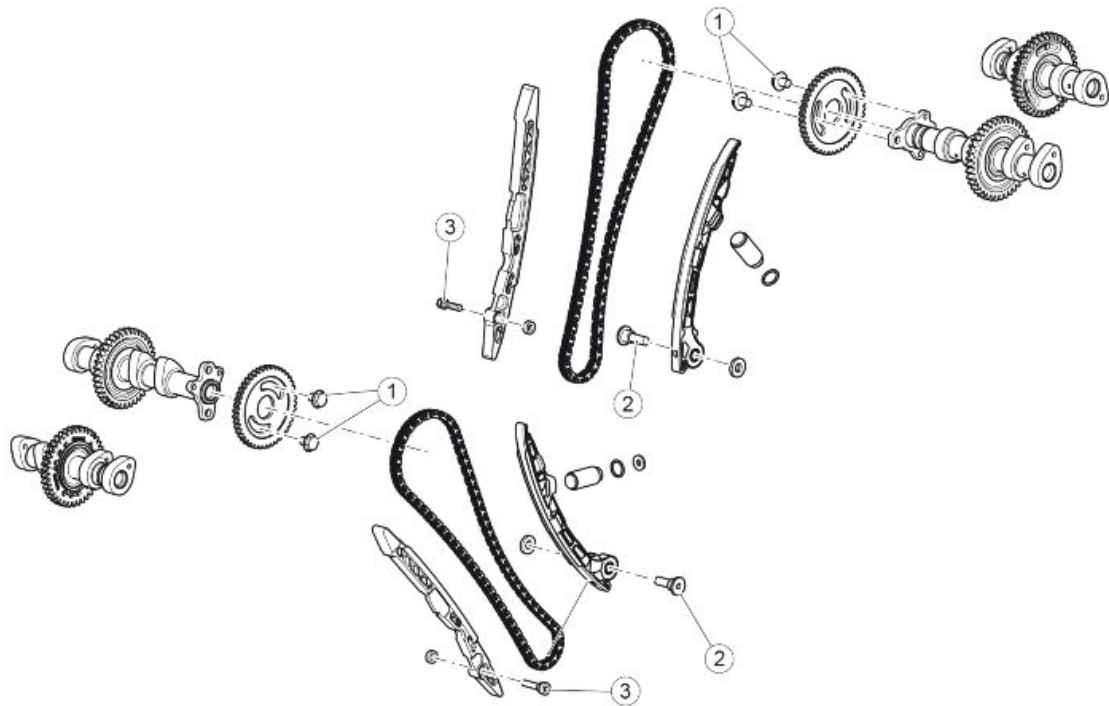

TIMING SYSTEM

Pos.	Description	Type	Quantity	Torque	Notes
1	Screw fastening the timing system gear on the intake shaft	M8	4	30 Nm (22.13 lb ft)	Loct. 243
2	Chain tensioner sliders fastening screws	M8	2	20 Nm (14.75 lb ft)	Loct. 243
3	Chain guide sliders fixing screws	M6x18	2	10 Nm (7.38 lb ft)	Loct. 243

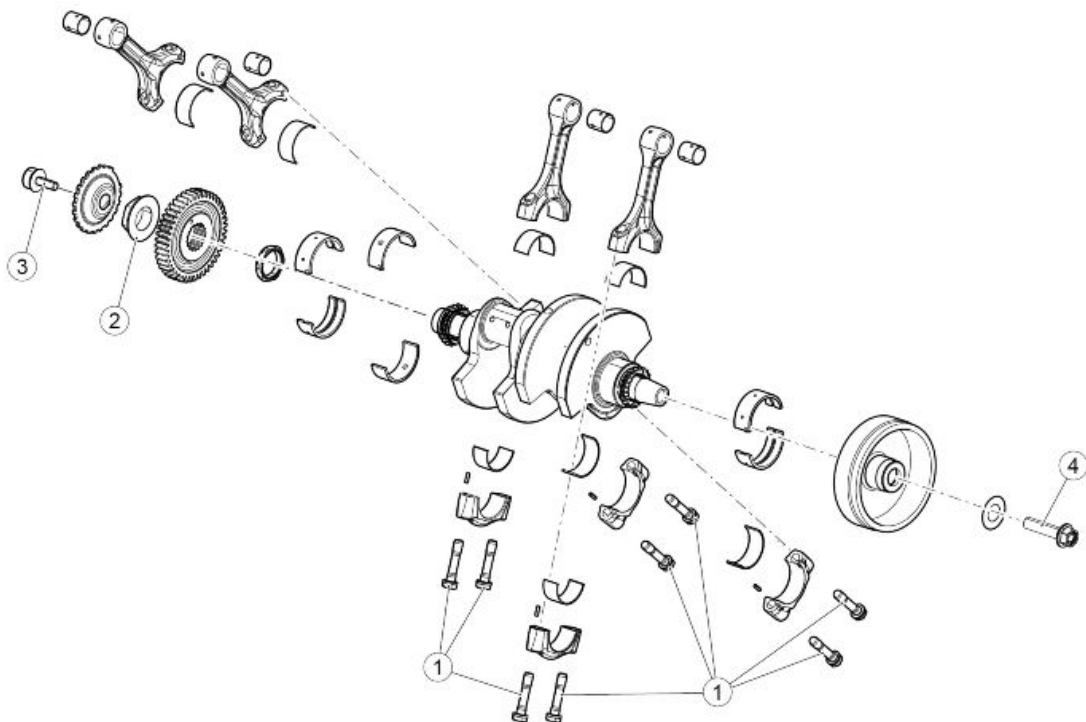

CRANKSHAFT

Pos.	Description	Type	Quantity	Torque	Notes
1	Connecting rod screws	-	8	15 + 20 Nm (11.06 + 14.75 lb ft) + 130°	Lubricate the head and under head with con PANKL Lubricant 01 (PLB01)
2	Primary fixing ring nut	-	1	200 Nm (147.51 lb ft)	Loct. 243
3	Tone wheel fastener screw	M8x24	1	50 Nm (36.88 lb ft)	Pre-impregnated, in absence Loct.270 or Loct.648
4	Generator fixing screw	M12x1.25	1	120 Nm (88.51 lb ft)	-

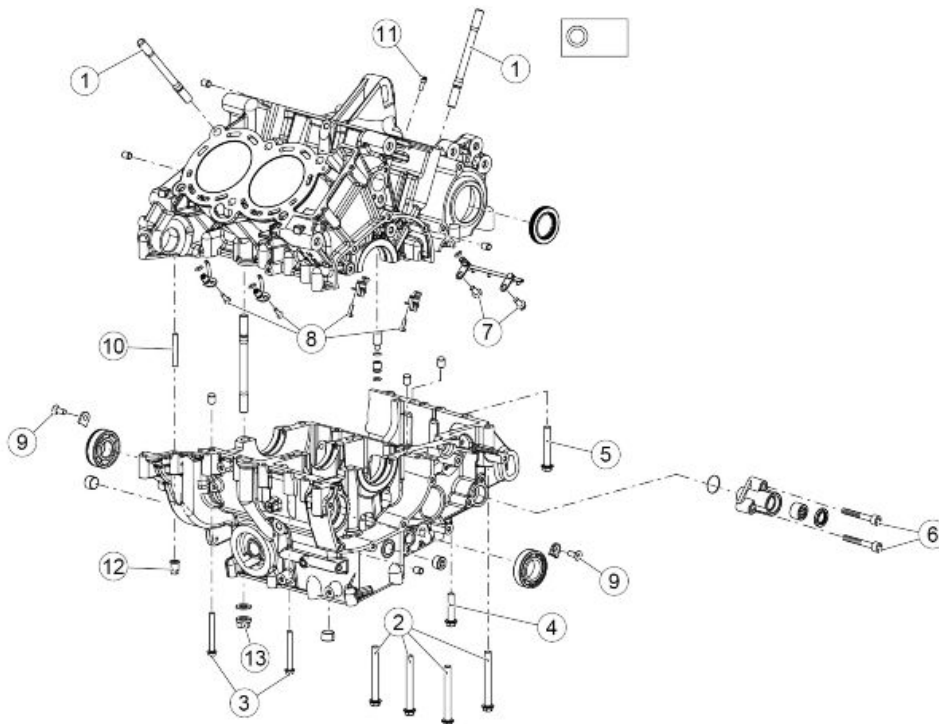

CRANKCASE

Pos.	Description	Type	Quantity	Torque	Notes
1	Stud bolts	M10	18	20 Nm (14.75 lb ft)	Loct. 270
2	TE Flanged screw	M8x70	4	25 Nm (18.44 lb ft)	Lubricate the head and under the head.
3	TE Flanged screw	M6x50	8	10 Nm (7.38 lb ft)	Lubricate the head and under the head.
4	TE Flanged screw	M8x35	1	25 Nm (18.44 lb ft)	Lubricate the head and under the head.
5	TE Flanged screw	M8x50	3	25 Nm (18.44 lb ft)	Lubricate the head and under the head.
6	Gearbox control rod support SHC fixing screws	M6x35	2	10 Nm (7.38 lb ft)	Lubricate the head and under the head.
7	Flanged TE screw fixing fuel rail gearbox lubrication	M6x12	2	10 Nm (7.38 lb ft)	Pre-impregnated screw and in absence Loct.2045
8	TB TORX screw	4x12	4	5 Nm (3.69 lb ft)	Pre-impregnated screw, in absence Loct.2045
9	TSPEI screw fixing bearing stop plates	M6x16	2	10 Nm (7.38 lb ft)	Loct. 243
10	Stud bolt	M6	1	Bring to 33mm from the surface	Loct. 648

Pos.	Description	Type	Quantity	Torque	Notes
11	SHC screw	M6x40	1	10 Nm (7.38 lb ft)	Lubricate the head and under the head.
12	Special nut	-	1	10 Nm (7.38 lb ft)	-
13	Flanged nut	M10	6	15 + 20 Nm (11.06 + 14.75 lb ft) + 60° + 60°	Lubricate the head and under the head. Use the sequence: 1) Pre-tighten to 15 Nm (11.06 lb ft); 2) Tighten to 20 Nm (14.75 lb ft); 3) Tighten applying an angle of 60° +/- 2; 4) Repeat the operation for another 60° +/- 2
-	Screw fastening ground cable to the engine	M6	2	6 Nm (4.43 lb ft)	-

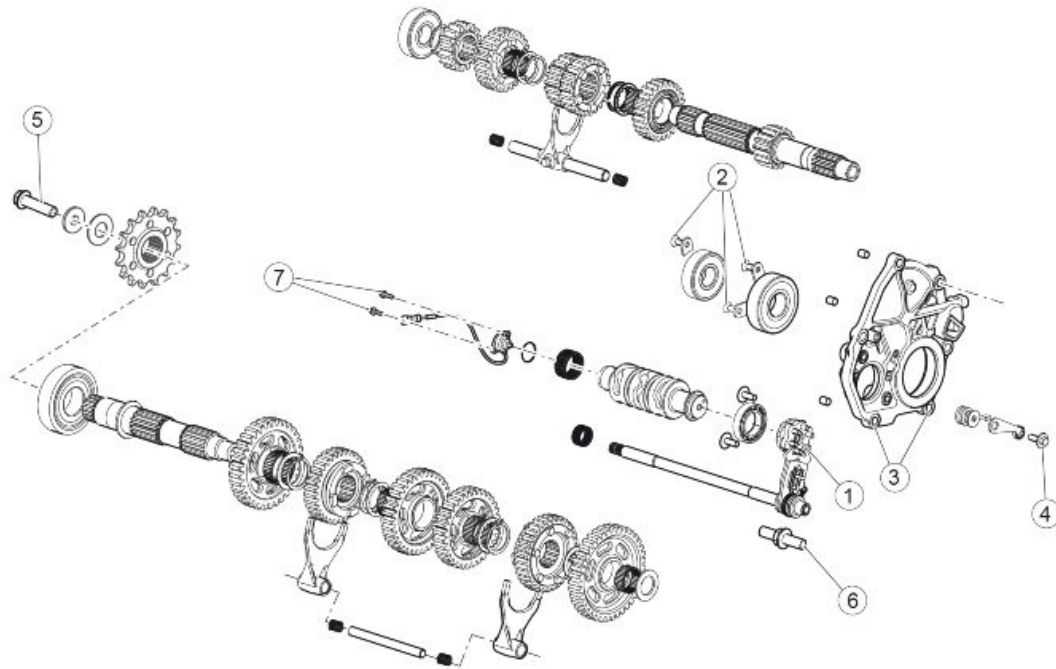

GEARBOX

Pos.	Description	Type	Quantity	Torque	Notes
1	"Philips" cylindrical head hex. socket screw	M6x20	1	10 Nm (7.38 lb ft)	Loct. 243
2	Hex. socket flat head counter sunk screw for fastening the bearing retaining plates	M6x16	3	10 Nm (7.38 lb ft)	Loct. 243
3	Flanged, hex. head flange retaining screws	M8x25	6	25 Nm (18.44 lb ft)	-
4	Special screw with index lever fastening collar	M6	1	10 Nm (7.38 lb ft)	Loct. 243
5	Pinion fastening	-	1	50 Nm (36.88 lb ft)	Loct. 243
6	Pre-selector retaining screw on crankcase	-	1	25 Nm (18.44 lb ft)	Pre-impregnated screw in absence of 3M 2353
7	Flanged, hex. head gear indicator fastening screws	M5x15	2	6 Nm (4.43 lb ft)	-

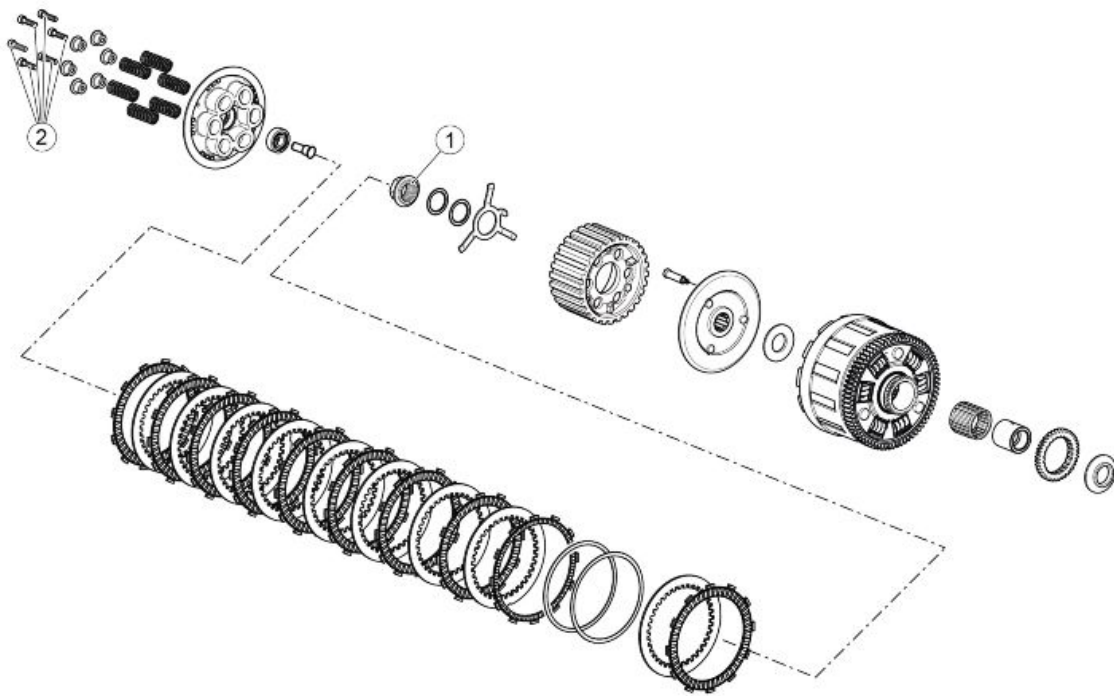

CLUTCH

Pos.	Description	Type	Quantity	Torque	Notes
1	Flanged nut fixing clutch	M20x1	1	150 Nm (110.63 lb ft)	Loct. 243
2	Clutch springs SHC fixing screw	M6x25	6	10 Nm (7.38 lb ft)	-

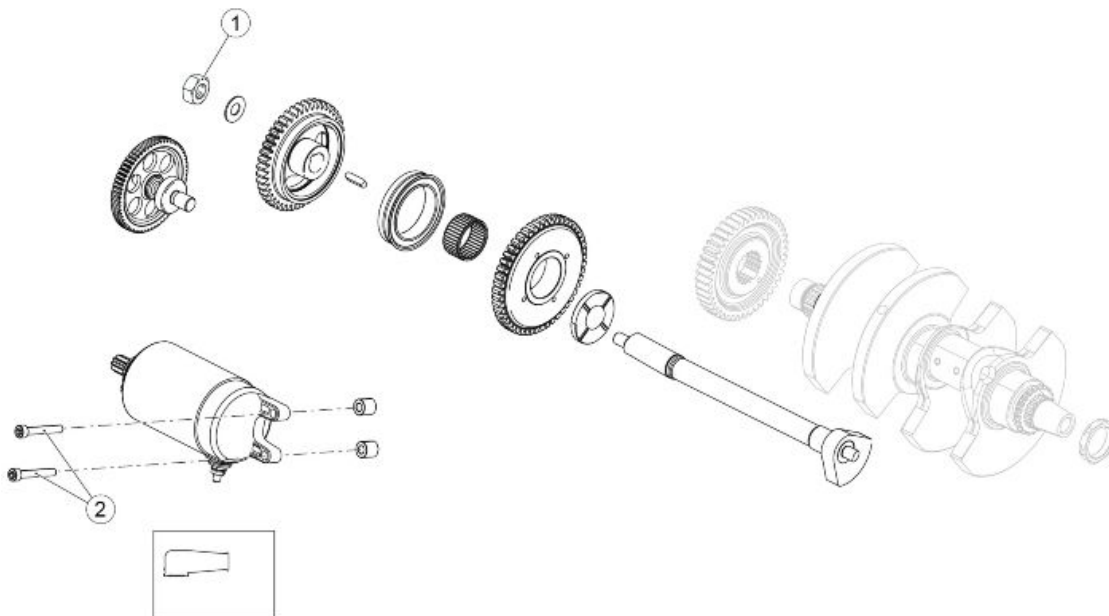

IGNITION UNIT

Pos.	Description	Type	Quantity	Torque	Notes
1	Hex headed nut cl.10 type 2 iso 8674	M10x1	1	50 Nm (36.88 lb ft)	Loct. 243

Pos.	Description	Type	Quantity	Torque	Notes
2	Starter motor SHC fastener screw	M6x40	2	10 Nm (7.38 lb ft)	-
-	Screw fastening cables to the starter motor	M6	1	6 Nm (4.43 lb ft)	-

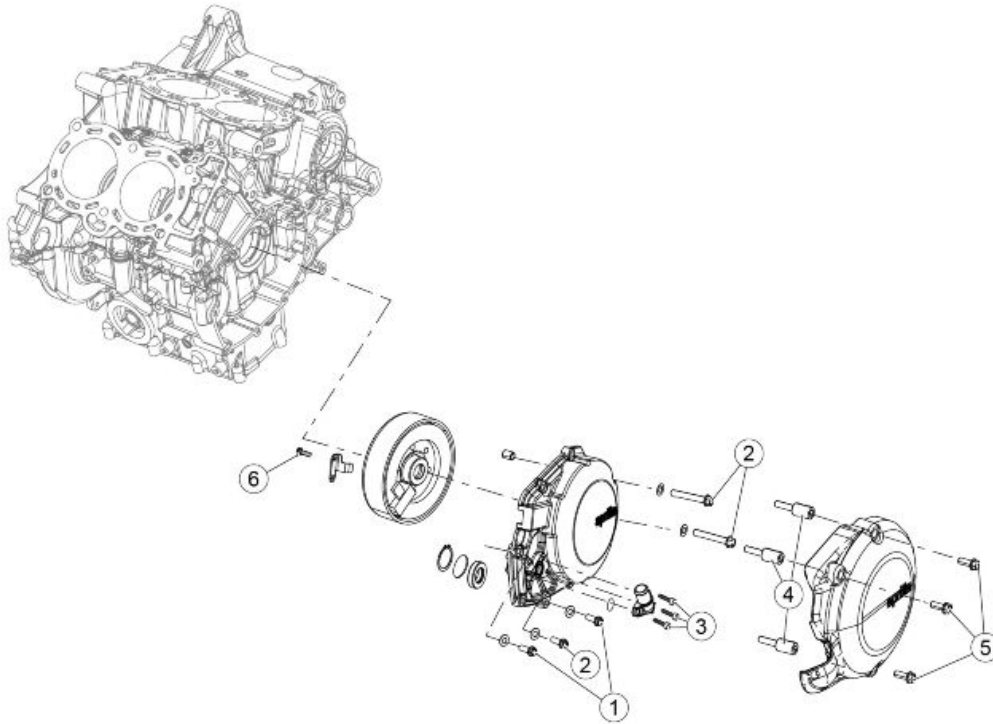

GENERATOR COVER

Pos.	Description	Type	Quantity	Torque	Notes
1	Cover fastening screws	M6x25	2	12 Nm (8.85 lb ft)	Tighten to torque, unscrew and re-tighten to torque.
2	Cover fastening screws	M6x40	3	12 Nm (8.85 lb ft)	Tighten to torque, unscrew and re-tighten to torque.
3	Blow-by coupling SHC fastening screws	M5x16	3	5 Nm (3.69 lb ft)	-
4	Spacers for soundproof cover	-	3	6 Nm (4.43 lb ft)	-
5	Soundproof cover fastening screws	M6	3	6 Nm (4.43 lb ft)	-
6	TE flanged screw fixing the cable tie plate	M5x12	1	6 Nm (4.43 lb ft)	Pre-impregnated screw and in absence Loct.2045
-	Stator SHC fixing screw	M6x30	1	10 Nm (7.38 lb ft)	Pre-impregnated screw and in absence Loct.2045

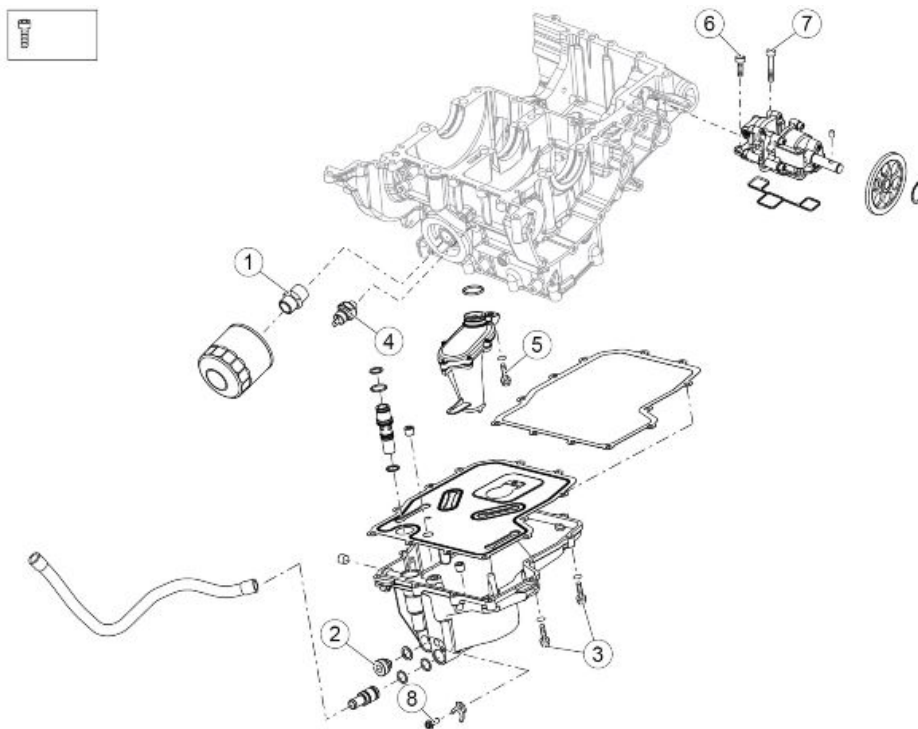

LUBRICATION SYSTEM

Pos.	Description	Type	Quantity	Torque	Notes
1	Oil filter coupling fastening screw	-	1	30 Nm (22.13 lb ft)	-
2	Oil drainage plug	-	1	30 Nm (22.13 lb ft)	-
3	Oil sump fixing screws	M6x30	12	12 Nm (8.85 lb ft)	Tighten to torque, unscrew and re-tighten to torque.
4	Oil pressure sensor	-	1	15 Nm (11.06 lb ft)	-
5	Flanged TE rose pipe fastening screw	M6x16	1	10 Nm (7.38 lb ft)	Pre-impregnated screw, in absence Loct.2045
6	SHC screw fixing pump to the casing	M6x16	5	10 Nm (7.38 lb ft)	-
7	SHC screw fixing pump to the casing	M6x50	1	10 Nm (7.38 lb ft)	-
8	SHC screw fixing oil pipe connection	M6x20	1	10 Nm (7.38 lb ft)	-

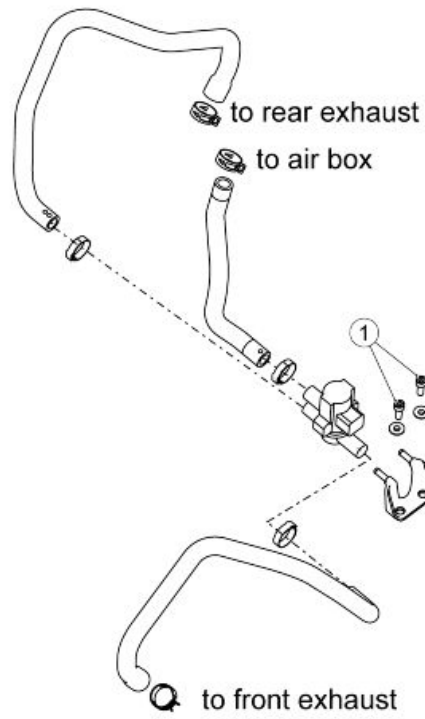

SECONDARY AIR SYSTEM

Pos.	Description	Type	Quantity	Torque	Notes
1	Cylindrical head, hex. socket secondary air solenoid screws	M6x16	2	10 Nm (7.38 lb ft)	-

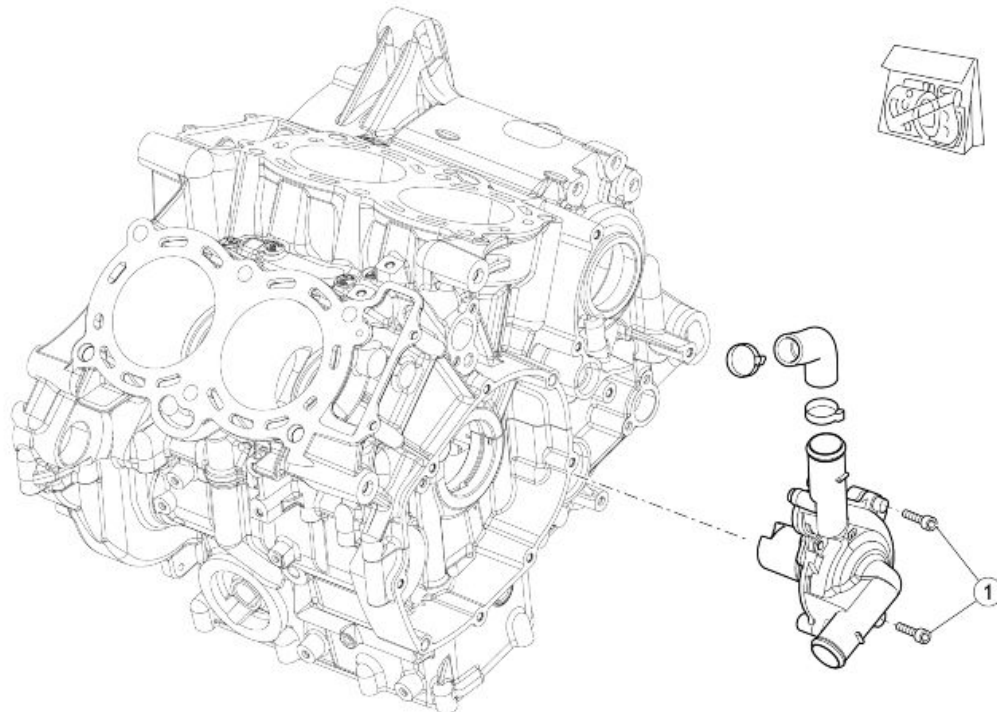

WATER PUMP

Pos.	Description	Type	Quantity	Torque	Notes
1	Cylindrical head, hex. socket screws for fastening the pump to the crank-case	M6x25	2	10 Nm (7.38 lb ft)	-

INDEX OF TOPICS





SSPECIAL TOOLS

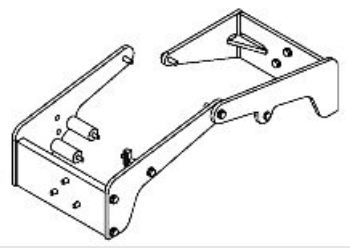
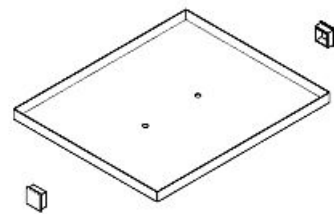
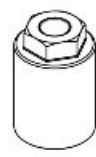
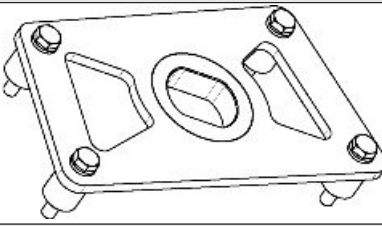
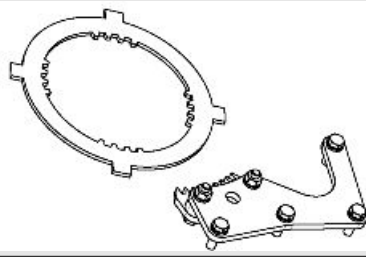
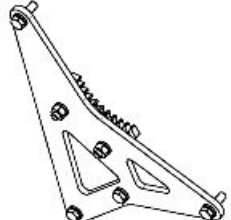

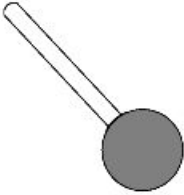
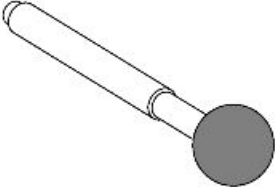
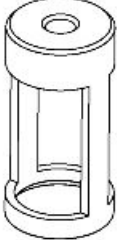
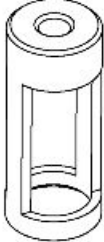
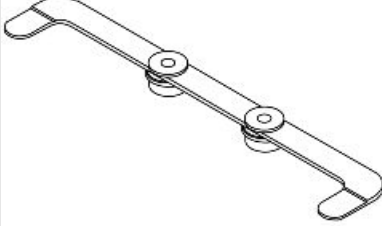
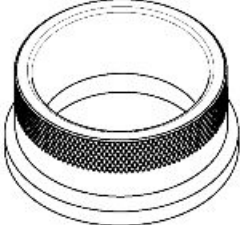
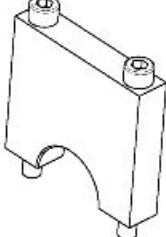
S-TOOLS

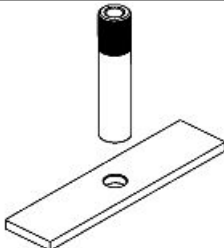

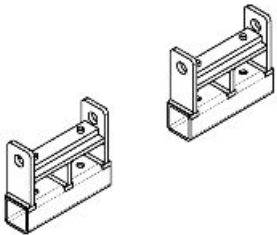

SPECIAL TOOLS

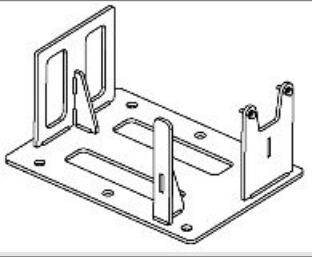
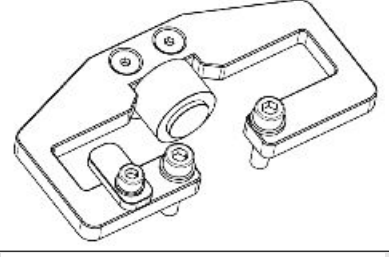
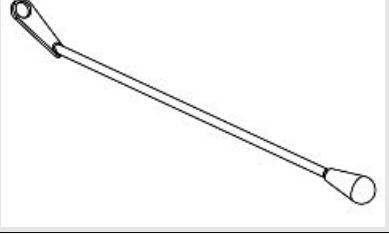
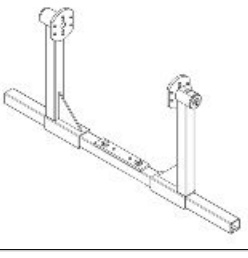
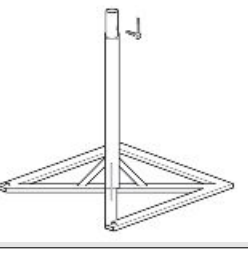
Stores code	Description	
020845Y	Engine support	
020846Y	Containment tray + plastic plugs	
020847Y	Flywheel extractor	
020914Y	Flywheel retainer	
020849Y	Clutch lock	
020850Y	Primary gear lock	

Stores code	Description	
020851Y	Camshaft timing pin	
020852Y	Crankshaft timing pin	
020853Y	Compresses intake valve springs	
020854Y	Compresses exhaust valve springs	
020981Y	Lever for disarming the hydraulic tensioner of the timing chain	
020856Y	Piston assembly ring	
020857Y	Crankshaft support U-bolt	

Stores code	Description	
020858Y	Maintenance of the pistons in the cylinders	
AP8140199	Tool storage panel	
020859Y 8140426	Graphics for panels Hooks for panel	
020860Y	Motor support extension	
020862Y	Punch assembly cage with rollers gear-box control rod.....	
020863Y	Punch assembly cage with rollers desmodromic drum.....	

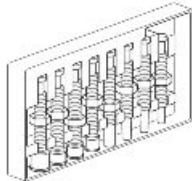
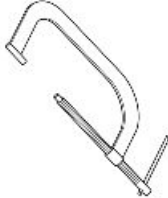
Stores code	Description	
020864Y	Engine mounting plate	
020956Y	Support for camshaft gear on head	
020883Y	Fitting/removing timing chain tensioner tool	
020709Y	Engine support	
AP8140187	U-bolt for motor support	
020376Y	Sleeve for adaptors	
020363Y	20mm oil seal guide	

Stores code	Description	
020364Y	25-mm guide	
020359Y	42 x 47 mm punch	
020431Y	Valve oil seal extractor	
AP8140180	Bearing extractor	
AP8140179	Valve springs compressor	
0277308	Guide bushing for gearbox secondary shaft	

Stores code	Description
-------------	-------------

020877Y

Calliper for clamps

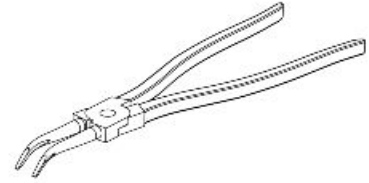

020926Y

Tool for fitting clutch bushing

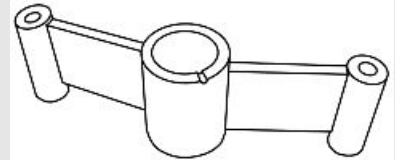

AP8140146

Weight

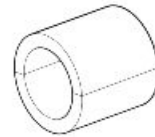

AP8140189

Tool for fitting oil seal for 43 mm (1.69 in) diameter hole

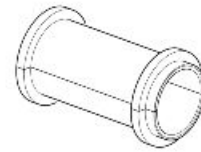

AP8140147

Spacer retaining device

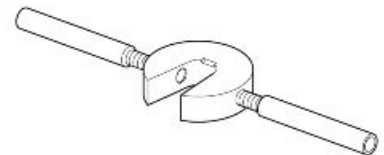

AP8140148

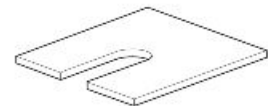

Plunger-spacer separator plate

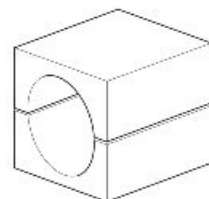

AP8140149

Guard for assembly operations

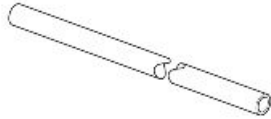
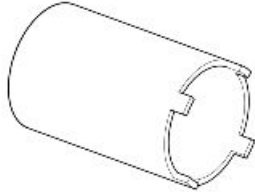

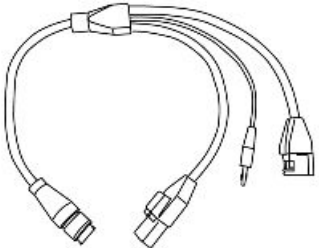
Stores code	Description	
AP8140150	Bored shaft for bleeding plunger air	
AP8140190	Tool for steering tightening	
AP8140181	Tool for checking fuel pressure	
020922Y	Diagnostic tool	
021011Y	PADS - PMP Interface cable	

INDEX OF TOPICS

MAINTENANCE

MAIN

Scheduled maintenance table

NOTE

CARRY OUT MAINTENANCE OPERATIONS AT HALF THE INTERVALS SPECIFIED IF THE VEHICLE IS USED IN PARTICULAR RAINY OR DUSTY CONDITIONS, OFF ROAD OR FOR TRACK USE.

NOTE

THE TIMES LISTED ON THE SCHEDULED MAINTENANCE TABLE INCLUDE TIME DEDICATED TO MANAGEMENT ACTIVITIES.

I: INSPECT AND CLEAN, ADJUST, LUBRICATE OR REPLACE IF NECESSARY

C: CLEAN, R: REPLACE, A: ADJUST, L: LUBRICATE

- (1) Check at each engine start.
- (2) Check and clean and adjust or replace, if necessary, before every journey.
- (3) Check and clean, adjust or replace if necessary every 1,000 km (621.37 mi).
- (4) Replace every 4 years.
- (5) Every 5,000 Km (3,106.86 mi) if the vehicle is used for racing.
- (6) Every 10,000 Km (6,213.71 mi) if the vehicle is used for racing.
- (7) Your RSV4 is equipped with a sophisticated system, based on exchangeable conical bushes that allow the modification of the steering angle for track use. In case of prolonged road use in conditions with uneven ground (e.g. use on pave, holes, speed bumps) can bring small adjustments that, in extreme cases, can cause a slight clearance to the handlebar. Therefore it is recommended to perform the check and adjustment operations at an Authorised Aprilia-Piaggio Workshop every 5,000 km (3,106.86 mi).
- (8) Replace at whichever of the following occurs first: 40,000 km (24,854.85 mi) or 4 years.

SCHEDULED MAINTENANCE TABLE

Km x 1,000 (mi x 1,000)	1 (0.6)	10 (6.2)	20 (12.4)	30 (18.6)	40 (24.9)	EVERY 12 MONTHS	EVERY 24 MONTHS
Rear shock absorber (bearings - linkage systems) (5)			I		I	I	I
Motorcycle set up (5)	I	I	I	I	I		
Spark plug			R		R		
Drive chain (3)	I - L	I - L	I - L	I - L	I - L	I	I
Clutch cable	L	L	L	L	L	L	L
Exhaust valve control cables (5)	A	A	A	A	A	A	A
Crown wheel - sprocket (5)		I	I	I	I		
Steering bearings and steering play (7)	I	I	I	I	I	I	I
Wheel bearings - Wheels (5)	I	I	I	I	I	I	I
Diagnosis by tool	I	I	I	I	I	I	I
Brake discs (5) - Pads wear (2)	I	I	I	I	I	I	I
Air filter (5)		I	R	I	R		
Engine oil filter (5)	R	R	R	R	R	R	R
Fork			I		I	I	I
General vehicle operation (5)	I	I	I	I	I	I	I
Valve clearance (6)			A		A		
Cooling system (5)		I	I	I	I		
Brake systems (5)	I	I	I	I	I	I	I
Light circuit	I	I	I	I	I	I	I
Safety switches (stand, stop, clutch, extra negative stroke, gas control)	I	I	I	I	I	I	I

Km x 1,000 (mi x 1,000)	1 (0.6)	10 (6.2)	20 (12.4)	30 (18.6)	40 (24.9)	EVERY 12 MONTHS	EVERY 24 MONTHS
Brake fluid	I	I	I	I	I	I	R
Coolant	I	I	I	I	I	I	R
Fork oil (6) (8)					R		
Engine oil (5)	R	R	R	R	R	R	R
Headlight aiming		I	I	I	I		
Fork oil seals (5)		I		I			
Slipper mechanism			I		I		
Tyres - pressure / wear (2)	I	I	I	I	I	I	I
Nut/bolt tightness (5)	I	I	I	I	I		
Flexible coupling pin nuts tightening	I						
Clutch cover, flywheel and sump screw tightness	I	I	I	I	I		
Fault indicator light on instrument cluster (1)							
Fuel lines (4)		I	I	I	I	I	I
Clutch wear (6)			I		I		
Labour time (minutes) - RF/RR	130	160	390	160	480	110	140

The scheduled maintenance table refers to road use. In case of using the new RSV4 on a competitive level, as for sport events and use on the track, in order to correctly monitor the effective degree of technological stress of the mechanical components, an electric device intervenes that registers the engine performance and allows to plan eventual maintenance. Therefore, when the general warning light (see figure) steadily lights up for 2 seconds, each 120 seconds, it is necessary to contact an Authorised Service Centre to plan the specific maintenance intervention, which is recommended by the manufacturer.

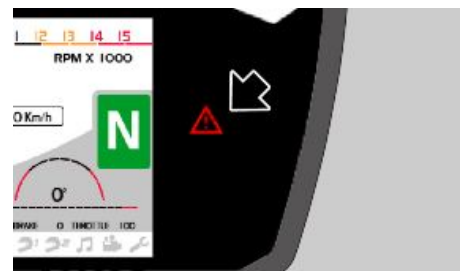

To carry out the correct verification "Flexible coupling pin nuts tightening" indicated in the scheduled maintenance table, refer to the corresponding procedure in chapter "Maintenance / Verification Flexible coupling"

SCHEDULED MAINTENANCE TABLE RESERVED FOR THE USA-LATAM MARKET

I: CONTROLLARE E PULIRE, REGOLARE, LUBRIFICARE O SOSTITUIRE SE NECESSARIO

C: PULIRE, R: SOSTITUIRE, A: REGOLARE, L: LUBRIFICARE

- (1) Controllare ad ogni avviamento.
- (2) Controllare e pulire, regolare o sostituire se necessario prima di ogni viaggio.
- (3) Controllare e pulire, regolare o sostituire se necessario ogni 621.37 mi (1000 km).
- (4) Sostituire ogni 2 anni.
- (5) Sostituire ogni 4 anni.
- (6) Ogni 3106.86 mi (5000 km) nel caso di utilizzo sportivo.
- (7) Ogni 6213.17 mi (10000 km) nel caso di utilizzo sportivo.

(8) La Vostra RSV4 è dotata di un sofisticato sistema, basato su boccole coniche intercambiabili, che consente di modificare l'angolo di sterzo per l'uso in pista. Nel caso di utilizzo stradale prolungato in condizioni di fondo sconnesso (es. impiego su pavé, buche, rallentatori ecc.) possono verificarsi piccoli assestamenti che, in casi limite, possono fare insorgere un leggero gioco al manubrio. Si consiglia pertanto di effettuare l'operazione di controllo e regolazione in Officina Autorizzata Aprilia-Piaggio ad intervalli di 3106.86 mi (5000 km).

(9) Sostituire al raggiungimento della prima opzione tra le due seguenti: 24854.85 mi (40000 km) oppure 4 anni.

TABELLA DI MANUTENZIONE PROGRAMMATA

mi x 1.000 (km x 1.000)	0.6 (1)	6.2 (10)	12.4 (20)	18.6 (30)	24.9 (40)
Rear shock absorber (bearings - linkage systems) (6)			I		I
Motorcycle set up (6)	I	I	I	I	I
Spark plug			R		R
Drive chain (3)	I - L	I - L	I - L	I - L	I - L
Clutch cable	L	L	L	L	L
Exhaust valve control cables (6)	A	A	A	A	A
Crown wheel - sprocket (6)		I	I	I	I
Steering bearings and steering play (8)	I	I	I	I	I
Wheel bearings - Wheels (6)	I	I	I	I	I
Diagnosis by tool	I	I	I	I	I
Brake discs (6) - Pads wear (2)	I	I	I	I	I
Air filter (6)		I	R	I	R
Engine oil filter (6)	R	R	R	R	R
Fork			I		I
General vehicle operation (6)	I	I	I	I	I
Valve clearance (7)			A		A
Cooling system (6)		I	I	I	I
Brake systems (6)	I	I	I	I	I
Light circuit	I	I	I	I	I
Safety switches (stand, stop, clutch, extra negative stroke, gas control)	I	I	I	I	I
Brake fluid (4)	I	I	I	I	I
Coolant (4)	I	I	I	I	I
Fork oil (7) (9)					R
Engine oil (6)	R	R	R	R	R
Headlight aiming		I	I	I	I
Fork oil seals (6)		I		I	
Slipper mechanism			I		I
Tyres - pressure / wear (2)	I	I	I	I	I
Nut/bolt tightness (6)	I	I	I	I	I
Flexible coupling pin nuts tightening	I				
Clutch cover, flywheel and sump screw tightness	I	I	I	I	I
Fault indicator light on instrument cluster (1)					
Fuel lines (5)		I	I	I	I
Clutch wear (7)			I		I
Verifica gioco cavi valvola di scarico	A	A	A	A	A

SCHEDULED MAINTENANCE TABLE ONLY FOR THE ASIA/PACIFIC MARKET

SCHEDULED MAINTENANCE TABLE

km x 1,000 or (months) maximum	1 (1)	10 (10)	20 (20)	30 (30)	40 (40)
Rear shock absorber (bearings - linkage systems) (6)			I		I
Motorcycle set up (6)	I	I	I	I	I
Spark plug			R		R
Drive chain (3)	I - L	I - L	I - L	I - L	I - L
Clutch cable	L	L	L	L	L
Exhaust valve control cables (6)	A	A	A	A	A

km x 1,000 or (months) maximum	1 (1)	10 (10)	20 (20)	30 (30)	40 (40)
Crown wheel - sprocket (6)		I	I	I	I
Steering bearings and steering play (8)	I	I	I	I	I
Wheel bearings - Wheels (6)	I	I	I	I	I
Diagnosis by tool	I	I	I	I	I
Brake discs (6) - Pads wear (2)	I	I	I	I	I
Air filter (6)		I	R	I	R
Engine oil filter (6)	R	R	R	R	R
Fork			I		I
General vehicle operation (6)	I	I	I	I	I
Valve clearance (7)			A		A
Cooling system (6)		I	I	I	I
Brake systems (6)	I	I	I	I	I
Light circuit	I	I	I	I	I
Safety switches (stand, stop, clutch, extra negative stroke, gas control)	I	I	I	I	I
Brake fluid (4)	I	I	I	I	I
Coolant (4)	I	I	I	I	I
Fork oil (7) (9)					R
Engine oil (6)	R	R	R	R	R
Headlight aiming		I	I	I	I
Fork oil seals (6)		I		I	
Slipper mechanism			I		I
Tyres - pressure / wear (2)	I	I	I	I	I
Nut/bolt tightness (6)	I	I	I	I	I
Flexible coupling pin nuts tightening	I				
Clutch cover, flywheel and sump screw tightness	I	I	I	I	I
Fault indicator light on instrument cluster (1)					
Fuel lines (5)		I	I	I	I
Clutch wear (7)			I		I
Labour time (minutes) - RF/RR	130	160	390	160	480

NOTE

AT EACH SCHEDULED MAINTENANCE MUST BE VERIFIED WITH THE DIAGNOSTIC TOOL IF THERE ARE ERRORS AND THE IF THE PARAMETERS ARE CORRECT. ENSURE THAT THE VEHICLE CALIBRATION IS UP TO DATE AFTER UPDATING THE DIAGNOSTIC TOOL.

CAUTION

AFTER THE PROVIDED MAINTENANCE PROGRAM IS INDICATED TO PROCEED WITH THE MAINTENANCE OF THE VEHICLE STARTING FROM THE SERVICE OF 10,000 Km OR 10 MONTHS

Maintenance table for track use

I: INSPECT AND CLEAN, ADJUST, LUBRICATE OR REPLACE IF NECESSARY

R: REPLACE

EQUIVALENT KILOMETRES TABLE

Km x 1,000	6	12	18	24	30	36
Intake valve spring	R	R	R	R	R	R
Exhaust valve prong	R	R	R	R	R	R
Intake caps			R			R
Exhaust caps			R			R
Intake valves			R			R
Exhaust valves			R			R
Intake cam			I			I
Exhaust cam			I			I
Valve seats			I			I
Chains	I	I	R	I	I	R
Chain pads	I	I	R	I	I	R
Complete connecting rod			R			R
Big-end bearing			R			R
Main bearings			R			R

Km x 1,000	6	12	18	24	30	36
Drive side balance shaft bearing		R		R		R
Flywheel side balance shaft bearing		R		R		R
Pistons			R			R
Gear selector fork	R	R	R	R	R	R
Oil intake rose pipe			R			R
Spark plugs	R	R	R	R	R	R
Engine oil filter	R	R	R	R	R	R
Air filter	R	R	R	R	R	R
Valve clearance	I	I	I	I	I	I
Engine oil	R	R	R	R	R	R
Tightening nuts and bolts	I	I	I	I	I	I
Clutch wear	I	R	I	R	I	R
Labour time in hours	14	14,5	17,5	14,5	14	18

By using the P.A.D.S. diagnostic tool (which must be updated to the latest available version), the new, dedicated engine calibration designed specifically for the version in question may be used to **monitor the effective technological stress level of the mechanical components for use on the racetrack.**



For this reason, **when the general warning lamp (see figure) remains on in the steady state for more than 2 seconds**, every 120 seconds, users should contact their local Authorised Aprilia Service Centre in order to arrange for the specific maintenance procedure to be carried out, as indicated in the table.

Connect the diagnostic tool, select parameters and states, and check that the equivalent track kilometres correspond to 6,000 km, or a multiple thereof

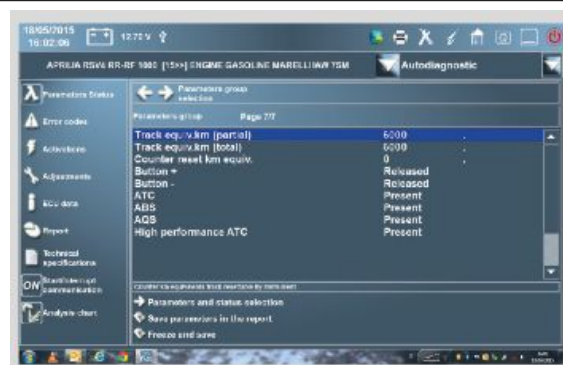

Upon completing the specific track maintenance procedure, access the "adjustments" section of the diagnostic tool **and reset the equivalent kilometres, so that it is possible to extinguish the "warning lamp" and carry out the calculation for the next service.**

The "Equivalent KM reset counter" will be increased by one.

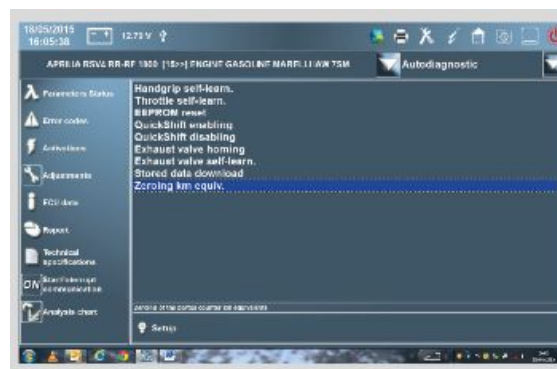

Recommended products

TABLE OF RECOMMENDED PRODUCTS

Product	Description	Specifications
Engine oil 5W -40	Synthetic-based lubricant for four-stroke engines.	SAE 5W-40; JASO MA, MA2; API SL; ACEA A3
Lithium-based grease	Lithium-calcium soap based grease	colour - black, contains EP (Extreme Pressure) additives, excellent water-repellent properties
Anti-freeze liquid, ready to use, colour red	Ethylene glycol antifreeze liquid with organic inhibition additives. Red, ready to use.	ASTM D 3306 - ASTM D 4656 - ASTM D 4985 - CUNA NC 956-16
Brake fluid DOT 4	Synthetic brake fluid.	SAE J 1703; FMVSS 116; ISO 4925; CUNA NC 956 DOT4
Öhlins 5W	Öhlins fork oil.	Application - RSV4 1000 RF forks; SAE 5W
Hydraulic fluid HVI 32	Fork oil	Application - Sachs RSV4 1000 RR forks; ISO-L-HV

Spark plug

FRONT SPARK PLUGS

- Remove the base of the air filter box.
- Undo and remove the screw.



- Slide off the front coil.



- Unscrew and remove the front spark plug.

REAR SPARK PLUGS

- Remove the fuel tank.
- Unscrew and remove the rear coil fastener screw.
- Slide off the rear coil.
- Unscrew and slide off the rear spark plug.



Engine oil

Check



THE OIL LEVEL MUST BE CHECKED WHEN THE ENGINE IS WARM.

CAUTION

DO NOT LET THE ENGINE IDLE WITH THE VEHICLE AT A STANDSTILL TO WARM UP THE ENGINE AND OBTAIN THE OPERATING TEMPERATURE OF ENGINE OIL. PREFERABLY CHECK THE OIL AFTER A JOURNEY OF AFTER TRAVELLING APPROXIMATELY 15 Km (10 miles) IN EXTRA-URBAN CONDITIONS (ENOUGH TO WARM UP THE ENGINE OIL TO OPERATING TEMPERATURE).

- Shut off the engine and wait a few seconds.
- Keep the vehicle upright with both wheels on the earth
- Ensure that you are on a flat surface
- Unscrew the engine oil level dipstick (1)

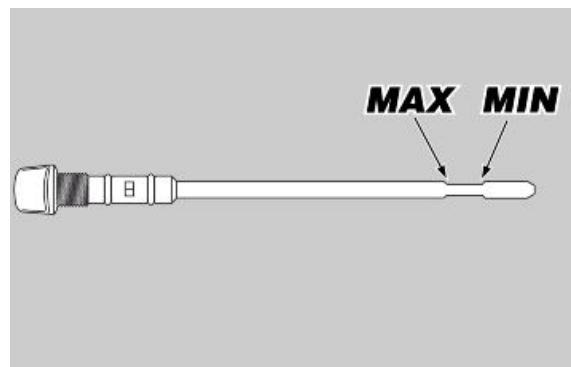

- Clean the engine oil level dipstick (1) and put it back in without screwing it in
- Remove it again and check the engine oil level
- The level is correct if it reaches the "MAX" level approximately. Otherwise top off the engine oil

**CAUTION**

THE OIL LEVEL MUST NEVER DROP BELOW THE MINIMUM MARKING OR EXCEED THE MAXIMUM MARKING; AN OIL LEVEL NOT WITHIN THE MINIMUM AND MAXIMUM MARKINGS MAY CAUSE SEVERE ENGINE DAMAGE

Replacement

NOTE

HOT OIL IS MORE FLUID AND WILL DRAIN OUT MORE EASILY AND COMPLETELY.

- Place a container with suitable capacity under the drainage plug.
- Unscrew and remove the drainage plug.



- Unscrew and remove the filler cap.
- Drain the oil into the container; allow several minutes for oil to drain out completely.
- Check and, if necessary, replace the drainage plug sealing washers.
- Screw and tighten the drainage plug.
- Add 4 l (0.88 UK gal) of new engine oil of the specified type.
- Screw on the filler cap.

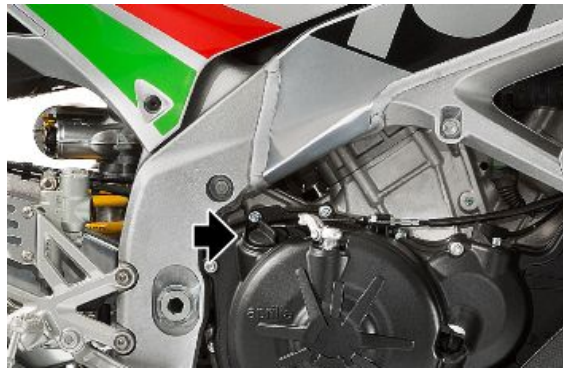

- Warm up the engine up by running it for a few minutes, then switch it off. After thirty seconds, check the level with a oil level dipstick. Top up if necessary.

CAUTION

THE OIL LEVEL MUST NEVER DROP BELOW THE MINIMUM MARKING OR EXCEED THE MAXIMUM MARKING; AN OIL LEVEL NOT WITHIN THE MINIMUM AND MAXIMUM MARKINGS MAY CAUSE SEVERE ENGINE DAMAGE

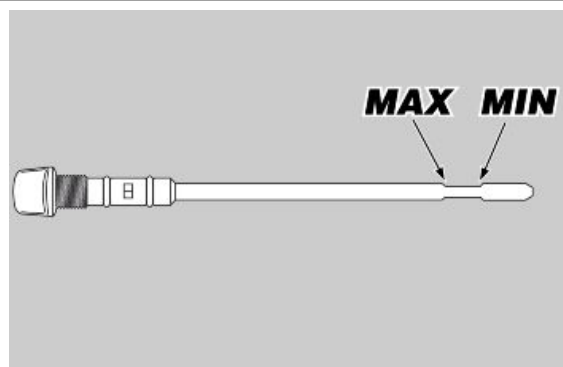
**Verifica parastrappi**

- Operating from the left side of the motorcycle, using a torque wrench, check and if necessary tighten the nuts fixing the crown to the support to the prescribed torque



Engine oil filter

Replace the engine oil filter each time you change the engine oil.

- Drain the engine oil completely.
- Unscrew and remove the engine oil filter from its seat.

NOTE

NEVER REUSE AN OLD FILTER.



- Spread a thin layer of oil on the sealing ring of the new engine oil filter.
- Insert and screw the new engine oil filter in the seat, filling the filter to 1/3 of its capacity with engine oil before fitting.

See also

[Replacement](#)

Air filter

- Remove the fuel tank.
- Unscrew and remove the eight air filter box cover screws.

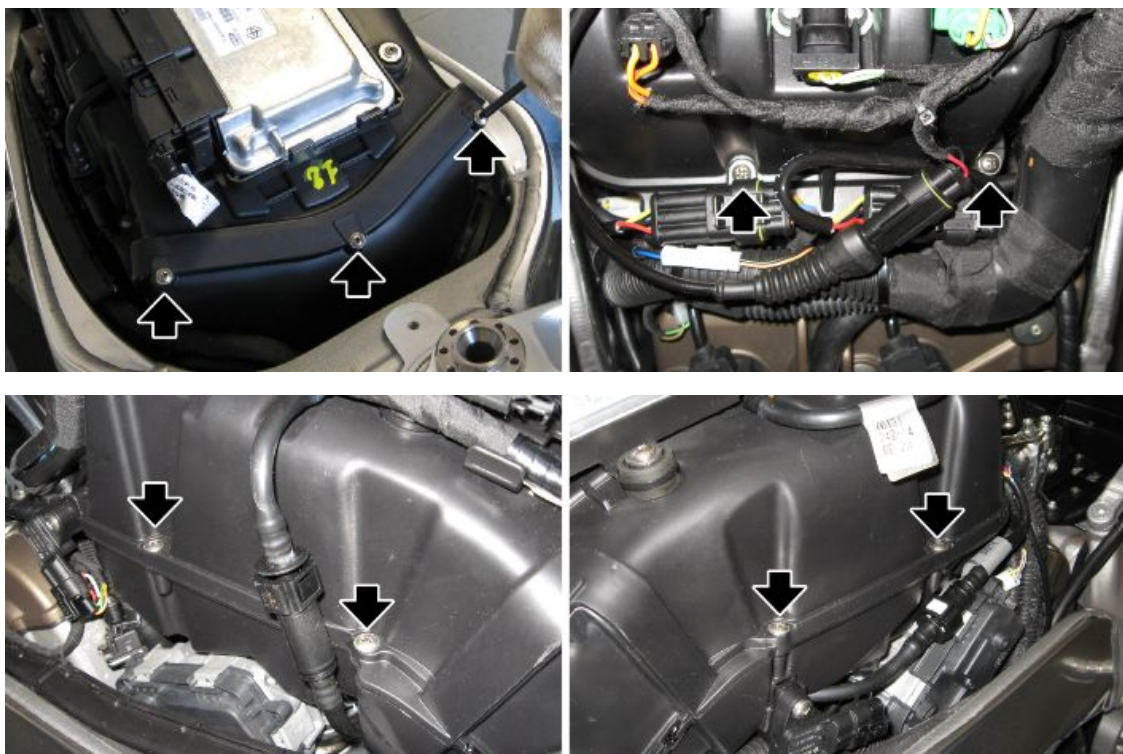

- Disconnect the upper injector fuel delivery union.



- Lift the filter box cover on which the control unit is installed.
- Do not rotate the cover excessively to avoid straining the pipes and cables.



- Remove the air filter.



Checking the valve clearance

FRONT HEAD

- Remove both throttle bodies and the coils.
- Remove the front head cover and the spark plugs.
- Remove the sound-proofing cover from the clutch side.
- Remove the cap on the clutch cover in order to turn the crankshaft, taking care not to lose the O-ring.



- Turn the crankshaft from the hole on the clutch cover until the valves are not in tension.

- Use a feeler gauge to check the clearance between the cam of the shaft and the relative tappet for both front head shafts.



Characteristic

Acceptable values with control clearance between cam and valve

intake: 0.10 - 0.15 mm (0.0039 - 0.0059 in) ex-

haust: 0.20 - 0.25 mm (0.0079 - 0.0098 in)

REAR CYLINDER HEAD

- Remove both throttle bodies and the spark plugs.
- Remove the rear head cover.

- Use a feeler gauge to check the clearance between the cam on the shaft and the relative tappet for both rear head shafts.



Characteristic

Acceptable values with control clearance between cam and valve

intake: 0.10 - 0.15 mm (0.0039 - 0.0059 in) ex-

haust: 0.20 - 0.25 mm (0.0079 - 0.0098 in)

Front cylinder head valves

- Check the play on the front head valves and, if it is necessary to restore the correct play values, proceed as follows.

- Remove both the head covers, the sound-proofing covers, the alternator side cover and clutch cover cap so that it is possible to rotate the crankshaft.
- Remove the O-ring.



- Rotate the crankshaft via the opening on the clutch cover.

- Position cylinder 1 piston (LH, rear piston) so that it is at the point where it crosses TDC.
- rotate the crankshaft 150° in the engine rotation direction (direction of travel).

- insert the respective pin, from the fly-wheel side, into the groove on the crankshaft.

NOTE

THE SPECIAL TOOL SHOWN HERE MUST ONLY BE USED FOR IDENTIFYING THE CORRECT POSITION OF THE CRANKSHAFT. DO NOT USE IT FOR TIGHTENING COMPONENTS.

Specific tooling**020852Y Crankshaft timing pin**

- Fit the pin for aligning the intake camshaft with the hole on U-bolt.
- If it was not possible before adjusting the valve clearance, check the engine timing.

Specific tooling**020851Y Camshaft timing pin**

- Remove the two crankshaft and camshaft reference pins.
- Turn the crankshaft until the gear screw covered by the head when the hole on the camshaft gear is aligned with the hole on the U bolt, is visible.
- Block crankshaft rotation using one of the specific tools.
- Unscrew and remove the camshaft gear screw.
- Remove the crankshaft locking tool.

Specific tooling**020850Y Primary gear lock****020914Y Flywheel retainer**

Repeat the following operations:

- move cylinder piston 1 (left rear piston) to TDC;
- turn the crankshaft 150° in the direction of engine rotation (direction of travel) in order to align the hole on the intake camshaft with the specific hole on the U bolt; this ensures that all the front cylinder bank valve springs are decompressed.
- Refit the camshaft timing setting pin in the hole in the U bolt on the front head, and refit the crankshaft timing pin from the flywheel side, to check that the timing setting was not altered while the engine was turned with only one camshaft drive gear fastener screw in place.
- Remove the camshaft timing pin.
- Unscrew and remove the three screws (1).
- Remove the U bolt (2) and the oil pipe (3).

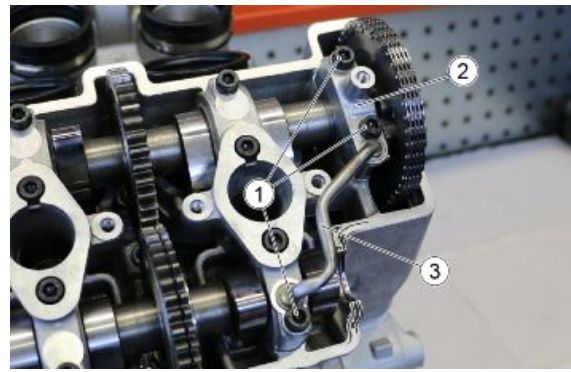

Specific tooling

020851Y Camshaft timing pin

020852Y Crankshaft timing pin

- Block crankshaft rotation using one of the specific tools.
- Unscrew and remove the second intake camshaft gear screw.
- Leave the gear on the camshaft.

Specific tooling

020850Y Primary gear lock

020914Y Flywheel retainer



- Install the specific camshaft gear support tool.
- Fix it to the head using the two screws (1).

Specific tooling

020956Y Support for camshaft gear on head

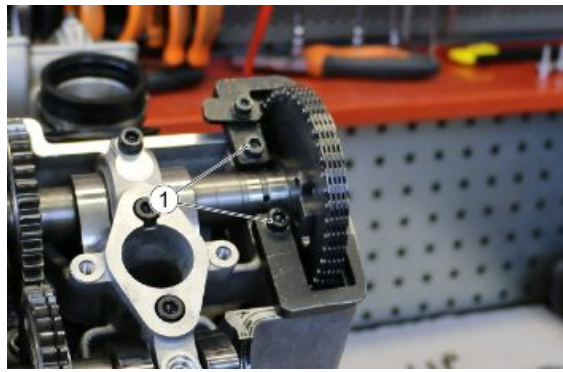

- Move the gear from the camshaft to the tool and make sure that it is locked by fastening the tool's spacer.

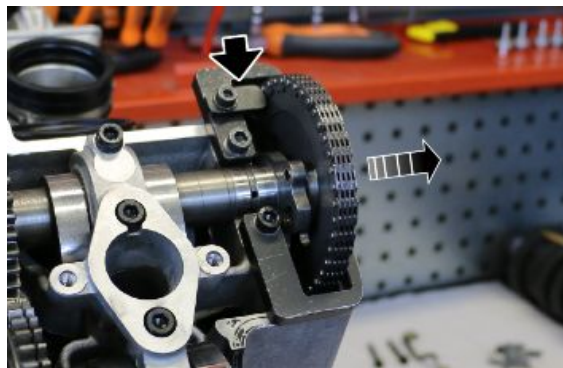

- Unscrew and remove the seven screws (4), proceeding in stages and diagonally.
- Retrieve the washers from the screws near the spark plug holes.
- Remove the U bolts with the O rings and locator pins.

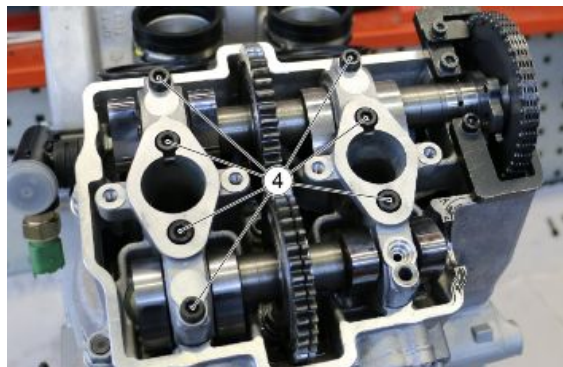

- Remove the intake and exhaust camshafts.

If the two camshafts are timed correctly, the exhaust camshaft gear tooth (indicated with a dot) is meshed with the trough of the intake camshaft gear (indicated with two dots).

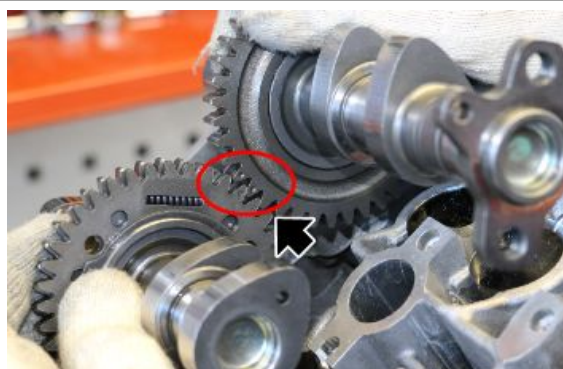

- Use a magnet to remove the tappet.

CAUTION

REMOVE THE TAPPET CAREFULLY AS THE PAD MAY FALL INTO THE ENGINE.

- Retrieve the pad and replace with a suitable component to achieve the correct valve clearance.

Refer to the table: "Calibrated pad thicknesses" to identify the suitable thickness.

- Fit the tappet.



See also

[Calibrated pad thickness](#)

- Loosen the distribution gear's lock screw and move the gear itself from the mounting tool to the camshaft.
- Unscrew and remove the two screws (1).
- Remove the tool.

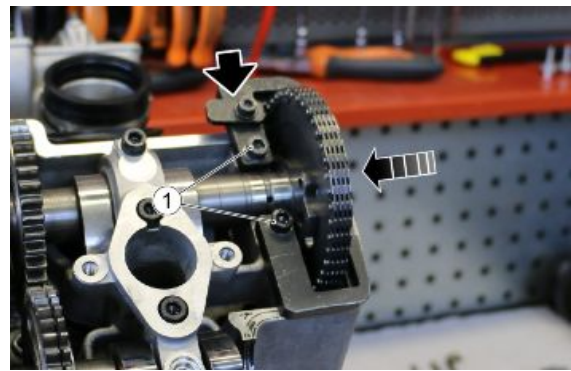

- Position the U bolt (2) and the oil pipe (3).
- Insert the two screws (1).
- Tighten all the U bolts' screws working in stages and diagonally.

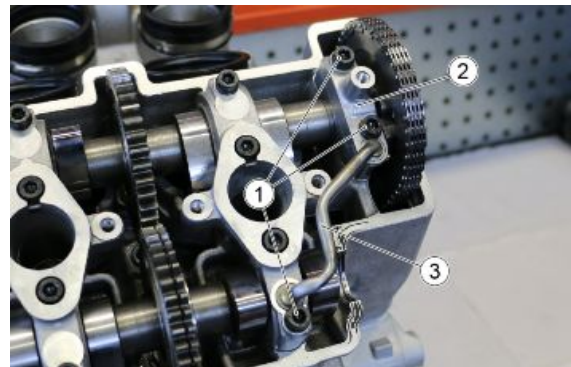

- Align the intake camshaft with the specific hole on the U bolt.
- Insert the specified pin.

Specific tooling

020851Y Camshaft timing pin



- Apply Loctite 243 thread lock on the thread of the timing gear fastener screw. This screw must be replaced at each reassembly.
- Apply and loosely tighten the gear fixing screw on the camshaft.



- Block crankshaft rotation using one of the specific tools.
- Tighten the gear fixing screw on the camshaft to exactly the torque specified.
- Remove the crankshaft locking tool.



Specific tooling

020850Y Primary gear lock

020914Y Flywheel retainer

- Remove the two crankshaft and camshaft reference pins.
- Turn the crankshaft until the gear screw covered by the head when the hole on the camshaft gear is aligned with the hole on the U bolt, is visible.
- Block crankshaft rotation using one of the specific tools.
- Apply Loctite 243 thread lock on the thread of the second gear fastener screw. This screw must be replaced at each reassembly.
- Tighten the second camshaft gear fixing screw to exactly the torque specified.
- Remove the crankshaft locking tool.
- Turn the crankshaft back to the previous position in which the camshaft and U bolt holes were aligned; insert the reference pin while checking with the crankshaft reference pin, that the flywheel side hole and the hole on the crankshaft are perfectly aligned.
- If this is not the case, repeat the timing operations.

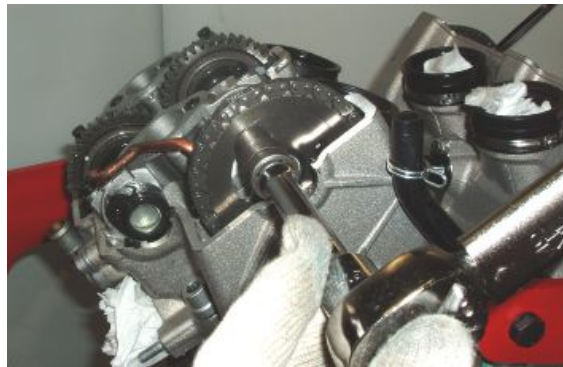

Specific tooling

020851Y Camshaft timing pin

020852Y Crankshaft timing pin

- Check if the clearance between the cam on the shaft and the tappet is correct.
- If not, repeat the valve clearance adjustment procedure.

Rear cylinder head valves

- Check the rear valve head clearance and restore the correct clearance values if necessary, proceeding as described below.
- Remove the rear head cover and the clutch cover.
- Move cylinder piston 1 (left rear piston) to the TDC;
- Turn the crankshaft 450° (one complete turn + 90°) in the direction of motor rotation (direction of travel).

- Insert the pin from the clutch side into the hole in the crankshaft.

NOTE

THE SPECIAL TOOL SHOWN HERE MUST ONLY BE USED FOR IDENTIFYING THE CORRECT POSITION OF THE CRANKSHAFT. DO NOT USE IT FOR TIGHTENING COMPONENTS.

Specific tooling

020852Y Crankshaft timing pin



- Fit the pin for aligning the intake camshaft with the hole on U-bolt.
- If it was not possible before adjusting the valve clearance, check the engine timing.

Specific tooling

020851Y Camshaft timing pin



- Remove the two crankshaft and camshaft reference pins.
- Turn the crankshaft until the gear screw covered by the head when the hole on the camshaft gear is aligned with the hole on the U bolt, is visible.
- Block crankshaft rotation using one of the specific tools.
- Unscrew and remove the camshaft gear screw.
- Remove the crankshaft locking tool.



Specific tooling

020850Y Primary gear lock

020914Y Flywheel retainer

Repeat the following operations:

- Move cylinder piston 1 (left rear piston) to TDC;
- Turn the crankshaft by 450° (one complete turn + 90°) in the direction of the engine's rotation (direction of travel) to align the hole on the intake camshaft with the specific hole on the U bolt; This ensures that all the rear cylinder bank valve springs are decompressed.
- Refit the camshaft timing setting pin in the hole in the U bolt on the rear head, and refit the crankshaft timing pin from the clutch side, to check that the timing setting was not altered while the engine was turned with only one camshaft drive gear fastener screw in place.
- Remove the camshaft timing pin.
- Unscrew and remove the two screws (1) from the U bolt (2).
- Remove the U bolt (2) and the oil pipe (3).

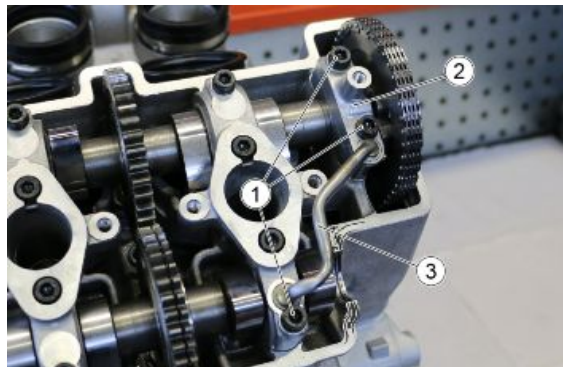

Specific tooling**020851Y Camshaft timing pin****020852Y Crankshaft timing pin**

- Block crankshaft rotation using one of the specific tools.
- Unscrew and remove the second intake camshaft gear screw.
- Leave the gear on the camshaft.

**Specific tooling****020850Y Primary gear lock****020914Y Flywheel retainer**

- Install the specific camshaft gear support tool.
- Fix it to the head using the two screws (1).

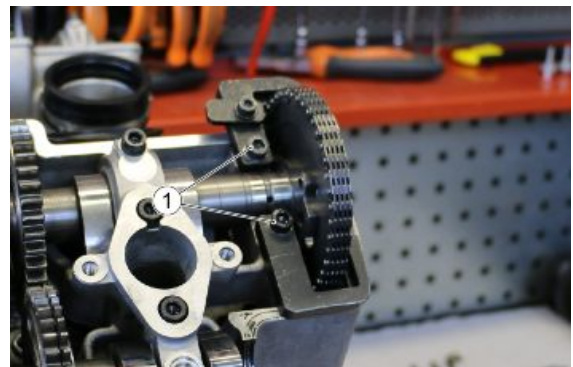
**Specific tooling****020956Y Support for camshaft gear on head**

- Move the gear from the camshaft to the tool and make sure that it is locked by fastening the tool's spacer.

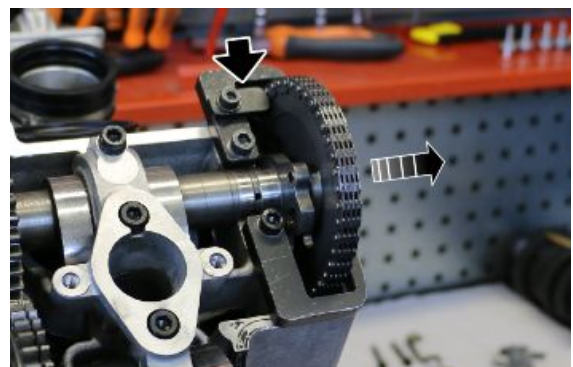

- Unscrew and remove the seven screws (4), proceeding in stages and diagonally.
- Retrieve the washers from the screws near the spark plug holes.
- Remove the U bolts with the O rings and locator pins.

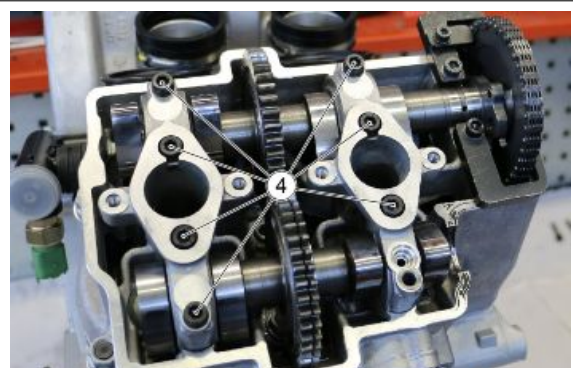

- Remove the intake and exhaust camshafts.

If the two camshafts are timed correctly, the intake camshaft gear tooth (indicated with one dot) is meshed with the trough of the exhaust camshaft gear (indicated with two dots).

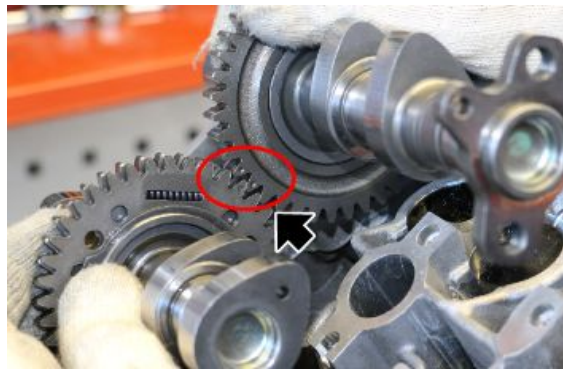

- Use a magnet to remove the tappet.

CAUTION

REMOVE THE TAPPET CAREFULLY AS THE PAD MAY FALL INTO THE ENGINE.

- Retrieve the pad and replace with a suitable component to achieve the correct valve clearance.

Refer to the table: "Calibrated pad thicknesses" to identify the suitable thickness.

- Fit the tappet.



NOTE

THIS ENGINE HAS CAMSHAFTS OF THE EXHAUST VALVES WITH CLEARANCE RECOVERY.

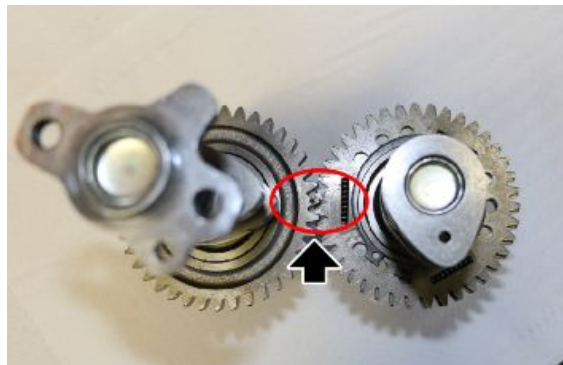

- Install the intake and exhaust camshafts on the rear head, remembering that: the intake camshaft gear tooth (indicated with a dot) is inserted in the groove of the exhaust camshaft gear (indicated with two dots).



CLEAN THOROUGHLY THE SEATS OF THE GEAR RETAINER SCREWS, ON THE INTAKE CAMSHAFT.

- Fit the U bolts with nine O rings and locator pins.
- Position the screws (4), taking care to insert new washers on the screws near the spark plug holes.

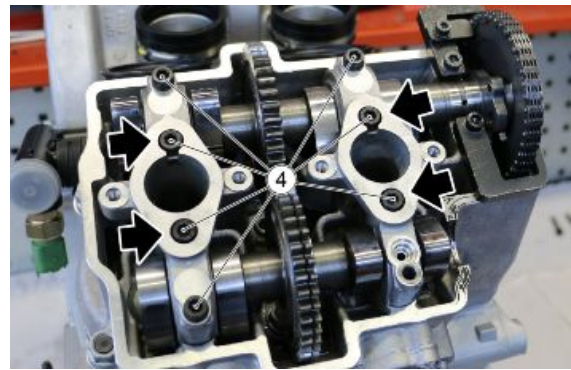

- Loosen the distribution gear's lock screw and move the gear itself from the mounting tool to the camshaft.
- Unscrew and remove the two screws (1).
- Remove the tool.

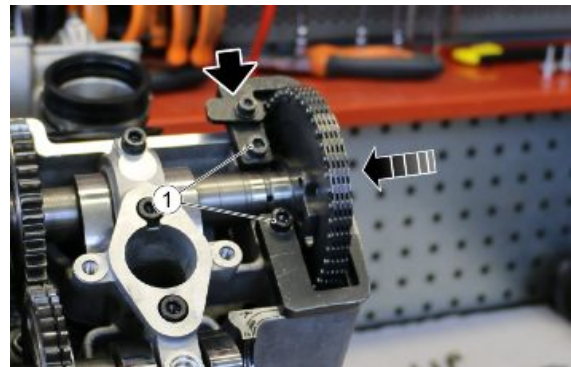

- Position the U bolt (2) and the oil pipe (3).
- Insert the two screws (1).
- Tighten all the U bolts' screws working in stages and diagonally.

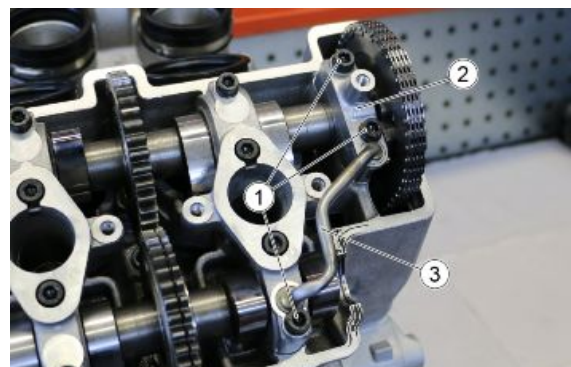

- Align the intake camshaft with the specific hole on the U bolt.
- Insert the specified pin.

Specific tooling

020851Y Camshaft timing pin



- Apply Loctite 243 thread lock on the thread of the timing gear fastener screw. This screw must be replaced at each reassembly.
- Apply and loosely tighten the gear fixing screw on the camshaft.



- Block crankshaft rotation using one of the specific tools.
- Tighten the gear fixing screw on the camshaft to exactly the torque specified.
- Remove the crankshaft locking tool.



Specific tooling

020850Y Primary gear lock

020914Y Flywheel retainer

- Remove the two crankshaft and camshaft reference pins.
- Turn the crankshaft until the gear screw covered by the head when the hole on the camshaft gear is aligned with the hole on the U bolt, is visible.
- Block crankshaft rotation using one of the specific tools.
- Apply Loctite 243 thread lock on the thread of the second gear fastener screw. This screw must be replaced at each reassembly.
- Tighten the second camshaft gear fixing screw to exactly the torque specified.
- Remove the crankshaft locking tool.
- Turn the crankshaft back to the previous position in which the camshaft and U bolt holes were aligned; Refit the reference pin while checking, using the crankshaft reference pin, that the clutch side hole and the hole in the crankshaft are perfectly aligned.
- If this is not the case, repeat the timing operations.



Specific tooling**020851Y Camshaft timing pin****020852Y Crankshaft timing pin**

- Check if the clearance between the cam on the shaft and the tappet is correct.
- If not, repeat the valve clearance adjustment procedure.

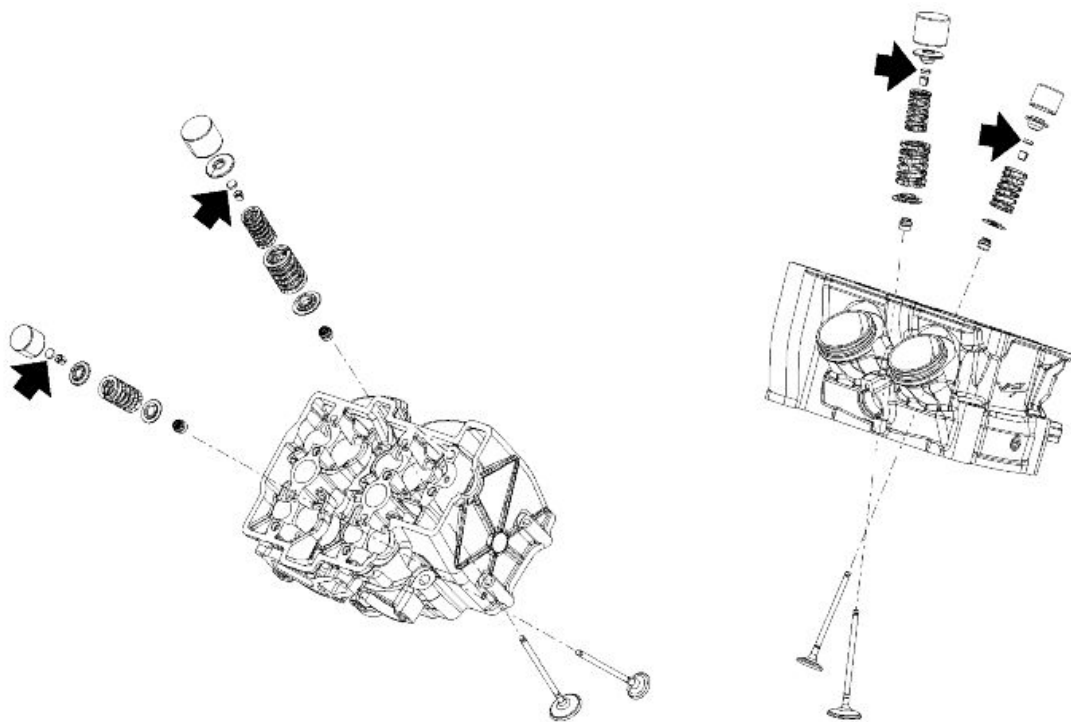
Calibrated pad thickness

Pad thicknesses for adjusting valve clearance correctly:

- 1.75 mm (0.0689 in)
- 1.77 mm (0.0697 in)
- 1.80 mm (0.0709 in)
- 1.82 mm (0.0716 in)
- 1.85 mm (0.0728 in)
- 1.87 mm (0.0736 in)
- 1.90 mm (0.0748 in)
- 1.92 mm (0.0756 in)
- 1.95 mm (0.0768 in)
- 1.97 mm (0.0775 in)
- 2 mm (0.0787 in)
- 2.02 mm (0.0795 in)
- 2.05 mm (0.0807 in)
- 2.07 mm (0.0815 in)

2.1 mm (0.0827 in)
2.12 mm (0.0835 in)
2.15 mm (0.0846 in)
2.17 mm (0.0854 in)
2.2 mm (0.0866 in)
2.22 mm (0.0874 in)
2.25 mm (0.0886 in)
2.27 mm (0.0894 in)
2.3 mm (0.0905 in)
2.32 mm (0.0913 in)
2.35 mm (0.0925 in)
2.37 mm (0.0933 in)
2.4 mm (0.0945 in)
2.42 mm (0.0953 in)
2.45 mm (0.0964 in)
2.47 mm (0.0972 in)
2.50 mm (0.0984 in)
2.52 mm (0.0992 in)
2.55 mm (0.1004 in)
2.57 mm (0.1012 in)
2.6 mm (0.1024 in)
2.62 mm (0.1031 in)
2.65 mm (0.1043 in)
2.67 mm (0.1051 in)
2.7 mm (0.1063 in)
2.72 mm (0.1071 in)
2.75 mm (0.1083 in)
2.77 mm (0.1090 in)
2.8 mm (0.1102 in)
2.82 mm (0.1110 in)
2.85 mm (0.1122 in)
2.87 mm (0.1129 in)
2.9 mm (0.1142 in)
2.92 mm (0.1150 in)
2.95 mm (0.1161 in)
2.97 mm (0.1169 in)
3 mm (0.1181 in)
3.02 mm (0.1189 in)

3.05 mm (0.1201 in)

3.07 mm (0.1209 in)

3.10 mm (0.1220 in)

3.12 mm (0.1228 in)

3.15 mm (0.1240 in)

INDEX OF TOPICS

ELECTRICAL SYSTEM

ELE SYS

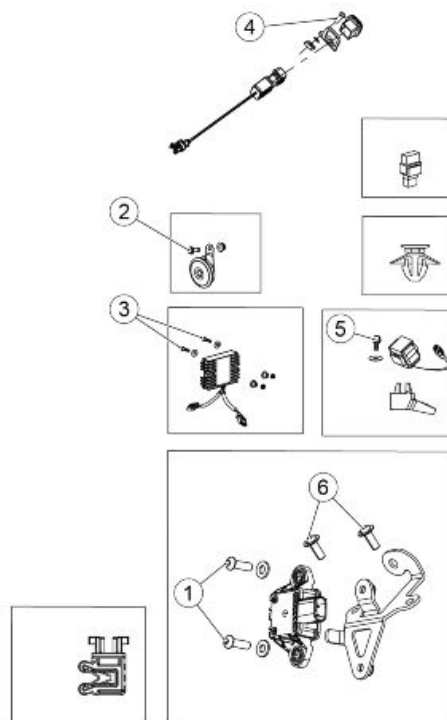

FRONT ELECTRICAL SYSTEM

Pos.	Description	Type	Quantity	Torque	Notes
1	Flanged button head hex socket screws for fastening the sensor to the bracket	M6x12	2	6 Nm (4.43 lb ft)	-
2	Horn fixing screw	M8	1	15 Nm (11.06 lb ft)	-
3	Button head, hex. socket voltage regulator fixing screws	M6x30	2	6 Nm (4.43 lb ft)	-
4	Button head, hex socket screws for fastening the USB port bracket (if fitted)	-	1	6 Nm (4.43 lb ft)	-
5	Flanged button head hex socket screws for fastening the sensor to the bracket	M6x12	2	6 Nm (4.43 lb ft)	-

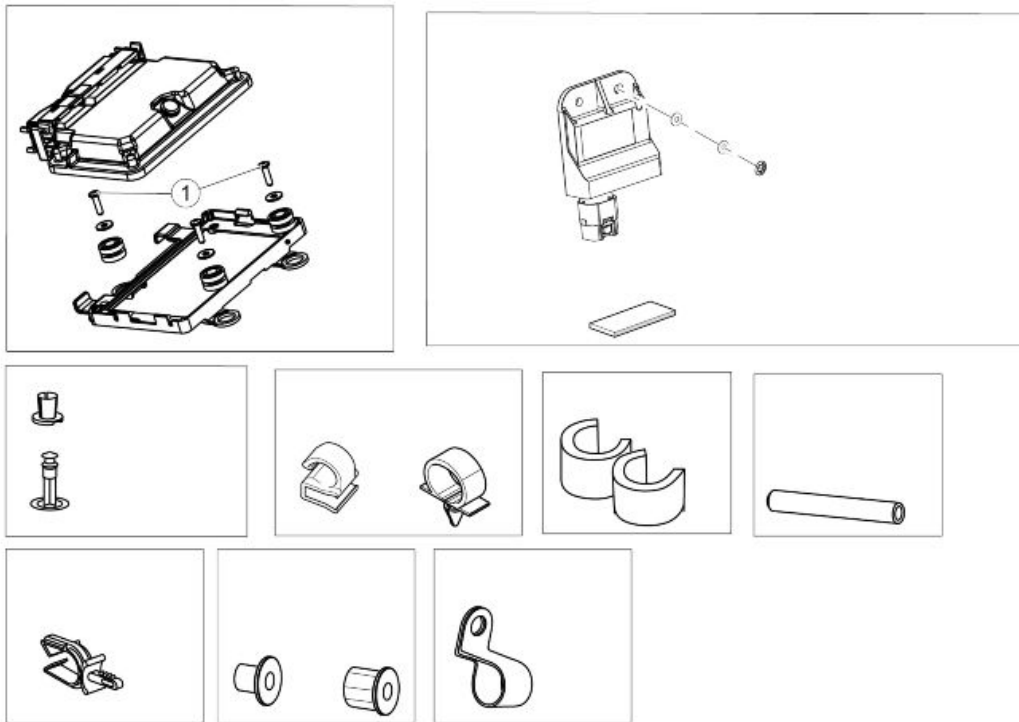

CENTRAL ELECTRICAL SYSTEM

Pos.	Description	Type	Quantity	Torque	Notes
-	Starter relay cables fastening screws	M5	2	4 Nm (2.95 lb ft)	-

Components arrangement

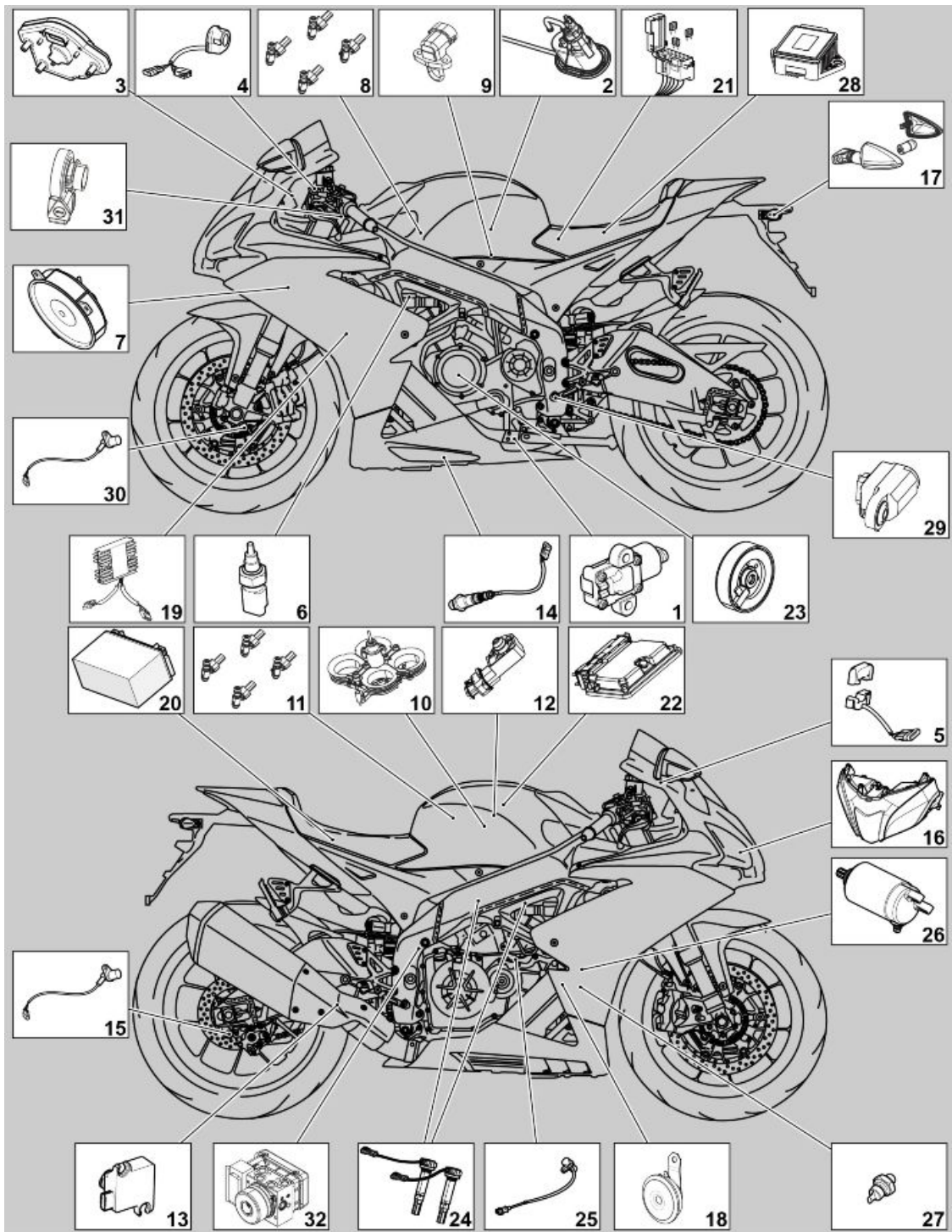

Key:

- 1. Side stand sensor.
- 2. Fuel pump
- 3. Instrument panel
- 4. Left hand switch

5. Right hand switch
6. Water temperature sensor
7. Cooling fans
8. Upper injectors
9. Air temperature sensor
10. Intake ducts
11. Lower injectors
12. Air pressure sensor
13. Exhaust valve
14. Lambda probe
15. Engine speed sensor
16. Headlamp
17. Rear turn indicators
18. Horn
19. Voltage regulator
20. Battery
21. Secondary fuses
22. Electronic control unit
23. Alternator
24. Coils
25. Timing sensor
26. Starter motor
27. Oil pressure sensor
28. Inertia platform
29. Quick Shift
30. Front tone wheel sensor
31. a-PRC commands
32. ABS control unit



THE IDENTIFICATION OF THE RELAY CANNOT BE CARRIED OUT JUST ON THE BASIS OF THE INDICATIONS BELOW: IN ANY EVENT IT SHOULD OCCUR WITH THE IDENTIFICATION OF THE COLOUR OF THE RELAY CABLES.

RELAY LAYOUT

Location of the component in the electrical circuit diagram	Component name	Position on the vehicle:
10	Low beam lights relay	Front part of the top fairing
9	High beam lights relay	Front part of the top fairing
31	Start-up relay	Under rear tail fairing
20	Protection relay	Under the saddle near the battery, left side

Location of the component in the electrical circuit diagram	Component name	Position on the vehicle:
33	Injection relay	Under the saddle near the battery, right side
36	Fan control relay	In the headstock niche, on the left
25	Recovery logic relay (urgent service)	In the headstock niche, on the right

Electrical system installation

Scope and applicability

The purpose of this document is to define the correct cable harness routing layout to ensure the reliability of the vehicle.

Materials used and corresponding quantities

The electrical system consists of the following wiring harnesses and parts:

- 1 x Vehicle wiring harness
- 1 x Headlamp wiring harness
- 1 x Number plate holder wiring harness
- 1 x Positive Battery Cable
- 1 x Engine-Battery Earth Cable
- 1 x Ignition switch
- 2 x ABS speed sensors
- 1 x Starter relay
- 5 x Relays
- 1 x Safety relay
- 1 x Horn
- 1 x Front Headlight
- 1 x Rear Headlight
- 1 x Instrument Cluster
- 1 x RH Rear-view Mirror with Dir. Ind.
- 1 x LH Rear-view Mirror with Dir. Ind.
- 1 x RH Rear Direction Indicator (LED)
- 1 x LH Rear Direction Indicator (LED)
- 1 x Fuel Pump Unit
- 1 x Side-stand Switch
- 1 x Exhaust Valve Actuator
- 2 x Oxygen sensors (Lambda Probes)
- 2 x fans
- 1 x Regulator
- 1 x Demand Sensor (built into the throttle handle)
- 1 x YT12A-BS Battery

- 1 x SensorBox
- 1 x QuickShift
- 1 x V4-MP Control Unit (if present)

Small parts and mountings

- 9 x Large black 290x4 clamps
- 8 x Small black 160x2.5 clamps
- 1 x Rubber clamp
- 1 x Flanged M6x16 hex. head screw
- 1 x Flanged M6x15 screw
- 2 x M5x8 screws
- 2 x Cable glands
- 2 x W cable glands
- 4 x Cable guides
- 5 x Relay holder grommets
- 3 x Supports for AMP Superseal connectors
- 1 x Battery (YT12A-BS) support bracket
- 2 x Clamps
- 2 x Edge Clamps
- 2 x Spring clips
- 2 x Spring clips (regulator connector)

Motorcycle division

The wiring harnesses on the vehicle are subdivided into three main sections, as indicated in the figure.

1. Front section
2. Central section
3. Rear section



Special checks for the correct connection and routing of cables

It is extremely important that any security-locks for the following connectors are properly connected and correctly tightened to ensure proper engine, and therefore proper vehicle, operation.

- Sponge connector on licence plate holder light.
- Check the ECU control unit connection
- Check the side stand connection.
- Check the quick shift cables retaining clamp.
- Check that the engine oil cap is correctly inserted.

- Check the ground fastening on the starter motor, starter motor positive and relative hood.
- Check the taillight connection.
- Check the connection between the number plate holder wiring harness and the main wiring harness.
- Check the fuel pump connection.
- Check the regulator connection.
- Check fastening of the chassis - engine ground cable.
- Check the Flywheel-Regulator connection.
- Check the Lambda connection (Front Rear).
- Check that the Lambda probe cable is routed correctly (Front Rear).
- Check that the "ABS" connector is inserted correctly (Front Rear).
- Check that the "ABS" sensors are correctly connected (Front and Rear).
- Check that the RH and LH fan connector is connected correctly.
- Check the injection relay connection (with diode).
- Check that the cables on the starter relay are connected correctly and the torque cable fastening screws are tightened correctly.
- Check the rear stop switch connection.
- Check that the R&W connector is connected and routed correctly.
- Check the RH and LH rear indicator connections.
- Check the gear connector connection.
- Check the quick shift connector connection.
- Check that all the connectors inside the instrument support arch have been connected correctly.

CAUTION

THE CONNECTORS INDICATED IN THE LIST ARE CIRCLED IN GREEN IN THE VARIOUS PHOTOS THESE CONNECTORS HAVE BEEN LISTED AS THEY ARE MORE CRITICAL THAN OTHERS, AND THEIR DISCONNECTION MAY CAUSE VEHICLE BREAKDOWN OR MALFUNCTION. NATURALLY, IT IS ALSO NECESSARY THAT ALL OTHER CONNECTORS CONNECTED CORRECTLY TO ENSURE THAT THE VEHICLE FUNCTIONS CORRECTLY. THE INSTRUCTIONS FOR ROUTING AND FASTENING THE WIRING HARNESS THROUGHOUT THE VEHICLE MUST BE FOLLOWED PRECISELY TO ENSURE THAT THE VEHICLE FUNCTIONS CORRECTLY AND RELIABLY.

Front side

WIRING TABLE A - RELAY SENSOR SUPPORT

(A)

PRE-ASSEMBLY

Position the relays in their rubber grommets and pre-assemble them on the support.

1. Relay
2. Relay grommets
3. Support

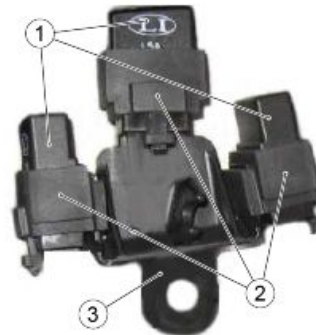

WIRING TABLE B - REGULATOR PRE-ASSEMBLY

(B)

1. Regulator
2. Regulator connector
3. Flywheel connector
4. Self-locking nut (x2)
5. T-shaped bushing (x2)
6. M6x30 button head hex socket screws (x2)
7. Washer (x2)

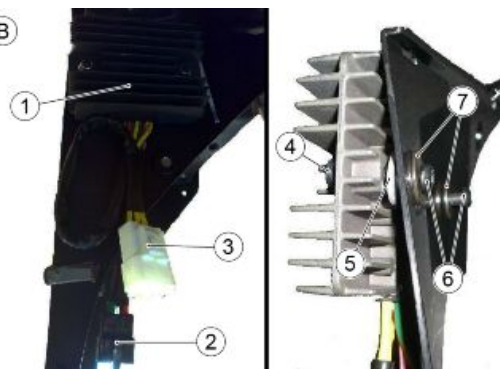

WIRING TABLE C - FRONT HEADLIGHT PRE-ASSEMBLY

(C)

The front headlight wiring must be pre-assembled on the headlight by means of a clamp

1. Headlamp wiring harness
2. Small black clamp



WIRING TABLE C1 - FRONT HEADLIGHT PRE-ASSEMBLY

(C1)

1. Headlamp
2. Relay
3. Cable grommet
4. Small black clamp



WIRING TABLE D - PRE-ASSEMBLING THE LIGHT SWITCH

1. LH light switch wiring harness

- 2. Traction control commands wiring harness
- 3. Clutch switch wiring harness
- 4. RH light switch wiring harness
- 5. Ride By Wire control wiring harness

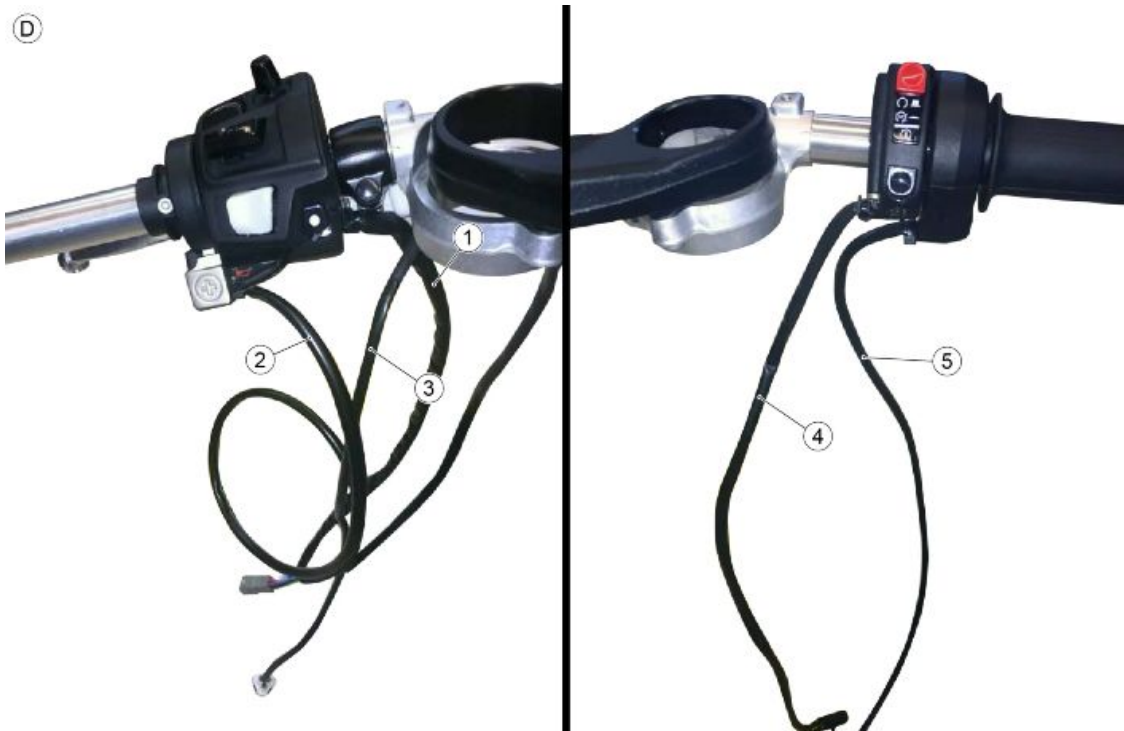

WIRING TABLE E - INSTRUMENT SUPPORT ARCH AND FRONT PART

Position the two clamps as indicated



WIRING TABLE E1 - INSTRUMENT SUPPORT ARCH AND FRONT PART

Using the first edge clamp, secure the light switch wiring harness, making a note of its length (taking into account the movement of the handlebar) first.

- 1. RH light switch wiring harness.

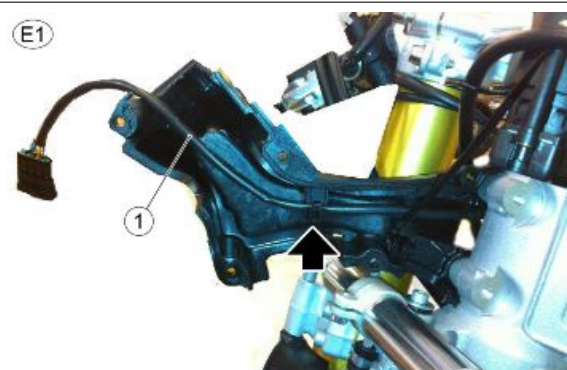

WIRING TABLE E2 - INSTRUMENT SUPPORT ARCH AND FRONT PART

Position the main wiring harness and secure it to the right hand instrument holder support using a grey reference clamp

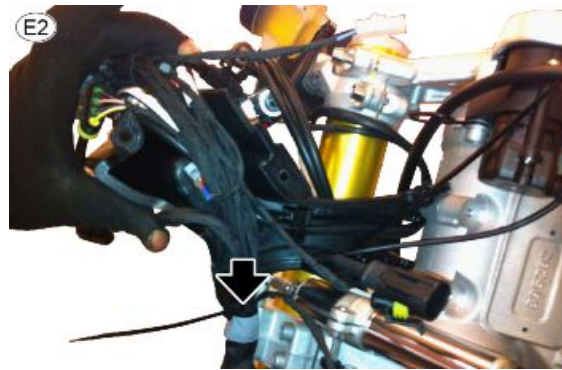

WIRING TABLE E3 - INSTRUMENT SUPPORT ARCH AND FRONT PART

Using the second pre-installed clamp on the instrument support arch, group together all the cables from the left hand side of the handlebar, and fasten them together, making a note of their respective lengths first



WIRING TABLE E4 - INSTRUMENT SUPPORT ARCH AND FRONT PART

Cable output on right hand side of the instrument support

1. RH light switch wiring harness

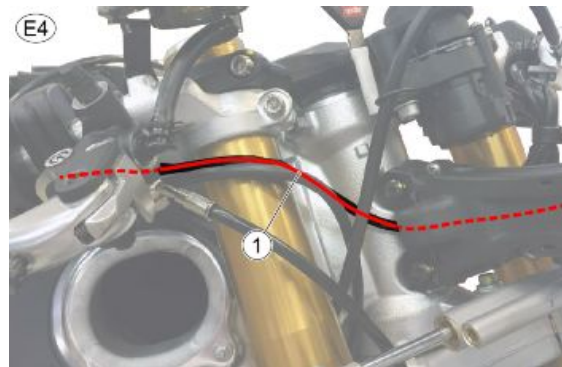

WIRING TABLE E5 - INSTRUMENT SUPPORT ARCH AND FRONT PART

Cable output on left hand side of the instrument support

1. LH light switch wiring harness;
2. Clutch switch wiring harness;
3. Traction control commands wiring harness.

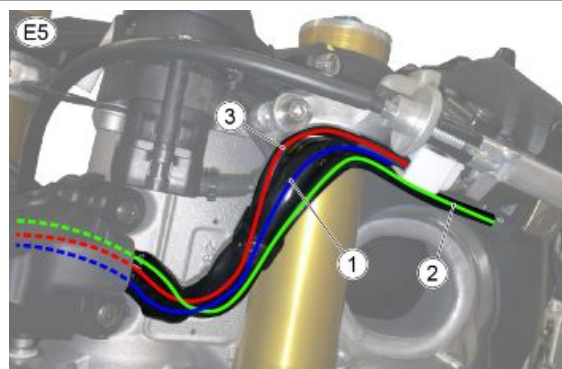

WIRING TABLE E6 - INSTRUMENT SUPPORT ARCH AND FRONT PART

Insert the connectors in their housings on the arch

1. Left turn indicator connector
2. Right hand turn signal connector

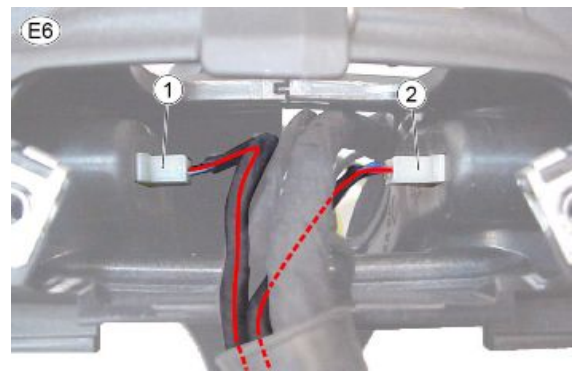

WIRING TABLE F - FRONT WHEEL ABS SENSOR PASSAGE (OHLINS FORKS)

1. ABS sensor
2. Cable grommet

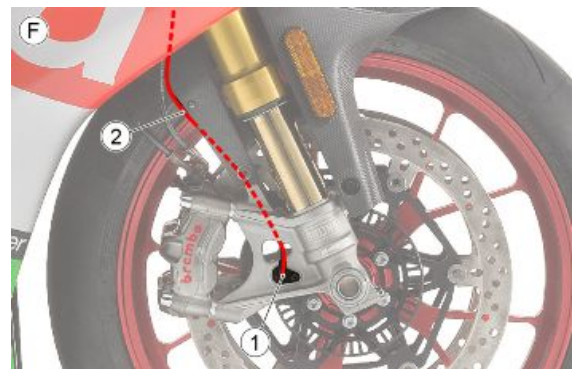

WIRING TABLE F1 - FRONT WHEEL ABS SENSOR PASSAGE (SACHS FORK)

1. ABS sensor
2. Cable guide
3. Clamp
4. Cable grommet

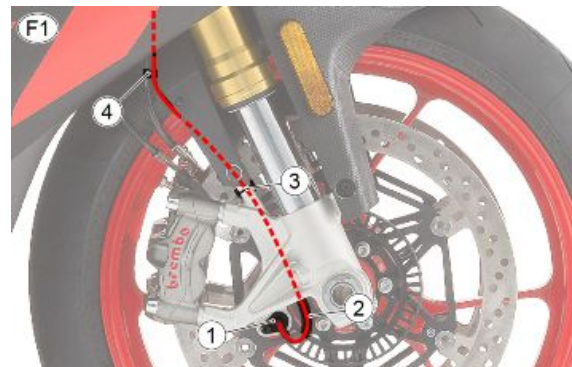

WIRING TABLE F2 - FRONT ABS SENSOR WIRING

Wherever possible, maintain the ABS sensor wiring as externally as possible.

- Clamp the ABS sensor wiring to the main wiring loom.
- Using a small clamp (1), secure the ABS sensor wiring to the radiator.

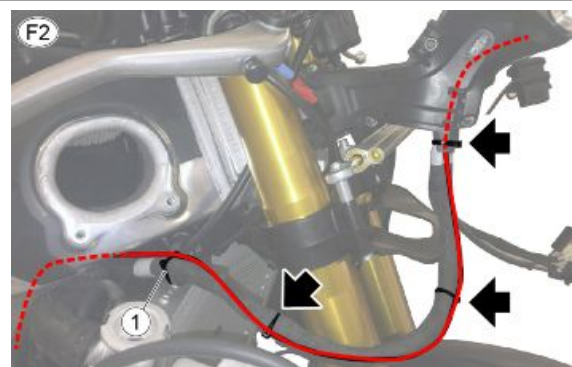

WIRING TABLE F3 - FRONT ABS SENSOR**WIRING**

Check that the front ABS sensor connector is connected correctly and positioned inside the instrument support arch together with all the other connectors present in that area.

**WIRING TABLE G - COMPLETING THE FRONT MUDGUARD ASSEMBLY**

Position the front headlight connectors under the instrument support arch

**WIRING TABLE G - COMPLETING THE FRONT MUDGUARD ASSEMBLY**

Check that the indicator connectors are inserted correctly and that they do not protrude into the instrument holder arch

1. Right hand turn signal connector
2. Left turn indicator connector

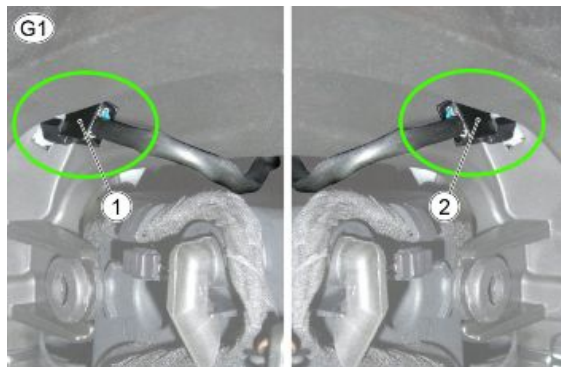

WIRING TABLE H - USB PORT (IF FITTED)

The USB port wiring harness must be routed behind instrument cluster and the port must be fastened by means of the support bracket.



Central part

TABLE A - IGNITION RELAY PRE-ASSEMBLY

The positive battery cable must be connected to the hole identified by the letter B (Battery) using M5x8 screw

1. Start-up relay
2. Battery positive cable pole (identified by the letter "B")
3. Vehicle wiring starter motor cable pole (identified by the letter "M")

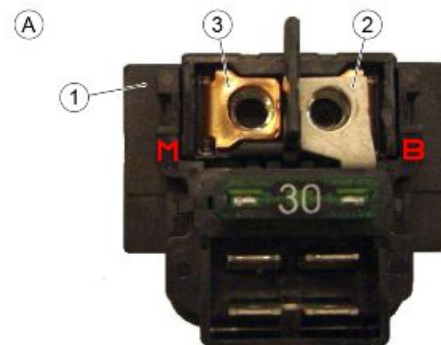

TABLE A1 - IGNITION RELAY PRE-ASSEMBLY

If the battery positive cable is not connected to the ignition relay correctly it may result in fires and incorrect vehicle operation.

1. Ignition relay
2. Battery positive cable

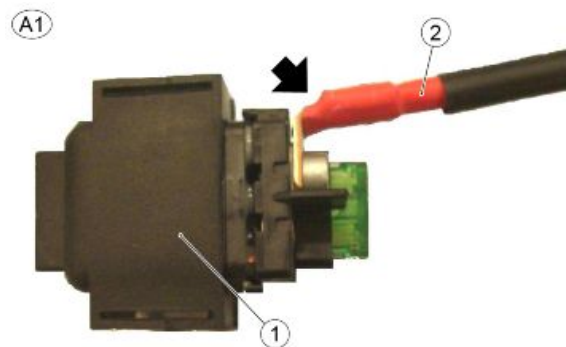
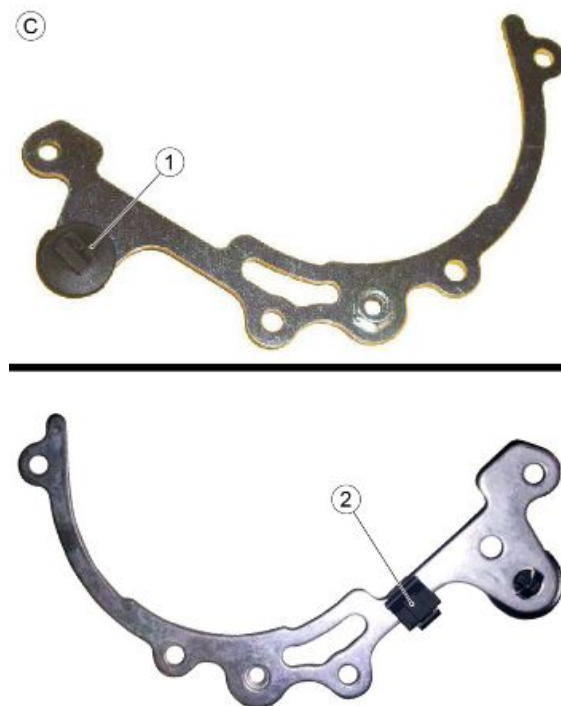

TABLE B - FUEL TANK PRE-ASSEMBLY

- Position the SENSOR BOX (1) on its support bracket (2), which is fixed to the fuel tank.

**TABLE C - PINION GUARD PRE-ASSEMBLY**

- Position the support (1) for the lambda probe connector and the quick shift wiring cable guide (2) on the pinion protection guard.



WIRING TABLE D - VEHICLE WIRING HARNESS

Position the main wiring harness inside the conduits and close them using the two clamps

**WIRING TABLE D1 - VEHICLE WIRING HARNESS**

Secure the conduit to the frame at the four points indicated and fasten in using the central screws (1).

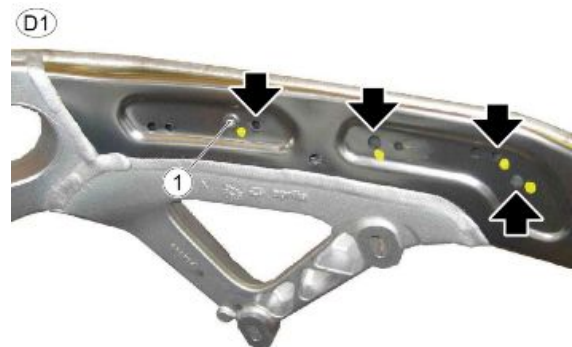
**WIRING TABLE D2 - VEHICLE WIRING HARNESS**

Secure the main wiring harness (1) using the cable glands (2) at the points indicated by the grey taping present on the harness itself.

Secure the relay support to the frame that the: safety relay (3), injection relay (4) and fans relay (5) are attached to.

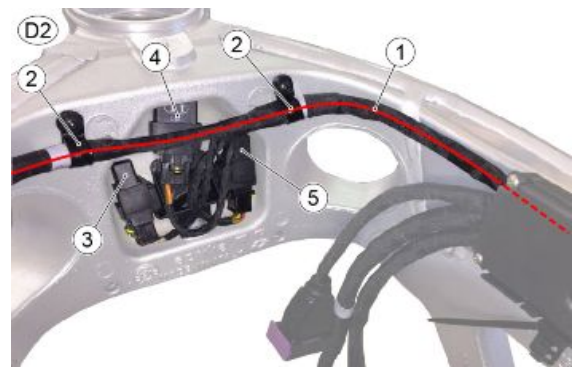
**WIRING TABLE D3 - VEHICLE WIRING HARNESS**

Secure the main wiring harness (1) using the clamp (2) at the point indicated by the grey taping present on the harness itself.

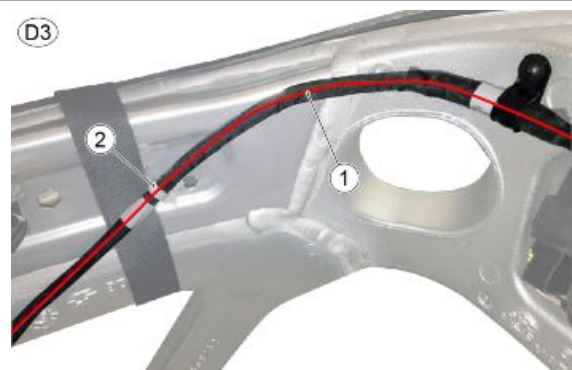

WIRING TABLE E - STARTER MOTOR AND OIL BULB ZONE

1. Earth wiring routing (behind the water pipe and starter motor)
2. Starter motor wiring harness routing (behind the water pipe)
3. Starter motor lug

COVER THE STARTER MOTOR NUT AND THE SQUARE TERMINAL WITH DI-ELECTRIC, WATER-REPELLENT GREASE

4. Oil pressure sensor wiring harness routing (behind the water pipe)
5. Oil pressure sensor

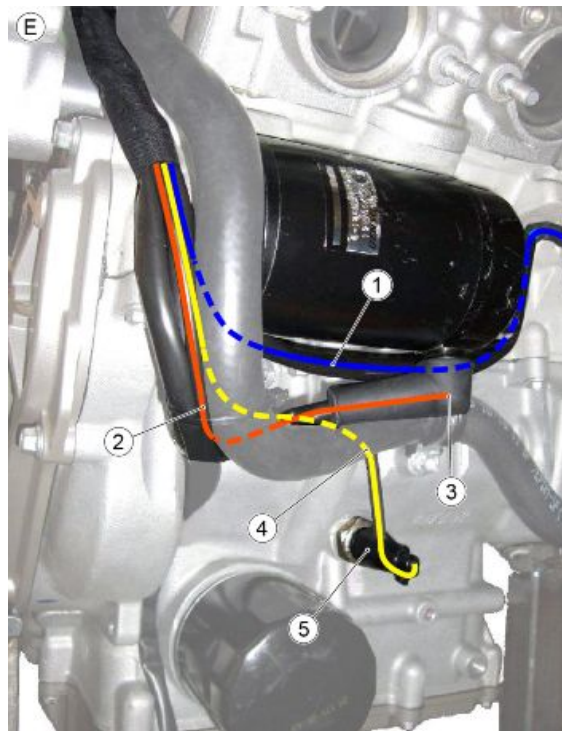

WIRING TABLE E1 - STARTER MOTOR AND OIL BULB ZONE

IF THE RELAY-STARTER MOTOR CABLE IS NOT ROUTED AND/OR SECURED CORRECTLY IT MAY CAUSE THE VEHICLE TO CATCH FIRE. CHECK THAT THE CABLE ON THE STARTER MOTOR IS POSITIONED AS INDICATED IN THE FIGURE



WIRING TABLE E2 - STARTER MOTOR AND OIL BULB ZONE

Check that the terminal is connected and that the hood is inserted in the bulb correctly. using a clamp, bend the leg of the cap by 180 ° and secure the wiring.



WIRING TABLE F - INTERCONNECTION BETWEEN ENGINE WIRING HARNESS AND MAIN WIRING HARNESS

Check that the connectors have been connected correctly and that the purple slide is in the end stop position

1. Vehicle connector
2. Engine connector

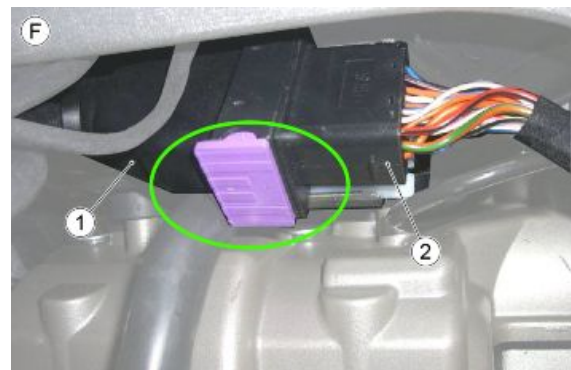

WIRING TABLE G - VEHICLE EARTH CABLE

Battery-engine earth cable routing

The battery-engine earth cable must not be visible in the zone indicated by the red triangle symbol

1. Large clamp (clamp the battery-engine earth wiring to the demand sensor wiring as high up as possible)
2. Engine-battery earth cable

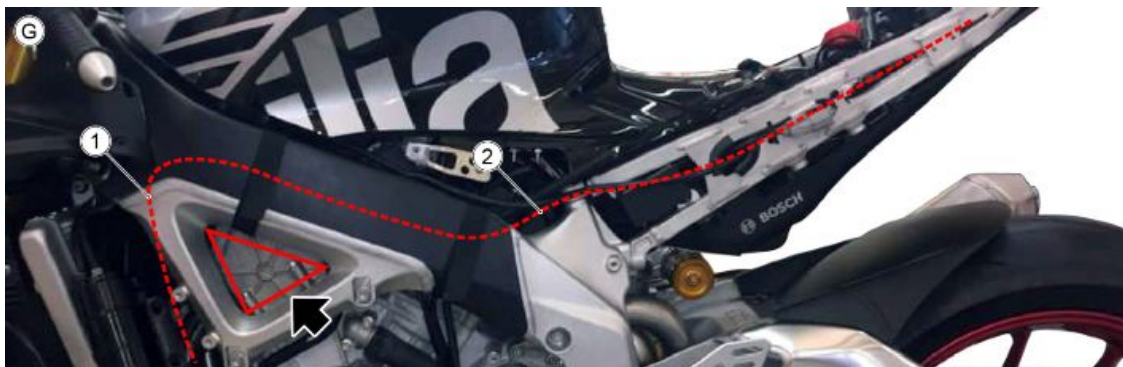

WIRING TABLE H - ENGINE EARTH CABLE IF THE SCREWS (1) USED TO SECURE THE EARTH CABLES ARE NOT FASTENED CORRECTLY IT MAY CAUSE THE VEHICLE TO CATCH FIRE.

2. ENGINE EARTH lug from vehicle wiring harness
3. ENGINE EARTH lug from engine wiring harness
4. ENGINE EARTH lug from battery-engine earth cable

TAKE CARE NOT INVERT THE "FRAME EARTH LUG FROM ENGINE WIRING HARNESS" AND THE "BATTERY-ENGINE EARTH CABLE ENGINE EARTH LUG "

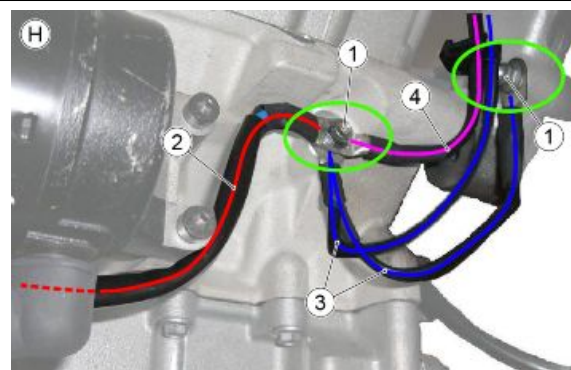

WIRING TABLE H1 - LH SIDE ZONE

using a large clamp (1), secure the voltage regulator (2) wiring to the water radiator.

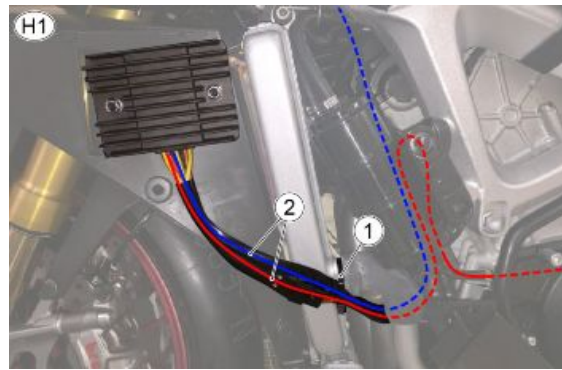
**WIRING TABLE H2 - LH SIDE ZONE**

1. Small clamp.
2. Large clamp (must be large enough to clamp the hand-wheel cable, the regulator cable and the front lambda probe cable together).

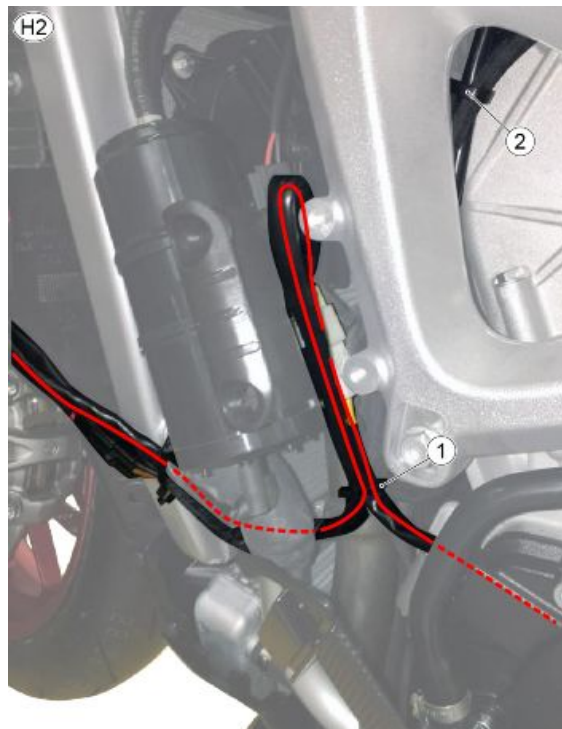

WIRING TABLE H3 - LH SIDE ZONE

The fan (1) and flywheel-regulator (2) connectors must be connected correctly and attached to their respective supports on the canister.

**WIRING TABLE I - EXHAUST VALVE MOTOR ZONE**

1. Ride by wire wiring harness;
2. RH fan wiring harness;
3. Exhaust valve motor wiring harness;
4. Exhaust valve;
5. Small clamp;
6. Vehicle wiring harness;
7. Cable grommet.

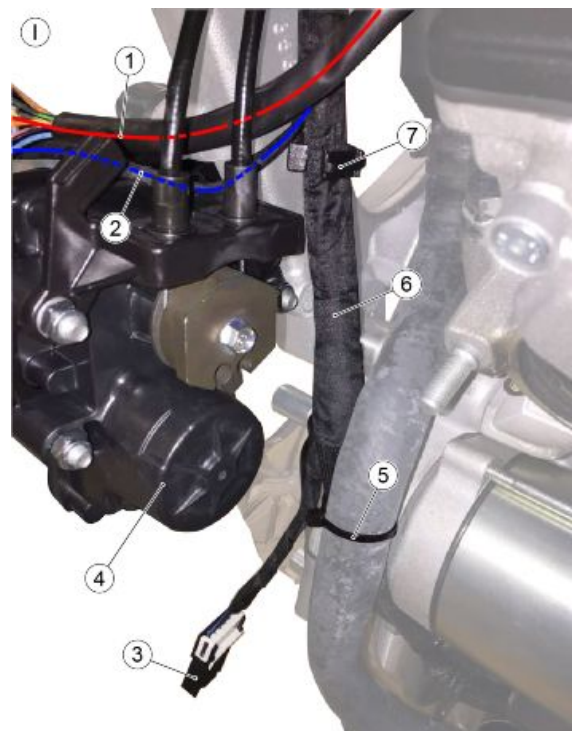

WIRING TABLE I - EXHAUST VALVE MOTOR ZONE

The fan (1) and ride by wire (2) wiring harnesses must be routed between the frame and the exhaust valve cables.

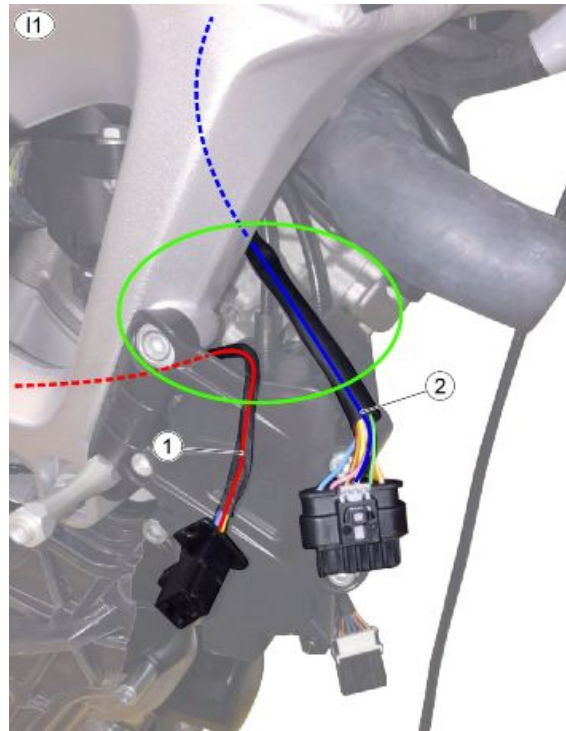
**WIRING TABLE I - EXHAUST VALVE MOTOR ZONE**

The fan (1) and ride by wire (2) wiring harness connectors must be connected correctly and attached to the exhaust valve support.

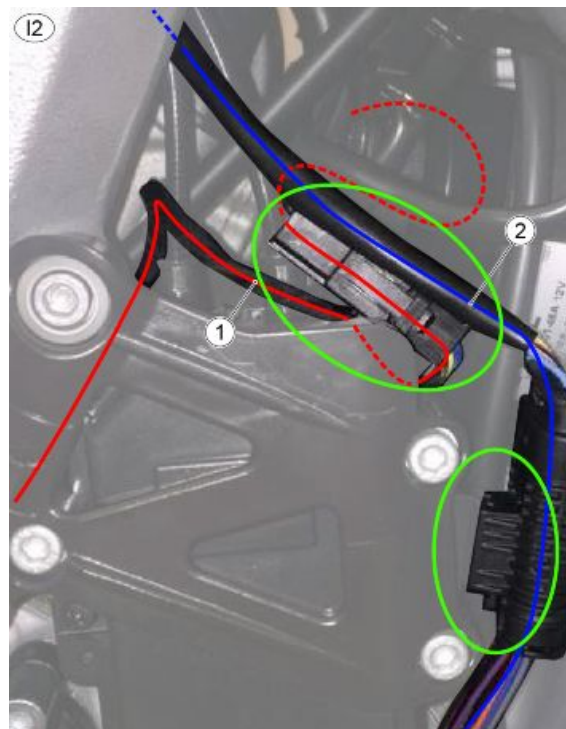

WIRING TABLE I - EXHAUST VALVE MOTOR ZONE

The fan wiring harness (1) must be fastened to the ride by wire control wiring harness (2) by a clamp (3).

Check that the grey safety lock (4) on the ride by wire control connector, is locked in the lowered position.

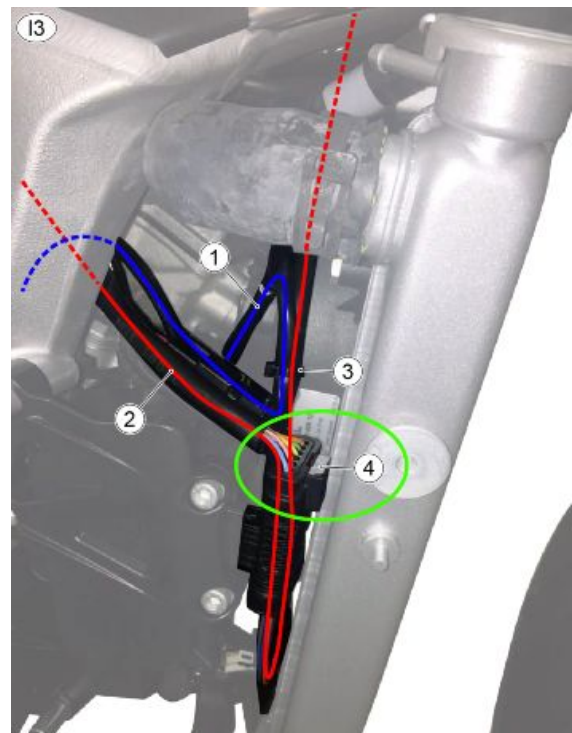

WIRING TABLE L - RIDE BY WIRE CONTROL WIRING HARNESS

The ride by wire control wiring harness (1) must be routed above the arm of the main wiring harness (2) that branches towards the instrument cluster and below the radiator hose (3), which connects the thermostatic valve to the radiator.

CAUTION



IF THE RIDE BY WIRE CONTROL WIRING HARNESS IS NOT ROUTED CORRECTLY IT MAY DAMAGE THE CONTROL.

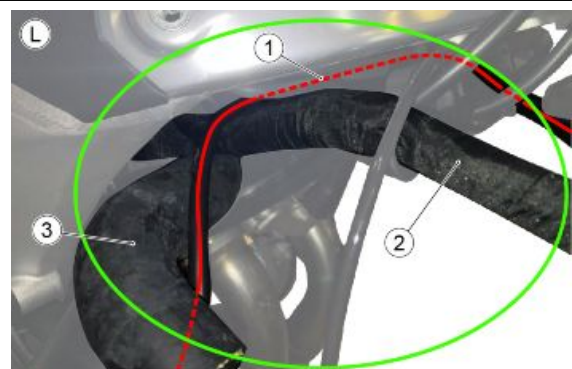

WIRING TABLE L1 - RIDE BY WIRE CONTROL WIRING HARNESS

The ride-by-wire control wiring (1) must be routed externally with respect to the thermostatic valve (2).

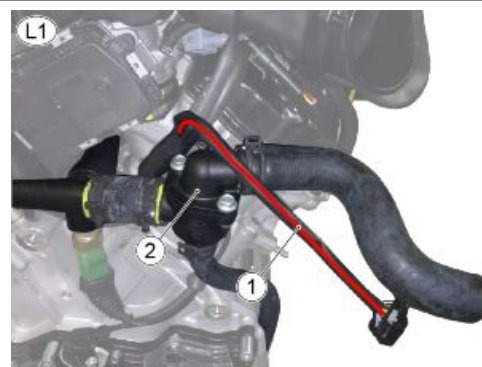

WIRING TABLE M - PINION ZONE

The quick shift wiring (1) must be routed through the cable guide (2) that has been pre-assembled on the pinion guard

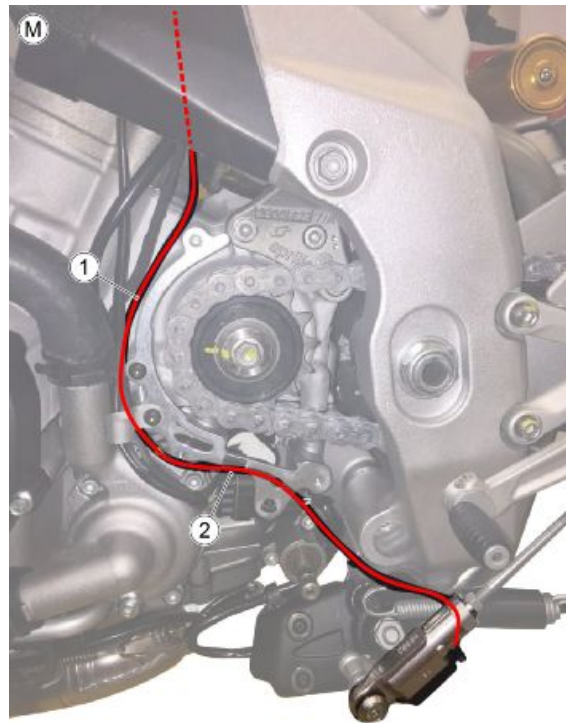
**WIRING TABLE M1 - PINION GUARD ZONE**

1. Side stand switch
2. Cable grommet
3. Side stand switch wiring harness

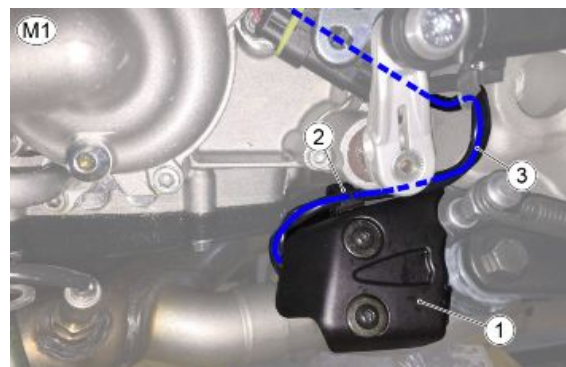
**WIRING TABLE M2 - PINION GUARD ZONE**

ROUTE THE WIRING BEHIND THE CABLE GLAND USED TO CLOSE THE TWO FUEL BREATHER TUBES

1. Quick Shift wiring harness routing
2. Rear lambda probe wiring harness routing
3. Gear sensor wiring harness routing
4. Side stand switch wiring harness routing

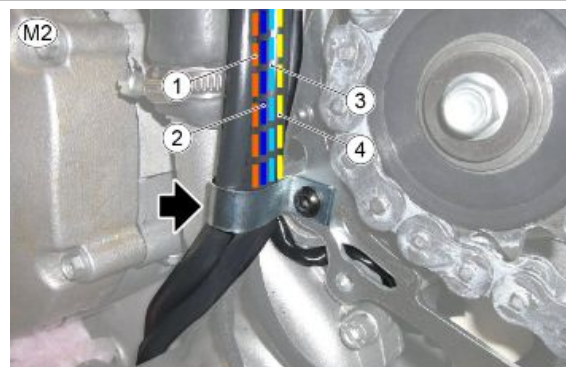

WIRING TABLE N - LAMBDA PROBES

1. Rear lambda probe wiring harness routing

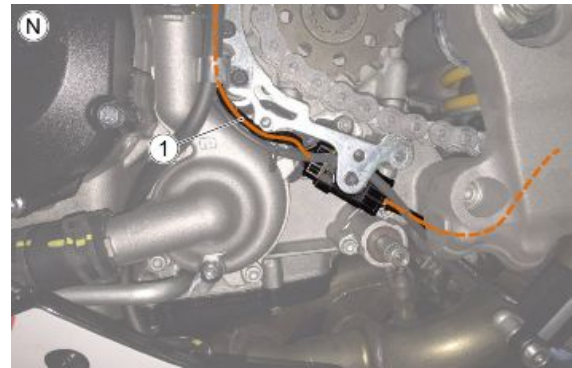
**WIRING TABLE N1 - LAMBDA PROBES**

THE CABLE GLAND MUST BE POSITIONED TOWARDS THE TOP AND LAMBDA SENSOR CABLE MUST BE ROUTED THROUGH IT



WIRING TABLE N2 - LAMBDA PROBES

CHECK THAT THE FRONT LAMBDA PROBE CONNECTOR HAS BEEN CONNECTED CORRECTLY

1. Front lambda probe wiring harness routing

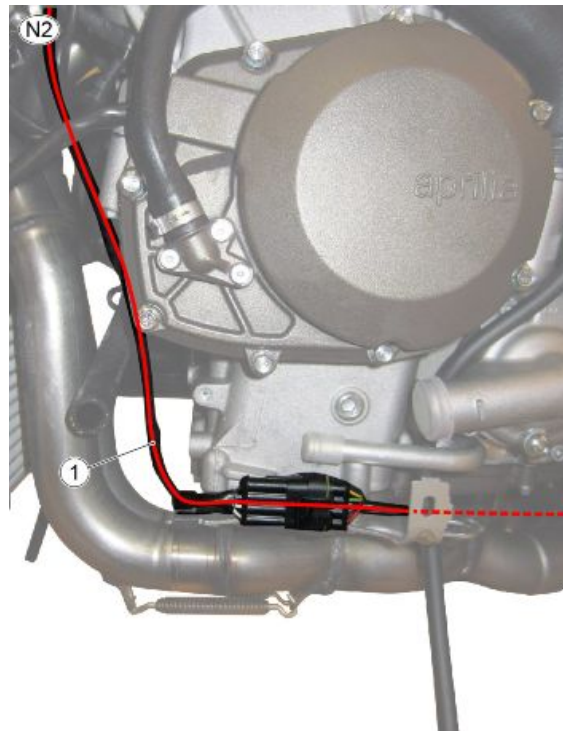
**WIRING TABLE N3 - LAMBDA PROBES**

1. Front lambda probe cable from main wiring harness
 2. Front lambda probe cable to probe
- Route the lambda probe cable through the cable gland (3) and attach the connector to the support (4) on the bracket.

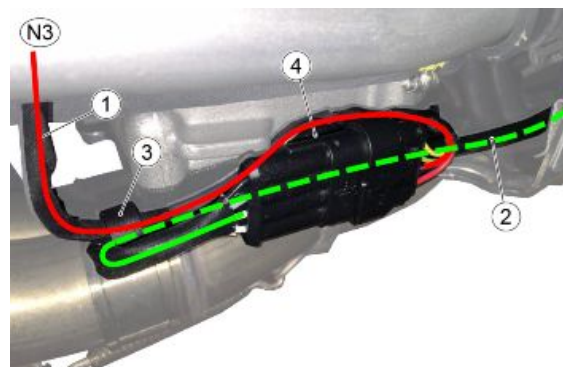
**WIRING TABLE N4 - LAMBDA PROBES**

1. Lambda probe cable in front of breather tubes

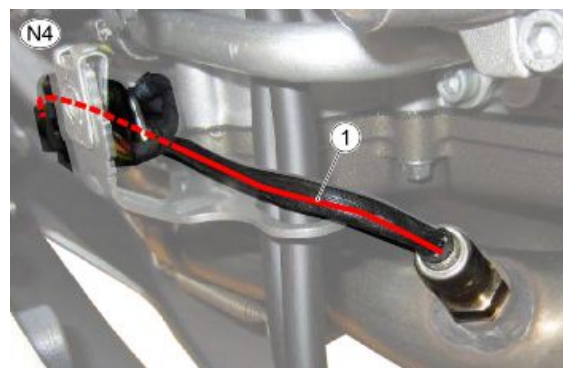

**WIRING TABLE O - AIR FILTER HOUSING
ZONE**

Position the side stand switch, Quick Shift and gear sensor connectors under the two corrugated tubes

**WIRING TABLE O1 - AIR FILTER HOUSING
ZONE**

Check that the clamp fastens all the cables, especially the Quick Shift cable. The cable must be secured so that it cannot slip down and come into contact with the exhaust system.

1. Quick Shift wiring harness
2. Clamp

**WIRING TABLE O2 - AIR FILTER HOUSING
ZONE**

Check that the gear sensor connector has been connected correctly.



WIRING TABLE O - AIR FILTER HOUSING ZONE

Check that the quick shift sensor connector is connected correctly

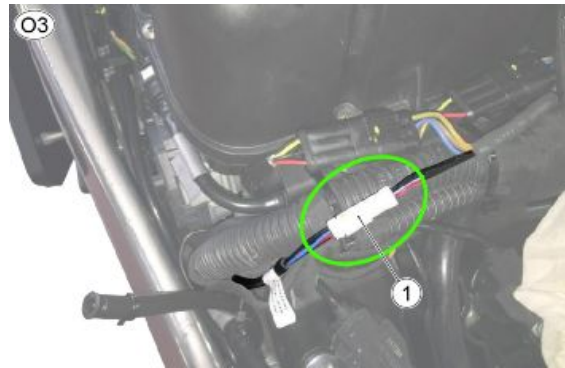

WIRING TABLE O - AIR FILTER HOUSING ZONE

Check that the side stand switch connector is connected correctly.

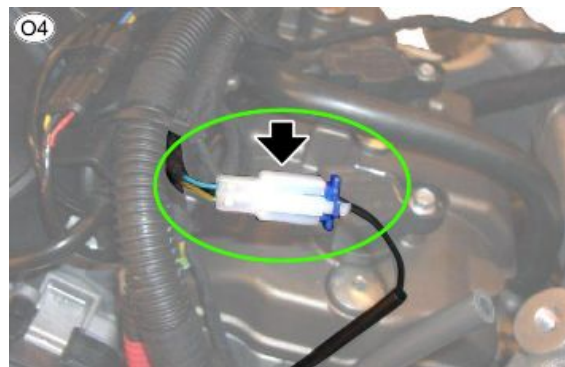

Back side

TABLE A - LICENSE PLATE FRAME PRE-FITTING

The right arrow is identified with the RED taping and must be inserted on the license plate holder as indicated in the picture. The arrow with the red tape must be connected with the wiring harness branch that includes the grey tape

1. Left LED indicator
2. Right LED indicator
3. Grey tape
4. Red tape

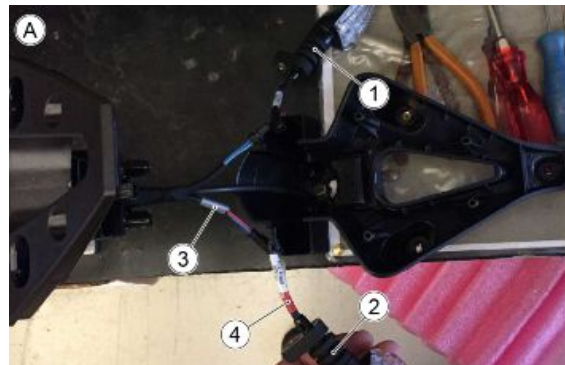

TABLE A1 - LICENSE PLATE HOLDER PRE-FITTING

Bring all cables, including connectors in the hole of the plate holder as in the picture and close all paying attention not to pinch the cables

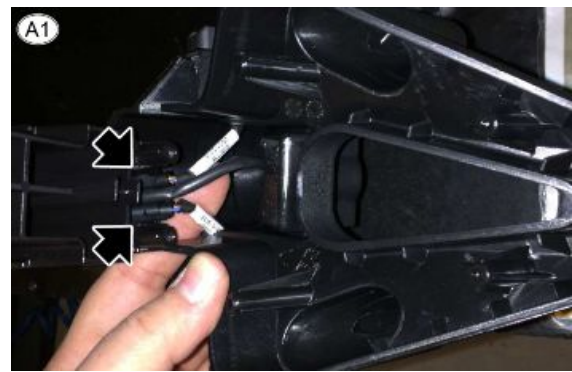

TABLE B - REAR ABS SPEED SENSOR PRE-FITTING

1. ABS speed sensor



TABLE B1 - REAR ABS SPEED SENSOR PRE-FITTING

1. ABS speed sensor wiring harness
2. Cable grommets

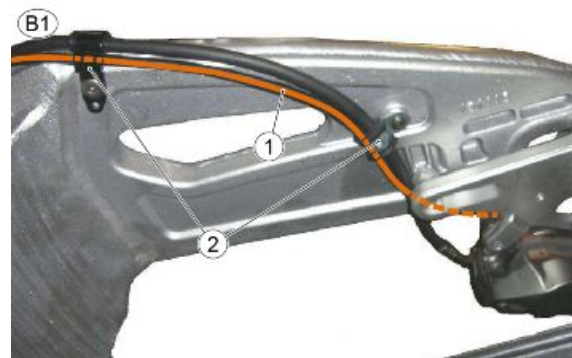

TABLE C - PROCEDURE FOR CORRECT ABS CONTROL UNIT CONNECTOR INSERTION

The initial position of the connector fastener lever must be as shown in the figure

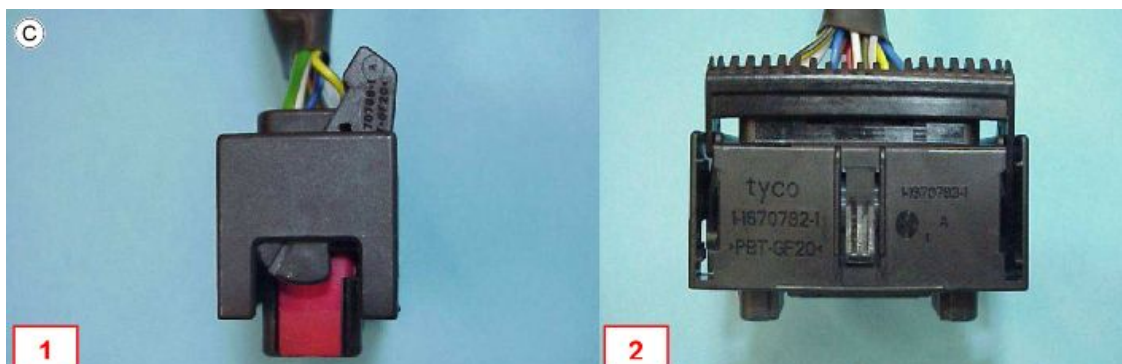

TABLE C1 - PROCEDURE FOR CORRECT ABS CONTROL UNIT CONNECTOR INSERTION

Place the connector on the opposite side of the control unit and lower the driving lever until the "click" that signals the end of the stroke is heard

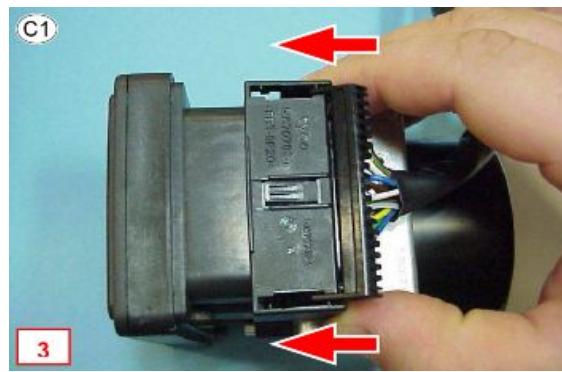

TABLE C2 - PROCEDURE FOR CORRECT ABS CONTROL UNIT CONNECTOR INSERTION

When the connector is fully inserted, the measured distance between the connector and the ABS control unit must be 7.5 mm



TABLE C3 - PROCEDURE FOR CORRECT ABS CONTROL UNIT CONNECTOR INSERTION

If the initial position of the connector and the pulling level is not as the one shown in "TABLE C", the connector will not hook correctly and the measured distance will be higher (around 12 mm). In this case repeat the operation as described in "TABLE C1/C2"

It is advisable to create a jig in order to check the correct connector insertion.

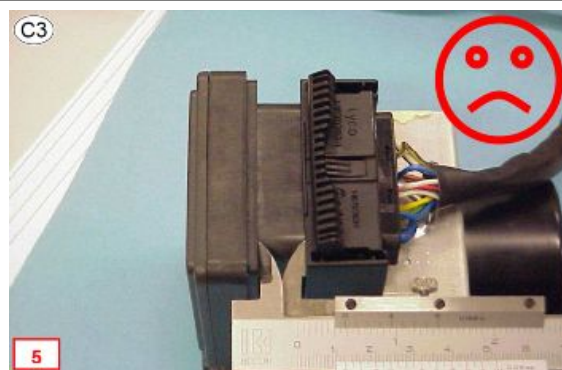

WIRING TABLE D - ABS ON SADDLE MOUNTING

Check that the connector has been inserted correctly, as described in the preceding TABLES

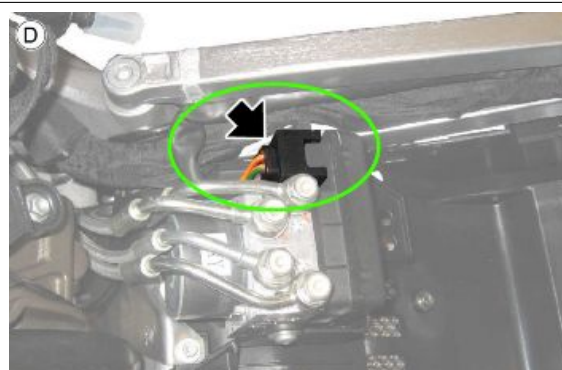

WIRING TABLE D1 - ABS ON SADDLE MOUNTING

The reference taping is purely indicative, position the clamp so that it is aligned with the hole on the saddle mounting. (the clamp may not be positioned above the taping)

Position the clamp without tightening it but allowing it rotate of its own accord.

Insert the tip of the clamp into the hole on the saddle mounting and push it until it locks into place.

1. Grey taping
2. Clamp
3. Saddle mounting hole

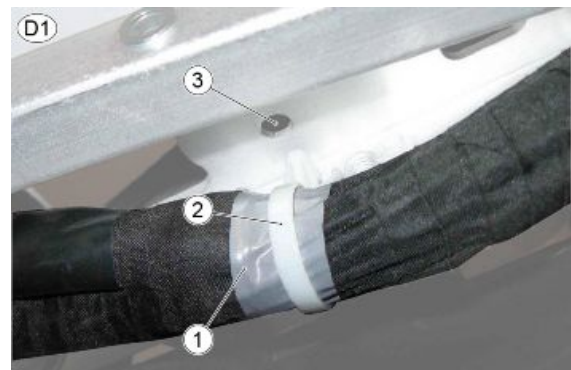
**WIRING TABLE D2 - ABS ON SADDLE MOUNTING**

IF THIS WIRING ABS FUSES-BATTERY) IS NOT SECURED CORRECTLY IT MAY CAUSE THE VEHICLE TO CATCH FIRE

Check that the connected is securely attached and that all the terminals are in place. Position it as indicated

1. ABS speed sensor connector
2. ABS positive wiring
3. ABS fuses

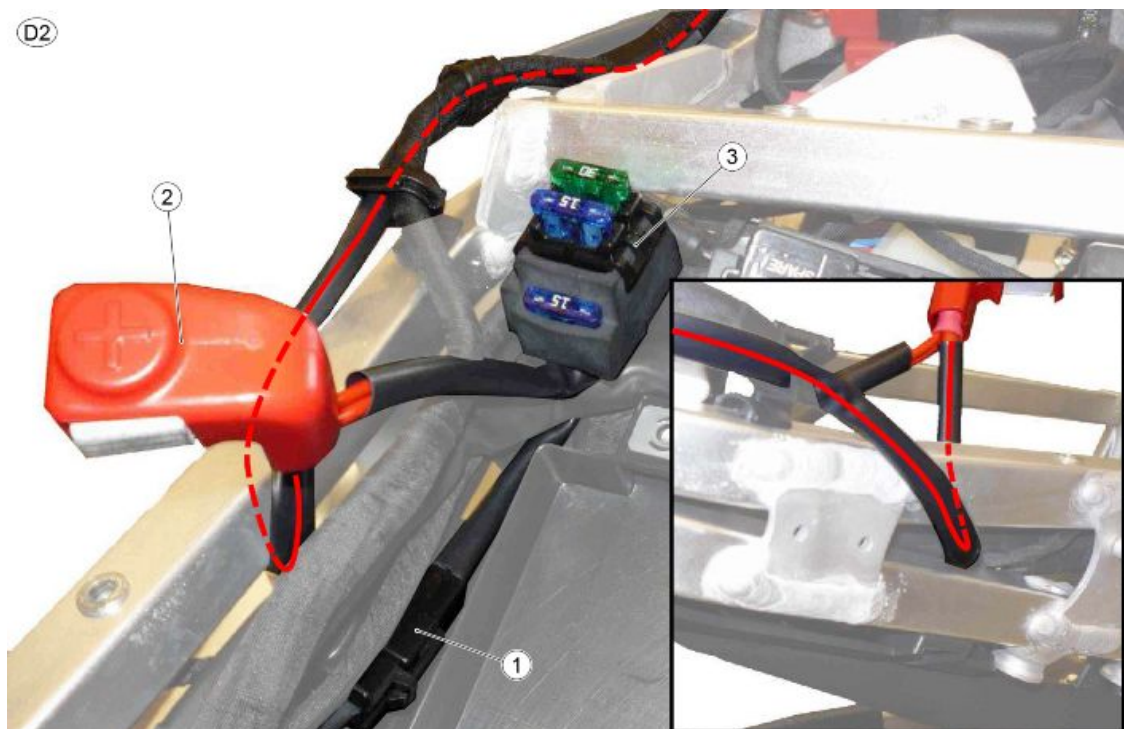

WIRING TABLE E - REAR SADDLE MOUNTING ZONE

Preparing the battery support bracket with fuses

- 1. Battery support bracket
- 2. Vehicle wiring harness



TABLE E1 - REAR SEAT POST AREA

Fit the (individual) fan fuse on battery mounting bracket tongue

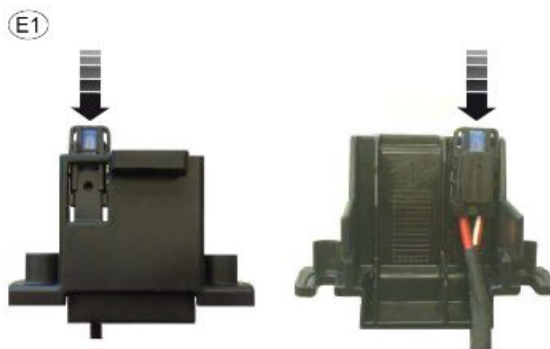

TABLE E2 - REAR SEAT POST AREA

Fuse-box positioning on battery mounting bracket
Insert the fuse-box in the two tongues on the battery mounting bracket

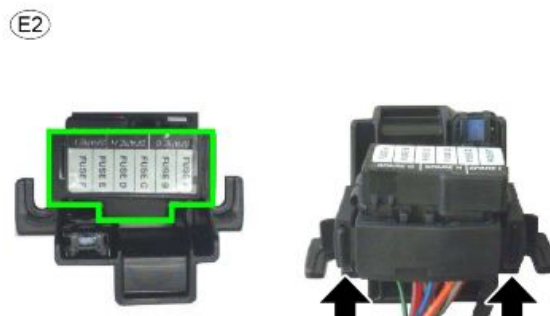

TABLE E3 - REAR SEAT POST AREA

Check that the connector is correctly connected with the protection relay

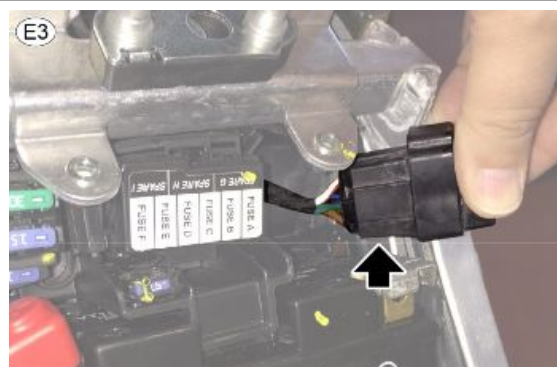
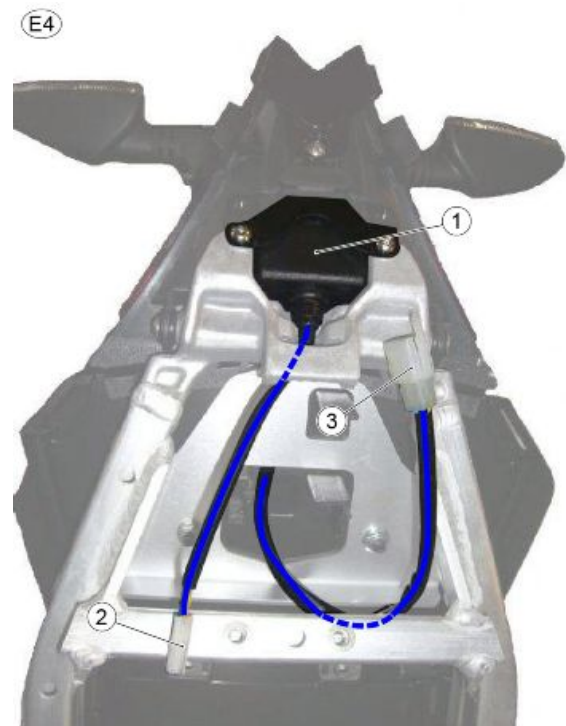

TABLE E4 - REAR SEAT POST AREA

1. Taillight
2. Taillight connector
3. License plate frame wiring harness connector

**WIRING TABLE E5 - REAR SADDLE MOUNTING ZONE**

Insert the ECU diagnostic and the instrument cluster diagnostic connectors in their respective housings

1. ECU diagnostic connector
2. Diagnostic connector
3. Number plate holder wiring connector
4. Taillight connector

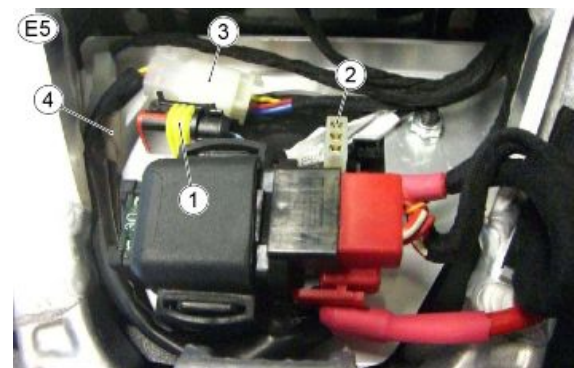
**WIRING TABLE E6 - REAR SADDLE MOUNTING ZONE**

Insert the starter relay between the two plastic flaps

1. Start-up relay
2. Starter motor cable on vehicle wiring harness
3. Starter relay connector
4. Rubber clamp
5. Cable grommet

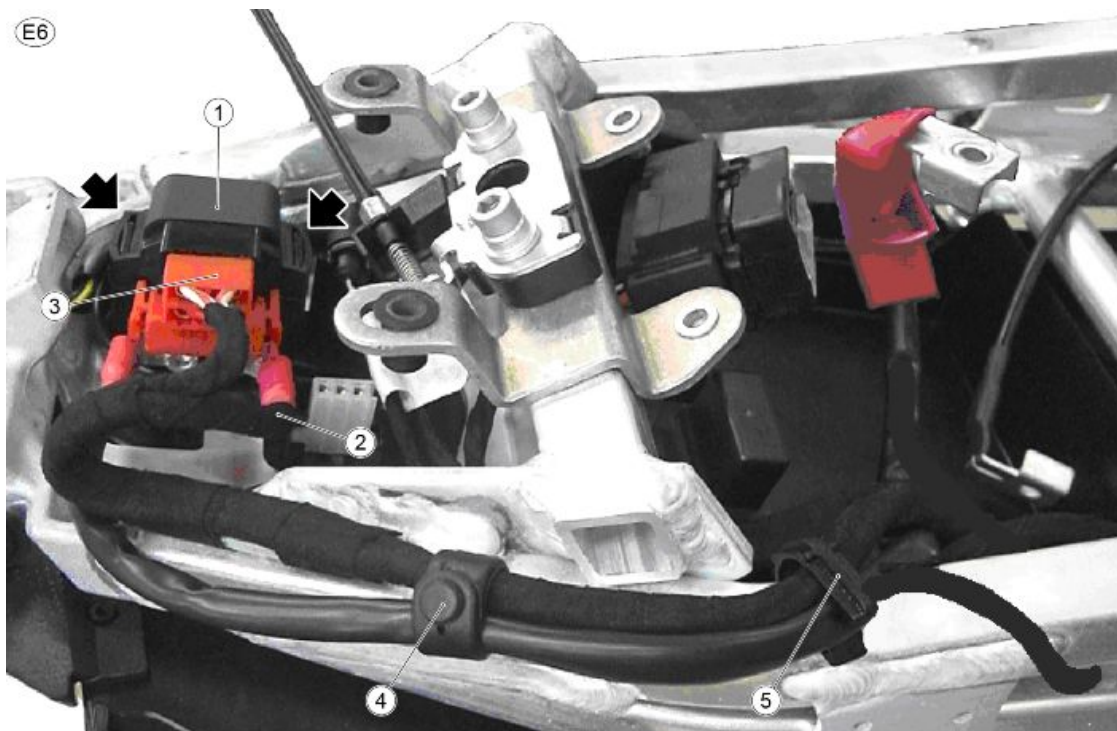

WIRING TABLE F - ENGINE BATTERY EARTH CABLE

- 1. Engine-battery earth cable
- 2. Cable grommet



WIRING TABLE F1 - ENGINE BATTERY EARTH CABLE

- 1. Engine-battery earth cable
- 2. Large clamp
- 3. V4-MP control unit (if fitted)
- 4. Large clamps

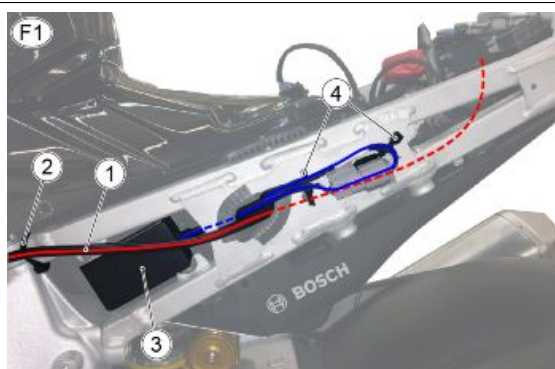

WIRING TABLE G - REAR STOP SWITCH

1. Rear stop switch connector
2. Large clamp

**WIRING TABLE H - SWINGARM ZONE**

1. Rear brake switch wiring
2. Speed sensor wiring
3. Cable fasteners

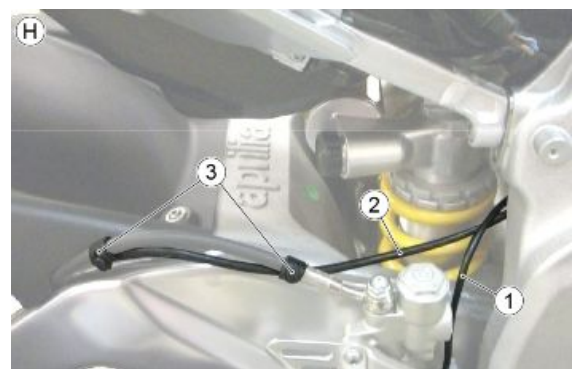
**WIRING TABLE H1 - SWINGARM ZONE**

1. Rear brake switch wiring
2. Speed sensor wiring
3. Cable grommet

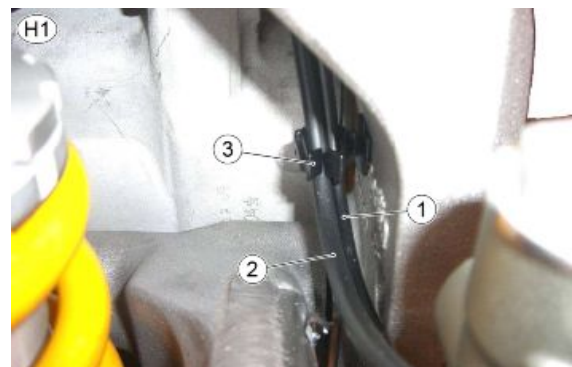
**WIRING TABLE I - REAR ABS SENSOR**

Check that the rear ABS connector is connected correctly and attached to its support.

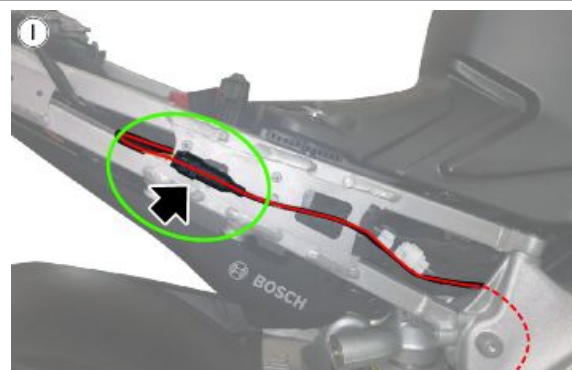

WIRING TABLE I - REAR ABS SENSOR

Route the rear brake switch (2) and rear ABS sensor (3) wiring harness through the cable gland (1)

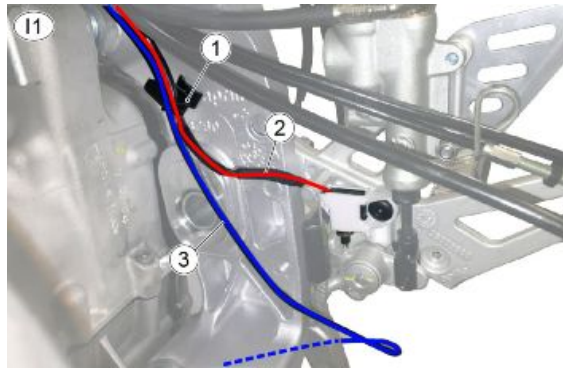

General wiring diagram

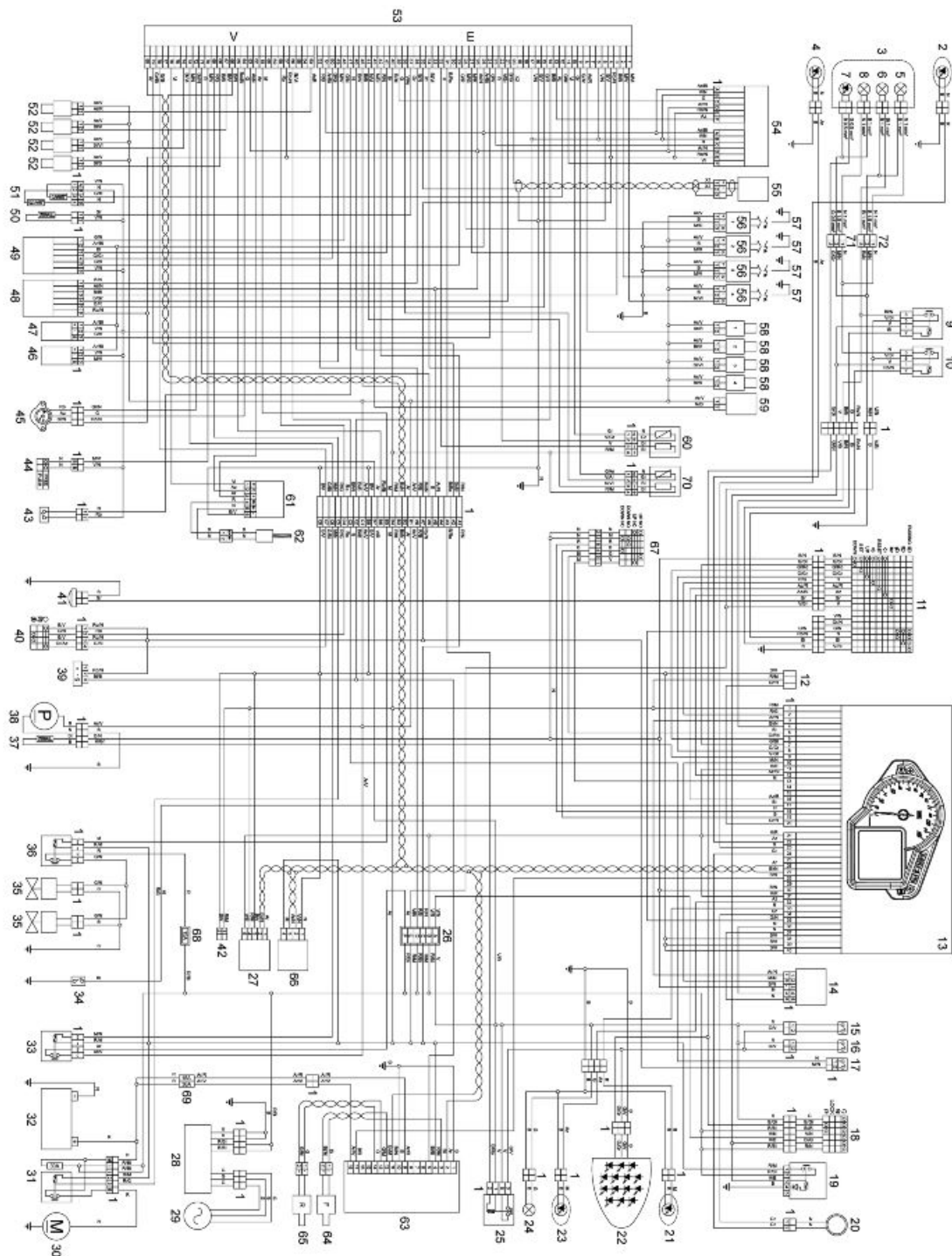

key:

1. Multiple connectors
2. Front right turn indicator (LED)
3. Complete headlamp
4. Front left turn indicator (LED)

5. Right low beam light bulb
6. High beam bulb
7. Tail light bulb (LED)
8. Left low beam light bulb
9. High beam light relay
10. Low beam light relay
11. Left light switch 1
12. Instrument panel diagnosis
13. Instrument panel matrix II
14. Exhaust valve motor
15. Front stop switch
16. Rear stop switch
17. Clutch switch
18. Ignition switch
19. Protection relay
20. Immobilizer antenna
21. Rear right turn indicator (LED)
22. Complete taillight (LED)
23. Rear left turn indicator (LED)
24. License plate light bulb
25. Recovery logic relay
26. Auxiliary fuses
27. BLUEDASH pre-installation
28. Voltage regulator
29. Alternator
30. Starter motor
31. Start-up relay
32. Battery
33. Main injection relay
34. Oil pressure sensor
35. Fan
36. Fan control relay
37. Fuel reserve sensor
38. Fuel pump
39. ECU Diagnosis.
40. Right hand light switch
41. Horn
42. USB pre-installation

- 43. Electronic transmission
- 44. Side stand switch
- 45. Gear sensor
- 46. Front cylinder pressure sensor
- 47. Rear cylinder pressure sensor
- 48. Front cylinder throttles
- 49. Rear cylinder throttles
- 50. Air temperature sensor
- 51. Water temperature sensor
- 52. Upper injectors
- 53. 7SM control unit
- 54. Throttle grip position sensor
- 55. Engine speed sensor
- 56. Coil
- 57. Spark plug
- 58. Lower injectors
- 59. Secondary air system
- 60. Lambda probe 1
- 61. Variable geometry control unit
- 62. Variable geometry engine
- 63. ABS control unit
- 64. Front wheel speed sensor
- 65. Rear wheel speed sensor
- 66. SensorBox
- 67. Left light switch 2
- 68. Fan fuse
- 69. ABS fuses
- 70. Lambda probe 2
- 71. Left headlamp connector
- 72. Right headlamp connector

Checks and inspections

GENERAL NOTIONS FOR TROUBLESHOOTING ELECTRICAL FAULTS

THE SECTIONS RELATIVE TO THE ELECTRICAL SYSTEM CONTAIN DRAWINGS OF CONNECTORS; NOTE THAT THE DRAWING ALWAYS DEPICT THE CONNECTOR/COMPONENT VIEWED FROM THE WIRING HARNESS SIDE, I.E. FROM THE SIDE ON WHICH THE CABLES LEADING FROM THE MAIN WIRING HARNESS ENTER THE CONNECTOR/COMPONENT.

CAUTION

BEFORE STARTING ANY TROUBLESHOOTING PROCEDURES ON THE VEHICLE, CHECK THAT THE BATTERY VOLTAGE IS ABOVE 12V.

CONNECTOR CHECK PROCEDURE

The procedure includes the following checks:

1. Observation and check of the connector correct position on the component or on the coupling connector, making sure that the locking catch is released.
2. Observation of the terminals on the connector: no rust marks or dirt should be present and it is important to check terminal correct positioning on the connector (i.e., all terminals aligned at the same depth) and terminal integrity (i.e., that terminals are not loose, open/bent, etc.). For connectors whose terminals are not visible (e.g. Marelli control unit) use a metal cable of suitable diameter and introduce it carefully in the connector slot at the same depth as for the other terminals of the connector.

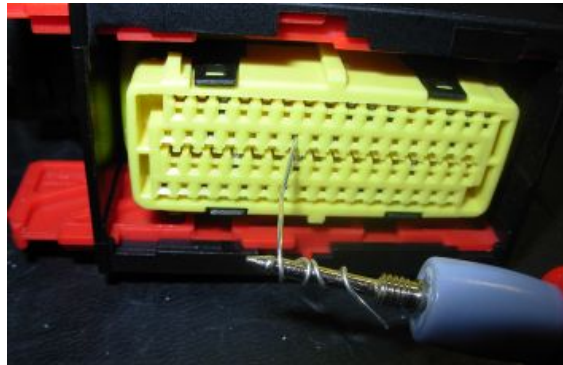

CAUTION

IN THE CASE OF SPORADIC FAULTS, MOVE OR WIGGLE THE RELATIVE WIRING HARNESS SLIGHTLY WHILE PERFORMING EACH OF THE CHECKS INDICATED FOR TROUBLESHOOTING.

3. Pull cables gently from the back of the connector to check that the terminals are fitted correctly on the connector and that the wires are fastened correctly to the terminals.

Checking electrical CONTINUITY

Purpose of check: the purpose of this check is ensure that there are no interruptions or excess resistance (due to corroded terminals, for example) in the circuit under inspection.

Tester: set the tester selector to the "continuity" symbol and place the probes of the tested at the two ends of the circuit. Normally, the tester will sound an audible signal to confirm continuity in the section of circuit tested. Continuity may also be tested by setting the tester selector to the "Ohm" symbol and checking that the resistance in the circuit is zero or of a few tenths of an Ohm.

IMPORTANT: THE CIRCUIT MUST BE UNPOWERED DURING THIS TEST. IF THE CIRCUIT IS POWERED, THE RESULTS OF THIS TEST ARE MEANINGLESS.

Checking GROUND CONNECTION

Purpose of check: the purpose of this check is to verify that a cable or circuit is correctly connected to the ground (-) of the vehicle.

Tester: set the tester selector to the "continuity" symbol and place one of the tester probes on the vehicle ground point (or on the battery negative pole) and the other probe on the cable under inspection. Nor-

mally, the tester will sound an audible signal to confirm continuity in the section of circuit tested. Continuity may also be tested by setting the tester selector to the "Ohm" symbol and checking that the resistance in the circuit is zero or of a few tenths of an Ohm.

IMPORTANT: WHERE GROUND IS PROVIDED BY THE ECU, CHECK THAT THE ECU IS EFFECTIVELY PROVIDING THE GROUND CONNECTION FOR THE CIRCUIT DURING THE TEST.

Checking VOLTAGE

Purpose of check: the purpose of this check is to determine if a cable is carrying voltage, in other terms, to verify whether it powered by the battery or ECU.

Tester: set the tester selector to the "DC voltage" symbol and place the red tester probe on the cable under inspection and the black tester probe on the vehicle ground point (or on the battery negative pole).

CAUTION

IN THE CASE OF SPORADIC FAULTS, MOVE OR WIGGLE THE RELATIVE WIRING HARNESS SLIGHTLY WHILE PERFORMING EACH OF THE CHECKS INDICATED FOR TROUBLESHOOTING.

Immobiliser

System components

Function

detects the transponder code in the key and sends it to the instrument panel

Level in electrical circuit diagram:

Immobilizer

Position:

- on the vehicle: in the ignition switch assembly
- connector: two-way, black, inside the bow

Electrical specifications

- 14 Ohm

Pin out

not significant

CAUTION

BEFORE CARRYING OUT ANY TROUBLESHOOTING, CAREFULLY READ THE GENERAL TROUBLESHOOTING CONCEPTS FOR ELECTRICAL DEVICES AT THE BEGINNING OF THE CHECK AND CONTROL SECTION IN THE ELECTRICAL SYSTEM CHAPTER.

INSTRUMENT PANEL: ERRORS

B0003 Immobilizer fault

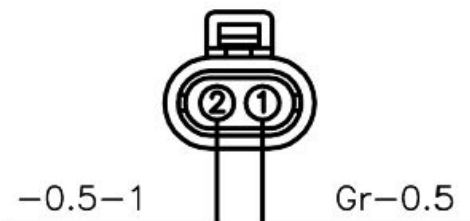

- key code read but not recognised

Error cause

- The read code is not stored in the instrument panel memory

Troubleshooting

- Carry out key data storage procedure

B0004 Immobilizer fault

- read key code not read (key not present or transponder not working)

Error cause

- Key transponder does not communicate its own code

Troubleshooting

- Replace the key

B0005 Immobilizer fault

- Immobilizer fault: aerial not working (open or short-circuited)

Error cause

- An electric interruption or a ground short circuit or voltage to the circuit have been detected

Troubleshooting

- Check the sensor connector on the cable harness and the instrument panel connector. If not OK, restore; if OK, check electrical characteristics and aerial circuit continuity from the instrument panel connector on PIN 2 and 3: if not OK, restore cable harness; if OK, check circuit ground insulation: if not ground insulated, restore cable harness; if insulated, with key ON, with instrument panel connector disconnected, check that there is not voltage at the circuit ends: if there is voltage, restore the cable harness

B0006 Internal controller fault

Error cause

- There is a fault in the instrument panel

Troubleshooting

- Replace the instrument panel
-

System not programmed

Storing new keys

NOTE

REGARDLESS OF THE LANGUAGE SET IN THE DASHBOARD FUNCTIONS, THE KEY PROGRAMMING PROCEDURE CAN ONLY BE VIEWED IN ENGLISH.

- To carry out the one or more key programming procedures, up to a maximum of four, you must connect the motorcycle to the diagnostic tool.
- Turn key to "ON" and insert the USER CODE where required.
- Carry out the self-diagnosis of the dashboard and enter the "SETTINGS" section by clicking on "RESET KEYS".
- At this point, a screen with a warning message will be visible. Press "OK" and start programming the keys.

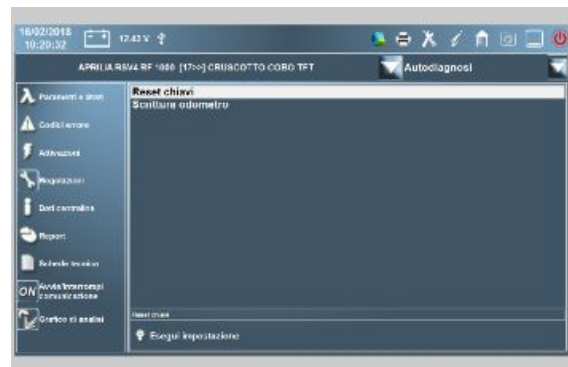
**NOTE**

IF THE IMMOBILIZER ANTENNA IS DISCONNECTED, YOU WILL NOT BE ABLE TO START KEY PROGRAMMING.

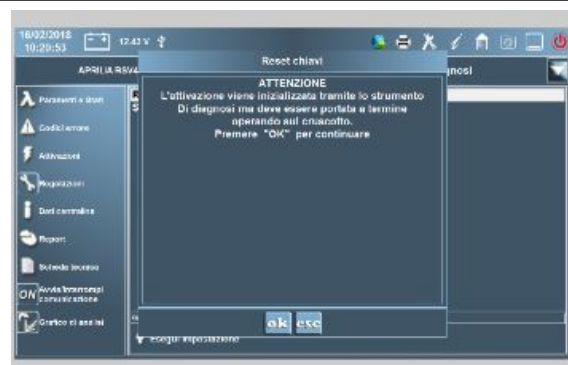

- Enter the USER CODE to continue.
- If the code entered is correct, the first key is stored.

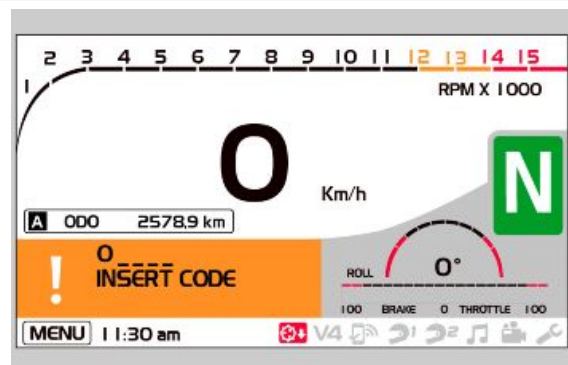

- At this point, on the digital display of the motorcycle, after the automatic restart of the dynamic presentation screen, a message will appear with a countdown of 20 seconds to insert the second key to be programmed.
- Set key to "OFF", insert the second key and set to "ON".

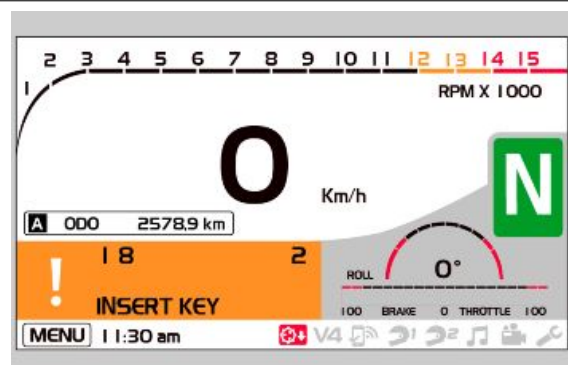
**CAUTION**

IF YOU DO NOT HAVE A SECOND KEY OR YOU DON'T WANT TO STORE ONE, THE DIAGNOSTIC TOOL WILL SHOW AN ERROR SAYING "1 KEY STORED"

- The second key is stored and you will be asked to enter the third key (if you have one). The same operation will be repeated to store the fourth key.
- To complete AND end the memorisation procedure, set key to "OFF".
- You should then test the correct functioning of all keys stored.

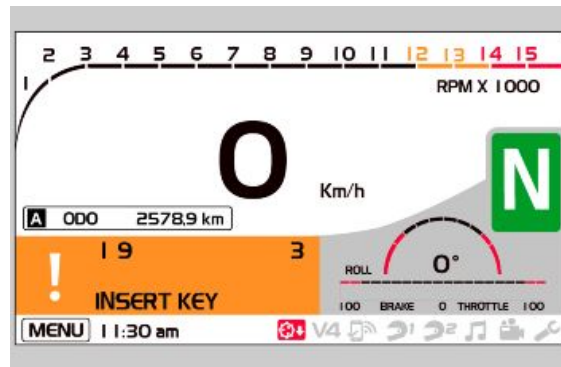

Dashboard

In case of doubts in operation of the engine revs indication, it is possible to connect the vehicle to the diagnostics instrument and activate the engine revs indication choosing the function "Rpm indicator" from the "Devices Activation" screen page (injector icon)

Diagnosis

- In case of malfunction of certain organs, the digital display of the instrument panel may display errors. To check and diagnose the specific component, check the dedicated section.

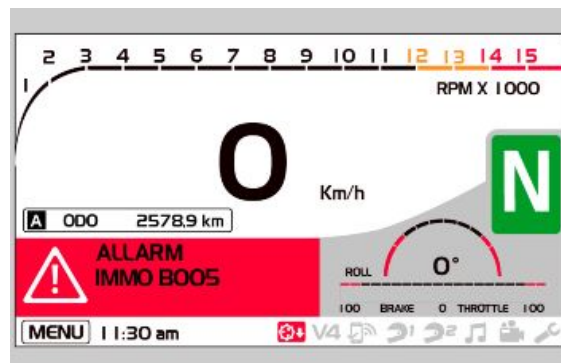

Azzeramento icona manutenzione

The system displays the function as follows:

- After the maintenance interval thresholds are exceeded (excepting the first), an icon with the adjustable wrench is shown on the digital display.

To reset Service proceed as follows:

- Connect the diagnostic tool;
- Select the concerned model;
- Enter in the "INSTRUMENT PANEL" section;

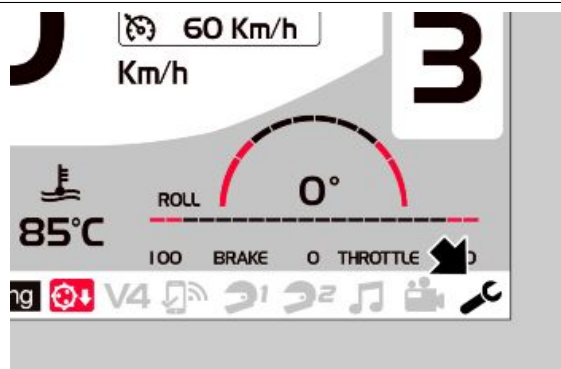

- Select "SELF-DIAGNOSIS";
- Select "ACTIVATIONS";
- Enable the command "SERVICE RE-SET".

Battery recharge circuit

RECHARGING SYSTEM

- Remove the left side fairing;
- Disconnect the three-way connector (1) (white).

NOTE

THE ENGINE SIDE IS IDENTIFIED WITH THE LETTER "A"

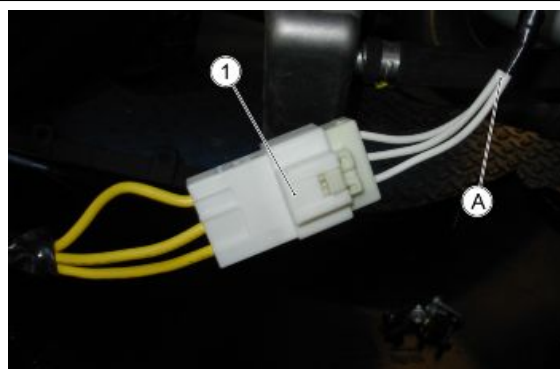

Measurement of resistance (with engine off)

- For a correct detection of the alternator resistance, an ambient temperature measurement must be carried out and afterwards a heat stabilisation (after turning fan on) by using a tester, using alternatively the 3 connector pins: stage "1" (pin 1-2), stage "2" (pin 1-3), stage "3" (pin 2-3).

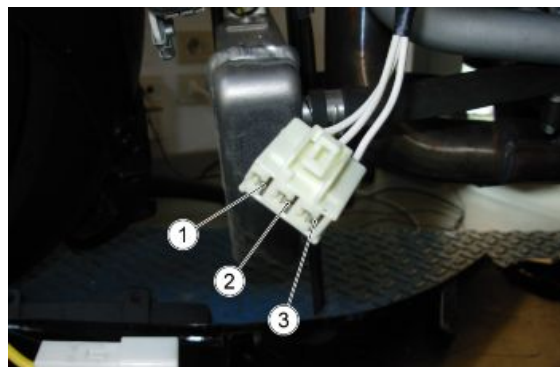

- Take the measurement; The correct value is determined by the value measured for each stage in which from time to time the resistance of the tester wires is subtracted, obtained by touching the two lugs.

Example:

- Resistance of stage 1 read on the display = 0.62 Ohm



- Resistance of the wires read on the display = 0.47 Ohm

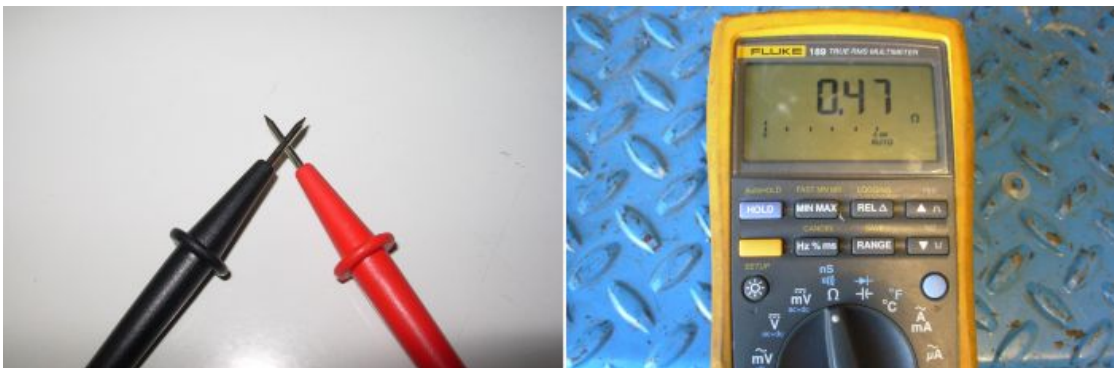

- Effective resistance stage 1 = $0.62 - 0.47 = 0.15$ Ohm
- If there is a significant difference between one stage and another (other than 0.15 Ohm), this means that the alternator is defective and must be replaced.

RESISTANCE MEASURE

Winding stage	Ambient temperature (ohm)	Afterwards heat stabilisation (ohm)
Stage 1	0.15 - 0.20	0.25 - 0.30
Stage 2	0.15 - 0.20	0.25 - 0.30
Stage 3	0.15 - 0.20	0.25 - 0.30

Zero load voltage

- Disconnect the three-way connector (1);
- For a correct detection of the alternator voltage, a measurement must be carried out using alternatively the 3 engine side connector pins: stage "1" (pin 1-2), stage "2" (pin 1-3), stage "3" (pin 2-3)
- Take the measurements;
- If there is a significant difference between one stage and another (other than 15 V), this means that the alternator is defective and must be replaced.

CAUTION

WITH THE ENGINE HOT THE VALUES RECORDED ARE ON AVERAGE 4-5 V LESS THAN THOSE DETECTED WITH THE ENGINE COLD.

ZERO LOAD VOLTAGE

rpm	2000	4000	6000	8000
Vm line-to-line voltage Reference values (V rms)	22 - 27	46 - 51	69 - 74	92 - 97

Short-circuit current

- For a correct detection of the short-circuit current, a connector must be prepared that generates a downstream short circuit between the three alternator cables;
- Start the engine and with an ammeter clamp measure each single cable.
- If there is a significant difference between the measure of the single cables (other than 10 A), this means that the alternator is defective and must be replaced.



CAUTION

WITH THE ENGINE HOT THE VALUES RECORDED ARE ON AVERAGE 2-3 A LESS THAN THOSE DETECTED WITH THE ENGINE COLD.

WARNING

NEVER KEEP THE ENGINE RUNNING FOR MORE THAN ONE MINUTE; FAILURE TO DO SO COULD CAUSE SERIOUS OVERHEATING DAMAGES TO THE MOTORCYCLE CIRCUITS.

COLD SHORT-CIRCUIT CURRENT

RPM	2000	4000	6000	8000
RMS DC current (Arms) (average of the 3 stage currents)	22 - 27	22 - 27	22 - 27	22 - 27

Voltage on battery poles with engine speed always between 3000 - 5000 RPM

- Start the engine, after about one minute of operating bring the speed to 3000-5000 RPM, then measure with a tester the voltage at the battery poles that must always be between 13V and 15V. Otherwise, if the correct operation of the alternator has already been checked, replace the regulator.

CAUTION

PERFORM THE CHECK DESCRIBED ABOVE WITH A BATTERY IN GOOD CONDITION (START VOLTAGE ABOUT 13V) MAKING SURE THAT THERE ARE NO ELEMENTS IN THE SHORT CIRCUIT.

Start-up system check

Function

Communicates to the control unit the will to start-up the engine.

Operation / Operating principle

Press the start-up button to close the specific circuit taking the PIN 58 of the control unit to a voltage equal to zero (ground closing).

Level in electrical circuit diagram:

Start enable switches

Position:

- on the vehicle: Right hand light switch.
- connector: inside the support (4-ways black).

Electrical specifications:

- key released: open circuit
- key pressed: closed circuit

Pin out:

2: voltage + 5V

3: ground

CAUTION

BEFORE CARRYING OUT ANY TROUBLESHOOTING, CAREFULLY READ THE GENERAL TROUBLESHOOTING CONCEPTS FOR ELECTRICAL DEVICES AT THE BEGINNING OF THE CHECK AND CONTROL SECTION IN THE ELECTRICAL SYSTEM CHAPTER.

DIAGNOSTIC TOOL: ELECTRICAL ERRORS

P0615 Starter relay

- short circuit to positive / open circuit, short circuit to negative.

Error cause

- Short-circuit to positive: excessive voltage identified at PIN 69, at the command time; If open circuit, short circuit to negative: a voltage close to zero was identified when there is no command to the start-up relay.

DIAGNOSTIC TOOL: LOGIC ERRORS

P0512 Starter switch

- signal not plausible.

Error cause

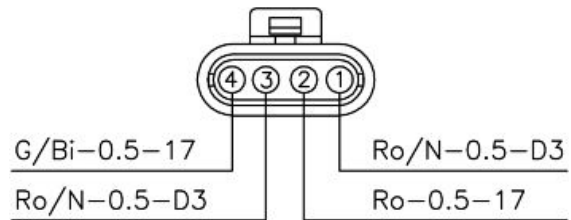

- Fault in the switch (lock) of the engine start-up. A continuous voltage close to 0 was detected for a certain time (e.g. locked button).
- The instrument panel does not indicate the presence of this error even in the ATT status.

Troubleshooting

- Check the locking cause and restore.

Fuses

AUXILIARY FUSES DISTRIBUTION

Specification	Desc./Quantity
A) 5A fuse	Stop and running lights relay
B) 10A fuse	Instrument panel, turn indicators, instrument panel diagnostics, exhaust valve
C) 15A fuse	ECU
D) 7.5A fuse	ECU (2)
E) 15A fuse	High beam/low beam, horn.
F) 15A fuse	Coils, injectors, fuel pump, secondary air, injection relay

Auxiliary fuses are placed in the central part of the motorcycle, under the rider saddle.

ABS FUSE LAYOUT

Specification	Desc./Quantity
M) fuse of 15A	ABS solenoid valves.
N) fuse of 30A	ABS pump motor.

WHERE CONTEMPLATED

CAUTION

THREE OF THE FUSES ARE SPARES (H).

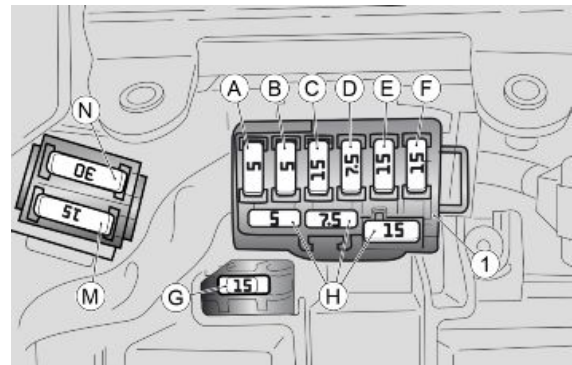

MAIN FUSES DISTRIBUTION

Specification	Desc./Quantity
H) 15A fuse	Fans
I) 30A fuse	Battery recharge, positive switched live, permanent positive under instrument panel, sensor box positive switched live, fan relay

Main fuses are placed in the rear part of the motorcycle, under the passenger seat.

CAUTION

THERE IS ONE SPARE FUSE (I).

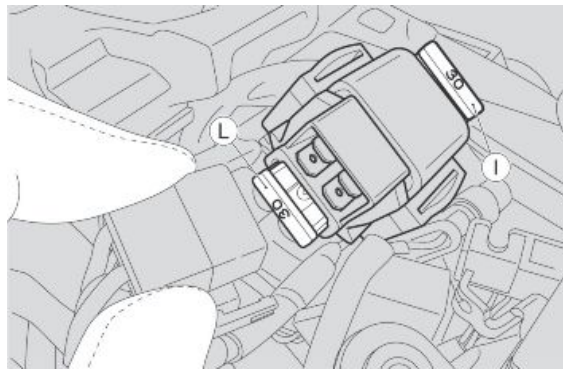
**Control unit****Removal**

- Remove the fuel tank.
- Disconnect both control unit connectors



- Unscrew and remove the three screws.
- Remove the control unit.

**NOTE**

WHEN REASSEMBLING THE CONNECTORS, THE SLIDES MUST SLIDE FREELY UP TO THE LIMIT STOP, THUS FACILITATING THE CONNECTOR'S INSERTION. THE CATCH SHOULD SNAP INTO PLACE ONCE THE LIMIT STOP IS REACHED.

CONTROL UNIT - Diagnosis**Function**

It manages the Ride by wire system, the injection/ignition, the system safety checks and the self-diagnosis function

Level in electrical circuit diagram:

Each level in which the main component involves the control unit

Position:

- on the vehicle: above the filter box
- connector: on connector control unit of ENGINE PIN 52 (figure A), connector of VEHICLE PIN 28 (figure B)

Pin out: See CONNECTORS paragraph

DIAGNOSTIC TOOL:INFO

(screen page/example values with key ON)

- Drawing number / - (identified inserted by the manufacturer)
- HW number / - (indicates the Hardware number)
- Hardware version / -
- Mapping / - (indicates the mapping number)
- Software version / -
- Type approval number / -
- ISO code / -
- Marelli SW code / -
- Serial number (NIP)
- Author of the latest progr. / - (author of the latest programming)
- Internal code (IDEEKE) / -
- Internal code (IDVAG1) / -
- Hardware code / - (indicates the hardware code)
- VIN / - (vehicle identification number)

DIAGNOSTIC TOOL:PARAMETERS AND STATUSES**PARAMETERS:**

- Engine rpm / -
- Air temperature / -
- Engine temperature / -
- Engine temp. at start-up / - (the temperature of the engine at start-up)



-
- Track A position sensor / - (track A handle position sensor)
 - Track B position sensor / - (track B handle position sensor)
 - % of handle openings / - (percentage of handle openings)
 - Rear thr.val. pot.1 (volt) / - (rear throttle valves potentiometer 1 (voltage))
 - Rear thr.val. pot.2 (volt) / - (rear throttle valves potentiometer 2 (voltage))
 - Front thr.val. pot.1 (volt) / - (front throttle valves potentiometer 1 (voltage))
 - Front thr.val. pot.2 (volt) / - (front throttle valves potentiometer 2 (voltage))
 - Rear thr.val. pot.1 (degrees) / - (rear throttle valves potentiometer 1 (degrees))
 - Front thr.val. pot.1 (degrees) / - (rear throttle valves potentiometer 1 (degrees))
 - Rear int. pres. (1 and 3) / - (rear cylinders intake pressure (1 and 3))
 - Front int. pres. (2 and 4) / - (front cylinders intake pressure (2 and 4))
 - Rear est. int. pres. (1 and 3) / - (rear cylinders estimated intake pressure (1 and 3))
 - Front est. int. pres. (2 and 4) / - Front cylinders estimated intake pressure (2 and 4)
 - Actuated advance / - real cylinder advance
 - Battery voltage / -
 - Rear lambda 1 voltage / - (indicates the rear bank lambda probe 1 voltage)
 - Front lambda 2 voltage / - (indicates the front bank lambda probe 2 voltage)
 - Rear lambda 1 correction / - (rear bank lambda 1 correction)
 - Front lambda 2 correction / - (front bank lambda 2 correction)
 - Rear bank lambda 1 / - (lambda generated from bank 1 rear bank)
 - Front bank lambda 2 / - (lambda generated from bank 2 front bank)
 - Air flow rate / - (indicates the intake air quantity for each engine cycle)
 - Cylinders efficiency / - (of the cylinders injection)
 - Rear cul. throt. val. corr. / - (rear cylinders throttle vale correction)
 - Front cul. throt. val. corr. / - (front cylinders throttle vale correction)
 - Fuel flow rate / -
 - Rear lambda 1 adap. correction / - (rear lambda 1 adaptive correction)
 - Rear thr. val. Limp Home / - (rear cylinders throttle valves limp home position)
 - Front thr. val. Limp Home / - (front cylinders throttle valves limp home position)
 - Rear thr. val. low. pos / - (rear throttle valves lower position)
 - Front thr. val. low. pos / - (front throttle valves lower position)
 - Vehicle speed / -
 - Exhaust val. obj. pos / - (exhaust valve objective position)
 - Front wheel speed / -
 - Rear wheel circumf. / - (rear wheel circumference)
 - Final transm. ratio / - (final transmission ratio)
 - track equiv. km (partial) / - (track equivalent km counter resettable from the instrument)
 - track equiv. km (total) / - (track equivalent km total counter)

- Ign. sw. ass. err. count / - (ignition switch assembly errors count)
- Equiv. km rest counter / - (counter of the resets perform on the partial equivalent km)
- Gear sensor voltage/ -
- Front lambda 2 adap. corr. / - (front lambda 2 adaptive correction)

STATUSES:

- Rear lambda 1 control / - (rear bank lambda 1 control)
- Front lambda 2 control / - (front bank lambda 2 control)
- Rear thr. val. auto self-learn. / - (rear throttle valve automatic self-learning)
- Front thr. val. auto self-learn. / - (front throttle valve automatic self-learning)
- Engine status / -
- Engine mode / -
- Han / -
- Gearbox in neutral / -
- Gear engaged / - (indicates the gear engaged)
- Fan relay / -
- Permission from the immobilizer / -
- Tone wheel synch / - (tone wheel synchronization status)
- Side stand
- Fall sensor / -
- RUN/STOP switch / -
- Clutch / -
- Clutch signal / -
- Start-up enabl / - (start-up enabling)
- Rear lambda 1 probe / - (rear bank lambda 1 probe)
- Front lambda 2 probe / - (front bank lambda 2 probe)
- Handle self-cleaning / - (handle self-learning)
- Thr. self-learn. diag. instrum. / - (throttle self-learning with diagnostics instrument)
- Exhaust valve / -
- Button + / -
- Button - / -
- Quick shift lever / - (Quick shift lever enabling)
- Cruise control / - (indicates the cruise control status)
- Front brake qual. switch / - (front brake lever qualified switch)
- Rear brake qual. switch / - (rear brake lever qualified switch)
- Front brake "raw" switch / - (front brake lever "raw" switch)
- Rear brake "raw" switch / - (rear brake lever "raw" switch)
- Front brake lever switch / - (front brake lever switch)

- Rear brake lever switch / - (rear brake lever switch)
- ON-OFF cruise button/ - (indicates the status of the button concerning the cruise control on the steering wheel)
- Cruise control SET + / -
- Cruise control SET - / -

DIAGNOSTIC TOOL:ACTIVATIONS

- Rear coil 1 / - (rear bank coil 1)
- Front coil 2 / - (front bank coil 2)
- Rear coil 3 / - (rear bank coil 3)
- Front coil 4 / - (front bank coil)
- Fuel pump / -
- Tachometer / -
- Rear lambda 1 heater / - (rear bank lambda 1 probe heater)
- Rear cul. 1 low. inject. / - (rear bank cylinder 1 lower injector)
- Front cul. 2 low. inject. / - (front bank cylinder 2 lower injector)
- Rear cul. 3 low. inject. / - (rear bank cylinder 3 lower injector)
- Front cul. 4 low. inject. / - (front bank cylinder 4 lower injector)
- Rear cul. 1 upp. inject. / - (rear bank cylinder 1 upper injector)
- Front cul. 2 upp. inject. / - (front bank cylinder 2 upper injector)
- Rear cul. 3 upp. inject. / - (rear bank cylinder 3 upper injector)
- Front cul. 4 upp. inject. / - (front bank cylinder 4 upper injector)
- Fan
- Front lambda 2 heater / - (front bank lambda 2 probe heater)
- Secondary air valve / - (secondary air solenoid valve activation)
- Stop light

DIAGNOSTIC TOOL: ELECTRICAL ERRORS**P0601 EEPROM error****Electrical diagnosis:**

- Circuit not functioning

Error cause:

- Replace the injection control unit.

The instrument panel indicates this error by lighting up in a fixed manner the MI warning light.

NOTE

THIS ERROR GENERATES THE RECOVERY STATUS AND ENGINE SHUT-DOWN.

P0604 RAM Error**Electrical diagnosis:**

- Circuit not functioning

Error cause:

- Replace the injection control unit.

The instrument panel indicates this error by lighting up in a fixed manner the MI warning light.

NOTE

THIS ERROR GENERATES THE RECOVERY STATUS AND ENGINE SHUT-DOWN.

P0605 ROM Error**Electrical diagnosis:**

- Circuit not functioning

Error cause:

- Replace the injection control unit.

The instrument panel indicates this error by lighting up in a fixed manner the MI warning light.

NOTE

THIS ERROR GENERATES THE RECOVERY STATUS AND ENGINE SHUT-DOWN.

P060B A/D converter**Electrical diagnosis:**

- Circuit not functioning

Error cause:

- Replace the injection control unit.

The instrument panel indicates this error by lighting up in a fixed manner the MI warning light and by flashing the general warning light.

NOTE

THIS ERROR GENERATES THE RECOVERY STATUS AND ENGINE SHUT-DOWN.

P1301 top lights relay error**Electrical diagnosis:**

- short circuit to positive / short circuit to negative / open circuit

Error cause:

- Short-circuit to positive: excessive voltage has been detected on PIN 31.
- If short circuit to negative: no voltage has been detected.
- If open circuit: an interruption has been detected.

The instrument panel indicates this error by lighting up in a fixed manner the general warning light.

Troubleshooting

- Short-circuit to positive: check the correct electrical characteristics of the relay by disconnecting it from the wiring harness, if not ok replace the relay, if ok restore the wiring harness (blue/pink cable)

- If short circuit to negative: check the correct electrical characteristics of the relay by disconnecting it from the wiring harness, if not ok replace the relay, if ok restore the wiring harness (blue/pink cable)
- If open circuit: check the correct electrical characteristics of the relay by disconnecting it from the wiring harness, if not ok replace the relay, if ok perform the check procedure for the relay connector, the engine-vehicle wiring harness connector and the ENGINE connector for the Marelli control unit: if not ok restore, if ok check the continuity of the wiring harness (blue/pink cable)

DIAGNOSTIC TOOL: LOGIC ERRORS

P160C Level 2 safety reset**Error cause:**

- Due to the fact that the level 2 safety system (comparison between requested torque and calculated torque) detected a fault, the control unit reset the engine (severity C).

The instrument panel does not indicate the presence of this error even in the ATT status.

Troubleshooting:

- Perform the troubleshooting for the other detected errors

P060C Safety Engine Stop**Error cause:**

- Due to the fact that the safety system detected a serious fault, the control unit has stopped the engine.

The instrument panel indicates this error by lighting up in a fixed manner the MI warning light and the general warning light.

Troubleshooting:

- Perform the troubleshooting for the other detected errors.

NOTE

THIS ERROR GENERATES THE RECOVERY STATUS AND ENGINE SHUT-DOWN.

P1606 Hardware and software incompatibility**Error cause**

- Incorrect engine control unit mapping

This error is indicated by lighting up in a fixed manner the general warning light.

Troubleshooting

- Call the Help Desk

NOTE

THIS ERROR DETERMINES THE ENGINE STOP AND THE DEACTIVATION OF THE STARTER MOTOR.

P1607 Saved data file (for safety reasons)**Electrical diagnosis:**

- Filled

Error cause

- This indication appears only if the Level 2 safety has reset the engine (C gravity).

The instrument panel does not indicate the presence of this error even in the ATT status

Troubleshooting

- Perform the troubleshooting for the other detected errors.

P1608 a-PRC (Aprilia Performance Ride Control) functional error**Electrical diagnosis:**

- Incorrect a-PRC scheduling / Incorrect CheckSum of the software on Flash / Control unit voltage too low for a-PRC controls

Error cause

- Due to the fact that the safety system detected a serious fault, the control unit has disabled the a-PRC system.

The instrument panel indicates this error by lighting up in a fixed manner the MI warning light.

Troubleshooting

- Contact technical service.

NOTE

THIS ERROR DISABLES THE TRACTION CONTROL.

P1650 Engine events configuration Checksum calculation error**Error cause:**

- Corrupt Flash-EEPROM (hardware problem).
- Upload (e.g. in service) of an incompatible software version, therefore missing the reference check-sum.

This error is indicated by lighting up in a fixed manner the general warning light.

Troubleshooting:

- Call the Help Desk.

DIAGNOSTIC TOOL: ADJUSTMENTS

- Vehicle config. (km) / - (vehicle configuration (km))
- Vehicle config. (miles) / - (vehicle configuration (miles))
- Handle self-learn. / - (handle self-learning)
- Throttle valve self-learn. / - (Throttle valve self-learning)
- EEPROM reset / - (control unit EEPROM memory reset)
- Exhaust valve zero / - (Exhaust valve zero search)
- Exhaust valve self-learn / - (exhaust valve self-learning)
- Equiv. km reset. / - (equivalent km partial counter reset)
- Key err count reset / - (ignition switch assembly errors counter reset)

- Saved data download / - (saved data download)

CAUTION

AFTER CANCELLING ALL THE DATA STORED DURING THE VEHICLE PRODUCTION PHASE (INCLUDING THE SELF-ADAPTIVE PARAMETERS), THE FOLLOWING MUST BE SELECTED: HANDLE SELF-LEARNING AND CHECK THE TWO "AUTOMATIC SELF-LEARNING OF THE FRONT THROTTLE VALVES" AND "AUTOMATIC SELF-LEARNING OF THE REAR THROTTLE VALVES" STATUSES ARE "CARRIED OUT".

Battery**Function**

Provides electrical power to vehicle: the YTZ 10 S MF battery is already activated, charged and sealed; or, alternatively, the YT 12A - BS battery that must be activated and charged.

Level in electrical circuit diagram:

Battery charge

Position:

- on the vehicle: under the saddle
- connector: on the battery

Electrical specifications: 12 V / 18 Ah

Pin out:

1. Positive pole (red): approx. 12,6 V
2. negative pole (black): ground lead

DIAGNOSTIC TOOL:PARAMETERS**Battery voltage**

- Example value with key ON: 12.0 V
- Example value with engine on: 14.2 V

This is one of the values set by the ECU in the event of recovery mode

Battery voltage before prior to Recovery mode

- Example value with key ON: 12.0 V
- Example value with engine on: 14.2 V

Value determined from signal read without taking considering whether recovery mode is implemented

CAUTION

PAY ATTENTION TO THE POSITIVE BATTERY CABLE, WHICH MUST PASS BELOW THE UPPER PART OF THE FRAME.

CAUTION

BEFORE CARRYING OUT ANY TROUBLESHOOTING, CAREFULLY READ THE GENERAL TROUBLESHOOTING CONCEPTS FOR ELECTRICAL DEVICES AT THE BEGINNING OF THE CHECK AND CONTROL SECTION IN THE ELECTRICAL SYSTEM CHAPTER.

DIAGNOSTIC TOOL: LOGIC ERRORS

P0560 Battery voltage

- too high/too low

Error cause

- If too high: too high a voltage has been detected at PIN 42. If too low: too low a voltage has been detected at PIN 42.

The instrument panel indicates this error by lighting up in a fixed manner the MI warning light.

Troubleshooting

- If too high: check that the voltage regulator is working correctly.
- If too low: check voltage regulator connectors, engine-vehicle wiring harness connector and ECU connector (check in particular for oxidation): if not OK, restore; if OK, check that the Red/White cable resistance between the voltage regulator connector and the control unit connector is a few tenths of Ohm: if not OK, repair the wiring harness; if OK, check that the electric generator is operating correctly: if not OK, repair. If OK, check that the voltage regulator is working correctly

P1560 Low battery voltage error - GCC error

Functional diagnosis:

- low voltage

Error cause

- The error is activated if, after 5 seconds from the key ON, the battery voltage is deemed low by the control unit.
- Low a voltage has been detected at PIN 52 of the Marelli control unit.

This error is indicated by lighting up in a fixed manner the general warning light.

Troubleshooting

- Try to recharge/replace the battery: if NOT OK, perform the check procedure for the alternator connector and the control unit connector (paying special attention to any signs of oxidation): if NOT OK, restore; if OK, check that cable resistance between the alternator cable and the control unit connector is a few tenths of Ohm: if not OK, repair the wiring harness; if OK, check that the electric generator is operating correctly: if not OK, repair.

NOTE

THIS ERROR DISABLES THE TRACTION CONTROL AND THE CRUISE CONTROL.

Speed sensor

FRONT VEHICLE ABS SENSOR

Function:

Generates a signal used by the ABS control unit to determine the speed value of the wheel.

Operation / Operating principle:

Magneto-resistive sensor: generates a square wave signal with an amplitude of approximately 1V between PIN3 and PIN12 of the ABS control unit.

Electrical circuit diagram - Level in electrical circuit diagram:

Traction control - Speed sensor

Position on vehicle:

On left-hand stanchion of fork, near the brake caliper mounting bracket

Position of connector (if applicable):

Under the right dynamic air intake.

Pin-out:

- PIN1 - Power feed negative/Signal negative (white)
- PIN2 - Power feed positive/Signal positive (white/brown)

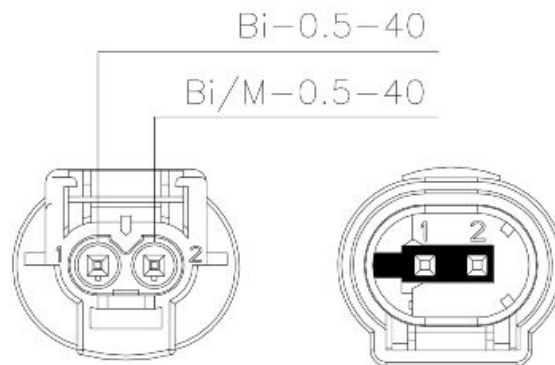

DIAGNOSTIC TOOL

Parameters:

Speed (km/h) - Front wheel speed.

DIAGNOSTIC TOOL: ELECTRICAL ERRORS

C1033 Front wheel speed sensor

Electrical diagnosis:

Open circuit, short circuit to negative or short circuit to positive.

Error cause:

- Open circuit: circuit interruption detected.
- Short-circuit to negative: null voltage detected on PIN 3 of the ABS control unit.
- Short-circuit to positive: excessive voltage detected on PIN 3 of the ABS control unit.

Troubleshooting:

Open circuit:

- Check the connectors on the component and on the ABS control unit.
- Check the integrity and continuity of the wiring harnesses:

- between PIN 3 of the ABS control unit and PIN 1 of the sensor (white cable)
- between PIN 12 of the ABS control unit and PIN 2 of the sensor (white/brown cable)

Short-circuit to negative:

- Disconnect the sensor connector.
- Check the ground insulation of the two PINS.
- If there is no insulation, restore the wiring harness or replace the sensor.

Short-circuit to positive:

- Disconnect the sensor connector.
- Check the battery supply insulation of the two PINS.
- If there is no insulation, restore the wiring harness or replace the sensor.

P0501 Front wheel speed sensor/signal

- Connect to the ABS control unit diagnosis.

DIAGNOSTIC TOOL: LOGIC ERRORS

C1024 Comparison between the front and rear wheel

Electrical diagnosis:

Excessive difference.

Error cause

- Incorrect wheel or tone wheel dimensions.

Troubleshooting

- Check the type and dimensions of the installed tyres.
- Check the type and dimensions of the installed tone wheels.

C1034 Front wheel speed sensor

Functional diagnosis:

Signal not plausible.

Error cause:

- Possible tone wheel fault due to deformations or dirt.

Troubleshooting:

- Check that the tone wheel is not damaged and is clean.
- Check that the number of teeth on the tone wheel is correct
- Check that the tone wheel and the sensor are correctly positioned;
- Check that the tyre is the correct size.
- If all these checks are positive, replace the sensor.

P2162 Wheel speed plausibility

Error cause:

- ABS system malfunction

Troubleshooting:

- Connect to the ABS control unit diagnosis.

REAR VEHICLE SPEED SENSOR

Function:

Generates a signal used by the ABS control unit to determine the speed value of the wheel.

Operation / Operating principle:

Magneto-resistive sensor: generates a square wave signal with an amplitude of approximately 1V between PIN14 and PIN13.

Electrical circuit diagram - Level in electrical circuit diagram:

Traction control - Speed sensor.

Position on vehicle:

Right-hand side of swingarm, on brake calliper mounting bracket.

Position of connector (if applicable):

Under the right side fairing.

Pin-out:

- PIN1 - Power feed negative/Signal negative (yellow)
- PIN2 - Power feed positive/Signal positive (yellow/brown)

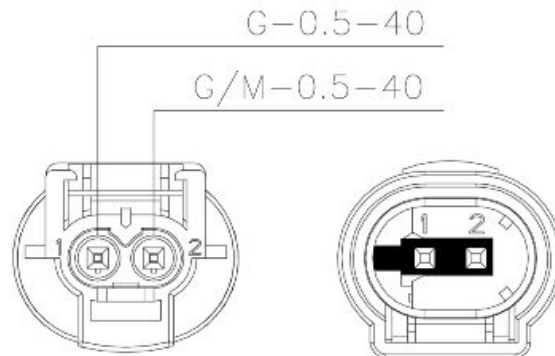

DIAGNOSTIC TOOL

Parameters:

Speed (km/h) - Rear wheel speed

DIAGNOSTIC TOOL: ELECTRICAL ERRORS

C1024 Comparison between the front and rear wheel

Electrical diagnosis:

Excessive difference.

Error cause

- Incorrect wheel or tone wheel dimensions.

Troubleshooting

- Check the type and dimensions of the installed tyres.
- Check the type and dimensions of the installed tone wheels.

C1031 Rear wheel speed sensor

Electrical diagnosis:

Open circuit, short circuit to negative or short circuit to positive.

Error cause:

- Open circuit: circuit interruption detected.
- Short-circuit to negative: null voltage detected on PIN 14 of the ABS control unit.
- Short-circuit to positive: excessive voltage detected on PIN 14 of the ABS control unit.

Troubleshooting:

Open circuit:

- Check the connectors on the component and on the ABS control unit.
- Check the integrity and continuity of the wiring harnesses:
 - between PIN 14 of the ABS control unit and PIN 1 of the sensor (yellow cable)
 - between PIN 13 of the ABS control unit and PIN 2 of the sensor (yellow/brown cable)

Short-circuit to negative:

- Disconnect the sensor connector.
- Check the ground insulation of the two PINS.
- If there is no insulation, restore the wiring harness or replace the sensor.

Short-circuit to positive:

- Disconnect the sensor connector.
- Check the battery supply insulation of the two PINS.
- If there is no insulation, restore the wiring harness or replace the sensor.

P2158 Rear wheel speed sensor/signal

- Connect to the ABS control unit diagnosis.

DIAGNOSTIC TOOL: LOGIC ERRORS**C1032 Rear wheel speed sensor****Functional diagnosis:**

Signal not plausible.

Error cause:

- Possible tone wheel fault due to deformations or dirt.

Troubleshooting:

- Check that the tone wheel is not damaged and is clean.
- Check that the number of teeth on the tone wheel is correct.
- Check that the tone wheel and the sensor are correctly positioned;
- Check that the tyre is the correct size.
- If all these checks are positive, replace the sensor.

P2162 Wheel speed plausibility**Error cause:**

- ABS system malfunction

Troubleshooting:

- Connect to the ABS control unit diagnosis.

Engine rpm sensor

Function

indicates the position and speed of the crankshaft at the Marelli control unit

Operation / Operating principle

Inductive sensor: sinusoidal-type generated voltage; two teeth are missing on the flywheel for the reference position

Level in electrical circuit diagram:

Engine speed sensor

Position:

- on the vehicle: on the clutch cover
- connector: under fuel tank on RH side (3 pin black connector)

Electrical specifications:

0.79 kohm at ambient temperature

Pin out:

1. positive signal
2. negative signal
3. shielding with earth connection

DIAGNOSTIC TOOL:PARAMETERS

Engine rpm:rpm

CAUTION

BEFORE CARRYING OUT ANY TROUBLESHOOTING, CAREFULLY READ THE GENERAL TROUBLESHOOTING CONCEPTS FOR ELECTRICAL DEVICES AT THE BEGINNING OF THE CHECK AND CONTROL SECTION IN THE ELECTRICAL SYSTEM CHAPTER.

DIAGNOSTIC TOOL: STATUSES

Synchronised panel

- No_in analysis_awaiting_Yes

DIAGNOSTIC TOOL: ELECTRICAL ERRORS

CAUTION

NO ERROR IS GENERATED IF THE ELECTRICAL CIRCUIT IS INTERRUPTED OR SHORT CIRCUITED. CARRY OUT THE MARELLI CONTROL UNIT AND RPM SENSOR CONNECTORS CHECK PROCEDURE: IF THE CONNECTORS ARE NOT OK, REPAIR OR REPLACE THEM AS NECESSARY, IF THEY ARE OK CHECK THE SENSOR CONFORMS TO THE ELECTRICAL SPECIFICATIONS: IF NECESSARY, REPLACE THE SENSOR, IF IT IS OK, CHECK THE CONTINUITY ON THE TWO CABLES, VERIFYING THAT THEY ISOLATED FROM THE POWER SUPPLY AND EARTH. CARRY OUT THE TESTS ON THE CONNECTOR OF THE SENSOR TOWARDS THE SEN-

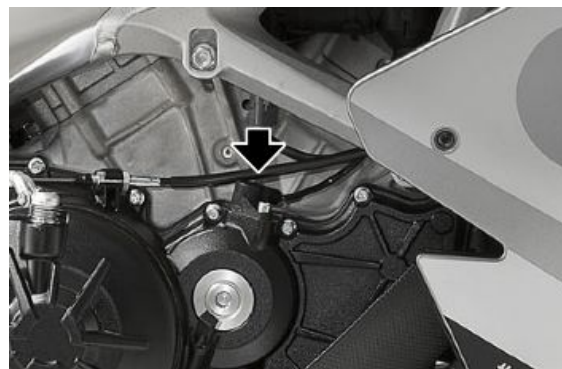
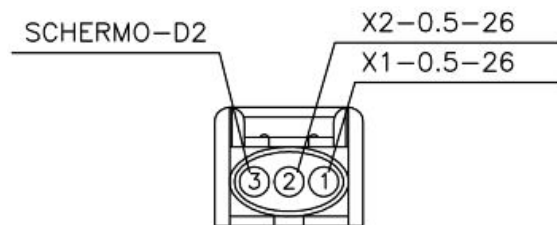

SOR, IF IT IS NOT OK REPAIR THE WIRING/REPLACE THE SENSOR, IF IT IS OK, CARRY OUT THE TEST ON PINS 20 TO 35 OF THE MARELLI CONTROL UNIT ENGINE CONNECTOR.

DIAGNOSTIC TOOL: LOGIC ERRORS

P0336 Engine rpm sensor

Functional diagnosis:

- Signal not plausible

Error causes:

- Potential false contact in the electrical circuit detected at PIN 20 - 35 of the marelli control unit ENGINE connector

This error is indicated by lighting up in a fixed manner the general warning light.

Troubleshooting:

- Check the integrity of the electrical circuit, the cleanliness of the flywheel teeth and the correct positioning of the sensor in its seat: if not ok restore; if ok, replace the sensor.

NOTE

THIS ERROR GENERATES THE RECOVERY STATUS AND ENGINE SHUT-DOWN.

Twistgrip position sensor

Function

The handle command is used to convert the driver's power demand to an electrical signal to be sent to the electronic control unit.

Operation / Operating principle

in the handle command there is an integrated double track potentiometer through which the torque demand is read (and verified). The potentiometer is watertight and magnetically controlled (contactless), it cannot be overhauled or replaced.

Level in electrical circuit diagram

Check of the throttle valves and handle sensor

Position:

- on the vehicle: integrated in the handle command
- connector: next to the thermal valve

Electrical specifications:

- -

Pin-out

1. A track power supply (orange/white cable)
2. Sensors 1 ground (green/black cable)
3. A track signal (yellow cable)
4. B track power supply (orange/black cable)
5. Sensors 2 ground (pink/black cable)

6. B track signal (light blue cable)

DIAGNOSTIC TOOL: ELECTRICAL ERRORS

P0225 Track A handle position sensor

Electrical diagnosis:

- short circuit to positive / open circuit, short circuit to negative

Error cause

- Short-circuit to positive: an excessive voltage was detected at PIN 39 of the ENGINE connector.
- If open circuit, short circuit to negative: a voltage equal to zero was detected at PIN 39 of the ENGINE connector.

This error is indicated by flashing the general warning light and by lighting up in a fixed manner the MI warning light.

Troubleshooting

- Short-circuit to positive: check the value indicated by the parameter handle position sensor track A: disconnect the connector and read the value indicated by the diagnostic tool: if the voltage does not vary, there is a short circuit on the wiring harness of the relative cable, if the voltage goes to zero, replace the handle sensor.
- open circuit, short circuit to negative: check the handle sensor connector and engine control unit connector, if not ok restore, if ok check cable continuity between the two terminals, if not ok restore, if ok check the ground insulation of the cable (from the handle sensor connector or control unit connector): if not ground insulated, restore the wiring harness, if ground insulated check, with key ON, that power supply is present at PIN 1 of the potentiometer and that the ground is present at PIN 2, if present correctly replace the handle sensor, if not present check the continuity of the malfunctioning cable: if the continuity is present replace the control unit, if not present replace the wiring harness

P2130 Track B handle position sensor

Electrical diagnosis:

- short circuit to positive / open circuit, short circuit to negative

Error cause

- Short-circuit to positive: an excessive voltage was detected at PIN 13 of the ENGINE connector.
- If open circuit, short circuit to negative: voltage equal to zero was detected at PIN 13 of the ENGINE connector

This error is indicated by flashing the general warning light and by lighting up in a fixed manner the MI warning light

Troubleshooting

- short circuit to positive: check the value indicated by the parameter handle position sensor track B: disconnect the connector and read the value indicated by the diagnostic tool: if the voltage does not vary, there is a short circuit on the wiring harness of the relative cable, if the voltage goes to zero, replace the handle sensor.
- open circuit, short circuit to negative: check the handle sensor connector and Marelli control unit connector, if not ok restore, if ok check cable continuity between the two terminals, if not ok restore, if ok check the ground insulation of the cable (from the handle sensor connector or control unit connector): if not ground insulated, restore the wiring harness, if ground insulated check, with key ON, that power supply is present at PIN 4 of the potentiometer and that the ground is present at PIN 5, if present correctly replace the handle sensor, if not present check the continuity of the malfunctioning cable: if the continuity is present replace the control unit, if not present replace the wiring harness

DIAGNOSTIC TOOL: LOGIC ERRORS**P1227 Tracks A-B handle position sensor****Functional diagnosis:**

- Signal not congruent

Error cause:

- Detected two voltages signals at PIN 39 and 13 of the ENGINE connector (tracks A-B)

This error is indicated by flashing the general warning light and by lighting up in a fixed manner the MI warning light.

Troubleshooting:

- Check the parameters for the track A and track B Handle position sensor. The values detected on track A must be comprised between 1 V (gas throttle completely closed) and 4 V (gas throttle completely open). The values detected on track B must be comprised between 0.5 V (gas throttle completely closed) and 2 V (gas throttle completely open). If one of these values differs significantly from the indicated value, it means that the potentiometer is faulty. check the handle sensor connector and control unit connector; if not OK, restore. If OK, check that cable resistance between the handle sensor cable and the control unit is a few tenths of Ohm; otherwise, restore the wiring harness; if ok, replace the complete handle command.
-

Intake pressure sensor

Function

The pressure sensors (one per bank), are fundamental for calculation of generated torque, for calculation of ambient pressure and for correct ignition timing during start-up.

Operation / operating principle

Diaphragm sensor which translates the diaphragm position into electrical voltage when in contact with the intake air.

Level in wiring diagram:

Intake air temperature sensor

Location:

- on the vehicle: sensor for rear cylinders (1 and 3) on the right of the filter box, sensor for front cylinders (2 and 4) on the left of the filter box.
- connector: on the sensor.

Electrical specifications: -

Pin out:

1. Power supply 5V
2. Ground connection
3. Output signal

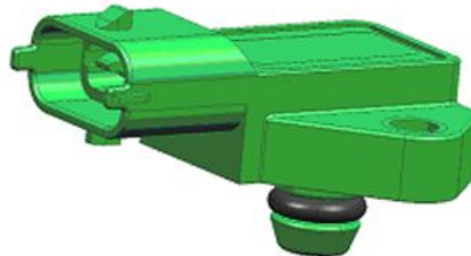
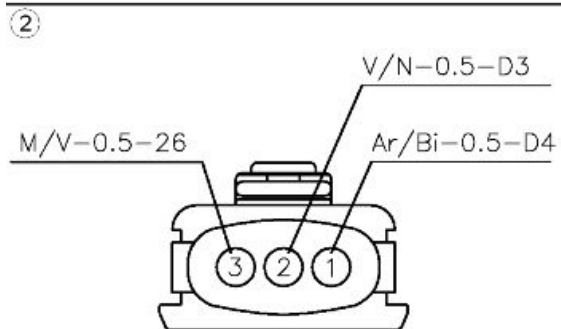
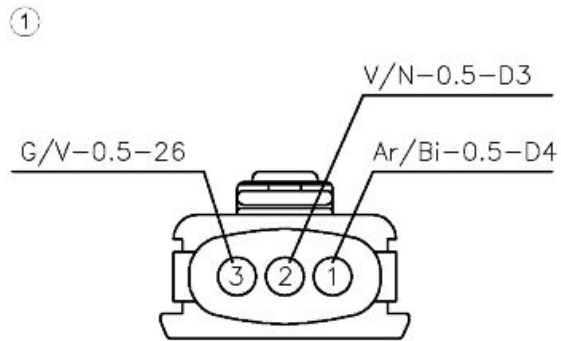

DIAGNOSIS INSTRUMENT: PARAMETERS

Front Cylinder Intake Pressure (2 and 4)

- Example value with key ON: 1003 mbar
- Example value with engine on: 720 mbar
- NOTE: pressure read by the front sensor

Rear Cylinder Intake Pressure (1 and 3)

- Example value with key ON: 1004 mbar
- Example value with engine on: 715 mbar
- NOTE: pressure read by the rear sensor

Front Cylinder estimated Intake Pressure (2 and 4)

- Example value with key ON: 1003 mbar
- Example value with engine on: 721 mbar

- NOTE: pressure estimated by the control unit according to the throttle position

Rear Cylinder estimated Intake Pressure (1 and 3)

- Example value with key ON: 1004 mbar
- Example value with engine on: 735 mbar
- NOTE: pressure estimated by the control unit according to the throttle position

CAUTION

BEFORE CARRYING OUT ANY TROUBLESHOOTING, CAREFULLY READ THE GENERAL TROUBLESHOOTING CONCEPTS FOR ELECTRICAL DEVICES AT THE BEGINNING OF THE CHECK AND CONTROL SECTION IN THE ELECTRICAL SYSTEM CHAPTER.

DIAGNOSTIC TOOL: ELECTRICAL ERRORS

Rear bank air pressure sensor P0105

- short circuit to positive / open circuit, short circuit to negative, signal not plausible.

Error cause

- Short-circuit to positive: excessive voltage has been detected on PIN 24. If open circuit, short circuit to negative: voltage equal to zero detected at PIN 24.

Troubleshooting

- Short-circuit to positive: see that the parameter of the rear cylinders air Pressure Sensor on the diagnostic tool reads approx. 1,200 mbar; disconnect the sensor connector: if the value does not change, this means there is a short circuit in the cable between the control unit connector and the sensor connector, restore the wiring harness; if the value changes, replace the sensor.
- If open circuit, short circuit to negative: check the Marelli control unit connector and the sensor connector; if not ok restore, if everything is OK, with key OFF, check the continuity between Marelli control unit connector PIN 24 and sensor connector PIN 3: if there is no continuity, restore the wiring harness, if there is continuity, check the ground insulation of the cable: if there is continuity to ground, restore the wiring harness, if there is no continuity, check (with key in ON position) that there is a voltage of approx. 5 V present at PIN 1 on the sensor connector: if not ok turn the key to OFF and check continuity between ENGINE connector PIN 25 and PIN 1 on the sensor connector: if not OK, restore the wiring harness; if OK, replace the control unit; if a voltage of 5 V is present at PIN 1, check (with key in ON position) for continuity between PIN 3 on the sensor connector and ground: if not OK, restore the wiring harness; if OK, replace the sensor.

Front bank air pressure sensor P1105

- short circuit to positive / open circuit, short circuit to negative, signal not plausible.

Error cause

- Short-circuit to positive: excessive voltage has been detected on PIN 49. If open circuit, short circuit to negative: voltage equal to zero detected at PIN 49.

Troubleshooting

- Short-circuit to positive: check on the diagnostic tool if the parameter of the rear cylinders air Pressure Sensor reads approx. 1,200 mbar; disconnect the sensor connector: if the value does not change, this means there is a short circuit in the cable between the control unit connector and the sensor connector, restore the wiring harness; if the value changes, replace the sensor.
- If open circuit, short circuit to negative: check the Marelli control unit connector and the sensor connector; if not ok restore, if everything is OK, with key OFF, check the continuity between Marelli control unit connector PIN 49 and sensor connector PIN 3: if there is no continuity, restore the wiring harness, if there is continuity, check the ground insulation of the cable: if there is continuity to ground, restore the wiring harness, if there is no continuity, check (with key in ON position) that there is a voltage of approx. 5 V present at PIN 1 on the sensor connector: if not ok turn the key to OFF and check continuity between ENGINE connector PIN 25 and PIN 1 on the sensor connector: if not OK, restore the wiring harness; if OK, replace the control unit; if a voltage of 5 V is present at PIN 1, check (with key in ON position) for continuity between PIN 3 on the sensor connector and ground: if not OK, restore the wiring harness; if OK, replace the sensor.

DIAGNOSTIC TOOL: LOGIC ERRORS

Rear bank air pressure sensor P0106

- signal not plausible.

Error cause

- An average value of the intake pressure is estimated based on the engine operating data (rpm, throttle valve, ...): if the read value differs with a certain percentage, then this error is activated. The most frequent cases can be: abnormal resistance in the sensor circuit (for example, rusted terminals) or sensor with poor performance.

Troubleshooting

- check the Marelli control unit connector and the sensor connector; if not OK, restore. If everything is OK, check that resistance between VEHICLE connector PIN 24 and sensor connector PIN 3 is a few tenths of an Ohm; if it is above that value, restore cable harness. Replace the sensor if it is correct.

Front bank air pressure sensor P1106

- signal not plausible.

Error cause

- An average value of the intake pressure is estimated based on the engine operating data (rpm, throttle valve, ...): if the read value differs with a certain percentage, then this error is

activated. The most frequent cases can be: abnormal resistance in the sensor circuit (for example, rusted terminals) or sensor with poor performance.

Troubleshooting

- Check the filter box large connector, the Marelli control unit connector and the sensor connector; if not OK, restore. If everything is OK, check that resistance between VEHICLE connector PIN 49 and sensor connector PIN 3 is a few tenths of an Ohm; If it is above that value, restore cable harness. Replace the sensor if it is correct.

Error for unexpected air intake in the rear cylinder manifold P1600

- signal not plausible.

Error cause

- Small difference detected between the estimated pressure and the measured pressure: the measured pressure is higher than the estimated one (for example, the pipe between sensor and throttle body is squashed or there is a hole in the intake manifold).

Troubleshooting

- Check the pneumatic system between the pressure sensor and the socket to read pressure on the throttle body; check that the intake manifold is in good conditions and the pressure reading hole is clean.

Error for unexpected air intake in the front cylinder manifold P1601

- signal not plausible.

Error cause

- Small difference detected between the estimated pressure and the measured pressure: the measured pressure is higher than the estimated one (for example, the pipe between sensor and throttle body is squashed or there is a hole in the intake manifold).

Troubleshooting

- Check the pneumatic system between the pressure sensor and the socket to read pressure on the throttle body; check that the intake manifold is in good conditions and the pressure reading hole is clean.

Rear bank intake manifold pressure estimate error P1602

- pressure too high/pressure too low.

Error cause

- A substantial difference between the estimated pressure and the measured pressure has been detected (for example, the pipe between sensor and throttle body is fully detached/clogged or squashed).

Troubleshooting

- Check the pneumatic system between the pressure sensor and the socket to read pressure on the throttle body; check that the intake manifold is in good conditions and the pressure reading hole is clean: there is a very evident defect in the intake and pressure reading system.

Front bank intake manifold pressure estimate error P1603

- pressure too high/pressure too low.

Error cause

- A substantial difference between the estimated pressure and the measured pressure has been detected (for example, the pipe between sensor and throttle body is fully detached/clogged or squashed).

Troubleshooting

- Check the pneumatic system between the pressure sensor and the socket to read pressure on the throttle body; check that the intake manifold is in good conditions and the pressure reading hole is clean: there is a very evident defect in the intake and pressure reading system.
-

Rear bank manifold pressure too low error P1604

- signal not plausible.

Error cause

- Small difference detected between the estimated pressure and the measured pressure: the measured pressure is below the estimated one (for example, smeared throttle body).

Troubleshooting

- Check the pneumatic system between the pressure sensor and the socket to read pressure on the throttle body; check that the intake manifold is in good conditions and the pressure reading hole is clean.

Front bank manifold pressure too low error P1605

- signal not plausible.

Error cause

- Small difference detected between the estimated pressure and the measured pressure: the measured pressure is below the estimated one (for example, smeared throttle body).

Troubleshooting

- Check the pneumatic system between the pressure sensor and the socket to read pressure on the throttle body; check that the intake manifold is in good conditions and the pressure reading hole is clean.
-

Engine temperature sensor

Function

It is used to indicate to the control unit the engine temperature, to optimise its behaviour and to calculate the engine friction for a better estimation of the delivered torque.

Operation / Operating principle

NTC type sensor (resistance sensor, inversely variable with temperature).

Level in electrical circuit diagram:

Temperature sensors

Position:

- on the vehicle: on the right side, next to the two big ends.
- connector: on the sensor.

Electrical specifications:

- Resistance at 25°: $2.05 \text{ k}\Omega \pm 100/\Omega$
- Resistance at 60°: $575 \Omega \pm 15 /\Omega$
- Resistance at 90°: $230 \Omega \pm 5 /\Omega$

Pin out:

1. Greek/Black: Ground
2. Black
3. Yellow/Brown: 0-5 V signal
4. Black

DIAGNOSTIC TOOL: PARAMETERS

Engine temperature:

- Example value with key ON: 25° C
- Example value with engine on: 75° C
- This is one of the values set by the ECU in the event of recovery mode: if there is a malfunction after the engine start-up, the temperature is raised up to approximately 75°.

Engine temperature before Recovery:

- Example value with key ON: -40° C
- Example value with engine on: -40° C
- Value determined from the signal read without taking into consideration the recovery mode: the illustrative value refers to an open circuit.

Engine temperature at start-up:

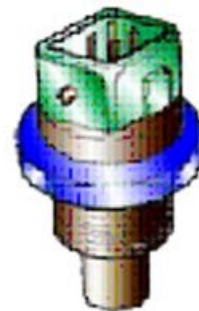
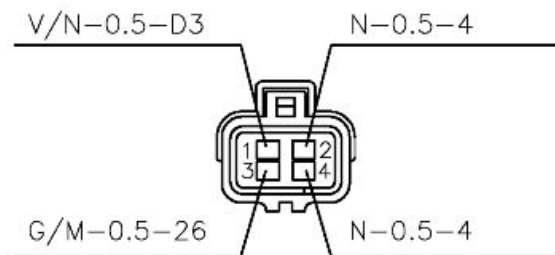

- Example value with key ON: -40° C
- Example value with engine on: 25° C
- The value of the engine start-up temperature is saved. At key ON, the value -40°C is read.

CAUTION

BEFORE CARRYING OUT ANY TROUBLESHOOTING, CAREFULLY READ THE GENERAL TROUBLESHOOTING CONCEPTS FOR ELECTRICAL DEVICES AT THE BEGINNING OF THE CHECK AND CONTROL SECTION IN THE ELECTRICAL SYSTEM CHAPTER.

DIAGNOSTIC TOOL: ELECTRICAL ERRORS**P0115 Engine temperature sensor**

- open circuit, shorted to positive / shorted to negative.

Error cause

- If open circuit, short circuit to positive: an excessive voltage was detected at PIN 12 of the ENGINE connector. If short circuit to negative: voltage equal to zero has been detected. The instrument panel indicates this error by lighting up in a fixed manner the MI warning light.

Troubleshooting

- If open circuit, short circuit to positive: check the sensor connector and the Marelli control unit connector. If they are OK, check sensor continuity: replace the sensor if not OK; if OK, check continuity between the ENGINE connector PIN 12 and the sensor PIN 3: If continuity is absent, restore the wiring harness; if ok reconnect the control unit connector and with key ON check the continuity between PIN 1 of the sensor connector and vehicle ground: if OK, it means that the error is caused by the cable being shorted to positive and it is necessary to restore the cable harness between ENGINE PIN 12 and sensor PIN 3; if there is no continuity to ground, check the sensor connector and the Marelli control unit connector. If not OK, restore the cable harness. If OK, check for continuity between the ENGINE connector PIN 6 or 17 and the sensor connector PIN 1: restore the cable harness if there is not continuity. If there is, it means that the control unit does not supply the ground connection and therefore should be replaced.
- If short circuit to negative, check the correct resistance of the sensor: if resistance is null, replace the sensor; if resistance is correct, it means that the Yellow/Brown cable has ground connection: restore the cable harness

DIAGNOSTIC TOOL: LOGIC ERRORS**P0116 Engine temperature sensor**

Signal not plausible.

Error cause

- An excessive temperature variation was detected: the cause could be a contact resistance between the terminals, for example. The instrument panel indicates this error by lighting up in a fixed manner the MI warning light.

Troubleshooting

- Check the sensor connector and the ENGINE connector of the Marelli control unit.

NOTES

No error is detected if the sensor does not work correctly or the control unit connector or sensor terminals are rusty: then use the diagnostic tool to check if the temperature indicated is the same as the engine temperature. Check also that the sensor electrical characteristics are observed: replace the sensor if not OK; if it is OK, check the sensor connector and the Marelli control unit connector.

Air temperature sensor**Function**

indicates to the control unit the temperature of the intake air, used to calculate the oxygen, to optimise the required fuel quantity for the correct combustion

Operation / Operating principle

NTC type sensor (resistance sensor, inversely variable with temperature)

Level in the electrical circuit diagram:

Temperature sensors

Position:

- sensor: on the rear side of the filter housing
- connector: on the sensor

Electrical specifications:Resistance

- at 0 °C (32 °F): 32.5 kΩ ± 5%
- at 25 °C (77 °F): 10.0 kΩ ± 5%

Pin out:

1. 0-5 V signal
2. Ground

DIAGNOSTIC TOOL:PARAMETERS**Air temperature**

Example value with key ON: 26 °C (78.8 °F):

This is one of the values set by the ECU in the event of recovery mode

Air temperature before Recovery

Example value with key ON: -40 °C (-40.0 °F):

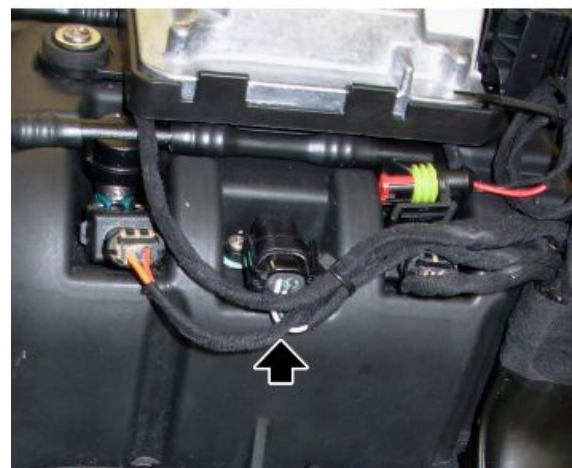
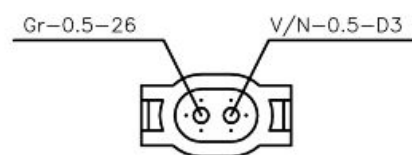

Value determined from the signal read without taking into consideration the recovery mode: the illustrative value refers to an open circuit

CAUTION

BEFORE CARRYING OUT ANY TROUBLESHOOTING, CAREFULLY READ THE GENERAL TROUBLESHOOTING CONCEPTS FOR ELECTRICAL DEVICES AT THE BEGINNING OF THE CHECK AND CONTROL SECTION IN THE ELECTRICAL SYSTEM CHAPTER.

DIAGNOSTIC TOOL: ELECTRICAL ERRORS**P0110 Air temperature sensor**

- open circuit, short circuit to positive / short circuit to negative

Error cause

- If open circuit, short circuit to positive: an excessive voltage was detected at PIN 37 of the ENGINE connector. If short circuit to negative: zero voltage detected. The instrument panel indicates this error by lighting up in a fixed manner the MI warning light.

Troubleshooting

- If open circuit, short circuit to positive: check the sensor connector and the Marelli control unit connector. If they are OK, check sensor continuity: replace the sensor if not OK; if OK, check continuity between the ENGINE connector PIN 37 and the sensor PIN 1: If continuity is absent, restore the wiring harness; if ok reconnect the control unit connector and with key ON check the continuity between PIN 2 of the sensor connector and vehicle ground: if OK, it means that the error is caused by the cable being shorted to positive and it is necessary to restore the cable harness between ENGINE PIN 37 and sensor PIN 1; check the sensor connector and the Marelli control unit connector. If not OK, restore the cable harness. If OK, check for continuity between the ENGINE connector PIN 6 or 17 and the sensor connector PIN 2: restore the cable harness if there is no continuity. If there is, it means that the control unit does not supply the ground connection and therefore should be replaced
- If short circuit to negative, check the correct resistance of the sensor: if the resistance is null, replace the sensor; if the resistance is correct, it means that the Grey cable has ground connection: restore the cable harness

Lambda sensor

(FRONT CYLINDER BANK)

Function

In charge of telling the control unit whether the mixture is lean or rich

Operation / Operating principle

The Marelli injection control unit reads and interprets a voltage generated by the difference in oxygen content between the exhaust fumes and the ambient. It does not require an external supply source but, in order to work properly, it should reach a high operating temperature: that is why there is a heating circuit inside

Level in electrical circuit diagram:

Lambda probe

Position:

- on manifold: left side of the vehicle
- connector: left side of the vehicle, fixed to the support bracket of the fairing lug (4-way connector black)

Electrical specifications

- Heater circuit: 7-9Ω at ambient temp.

Pin out:

1. Sensor signal + (black wire)
2. Sensor signal - (grey wire)
3. Heater ground connection (white cable)
4. Heater power supply (white cable)

DIAGNOSTIC TOOL:PARAMETERS

Lambda probe

- Example value with key ON: about 3300 mV
- Example value with engine on: 100-1000 mV

If there is a short circuit at + 5 V or higher, the lambda probe parameter is not equal to the value

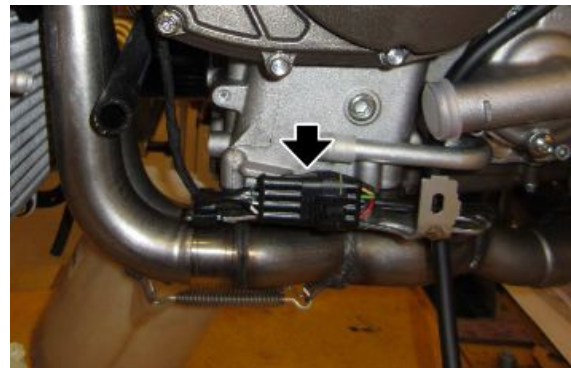

read by the control unit, but a recovery value is displayed

Lambda correction

- Example value with key ON: 0 %
- Example value with engine on: -10% / +10%

In closed loop, the value must be close to 1.00 (values not within the -15% / +15% interval indicate a fault). In an open circuit, the lambda probe signal is too low. Therefore, the control unit takes it as a lean mixture condition and will try to enrich it. The value read will be +25%: once this value is reached and kept unchanged for a certain time, the function diagnosis of the lambda probe is activated with following deactivation of it.

This diagnosis is activated when the correction constantly arrives -25%.

CAUTION

BEFORE CARRYING OUT ANY TROUBLESHOOTING, CAREFULLY READ THE GENERAL TROUBLESHOOTING CONCEPTS FOR ELECTRICAL DEVICES AT THE BEGINNING OF THE CHECK AND CONTROL SECTION IN THE ELECTRICAL SYSTEM CHAPTER.

DIAGNOSTIC TOOL: STATUSES

Lambda probe: Start-up_Lean_Rich_Fault due to rich titre_Fault due to lean air-fuel mixture

- If the probe connector is disconnected (voltage almost equal to zero) it switches to the state of Fault due to lean air-fuel mixture

Lambda check: Open loop/Closed loop/Rich in closed loop/Lean in closed loop/enriched

- Closed loop indicates that the control unit is using the lambda probe signal to keep the combustion as close as possible to the stoichiometric value.

DIAGNOSTIC TOOL: ACTIVATIONS

Lambda probe heater

- The injection relay (No. 33 in the electrical circuit diagram, placed under the saddle next to the battery positive, CHECK, however, the identification of the relay with the colour of the cables) is energised and the heating circuit is closed to ground 5 times (pin 3 of the Lambda probe connector). Electrical continuity is required in the wiring for the relay to activate correctly: no errors are generated in case of no activation.

DIAGNOSTIC TOOL: ELECTRICAL ERRORS

P0150 Front bank lambda probe

Electrical diagnosis:

- Short circuit to positive

Error cause:

- Excessive voltage detected (battery voltage) at PIN 9 and 38 of the ENGINE connector.
Caution: the "lambda probe" parameter is not the actual read value but a recovery value is displayed.

The instrument panel indicates this error by lighting up in a fixed manner the MI warning light.

Troubleshooting:

- Short-circuit to positive: with key set to ON, disconnect the sensor connector and measure PIN 1 voltage on the cable harness side (yellow/orange cable): if the voltage (5 or 12 V) is present, restore the wiring harness, if the voltage is absent replace the lambda probe

P0155 Front bank lambda probe heating**Electrical diagnosis:**

- short circuit to positive/ open circuit, short circuit to negative

Error cause:

- Short-circuit to positive: an excessive voltage was detected at PIN 44 of the ENGINE connector.
- If open circuit, short circuit to negative: a voltage equal to zero was detected at PIN 44 of the ENGINE connector.

The instrument panel indicates this error by lighting up in a fixed manner the MI warning light.

Troubleshooting:

- Short-circuit to positive: disconnect the probe connector and check the correct sensor resistance: if NOT OK, replace the sensor, if OK, restore the wiring harness (Black/Violet cable).
- If open circuit, short circuit to negative: check the continuity from the probe connector (PIN 3 and 4) to the probe: if NOT OK, replace the probe; if ok, perform the check procedure for the sensor connector and for the Marelli control unit connector: if NOT OK restore; if OK, with the key ON and the sensor connector disconnected, check if there is battery voltage at PIN 4: if NOT OK, check the continuity of the Red//Brown cable between the probe connector and the injection relay (no. 33 in the electrical circuit diagram, position under the saddle, close to the battery positive; however, CHECK the relay identification with the cable colours); if there are also errors regarding the coils, lower and upper injectors and secondary air, check the relay and its energy and power line; if there is voltage at PIN 4, check ground insulation of the Black/Violet cable (PIN 3): if NOT OK, restore the wiring harness; if OK, check the continuity of the Black/Violet cable (between PIN 3 of the sensor connector and ENGINE PIN 44) and restore the wiring harness.

WARNING

The control unit does not detect the following malfunctions of the lambda probe circuit relative to the signal: interrupted circuit, short circuit to ground or malfunction of the sensor (for ex-

ample, voltage not variable). If the indication is abnormal, perform the troubleshooting indicated below.

Troubleshooting

- Check the continuity of the circuit from the probe connector (PIN 1 and PIN 2) towards the probe: replace the lambda probe if there is no continuity; if there is continuity, check the sensor connector and the Marelli control unit connector: if NOT OK, restore; if OK, check the continuity between the ENGINE connector PIN 9 and PIN 38 and restore the wiring harness.

DIAGNOSTIC TOOL: LOGIC ERRORS

P0154 Front bank lambda probe

Functional diagnosis:

- no switching from high / no switching from low

Error cause:

- If no switching from high: is shown when the ratio control is in closed loop and when the secondary air valve is not operating. The error is validated if the engine is in CUTOFF status and the probe signal is close to 1V, or if the engine is in another operating condition that requires the injection but the switching from the "HIGH RATIO" to "LOW RATIO" is missing for a certain "adjusted" number of dead points (PMS or TDC).
- If no switching from low: is shown when the ratio control is in closed loop and when the secondary air valve is not operating. The error is validated if during the ratio control stage, the switching from "HIGH RATIO" to "LOW RATIO" is missing for a certain "adjusted" number of upper dead points (PMS or TDC).

The instrument panel indicates this error by lighting up in a fixed manner the MI warning light.

Troubleshooting:

- If no switching from high: the fault may be generated in the supply system (poor pin sealing) or in the probe. Check the wiring harness. if NOT OK restore; if OK, replace the lambda probe.
- If no switching from low: the fault may be generated in the supply system (dirty injector, low fuel supply system pressure) or in the probe. Check the wiring harness. if NOT OK restore; if OK, replace the lambda probe.
- For the (non polarised) type of probes, this error may be caused also by a short circuit to the wiring harness ground.

NOTE

THIS ERROR DISABLES THE RATIO CONTROL IN CLOSED LOOP.

(REAR CYLINDER BANK)**Function**

In charge of telling the control unit whether the mixture is lean or rich

Operation / Operating principle

The Marelli injection control unit reads and interprets a voltage generated by the difference in oxygen content between the exhaust fumes and the ambient. It does not require an external supply source but, in order to work properly, it should reach a high operating temperature: that is why there is a heating circuit inside

Level in electrical circuit diagram:

Lambda probe

Position:

- on manifold: on the rear part of the vehicle in correspondence with the shock absorber
- connector: on the right of the pinion cover (4-ways black connector)

Electrical specifications

- Heater circuit: 7-9 Ω at ambient temp.

Pin out:

1. Sensor signal + (black wire)
2. Sensor signal - (grey wire)
3. Heater ground connection (white cable)
4. Heater power supply (white cable)

DIAGNOSTIC TOOL:PARAMETERS

Lambda probe

- Example value with key ON: about 3300 mV
- Example value with engine on: 100-1000 mV

If there is a short circuit at + 5 V or higher, the lambda probe parameter is not equal to the value

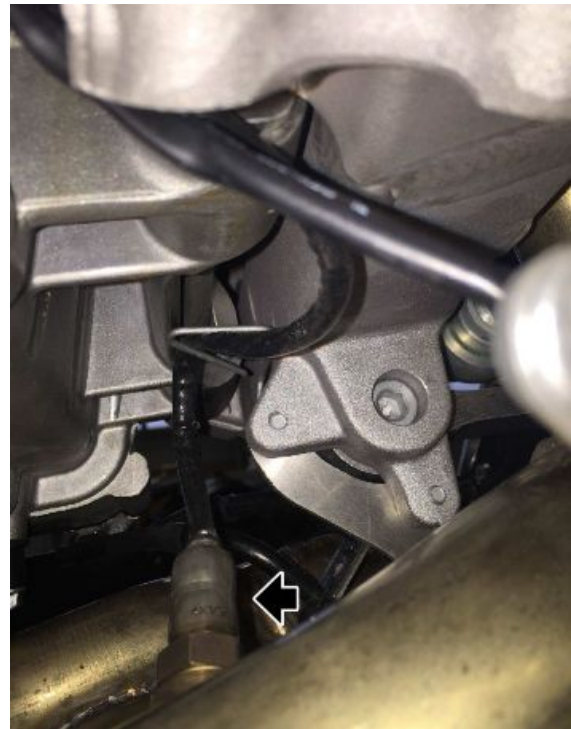

read by the control unit, but a recovery value is displayed

Lambda correction

- Example value with key ON: 0 %
- Example value with engine on: -10% / +10%

In closed loop, the value must be close to 1.00 (values not within the -15% / +15% interval indicate a fault). In an open circuit, the lambda probe signal is too low. Therefore, the control unit takes it as a lean mixture condition and will try to enrich it. The value read will be +25%: once this value is reached and remains unchanged for a certain time, the lambda probe functional diagnosis is activated, resulting in it being deactivated.

This diagnosis is activated when the correction constantly arrives -25%.

CAUTION

BEFORE CARRYING OUT ANY TROUBLESHOOTING, CAREFULLY READ THE GENERAL TROUBLESHOOTING CONCEPTS FOR ELECTRICAL DEVICES AT THE BEGINNING OF THE CHECK AND CONTROL SECTION IN THE ELECTRICAL SYSTEM CHAPTER.

DIAGNOSTIC TOOL: STATUSES

Lambda probe: Start-up_Lean_Rich_Fault due to rich titre_Fault due to lean air-fuel mixture

- If the probe connector is disconnected (voltage almost equal to zero) it switches to the state of Fault due to lean air-fuel mixture

Lambda check: Open loop/Closed loop/Rich in closed loop/Lean in closed loop/enriched

- Closed loop indicates that the control unit is using the lambda probe signal to keep the combustion as close as possible to the stoichiometric value.

DIAGNOSTIC TOOL: ACTIVATIONS

Lambda probe heater

- The injection relay (No. 33 in the electrical circuit diagram, placed under the saddle next to the battery positive, CHECK, however, the identification of the relay with the colour of the cables) is energised and the heating circuit is closed to ground 5 times (pin 3 of the Lambda probe connector). Electrical continuity is required in the wiring for the relay to activate correctly: no errors are generated in case of no activation.

DIAGNOSTIC TOOL: ELECTRICAL ERRORS

P0130 Front bank lambda probe

Electrical diagnosis:

- Short circuit to positive.

Error cause:

- Excessive voltage detected (battery voltage) at PIN 10 and 22 of the ENGINE connector. Caution: the "lambda probe" parameter is not the actual read value but a recovery value is displayed.

The instrument panel indicates this error by lighting up in a fixed manner the MI warning light.

Troubleshooting:

- Short-circuit to positive: with key ON, disconnect the sensor connector and measure the voltage at PIN 1, wiring harness side (grey cable): if the voltage (5 or 12 V) is present, restore the wiring harness, if the voltage is absent replace the lambda probe

P0135 Rear bank lambda probe heating**Electrical diagnosis:**

- short circuit to positive/ open circuit, short circuit to negative

Error cause

- Short-circuit to positive: an excessive voltage was detected at PIN 32 of the ENGINE connector.
- If open circuit, short circuit to negative: a voltage equal to zero was detected at PIN 32 of the ENGINE connector.

The instrument panel indicates this error by lighting up in a fixed manner the MI warning light.

Troubleshooting

- Short-circuit to positive: disconnect the probe connector and check the correct sensor resistance: if Not OK, replace the sensor; if OK, restore the wiring harness (Green cable)..
- If open circuit, short circuit to negative: check the continuity from the probe connector (PIN 3 and 4) to the probe: if NOT OK, replace the probe; if ok, perform the check procedure for the sensor connector and for the Marelli control unit connector: if NOT OK restore; if OK, with the key ON and the sensor connector disconnected, check if there is battery voltage at PIN 4: if NOT OK, check the continuity of the Red//Brown cable between the probe connector and the injection relay (no. 33 in the electrical circuit diagram, position under the saddle, close to the battery positive; however, CHECK the relay identification with the cable colours); if there are also errors regarding the coils, lower and upper injectors and secondary air, check the relay and its energy and power line; if there is voltage at PIN 4, check ground insulation of the green cable (PIN 3): if NOT OK, restore the wiring harness; if OK, check the continuity of the Green cable (between PIN 3 of the sensor connector and ENGINE PIN 32) and restore the wiring harness
- If open circuit, short circuit to negative: check the continuity from the probe connector (PIN 3 and 4) to the probe: if NOT OK, replace the probe; if ok, perform the check procedure for the sensor connector and for the Marelli control unit connector: if NOT OK restore; if OK,

with the key ON and the sensor connector disconnected, check if there is battery voltage at PIN 4: if NOT OK, check the continuity of the Red//Brown cable between the probe connector and the injection relay (no. 33 in the electrical circuit diagram, position under the saddle, close to the battery positive; however, CHECK the relay identification with the cable colours); if there are also errors regarding the coils, lower and upper injectors and secondary air, check the relay and its energy and power line; if there is voltage at PIN 4, check ground insulation of the green cable (PIN 3): if NOT OK, restore the wiring harness; if OK, check the continuity of the Green cable (between PIN 3 of the sensor connector and ENGINE PIN 32) and restore the wiring harness.

WARNING

The control unit does not detect the following malfunctions of the lambda probe circuit relative to the signal: interrupted circuit, short circuit to ground or malfunction of the sensor (for example, voltage not variable). If the indication is abnormal, perform the troubleshooting indicated below.

Troubleshooting

- Check the continuity of the circuit from the probe connector (PIN 1 and PIN 2) towards the probe: replace the lambda probe if there is no continuity; if there is continuity, check the sensor connector and the Marelli control unit connector: if NOT OK, restore; if OK, check the continuity between the ENGINE connector PIN 10 and PIN 22 and restore the wiring harness.

DIAGNOSTIC TOOL: LOGIC ERRORS**P0134 Rear bank lambda probe****Functional diagnosis:**

- no switching from high / no switching from low

Error cause:

- If no switching from high: is shown when the ratio control is in closed loop and when the secondary air valve is not operating. The error is validated if the engine is in CUTOFF status and the probe signal is close to 1V, or if the engine is in another operating condition that requires the injection but the switching from the "HIGH RATIO" to "LOW RATIO" is missing for a certain "adjusted" number of dead points (PMS or TDC).
- If no switching from low: is shown when the ratio control is in closed loop and when the secondary air valve is not operating. The error is validated if during the ratio control stage, the switching from "HIGH RATIO" to "LOW RATIO" is missing for a certain "adjusted" number of upper dead points (PMS or TDC).

The instrument panel indicates this error by lighting up in a fixed manner the MI warning light.

Troubleshooting:

- If no switching from high: the fault may be generated in the supply system (poor pin sealing) or in the probe. Check the wiring harness. if NOT OK restore; if OK, replace the lambda probe.
- If no switching from low: the fault may be generated in the supply system (dirty injector, low fuel supply system pressure) or in the probe. Check the wiring harness. if NOT OK restore; if OK, replace the lambda probe.
- For the (non polarised) type of probes, this error may be caused also by a short circuit to the wiring harness ground.

NOTE

THIS ERROR DISABLES THE RATIO CONTROL IN CLOSED LOOP.

Injector

Lower injectors key:

- 1. Lower Injector 1
- 2. Lower Injector 3
- 3. Lower Injector 2
- 4. Lower Injector 4

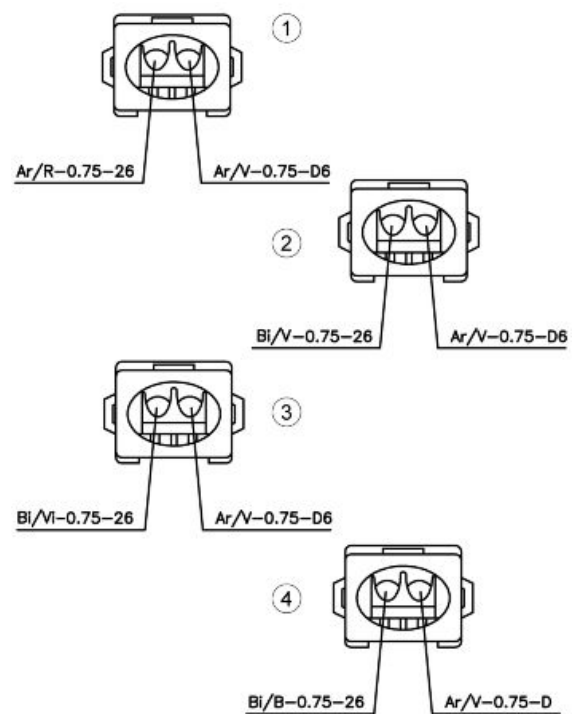

LOWER INJECTOR

Function

Provide the correct amount of fuel at the correct time. The lower injectors work in the field of low engine revs, the upper injectors in the field of high engine revs.

Operation / Operating principle

Injector coil is energised for the petrol passage to open

Level in electrical circuit diagram:

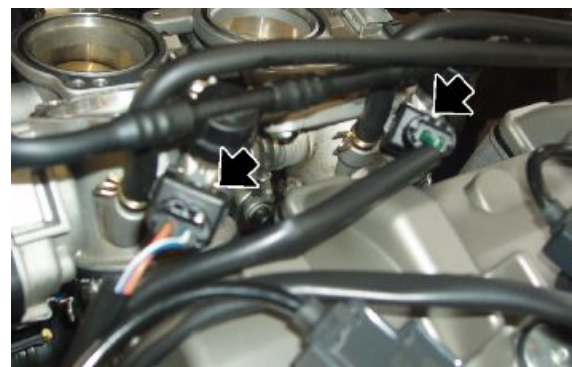

Coils and injectors

Position:

- on the vehicle: on the throttle body
- connector: on injectors

Electrical specifications:

14.8 Ω \pm 5% (at ambient temp.)

Pin out:

- "+": supply
- " ": ground

DIAGNOSTIC TOOL:PARAMETERS

Cylinder injection time 1

- Example value with engine on: 1.9 ms

Cylinder injection time 2

- Example value with engine on: 1.9 ms

Cylinder injection time 3

- Example value with engine on: 1.9 ms

Cylinder injection time 4

- Example value with engine on: 1.9 ms

CAUTION

BEFORE CARRYING OUT ANY TROUBLESHOOTING, CAREFULLY READ THE GENERAL TROUBLESHOOTING CONCEPTS FOR ELECTRICAL DEVICES AT THE BEGINNING OF THE CHECK AND CONTROL SECTION IN THE ELECTRICAL SYSTEM CHAPTER.

DIAGNOSTIC TOOL: ACTIVATIONS

Lower injector cylinder 1

- The injection relay (No. 33 in the electrical circuit diagram, placed under saddle, right side; CHECK, however, the identification of the relay with the colour of the cables) is energised for 5 seconds and the injector cable connected to control unit is closed to ground for 4 ms per second. Disconnect the 4-way connector of the fuel pump to be able to hear the relay and injector activation. Electrical continuity is required in the wiring for the relay to activate correctly: no errors are generated if the relay fails to activate

Lower injector cylinder 2

- The injection relay (No. 33 in the electrical circuit diagram, placed under saddle, right side; CHECK, however, the identification of the relay with the colour of the cables) is energised for 5 seconds and the injector cable connected to control unit is closed to ground for 4 ms per second. Disconnect the 4-way connector of the fuel pump to be able to hear the relay

and injector activation. Electrical continuity is required in the wiring for the relay to activate correctly: no errors are generated if the relay fails to activate

Lower injector cylinder 3

- The injection relay (No. 33 in the electrical circuit diagram, placed under saddle, right side; CHECK, however, the identification of the relay with the colour of the cables) is energised for 5 seconds and the injector cable connected to control unit is closed to ground for 4 ms per second. Disconnect the 4-way connector of the fuel pump to be able to hear the relay and injector activation. Electrical continuity is required in the wiring for the relay to activate correctly: no errors are generated if the relay fails to activate

Lower injector cylinder 4

- The injection relay (No. 33 in the electrical circuit diagram, placed under saddle, right side; CHECK, however, the identification of the relay with the colour of the cables) is energised for 5 seconds and the injector cable connected to control unit is closed to ground for 4 ms per second. Disconnect the 4-way connector of the fuel pump to be able to hear the relay and injector activation. Electrical continuity is required in the wiring for the relay to activate correctly: no errors are generated if the relay fails to activate

DIAGNOSTIC TOOL: ELECTRICAL ERRORS

Rear bank lower injector cylinder 1P0201

- short circuit to positive / short circuit to negative / open circuit

Error cause

- Short-circuit to positive: excessive voltage has been detected on ENGINE PIN 8. If short circuit to negative: no voltage has been detected. If open circuit: an interruption has been detected

Troubleshooting

- Short-circuit to positive: disconnect the injector connector, set key to ON, activate the component with the diagnostic tool and check the voltage on the orange/red cable on the injector connector (if present): if there is voltage, restore the filter box cable harness. If there is no voltage, replace the sensor
- If short circuit to negative: disconnect the injector connector, set the key to ON and check if there is a ground connection on the orange/red cable: if the connection is present, restore the cable harness. If there is no connection, replace the injector
- If open circuit: check the component correct electrical characteristic: if it is not the correct one, replace the component; if it is correct, check the connector on the component and the Marelli control unit connector: if not OK, restore. If OK, check cable continuity between the ENGINE PIN 8 and component PIN - and restore the cable harness

Front bank lower injector cylinder 2 P0202

- short circuit to positive / short circuit to negative / open circuit

Error cause

- Short-circuit to positive: excessive voltage has been detected on ENGINE PIN 46. If short circuit to negative: no voltage has been detected. If open circuit: an interruption has been detected

Troubleshooting

- Short-circuit to positive: disconnect the injector connector, set key to ON, activate the component with the diagnostic tool and check the voltage on the white/green cable on the injector connector: if there is voltage, restore the filter box cable harness. If there is no voltage, replace the sensor
- If short circuit to negative: disconnect the injector connector, set the key to ON and check if there is a ground connection on the white/green cable: if the connection is present, restore the cable harness. If there is no connection, replace the injector
- If open circuit: check the component correct electrical characteristic: if it is not the correct one, replace the component; if it is correct, check the connector on the component and the Marelli control unit connector: if not OK, restore. If OK, check cable continuity between the ENGINE PIN 46 and component PIN - and restore the cable harness

Rear bank lower injector cylinder 3 P0203

- short circuit to positive / short circuit to negative / open circuit

Error cause

- Short-circuit to positive: excessive voltage has been detected on ENGINE PIN 34. If short circuit to negative: no voltage has been detected. If open circuit: an interruption has been detected

Troubleshooting

- Short-circuit to positive: disconnect the injector connector, set key to ON, activate the component with the diagnostic tool and check the voltage on the White/Purple cable on the injector connector: if there is voltage, restore the filter box cable harness. If there is no voltage, replace the sensor
- If short circuit to negative: disconnect the injector connector, set the key to ON and check if there is a ground connection on the white/purple cable: if the connection is present, restore the cable harness. If there is no connection, replace the injector
- If open circuit: check the component correct electrical characteristic: if it is not the correct one, replace the component; if it is correct, check the connector on the component and the Marelli control unit connector: if not OK, restore. If OK, check cable continuity between the ENGINE PIN 34 and component PIN - and restore the cable harness

Front bank lower injector cylinder 4 P0204

- short circuit to positive / short circuit to negative / open circuit

Error cause

- Short-circuit to positive: excessive voltage has been detected on ENGINE PIN 45. If short circuit to negative: no voltage has been detected. If open circuit: an interruption has been detected

Troubleshooting

- Short-circuit to positive: disconnect the injector connector, set key to ON, activate the component with the diagnostic tool and check the voltage on the White/Blue cable on the injector connector: if there is voltage, restore the filter box cable harness. If there is no voltage, replace the sensor
- If short circuit to negative: disconnect the injector connector, set the key to ON and check if there is a ground connection on the white/blue cable: if the connection is present, restore the cable harness. If there is no connection, replace the injector
- If open circuit: check the component correct electrical characteristic: if it is not the correct one, replace the component; if it is correct, check the connector on the component and the Marelli control unit connector: if not OK, restore. If OK, check cable continuity between the ENGINE PIN 45 and component PIN - and restore the cable harness

Upper injectors key:

- 5. Upper Injector 1
- 6. Upper Injector 3
- 7. Upper Injector 2
- 8. Upper Injector 4

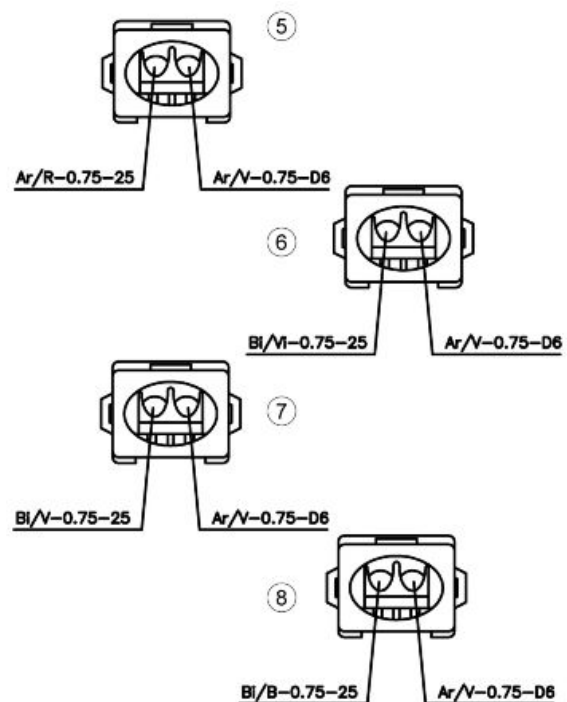

UPPER INJECTOR Function

Provide the correct amount of fuel at the correct time. The lower injectors work in the field of low engine revs, the upper injectors in the field of high engine revs.

Operation / Operating principle

Injector coil is energised for the petrol passage to open

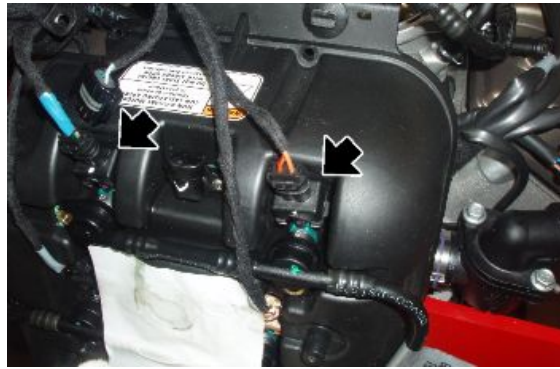
**Level in electrical circuit diagram:**

Coils and injectors

Position:

- on the vehicle: on filter box cover
- connector: on injectors

Electrical specifications:

12 +/- 0.6Ω ± 5% (at ambient temp)

Pin out:

- "+": supply
- " ": ground

CAUTION

BEFORE CARRYING OUT ANY TROUBLESHOOTING, CAREFULLY READ THE GENERAL TROUBLESHOOTING CONCEPTS FOR ELECTRICAL DEVICES AT THE BEGINNING OF THE CHECK AND CONTROL SECTION IN THE ELECTRICAL SYSTEM CHAPTER.

DIAGNOSTIC TOOL: ACTIVATIONS

Lower injector cylinder 1

- The injection relay (No. 33 in the electrical circuit diagram, placed under saddle, right side; CHECK, however, the identification of the relay with the colour of the cables) is energised for 5 seconds and the injector cable connected to control unit is closed to ground for 4 ms per second. Disconnect the 4-way connector of the fuel pump to be able to hear the relay and injector activation. Electrical continuity is required in the wiring for the relay to activate correctly: no errors are generated if the relay fails to activate

Upper injector cylinder 2

- The injection relay (No. 33 in the electrical circuit diagram, placed under saddle, right side; CHECK, however, the identification of the relay with the colour of the cables) is energised for 5 seconds and the injector cable connected to control unit is closed to ground for 4 ms per second. Disconnect the 4-way connector of the fuel pump to be able to hear the relay and injector activation. Electrical continuity is required in the wiring for the relay to activate correctly: no errors are generated if the relay fails to activate

Upper injector cylinder 3

- The injection relay (No. 33 in the electrical circuit diagram, placed under saddle, right side; CHECK, however, the identification of the relay with the colour of the cables) is energised for 5 seconds and the injector cable connected to control unit is closed to ground for 4 ms per second. Disconnect the 4-way connector of the fuel pump to be able to hear the relay and injector activation. Electrical continuity is required in the wiring for the relay to activate correctly: no errors are generated if the relay fails to activate

Upper injector cylinder 4

- The injection relay (No. 33 in the electrical circuit diagram, placed under saddle, right side; CHECK, however, the identification of the relay with the colour of the cables) is energised for 5 seconds and the injector cable connected to control unit is closed to ground for 4 ms per second. Disconnect the 4-way connector of the fuel pump to be able to hear the relay and injector activation. Electrical continuity is required in the wiring for the relay to activate correctly: no errors are generated if the relay fails to activate

DIAGNOSTIC TOOL: ELECTRICAL ERRORS

Rear bank upper injector cylinder P0205

- short circuit to positive / short circuit to negative / open circuit

Error cause

- Short-circuit to positive: excessive voltage has been detected on VEHICLE PIN 53. If short circuit to negative: no voltage has been detected. If open circuit: an interruption has been detected

Troubleshooting

- Short-circuit to positive: disconnect the injector connector, set key to ON, activate the component with the diagnostic tool and check the voltage on the orange/red cable on the injector connector (if present): if there is voltage, restore the filter box cable harness. If there is no voltage, replace the sensor
- If short circuit to negative: disconnect the injector connector, set the key to ON and check if there is a ground connection on the orange/red cable: if the connection is present, restore the cable harness. If there is no connection, replace the injector
- If open circuit: check the component correct electrical characteristic: if it is not the correct one, replace the component; if it is correct, check the connector on the component and the Marelli control unit connector: if not OK, restore. If OK, check cable continuity between VEHICLE PIN 53 and component PIN - and restore the cable harness

Front bank upper injector cylinder 2 P0206

- short circuit to positive / short circuit to negative / open circuit

Error cause

- Short-circuit to positive: excessive voltage has been detected on VEHICLE PIN 67. If short circuit to negative: no voltage has been detected. If open circuit: an interruption has been detected

Troubleshooting

- Short-circuit to positive: disconnect the injector connector, set key to ON, activate the component with the diagnostic tool and check the voltage on the white/green cable on the injector connector: if there is voltage, restore the filter box cable harness. If there is no voltage, replace the sensor
- If short circuit to negative: disconnect the injector connector, set the key to ON and check if there is a ground connection on the white/green cable: if the connection is present, restore the cable harness. If there is no connection, replace the injector
- If open circuit: check the component correct electrical characteristic: if it is not the correct one, replace the component; if it is correct, check the connector on the component and the Marelli control unit connector: if not OK, restore. If OK, check cable continuity between VEHICLE PIN 67 and component PIN - and restore the cable harness

Rear bank upper injector cylinder 3 P0207

- short circuit to positive / short circuit to negative / open circuit

Error cause

- Short-circuit to positive: excessive voltage has been detected on VEHICLE PIN 74. If short circuit to negative: no voltage has been detected. If open circuit: an interruption has been detected

Troubleshooting

- Short-circuit to positive: disconnect the injector connector, set key to ON, activate the component with the diagnostic tool and check the voltage on the White/Purple cable on the injector connector: if there is voltage, restore the filter box cable harness. If there is no voltage, replace the sensor
- If short circuit to negative: disconnect the injector connector, set the key to ON and check if there is a ground connection on the white/purple cable: if the connection is present, restore the cable harness. If there is no connection, replace the injector
- If open circuit: check the component correct electrical characteristic: if it is not the correct one, replace the component; if it is correct, check the connector on the component and the Marelli control unit connector: if not OK, restore. If OK, check cable continuity between VEHICLE PIN 74 and component PIN - and restore the cable harness

Front bank upper injector cylinder 4 P0208

- short circuit to positive / short circuit to negative / open circuit

Error cause

- Short-circuit to positive: excessive voltage has been detected on VEHICLE PIN 68. If short circuit to negative: no voltage has been detected. If open circuit: an interruption has been detected

Troubleshooting

- Short-circuit to positive: disconnect the injector connector, set key to ON, activate the component with the diagnostic tool and check the voltage on the White/Blue cable on the injector connector: if there is voltage, restore the filter box cable harness. If there is no voltage, replace the sensor
- If short circuit to negative: disconnect the injector connector, set the key to ON and check if there is a ground connection on the white/blue cable: if the connection is present, restore the cable harness. If there is no connection, replace the injector
- If open circuit: check the component correct electrical characteristic: if it is not the correct one, replace the component; if it is correct, check the connector on the component and the Marelli control unit connector: if not OK, restore. If OK, check cable continuity between VEHICLE PIN 68 and component PIN - and restore the cable harness

Fuel pump

Function

Fuel pump: keeps pressure of the injectors supply duct.

Low fuel: tells to the instrument panel about low fuel

Operation / Operating principle

Low fuel: it is a resistance that if correctly supplied varies its electrical resistance if it is damped or not by petrol.

Level in electrical circuit diagram:

Injection load relay

Location:

- on the vehicle: on the tank.
- connector: on right rear frame (4-ways black).

Electrical characteristics:

PIN 1-2: 0.5 - 1 ohm; PIN 3-4: you do not need to measure the component electrical resistance since it works correctly with suitable supply from the instrument panel only. Check correct operation

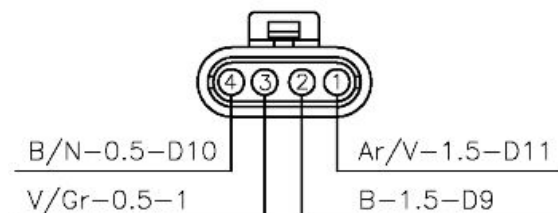

as follows: connect in series a bulb of approximately 2 W: it should turn on if the tank is in reserve, otherwise, it remains off.

Pin out:

1. + 12 V
2. ground connection
3. ground connection
4. + 12 V (signal)

CAUTION

BEFORE CARRYING OUT ANY TROUBLESHOOTING, CAREFULLY READ THE GENERAL TROUBLESHOOTING CONCEPTS FOR ELECTRICAL DEVICES AT THE BEGINNING OF THE CHECK AND CONTROL SECTION IN THE ELECTRICAL SYSTEM CHAPTER.

DIAGNOSIS INSTRUMENT: ACTIVATION

Fuel pump

NOTE: The injection relay (No 33 in the wiring diagram, position under the saddle, next to the battery positive, CHECK, however, the identification of the relay with the colour of the cables) is energised for 30 seconds. The continuity of the wiring is necessary for correct activation: no error indications are displayed in case of lack of activation

DIAGNOSIS INSTRUMENT: ELECTRICAL ERRORS

fuel pump relay control P0230

- shorted to positive / open circuit, shorted to negative.

Error cause

- If shorted to positive: excessive voltage has been detected at PIN 73 of the VEHICLE connector. If the circuit is open, shorted to negative: voltage equal to zero has been detected at PIN 73 of the VEHICLE connector.

Troubleshooting

- If shorted to positive: check whether the relay electrical specifications are correct by disconnecting it from the cable harness. If are not OK, replace the relay; if OK, restore the cable harness (Brown/Black cable).
 - If the circuit is open, shorted to negative: check the relay electrical characteristics are correct by disconnecting it from the cable harness; if it is not OK, replace the relay, if it is OK, check relay connector, engine-vehicle cable harness connector and VEHICLE connector of the Marelli control unit: if not OK, restore; if OK, check continuity of cable harness (Brown/Black cable)
-

Coil

Function

Spark generation

Operation / Operating principle

With inductive discharge

Level in electrical circuit diagram:

coils and injectors

Position:

- on the vehicle: on the big end covers.
- connector: For each coil 3 way black connector. coil 1 with short cable: to the left, on the rear side of the filter housing; coil 2 with long cable: to the left of the front part of the filter housing (connector with red strip on the engine wiring harness), coil 3 with long cable: to the left, on the rear side of the filter housing (connector with red strip on the engine wiring harness); coil 4 with short cable: to the right of the front part of the filter housing.

Electrical specifications:

0.7- 0.9 Ω at ambient temperature

Pin out:

1. Power supply +Vbatt
2. Secondary circuit ground
3. Activation from the control unit

DIAGNOSTIC TOOL:PARAMETERS

Example value with key ON:Actual start-up advance

Example value with engine on: Indicates the advance of the cylinder in which the combustion will take place.

CAUTION

BEFORE CARRYING OUT ANY TROUBLESHOOTING, CAREFULLY READ THE GENERAL TROUBLESHOOTING CONCEPTS FOR ELECTRICAL DEVICES AT THE BEGINNING OF THE CHECK AND CONTROL SECTION IN THE ELECTRICAL SYSTEM CHAPTER.

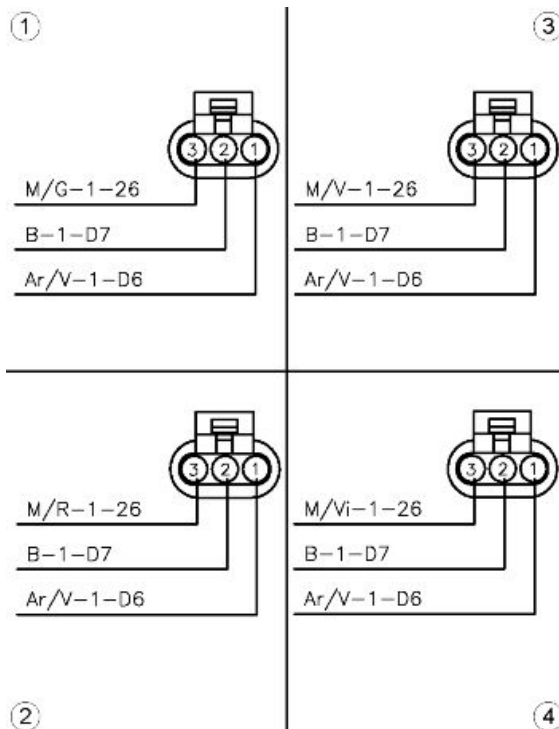

DIAGNOSTIC TOOL: ACTIVATIONS**Coil 1:**

The injection relay (no. 33 in the electrical circuit diagram, placed under the saddle next to the battery positive, CHECK, however, the identification of the relay with the colour of the cables) is energised for 5 seconds and the Brown/Yellow cable of the coil is closed to ground for 2 ms per each second. Disconnect the 4-way connector of the fuel pump to be able to hear the relay and injector activation.

Electrical continuity is required in the wiring for the relay to activate correctly: no errors are generated in case of no activation.

Coil 2:

The injection relay (no. 33 in the electrical circuit diagram, placed under the saddle next to the battery positive, CHECK, however, the identification of the relay with the colour of the cables) is energised for 5 seconds and the Brown/Red cable of the coil is closed to ground for 2 ms per each second. Disconnect the 4-way connector of the fuel pump to be able to hear the relay and injector activation. Electrical

continuity is required in the wiring for the relay to activate correctly: no errors are generated in case of no activation.

Coil 3:

The injection relay (no. 33 in the electrical circuit diagram, placed under the saddle next to the battery positive, CHECK, however, the identification of the relay with the colour of the cables) is energised for 5 seconds and the Brown/Green cable of the coil is closed to ground for 2 ms per each second. Disconnect the 4-way connector of the fuel pump to be able to hear the relay and injector activation.

Electrical continuity is required in the wiring for the relay to activate correctly: no errors are generated in case of no activation.

Coil 4:

The injection relay (no. 33 in the electrical circuit diagram, placed under the saddle next to the battery positive, CHECK, however, the identification of the relay with the colour of the cables) is energised for 5 seconds and the Brown/Violet cable of the coil is closed to ground for 2 ms per each second. Disconnect the 4-way connector of the fuel pump to be able to hear the relay and injector activation.

Electrical continuity is required in the wiring for the relay to activate correctly: no errors are generated in case of no activation.

DIAGNOSTIC TOOL: ELECTRICAL ERRORS**P0351 Coil 1****Electrical diagnosis:**

- Short circuit to positive / short circuit to negative, open circuit.

Error cause:

- Short-circuit to positive: an excessive voltage was detected at PIN 28 of the ENGINE connector. If open circuit, short circuit to negative: a voltage equal to zero was detected at PIN 28 of the ENGINE connector.

Troubleshooting:

- Short-circuit to positive: disconnect the coil connector, turn the key to ON, activate the coil with the diagnostic tool and check the voltage at PIN 28 of the connector: if there is voltage, restore the wiring harness, if the voltage is 0, replace the coil.
- If open circuit, short circuit to negative: check the electrical characteristics of the coil: if not ok, replace the coil; if ok, perform the check procedure for the coil connector and for the Marelli control unit connector; if not ok restore; if everything is ok, check the continuity of the cable between the two ends of the cable: if there is no continuity, restore the wiring harness; if there is continuity, with key ON, check the cable ground insulation (from the coil connector or control unit connector); if not ok, restore the wiring harness.

P0352 Coil 2**Electrical diagnosis:**

- Short circuit to positive / short circuit to negative, open circuit.

Error cause:

- Short-circuit to positive: an excessive voltage was detected at PIN 27 of the ENGINE connector. If open circuit, short circuit to negative: a voltage equal to zero was detected at PIN 27 of the ENGINE connector.

Troubleshooting:

- Short-circuit to positive: disconnect the coil connector, turn the key to ON, activate the coil with the diagnostic tool and check the voltage at PIN 27 of the connector: if there is voltage, restore the wiring harness, if the voltage is 0, replace the coil.
- If open circuit, short circuit to negative: check the electrical characteristics of the coil: if not ok, replace the coil; if ok, perform the check procedure for the coil connector and for the Marelli control unit connector; if not ok restore; if everything is ok, check the continuity of the cable between the two ends of the cable: if there is no continuity, restore the wiring harness; if there is continuity, with key ON, check the cable ground insulation (from the coil connector or control unit connector); if not ok, restore the wiring harness.

P0353 Coil 3**Electrical diagnosis:**

- Short circuit to positive / short circuit to negative, open circuit.

Error cause

- Short-circuit to positive: an excessive voltage was detected at PIN 2 of the ENGINE connector. If open circuit, short circuit to negative: a voltage equal to zero was detected at PIN 2 of the ENGINE connector.

Troubleshooting

- Short-circuit to positive: disconnect the coil connector, turn the key to ON, activate the coil with the diagnostic tool and check the voltage at PIN 2 of the connector: if there is voltage, restore the wiring harness, if the voltage is 0, replace the coil.
- If open circuit, short circuit to negative: check the electrical characteristics of the coil: if not ok, replace the coil; if ok, perform the check procedure for the coil connector and for the Marelli control unit connector; if not ok restore; if everything is ok, check the continuity of the cable between the two ends of the cable: if there is no continuity, restore the wiring harness; if there is continuity, with key ON, check the cable ground insulation (from the coil connector or control unit connector); if not ok, restore the wiring harness.

P0354 Coil 4

Electrical diagnosis:

- Short circuit to positive / short circuit to negative, open circuit.

Error cause:

- Short-circuit to positive: an excessive voltage was detected at PIN 1 of the ENGINE connector. If open circuit, short circuit to negative: a voltage equal to zero was detected at PIN 1 of the ENGINE connector.

Troubleshooting:

- Short-circuit to positive: disconnect the coil connector, turn the key to ON, activate the coil with the diagnostic tool and check the voltage at PIN 1 of the connector: if there is voltage, restore the wiring harness, if the voltage is 0, replace the coil.
- If open circuit, short circuit to negative: check the electrical characteristics of the coil: if not ok, replace the coil; if ok, perform the check procedure for the coil connector and for the Marelli control unit connector; if not ok restore; if everything is ok, check the continuity of the cable between the two ends of the cable: if there is no continuity, restore the wiring harness; if there is continuity, with key ON, check the cable ground insulation (from the coil connector or control unit connector); if not ok, restore the wiring harness.

Throttle body

Function

Sends to the injection control unit the throttle position and activates the throttle according to the control unit

Operation / Operating principle

All the unit internal components (potentiometer and electric motor) are contactless; therefore, no electrical diagnosis is possible for the throttle body, but for the circuits connected to it only.

Level in electrical circuit diagram:

Throttle check and handle grip sensor (Demand)

Position:

- on the vehicle: inside the filter box
- connector: on the throttle body, in lower position, near the throttle motors

Pin out:

1. potentiometer signal 1
2. supply voltage + 5V
3. throttle valve control command (+)
4. potentiometer signal 2
5. throttle valve control command (-)
6. ground lead

DIAGNOSTIC TOOL:PARAMETERS**Front cylinder throttle correction**

- Example value with key ON: 0,0°
- Example value with engine on: 0.4°

The system, reading the intake pressure, tries to balance the intake pressures between the cylinders of the rear bank (1-3) and of the front bank (2-4) working on the throttle position: an acceptable value should be between -0.5 and + 0.5

Rear cylinder throttle correction

- Example value with key ON: 0,0°
- Example value with engine on: -0.2°

The system, reading the intake pressure, tries to balance the intake pressures between the cylinders of the rear bank (1-3) and of the front bank (2-4) working on the throttle position: an acceptable value should be between -0.5 and + 0.5

Front throttle Potentiometer 1 (degrees)

- Example value with key ON: 7.8°
- Example value with engine on: 1.4°

With key set to ON, the throttle is kept in position by the springs (around 5 -7°). After the engine starts up at idle, the throttle is kept close to the mechanical minimum (above or equal to 0.5°). When the gear is not engaged, at approx. 6000 rpm, throttles open very little because the requested torque is too low (around 5-7°)

Rear throttle Potentiometer 1 (degrees)

- Example value with key ON: 8°
- Example value with engine on: 1.5°

With key set to ON, the throttle is kept in position by the springs (around 5 -7°). After the engine starts up at idle, the throttle is kept close to the mechanical minimum (above or equal to 0.5°). When the gear is not engaged, at approx. 6000 rpm, throttles open very little because the requested torque is too low (around 5-7°)

Front throttle Potentiometer 1 (voltage)

- Example value with key ON: 873 mV
- Example value with engine on: 561 mV

Rear throttle Potentiometer 1 (voltage)

- Example value with key ON: 883 mV
- Example value with engine on: 536 mV

Front throttle Potentiometer 2 (voltage)

- Example value with key ON: 4123 mV
- Example value with engine on: 4426 mV

Rear throttle Potentiometer 2 (voltage)

- Example value with key ON: 4113 mV
- Example value with engine on: 4455 mV

Front throttle Potentiometer 2 (degrees)

- Example value with key ON: 8.0°
- Example value with engine on: 1.5°

With key set to ON, the throttle is kept in position by the springs (around 5 -7°). After the engine starts up at idle, the throttle is kept close to the mechanical minimum (above or equal to 0.5°). When the gear is not engaged, at approx. 6000 rpm, throttles open very little because the requested torque is too low (around 5-7°)

Rear throttle Potentiometer 2 (degrees)

- Example value with key ON: 8.2°
- Example value with engine on: 1.6°

With key set to ON, the throttle is kept in position by the springs (around 5 -7°). After the engine starts up at idle, the throttle is kept close to the mechanical minimum (above or equal to 0.5°). When the gear is not engaged, at approx. 6000 rpm, throttles open very little because the requested torque is too low (around 5-7°)

Front cylinders throttle Limp Home position

- Example value with key ON: 878 mV

Voltage stored in the control unit corresponding to the Limp home position

Rear cylinders throttle Limp Home position

- Example value with key ON: 888 mV

Voltage stored in the control unit corresponding to the Limp home position

Front throttle lower position

- Example value with key ON: 502 mV

Voltage stored in the control unit corresponding to the throttle mechanical minimum position

Rear throttle lower position

- Example value with key ON: 492 mV

Voltage stored in the control unit corresponding to the throttle mechanical minimum position

CAUTION

BEFORE CARRYING OUT ANY TROUBLESHOOTING, CAREFULLY READ THE GENERAL TROUBLESHOOTING CONCEPTS FOR ELECTRICAL DEVICES AT THE BEGINNING OF THE CHECK AND CONTROL SECTION IN THE ELECTRICAL SYSTEM CHAPTER.

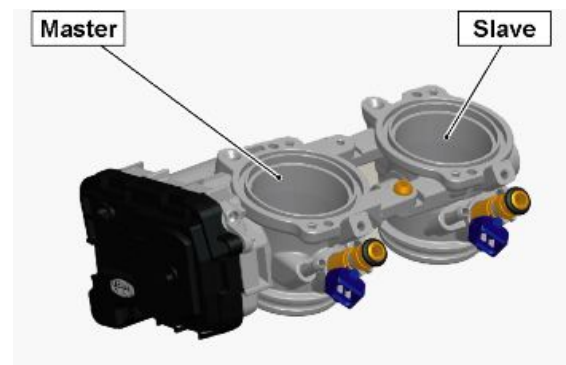
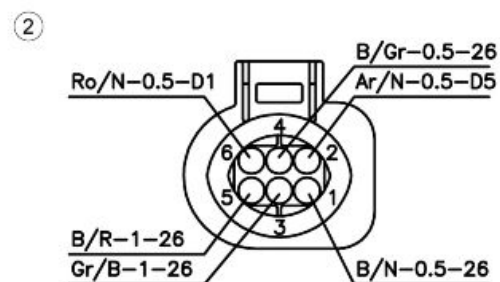
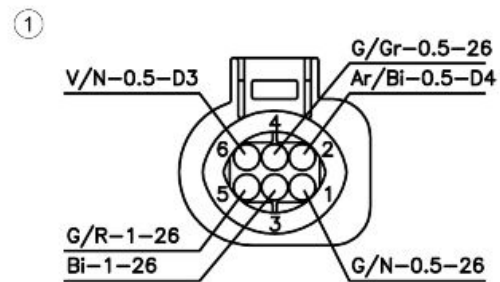
**DIAGNOSTIC TOOL: STATUSES****Front throttle automatic self-learning**

- Ice/Interrupted/Performed/Limp home/Throttle valve stopper closed/Spring check/Limp home acquisition/Initialization

Indicates if the self-learning performed by the control unit was performed/not performed: this is fundamental for understanding if the acquisition was successful at the last key ON

Rear throttle automatic self-learning

- Ice/Interrupted/Performed/Limp home/Throttle valve stopper closed/Spring check/Limp home acquisition/Initialization

Indicates if the self-learning performed by the control unit was performed/not performed: this is fundamental for understanding if the acquisition was successful at the last key ON

Throttle self-learning with diagnostics instrument

- Performed/Not performed

Indicates if the self-learning with the diagnostic tool was performed/not performed: if it was performed one time, it will always remain performed unless a control unit EEPROM reset is carried out

DIAGNOSTIC TOOL: ELECTRICAL ERRORS

CAUTION

IF ERRORS ARE DETECTED ON BOTH THROTTLE BODIES, CHECK ALSO THE CORRECT SUPPLY OF THE CONTROL UNIT TO PIN 42.

Rear bank throttle valve position potentiometer sensor P0120

- short circuit to positive / open circuit, short circuit to negative

Error cause

- Short-circuit to positive: excessive voltage has been detected on PIN 48. If open circuit, short circuit to negative: voltage equal to zero detected at PIN 48

Troubleshooting

- Short-circuit to positive: check the value shown by the parameter of the Rear throttle Potentiometer 1 (voltage): disconnect the connector and read the value indicated in the diagnostic tool: if the voltage does not vary, there is a short circuit of the cable, if the voltage goes to zero, replace the throttle body
- If open circuit, short circuit to negative: check the throttle body connector and the control unit connector, if not ok restore, if everything is ok check the continuity of the circuit between the two terminals, if not ok restore the wiring harness, if ok check the ground insulation of the circuit (from the throttle valve sensor connector or control unit connector), if ground insulated, check that the power supply (+5 V) is present at PIN 2 of the throttle body connector and that ground is present at PIN 6, if present correctly replace the throttle body

Rear bank throttle valve position potentiometer sensor CF2 P2120

- short circuit to positive / open circuit, short circuit to negative

Error cause

- Short-circuit to positive: excessive voltage has been detected on PIN 50. If open circuit, short circuit to negative: voltage equal to zero detected at PIN 50

Troubleshooting

- Short-circuit to positive: check the value shown by the parameter of the Front throttle Potentiometer 2 (voltage): disconnect the connector and read the value indicated in the diagnostic tool: if the voltage does not vary, there is a short circuit of the cable, if the voltage goes to zero, replace the throttle body
- If open circuit, short circuit to negative: check the throttle body connector and the control unit connector, if not ok restore, if everything is ok check the continuity of the circuit between the two terminals, if not ok restore the wiring harness, if ok check the ground insulation of the circuit (from the throttle valve sensor connector or control unit connector), if ground

insulated, check that the power supply (+5 V) is present at PIN 2 of the throttle body connector and that ground is present at PIN 6, if present correctly replace the throttle body

Front bank throttle valve position potentiometer sensor P0220

- short circuit to positive / open circuit, short circuit to negative

Error cause

- Short-circuit to positive: excessive voltage has been detected on PIN 36. If open circuit, short circuit to negative: voltage equal to zero detected at PIN 36

Troubleshooting

- Short-circuit to positive: check the value shown by the parameter of the Rear throttle Potentiometer 1 (voltage): disconnect the left side connector and read the value indicated in the diagnostic tool: if the voltage does not vary, there is a short circuit in the cable wiring; replace the throttle body if the voltage drops to zero
- If open circuit, short circuit to negative: check the throttle body connector and the control unit connector, if not ok restore, if everything is ok check the continuity of the circuit between the two terminals, if not ok restore the wiring harness, if ok check the ground insulation of the circuit (from the throttle valve sensor connector or control unit connector), if ground insulated, check that the power supply (+5 V) is present at PIN 2 of the throttle body connector and that ground is present at PIN 6, if present correctly replace the throttle body

Front throttle valve position potentiometer sensor CF2 P2125

- short circuit to positive / open circuit, short circuit to negative

Error cause

- Short-circuit to positive: excessive voltage has been detected on PIN 21. If open circuit, short circuit to negative: voltage equal to zero detected at PIN 21

Troubleshooting

- Short-circuit to positive: check the value shown by the parameter of the rear Throttle Potentiometer 2 (voltage): disconnect the left side connector and read the value indicated in the diagnostic tool: if the voltage does not vary, there is a short circuit in the cable wiring; replace the throttle body if the voltage drops to zero
- If open circuit, short circuit to negative: check the throttle body connector and the control unit connector, if not ok restore, if everything is ok check the continuity of the circuit between the two terminals, if not ok restore the wiring harness, if ok check the ground insulation of the circuit (from the throttle valve sensor connector or control unit connector), if ground insulated, check that the power supply (+5 V) is present at PIN 2 of the throttle body connector and that ground is present at PIN 6, if present correctly replace the throttle body

Rear throttle control circuit P2119

- short circuit to positive / short circuit to negative / open circuit, overcurrent, excessive internal temperature

Error cause

- Short-circuit to positive: excessive voltage detected on PIN 29 or 41 of the 7SM control unit. If short circuit to negative: no voltage has been detected. If open circuit: an interruption or excessive absorption of amperes or overheating of the control unit was detected

Troubleshooting

- Short-circuit to positive: disconnect the throttle body connector, turn the key OK and check the voltage at PIN 3: if a voltage greater than or equal to 5 V is read, there is a short circuit of the relative cable, if the voltage is zero, replace the throttle body
- If short circuit to negative: disconnect the throttle body connector, turn the key ON and check if PIN 3 has continuity with the vehicle ground: if there is continuity restore the wiring harness, if there is no continuity replace the throttle body
- If there is open circuit, overcurrent, excessive internal temperature: check the throttle body connector and the control unit connector: if not ok restore, if everything is ok disconnect the connector of the throttle body and the control unit connector and check cable continuity; if there is no continuity, restore the cable harness. If there is continuity, with the throttle body connector connected, check that the resistance, from the throttle control unit connector, between PIN 29 and 41 is within 1 and 2.5 Ohm; if not ok replace the throttle body, if ok check that the throttle body is not mechanically blocked: if blocked, remove the cause or replace the body, if not blocked replace the control unit

Front throttle valve control circuit P1119

- short circuit to positive / short circuit to negative / open circuit, overvoltage, excessive internal temperature circuit open

Error cause

- Short-circuit to positive: excessive voltage detected on PIN 3 or 15 of the 7SM control unit. If short circuit to negative: no voltage has been detected. If open circuit: an interruption or excessive absorption of amperes or overheating of the control unit was detected

Troubleshooting

- Short-circuit to positive: disconnect the throttle body connector, turn the key OK and check the voltage at PIN 3: if a voltage greater than or equal to 5 V is read, there is a short circuit of the relative cable, if the voltage is zero, replace the throttle body
- If short circuit to negative: disconnect the throttle body connector, turn the key ON and check if PIN 3 has continuity with the vehicle ground: if there is continuity restore the wiring harness, if there is no continuity replace the throttle body
- If there is open circuit, overcurrent, excessive internal temperature: check the throttle body connector and the control unit connector: if not ok restore, if everything is ok disconnect the

connector of the throttle body and the control unit connector and check cable continuity; if there is no continuity, restore the cable harness. If there is continuity, with the throttle body connector connected, check that the resistance, from the throttle control unit connector, between PIN 3 and 15 is within 1 and 2.5 Ohm; if not ok replace the throttle body, if ok check that the throttle body is not mechanically blocked: if blocked, remove the cause or replace the body, if not blocked replace the control unit

DIAGNOSTIC TOOL: LOGIC ERRORS

Rear bank throttle valve position potentiometer sensor P0121

- Signal not plausible

Error cause

- Signal outside the specified value determined based on the values of the intake pressure

Troubleshooting

- Check the parameter of the Potentiometer 1 front Throttle (voltage) to get which signal the control unit receives and to compare it to the Potentiometer 1 rear Throttle (voltage). Check the throttle body connector and the control unit connector. Check that cable resistance between the throttle body connector (PIN 1) and the control unit (PIN48) is a few tenths of an Ohm. Otherwise, restore the wiring harness if ok replace the complete throttle body

Rear throttle valve potentiometer CF2 P2121

- Signal not plausible

Error cause

- Signal outside the specified value determined based on the values of the intake pressure

Troubleshooting

- Check the parameter of the Potentiometer 2 front Throttle (voltage) to get which signal the control unit receives and to compare it to the Potentiometer 2 rear Throttle (voltage). Check the throttle body connector and the control unit connector. Check that the resistance of the cable between the throttle body connector (PIN 4) and the control unit (PIN 50) is a few tenths of ohm. Otherwise, restore the wiring harness if ok replace the complete throttle body

Throttle valve position potentiometers P2135

- Signal not congruent

Error cause

- Potentiometer 1 and potentiometer 2 do not provide a congruent value: the sum of the two voltages must be constant. The cause could be the malfunction of one of the two sensors or an abnormal resistance in one of the two circuits

Troubleshooting

- Check the throttle body connector and the control unit connector. Check that the resistance of the cable between the throttle body connector (PIN 1) and the control unit (PIN 48) is a few tenths of ohm. Check that the resistance of the cable between the throttle body connector (PIN 4) and the control unit (PIN 50) is a few tenths of ohm. If one of the two is different, restore the wiring harness if ok replace the complete throttle body

Front bank throttle valve position potentiometer sensor P0221

- Signal not plausible

Error cause

- Signal outside the specified value determined based on the values of the intake pressure

Troubleshooting

- Check the parameter of the Potentiometer 1 rear throttle (voltage) to get which signal the control unit receives and to compare it to the Potentiometer 1 front throttle (voltage). Check the throttle body connector and the control unit connector. Check that the resistance of the cable between the throttle body connector (PIN 1) and the control unit (PIN 36) is a few tenths of an ohm. Otherwise, restore the wiring harness if ok replace the complete throttle body

Front throttle valve potentiometer CF2 P2126

- Signal not plausible

Error cause

- Signal outside the specified value determined based on the values of the intake pressure

Troubleshooting

- Check the parameter of the Potentiometer 2 rear throttle (voltage) to get which signal the control unit receives and to compare it to the Potentiometer 2 front throttle (voltage). Check the throttle body connector and the control unit connector. Check that cable resistance between the throttle body connector (PIN 4) and the throttle control unit (PIN 21) is a few tenths of an Ohm. Otherwise, restore the wiring harness if ok replace the complete throttle body

Throttle valve position sensors CF2 P2138

- Signal not congruent

Error cause

- Potentiometer 1 and potentiometer 2 do not provide a congruent value: the sum of the two voltages must be constant. The cause could be the malfunction of one of the two sensors or an abnormal resistance in one of the two circuits

Troubleshooting

- Check the throttle body connector and the control unit connector. Check that the resistance of the cable between the throttle body connector (PIN 1) and the control unit (PIN 36) is a few tenths of an ohm. Check that cable resistance between the throttle body connector (PIN

4) and the throttle control unit (PIN 21) is a few tenths of an Ohm. If one of the two is different, restore the wiring harness if ok replace the complete throttle body

Rear throttle valve Limp Home self-acquisition P1400

- Test failed

Error cause

- Position of the throttle valve, maintained by the springs, outside the specified range (at each key ON). The instrument panel does not indicate the presence of this error even in the ATT status

Troubleshooting

- Check the cleanliness of the throttle body and the intake duct. If ok replace the throttle body

Rear throttle valve mechanical (re-closing) springs self-learning P1405

- Test failed

Error cause

- Throttle valve return time, in the position maintained by the springs, outside of the specified limits: the causes can be a deterioration of spring performance or excessive throttle valve friction (at each key ON)

Troubleshooting

- Check the cleanliness of the throttle body and the intake duct. If ok replace the throttle body

Rear throttle valve minimum mechanical position self-learning P1402

- Test failed

Error cause

- Position of the throttle valve stopper outside of the specified range (at each key ON)

Troubleshooting

- Check the cleanliness of the throttle body and the intake duct. If ok replace the throttle body

Rear throttle valve recovery conditions detection (Tair, Twater) P1403

- Ice possibly present

Error cause

- in conditions of low ambient temperature and engine temperature, a correct throttle valve rotation was not detected: possible presence of ice in the duct (at each key ON). The instrument panel does not indicate the presence of this error even in the ATT status

Troubleshooting

- Check the cleanliness of the throttle body and that there is no ice or condensate in the intake duct. If ok replace the throttle body

Rear throttle valve power supply voltage during self-learning P1404

- Low power supply voltage

Error cause

- The throttle valve power supply voltage is too low to correctly perform the self-learning test (at each key ON). The instrument panel does not indicate the presence of this error even in the ATT status

Troubleshooting

- Remove the presence of errors that prevent throttle self-learning.

Rear throttle valve position error P0638

- Misalignment between control and activation

Error cause

- The throttle valve mechanical control could be damaged

Troubleshooting

- Replace the throttle body

Front throttle valve Limp Home self-learning P1406

- Test failed

Error cause

- Position of the throttle valve, maintained by the springs, outside the specified range (at each key ON). The instrument panel does not indicate the presence of this error even in the ATT status

Troubleshooting

- Check the cleanliness of the throttle body and the intake duct. If ok replace the throttle body

Front throttle valve mechanical (re-closing) springs self-learning P1411

- Test failed

Error cause

- Throttle valve return time, in the position maintained by the springs, outside of the specified limits: the causes can be a deterioration of spring performance or excessive throttle valve friction (at each key ON)

Troubleshooting

- Check the cleanliness of the throttle body and the intake duct. If ok replace the throttle body

Front throttle valve minimum mechanical position self-learning P1408

- Test failed

Error cause

- Position of the throttle valve stopper outside of the specified range (at each key ON)

Troubleshooting

- Check the cleanliness of the throttle body and the intake duct. If ok replace the throttle body

Front throttle valve recovery conditions detection (Tair,Twater) P1409

- Ice possibly present

Error cause

- in conditions of low ambient temperature and engine temperature, a correct throttle valve rotation was not detected: possible presence of ice in the duct (at each key ON). The instrument panel does not indicate the presence of this error even in the ATT status

Troubleshooting

- Check the cleanliness of the throttle body and that there is no ice or condensate in the intake duct. If ok replace the throttle body

Front throttle valve power supply voltage during self-learning P1410

- Low power supply voltage

Error cause

- The throttle valve power supply voltage is too low to correctly perform the self-learning test (at each key ON). The instrument panel does not indicate the presence of this error even in the ATT status

Troubleshooting

- Remove the presence of errors that prevent throttle self-learning.

Front throttle valve position error - EPOS P0639 error

- Misalignment between control and activation

Error cause

- The throttle valve mechanical control could be damaged

Troubleshooting

- Replace the throttle body

P1401 Rear throttle valve mechanical springs self-learning (opening)**Functional diagnosis:**

- Test failed

Error cause:

- The recognition of this error is enabled during the throttle self-learning procedure.
- Throttle valve return time, in the position maintained by the springs, outside of the specified limits: the causes can be a deterioration of spring performance or excessive throttle valve friction (at each key ON)

This error is indicated by lighting up in a fixed manner the MI warning light.

Troubleshooting:

- Using the diagnostic tool, erase the error, then perform the throttle self-learning procedure. If the error is displayed again, it may mean a mechanical problem at the throttle body.
- Check the cleanliness of the throttle body and the intake duct. Check if there are any mechanical ruptures. Replace the throttle body, if necessary.

P1407 Front throttle valve mechanical springs self-learning (opening)

Functional diagnosis:

- Test failed

Error cause:

- The recognition of this error is enabled during the throttle self-learning procedure.
- Throttle valve return time, in the position maintained by the springs, outside of the specified limits: the causes can be a deterioration of spring performance or excessive throttle valve friction (at each key ON)

This error is indicated by lighting up in a fixed manner the MI warning light.

Troubleshooting:

- Using the diagnostic tool, erase the error, then perform the throttle self-learning procedure. If the error is displayed again, it may mean a mechanical problem at the throttle body.
- Check the cleanliness of the throttle body and the intake duct. Check if there are any mechanical ruptures. Replace the throttle body, if necessary.

DIAGNOSTIC TOOL: ADJUSTABLE PARAMETERS

Throttle self-learning.

NOTE

AT EVERY "KEY ON", THE CONTROL UNIT PERFORMS A TEST ON THE THROTTLE VALVES TO CHECK THEIR MOBILITY, ASSESSING THE NECESSARY FORCE TO MOVE THEM AND THE POTENTIAL PRESENCE OF OBSTACLES. AT EVERY 150 "KEY ON", THE SYSTEM PERFORMS A STOPPER LEARNING FOR EACH THROTTLE BODY; IF START-UP IS ATTEMPTED DURING THIS PROCEDURE (THAT REQUIRES APPROXIMATELY 3 SECONDS), THE ENGINE WILL NOT START.

THROTTLE BODY RESET PROCEDURE

If a throttle body is replaced, or if it needs to perform automatic learning, proceed as follows:

After key ON, do not start the engine for the next 3 seconds, during which the throttle automatic learning is performed by the control unit: according to the throttle body concerned, check that the "Front throttle automatic self-learning" or the "Rear throttle automatic self-learning" status indicates: "completed". If the indication is not "completed", remove any errors that may exist on the vehicle and at the next key On check that the statuses are "completed". Where appropriate, perform the throttle self-learning from the "settings" screen and check that the "Throttle self-learning with diagnostics instrument" status indicates: "completed" and that the "Front throttle automatic self-learning" or "Rear throttle automatic self-learning" statuses indicate: "completed".

Engine oil pressure sensor

Function

Indicates the instrument panel if there is enough oil pressure (0.5 +/-0.2 bar) in the engine.

Operation / Operating principle

Switch normally closed (control unit signal to ground). The switch opens at pressure values above 0.5 ± 0.2 bar.

Level in electrical circuit diagram:

Low fuel and oil pressure

Position:

- on the vehicle: front side of the engine, next to the oil filter.
- connector: on the sensor.

Electrical specifications: -

Pin out:

1. Voltage: 5 V

CAUTION

BEFORE CARRYING OUT ANY TROUBLESHOOTING, CAREFULLY READ THE GENERAL TROUBLESHOOTING CONCEPTS FOR ELECTRICAL DEVICES AT THE BEGINNING OF THE CHECK AND CONTROL SECTION IN THE ELECTRICAL SYSTEM CHAPTER.

Dashboard

Oil sensor FAULT error B0001

Error cause

- An oil sensor fault is signalled when, with engine off, it is detected that the sensor circuit is open. The test is performed only once when the key is set to ON. There is an error when the general warning light turns on.

Troubleshooting

- Check the sensor connector and the instrument panel connector (PIN 13): if they are not OK, restore. If OK, check continuity of the purple cable between the sensor connector and the instrument panel connector PIN 13: if not OK, restore the wiring harness; if OK, replace the sensor.

Oil pressure FAULT error B0002

Error cause

- An oil sensor fault is signalled when, with engine running, it is detected that the sensor circuit is closed. There is an error when the general warning light turns on.

Troubleshooting



- Check if oil pressure is low with the specific gauge.

Neutral sensor

Function

Indicates to the control unit the position of the gearbox, from 1st gear to 6th gear, and if the gearbox is in neutral or drive.

Operation / Operating principle

The sensor is comprised of 2 circuits: one to indicate the gear engaged, whose potential difference varies depending on the engaged gear: in this way, depending on the detected electric voltage, the injection control unit detects the gear engaged, the other for the neutral indication whose voltage, in case of neutral position, must be 1.2 V.

Level in electrical circuit diagram:

Gear sensor, start-up enable

Position:

- on the vehicle: under the chain pinion, behind the pinion cover.
- connector: behind the filter housing (4 way transparent connector).

Electrical specifications:

VEHICLE connector PIN 64:

- neutral indication: closed circuit (continuity);
- gear engaged: open circuit (infinite resistance).

Gear circuit voltage:

- 1st gear: 1,6 V
- 2nd gear: 0,83 V
- 3rd gear: 4,6 V
- 4th gear: 3,9 V
- 5th gear: 3,1 V
- 6th gear: 2,4 V

Pin out:

1. White/black: ground from ECU
2. Red: + 5V from the ECU (reference voltage)
3. Pink: +5V from ECU (gears).
4. Light blue: + 12V from ECU (neutral)

CAUTION

BEFORE CARRYING OUT ANY TROUBLESHOOTING, CAREFULLY READ THE GENERAL TROUBLESHOOTING CONCEPTS FOR ELECTRICAL DEVICES AT THE BEGINNING OF THE CHECK AND CONTROL SECTION IN THE ELECTRICAL SYSTEM CHAPTER.

DIAGNOSTIC TOOL: STATUSES

Gearbox in neutral

- Yes/No

gear engaged: 0 - 1 - 2 - 3 - 4 - 5 - 6

DIAGNOSTIC TOOL: ELECTRICAL ERRORS

P0914 Gear sensor

Electrical diagnosis:

- short circuit to positive or open circuit / short circuit to negative / signal not plausible.

Error cause

- If open circuit, short circuit to positive: excessive voltage has been detected on PIN 72.
- If short circuit to negative: voltage equal to zero detected at PIN 72.

Troubleshooting

- If open circuit, short circuit to positive: the error is detected only when the engine is on and the vehicle is moving (gear engaged). check the sensor connector and the VEHICLE connector of the control unit: if not ok, restore; if ok, check the continuity of the Grey/Black cable between the two connectors: if not ok restore, if ok, with key ON (with the control unit connector disconnected), check from the control unit connector side if the cable is energised: if energised, disconnect the sensor connector and check if the cable is energised: if energised, restore the wiring harness; if not energised, replace the sensor (there is an interruption or a short circuit to positive of the Pink cable on the segment that goes from the sensor connector to the sensor or inside the sensor).
- If short circuit to negative: disconnect the sensor connector and, with key ON, check the voltage of the Grey/Black cable: if it is zero, restore the wiring harness; if it approximately 5 V, replace the sensor (there is short circuit to ground of the Pink cable on the segment that goes from the sensor connector to the sensor or inside the sensor).

CAUTION

IF THE ERROR IS SHOWN, IT MAY BE A FALSE CONTACT, SINCE IF THE PROBLEM PERSISTS, IT SHOULDN'T BE POSSIBLE TO START TH VEHICLE.

Clutch lever sensor

Function

Indicates the clutch lever position to the control unit.

Operation / Operating principle

If a gear is engaged but the clutch is engaged, that is circuit closed to ground, there is consent to start the vehicle.

Level in electrical circuit diagram:

Start enable switches



Position:

- on the vehicle: on the handlebar.
- connector: on the sensor.

Electrical specifications:

- Clutch engaged: closed circuit (continuity)
- Clutch released: open circuit (infinite resistance).

Pin out:

1. voltage 5V
2. ground lead

CAUTION

BEFORE CARRYING OUT ANY TROUBLESHOOTING, CAREFULLY READ THE GENERAL TROUBLESHOOTING CONCEPTS FOR ELECTRICAL DEVICES AT THE BEGINNING OF THE CHECK AND CONTROL SECTION IN THE ELECTRICAL SYSTEM CHAPTER.

DIAGNOSTIC TOOL: STATUSES

Clutch

- Intermediate_Released_Pulled

ATTENTION The statuses that can be normally shown are Released and Engaged.

- Indication on the diagnostic tool always Released: perform the check procedure for the sensor connector, for the engine-vehicle wiring harness connector (paying attention to PIN C3) and for the control unit connector (paying attention to PIN 56): if not ok, restore the wiring harness; if ok, disconnect the two ends from the sensor and, with key ON, check if there is continuity to ground at PIN 2: if there is no continuity, restore cable harness; if there is, replace the sensor.
- Indication on the diagnostic tool always Engaged: disconnect the two ends from the sensor and check if, with the clutch released, the sensor shows continuity between the two PINS: if there is continuity, replace the sensor, if there is open circuit, it means that there is a short circuit to ground of the black cable that goes from PIN 1 of the sensor to PIN C3 of the engine-vehicle cable harness connector or of the White/Violet cable that goes from PIN C3 to PIN 56 of the VEHICLE connector: restore the wiring harness.

DIAGNOSTIC TOOL: LOGIC ERRORS**P0704 Clutch switches plausibility error****Diagnosis:**

- signal not plausible.

Error cause:

- If there is one contact: the plausibility diagnosis cannot occur only at key ON but during operation. The control unit logic requires that the released/engaged and engaged/released switching time does not exceed a certain threshold. If the operating time is too long, the error is shown. To check the origin of the problem, it is enough to connect the diagnostic tool to see if, despite the clutch lever operations, the status remains "ENGAGED". Check the wiring harness or the sensor.
- If there are two contacts: the plausibility diagnosis can occur at key ON. Since there are two contacts that cannot be both "CLOSED" or both "OPEN" (excepting fraction of a second while switching from "RELEASED" to "ENGAGED" and vice versa), if they are, the error is shown.

This error is indicated by lighting up in a fixed manner the general warning light.

Troubleshooting:

- If the error is active only with the lever released: the problem is generated by the released clutch contact of the which is interrupted or by the engaged clutch contact which is in short circuit to ground.
- If the error is active only with the lever engaged: the problem is generated by the engaged clutch contact of the which is interrupted or by the released clutch contact which is in short circuit to ground.
- If the error is always active: both contacts are open or in short circuit to ground.

Depending on the case, check the concerned parts of the wiring harness and the sensor.

NOTE

THIS ERROR DISABLES THE CRUISE CONTROL.

Side stand sensor

Function

indicates to the control unit the position of the side stand

Operation / Operating principle

If the gear is engaged and the side stand is unfolded, and therefore the circuit is open, the control unit does not enable vehicle start-up or shuts off the engine if it is rotating

Level in electrical circuit diagram:

Start enable switches

Position:

- on the vehicle: on the stand



- connector: between the big end cover and the left side filter housing (2 way white connector)

Pin out:

1. Ground
2. 12 V voltage

Electrical specifications:

- Side Stand Up: closed circuit (continuity)
- Side Stand Down: open circuit (infinite resistance)

CAUTION

BEFORE CARRYING OUT ANY TROUBLESHOOTING, CAREFULLY READ THE GENERAL TROUBLESHOOTING CONCEPTS FOR ELECTRICAL DEVICES AT THE BEGINNING OF THE CHECK AND CONTROL SECTION IN THE ELECTRICAL SYSTEM CHAPTER.

DIAGNOSTIC TOOL: LOGIC ERRORS**P1850 Side stand diagnosis****Side stand functional diagnosis:**

up/down

Troubleshooting:

- Indication on the diagnostic tool always down: perform the connector check procedure: if not ok, restore; if ok, disconnect the two ends from the sensor and check the PIN 1 continuity to ground: if there is no continuity, restore cable harness; if there is, replace the sensor
 - Indication on the diagnostic tool always up: disconnect the two ends from the sensor and check if, with the stand down, there is continuity between the two PINS: if there is continuity replace the sensor; if open circuit, it means that there is short circuit to ground of the brown/green cable that goes from PIN 2 of the sensor to PIN 70 of the VEHICLE connector: restore the wiring harness
-

Electric fan circuit

Function

Activates coolant radiator fan

Operation / Operating principle

When the ECU detects a temperature of approximately 101°C, it closes the connection between the fan control relay excitation circuit and ground

Level in electrical circuit diagram:

electric fan

Position:

- sensor: relay located in the front recess of the chassis, to the right
- connector: on relay

Electrical specifications:

- relay normally open;
- drive coil resistance 110 Ohm (+/- 10 %)

DIAGNOSTIC TOOL:STATUSES

Fan relay

- on/off

DIAGNOSTIC TOOL:ACTIVATIONS

Fan

- Energy is applied for 10 seconds to the fan relay (36 in the electrical circuit diagram, position in the steering headstock recess, to the right; however, CHECK the identification of the relay with the colour of the cables). Electrical continuity is required in the wiring for the relay to activate correctly: no errors are generated if the relay fails to activate

CAUTION

BEFORE CARRYING OUT ANY TROUBLESHOOTING, CAREFULLY READ THE GENERAL TROUBLESHOOTING CONCEPTS FOR ELECTRICAL DEVICES AT THE BEGINNING OF THE CHECK AND CONTROL SECTION IN THE ELECTRICAL SYSTEM CHAPTER.

DIAGNOSTIC TOOL: ELECTRICAL ERRORS

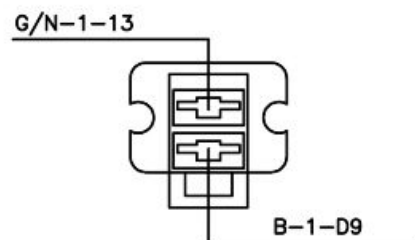
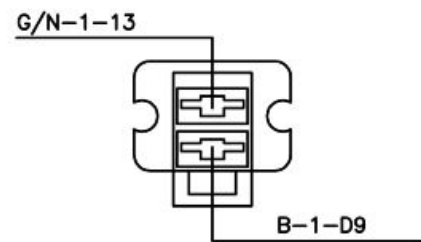

P0480 Cooling fan command**Electrical diagnosis:**

- short circuit to positive/ short circuit to negative / open circuit

Error cause:

- Short-circuit to positive: excessive voltage has been detected at PIN 61 of the VEHICLE connector.
- If short circuit to negative: no voltage has been detected.
- If open circuit: 5V voltage has been detected. Error recognition carries out only when the fan relay is activated.

Troubleshooting:

- Short-circuit to positive: check the relay electrical specifications are correct by disconnecting it from the cable harness. If not OK, replace the relay; if OK, restore the cable harness (Brown cable)
- If short circuit to negative: check the relay electrical specifications are correct by disconnecting it from the cable harness. If not OK, replace the relay; if OK, restore the cable harness (Brown cable)
- If open circuit: check the relay electrical characteristics are correct by disconnecting it from the cable harness; if it is not OK, replace the relay, if it is OK, check relay connector, engine-vehicle cable harness connector and VEHICLE connector of the Marelli control unit: if not OK, restore; if OK, check continuity of cable harness (Brown cable)

SAS valve actuator**Function**

Quickly warms up the catalytic converter and keeps the combustion rich in some critical conditions

Operation / Operating principle

The valve coil is excited to open the air passage of the filter box to the exhaust manifold

Level in electrical circuit diagram:

Secondary air system

Position:

- on the vehicle: under throttle bodies, in the V between the two front and rear cylinders banks
- connector: on the valve

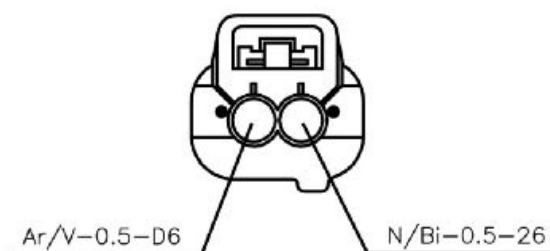

Electrical specifications:

Resistance at ambient temperature: 21 +3/- 1 Ω

Pin out:

1. Power supply V batt
2. Ground

DIAGNOSTIC TOOL:PARAMETERS**Secondary air valve duty cycle**

- Example value with key ON: 0 %
- Example value with engine on: %

Used only at 0 or 100%

CAUTION

BEFORE CARRYING OUT ANY TROUBLESHOOTING, CAREFULLY READ THE GENERAL TROUBLESHOOTING CONCEPTS FOR ELECTRICAL DEVICES AT THE BEGINNING OF THE CHECK AND CONTROL SECTION IN THE ELECTRICAL SYSTEM CHAPTER.

DIAGNOSTIC TOOL: ELECTRICAL ERRORS**P0410 Secondary air valve control****Electrical diagnosis:**

- short circuit to positive / short circuit to negative / open circuit

Error cause:

- Short-circuit to positive: Excessive voltage detected on PIN 43 of the 7SM control unit.
- If shorted to negative/open circuit: no voltage has been detected. The instrument panel indicates this error by lighting up in a fixed manner the MI warning light.

Troubleshooting:

- Short-circuit to positive: disconnect the component, set the key to ON, start the vehicle and check if the error symptom is still "shorted to positive": it means that short circuit is between black/white cable and a cable in voltage, therefore restore cable harness; if the error symptom is short circuit to ground, it means that short circuit is inside the valve and therefore, you must replace the component.
- If shorted to negative or open circuit: check the component connector and control unit connector: if not OK, restore; if OK, check the continuity of the black/white cable between the two connectors: if not OK, restore wiring harness; if OK, with key ON, check if there is voltage on PIN 1 of the actuator: if there is not voltage, check orange/green cable; if there is voltage, check component electrical characteristics and replace the component



RUN/STOP switch

Function

Indicates the control unit if the rider wishes to enable engine start-up or to keep the engine running.

Operation / Operating principle

If you want to stop the engine or to prevent it from starting, the switch must be open, meaning that PIN 78 of the VEHICLE connector of the Marelli control unit must not be grounded.



Level in electrical circuit diagram:

Start enable switches

Position:

- on the vehicle: Right hand light switch.
- connector: inside the support (4-ways black).

Electrical specifications:

- STOP position: open circuit
- RUN position: closed circuit (continuity)

Pin out:

1. Ground - Green/Pink colour
2. 5V signal - Engine start-up - Pink/Brown colour
3. Ground - Green/Pink colour
4. 5V signal - Engine stop - Pink/Yellow colour

CAUTION

BEFORE CARRYING OUT ANY TROUBLESHOOTING, CAREFULLY READ THE GENERAL TROUBLESHOOTING CONCEPTS FOR ELECTRICAL DEVICES AT THE BEGINNING OF THE CHECK AND CONTROL SECTION IN THE ELECTRICAL SYSTEM CHAPTER.

DIAGNOSTIC TOOL: STATUSES

RUN/STOP switch

- Run/Stop

NOTES

- Indication on the diagnostic tool always STOP: disconnect the connector and check with the RUN switch if there is continuity towards the two Blue/Green and Yellow/Red cables: if it is missing, replace the sensor; if there is, perform the connector check procedure: if not ok, restore the wiring harness; if ok, check with the key ON if there is voltage on the Yellow/Red cable: if it is missing, restore the wiring harness; if there is, check the ground insulation of

the Yellow/Red cable: if there is continuity with the ground, restore the wiring harness; if ok, turn the key to OFF and perform the VEHICLE connector and engine-vehicle wiring harness connector check: if not ok, restore; if ok, check the continuity of the Yellow/Pink cable between the switch connector and the VEHICLE connector PIN C7 and PIN 78: if not ok, restore the wiring harness; if ok, replace the Marelli control unit.

- Indication on the diagnostic tool always RUN: disconnect the connector and check with the switch in STOP of there is continuity between the two cables of the switch: if there is, replace the switch, if there is no continuity it means that, with the key ON, the Yellow/Pink cable (between the switch and PIN C7 of the engine-vehicle wiring harness connector or between the latter and PIN 78 of the control unit connector) is in short circuit to positive: restore the wiring harness.

Butterfly valve in exhaust

Function

Used to reduce the noise at the exhaust. The exhaust valve is controlled as follows:

- With engine off: completely closed 0%
- With engine on: depending on the gear engaged, the exhaust valve has different opening values, according to the engine speed and load. Above 6,000 rpm, the valve is always open, except for neutral.
- With the motorcycle at a standstill and with the gearbox to neutral, the valve stays closed until 7,000 rpm.

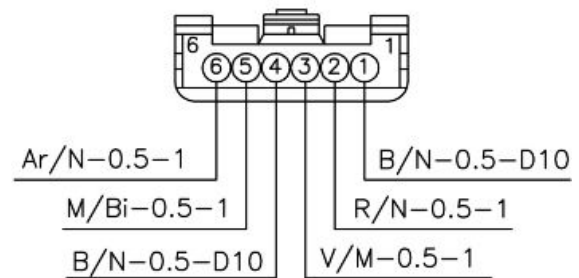

Operation / Operating principle

The system consists of a throttle valve with return spring on the exhaust. The valve is closed by 2 cables operated by an electric motor which is electrically connected to the instrument panel. The logic and the motor control, however, reside in the Marelli injection control unit that dialogues with the instrument panel via the CAN.

Level in electrical circuit diagram:

Exhaust valve

Position:

- on the vehicle: The motor is located in the front lower part of the engine. The valve in the exhaust pipe.
- connector: on the motor.

Electrical specifications:

- Electric motor resistance (PIN 4-5): 2-4 Ohm
- Potentiometer resistance (PIN 1-3): 10.1 kOhm +/- 10%

Pin out:

1. 5V supply voltage
2. Output signal (0- 5 V)
3. Ground
4. A motor power supply
5. B motor power supply

DIAGNOSTIC TOOL: PARAMETERS

Exhaust valve objective position: 0 - 100 %

NOTES: Value that the control unit sends to the instrument panel to operate the valve: 0% (valve closed), 100 % (valve open).

CAUTION

BEFORE CARRYING OUT ANY TROUBLESHOOTING, CAREFULLY READ THE GENERAL TROUBLESHOOTING CONCEPTS FOR ELECTRICAL DEVICES AT THE BEGINNING OF THE CHECK AND CONTROL SECTION IN THE ELECTRICAL SYSTEM CHAPTER.

DIAGNOSTIC TOOL: STATUSES

Exhaust valve

- Not determined/searching/activation at key ON/ in operation/ stopped due to detected faults/ zero searching.

NOTES: If there is no problem, the following is displayed: in operation.

DIAGNOSTIC TOOL: ELECTRICAL ERRORS**P1501 Exhaust valve stoppers search****Diagnosis:**

- potentiometer signal above the maximum threshold/ potentiometer signal under the minimum threshold/excessive duration/search not performed.

Error cause:

- If the potentiometer signal is above the maximum threshold: a voltage of the maximum limit stop (open valve) was detected outside the established range.
- If the potentiometer signal is under the minimum threshold: a voltage of the minimum limit stop (closed valve) was detected outside the established range.
- If excessive duration: an excessive duration for the stopper search (potential mechanical problem of the valve, of the motor or cables not connected) was detected.
- If research not performed: this symptom may be caused if a new instrument panel is fitted and the stopper self-learning has not yet been performed, if the stroke between minimum and maximum is too short or too long.

This error is indicated by lighting up in a fixed manner the general warning light.

Troubleshooting:

- If the potentiometer signal is above the maximum threshold: during the "Exhaust valve self-learning" setting, a maximum opening limit stop voltage was detected outside the established range. Check the correct voltage of the two cables of the valve.
- If the potentiometer signal is under the minimum threshold: during the "Exhaust valve self-learning" setting, a minimum opening limit stop voltage was detected outside the established range. Check the correct voltage of the two cables of the valve.
- If excessive duration: check if the valve cables are energised: if they are not energised, energise them; if ok, check if the mechanical rotation of the exhaust valve occurs without friction or delays: if not ok, restore the normal valve rotation; if ok, check the electrical characteristics of the motor: if not ok, replace the motor; if ok, perform the check procedure for the valve connector and for the instrument panel connector (with special attention to any signs of oxidation): if not ok restore; if ok, replace the electric motor. Also check the state of the cables.
- If research not performed or incorrect stroke: perform the "Exhaust valve self-learning" procedure if the stoppers learning has not yet been performed after the installation of the new instrument panel. If the instrument panel is not new, check if the calibration of the cable is correct and if it is correct, check that there is no obstacle to the valve rotation.

CAUTION

AFTER EACH MAINTENANCE OR CHECK OPERATION AT THE EXHAUST VALVE, PERFORM THE "EXHAUST VALVE CABLES CLEARANCE ADJUSTMENT" PROCEDURE.

P1502 Exhaust valve engine DC error

Electrical diagnosis:

- open circuit, thermal protection, short circuit to negative, short circuit to positive or short circuit between the two cables.

Error cause:

- If open circuit: a too low current consumption was detected at PIN1/PIN10 of the instrument panel connector.
- If thermal protection: anomaly at the instrument panel.
- If short circuit to negative: voltage equal to zero has been detected.
- If short circuit to positive or short circuit between the two cables: excessive voltage has been detected.

This error is indicated by flashing the general warning light and by lighting up in a fixed manner the MI warning light.

Troubleshooting:

- If open circuit: may be due to loose cables, in which case make sure that the cables are stretched: if they are not, stretch them; if the cables are ok, perform the check procedure from the valve connector and for the instrument panel connector: if not ok restore; if ok, check the continuity of the Brown/Green and Black/Red cables: if not ok, restore the wiring harness; if ok, check the electrical characteristics of the engine and replace it, if necessary.
- If thermal protection: replace the instrument panel.
- If short circuit to negative: disconnect the valve connector and check with the key ON if there is ground continuity at PIN 3 of the connector: if there is ground, disconnect the instrument panel connector as well and if there is still ground, restore the Brown/Green cable and if there is not, replace the instrument panel; if there is no ground, with key ON, check if there is ground continuity at the connector PIN 2: if there is ground, disconnect the instrument panel connector as well and if there is still ground, restore the Black/Red cable and if there is not, replace the instrument panel; if there is no ground, check if PIN 3 or PIN 2 on the motor have ground continuity: if they do, replace the motor.
- If short circuit to positive or short circuit between the two cables: disconnect the instrument panel connector and check with key ON if there is voltage on PIN 3 or PIN 2 of the connector: if there is, restore the wiring harness; if there isn't, with key OFF and disconnecting the exhaust connector as well, check if the two cables are insulated one from the other: if they are not insulated, restore the wiring harness; if they are insulated, there is probably a short circuit to positive that may be inside the motor or the instrument panel: it will be necessary to try to replace one of the two components to identify which one of them is faulty.

P1503 Exhaust valve potentiometer

Electrical diagnosis:

- short circuit to positive / short circuit to negative, open circuit.

Error cause:

- Short-circuit to positive: excessive voltage has been detected on PIN 11 of the instrument panel.
- If short circuit to negative, open circuit: low voltage has been detected.

This error is indicated by lighting up in a fixed manner the MI warning light.

Troubleshooting:

- Short-circuit to positive: disconnect the valve connector and check with the key ON if there is ground continuity at PIN 5 of the connector: if there is voltage, disconnect the instrument panel connector as well, and if there is voltage, restore the wiring harness and if there is no voltage, replace the instrument panel; if there is no voltage, replace the motor.
- If short circuit to negative, open circuit: check the valve connector and the instrument panel connector: if they are not ok, restore; if they are ok, check continuity on the Brown/White: if not ok, restore; if ok, with the two connector disconnected, check the ground insulation: if there is ground continuity, disconnect the instrument panel connector as well, and if there is ground, restore the wiring harness and if there is no ground, replace the instrument panel; if there is no ground continuity, replace the motor.

DIAGNOSTIC TOOL: LOGIC ERRORS**P1500 Exhaust valve position****Functional diagnosis:**

- position error.

Error cause:

- The position indicate by the potentiometer does not correspond to the one set by the control unit.

This error is indicated by flashing the general warning light and by lighting up in a fixed manner the MI warning light.

Troubleshooting:

- Perform a mechanical check of the valve, check its normal rotation (with the cables disconnected from the motor, manually operate the cables and notice the movement regularity, checking the complete stroke of the valve with the correct operation of the return spring) and the absence of foreign objects that might obstruct its rotation: if not ok, restore; if ok, perform the check procedure fro the valve connector and for the instrument panel connectors (ay attention to oxidation signs) and check the cable resistance: if not ok, restore; if ok, with the cables disconnected, check at key ON the normal rotation of the electric motor and replace the motor (the potentiometer does not operate properly).

DIAGNOSTIC TOOL: ADJUSTABLE PARAMETERS

- Exhaust valve zero search

NOTES: The motor is placed in a reference position to be able to perform subsequently the correct mechanical stoppers search.

- Exhaust valve self-learning

NOTES: Performs the minimum and maximum mechanical stoppers search.

CAUTION

AFTER EACH MAINTENANCE OR CHECK OPERATION AT THE EXHAUST VALVE, PERFORM THE "EXHAUST VALVE CABLES CLEARANCE ADJUSTMENT" PROCEDURE.

The system consists of a throttle valve with return spring on the exhaust. The valve is closed by means of the two cables moved by an electric motor in its turn electrically connected to the instrument panel. The logic and the motor control, however, reside in the Marelli injection control unit that dialogues with the instrument panel via the CAN.

The motor consists of a potentiometer for controlling the position and a DC electric motor.

With the key set to ON, the valve self-cleaning is carried.

In the event of a malfunction (electric or mechanical) the valve could stay stuck in the closed position.

In the event of a CAN line malfunction the valve returns to the open position.

In the event of a check, removal or replacement of one or more system (cables, valve, motor) a calibration procedure is required.

CAUTION

BEFORE CARRYING OUT THIS OPERATION, CHECK THAT THE BATTERY VOLTAGE IS HIGHER THAN 12.5 V

CAUTION

WORK ON THE MOTOR OF THE EXHAUST THROTTLE VALVE ONLY WITH THE KEY SET TO "OFF" OR ONLY AFTER DISCONNECTING THE NEGATIVE POLE OF THE BATTERY.

CAUTION

NEVER REMOVE THE PULLEY FROM THE MOTOR

CAUTION

LOOSEN THE ADJUSTER SCREWS OF THE CONTROL CABLES BEFORE REMOVING THEM, TO PREVENT FORCING THEM.

CAUTION

BEFORE REMOVING THE CONTROL CABLES CHECK THAT THE MOTOR PULLEY IS IN THE "ZERO" POSITION. NEVER WORK ON THE CONTROL CABLES IF THE MOTOR PULLEY IS NOT IN THE "ZERO" POSITION

**ADJUSTING THE PLAY OF THE EXHAUST
THROTTLE VALVE CABLES**

- Check that the battery voltage is NOT below 12V;
- Check that the cylinders are in their seat and are NOT obstructed. If the cylinders are obstructed, put them in their seats straight;

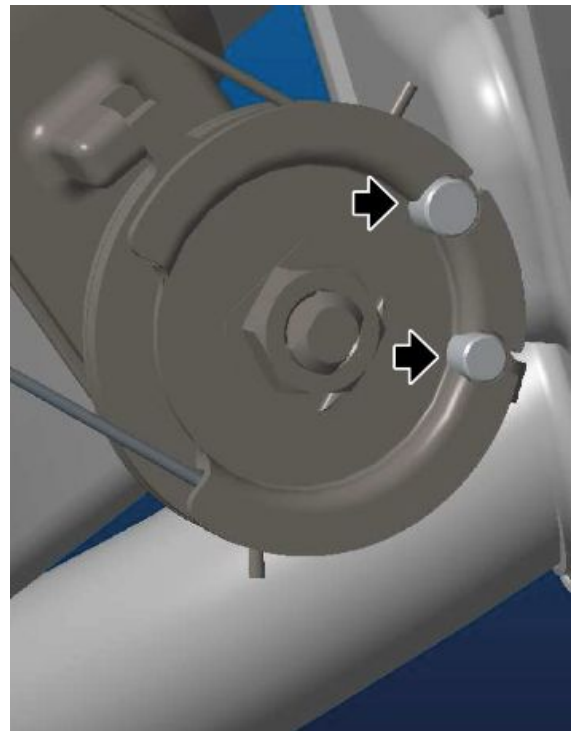

-
- Check that the valve spring on the silencer is in its seat



- Bring the two adjuster screws of the cables to zero, fully tightening them.

CAUTION

BRING BOTH NUTS OF THE TWO ADJUSTMENT SCREWS UP AGAINST THE SUPPORT PLATE, WELDED TO THE SILENCER;

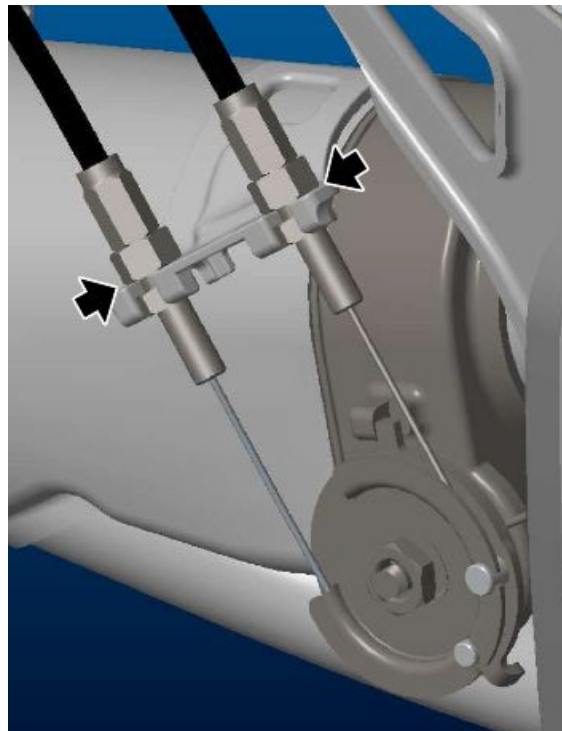

- Connect the PADS and carry out the "valve zero" (actuator in the corresponding valve fully open position);

CAUTION

CHECK THAT THE PULLEY HAS THE END-STOP RESTING AGAINST THE END-STOP OF THE SILENCER

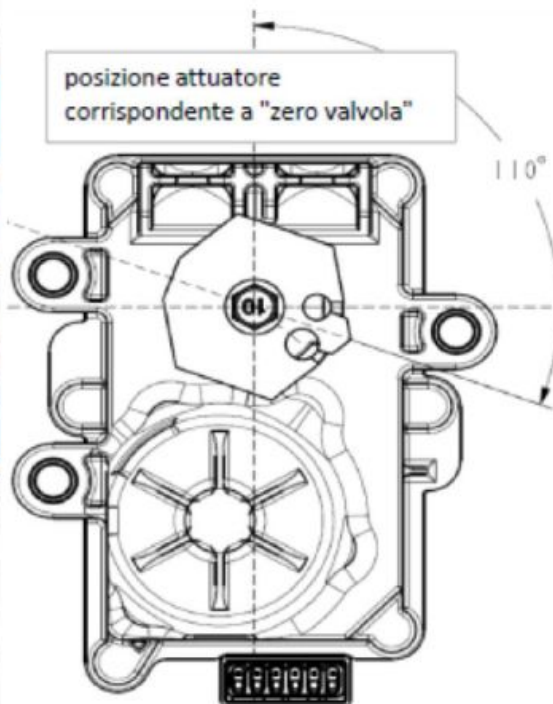
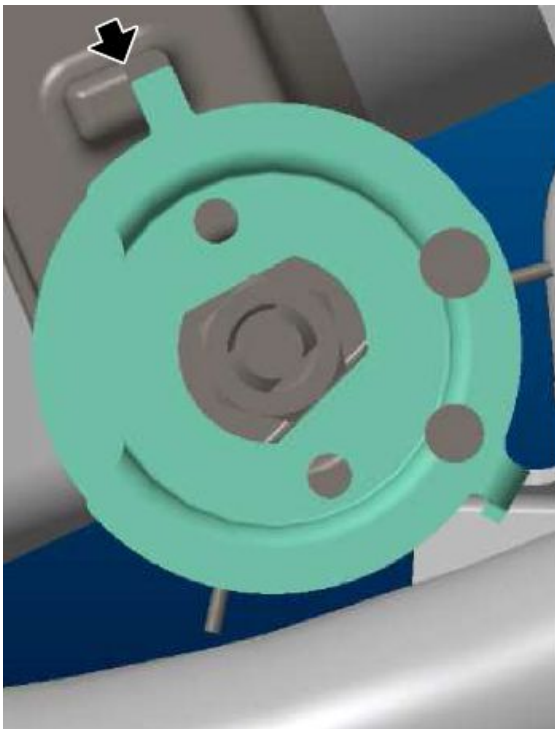

- Use the closing cable adjuster screw up to the value corresponding to the value "X" (see values in the table);

CAUTION

TURN THE ADJUSTER SCREW FULLY ANTI-CLOCKWISE (DIRECTION FOR TENSIONING THE ADJUSTER SCREW), KEEPING THE COUNTER-NUT STILL. DO NOT TURN CLOCKWISE FOR ANY CORRECTIONS, SINCE THE ADJUSTMENT IS DISTORTED DUE TO THE PLAY. IF IT GOES BEYOND THE REQUIRED VALUE, FULLY TIGHTEN THE ADJUSTER SCREW AND REPEAT THE ADJUSTMENT, CHECKING THAT THE PULLEY HAS THE END-STOP RESTING AGAINST THE END-STOP OF THE SILENCER.

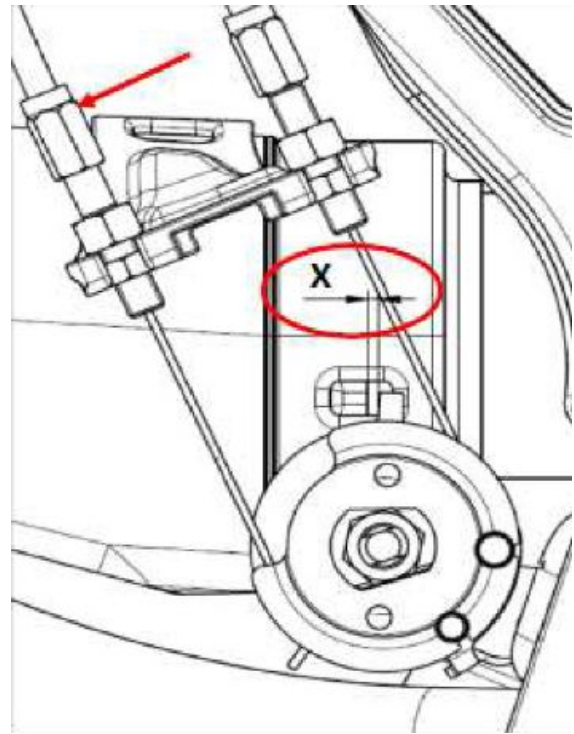

- Use the opening cable adjuster screw up to the value corresponding to the value "Y" (see values in the table);

CAUTION

TURN THE ADJUSTER SCREW FULLY ANTI-CLOCKWISE (DIRECTION FOR TENSIONING THE ADJUSTER SCREW), KEEPING THE COUNTER-NUT STILL. DO NOT TURN CLOCKWISE FOR ANY CORRECTIONS, SINCE THE ADJUSTMENT IS DISTORTED DUE TO THE PLAY. IF IT GOES BEYOND THE REQUIRED VALUE, FULLY TIGHTEN THE ADJUSTER SCREW AND REPEAT THE ADJUSTMENT.

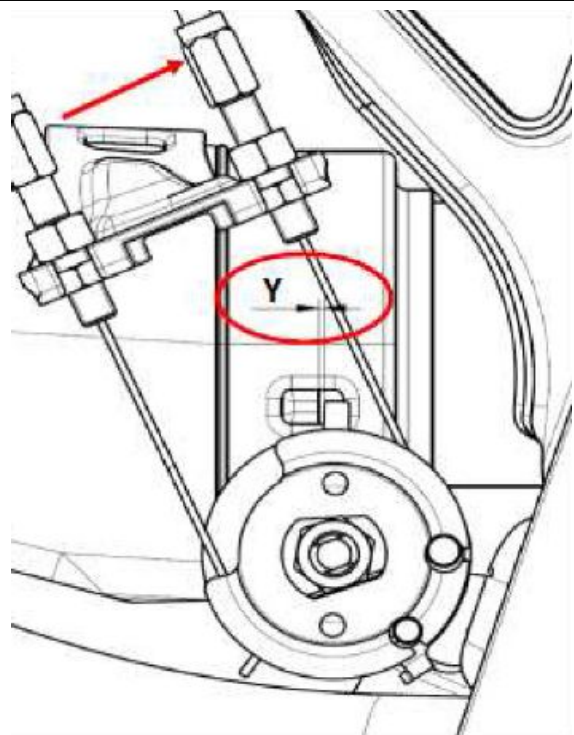

- Acquire the end position with the PADS (the actuator searches for the opening and closing travel limits);
- Open and close with the key and check that the cables are taut on the pulley;
- Visually check that the valve spring and the barrels are in their seats.

EXHAUST VALVE CLEARANCE

Condition of use	Closing cable - Value "X"	Opening cable - Value "Y"
New cables	4 +0.2mm (0.16 +0.0078 in)	1 -0.2mm (0.04 -0.0078 in)
At 1,000 km (621.37 mi) and at every service	3 -0.2 mm (0.12 -0.0079 in)	1 +0.2 mm (0.04 +0.0079 in)

NOTE

THE MEASUREMENT SHOULD BE CHECKED WITH THE FEELER GAUGE AT THE POINT SHOWN IN THE IMAGE BELOW

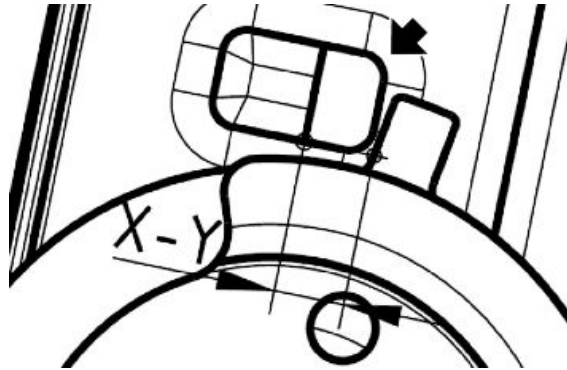
**Quick shift****Function:**

To indicate to the control unit the request for assisted gear shift.

Operation / Operating principle:

Two normally open switches that are closed to ground by operating the gearshift lever (either in UP or DOWN gear).

Electrical circuit diagram - Level in electrical circuit diagram:

Electronic gearbox.

Position on vehicle:

On the gearbox lever gear.

Connector position:

Under the fuel tank, on the left side, close to the rear big end.

Electrical specifications:

Normally open.

Pin-out:

- PIN1 - Power supply (+5 V)
- PIN2 - Signal (DOWN)
- PIN3 - Ground

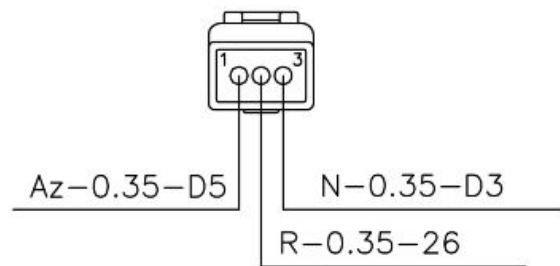
**DIAGNOSTIC TOOL: STATUSES****Quick shift command status (electronic gearbox):**

Engaged released.

DIAGNOSTIC TOOL: ELECTRICAL ERRORS

P1900 Quick Shift sensor

Electrical diagnosis:

- Short circuit to negative (at key ON) / Short circuit to positive (at key ON)

Error cause:

- If short circuit to negative: voltage equal to zero is detected at PIN 11 at key ON.
- If short circuit to positive: an excessive voltage is detected at PIN 11 at key ON.

This error is not indicated by lighting up any warning light.

Troubleshooting:

With disconnected sensor (voltage check):

- Check if between PIN 1 and PIN 2 there is a 500 Ohm resistance by bringing the lever in UP position; if NOT OK, replace the sensor;
- Check if between PIN 1 and PIN 2 there is a 1000 Ohm resistance by bringing the lever in DOWN position; if NOT OK, replace the sensor;
- Check if between PIN 1 and PIN 2 there is a 1000 Ohm resistance with the lever released; if NOT OK, replace the sensor;
- Check if between PIN 2 and PIN 3 there is a 1000 Ohm resistance by bringing the lever in UP position; if NOT OK, replace the sensor;
- Check if between PIN 2 and PIN 3 there is a 500 Ohm resistance by bringing the lever in DOWN position; if NOT OK, replace the sensor;
- Check if between PIN 2 and PIN 3 there is a 1000 Ohm resistance with the lever released; if NOT OK, replace the sensor;

With disconnected sensor (voltage check):

- Check if between PIN 3 and PIN 2 there is a 3.3 V voltage by bringing the lever in UP position; if NOT OK, replace the sensor;
- Check if between PIN 3 and PIN 2 there is a 1.6 V voltage by bringing the lever in DOWN position; if NOT OK, replace the sensor;
- Check if between PIN 3 and PIN 2 there is a 2.5 V voltage with the lever released; if NOT OK, replace the sensor;

If the above mentioned characteristics are fulfilled, it means that the sensor is functional and therefore it will be necessary to check the wiring harness upstream the connector.

- Red cable (PIN 2) in short circuit to ground.
- Red cable (PIN 2) in short circuit to positive.

NOTES: The control unit can not detect faults due to missing cable continuity.

P1906 Quick Shift functional diagnosis

Electrical diagnosis:

- blocked signal in UP / blocked signal in DOWN / signal not plausible

Error cause:

- If the signal is blocked in UP: internal spring of the switch blocked in UP
- If the signal is blocked in DOWN: internal spring of the switch blocked in DOWN
- If the signal is not plausible. this symptom is mainly caused by a gear shift (UP or DOWN) detected by the control unit without any change to the signal status (from "released lever" to UP or DOWN)

Troubleshooting:

This error necessarily involves an internal mechanical anomaly at the sensor; therefore, replace the component.

NOTES: The potential presence of the P1900 electrical error disables the recognition of the P1906 error.

a-PRC setting buttons

Function:

To signal to the control unit the request for modification of the a-PRC system settings.

Operation / Operating principle:

Either control (+) or (-) is made up of a deviator with both outputs electrically connected to the instrument panel: at the same time, the instrument panel sends the requested command to the Marelli ECU, via CAN line.

Electrical circuit diagram - Level in electrical circuit diagram:

Traction control.

Position on vehicle:

On the left side semi-handlebar.

Position of connector (if applicable):

Inside the top fairing and instrument panel mounting support.

Electrical specifications:

+ button: - 0 Ohm across PIN 2 and PIN 1 - Infinite resistance across PIN 2 and PIN 5; - button: 0 Ohm across PIN 3 and PIN 8 - infinite resistance across PIN 3 and PIN 4.

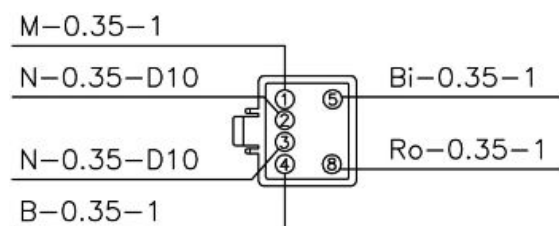
Pin-out:

- PIN 1: + 12 V power supply (green-brown)
- PIN 2: ground (black-black)
- PIN 3: ground (brown-black)
- PIN 4: + 12 V power supply (blue-blue)
- PIN 5: + 12 V power supply (yellow-white)
- PIN 8: power supply + 12 V (red - pink)

DIAGNOSTIC TOOL: STATUSES**"+" button:**

Pressed/Released/Invalid data due to open circuit error/Invalid data due to short circuit error.

"-" button:

Pressed/Released/Invalid data due to open circuit error/Invalid data due to short circuit error

DIAGNOSTIC TOOL: ELECTRICAL ERRORS**P0569 "-" command plausibility****Electrical diagnosis:**

- Open contacts/Closed contacts

Error cause:

- With open contacts, a voltage over zero is detected at the same time at PIN 22 and PIN 15 of the instrument panel.
- With closed contacts, zero voltage is detected at the same time at PIN 22 and PIN 15 of the instrument panel.

Troubleshooting:

The instrument panel expects to find, at either of the two PINs, a voltage over approx. 1 V and at the same time a voltage below 1 V at the other PIN; if this does not occur, the instrument panel outputs the information to the control unit that shows this error.

Indication on diagnostic tool "Invalid data due to short circuit error";

- CASE 1): if this status is displayed with control not activated only, it means that a voltage below 1V, instead of battery, is detected at PIN 22 of the instrument panel; disconnect the "-" button connector and read voltage at PIN 22 of the instrument panel: if voltage is below 1 V, it means that on the red cable there is a short circuit to ground; if voltage is above 1 V (approximately battery voltage), replace the "-" button sensor.
- CASE 2): if this status is displayed only with control activated, it means that at that moment a voltage below 1V, instead of battery, is being detected at PIN 15 of the instrument panel; disconnect the gearshift control connector and read voltage at PIN 15 of the instrument

panel: if voltage is below 1 V, it means that on the blue cable there is a short circuit to ground; if voltage is above 1 V (approximately battery voltage), replace the "-" button sensor.

Indication on diagnostic tool "Invalid data due to open circuit error";

- CASE 1): if this status is displayed only with control not activated, it means that circuit from PIN 15 to PIN 34 of the instrument panel is interrupted or that PIN 34 is not grounded: check the instrument panel connector and the "-" button connector: if they are not OK, restore; if they are OK, check continuity on the blue cable: if it is not OK, restore; if it is OK, check continuity on the black cable from the "-" button connector to PIN 34 of the instrument panel: if it is not OK, restore; if it is OK, check continuity of the "-" button from the "-" button connector (between brown cable and blue cable): if it is not OK, change the control; if it is OK, check, with key to ON, that the black cable is not grounded and then replace the instrument panel.
- CASE 2): if this status is displayed only with control activated, it means that circuit from PIN 22 to PIN 34 of the instrument panel is interrupted: check the instrument panel connector and the "-" button connector: if they are not OK, restore; if they are OK, check continuity on the red cable: if it is not OK, restore; if it is OK, check, with control activated, that there is not continuity of the "-" button from the "-" button connector (between brown cable and red cable) and then replace the control.

NOTES: The control unit can not detect faults due to failed cable continuity

P0570 "+" command plausibility

Electrical diagnosis:

- Open contacts/Closed contacts.

Error cause:

- With open contacts, a voltage over zero is detected at the same time at PIN 19 and PIN 20 of the instrument panel.
- With closed contacts, zero voltage is detected at the same time at PIN 19 and PIN 20 of the instrument panel.

Troubleshooting:

The instrument panel expects to find, at either of the two PINs, a voltage over approx. 1 V and at the same time a voltage below 1 V at the other PIN; if this does not occur, the instrument panel outputs the information to the control unit that shows this error.

Indication on diagnostic tool "Invalid data due to short circuit error";

- CASE 1): if this status is displayed with control not activated only, it means that a voltage below 1V, instead of battery, is detected at PIN 19 of the instrument panel; disconnect the "+" button connector and read voltage at PIN 19 of the instrument panel: if voltage is below 1 V, it means that on the white cable there is a short circuit to ground; if voltage is above 1 V (approximately battery voltage), replace the "+" button sensor.

- CASE 2): if this status is displayed only with control activated, it means that at that moment a voltage below 1V, instead of battery, is being detected at PIN 20 of the instrument panel; disconnect the gearshift control connector and read voltage at PIN 20 of the instrument panel: if voltage is below 1 V, it means that on the brown cable there is a short circuit to ground; if voltage is above 1 V (approximately battery voltage), replace the "+" button sensor.

Indication on diagnostic tool "Invalid data due to open circuit error";

- CASE 1): if this status is displayed only with control not activated, it means that circuit from PIN 20 to PIN 34 of the instrument panel is interrupted or that PIN 34 is not grounded: check the instrument panel connector and the "+" button connector: if they are not OK, restore; if they are OK, check continuity on the brown cable: if it is not OK, restore; if it is OK, check continuity on the black cable from the "+" button connector to PIN 34 of the instrument panel: if it is not OK, restore; if it is OK, check continuity of the "+" button from the "+" button connector (between black cable and green cable): if it is not OK, change the control; if it is OK, check, with key to ON, that the black cable is not grounded and then change the instrument panel.
- CASE 2): if this status is displayed only with control activated, it means that circuit from PIN 19 to PIN 34 of the instrument panel is interrupted: check the instrument panel connector and the "+" button connector: if they are not OK, restore; if they are OK, check continuity on the white cable: if it is not OK, restore; if it is OK, check, with control activated, that there is no continuity of the "+" button from the "+" button connector (between the black cable and the yellow cable) and then replace the control.

Inertial sensor platform (sensor box)

Function:

To transmit information about the motorcycle dynamics to the Marelli control unit (e.g.: yaw rate).

Electrical circuit diagram - Level in electrical circuit diagram:

Traction control.

Position on vehicle:

Fastened to the fuel tank, under the seat.

Connector position:

On the platform

Pin-out:

- Pin 1: ground lead (black)
- Pin 2: "L" CAN line (white/black)
- Pin 3: "H" CAN line (orange)

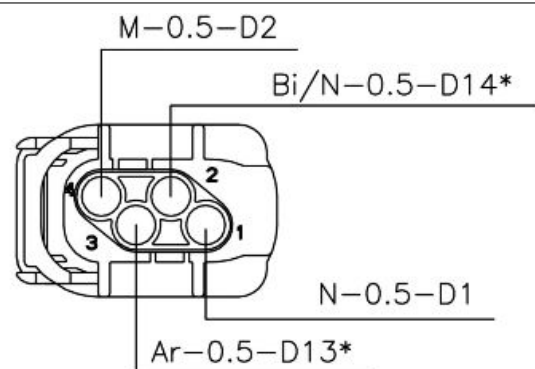

- Pin 4: supply (brown)

DIAGNOSTIC TOOL: ELECTRICAL ERRORS

-

DIAGNOSTIC TOOL: LOGIC ERRORS**P1901 Ax acceleration sensor plausibility****Functional diagnosis:**

- Faulty sensor/Signal not valid

Troubleshooting:

With faulty sensor, the component inside the control unit is damaged and replacement of the control unit is recommended. With signal not valid, the sensor has generated a signal out of range that is still sent to the injection control unit together with the relevant error.

NOTE: The instrument panel does not indicate the presence of this error even in the ATT status.

NOTE**THIS ERROR DISABLES THE TRACTION CONTROL.****P1902 Az acceleration sensor plausibility****Functional diagnosis:**

- Faulty sensor/Signal not valid

Troubleshooting:

With faulty sensor, the component inside the control unit is damaged and replacement of the control unit is recommended. With signal not valid, the sensor has generated a signal out of range that is still sent to the injection control unit together with the relevant error.

NOTE: The instrument panel does not indicate the presence of this error even in the ATT status.

NOTE**THIS ERROR DISABLES THE TRACTION CONTROL.****P1903 Yaw sensor plausibility****Functional diagnosis:**

- Faulty sensor/Signal not valid

Troubleshooting:

With faulty sensor, the component inside the control unit is damaged and replacement of the control unit is recommended. With signal not valid, the sensor has generated a signal out of range that is still sent to the injection control unit together with the relevant error.

NOTE: The instrument panel does not indicate the presence of this error even in the ATT status.

NOTE**THIS ERROR DISABLES THE TRACTION CONTROL.****P1904 Roll sensor plausibility****Functional diagnosis:**

- Faulty sensor/Signal not valid

Troubleshooting:

With faulty sensor, the component inside the control unit is damaged and replacement of the control unit is recommended. With signal not valid, the sensor has generated a signal out of range that is still sent to the injection control unit together with the relevant error.

NOTE: The instrument panel does not indicate the presence of this error even in the ATT status.

NOTE**THIS ERROR DISABLES THE TRACTION CONTROL.****P1905 Wheel stand timeout error****Functional diagnosis:**

Timeout error

Error cause:

- If this error is displayed, it means that the wheel stand control software detected an abnormal behaviour of the motorcycle.

Troubleshooting:

With faulty sensor, the component inside the control unit is damaged and replacement of the control unit is recommended. With signal not valid, the sensor has generated a signal out of range that is still sent to the injection control unit together with the relevant error.

NOTE: The instrument panel does not indicate the presence of this error even in the ATT status.

NOTE**THIS ERROR DISABLES THE TRACTION CONTROL.**

Connectors

ECU

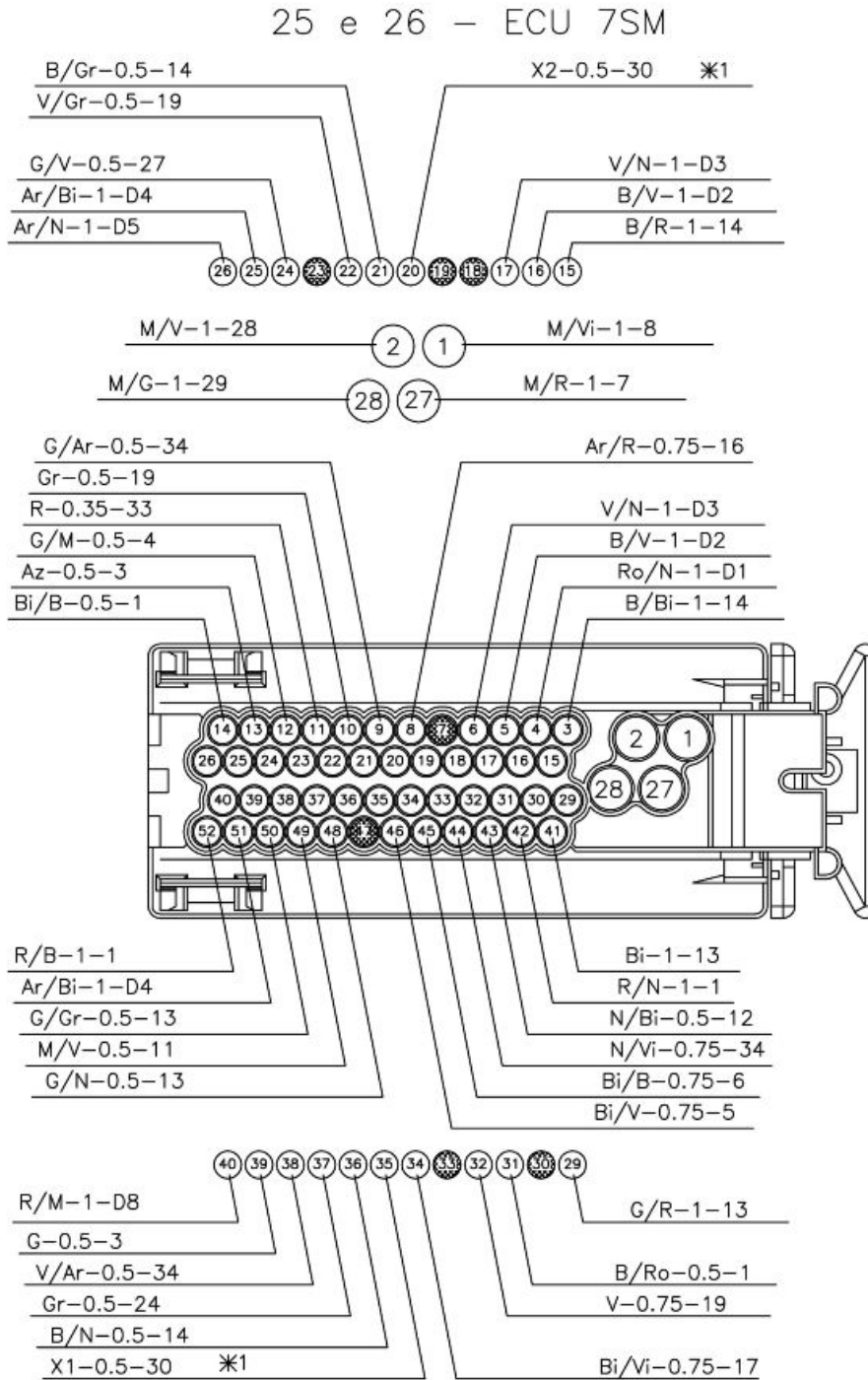

Engine pinout key:

- PIN 1 - Cylinder 4 coil control output
- PIN 2 - Cylinder 3 coil control output
- PIN 3 - Output for front throttle valve engine command (+)
- PIN 4 - Sensor ground 2

- PIN 5 - Power ground 1
- PIN 6 - Sensor ground 1
- PIN 7 -
- PIN 8 - Cylinder 1 lower injector command output
- PIN 9 - Lambda sensor 2 input (+)
- PIN 10 - Lambda sensor 1 input (+)
- PIN 11 - Electronic gearbox signal (down)
- PIN 12 - Water temperature sensor input
- PIN 13 - B track handle input
- PIN 14 - K serial line for diagnosis
- PIN 15 - Output for front throttle valve engine command (-)
- PIN 16 - Power ground 2
- PIN 17 - Sensor ground 1
- PIN 18 -
- PIN 19 -
- PIN 20 - Engine rpm sensor input (-)
- PIN 21 - Front throttle valve potentiometer 2 signal input
- PIN 22 - Lambda sensor 1 input (-)
- PIN 23 -
- PIN 24 - Rear cylinders intake pressure sensor input
- PIN 25 - +5 V reference voltage output: A-C tracks, rear throttle valves and pressure sensor (map)
- PIN 26 - +5 V reference voltage output: B-D tracks, front throttle valves
- PIN 27 - Cylinder 2 coil command output
- PIN 28 - Cylinder 1 coil command output
- PIN 29 - Output for rear throttle valve engine command (-)
- PIN 30 -
- PIN 31 - Recovery logic (stop light) relay command output
- PIN 32 - Lambda 1 heater command output
- PIN 33 -
- PIN 34 - Cylinder 3 lower injector command output
- PIN 35 - Engine rpm sensor input (+)
- PIN 36 - Front throttle valve potentiometer 1 signal input
- PIN 37 - Air temperature sensor input
- PIN 38 - Lambda 2 sensor input (-)
- PIN 39 - A track handle input
- PIN 40 - Key input
- PIN 41 - Output for rear throttle valve engine command (+)

- PIN 42 - Key input
- PIN 43 - Secondary air valve command output
- PIN 44 - Lambda 2 heater command output
- PIN 45 - Cylinder 4 lower injector command output
- PIN 46 - Cylinder 2 lower injector command output
- PIN 47 -
- PIN 48 - Rear throttle valve potentiometer 1 signal input
- PIN 49 - Front cylinders intake pressure sensor input
- PIN 50 - Rear throttle valve potentiometer 2 signal input
- PIN 51 - +5 V reference voltage output: A-C tracks, rear throttle valves and pressure sensor (map)
- PIN 52 - Control unit direct power supply

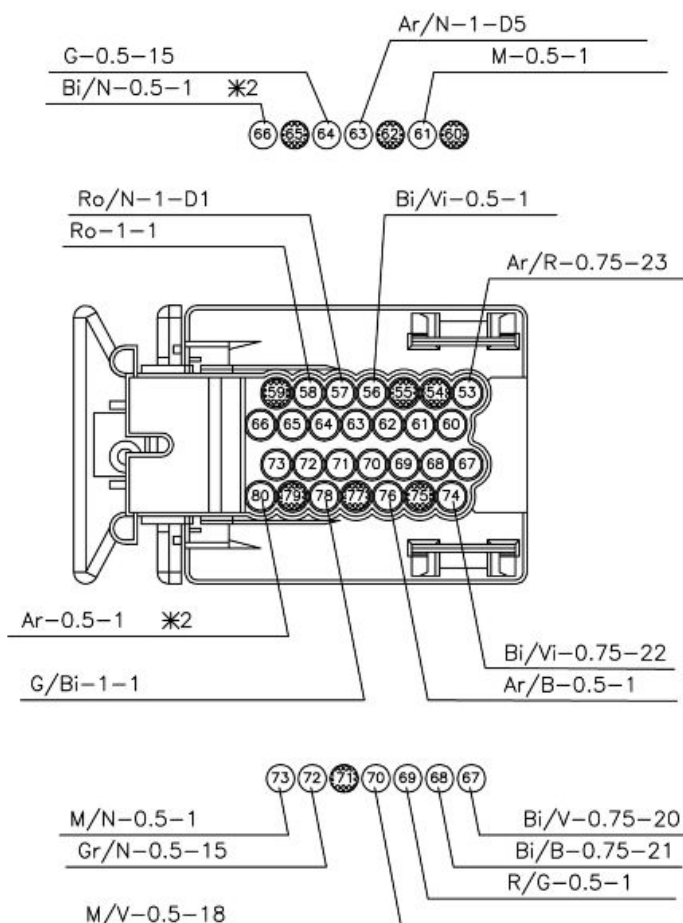

Vehicle pinout key:

- PIN 53 - Cylinder 1 upper injector command output

- PIN 54 -
- PIN 55 -
- PIN 56 - Clutch sensor input
- PIN 57 - Sensor ground 2
- PIN 58 - Engine start button input
- PIN 59 -
- PIN 60 -
- PIN 61 - Electric fan relay command output
- PIN 62 -
- PIN 63 - +5 V reference voltage output: B-D tracks, front throttle valves
- PIN 64 - Neutral input
- PIN 65 -
- PIN 66 - L CAN line (high speed)
- PIN 67 - Cylinder 2 upper injector command output
- PIN 68 - Cylinder 4 upper injector command output
- PIN 69 - Start-up relay command output
- PIN 70 - Side stand input
- PIN 71 -
- PIN 72 - Gear sensor input
- PIN 73 - Injection relay command output
- PIN 74 - Cylinder 3 upper injector command output
- PIN 75 -
- PIN 76 - Clutch sensor input
- PIN 77 -
- PIN 78 - "Engine stop" input
- PIN 79 -
- PIN 80 - H CAN line (high speed)

Engine-vehicle connector pinout key:

- PIN A1 - Battery
- PIN A2 -
- PIN A3 - Safety
- PIN A4 -
- PIN A5 -
- PIN A6 - Clutch released
- PIN A7 - Analogic ground
- PIN A8 - Battery

- PIN B1 - Injection power supply
- PIN B2 - CAN line (high)
- PIN B3 - CAN line (low)
- PIN B4 - Key
- PIN B5 - Electric fan relay control
- PIN B6 -
- PIN B7 -
- PIN B8 - Power ground 1
- PIN C1 - Injection power supply
- PIN C2 - K serial line for diagnosis
- PIN C3 - Clutch engaged
- PIN C4 - "Start engine" button
- PIN C5 - Start-up
- PIN C6 - Injection relay
- PIN C7 - Engine stop
- PIN C8 - Power ground 2

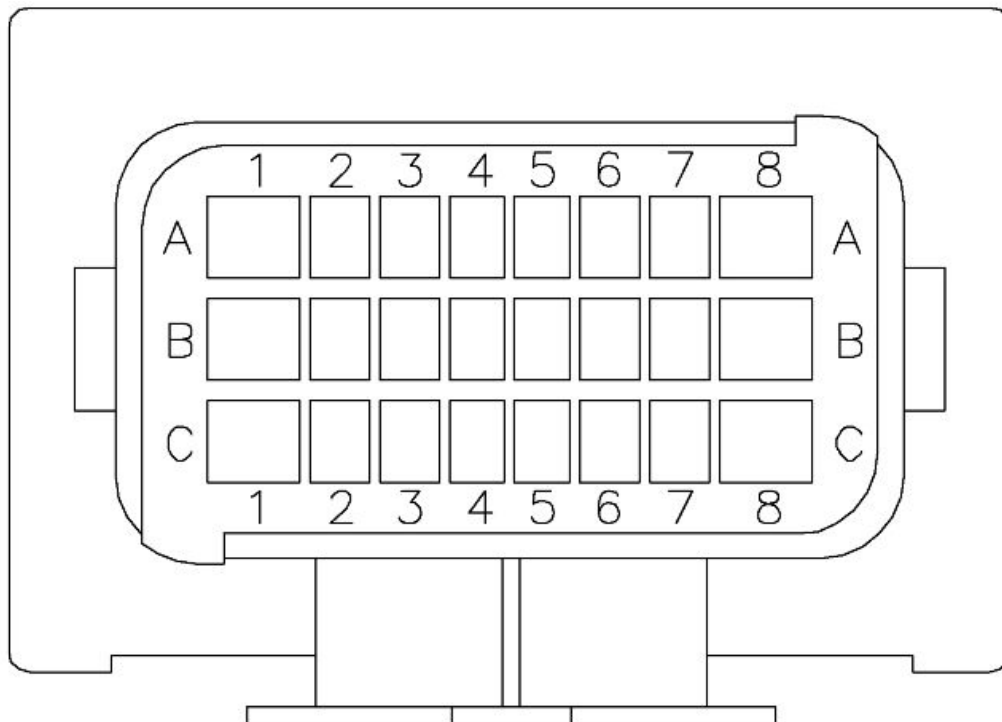

Dashboard

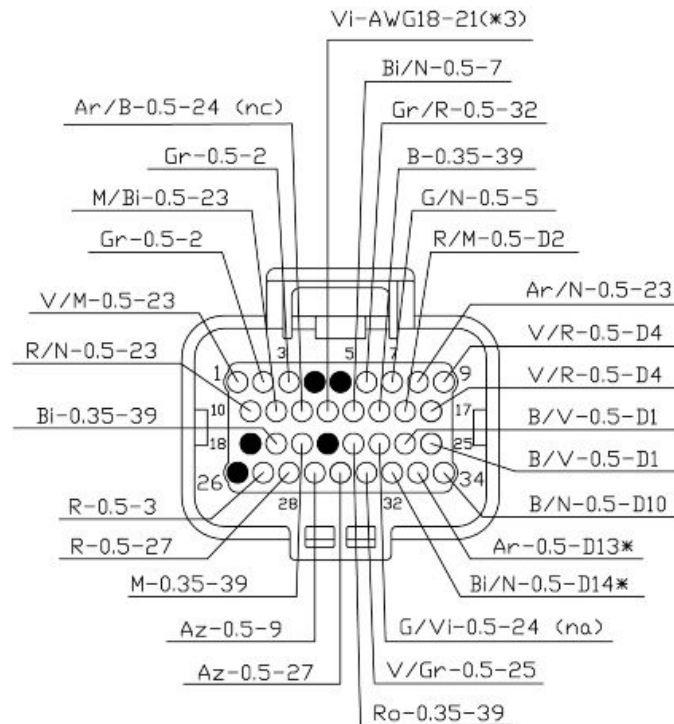

Instrument panel pinout key:

- PIN 1 - Valve command at the exhaust (A terminal)
- PIN 2 - Antenna 1
- PIN 3 - Antenna 2
- PIN 4 -
- PIN 5 -
- PIN 6 - Timer set-up
- PIN 7 - Light relay
- PIN 8 - +5 V reference voltage output
- PIN 9 - Battery positive
- PIN 10 - Valve command at the exhaust (B terminal)
- PIN 11 - Power signal
- PIN 12 - Rear stop switch
- PIN 13 - Oil pressure
- PIN 14 - High beam lights IN
- PIN 15 - Normally closed "-" TC switch
- PIN 16 - Key positive
- PIN 17 - Battery positive
- PIN 18 -
- PIN 19 - Normally open "+" TC switch

- PIN 20 - Normally closed "+" DC switch
- PIN 21 -
- PIN 22 - Normally open "-" TC switch
- PIN 23 - Rear stop switch
- PIN 24 - Ground
- PIN 25 - Ground
- PIN 26 -
- PIN 27 - RH front arrow
- PIN 28 - RH rear arrow
- PIN 29 - LH front arrow
- PIN 30 - LH rear arrow
- PIN 31 - Fuel reserve
- PIN 32 - L CAN line (high speed)
- PIN 33 - H CAN line (high speed)
- PIN 34 - Sensor ground

ABS Modulator

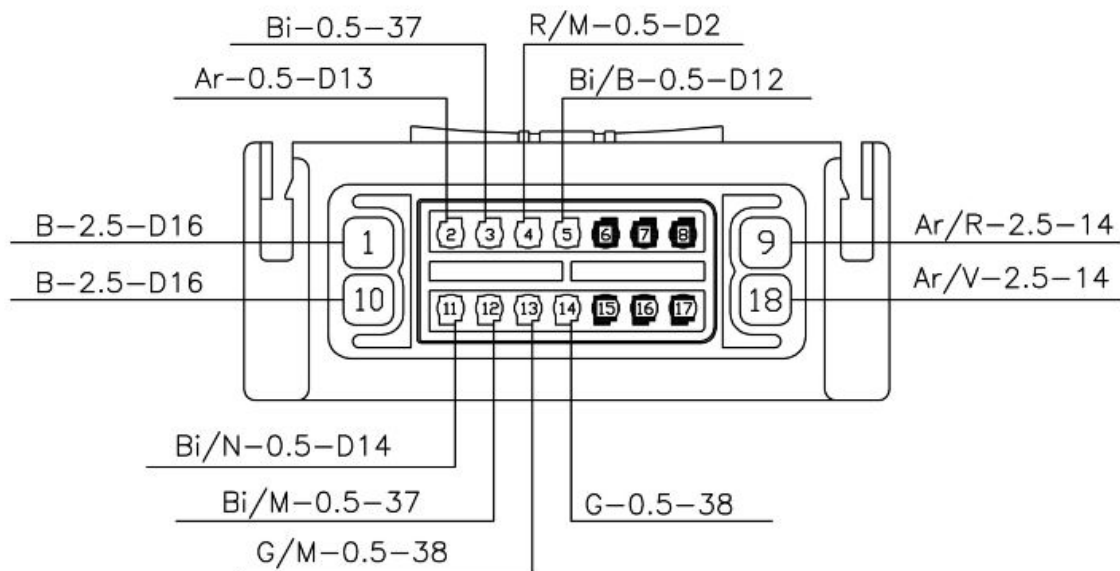

ABS control unit pinout key:

- PIN 1 - Valve ground and ECU
- PIN 2 - H CAN line (high speed)
- PIN 3 - Front speed sensor input

- PIN 4 - Key positive (ECU)
- PIN 5 - K serial line for diagnosis
- PIN 6 -
- PIN 7 -
- PIN 8 -
- PIN 9 - Battery positive for valves
- PIN 10 - Pump engine ground
- PIN 11 - L CAN line (high speed)
- PIN 12 - Front speed sensor positive
- PIN 13 - Rear speed sensor positive
- PIN 14 - Rear speed sensor input
- PIN 15 -
- PIN 16 -
- PIN 17 -
- PIN 18 - Battery positive for pump engine

Can line

Function

Allows the communication between the Marelli injection control unit, the instrument panel, the ABS modulator and the LH lights switch.

Operation / Operating principle

CAN SYSTEM ADVANTAGES

A CAN line (Area network controller) is a connection between various electronic devices of a vehicle, set up as a computer network (internet). The CAN network allowed to significantly simplify the layout of the electric system and consequently its total mass. With this communication line, it was possible to avoid useless duplications of various sensors on the motorcycle, since the signals coming from them are divided among the three electronic processing units (instrument panel, control unit and ABS modulator) and the LG light switch.

- Cable number reduction: The CAN line travels through a twisted cable to several nodes.
- These nodes can also isolate the errors without causing a system breakdown (FaultsConfination).
- Immunity to interference: the signal travels through two cables and the signal reading is differential (voltage difference between the two signals on both cables). If the two signals are disturbed by an external factor, their difference remains unaltered.
- Communication speed: The messages travel at a bit rate of approximately 500 kbps (depending on the sent data package, the information may arrive at the nodes in a time carrying from 4 ms to 100 ms).

CAN PROTOCOL (CONT. NETWORK AREA)

The communication protocol is CSMA/CD (Carrier Sense Multiple Access w/ Collision Detection). In order to transmit, every node must first check that the BUS (the connection among all devices) is free before attempting to send a message with BUS (Carrier Sense).

If during this period there is no activity on BUS, every node has the same chance to send a message (Multiple Access). If two nodes start transmitting simultaneously, the nodes recognise the "collision" (Collision Detection) and initiate an exchange action based on message priority (messages remain unaltered during exchange and there is no delay for high priority messages).

CAN protocol is based on messages and not on addresses. The message itself is divided into several parts (frames), each of which has a meaning: message priority, data contained, error detection, reception confirmation, etc.

Every network node receives all the messages sent through the BUS (with reception confirmation or error messages) and each node decides if the message is to be processed or rejected. Besides, every node can request information from the other nodes (RTR = Remote Transmit Request).

Level in electrical circuit diagram:

CAN Line

Electrical specifications:

- between PIN 66 and 80 of the control unit: approx. 120 Ohm
- between PIN 32 and 33 of the instrument panel: approx. 120 Ohm

Pin out:

- Line L: White/Black cable between PIN 66 and the Marelli control unit. PIN 32 of the instrument panel, PIN 3 of the LH lights switch and PIN 11 of the ABS modulator.
- Line H: Orange cable between PIN 80 of the Marelli control panel, PIN 33 of the instrument panel, PIN 4 of the LH lights switch connector and PIN 2 of the ABS modulator.

CAUTION

BEFORE CARRYING OUT ANY TROUBLESHOOTING, CAREFULLY READ THE GENERAL TROUBLESHOOTING CONCEPTS FOR ELECTRICAL DEVICES AT THE BEGINNING OF THE CHECK AND CONTROL SECTION IN THE ELECTRICAL SYSTEM CHAPTER.

DIAGNOSTIC TOOL: ELECTRICAL ERRORS**U0001 CAN line missing signals****Electrical diagnosis:**

- Bus Off.

Error cause:

- No communication on CAN line (PIN 66 and/or PIN 80): problem in the entire network (for example interruption or short circuit to positive or short circuit to ground).

This error is indicated by lighting up in a fixed manner the MI warning light.

Troubleshooting:

- Carry out the Marelli control unit and the engine-vehicle wiring harness connectors check procedure: if not OK, restore; if OK, check the ground insulation of the two CAN lines from PIN 66 and PIN 80 of the VEHICLE connector: if not ok, restore the wiring harness; if ok, check the continuity of the CAN lines from the VEHICLE connector of the Marelli control unit to the instrument panel connector, or to the LH lights switch connector, or to the ABS modulator connector: if not ok, restore the wiring harness; if ok, check that the lines are not in short circuit to positive, testing all 5 connectors (Marelli control unit, engine-vehicle wiring harness connector, instrument panel connector, LH lights switch connector, ABS modulator connector) with 1 connector disconnected at a time and turning the key to ON position: If not OK, restore; if OK, replace the Marelli control unit.

NOTE

THIS ERROR DISABLES THE TRACTION CONTROL AND THE CRUISE CONTROL.

U0002 CAN Line "Mute Node"**Electrical diagnosis:**

- Mute Node.

Error cause:

- The injection ECU cannot send CAN signals; it receives signals from the instrument panel: the control unit may need replacing.

This error is indicated by lighting up in a fixed manner the general warning light.

Troubleshooting:

- Replace the Marelli control unit.

NOTE

THIS ERROR DISABLES THE TRACTION CONTROL AND THE CRUISE CONTROL.

U0140 CAN line to the instrument panel**Electrical diagnosis:**

- no signal.

Error cause:

- No signal is received from the instrument panel.

This error is indicated by lighting up in a fixed manner the general warning light.

Troubleshooting:

- Check the connector of the instrument panel: if not OK, restore; if OK, check the continuity of the two lines from the instrument panel connector to the VEHICLE connector of the Marelli control unit: if not OK, restore the cable harness; if OK, replace the instrument panel.

NOTE

THIS ERROR DISABLES THE TRACTION CONTROL AND THE CRUISE CONTROL.

U1125 Frame counter "Sensor Box" CAN line diagnosis**Electrical diagnosis:**

- Intermittent signal or communication error

Error cause:

- Probable bad contact in the CAN line.

This error is not indicated even in the ATT status.

Troubleshooting:

- Perform the check procedure for the VEHICLE connector at PIN 66 and PIN 80 an of the PIN B2 and PIN B3 of the engine-vehicle wiring harness connector; if it is NOT OK restore and if it is OK perform the check procedure for PIN 2 and PIN 3 of inertial platform (Sensor Box) connector; if NOT OK restore and if OK check the general operation of the Marelli control unit and of the inertial platform (Sensor Box); in case of anomalies, replace the part concerned.

NOTE

THIS ERROR DISABLES THE TRACTION CONTROL.

U1129 "LH handlebar" CAN line diagnosis**Electrical diagnosis:**

- no signal.

Error cause:

- No signal is received from the LH light switch.

This error is indicated by lighting up in a fixed manner the general warning light.

Troubleshooting:

- Check the connector of LH light switch: if not ok, restore; if ok, check the continuity of the two lines from the LH light switch connector to the VEHICLE connector of the Marelli control unit: if not ok, restore the wiring harness; if ok, replace the light switch.

NOTE

THIS ERROR DISABLES THE CRUISE CONTROL.

U1130 "LH handlebar" frame counter CAN line diagnosis**Electrical diagnosis:**

- Intermittent signal or communication error

Error cause:

- Probable bad contact in the CAN line.

This error is not indicated even in the ATT status.

Troubleshooting:

- Perform the check procedure for the VEHICLE connector at PIN 66 and PIN 80 an of the PIN B2 and PIN B3 of the engine-vehicle wiring harness connector; if it is not OK restore and if it is OK perform the check procedure for PIN 3 and PIN 4 of the LH light switch

connector; if NOT OK restore and if OK check the general operation of the Marelli control unit and of the LH light switch; in case of anomalies, replace the part concerned.

NOTE

THIS ERROR DISABLES THE CRUISE CONTROL.

DIAGNOSTIC TOOL: LOGIC ERRORS**U0121 "ABSENT NODE" ABS control unit****Functional diagnosis:**

Missing signal / signal not plausible/ config error

Error cause:

- Missing communication of the ABS control unit to the CAN line

This error is indicated by lighting up in a fixed manner the MI warning light.

Troubleshooting:

- Disconnect the ABS control unit connector and check that there is no dirty, oxidised or damaged PIN; if not ok, restore; if ok, check the continuity between the ABS control unit PIN 2 and PIN 11 and PIN 66 and PIN 80 of the VEHICLE connector of the marelli control unit; if not ok, restore; if ok, check the continuity between the ABS control unit PIN 2 and PIN 11 and PIN 32 and PIN 33 of the instrument panel; if not ok, restore; if ok, check the continuity between the ABS control unit PIN 2 and PIN 11 and PIN 3 and PIN 4 of the LH light switch; if not ok restore, if ok check that there is no continuity between the two cables of the CAN line (L and H); if not ok restore, if ok check that there is no continuity between vehicle ground and the battery positive; If not ok, restore; if ok, replace the ABS control unit.

NOTE

THIS ERROR DISABLES THE TRACTION CONTROL AND THE CRUISE CONTROL.

U0125 CAN line sensor box diagnosis**Functional diagnosis:**

- No signal/Configuration error

Error cause:

- If there is missing signal, no signal arrives from the inertial platform (Sensor Box). In case of configuration error, some devices are present (e.g. Sensor Box) that were not foreseen in the vehicle configuration stored in the control unit.

This error is indicated by lighting up in a fixed manner the general warning light.

Troubleshooting:

- Missing signal - Perform the check procedure for PIN 2 and PIN 3 of the inertial platform (Sensor box) connector, for PIN B2 and PIN B3 of the vehicle-engine connector, for pin 66 and 80 of the Marelli control unit VEHICLE connector: if NOT OK restore, if OK with key OFF, disconnect: a) the ABS control unit connector, b) the connector of the inertial platform (Sensor box) and check the continuity between PIN 3 of the inertial platform (Sensor box) and PIN 2 of the ABS control unit: if NOT OK, replace the vehicle wiring harness, if OK,

check the continuity between PIN 2 of the inertial platform (Sensor box) and PIN 11 of the ABS control unit; if NOT OK, replace the wiring harness, if OK, check the correct power supply to PIN 4 (12V) and the grounding of ABS control unit PIN 1: if NOT OK, restore the wiring harness, if OK, replace the inertial platform (sensor box)

- Configuration error - Open the diagnostic tool devices status page to check if the control unit setting is actually consistent with the motorcycle setting. Example: if the vehicle is equipped with inertia sensor platform (Sensor box), the correct status we should find on the diagnostic tool devices status page will be: Aprilia Traction Control Performance (in a bend) PRESENT. While on a vehicle equipped with inertia sensor platform (Sensor box) and diagnostic tool indication: Aprilia Traction Control Performance (in a bend) NOT PRESENT update the control unit

NOTE

THIS ERROR DISABLES THE TRACTION CONTROL.

U1121 Diagnosis of "ABS control unit" CAN line or CLF frame counter**Functional diagnosis:**

- Signal absent

Error cause:

- If there is no signal, no signal is received from the ABS control unit.

This error is indicated by lighting up in a fixed manner the MI warning light.

Troubleshooting:

- Missing signal - Perform the check procedure for pin 2 and 11 of the ABS control unit connector, for pin 66 and 80 of the Marelli control unit vehicle connector: if NOT OK, restore; if OK with key OFF, disconnect the ABS control unit connector; if NOT OK replace the wiring harness, if OK check the correct power supply to PIN 18 (12V) and the grounding of ABS control unit PIN 1; if NOT OK, restore the wiring harness, if OK, replace the ABS control unit.

NOTE

THIS ERROR DISABLES THE TRACTION CONTROL AND THE CRUISE CONTROL.

P1800 Rear wheel radius learning diagnosis**Functional diagnosis:**

- CAN error while learning / Signal not plausible.

Error cause:

- In case of CAN error during acquisition, system warns that the procedure can not be completed due to a communication problem on the CAN line.
- If the signal is not plausible, there was a transcription error of the value of the rear wheel radius from the non volatile memory (EEPROM) to the volatile memory (RAM) at key ON. In this case the default value is used.

This error is indicated by lighting up in a fixed manner the MI warning light.

NOTE

THIS ERROR DISABLES THE TRACTION CONTROL.**P0564 Cruise control button - Brake switch****Electrical diagnosis:**

- (brake sensors errors) connect to the instrument panel diagnosis

Error cause

- Malfunction or communication interruption from the button on the light switch control.
- Malfunction or rupture of the rear brake switch

This error is indicated by lighting up in a fixed manner the general warning light.

Troubleshooting

- connect the diagnostic tool and check the correct activation status of the brake levers concerning the brake switches that are physically connected to the instrument panel: if OK, check the stability of the connections, if NOT ok, check the proper state of maintenance of the rear brake connector; if NOT OK, restore, if OK, maintaining the switch fitted on the vehicle, check with a tester that there is no continuity between PIN 1 and PIN 3 of the switch with the lever engaged/released; if NOT OK, replace the rear switch, if OK, check that there is continuity between PIN 2 and PIN 3 of the switch with the brake lever released; if NOT OK, replace the switch, if OK, check that there is continuity between PIN 1 and PIN 2 with the brake lever engaged; if NOT OK, replace the switch, if OK, check that there is continuity between PIN 1 and PIN 12 of the instrument panel;
- If the instrument panel does not detect errors related to the brake switches, operate several times the cruise control. If the problem persists, replace the LH light switch.

NOTE**THIS ERROR DISABLES THE CRUISE CONTROL.**

Presà USB

Rimozione

- Unscrew and remove the screws (1)
Remove the top fairing glass from the seats of the motorcycle



- Unscrew and remove the two screws (2); Remove the instrumentation lid

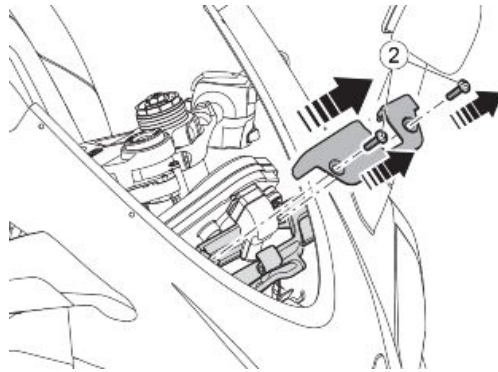

- Move the instrument panel to the right, so as to remove it from its seat.
- Once released, move the instrument panel without disconnecting the connectors from it, so as to be able to easily access the USB port connector.

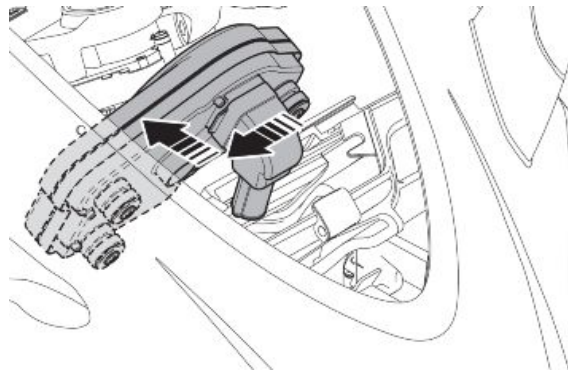

- Disconnect the USB wiring connector (3) from the connector of the wiring harness on the vehicle (4)

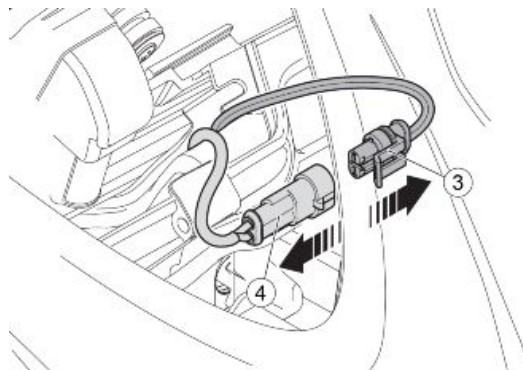

- Remove the fixing screw (6) of the support bracket (7) paying attention to recover the elastic washer (8)
- Remove the USB port

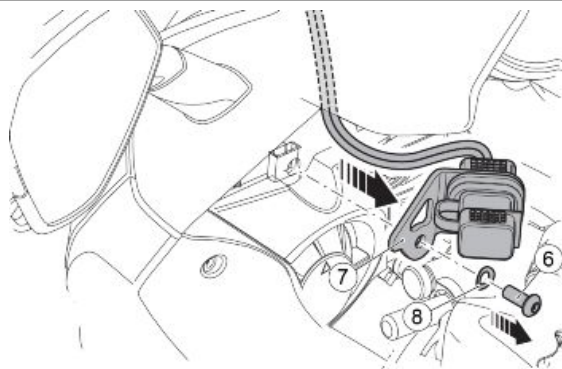

Installazione

- Unscrew and remove the screws (1)
Remove the top fairing glass from the seats of the motorcycle

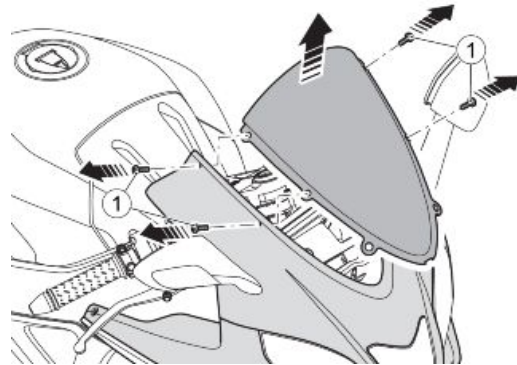

- Unscrew and remove the two screws (2); Remove the instrumentation lid

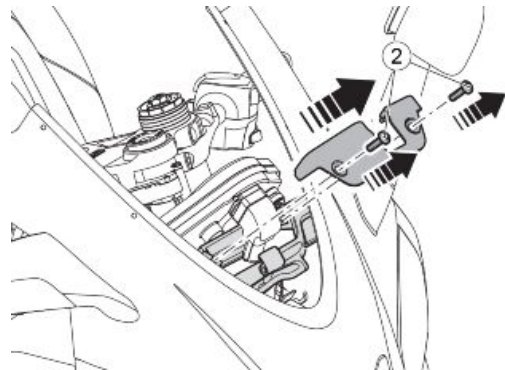

- Move the instrument panel to the right, so as to remove it from its seat.
- Once released, move the instrument panel without disconnecting the connectors from it, so as to be able to easily access the wiring harness connector on the vehicle.

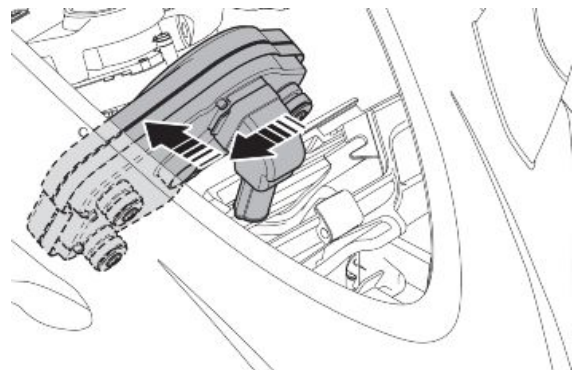

- Insert the rubber gasket housing the USB port (4) into the support bracket (3).
- Then insert the USB port (5) in the rubber gasket (4).
- Operating from the left vehicle side, insert the nut in the corresponding housing on the headlamp.
- Place the wiring harness of the USB cable (6) on the vehicle, making it pass through the headlamp and the instrumentation support and recover the connector (7) so as it is inside the instrumentation support compartment.

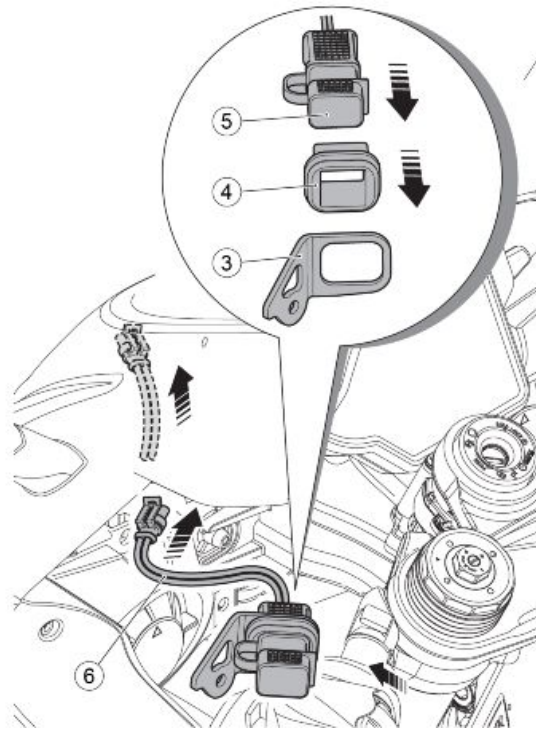

- Connect the vehicle wiring harness connector (7) to the USB wiring harness connector (8) and place it carefully inside the instrumentation support compartment

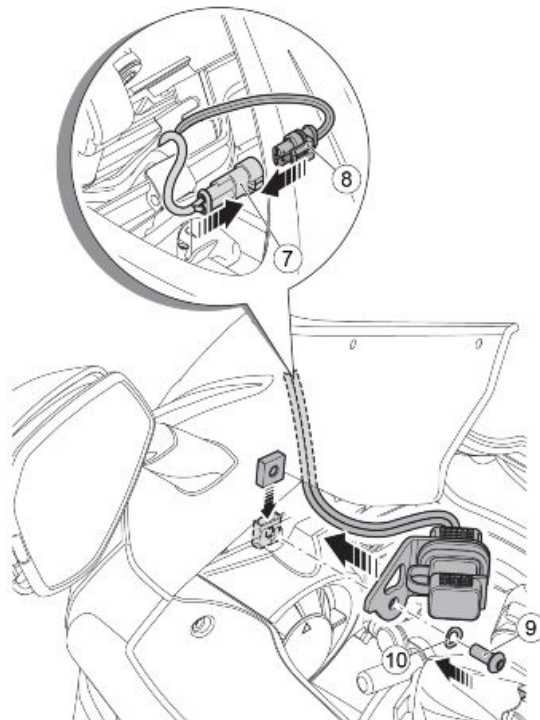

- Fix the USB supporting clamp (3) to the headlamp with the screw (9) provided with the washer (10)

Locking torques (N*m)

USB port support bracket fixing 6 Nm (4.43 lb ft)

Aprilia V4-MP Technology

Sincronizzazione

To use the system V4-MP the synchronisation that differs depending on the operating system must be performed:

IOS OPERATING SYSTEM

- Turn the ignition switch of the motorcycle ON with the PMP ECU correctly connected.
- Open the App settings clicking on the icon



- In the page settings click on the "Blue-Tooth" menu



- Inside the "BlueTooth" page if Blue-Tooth is not active, to activate it press the button shown
- BlueTooth active = Green button



- Once Bluetooth is enabled, the smartphone automatically searches devices. When the PMP ECU has been recognized, it appears in the "MY DEVICES" list as PMP. Click on "PMP" and wait for the smartphone to connect. When connected, the PMP shows "Connected". Now the PMP is connected to the phone and in the V4-MP App you should note the motorcycle data transmission



After the first connection the system connects automatically to the instrument panel (key ON).

ANDROID OPERATING SYSTEM

- Turn the ignition switch of the motorcycle ON with the PMP ECU correctly connected.
- Open the App's "settings" by clicking on the icon.

NOTE

THE ICON CAN VARY FROM ONE TO ANOTHER ANDROID VERSION

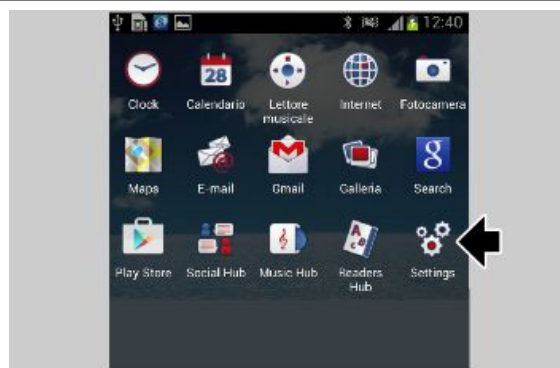

- In the page settings click on the "Bluetooth" menu.



- Inside the "BlueTooth" page if BlueTooth is not active, proceed to activate it by pressing the button indicated by the arrow BlueTooth active -> green button. Wait for the smartphone to recognize the PMP ECU until you see PMP in "Available devices" list.

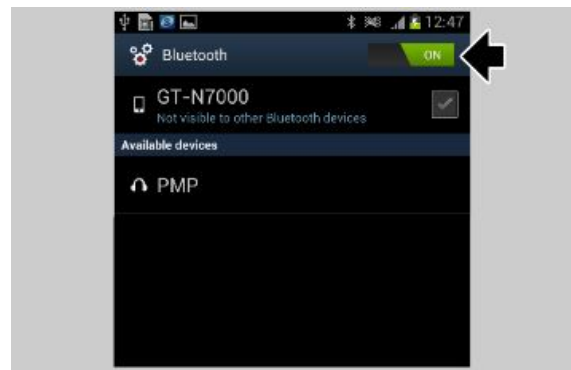

- When the PMP is found, click on the «PMP» line and make sure the smartphone is connected. Once connected, the PMP is added to the «Paired devices» list and in the menu PMP appears the message "Paired". Now the PMP is connected to the phone and in the V4-MP App you should note the motorcycle data transmission.



After the first connection the system connects automatically to the instrument panel (key ON).

Once the connection is established you can start the application by selecting the corresponding icon

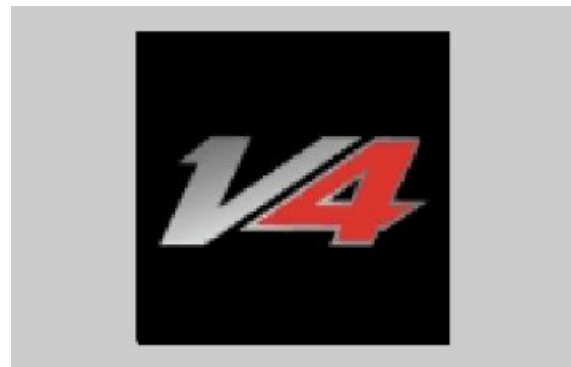

By turning off the instrument panel (key OFF) the application automatically closes

CAUTION

TO MAINTAIN A SUCCESSFUL CONNECTION IT IS ESSENTIAL THAT THE KEY SWITCH IS IN THE "ON" POSITION BEFORE THE APP IS LAUNCHED

CAUTION

AFTER THE KEY IS OFF IT WILL BE NECESSARY TO WAIT FOR ABOUT 20 SECONDS TO ENSURE THAT THE WIRELESS CONNECTION IS CLOSED.

IN CASE OF CONNECTION FAILURE JUST EXIT THE APPLICATION USING THE APPROPRIATE BUTTON, CLOSE IT FROM THE BACKGROUND MENU AND MANUALLY RESTART IT.

IF THE PREVIOUS DEVICE IS NOT IN THE AREA, AFTER 20 SECONDS THE SYSTEM WILL BE AVAILABLE TO CONNECT WITH A NEW SMARTPHONE.

INDEX OF TOPICS

ENGINE FROM VEHICLE

ENG VE

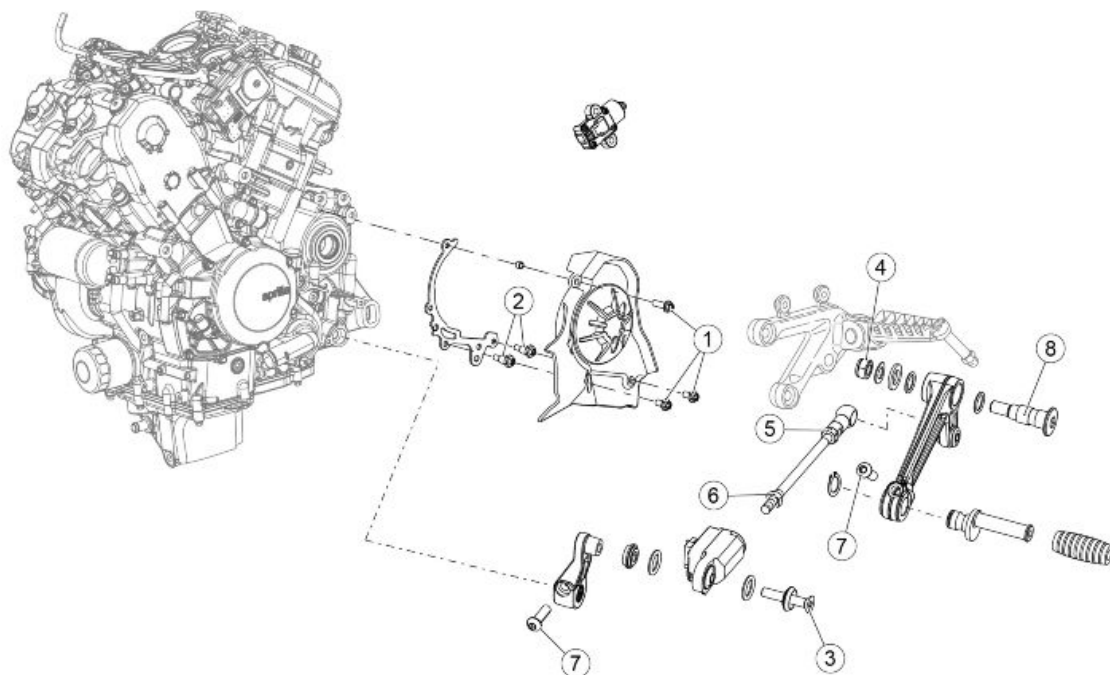

GEAR LEVER

Pos.	Description	Type	Quantity	Torque	Notes
1	Pinion protection guard fastening screws	M6	3	6 Nm (4.43 lb ft)	-
2	Threaded spacer	-	2	8 Nm (5.90 lb ft)	-
3	Countersunk, flat head, hex. socket screws	M6x35	1	10 Nm (7.38 lb ft)	Loct.
4	Self-locking nut	M8	1	25 Nm (18.44 lb ft)	-
5	Fastening between gear change tie-rod joint and gear change lever	-	1	8 Nm (5.90 lb ft)	Loct.
6	Nut used to fasten the gearbox tie-rod to the quick shift device	-	1	8 Nm (5.90 lb ft)	-
7	Gearbox lever fixing screws	M6	2	8 Nm (5.90 lb ft)	-
8	Pin for fastening the gear change lever to the footrest support	M8	1	25 Nm (18.44 lb ft)	-

- Apply water-repellent grease between the O-rings and the Quick Shift uniball

NOTE

ONCE ASSEMBLE, THE DISTANCE BETWEEN THE UNIBALL AND THE JOINT MUST BE APPROXIMATELY 180mm (7.09in).

Vehicle preparation

To remove the engine from the chassis, previously perform the following operations:

- Remove the fuel tank and the battery.
- Remove the fairing, the side fairings, the air deflectors and the fairing lug

Position the vehicle as described:

- Fasten an appropriately sized belt for the weight of the vehicle to the semi-handlebars and to a hoist.
- Place the rear stand.

Removing the engine from the vehicle

- Move the clamps (4) and disconnect the water pipe with the connector from the engine in order to empty the system

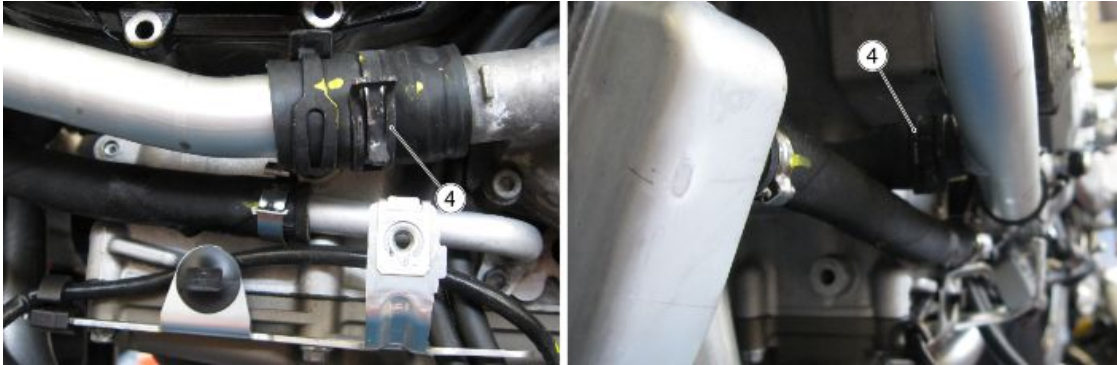

- Move the clamp (5) and disconnect the water pipe from the radiator fluid tank



- Disconnect the connectors (6) of the electric fans



- Use a container of suitable capacity, remove the clamp (7) and disconnect the oil connection pipe

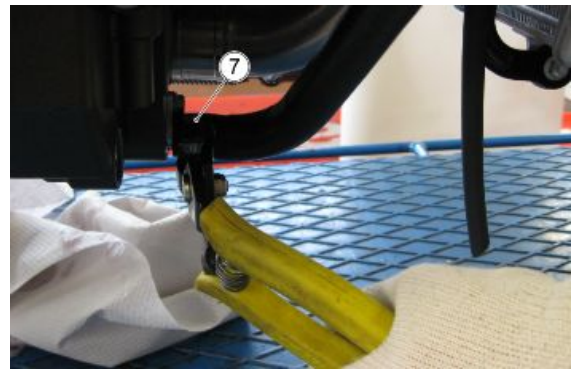

- Remove the clamp (8) fixing the oil pressure bulb wiring and exhaust valve to the water pipe



- Remove the fixing screws (9) of the radiators support bracket

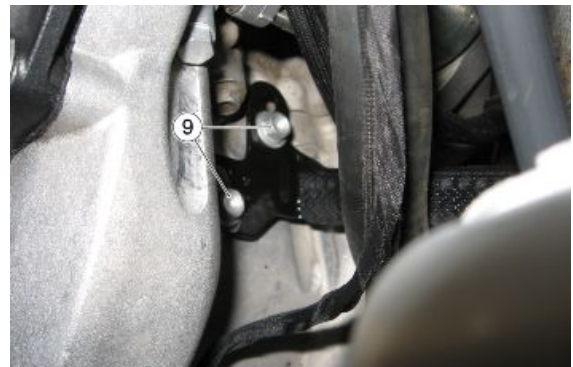

- Operating from both sides of the motorcycle, remove the screws (10) fixing the radiator to the support bracket



- Remove the radiators by sliding them off from the right side of the motorcycle

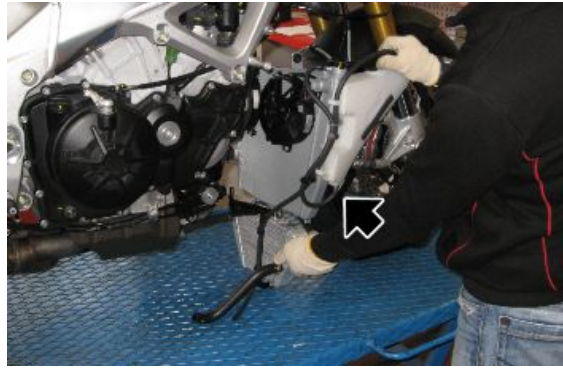

- Loosen the screw (11) and ease off the gear lever



- Remove the three fixing screws (12) of the pinion cover (13)

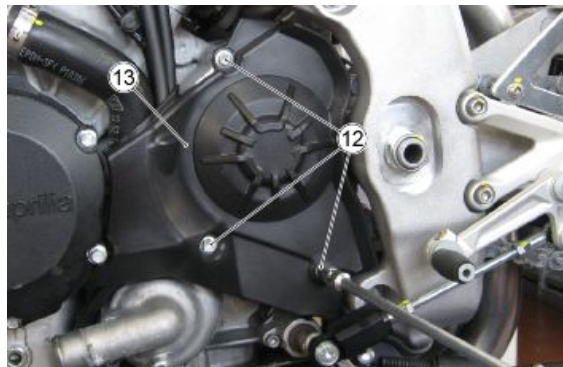

- Remove the fixing screw (14) of the cable grommet (15)

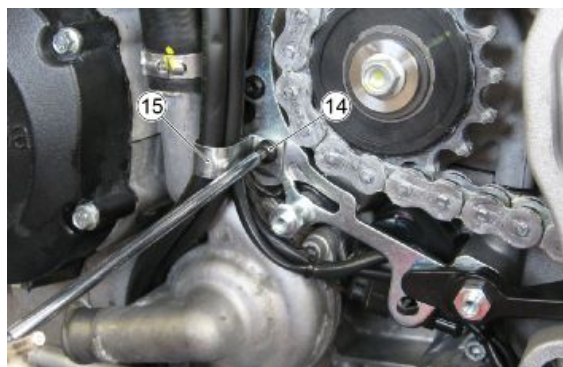

- Remove the fixing screw (16) and slide off the chain slider (17)



- Remove the fixing screw (18) of the chain guide plate (19)

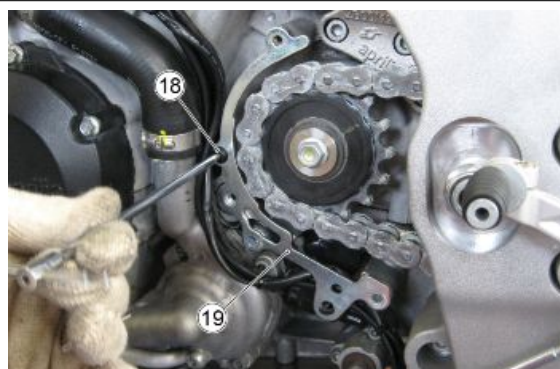

- Cut the two clamps (20) that connect the wiring of the quick-shift to the wiring of the side stand and of the lambda probe

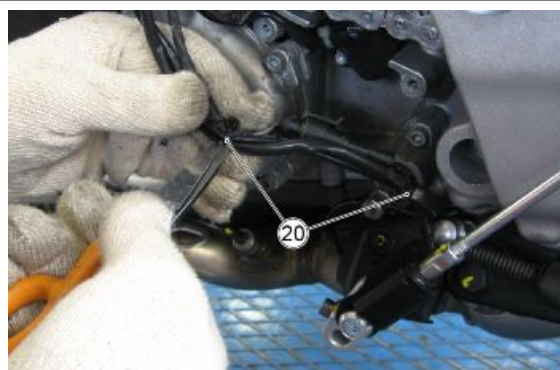

- Disconnect the connector (21) of the quick-shift and release the wiring



- Remove the two fixing screws (22) of the footrest complete with leverage

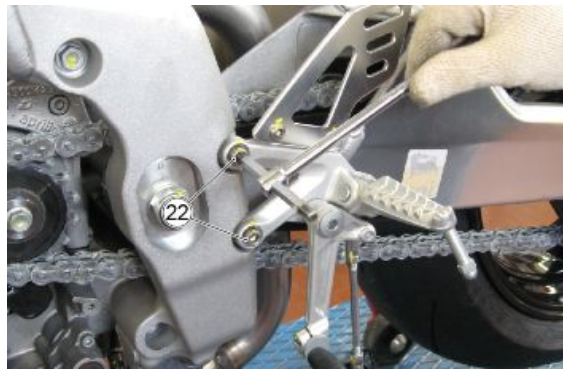

- Disconnect the connector (23) of the side stand sensor and release the wiring



- Undo the two fixing screws and remove side stand (24)



- Disconnect the connectors of the lambda probes (25)



- Loosen the nut (26) of the rear wheel pin



- Working from both sides of the motorcycle, loosen the locknuts (27) and act on the register screws (28) to loose the chain tension



- Loose the clamp (32) that blocks the silencer at the central manifold



- Detach and remove the springs (29) fixing the front exhaust manifolds



- Remove the four screws (30) fixing the manifolds to the front heads



- Remove the two front manifolds (31)



- Loose the clamp (32) that blocks the silencer at the central manifold



- Remove the screw (33) and the nut locking the silencer at the rider footrest



- Slide off the central manifold and remove the silencer

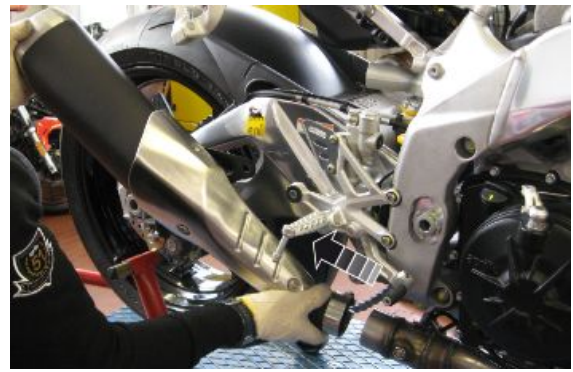

- Remove the fixing clamp (34) of the exhaust valve wiring

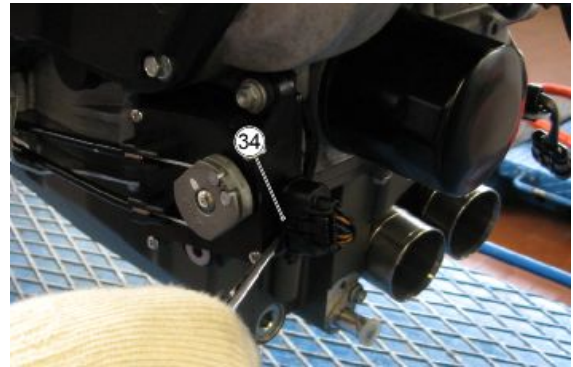

- Disconnect the connector (35) of the exhaust valve

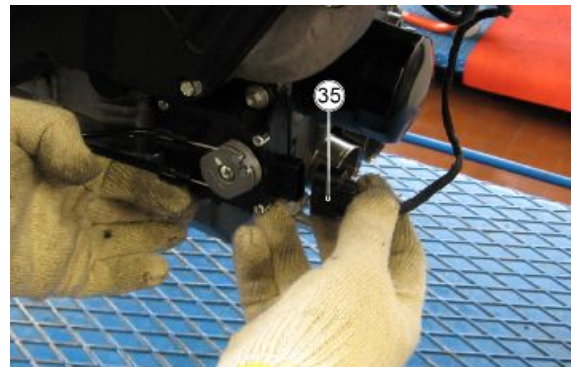

- Disconnect the connector (35) of the exhaust valve

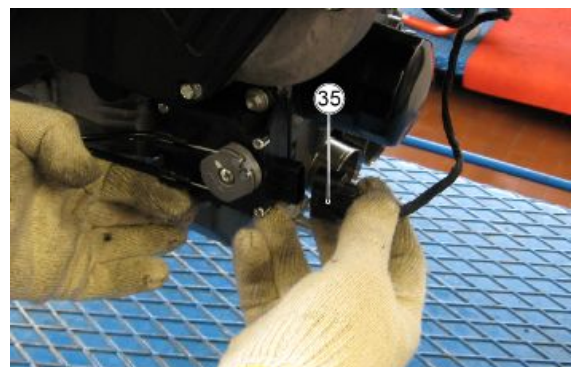

- Remove the fixing screws (36) of the exhaust valve

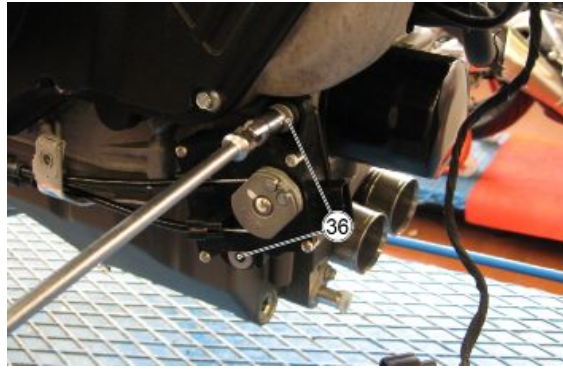

- Detach and remove the springs (37) fixing the rear exhaust manifolds

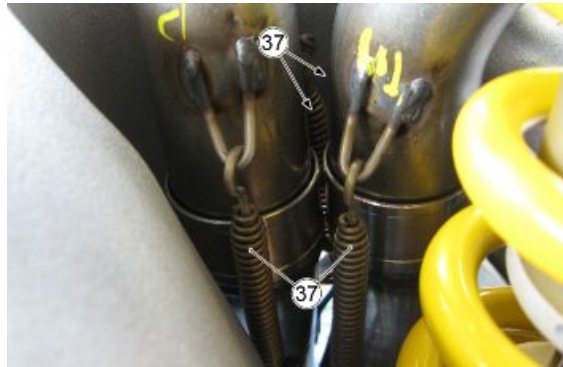

- Remove the central exhaust manifold (38)



- Remove the four fixing screws (39) of the rear exhaust manifolds



- Remove the rear exhaust manifolds (40)



- Detach the clutch cable (41), remove the nut (42) and take the cable complete with sheath (43) off from the guide in the housing

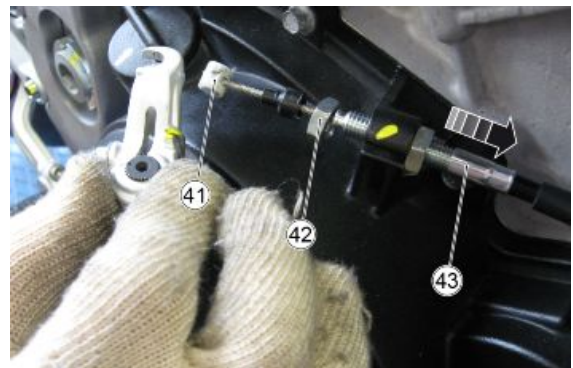

- Remove the rubber cap (44)
- Unscrew and remove the nut (45) and collect the washer
- Remove the power supply cable from the starter motor.



- Remove the engine oil pressure sensor (46)

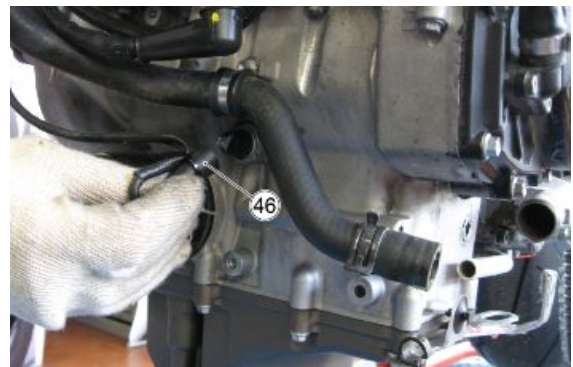

- Undo and remove the screw (47) and release the ground cables



- Detach the ground cable and unscrew and remove the nut (48)



- Disconnect the engine wiring connector (49)



- Remove the clamp (50) that locks the main wiring at the ABS system pipes



- Remove the screws (51) to remove the ABS protection plate

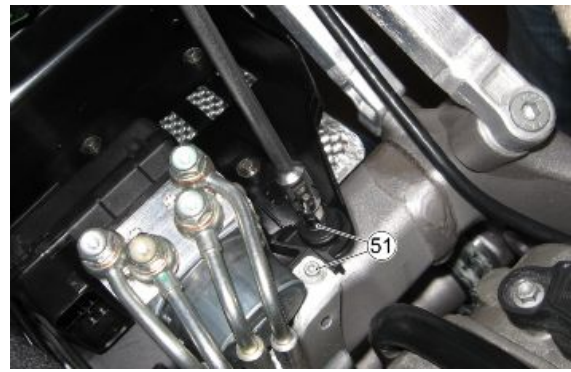

- Remove the protection plate (52) of the ABS system



- Install the engine support and place a winch under it

Specific tooling

020864Y Engine mounting plate

- Operating from the right side of the motorcycle, remove the upper screw (53) fixing the engine to the chassis

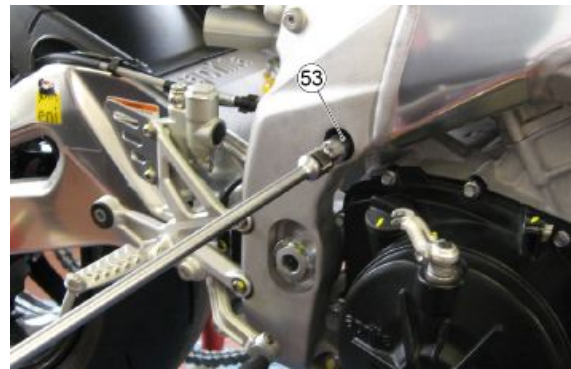

- Completely unscrew the internal upper bush (54)



- Remove the lower screw (55) fixing the engine to the chassis



- Completely unscrew the internal lower bush (56)



Installing the engine to the vehicle

- Before aligning the engine retainers, place on the frame the internal and external right and left inserts, with the precautions described below.

Adjustment of engine height relative to the chassis is determined by properly inserts placed on the chassis (front position) and on the engine, matching the fixing points of the engine to the chassis.

The hole position relative to the centreline of the insert is $e=-5$ mm ($e=-0.197$ in), therefore, the engine is fixed at minimum height possible.

CAUTION

THE LEFT AND RIGHT FRONT INSERTS ARE EQUAL AND MUST NOT BE PLACED IN THE INVERTED POSITION.

Adjustment of engine height relative to the chassis is assured by properly inserts placed on the chassis (front position) and on the engine, matching the fixing points of the engine to the chassis.

The hole position relative to the centreline of the insert is $e=-5$ mm ($e=-0.197$ in), therefore, the engine is fixed at minimum height possible.

CAUTION

THE LEFT AND RIGHT FRONT INSERTS ARE EQUAL AND MUST NOT BE PLACED IN THE INVERTED POSITION.

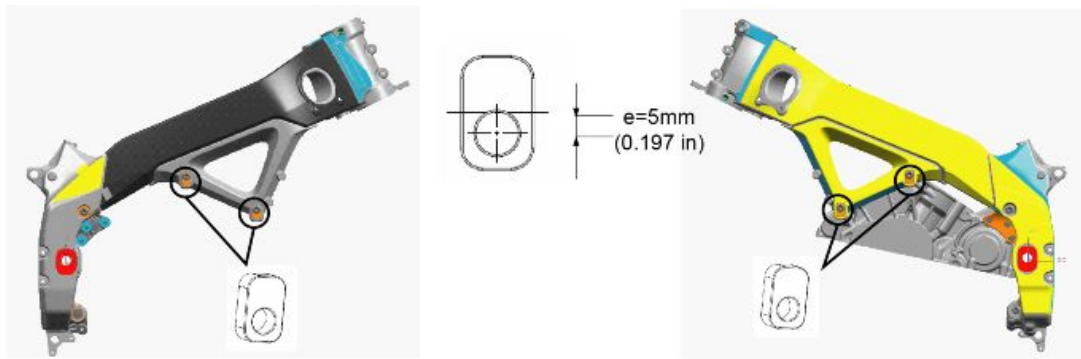

The height of the swingarm pin relative to the chassis is adjusted with special inserts installed in the respective seats in the chassis. The hole is offset by -2.5 mm (- 0.098 in) relative to the centreline of the insert, as a result the swingarm is in the low position.

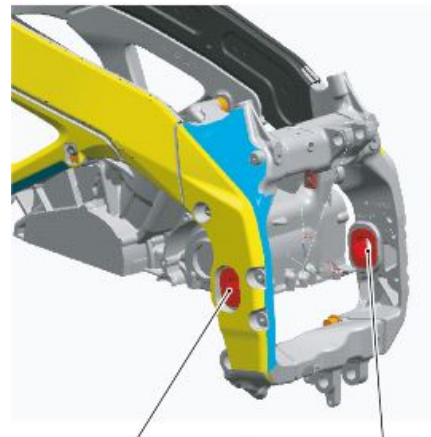

There are 4 inserts, subdivided as follows:

- Inner/outer
- Right/Left

The two right side swingarm pin inserts are different.

The two left side swingarm pin inserts are the same.

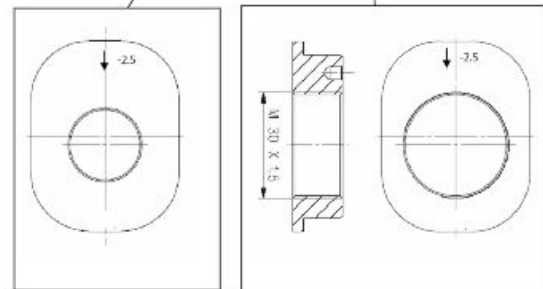

CAUTION



THE FOUR INSERTS MUST BE FITTED WITH THE ARROW FACING DOWNWARDS, OTHERWISE THE VEHICLE WILL BE DAMAGED!

CAUTION

THE RIGHT REAR INSERTS (-5mm (-0.19 in)) AND THE LOWER LEFT REAR INSERT (-5mm (-0.19 in)), ARE EQUAL.

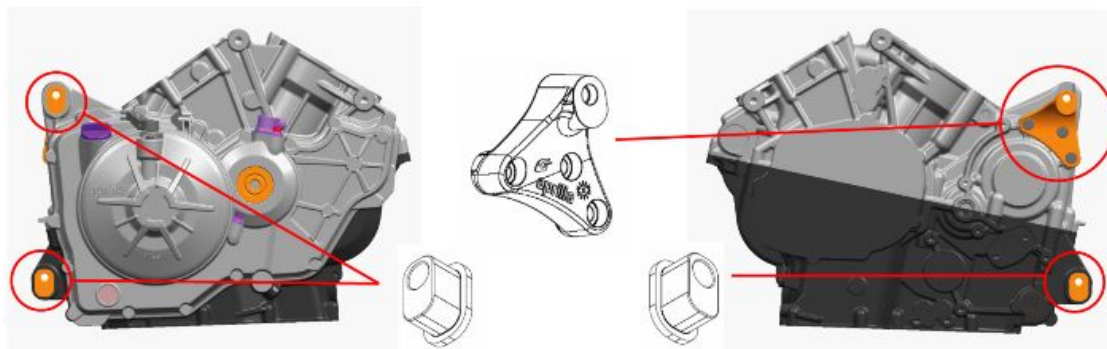

- Working from the vehicle left side, install the left upper engine attachment, tightening the three screws.



- With the help of a second operator, secure the vehicle chassis with a hoist and onto a front and rear stand and lift the engine to place it in position.

Specific tooling

020864Y Engine mounting plate

Centring the engine on the chassis

CAUTION

PAY SPECIAL ATTENTION DURING CENTRING PHASE OF THE ENGINE ON THE CHASSIS. OPERATE WITH CAUTION SO AS NOT TO DAMAGE THE SCREWS AND THE CHASSIS INTERNAL AND EXTERNAL SPACERS.

Working on the left side, place and screw without tighten:

- the two front fixing screws (1);
- the engine attachment upper fixing screw (6);
- the lower rear fixing pin (3), so as to centre the engine position.

Working on the right side, place and screw without tighten:

- the two front fixing screws (2) and, from the chassis internal side, the specific spacers (4);
- the upper rear fixing screws (5).

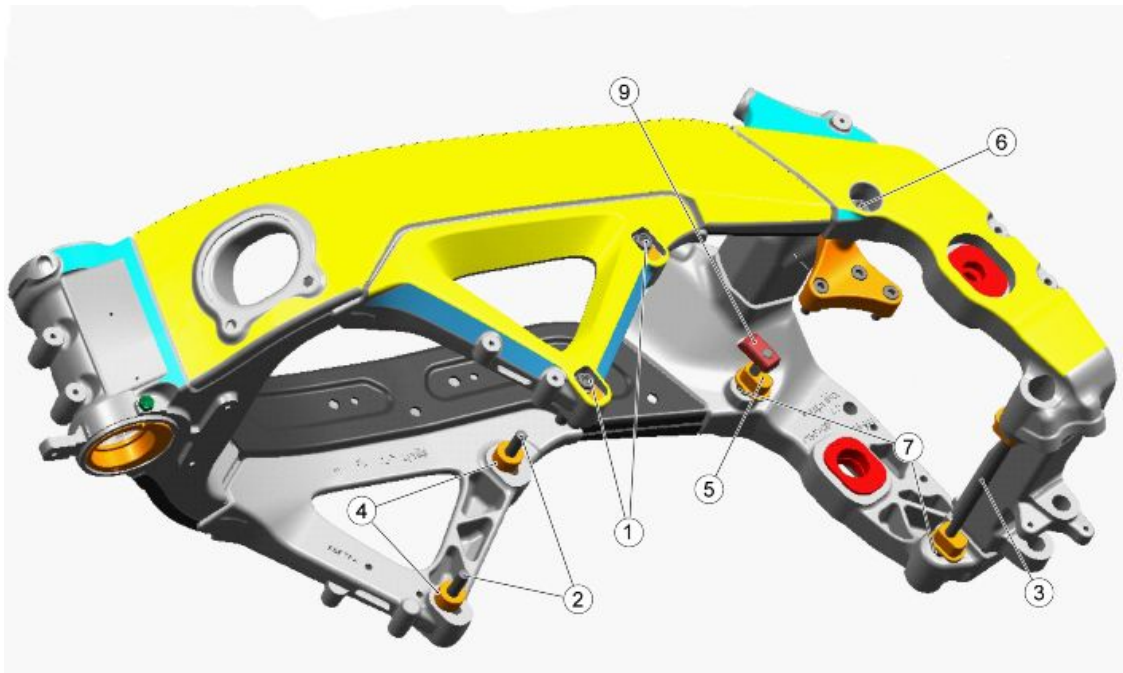

Engine retainer

CAUTION

AFTER ENGINE ALIGNMENT AND CENTRING ON THE CHASSIS, ASSURE THE CORRECT POSITION BEFORE TIGHTENING TO THE PRESCRIBED TORQUE ALL THE SCREWS IN THE ABOVE MENTIONED ORDER.

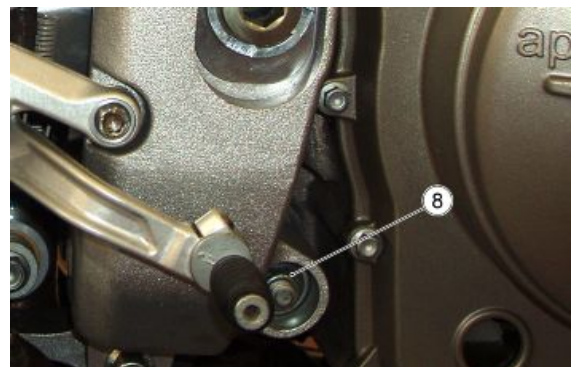

Working on the left side:

- tighten the two front screws (1) to the prescribed torque.
- Tighten the engine attachment upper fixing screw (6) to the prescribed torque, after placing the corresponding washer.
- Slide the lower rear fixing pin (3);

Working on the right side:

- slide the upper rear fixing screw (5).
- Place and tighten internally the two set pack bushings (7) to the prescribed torque.
- Place again on the left side, the lower rear fixing pin (3).
- Tighten the rear pin fastening nut (8).
- Place again the upper rear fixing screw (5) and tighten the lock nut (9) on the internal side of the chassis to the prescribed torque.
- Tighten the two engine screws (2) to the prescribed torque.

- Refit the clamps on the saddle mounting.



- Place the radiator frame, the washer and tighten the screw, fastening the frame to the engine.



- Place the gear lever and tighten the screw.



- Position the quick-shift cable harness and fasten using ties.

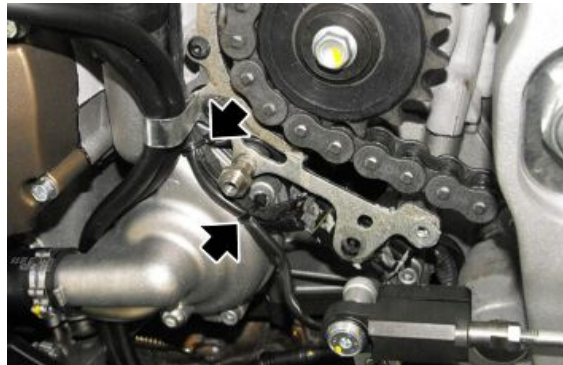

- Connect the quick-shift connector.

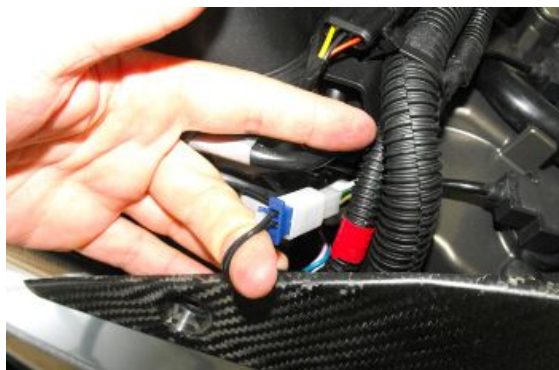

- Connect the alternator connector.



- Connect the voltage regulator connector.



- Position and fix the hand grip position sensor to the chassis.

WARNING

BEFORE POSITIONING THE DEMAND SENSOR APPLY SOME LOCTITE 243 ON THE SILENT BLOCKS.



- Connect the neutral sensor.



- Place the two fuel breather pipes.
- Install the side stand.

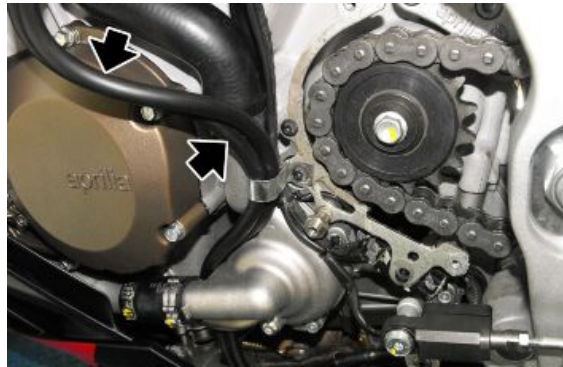

- Place the pinion and insert the transmission chain in the seat.
- Tighten the rear wheel fixing nut.



- Adjust the drive chain adjuster screws.



- Place the two washers and tighten the pinion fixing screw.

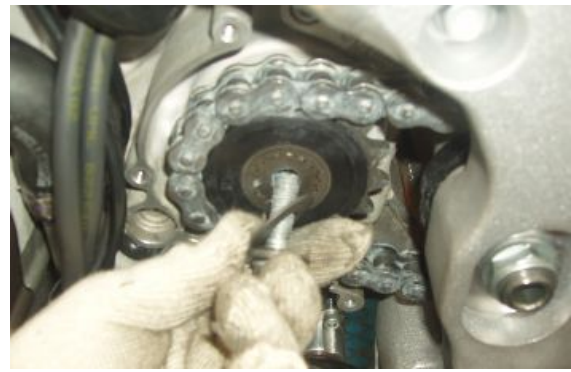

- Place the pinion cover and tighten the three screws.

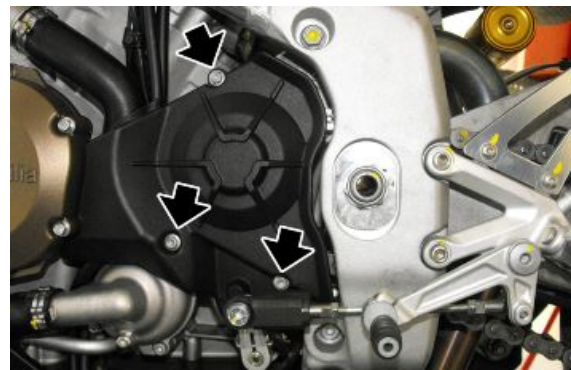

- Connect the vehicle cable harness / engine cable harness connector.



- Working on the right side of the vehicle, connect the exhaust valve control unit connector.



- Place the ground on the frame.
- Fit the washer and tighten the nut.



- Place the cable grommet and the three cable leads as shown.
- Tighten the cable grommet fixing screw.

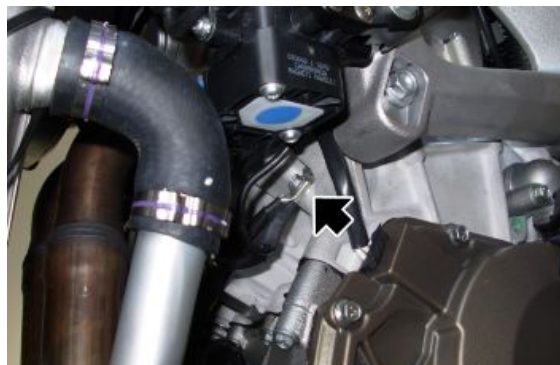

- Connect the starter motor, place the washer and tighten the nut.
- Place the rubber cap.



- Tighten the engine oil pressure sensor.



- Connect the timing sensor.



- Connect the clutch cable.



- Check and adjust the clutch lever clearance with the adjuster screw.
- The clutch lever clearance should be between 1-3 mm (0.039 - 0.12 in).

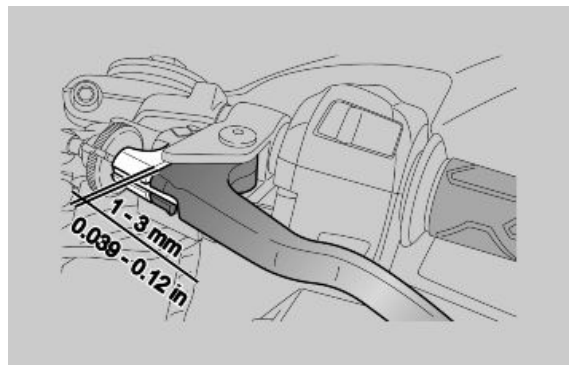

INDEX OF TOPICS

ENGINE

ENG

**key:**

1. rear left cylinder;
2. front left cylinder;
3. rear right cylinder;
4. front right cylinder.

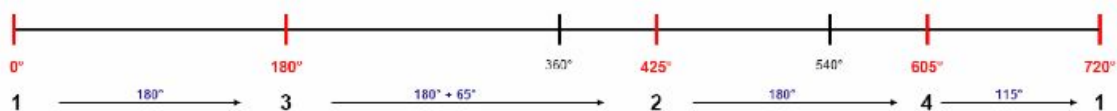
**Combustion sequence:**

1 - 3 - 2 - 4

Combustion angle:

cyl 1: 0°

cyl 2: 180°

cyl 3: 425°

cyl 4: 605°

Gearbox

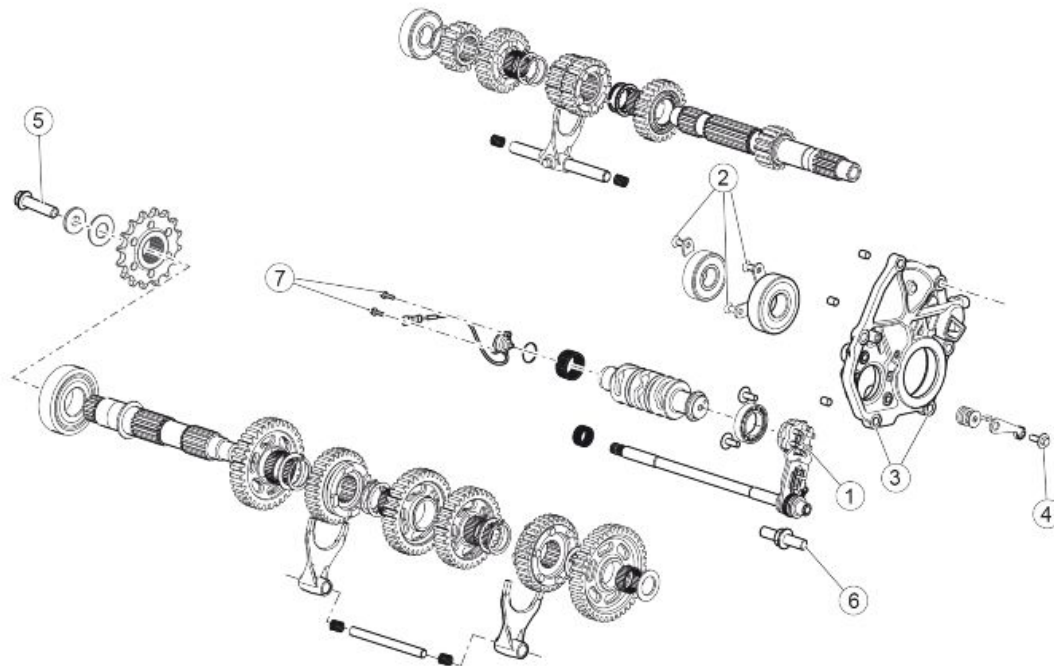

GEARBOX

Pos.	Description	Type	Quantity	Torque	Notes
1	"Philips" cylindrical head hex. socket screw	M6x20	1	10 Nm (7.38 lb ft)	Loct. 243
2	Hex. socket flat head counter sunk screw for fastening the bearing retaining plates	M6x16	3	10 Nm (7.38 lb ft)	Loct. 243
3	Flanged, hex. head flange retaining screws	M8x25	6	25 Nm (18.44 lb ft)	-
4	Special screw with index lever fastening collar	M6	1	10 Nm (7.38 lb ft)	Loct. 243
5	Pinion fastening	-	1	50 Nm (36.88 lb ft)	Loct. 243
6	Pre-selector retaining screw on crankcase	-	1	25 Nm (18.44 lb ft)	Pre-impregnated screw in absence of 3M 2353
7	Flanged, hex. head gear indicator fastening screws	M5x15	2	6 Nm (4.43 lb ft)	-

Removing the gearbox

- Remove the gearbox selector.
- Remove the clutch housing.
- Remove the gear sensor from the flywheel side.

- Remove the Seeger ring.
- Remove the water/oil pump control gear.

**See also**

[Removing the gear selector](#)
[Disassembling the clutch](#)

- Remove the water/oil pump control gear driving pin



- Loosen the screw.



- Unscrew and remove the six screws.

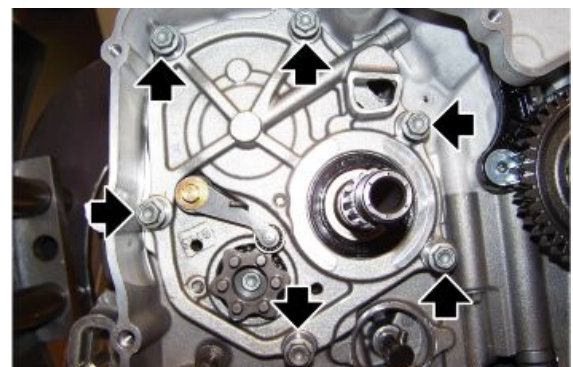

- Screw a M10x120 screw in the secondary shaft hole, from the alternator side, to make it easier to extract the gearbox unit.
- Use a rubber mallet to tap on the secondary shaft from the alternator side to detach the gearbox cover from the crankcase.
- Remove the complete gearbox unit.



Gearbox shafts

Disassembling the gearbox

Based on the design development of the engine, some gear components can have superficial treatments of different types.

Some components of the gear can have a superficial cover in **WC/C**.

This coating consists of a layer composed of tungsten carbide lamellae alternating with amorphous carbon lamellae. The coating **WC/C** has an elevated hardness and a good resistance to wear. The main reason for using this coating is its extremely low friction coefficient, making this an ideal treatment for preventing adhesion phenomena such as seizing and cold welding. The treatment has a characteristic colouring, darker than at a traditional operation.

- Only some components have the coating WC/C, among them:
 1. Primary shaft
 2. the gear of 3a-4a of the primary shaft;
 3. All forks

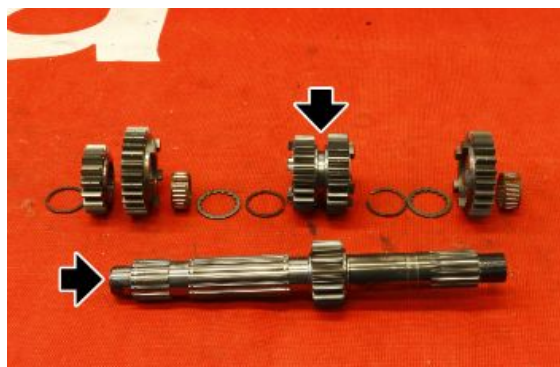

GEAR REMOVAL

- Position the gear in neutral, checking that when the primary shaft rotates the secondary shaft does not move.
- Remove the gearbox unit.
- Slide off the gearbox primary shaft control rod (1)



- Remove the fork (2) of the gearbox primary shaft



- Slide off the gearbox secondary shaft control rod (3)



- Remove the forks (4) of the gearbox secondary shaft

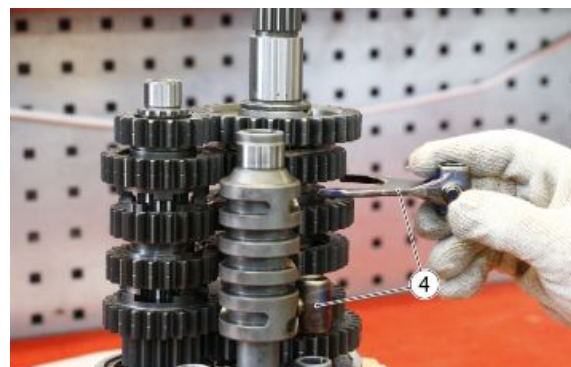

- Remove both gearbox shafts from the cover



- Remove the shim washer (5) that is located on the secondary shaft between the shaft and the cover



- Loosen and remove the screw (6)

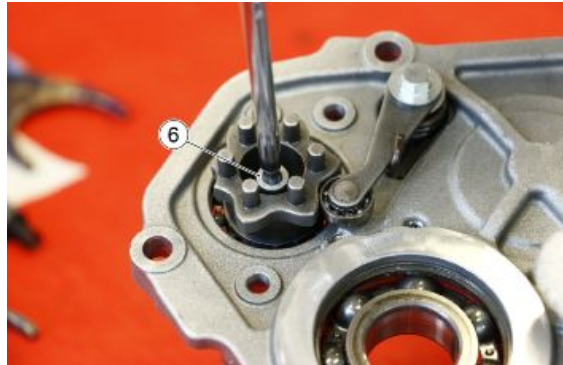

- Remove the desmodromic shaft (7)



- Remove the selector drum (8)



DESMODROMIC GEARBOX CONTROL ROD DRUM ROLLER CAGE, ALTERNATOR SIDE

- Remove the lower crankcase.
- A suitable extractor must be used to remove the desmodromic gearbox control rod drum roller cage from the alternator side.

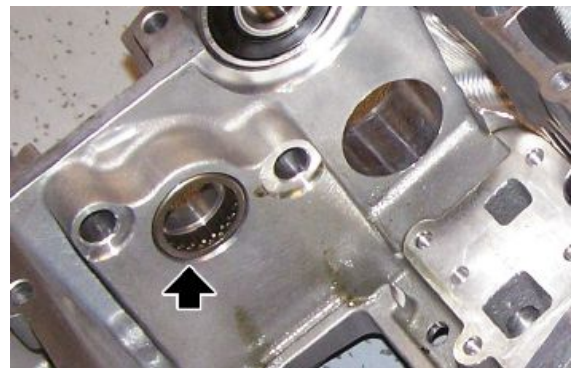

- A specific punch is required to install the desmodromic gearbox control rod drum roller cage.
- Lubricate the seat and insert the new roller cage.

Specific tooling

020863Y Punch assembly cage with rollers desmodromic drum.....



Checking the primary shaft

Characteristic

Maximum wear limit for the selection gear grooves

5.3 mm (0.21 in)

Minimum wear limit of the pinion side primary shaft seat

24.97 mm (0.98 in)

Minimum wear limit of the clutch side primary and secondary shaft seat

19.97 mm (0.79 in)



Checking the secondary shaft

Characteristic

Maximum wear limit for the selection gear grooves

5.3 mm (0.21 in)

Minimum wear limit of the pinion side secondary shaft seat

29.97 mm (1.18 in)

Minimum wear limit of the clutch side primary and secondary shaft seat

19.97 mm (0.79 in)

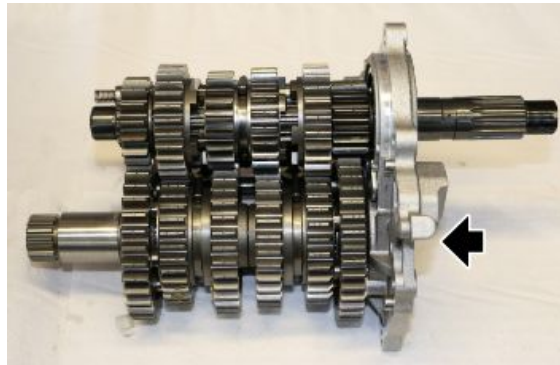

Checking the desmodromic drum

Check gear drum for damage, scratches and wear and replace the desmodromic if necessary.

Check the desmodromic segment (1) for damage and wear and replace it if necessary.

Check the desmodromic bearing (2) for damage and pitting and replace it if necessary.



Characteristic

Maximum selector shaft eccentricity

0.2 mm (0.0079 in)

Checking the forks

The purpose of the springs at the end of the gearbox control rods is to reduce vibration and make it easier to engage the gears.

Characteristic

Maximum selection fork axial clearance

0.05 mm (0.0020 in)

Minimum wear limit of the selection fork guide pins

6.8 mm (0.27 in)

Maximum eccentricity of the two fork guide shafts

0.05 mm (0.0020 in)

NOTE

THE FOLLOWING PROCEDURE IS VALID FOR ALL GEARBOX FORKS.

- Check the transmission fork cam roller «1» and the transmission fork tooth «2» for damage, deformation and wear.
- Replace the transmission fork if necessary.



- Check the transmission fork movement and if it is not regular, replace the transmission forks.

Assembling the gearbox

- Place the drum (1) of the gear selector on the support and insert the desmodromic shaft (2), paying attention to correspond the operations on both components

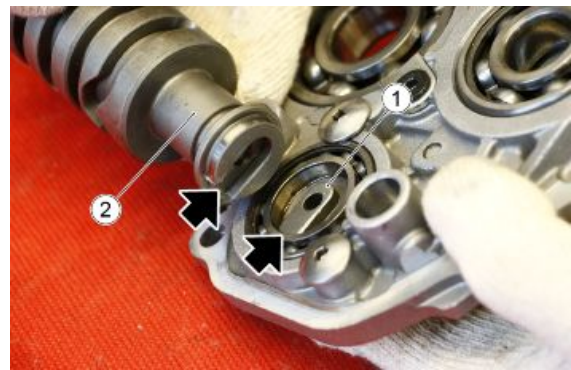

- Position and tighten the screw (3) fixing the drum to the desmodromic shaft

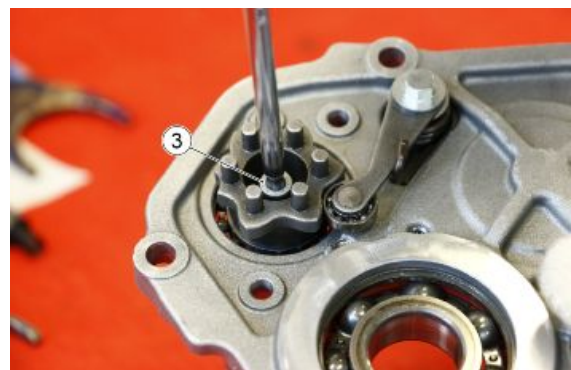

CAUTION



SECURE THE SHIM WASHER (4) TO THE SECONDARY SHAFT WITH GREASE



- Move the gearbox shafts together and fit them into the support



- Grease the sliding bushes of the forks

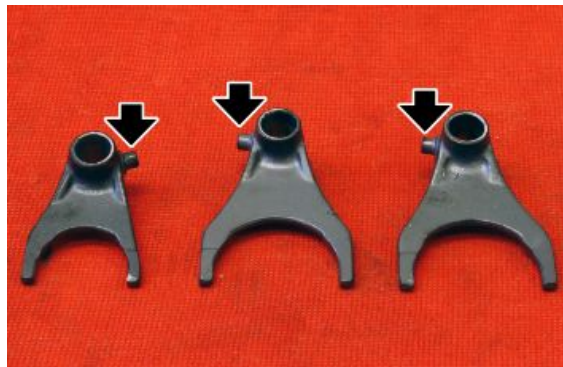

- Insert the forks (5) in the specific seats of the gearbox secondary shaft



- Insert the gearbox secondary shaft control rod (6) checking the presence of the springs



- Insert the fork (7) in the specific seat of the gearbox primary shaft



- Insert the gearbox primary shaft control rod (8)



- Position the special tool from the alternator side in order to not ruin the edges of the oil seal.
- Insert the gearbox unit in the crank-case.



Specific tooling

0277308 Guide bushing for gearbox secondary shaft



- Remove the special tool from the alternator side.
- Tighten the six screws that fasten the gearbox unit to the crankcase.

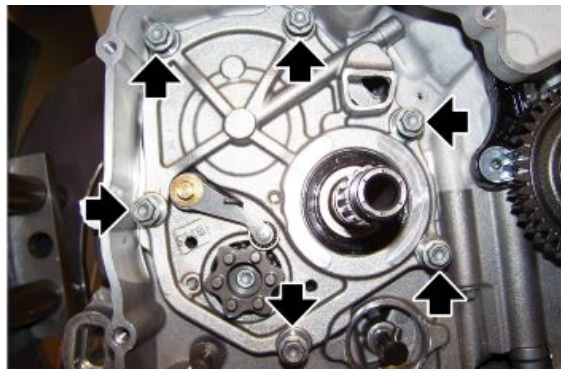

Specific tooling

0277308 Guide bushing for gearbox secondary shaft

- Insert the driving pin on the oil pump shaft.
- Install the water/oil pump control gear.
- Insert the Seeger ring.
- Install the gear sensor, making the pin coincide with the slot on the desmodromic control rod.



Gear selector

Removing the gear selector

- Drain the engine oil.
- Remove the clutch cover.
- Working from the clutch side, remove the selector control shaft.



- Remove the gear locking pawl and retrieve the washer and the spring.

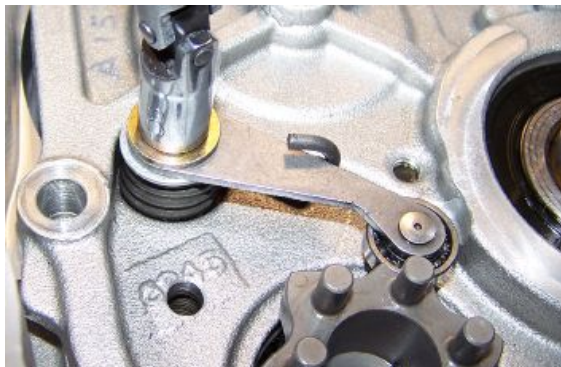

GEARBOX CONTROL ROD ROLLER CAGE, CLUTCH SIDE

- Remove the lower crankcase.
- The specific tool without an adaptor must be used to remove the gearbox control rod roller cage from the clutch side.



Specific tooling

020862Y Punch assembly cage with rollers gearbox control rod.....

- Fit the adaptor on the specific tool to insert the roller cage at the controlled depth.
- Lubricate the seat and insert the new roller cage from the clutch side.



Specific tooling

020862Y Punch assembly cage with rollers gearbox control rod.....

GEARBOX CONTROL ROD OIL SEAL AND ROLLER CAGE, SPACER

- Remove the gearbox control rod spacer.
- Remove the oil seal and the roller cage.
- Install a new gearbox control rod roller cage on the spacer, using the specific tool without an adaptor.

Specific tooling

020862Y Punch assembly cage with rollers gearbox control rod.....

- Position a new oil seal on the spacer with the writing on the edge of the oil seal facing outward.
- Install the oil seal on the spacer using the specific tool without an adaptor.



Specific tooling

020862Y Punch assembly cage with rollers gearbox control rod.....

Checking the gear selector

Check the stop lever for damage and wear and make sure the ball rotates freely.

If necessary, replace the parts.

Check the gear selector spring for damage and wear.

If necessary, replace the part.



Check the selector shaft and its teeth for damage and wear.

If necessary, replace the part.

Check the lever spring for damage and wear.

If necessary, replace the part.



Reassembling the gear selector

- To refit, lubricate and carry out the removal operations but in reverse order.

Starter motor

Removing the starter motor

- Undo the fixing screws (1) of the starter motor, collecting the spacers (2)



- Remove the starter motor (3) from its housing.



Removing the idle gear

- Remove the clutch cover.
- Remove the intermediate gear.



Start-up system check



IF THE DUAL STARTER GEAR TOOTHING IS DEFORMED AFTER STARTING, THE STARTER MOTOR TOOTHING MUST BE CHECKED AS WELL.

Check the dual starter gear tooting (1) and the freewheel gear (2) to see if the material is damaged or deformed.



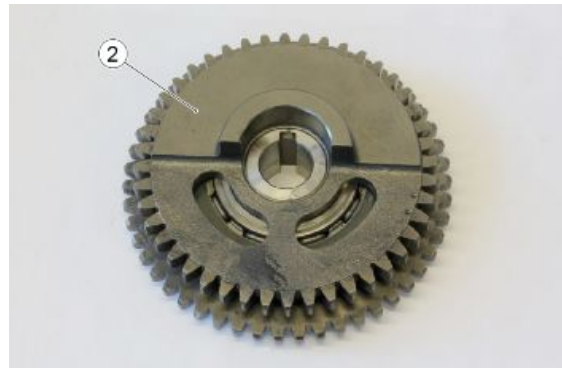

If deformations or broken material are found on the sliding surface, replace the freewheel gear (2). Check the freewheel sliding surface (2) for wear. Make sure that the woodruff key slot is in perfect condition.

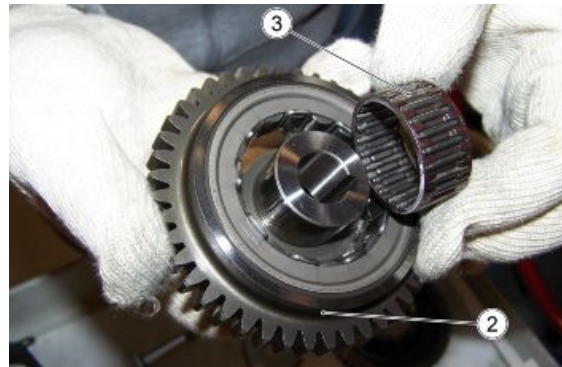

Remove the needle cage (3) and the roller cage (4) from their housings on the freewheel (2) and check the rollers/needles for wear. Check for wear on the freewheel sliding surface (2).

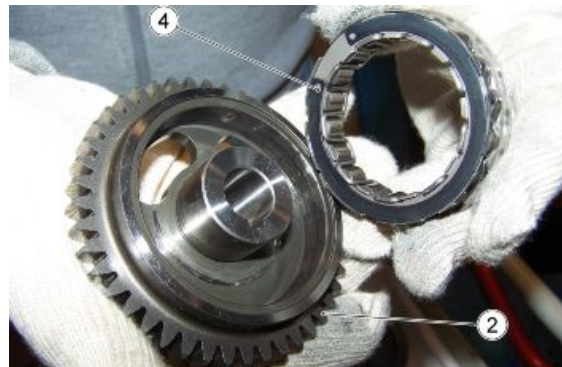

Fitting the idle gear

The ratios between the gears of the starter system are:

1. Starter motor 9 teeth;
2. External transmission gear 64 teeth;
3. Internal transmission gear 12 teeth;
4. Freewheel 49 teeth.

- Fit the intermediate gear.
- Fit the clutch cover.

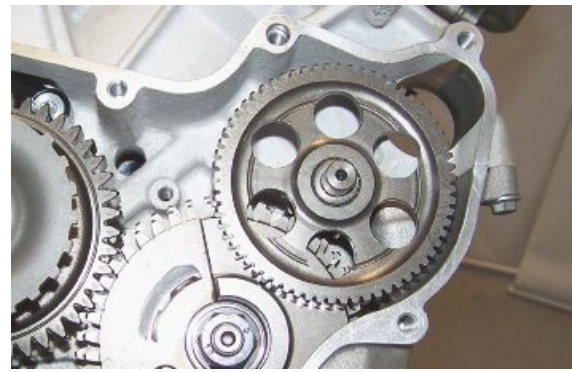

Generator side

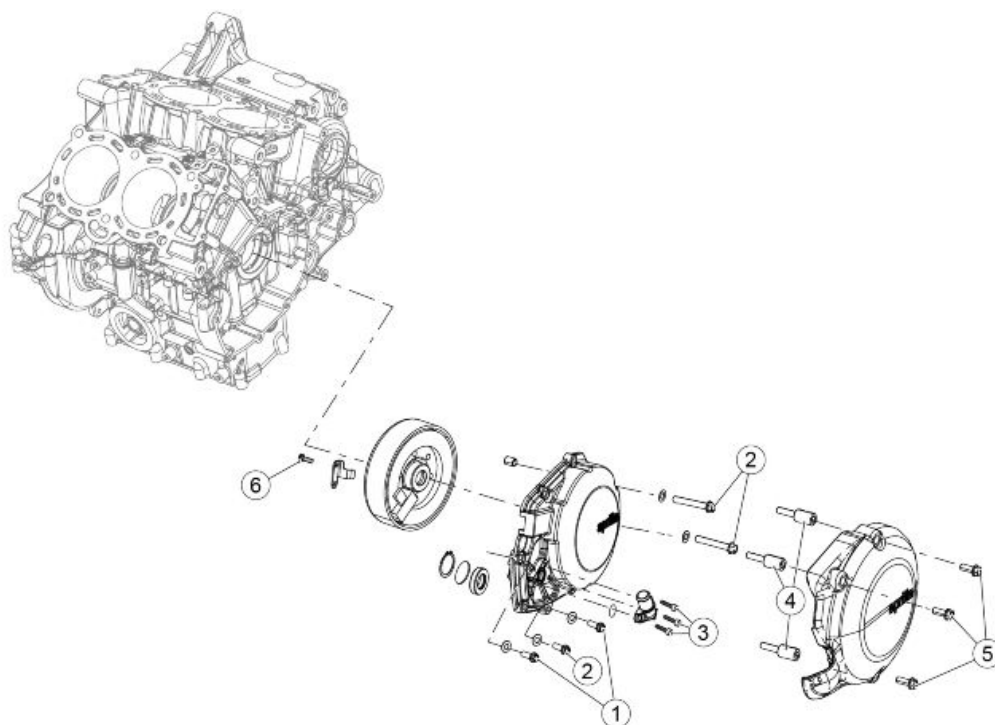

GENERATOR COVER

Pos.	Description	Type	Quantity	Torque	Notes
1	Cover fastening screws	M6x25	2	12 Nm (8.85 lb ft)	Tighten to torque, unscrew and re-tighten to torque.
2	Cover fastening screws	M6x40	3	12 Nm (8.85 lb ft)	Tighten to torque, unscrew and re-tighten to torque.
3	Blow-by coupling SHC fastening screws	M5x16	3	5 Nm (3.69 lb ft)	-
4	Spacers for soundproof cover	-	3	6 Nm (4.43 lb ft)	-
5	Soundproof cover fastening screws	M6	3	6 Nm (4.43 lb ft)	-
6	TE flanged screw fixing the cable tie plate	M5x12	1	6 Nm (4.43 lb ft)	Pre-impregnated screw and in absence Loct.2045
-	Stator SHC fixing screw	M6x30	1	10 Nm (7.38 lb ft)	Pre-impregnated screw and in absence Loct.2045

Removing the flywheel cover

- Unscrew and remove the three fastening screws (1) from the soundproofing cover (2).
- Remove the soundproofing cover (2).

- Release the clamp and detach the Blow-by pipe.
- Unscrew and remove the five screws (3) and the three special screws (4).
- Mark the screws (3) appropriately, as their lengths are different.
- Remove the cover (5) together with the stator and retrieve the two centring dowels.



Magneto flywheel removal

- Remove the flywheel cover.
- Block flywheel rotation using the specific tool.
- Unscrew and remove the screw.

Specific tooling

020914Y Flywheel retainer



- Remove the tool for blocking flywheel rotation.
- Insert a SHC M10x20 screw into the crankshaft hole, which will act as a mounting base for flywheel extraction.
- Remove the flywheel using the specific extractor.
- Collect the SHC M10x20 screw.



Specific tooling

020913Y Flywheel extractor

See also

[Removing the flywheel cover](#)

Inspecting the cover components

- Unscrew and remove the three Blow-by system fitting screws.
- Remove the Blow-by system fitting.
- Replace the O-ring with a new one of the same type



-
- Remove the flywheel cover.
 - Remove the Seeger ring.



-
- Remove the shim washer.



-
- Remove the oil seal.

CAUTION

DURING REFITTING REPLACE THE OIL SEAL WITH A NEW ONE OF THE SAME TYPE.
SET THE NEW OIL SEAL WITH THE MARKING ON THE EDGE FACING OUTWARD.



Installing the flywheel

- Position the flywheel on the crankshaft.
- Block flywheel rotation using the specific tool.
- Tighten the screw.



Specific tooling

020914Y Flywheel retainer

Flywheel cover installation

- Insert the centring dowels in the cover.
- Apply a layer of sealing paste along the external edge of the cover.
- Insert the cover together with the stator.



Recommended products

Three bond Sealing paste

-

- Tighten the five screws (1) and the three special screws (2).
- Tighten the screws working in stages and diagonally.
- Insert the Blow-by system pipe and fasten it with a new clamp.

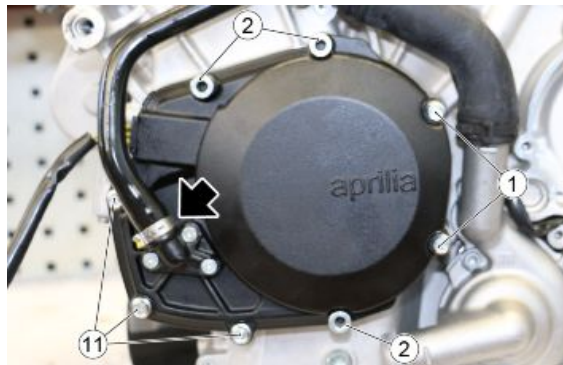

- Position the soundproofing cover and lock it in place using the three appropriate screws

Clutch side

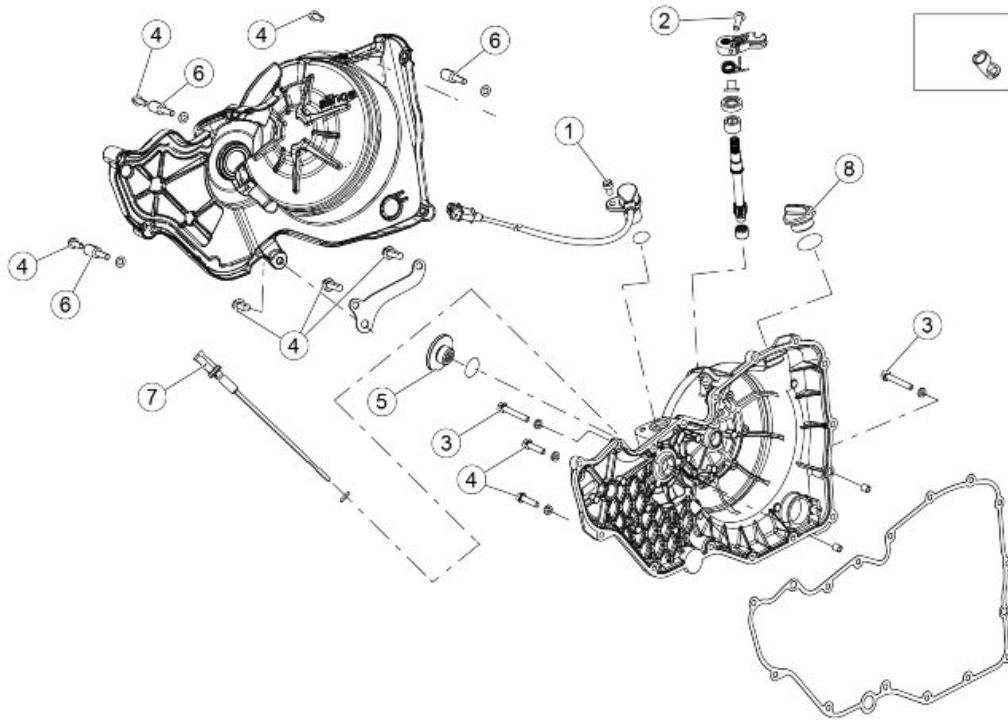

CLUTCH COVER

Pos.	Description	Type	Quantity	Torque	Notes
1	Rpm sensor fixing screw	-	1	8 Nm (5.90 lb ft)	-
2	TE Flanged screw	M6x20	1	10 Nm (7.38 lb ft)	-
3	TE Flanged screw	M6x35	2	12 Nm (8.85 lb ft)	Tighten to torque, unscrew and re-tighten to torque.
4	TE Flanged screw	M6x22	14	12 Nm (8.85 lb ft)	Tighten to torque, unscrew and re-tighten to torque.
5	Engine timing inspection cap	-	1	20 Nm (14.75 lb ft)	-
6	Spacers for soundproof cover	-	5	6 Nm (4.43 lb ft)	-
7	Oil level dipstick	-	1	3 Nm (2.21 lb ft)	-
8	Oil load cap	-	1	5 Nm (3.69 lb ft)	-

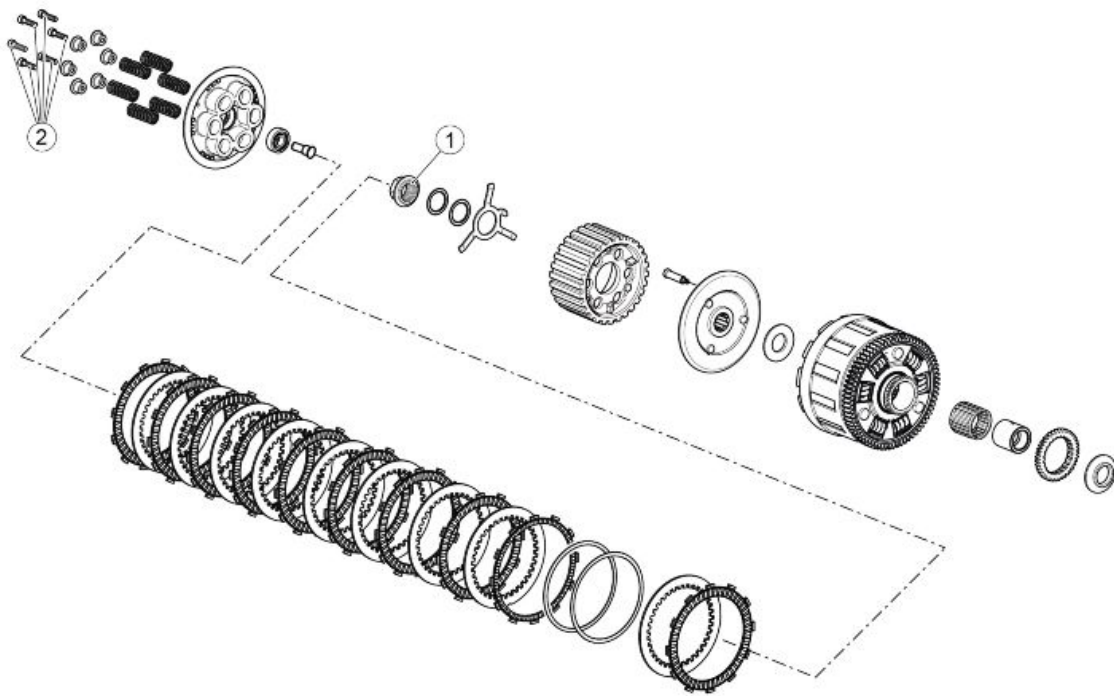

CLUTCH

Pos.	Description	Type	Quantity	Torque	Notes
1	Flanged nut fixing clutch	M20x1	1	150 Nm (110.63 lb ft)	Loct. 243
2	Clutch springs SHC fixing screw	M6x25	6	10 Nm (7.38 lb ft)	-

Removing the clutch cover

- Drain the engine oil.
- Unscrew and remove the five special screws (1) to remove the soundproof cover (2).
- Unscrew and remove the five special screws (3) and the eleven fastening screws (4) around the perimeter, and retrieve the relative washers.

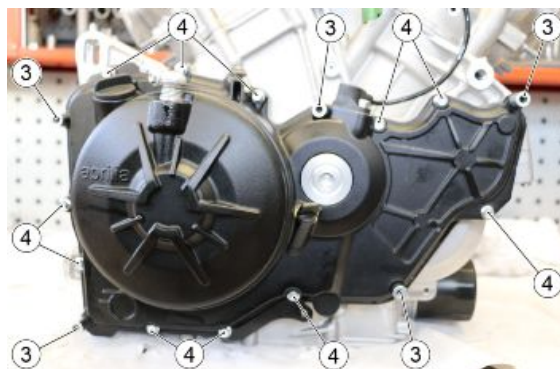

- Remove the clutch casing, retrieving the gasket, the two locator pins and the starter motor transmission gear.



Disassembling the clutch

- Unscrew and remove the tone wheel fixing screw.
- Remove the tone wheel.

- Remove the clutch cover.
- Unscrew and remove the six screws by loosening them 1/4 of a turn at a time; operate in stages and diagonally, and retrieve the washers and the clutch springs.

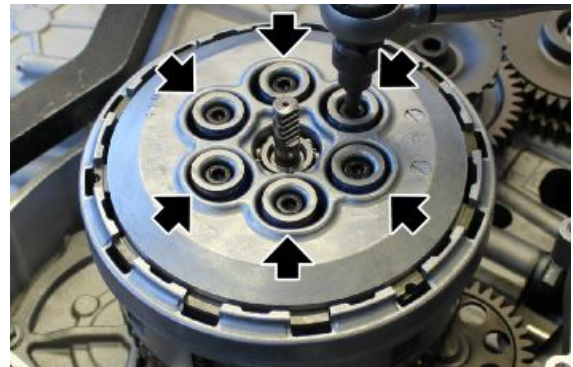

- Remove the thrust plate and the complete control rod.

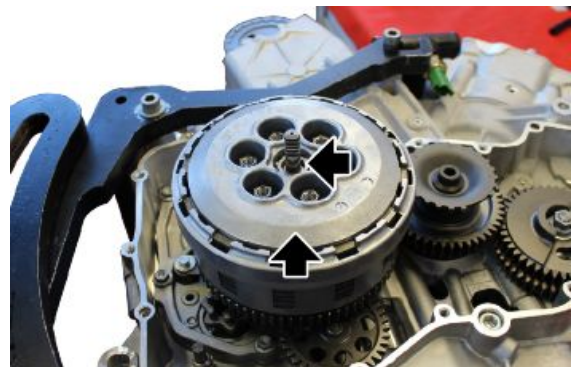

- Remove the discs.

- Block clutch bell rotation using the specific tools.
- Unscrew and remove the clutch bell fixing nut.

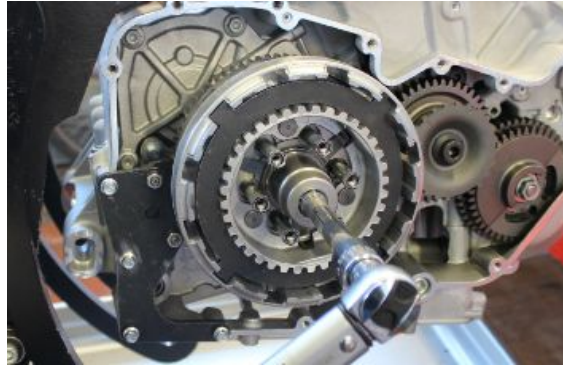
Specific tooling**020849Y Clutch lock**

- Remove the slipper unit.



- Remove the clutch hub.



- Remove the clutch hub cam tower.



- Retrieve the shim.



- Collect the clutch housing.



- Remove the clutch gear that controls the oil/water pumps

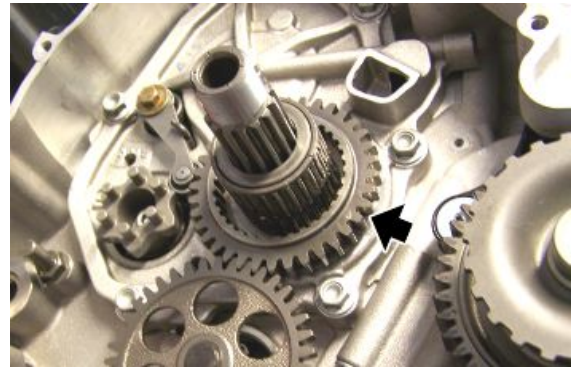

- Remove the needle cage.



- Remove the spacer.



- Remove the thrust bearing.



Checking the clutch plates

Characteristic

Maximum clutch plate deformation (in comparison to a flat surface)

0.15 mm (0.0059 in)

Minimum wear limit of the clutch plate sliding teeth

13.5 mm (0.53 in)

Minimum wear limit of the complete clutch pack thickness (friction discs + steel discs)

47.6 mm (1.87 in)

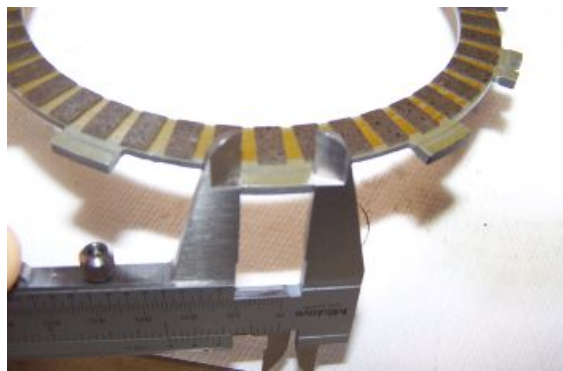

Checking the clutch housing

Check the clutch bell for damage and wear that may result in clutch irregular operation. If necessary, replace the bell.

Check the riveted joint between the clutch housing and the primary drive sprocket for correct sealing and evenness.

Check the primary driven gear for damage and wear and, if necessary, replace the primary driven gear and the clutch bell all together.

Make sure there is not excessive noise during operation; if necessary, replace the primary drive gear and the clutch bell all together.



Checking the pusher plate

Check the thrust plate and the bearing for damage and wear. If necessary, replace the parts.

Characteristic

Maximum deformation permitted on the thrust plate compression surface

0.15 mm (0.0059 in)

Maximum depth of the thrust plate

27.3 mm (1.07 in)



Checking the clutch hub

Check the clutch hub for damage and wear that may result in clutch irregular operation. If necessary, replace the hub.



Checking the springs

NOTE

THE FOLLOWING PROCEDURE IS VALID FOR ALL CLUTCH SPRINGS.

- Check the springs for damage and, if necessary, replace them all together.
- Measure the clutch spring length when unloaded; if necessary, replace the springs all together.

**Characteristic**

Minimum wear limit in the release position of the individual clutch springs

46.8 mm (1.84 in)

Assembling the clutch

- Insert the thrust bearing with the collar facing the gearbox



- Insert the spacer.



- Fit the needle cage.



- Install the clutch gear, making it mesh with the oil/water pump control gear



TURN THE CLUTCH GEAR COLLAR TOWARD THE CLUTCH BELL.

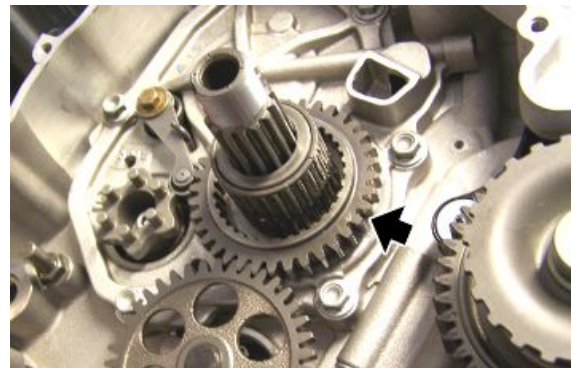

- Insert the clutch bell, making it engage with the engine pinion



- Fit the shim washer.



- Install the clutch hub cam tower.



- Position the clutch hub.



HOUSE THE THREE CLUTCH HUB CAMS IN THE SPECIFIC CLUTCH HUB CAM TOWER INCLINES.



- Fit the three slipper unit clips, offsetting them between each other;
- Install the slipper unit correctly.



- Insert the washer

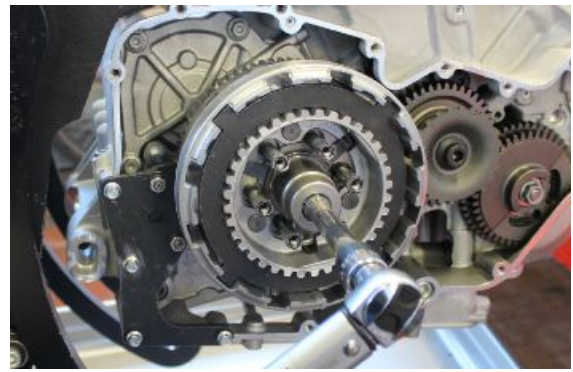

-
- Block clutch housing rotation using the specific tool.
 - Tighten the clutch housing fixing nut.

Specific tooling**020849Y Clutch lock**

-
- Insert the disc with friction material and the black tooth into the bell.



-
- Insert one of the metal discs into the bell.



-
- Insert the flat washer.
 - Insert the spring washer with the concave side facing out.





- Insert the disc covered with friction material into the housing.



- Insert the nitrided metal disc into the clutch housing.



- Continue inserting, alternating a metal disc with one with friction material, ending with a friction material disc with a black tooth.





- Place the control rod together with the thrust bearing and the shim washer.
- Place the thrust plate.



- Fit the clutch springs (3).
- Insert the spring holder cap (2) onto the screws (1).

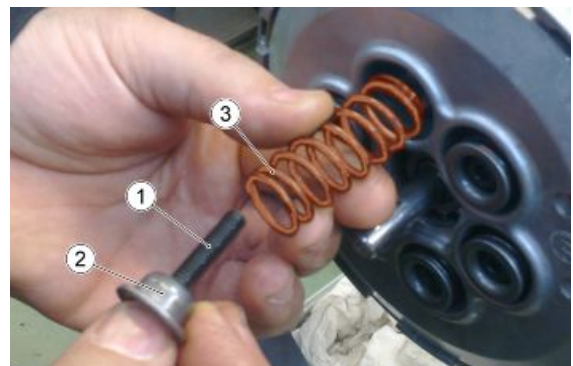

- Tighten the six screws operating in stages and diagonally.

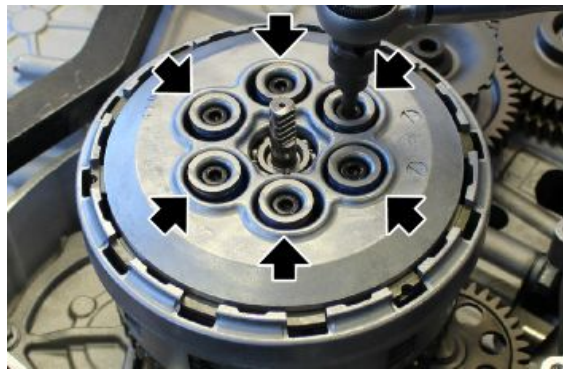

Installing the clutch cover

REMOVING THE CLUTCH CONTROL PIN BUSHING

- Before carrying out the removal of the bushing, it is necessary to thread the inside to allow the extractor to tighten sufficiently.



- Warm up the cover.
- Using a generic extractor, it is then possible to remove the bushing from the cover.



INSTALLING THE CLUTCH CONTROL PIN BUSHING

- Before carrying out the installation of the bushing, it is necessary to warm up the cover.
- Position the guide (1) to insert the bushing (2) as indicated in the figure.
- Insert the bushing so that the processing notch (3) is aligned with the notch on the guide (4).

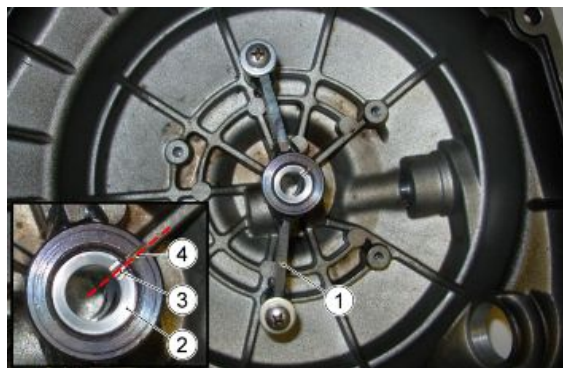

Specific tooling

020926Y Tool for fitting clutch bushing

- Then insert the tool to push the bushing into the seat until it stops.



- Position the starting transmission gear on the crankcase.
- Position the gasket and the two dowel pins in the clutch cover.
- Insert the clutch cover, making sure to have correctly engaged the clutch control lever and the rack shaft.

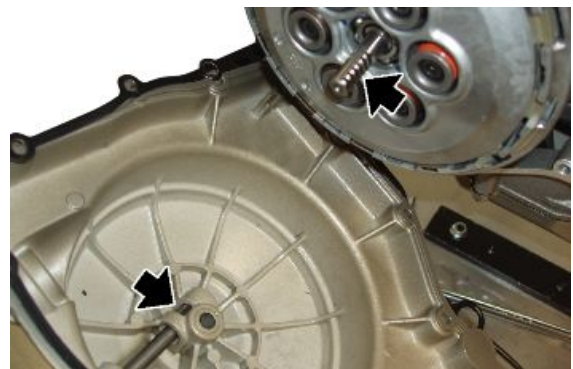

- Insert the five special screws (5) and the eleven fastening screws (6) around the perimeter, taking care to also insert the relative washers.
- Tighten the screws working in stages and diagonally.

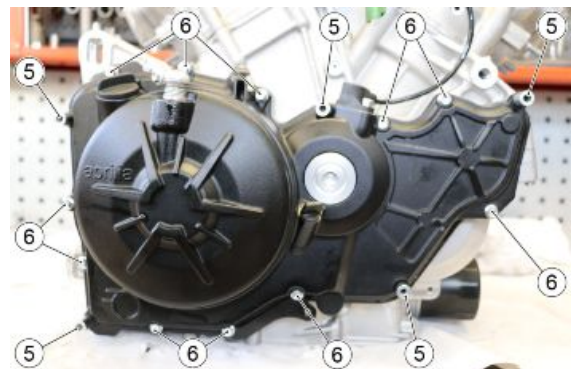

- Position the soundproofing cover (7) with the appropriate fastening screws (8) and tighten them to the required torque

Heads

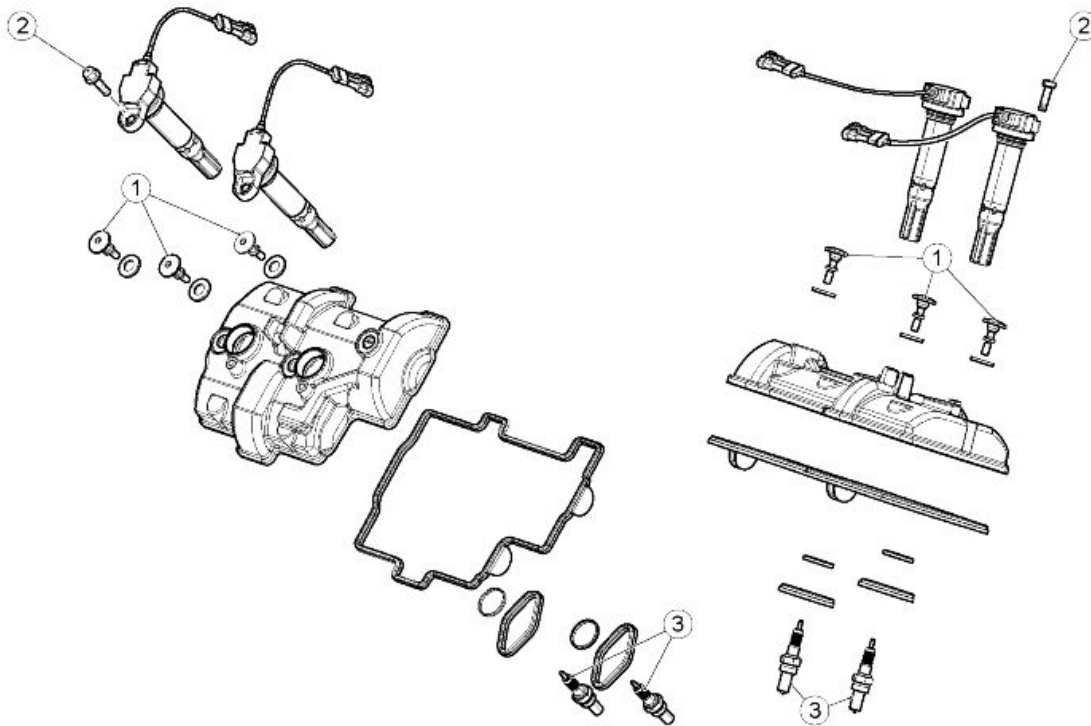

VALVES COVER

Pos.	Description	Type	Quantity	Torque	Notes
1	Head cover fixing screws	-	6	10 Nm (7.38 lb ft)	-
2	TE flanged coil fixing screw	M6x12	4	8 Nm (5.90 lb ft)	Loct. 243
3	Spark plugs	-	4	12 Nm (8.85 lb ft)	-

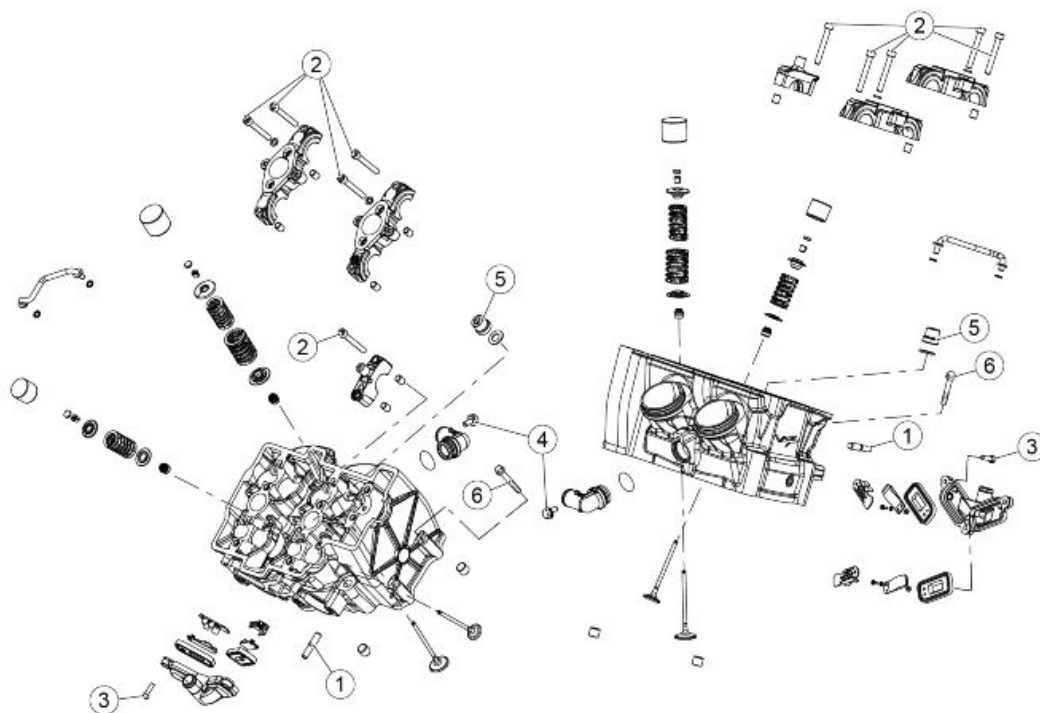

HEADS

Pos.	Description	Type	Quantity	Torque	Notes
1	Exhaust stud bolts	-	8	10 Nm (7.38 lb ft)	-
2	Cam shaft cam tower fixing screws	M6x45	20	11 Nm (8.11 lb ft)	-
3	Reed valve covers fixing screws	-	6	6 Nm (4.43 lb ft)	-
4	Water outlet coupling fixing screw	-	2	10 Nm (7.38 lb ft)	Pre-impregnated or else Loct. 270 or Loct. 648
5	Flanged head nut	-	12	30 + 55 Nm (22.13 + 40.57 lb ft)	Lubricate the head and under the head.
6	Head tightening screw, chain side	M6x55	4	12 Nm (8.85 lb ft)	Lubricate the head and under the head.

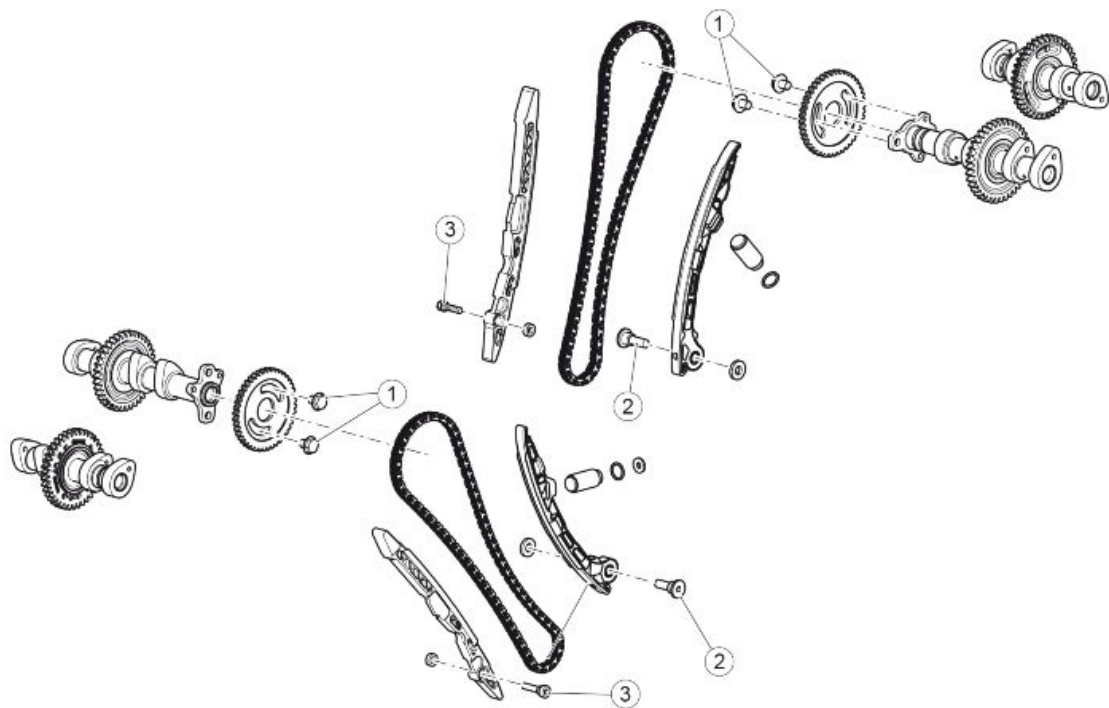

TIMING SYSTEM

Pos.	Description	Type	Quantity	Torque	Notes
1	Screw fastening the timing system gear on the intake shaft	M8	4	30 Nm (22.13 lb ft)	Loct. 243
2	Chain tensioner sliders fastening screws	M8	2	20 Nm (14.75 lb ft)	Loct. 243
3	Chain guide sliders fixing screws	M6x18	2	10 Nm (7.38 lb ft)	Loct. 243

Head cover removal

- Unscrew and remove the three screws with rubber washers

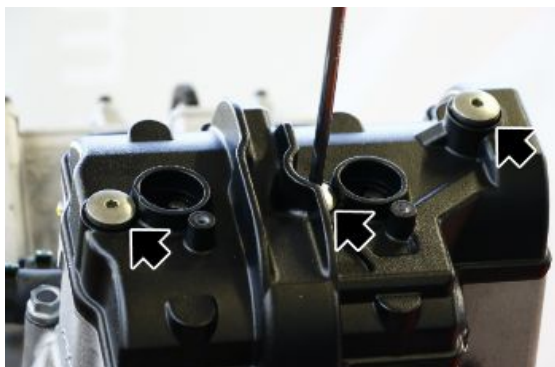

- Remove the head cover together with the sealing gasket



INSTALLATION

- Install a new gasket in the head cover.
- Smear the gasket with suitable sealant, in the area indicated in the figure.

Recommended products

Three bond Sealing paste

-



- Smear the head surface with suitable sealant, in the area indicated in the figure.

Recommended products

Three bond Sealing paste

-

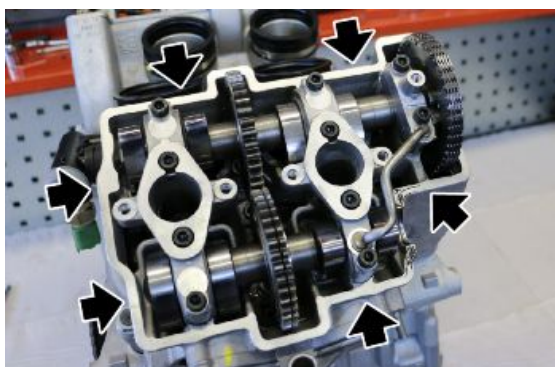

- Fit the head cover.
- Tighten the three screws with rubber washers to the prescribed tightening torque.

Front head

Removing camshafts

- Remove both head covers, the alternator side cover and remove the cap on the clutch cover in order to rotate the crankshaft.
- Remove the O ring.



- Rotate the crankshaft via the opening on the clutch cover.
- Position cylinder 1 piston (LH, rear piston) so that it is at the point where it crosses TDC.
- rotate the crankshaft 150° in the engine rotation direction (direction of travel).

- insert the respective pin, from the flywheel side, into the groove on the crankshaft.



NOTE

THE SPECIAL TOOL SHOWN HERE MUST ONLY BE USED FOR IDENTIFYING THE CORRECT POSITION OF THE CRANKSHAFT.
DO NOT USE IT FOR TIGHTENING COMPONENTS.

Specific tooling

020852Y Crankshaft timing pin

- Fit the pin for aligning the intake camshaft with the hole on U-bolt.
- If it was not possible before adjusting the valve clearance, check the engine timing.



Specific tooling

020851Y Camshaft timing pin

- Remove the two crankshaft and camshaft reference pins.
- Turn the crankshaft until the gear screw covered by the head when the hole on the camshaft gear is aligned with the hole on the U bolt, is visible.
- Block crankshaft rotation using one of the specific tools.
- Unscrew and remove the camshaft gear screw.
- Remove the crankshaft locking tool.



Specific tooling

020850Y Primary gear lock

020914Y Flywheel retainer

Repeat the following operations:

- move cylinder piston 1 (left rear piston) to TDC;
- turn the crankshaft 150° in the direction of engine rotation (direction of travel) in order to align the hole on the intake camshaft with the specific hole on the U bolt; this ensures that all the front cylinder bank valve springs are decompressed.
- Refit the camshaft timing setting pin in the hole in the U bolt on the front head, and refit the crankshaft timing pin from the flywheel side, to check that the timing setting was not altered while the engine was turned with only one camshaft drive gear fastener screw in place.
- Remove the camshaft timing pin.
- Unscrew and remove the three screws (1).
- Remove the U bolt (2) and the oil pipe (3).

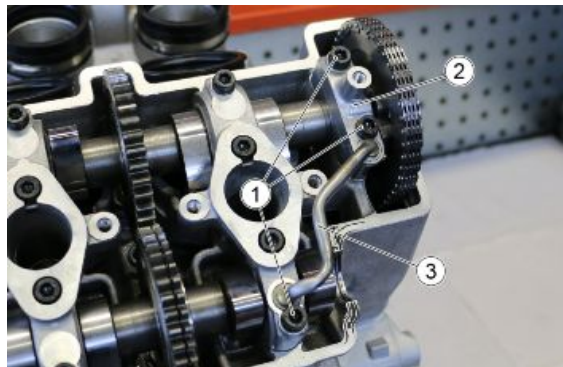

Specific tooling**020851Y Camshaft timing pin****020852Y Crankshaft timing pin**

- Block crankshaft rotation using one of the specific tools.
- Unscrew and remove the second intake camshaft gear screw.
- Leave the gear on the camshaft.

**Specific tooling****020850Y Primary gear lock****020914Y Flywheel retainer**

- Install the specific camshaft gear support tool.
- Fix it to the head using the two screws (1).
- Move the gear from the camshaft to the tool.

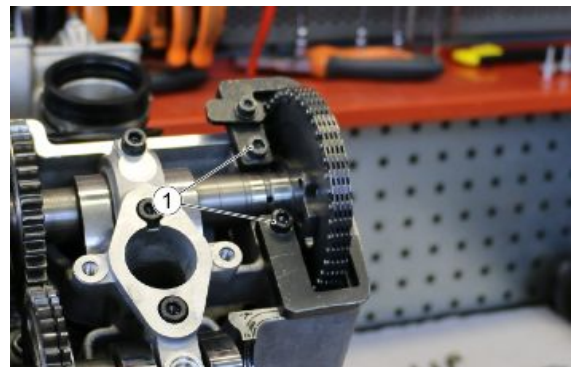
**Specific tooling****020956Y Support for camshaft gear on head**

- Move the gear from the camshaft to the tool and make sure that it is locked by fastening the tool's spacer.

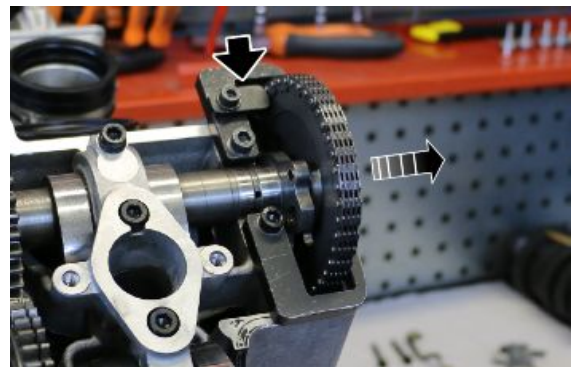

- Unscrew and remove the seven screws (4), proceeding in stages and diagonally.
- Retrieve the washers from the screws near the spark plug holes.
- Remove the U bolts with the O rings and locator pins.

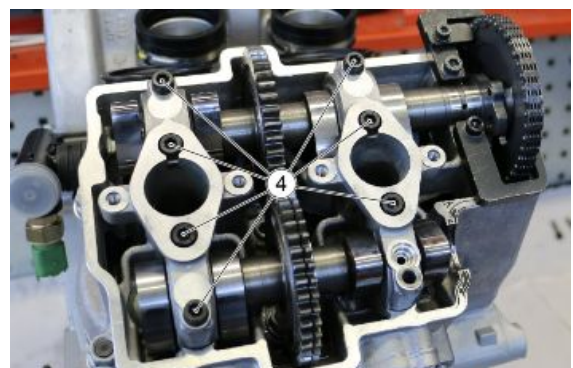

- Remove the intake and exhaust camshafts.

If the two camshafts are timed correctly, the exhaust camshaft gear tooth (indicated with a dot) is meshed with the trough of the intake camshaft gear (indicated with two dots).

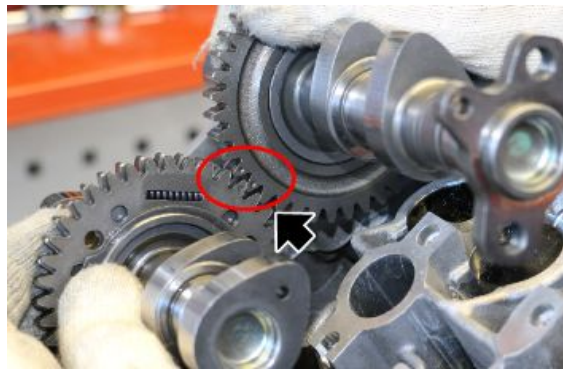

Inspecting camshafts

CAMSHAFT TOOTHED WHEEL CHECK

- Check that the camshaft gear works properly: if it is damaged or does not move smoothly, replace the timing chain and the camshaft gear.

CAMSHAFT LOBES

- Check that they do not show blue colouring, cracks or scratches; otherwise, replace the camshaft, gear and chain.
- Fasten the camshaft horizontally, as shown in the figure, and make it spin to check the eccentricity with a dial gauge; if necessary, replace the part.

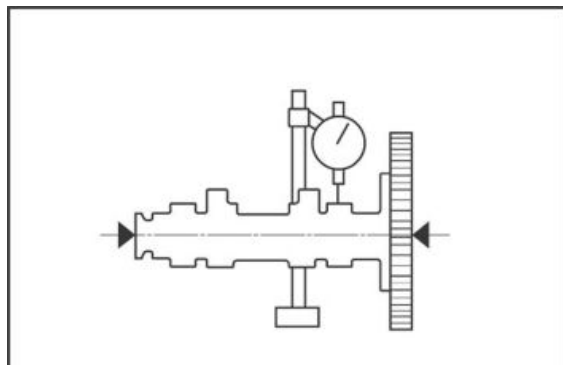

Characteristic

Maximum camshaft axial clearance (intake/outlet)

0.3-0.1 mm (0.012-0.004 in)

Check the timing chain for damage or stiffness while moving.

If necessary, replace the timing chain together with the camshaft gears.

Check the timing chain guide sliders for damage.

If necessary, replace the parts.

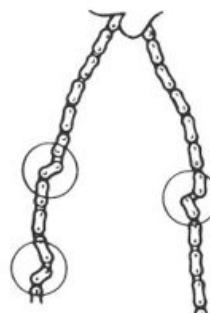

Installing camshafts

NOTE

THE INTAKE AND EXHAUST CAMSHAFTS ARE BOTH DEDICATED FOR THE FRONT AND REAR CYLINDER BANKS.

- Install the intake and exhaust camshafts on the front head, bearing in mind that:

the exhaust camshaft gear tooth (indicated with a dot) is meshed with the trough of the intake camshaft gear (indicated with two dots).



CLEAN THOROUGHLY THE SEATS OF THE GEAR RETAINER SCREWS, ON THE INTAKE CAMSHAFT.

- Fit the U bolts with nine O rings and locator pins.
- Position the screws (4), taking care to insert new washers on the screws near the spark plug holes.

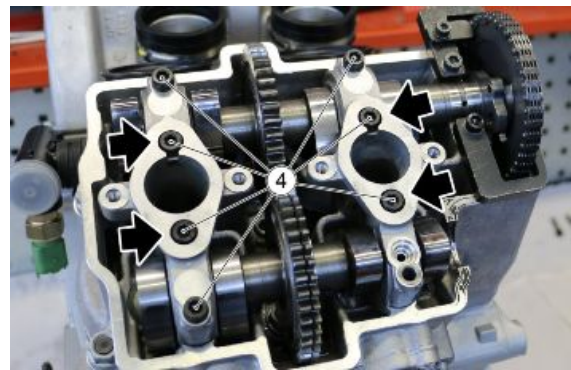
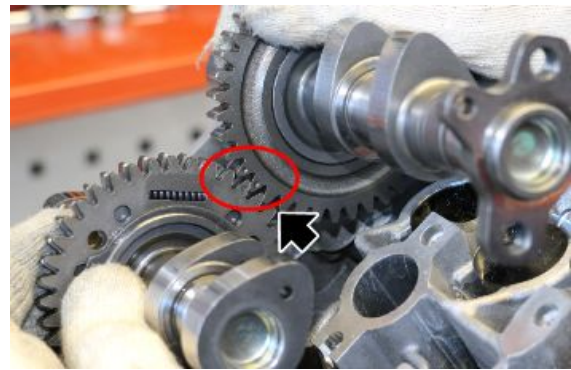

- Loosen the distribution gear's lock screw and move the gear itself from the mounting tool to the camshaft.
- Unscrew and remove the two screws (1).
- Remove the tool.

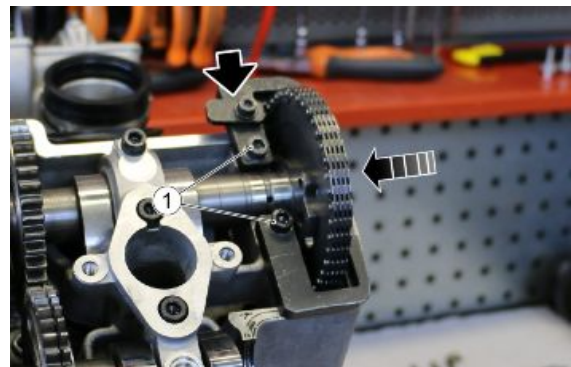

- Position the U bolt (2) and the oil pipe (3).
- Insert the two screws (1).
- Tighten all the U bolts' screws working in stages and diagonally.

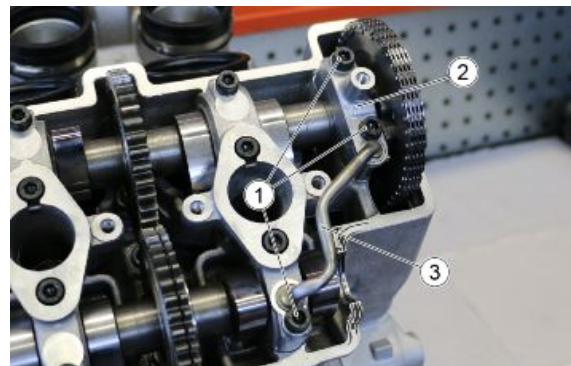

- Align the intake camshaft with the specific hole on the U bolt.
- Insert the specified pin.

Specific tooling

020851Y Camshaft timing pin



- Apply Loctite 243 thread lock on the thread of the timing gear fastener screw. This screw must be replaced at each reassembly.
- Apply and loosely tighten the gear fixing screw on the camshaft.



- Block crankshaft rotation using one of the specific tools.
- Tighten the gear fixing screw on the camshaft to exactly the torque specified.
- Remove the crankshaft locking tool.



Specific tooling

020850Y Primary gear lock

020914Y Flywheel retainer

- Remove the two crankshaft and camshaft reference pins.
- Turn the crankshaft until the gear screw covered by the head when the hole on the camshaft gear is aligned with the hole on the U bolt, is visible.
- Block crankshaft rotation using one of the specific tools.
- Apply Loctite 243 thread lock on the thread of the second gear fastener



screw. This screw must be replaced at each reassembly.

- Tighten the second camshaft gear fixing screw to exactly the torque specified.
- Remove the crankshaft locking tool.
- Turn the crankshaft back to the previous position in which the camshaft and U bolt holes were aligned; insert the reference pin while checking with the crankshaft reference pin, that the flywheel side hole and the hole on the crankshaft are perfectly aligned.
- If this is not the case, repeat the timing operations.

Specific tooling

020851Y Camshaft timing pin

020852Y Crankshaft timing pin

Front head removal

- Remove both head covers, the alternator side cover and remove the cap on the clutch cover in order to rotate the crankshaft.
- Remove the O ring.



- Turn the crankshaft from the hole on the clutch cover.
 - Move cylinder piston 1 (left rear piston) to the overlap TDC;
 - Turn the crankshaft 150° in the engine rotation direction (direction of travel), in order to align the hole on the intake camshaft with the specific hole on the U bolt; this ensures that all the front cylinder bank valve springs are decompressed.
-

- Turn the crankshaft until the gear screw covered by the head when the hole on the camshaft gear is aligned with the hole on the U bolt, is visible.
- Block crankshaft rotation using one of the specific tools.
- Unscrew and remove the camshaft gear screw.
- Remove the crankshaft locking tool.



Specific tooling

020850Y Primary gear lock

020914Y Flywheel retainer

Repeat the following operations:

- move cylinder piston 1 (left rear piston) to TDC;
- turn the crankshaft 150° in the engine rotation direction (direction of travel), in order to align the hole on the intake camshaft with the specific hole on the U bolt; this ensures that all the front cylinder bank valve springs are decompressed.
- Block crankshaft rotation using one of the specific tools.
- Unscrew and remove the second intake camshaft gear screw.
- Remove the crankshaft locking tool.



Specific tooling

020850Y Primary gear lock

020914Y Flywheel retainer

- Slide and remove the gear from the intake camshaft



- Unscrew and remove the ten screws (1-2), proceeding in stages and in a crossed pattern.
- Retrieve the washers from the screws (2) near the spark plug holes.
- Remove the U bolts with the O rings and locator pins.

**NOTE**

MARK THE COMPONENTS TO PREVENT INCORRECT RE-FITTING.

- Remove the intake and exhaust camshafts from the front head.
- Unscrew and remove the chain sliders' screws.
- Remove the chain sliders.

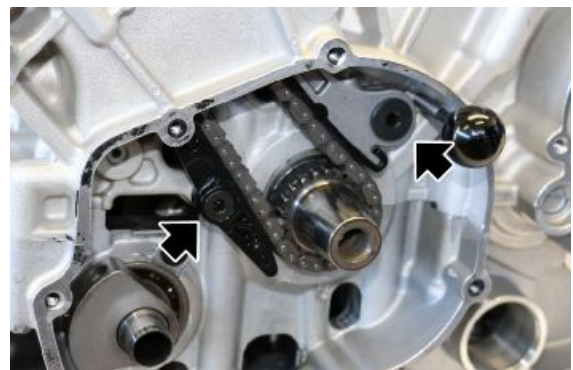

- Unscrew and remove the two head fixing screws (a - b) from the flywheel side.

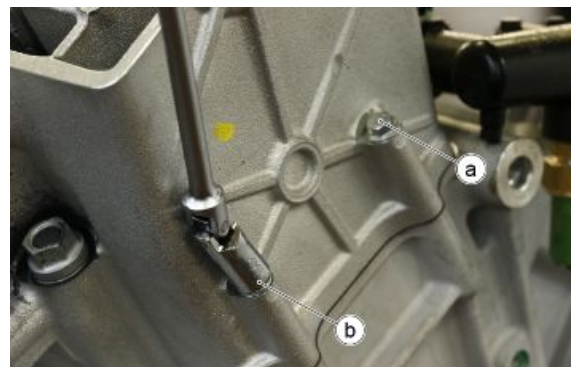

- Loosen the six nuts on the stud bolts, proceeding in the following order 6 - 5 - 4 - 3 - 2 - 1.
- After loosening all nuts, remove them in order indicated above.



- Remove the front head, slipping it off the stud bolts.
- Collect the gasket and the two dowel pins.

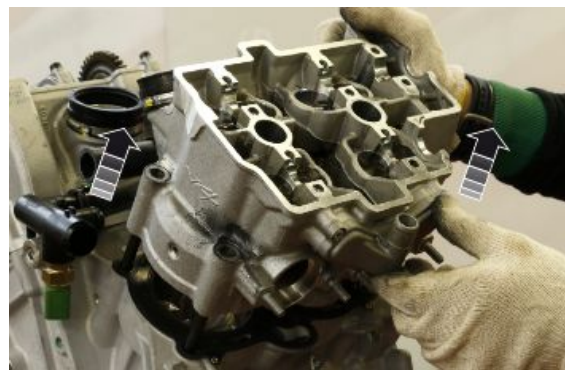

- Remove the chain tensioner complete with O-ring using the specific tool.
- If the O-ring is not on the chain tensioner, make sure it was not left in the crankcase seat.



REPLACE THE O RING UPON EACH REMOVAL.

Specific tooling

020883Y Fitting/removing timing chain tensioner tool



Front head check

Check that:

- The contact surfaces with the cover and the crankcase are not scored or damaged so they jeopardise a perfect seal.
- Check the status of the valve seats.
- Check that the routing of the oil pipes is free and if required, clean them by blowing a jet of compressed air.

Front head fitting

- Install a new O ring on the chain tensioner



REPLACE THE O RING UPON EACH REMOVAL.



- Compress the chain tensioner completely, making sure that the total length is 40.05 ± 0.5 mm (1.58 ± 0.02 in).

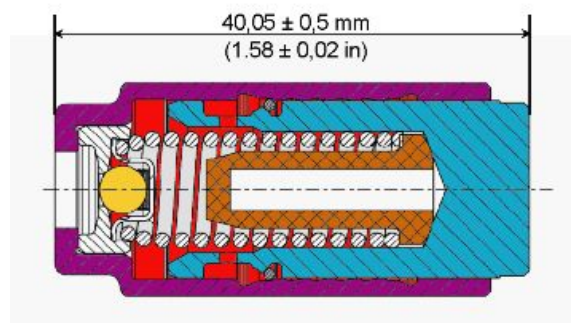

- Insert the chain tensioner into the crankcase, being careful to position it correctly.



THE WASHER SHALL ONLY BE INSTALLED ON THE FRONT CHAIN TENSIONER

WASHER

- We recommend installing a washer between the front crankcase and the chain tensioner to optimise the functionality of the timing system.
- This washer is available as a spare part.
- Fit the washer onto the front chain tensioner then install the chain tensioner in the relative seat in the crankcase. Take particular care to ensure that the washer seats correctly, as the functionality of the timing system may be compromised if the washer is bent or incorrectly positioned.



-
- Place a new gasket between the crankcase and the head.
 - Place the two dowel pins.



-
- Install the head.



- Pretighten the six nuts on the stud bolts proceeding in the following order: 1 - 2 - 3 - 4 - 5 - 6.
- Then tighten them fully following the same order.



- Tighten the two screws according to the sequence (a - b).

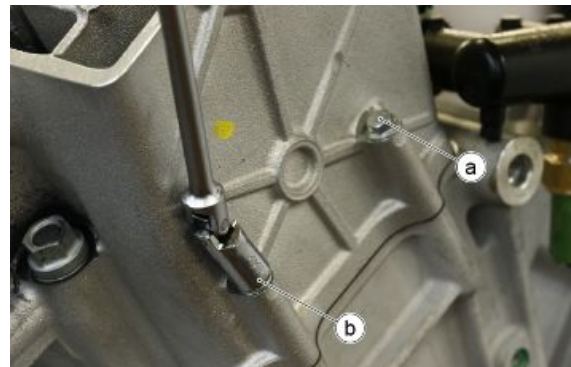

- Fit the camshaft gear
- Keep the gear in position with the chain tightened



THE SIDE WITH THE BEVELLED HOLE IN THE TIMING SYSTEM GEAR MUST ALWAYS FACE THE EXTERIOR OF THE HEAD.



- Install both chain sliders and fasten them with the specific screws.



- Rotate the crankshaft via the opening on the clutch cover.
- Position cylinder 1 piston (LH, rear piston) so that it is at the point where it crosses TDC.

- rotate the crankshaft 150° in the engine rotation direction (direction of travel).
- insert the respective pin, from the fly-wheel side, into the groove on the crankshaft.

NOTE

THE SPECIAL TOOL SHOWN HERE MUST ONLY BE USED FOR IDENTIFYING THE CORRECT POSITION OF THE CRANKSHAFT. DO NOT USE IT FOR TIGHTENING COMPONENTS.

Specific tooling

020852Y Crankshaft timing pin



NOTE

THIS ENGINE HAS CAMSHAFTS OF THE EXHAUST VALVES WITH CLEARANCE RECOVERY.

- Install the intake and exhaust camshafts on the front head, bearing in mind that:

the exhaust camshaft gear tooth (indicated with a dot) is meshed with the trough of the intake camshaft gear (indicated with two dots).



CLEAN THOROUGHLY THE SEATS OF THE GEAR RETAINER SCREWS, ON THE INTAKE CAMSHAFT.

- Check the number engraved on the U bolts, which must correspond with the one engraved on the head.
- If the U bolts between the two heads are inverted, camshaft seizure may occur

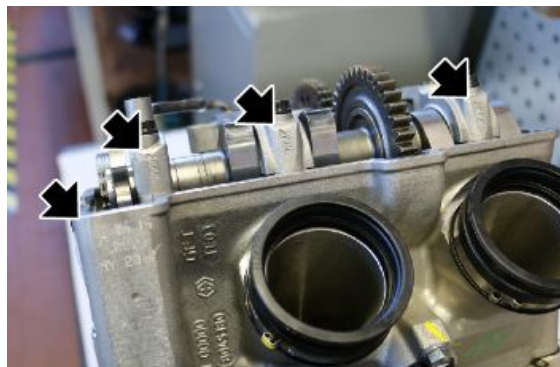

IT IS NOT POSSIBLE TO REPLACE ONLY ONE U BOLT, IF NECESSARY: REPLACE THE ENTIRE HEAD.

- Fit the U bolts with the nine O rings and locator pins.
- Install the oil pipe.
- Fit the new washers under the screws (2) near the spark plug holes only.
- Tighten the ten screws (1 - 2) working in stages and diagonally.



- Cut the clamp that binds the chain to the gear.
- Position the gear on the camshaft so that the timing hole and the gear fixing screw hole are centred with the gear slot.
- Insert the specific timing pin.



Specific tooling

020851Y Camshaft timing pin

- Apply Loctite 243 thread lock on the thread of the timing gear fastener screw. This screw must be replaced at each reassembly.
- Apply and loosely tighten the gear fixing screw on the camshaft.



- Protect the edge of the head with rubber.
- Load the chain tensioner with special tool.

Specific tooling

020981Y Lever for disarming the hydraulic tensioner of the timing chain

- Block crankshaft rotation using one of the specific tools.
- Tighten the gear fixing screw on the camshaft to exactly the torque specified.
- Remove the crankshaft locking tool.



Specific tooling

020850Y Primary gear lock

020914Y Flywheel retainer

- Remove the two crankshaft and camshaft reference pins.
- Turn the crankshaft until the gear screw covered by the head when the hole on the camshaft gear is aligned with the hole on the U bolt, is visible.
- Block crankshaft rotation using one of the specific tools.
- Apply Loctite 243 thread lock on the thread of the second gear fastener screw. This screw must be replaced at each reassembly.
- Tighten the second camshaft gear fixing screw to exactly the torque specified.
- Remove the crankshaft locking tool.
- Turn the crankshaft back to the previous position in which the camshaft and U bolt holes were aligned; insert the reference pin while checking with the crankshaft reference pin, that the flywheel side hole and the hole on the crankshaft are perfectly aligned.
- If this is not the case, repeat the timing operations.



Specific tooling

020851Y Camshaft timing pin

020852Y Crankshaft timing pin

Rear head

Removing camshafts

- Remove the rear head cover and the clutch cover.
 - Move cylinder piston 1 (left rear piston) to the TDC;
 - Turn the crankshaft 450° (one complete turn + 90°) in the direction of motor rotation (direction of travel).
-
- Insert the pin from the clutch side into the hole in the crankshaft.

NOTE

THE SPECIAL TOOL SHOWN HERE MUST ONLY BE USED FOR IDENTIFYING THE CORRECT POSITION OF THE CRANKSHAFT. DO NOT USE IT FOR TIGHTENING COMPONENTS.

Specific tooling

020852Y Crankshaft timing pin



- Fit the pin for aligning the intake camshaft with the hole on U-bolt.
- If it was not possible before adjusting the valve clearance, check the engine timing.

Specific tooling

020851Y Camshaft timing pin



- Remove the two crankshaft and camshaft reference pins.
- Turn the crankshaft until the gear screw covered by the head when the hole on the camshaft gear is aligned with the hole on the U bolt, is visible.
- Block crankshaft rotation using one of the specific tools.
- Unscrew and remove the camshaft gear screw.
- Remove the crankshaft locking tool.

Specific tooling

020850Y Primary gear lock

020914Y Flywheel retainer



Repeat the following operations:

- Move cylinder piston 1 (left rear piston) to TDC;
- Turn the crankshaft by 450° (one complete turn + 90°) in the direction of the engine's rotation (direction of travel) to align the hole on the intake camshaft with the specific hole on the U bolt; This ensures that all the rear cylinder bank valve springs are decompressed.
- Refit the camshaft timing setting pin in the hole in the U bolt on the rear head, and refit the crankshaft timing pin from the clutch side, to check that the timing setting was not altered while the engine was turned with only one camshaft drive gear fastener screw in place.
- Remove the camshaft timing pin.
- Unscrew and remove the two screws (1) from the U bolt (2).
- Remove the U bolt (2) and the oil pipe (3).

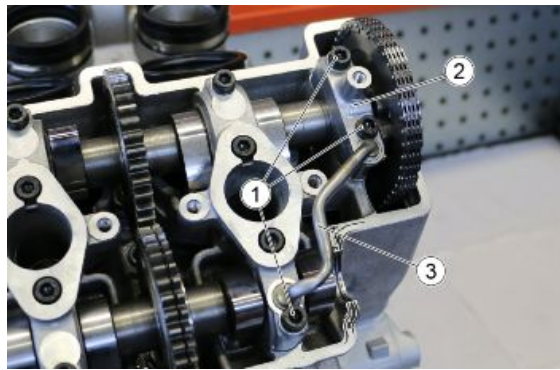

Specific tooling

020851Y Camshaft timing pin

020852Y Crankshaft timing pin

- Block crankshaft rotation using one of the specific tools.
- Unscrew and remove the second intake camshaft gear screw.
- Leave the gear on the camshaft.

Specific tooling

020850Y Primary gear lock

020914Y Flywheel retainer



- Install the specific camshaft gear support tool.
- Fix it to the head using the two screws (1).

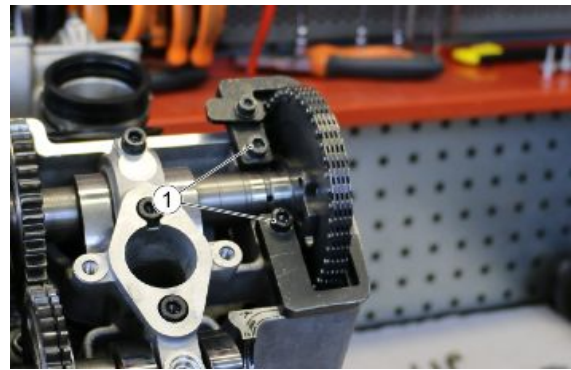

Specific tooling

020956Y Support for camshaft gear on head

- Move the gear from the camshaft to the tool and make sure that it is locked by fastening the tool's spacer.

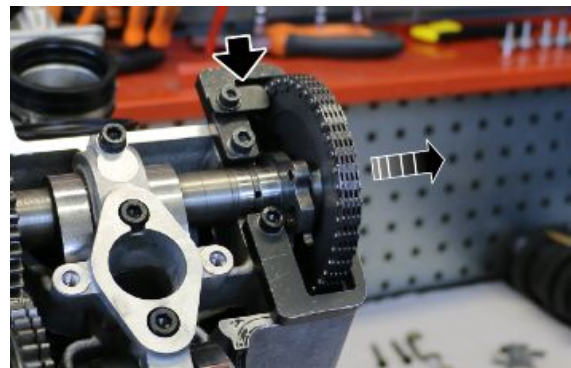

- Unscrew and remove the seven screws (4), proceeding in stages and diagonally.
- Retrieve the washers from the screws near the spark plug holes.
- Remove the U bolts with the O rings and locator pins.

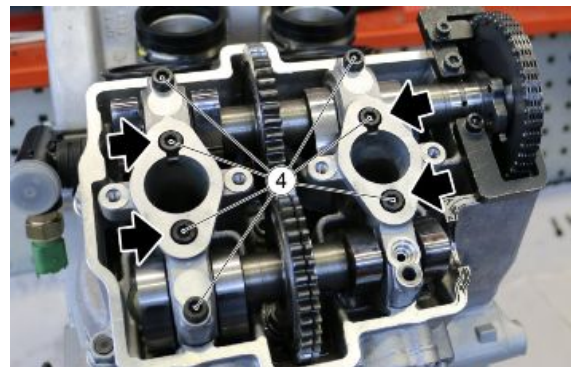

- Remove the intake and exhaust camshafts.

If the two camshafts are timed correctly, the intake camshaft gear tooth (indicated with one dot) is meshed with the trough of the exhaust camshaft gear (indicated with two dots).

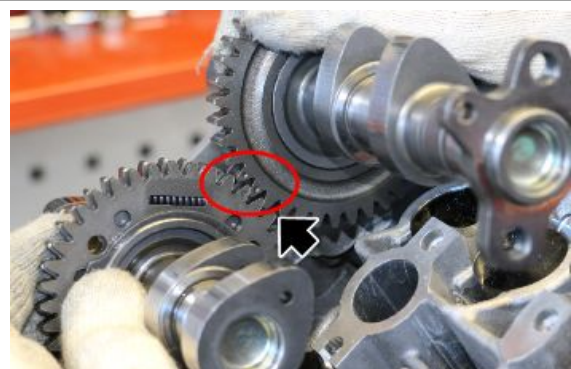

Inspecting camshafts

CAMSHAFT TOOTHED WHEEL CHECK

- Check that the camshaft gear works properly: if it is damaged or does not move smoothly, replace the timing chain and the camshaft gear.

CAMSHAFT LOBES

- Check that they do not show blue colouring, cracks or scratches; otherwise, replace the camshaft, gear and chain.

- Fasten the camshaft horizontally, as shown in the figure, and make it spin to check the eccentricity with a dial gauge; if necessary, replace the part.

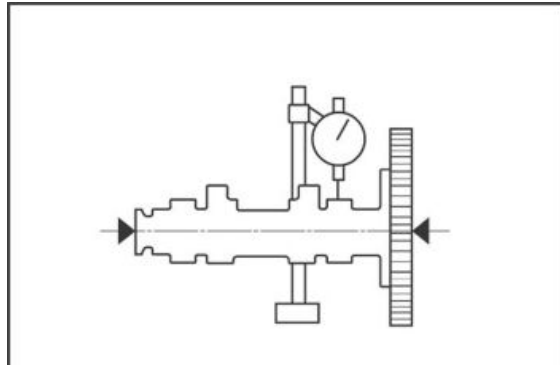

Characteristic

Maximum camshaft axial clearance (intake/outlet)

0.3-0.1 mm (0.012-0.004 in)

Check the timing chain for damage or stiffness while moving.

If necessary, replace the timing chain together with the camshaft gears.

Check the timing chain guide sliders for damage.

If necessary, replace the parts.



Installing camshafts

NOTE

THE INTAKE AND EXHAUST CAMSHAFTS ARE BOTH DEDICATED FOR THE FRONT AND REAR CYLINDER BANKS.

- Install the intake and exhaust camshafts on the rear head, remembering that:

the intake camshaft gear tooth (indicated with a dot) is inserted in the groove of the exhaust camshaft gear (indicated with two dots).

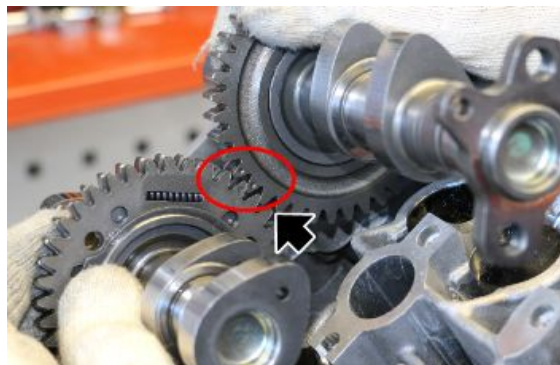

CLEAN THOROUGHLY THE SEATS OF THE GEAR RETAINER SCREWS, ON THE INTAKE CAMSHAFT.

- Fit the U bolts with nine O rings and locator pins.
- Position the screws (4), taking care to insert new washers on the screws near the spark plug holes.

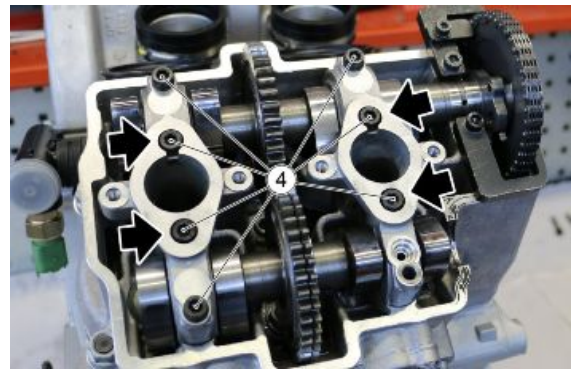

- Loosen the distribution gear's lock screw and move the gear itself from the mounting tool to the camshaft.
- Unscrew and remove the two screws (1).
- Remove the tool.

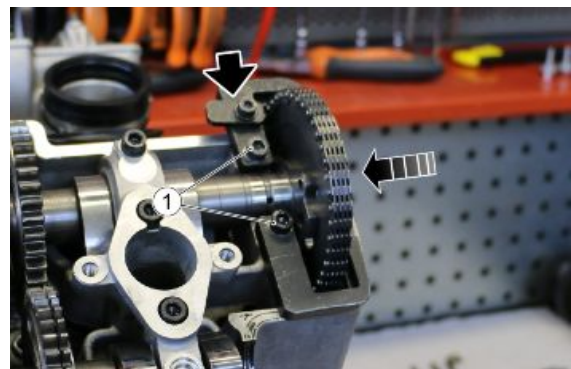

- Position the U bolt (2) and the oil pipe (3).
- Insert the two screws (1).
- Tighten all the U bolts' screws working in stages and diagonally.

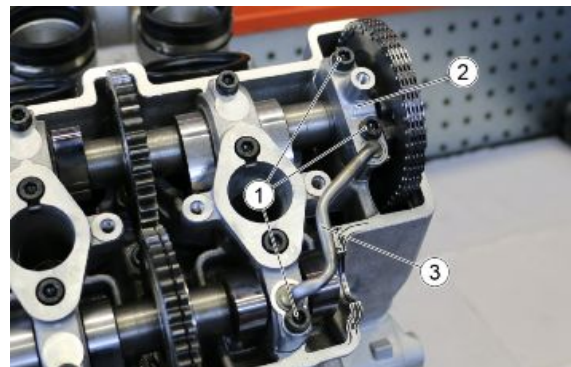

- Fit the U bolt and the oil pipe.
- Tighten the two U bolt screws (1) and the screw (2) that was not fitted previously.





- Align the intake camshaft with the specific hole on the U bolt.
- Insert the specified pin.

Specific tooling

020851Y Camshaft timing pin



- Apply Loctite 243 thread lock on the thread of the timing gear fastener screw. This screw must be replaced at each reassembly.
- Apply and loosely tighten the gear fixing screw on the camshaft.



- Block crankshaft rotation using one of the specific tools.
- Tighten the gear fixing screw on the camshaft to exactly the torque specified.
- Remove the crankshaft locking tool.



Specific tooling

020850Y Primary gear lock

020914Y Flywheel retainer

- Remove the two crankshaft and camshaft reference pins.
- Turn the crankshaft until the gear screw covered by the head when the hole on the camshaft gear is aligned with the hole on the U bolt, is visible.
- Block crankshaft rotation using one of the specific tools.
- Apply Loctite 243 thread lock on the thread of the second gear fastener screw. This screw must be replaced at each reassembly.
- Tighten the second camshaft gear fixing screw to exactly the torque specified.
- Remove the crankshaft locking tool.



Specific tooling

020850Y Primary gear lock

020851Y Camshaft timing pin

020852Y Crankshaft timing pin

020914Y Flywheel retainer

- Turn the crankshaft back to the previous position in which the camshaft and U bolt holes were aligned; Refit the reference pin while checking, using the crankshaft reference pin, that the clutch side hole and the hole in the crankshaft are perfectly aligned.
- If this is not the case, repeat the timing operations.

Specific tooling

020851Y Camshaft timing pin

020852Y Crankshaft timing pin

Rear head removal

- Remove the rear head cover and the clutch cover.
- Move cylinder piston 1 (left rear piston) to the TDC;
- Turn the crankshaft 450° (one complete turn + 90°) in the direction of motor rotation (direction of travel) in order to align the hole on the intake camshaft gear with the hole on the U-bolt. This ensures that all the rear cylinder bank valve springs are decompressed.

- Turn the crankshaft until the gear screw covered by the head when the hole on the camshaft gear is aligned with the hole on the U bolt, is visible.
- Block crankshaft rotation using one of the specific tools.
- Unscrew and remove the camshaft gear screw.
- Remove the crankshaft locking tool.

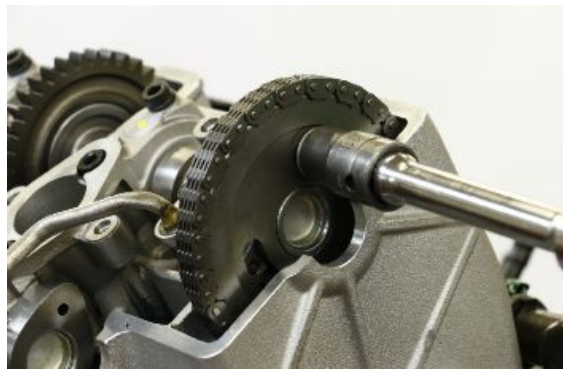

Specific tooling

020850Y Primary gear lock

020914Y Flywheel retainer

Repeat the following operations:

- move cylinder piston 1 (left rear piston) to TDC;
- turn the crankshaft by 450° (one complete turn + 90°) in the direction of engine rotation (direction of travel) to align the hole on the intake camshaft with the specific hole on the U bolt. This ensures that all the rear cylinder bank valve springs are decompressed.
- Block crankshaft rotation using one of the specific tools.
- Unscrew and remove the second intake camshaft gear screw.
- Remove the crankshaft locking tool.



Specific tooling

020850Y Primary gear lock

020914Y Flywheel retainer Kokusan

- Slide and remove the gear from the intake camshaft



- Unscrew and remove the ten screws (1-2), proceeding in stages and in a crossed pattern.
- Retrieve the washers from the screws (2) near the spark plug holes.
- Remove the U bolts with the O rings and locator pins.

**NOTE**

MARK THE COMPONENTS TO PREVENT INCORRECT RE-FITTING.

- Remove the intake and exhaust camshafts from the rear head.
- Remove the clutch, the tone wheel, and the primary drive gear.

- Unscrew and remove the chain sliders' screws.
- Remove the chain sliders.

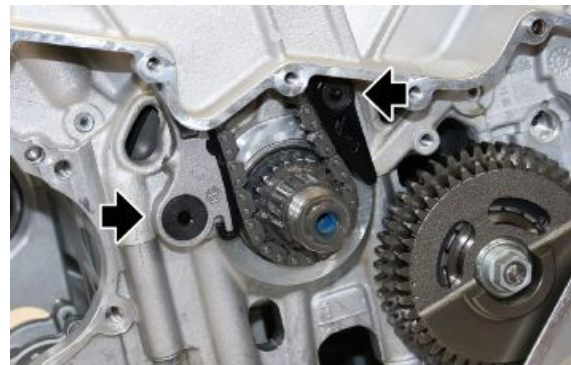

- Unscrew and remove the two head fastener screws (a - b) from the clutch side.

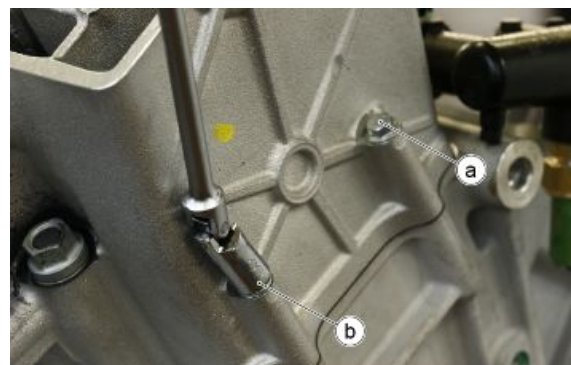

- Loosen the six nuts on the stud bolts, proceeding in the following order 6 - 5 - 4 - 3 - 2 - 1.
- After loosening all nuts, remove them in order indicated above.



- Remove the rear head, slipping it off the stud bolts.
- Collect the gasket and the two dowel pins.



- Remove the chain tensioner complete with O-ring using the specific tool.
- If the O-ring is not on the chain tensioner, make sure it was not left in the crankcase seat.



REPLACE THE O RING UPON EACH REMOVAL.

Specific tooling

020883Y Fitting/removing timing chain tensioner tool



Rear head check

Check that:

- The contact surfaces with the cover and the crankcase are not scored or damaged so they jeopardise a perfect seal.
- Check the status of the valve seats.
- Check that the routing of the oil pipes is free and if required, clean them by blowing a jet of compressed air.

Rear head fitting

- Install a new O ring on the chain tensioner



REPLACE THE O RING UPON EACH REMOVAL.



- Compress the chain tensioner completely, making sure that the total length is $40,05 \pm 0,5$ mm ($1,58 \pm 0,02$ in).

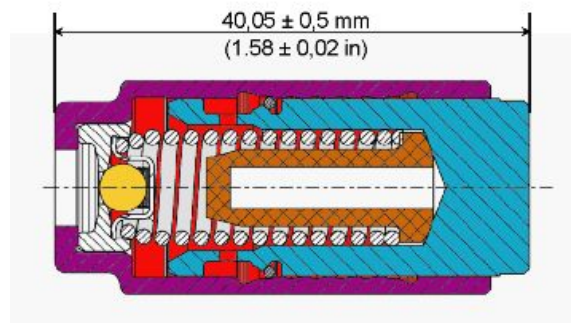

- Insert the chain tensioner into the crankcase, being careful to position it correctly.



- Place a new gasket between the crankcase and the head.
- Place the two dowel pins.



- Install the head.



- Pretighten the six nuts on the stud bolts proceeding in the following order: 1 - 2 - 3 - 4 - 5 - 6.
- Then tighten them fully following the same order.



- Tighten the two screws according to the sequence (a - b).

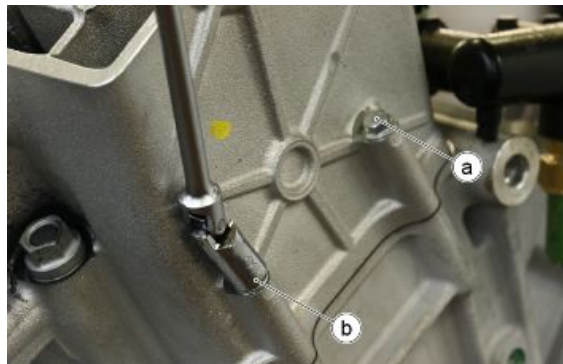

- Fit the camshaft gear
- Keep the gear in position with the chain tightened



THE SIDE WITH THE BEVELLED HOLE IN THE TIMING SYSTEM GEAR MUST ALWAYS FACE THE EXTERIOR OF THE HEAD.



- Install both chain sliders and fasten them with the specific screws.

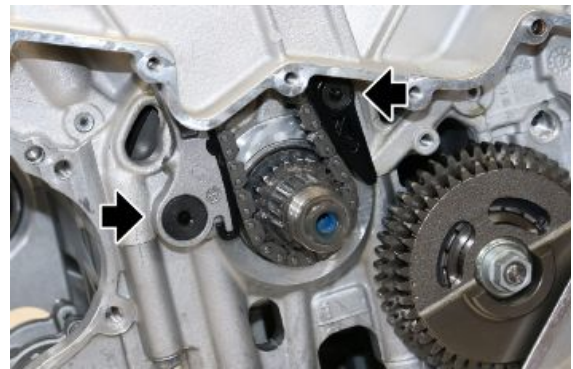

NOTE

THIS ENGINE HAS CAMSHAFTS OF THE EXHAUST VALVES WITH CLEARANCE RECOVERY.

- Install the intake and exhaust camshafts on the rear head, remembering that:

the intake camshaft gear tooth (indicated with a dot) is inserted in the groove of the exhaust camshaft gear (indicated with two dots).



CLEAN THOROUGHLY THE SEATS OF THE GEAR RETAINER SCREWS, ON THE INTAKE CAMSHAFT.



- Check the number engraved on the U bolts, which must correspond with the one engraved on the head.
- If the U bolts between the two heads are inverted, camshaft seizure may occur



IT IS NOT POSSIBLE TO REPLACE ONLY ONE U BOLT, IF NECESSARY: REPLACE THE ENTIRE HEAD.

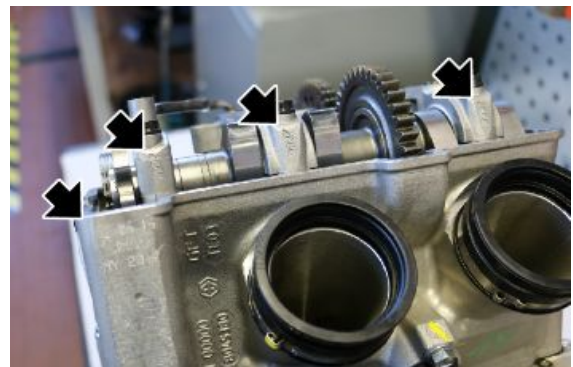

- Fit the U bolts with the nine O rings and locator pins.
- Install the oil pipe.
- Fit the new washers under the screws (2) near the spark plug holes only.
- Tighten the ten screws (1 - 2) working in stages and diagonally.



- Cut the clamp that binds the chain to the gear.
- Position the gear on the camshaft so that the timing hole and the gear fixing screw hole are centred with the gear slot.
- Insert the specific timing pin.



Specific tooling

020851Y Camshaft timing pin

- Apply Loctite 243 thread lock on the thread of the timing gear fastener screw. This screw must be replaced at each reassembly.
- Apply and loosely tighten the gear fixing screw on the camshaft.



- Protect the edge of the head with rubber.
- Load the chain tensioner with special tool.

Specific tooling

020981Y Lever for disarming the hydraulic tensioner of the timing chain

- Block crankshaft rotation using one of the specific tools.
- Tighten the gear fixing screw on the camshaft to exactly the torque specified.
- Remove the crankshaft locking tool.

**Specific tooling****020850Y Primary gear lock****020914Y Flywheel retainer**

- Remove the two crankshaft and camshaft reference pins.
- Turn the crankshaft until the gear screw covered by the head when the hole on the camshaft gear is aligned with the hole on the U bolt, is visible.
- Block crankshaft rotation using one of the specific tools.
- Apply Loctite 243 thread lock on the thread of the second gear fastener screw. This screw must be replaced at each reassembly.
- Tighten the second camshaft gear fixing screw to exactly the torque specified.
- Remove the crankshaft locking tool.

**Specific tooling****020850Y Primary gear lock****020851Y Camshaft timing pin****020852Y Crankshaft timing pin****020914Y Flywheel retainer**

- Turn the crankshaft back to the previous position in which the camshaft and U bolt holes were aligned; Refit the reference pin while checking, using the crankshaft reference pin, that the clutch side hole and the hole in the crankshaft are perfectly aligned.
- If this is not the case, repeat the timing operations.

Specific tooling

020851Y Camshaft timing pin

020852Y Crankshaft timing pin

Valves

Valve removal

- Remove the head.
- Place the head on supporting surface.
- Number the valves and their bucket tappets in order to position them correctly upon refitting.

- Extract the bucket tappets



- Extract the adjusting shims



- Compress the valve springs with the specific wrench and with the spring compressing tool.



Specific tooling

AP8140179 Valve springs compressor

020853Y Compresses intake valve springs

020854Y Compresses exhaust valve springs

See also

Front head removal

Rear head removal

- Remove the cotters using a magnet.



- Release the valve springs.
- Remove the upper cap and the springs.

CAUTION

THE INTAKE VALVES HAVE A DOUBLE SPRING WHEREAS THE EXHAUST VALVES HAVE A SINGLE SPRING.

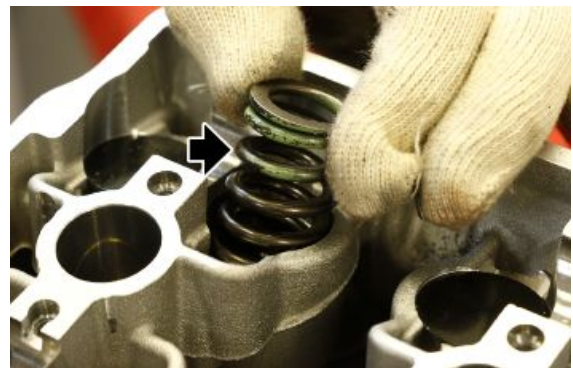

- Remove the valves.



Valve check

CAUTION

REPLACE THE VALVES ONE AT A TIME. DO NOT MIX THE COMPONENTS. EACH VALVE MUST BE INSERTED INTO ITS SEAT, WHICH IS MARKED PRIOR TO REMOVAL.

VALVE STEM DEVIATION

Lift up the valve approx. 10 mm (0.39 in) from its seat.

Measure the valve stem deviation in two perpendicular directions and position the dial gauge as shown in the figure.

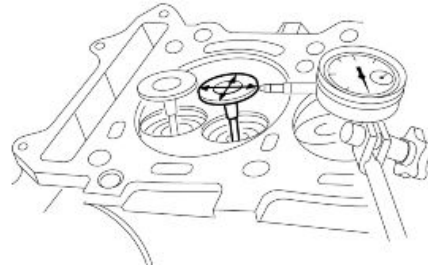

Characteristic

Valve stem distortion

0.25 mm (0.0098 in)

If the valve stem, when measured with a micrometer, is worn to its limit and the clearance exceeds the specified limit, replace the valve.

Recheck the clearance after replacing the valve.

Characteristic

Intake valve stem diameter

4.985 - 4.965 mm (0.1963 - 0.1954 in)

Exhaust valve stem diameter

4.975 - 4.955 mm (0.1959 - 0.1951 in)

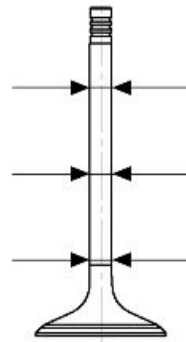

Support the valve with two "V" blocks as shown and check the run-out with a dial gauge.

If the run-out exceeds the specified limit, replace the valve.

Characteristic

Valve stem run-out

0.05 mm (0.0020 in)

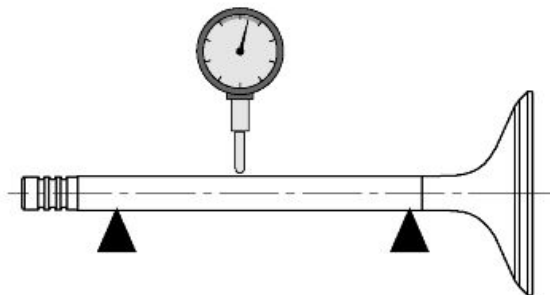

Position the dial gauge at a right angle to the valve head face and measure the eccentricity.

If the eccentricity exceeds the specified limit, replace the valve.

Characteristic

Valve head eccentricity

0.03 mm (0.0012 in)

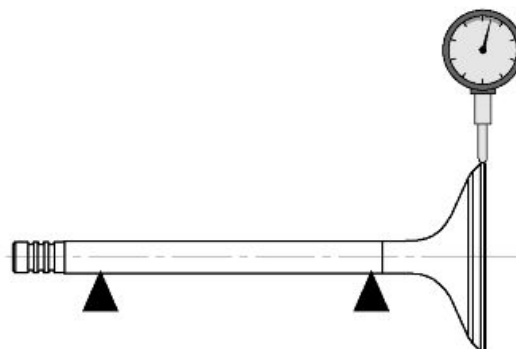

Coating may get slightly damaged in the indicated area.

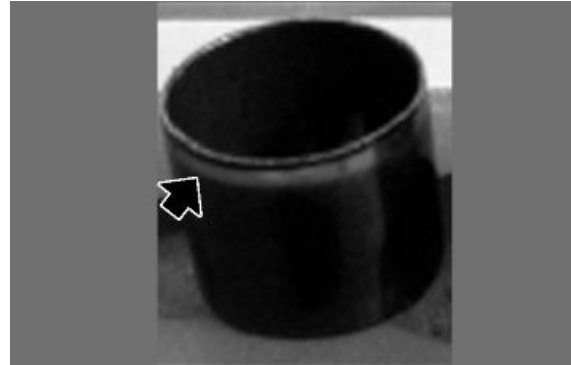

Valve installation

The intake valves are fitted with dual springs, while the exhaust valves only have a single spring. The intake springs are marked in orange (1) (external) and blue (2) (internal), whereas the exhaust springs (3) are marked in white.



- Lubricate the valve stem and insert the valves on the valve guide.



- Position the springs with the closest turns facing the head of the valve

CAUTION

THE INTAKE VALVES HAVE A DOUBLE SPRING WHEREAS THE EXHAUST VALVES HAVE A SINGLE SPRING.

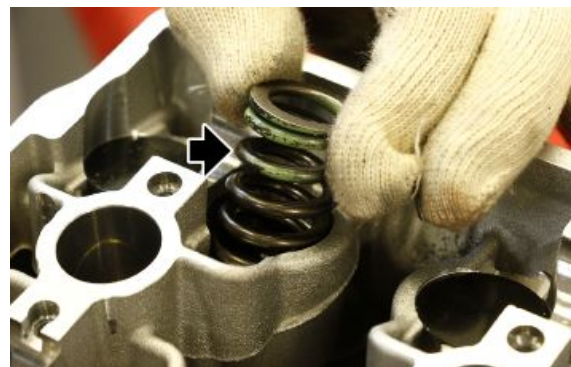

- Fit the caps.



- Compress the valve springs with the specific wrench and with the spring compressing tool.
- Insert the cotters into the seat



Specific tooling

AP8140179 Valve springs compressor

020853Y Compresses intake valve springs

020854Y Compresses exhaust valve springs

- Release the wrench, checking that the cotters are positioned correctly in the valve grooves.



- Position the adjusting shims



- Position the bucket tappets.



Crankcase

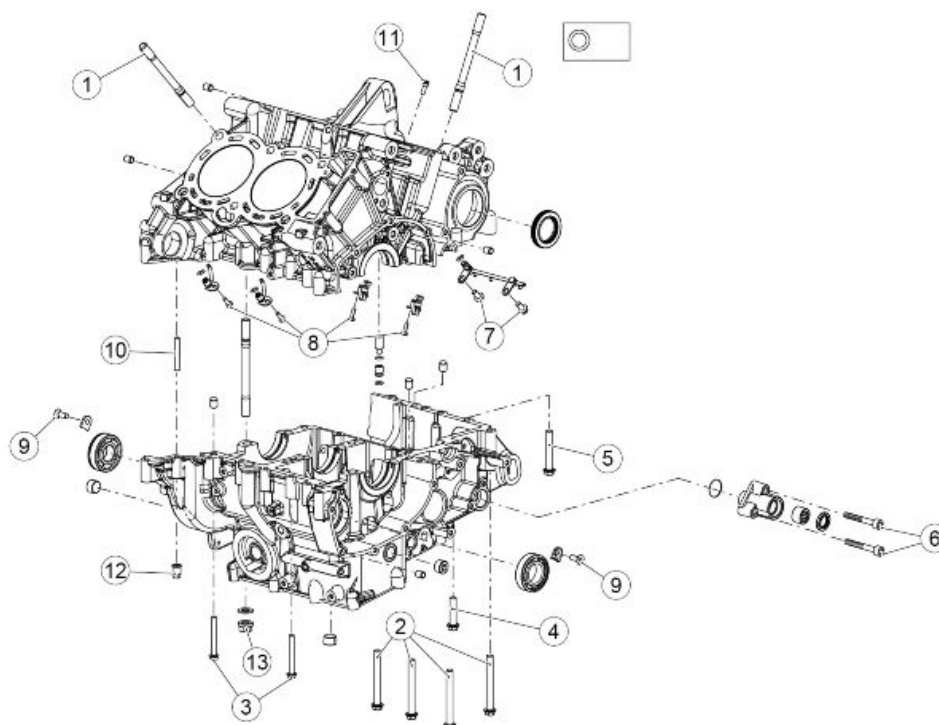

CRANKCASE

Pos.	Description	Type	Quantity	Torque	Notes
1	Stud bolts	M10	18	20 Nm (14.75 lb ft)	Loct. 270
2	TE Flanged screw	M8x70	4	25 Nm (18.44 lb ft)	Lubricate the head and under the head.
3	TE Flanged screw	M6x50	8	10 Nm (7.38 lb ft)	Lubricate the head and under the head.
4	TE Flanged screw	M8x35	1	25 Nm (18.44 lb ft)	Lubricate the head and under the head.
5	TE Flanged screw	M8x50	3	25 Nm (18.44 lb ft)	Lubricate the head and under the head.
6	Gearbox control rod support SHC fixing screws	M6x35	2	10 Nm (7.38 lb ft)	Lubricate the head and under the head.
7	Flanged TE screw fixing fuel rail gearbox lubrication	M6x12	2	10 Nm (7.38 lb ft)	Pre-impregnated screw and in absence Loct.2045
8	TB TORX screw	4x12	4	5 Nm (3.69 lb ft)	Pre-impregnated screw, in absence Loct.2045

Pos.	Description	Type	Quantity	Torque	Notes
9	TSPEI screw fixing bearing stop plates	M6x16	2	10 Nm (7.38 lb ft)	Loct. 243
10	Stud bolt	M6	1	Bring to 33mm from the surface	Loct. 648
11	SHC screw	M6x40	1	10 Nm (7.38 lb ft)	Lubricate the head and under the head.
12	Special nut	-	1	10 Nm (7.38 lb ft)	-
13	Flanged nut	M10	6	15 + 20 Nm (11.06 + 14.75 lb ft) + 60° + 60°	Lubricate the head and under the head. Use the sequence: 1) Pre-tighten to 15 Nm (11.06 lb ft); 2) Tighten to 20 Nm (14.75 lb ft); 3) Tighten applying an angle of 60° +/- 2; 4) Repeat the operation for another 60° +/- 2
-	Screw fastening ground cable to the engine	M6	2	6 Nm (4.43 lb ft)	-

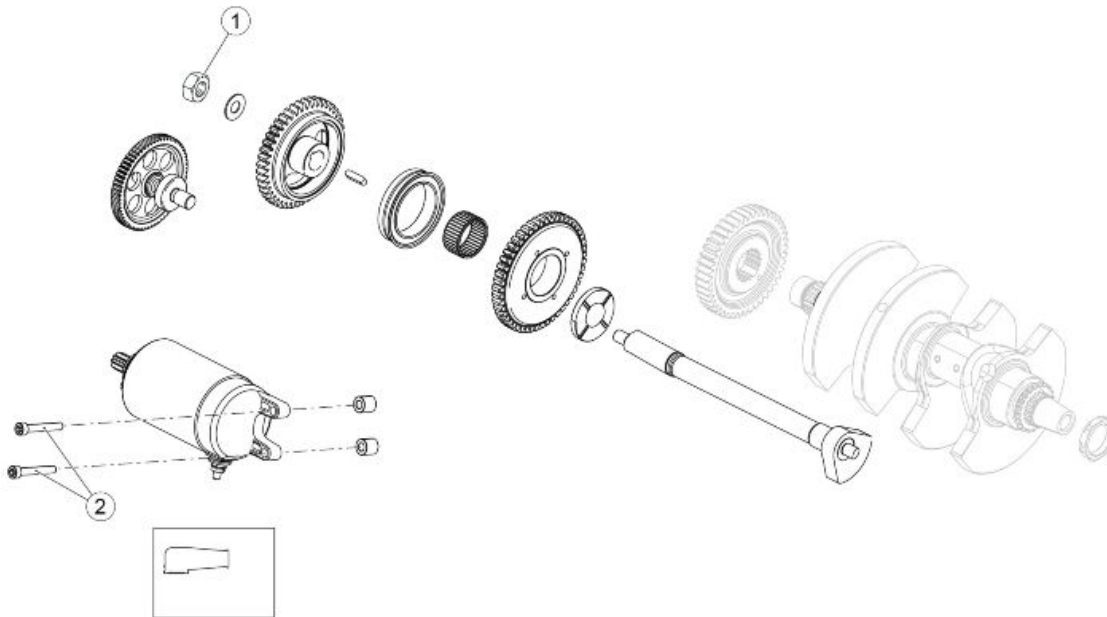

IGNITION UNIT

Pos.	Description	Type	Quantity	Torque	Notes
1	Hex headed nut cl.10 type 2 iso 8674	M10x1	1	50 Nm (36.88 lb ft)	Loct. 243
2	Starter motor SHC fastener screw	M6x40	2	10 Nm (7.38 lb ft)	-
-	Screw fastening cables to the starter motor	M6	1	6 Nm (4.43 lb ft)	-

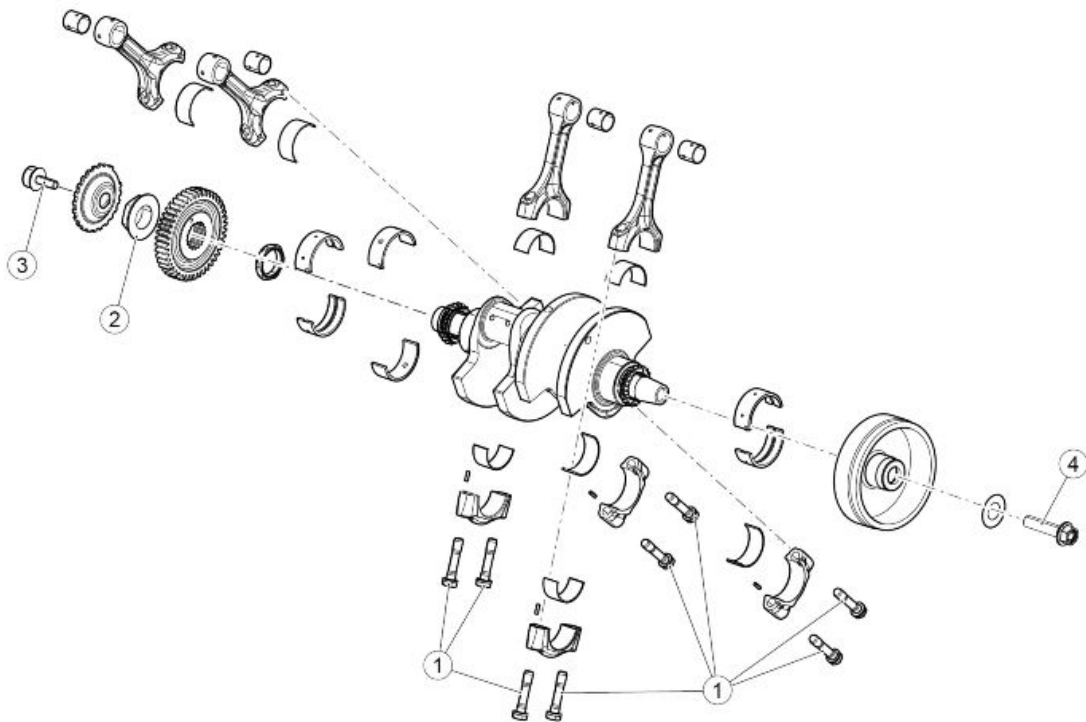

CRANKSHAFT

Pos.	Description	Type	Quantity	Torque	Notes
1	Connecting rod screws	-	8	15 + 20 Nm (11.06 + 14.75 lb ft) + 130°	Lubricate the head and under head with con PANKL Lubricant 01 (PLB01)
2	Primary fixing ring nut	-	1	200 Nm (147.51 lb ft)	Loct. 243
3	Tone wheel fastener screw	M8x24	1	50 Nm (36.88 lb ft)	Pre-impregnated, in absence Loct.270 or Loct.648
4	Generator fixing screw	M12x1.25	1	120 Nm (88.51 lb ft)	-

Balancing countershaft removal

- To extract the balancing countershaft, first remove: the clutch cover and the alternator cover.
- Turn the crankshaft so as to position the thicker side of countershaft gear on the side opposite to crankcase bulk-head.

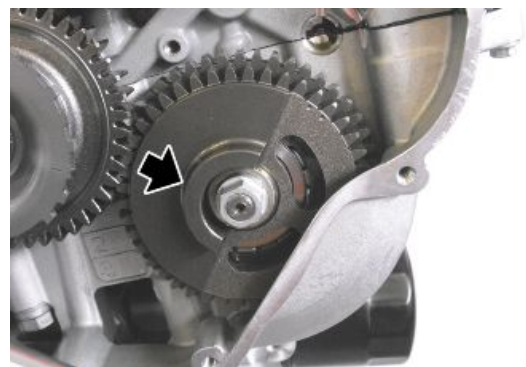

- Block crankshaft rotation using the specific tool.

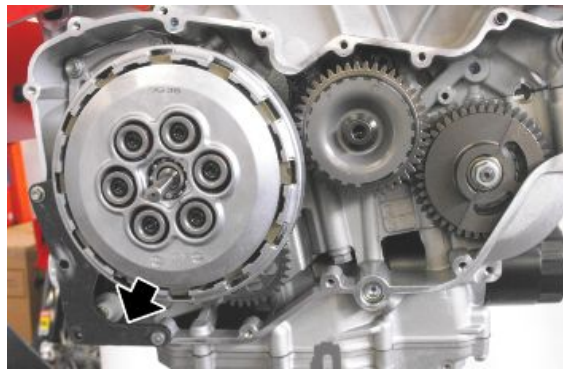
Specific tooling**020850Y Primary gear lock****See also**[Removing the clutch cover](#)[Removing the flywheel cover](#)

- Unscrew and remove the nut and collect the washer



- Remove the countershaft from the alternator side.



- Remove the countershaft gear.



- Remove the key on countershaft



- Remove the spacer.



- Remove the countershaft on the opposite side.



Balancing countershaft fitting

- Install the spacer.



THE SPACER CHAMFERED SIDE MUST BE FACING THE CRANKCASE.



- Install the countershaft gear aligning the references on the countershaft gear and the primary shaft gear.

NOTE

THE BURIN ON THE PRIMARY SHAFT GEAR TOOTH MUST BE INSERTED INTO THE SLOT IDENTIFIED WITH TWO BURINS ON THE COUNTERSHAFT GEAR.

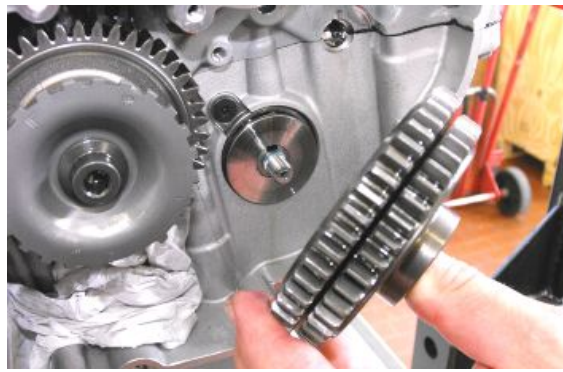

- Insert the countershaft from the alternator side.
- Turn the countershaft until aligning the key seat on the countershaft and on the gear.
- Insert the drive key.



- Place the washer.



- Turn the nut on the countershaft.
- Block crankshaft rotation using the specific tool.
- Tighten the nut on the countershaft.

Specific tooling

020849Y Clutch lock

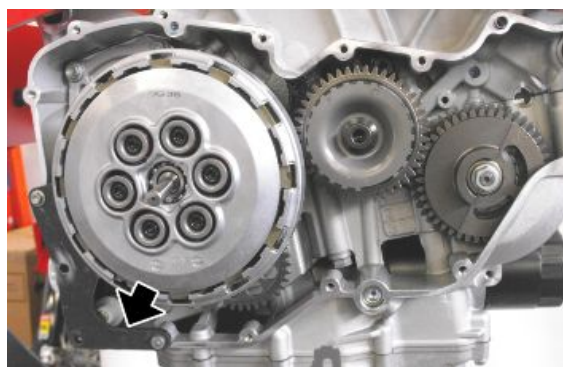

Main transmission gear removal

- Remove the clutch.
- Turn the crankshaft and align the references on the countershaft gear and the primary shaft gear.
- Block crankshaft rotation using the specific tool.

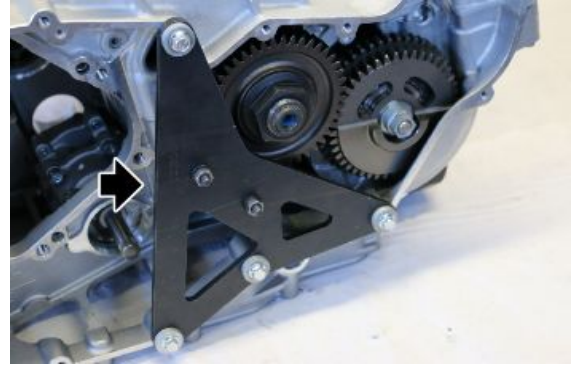

Specific tooling

020850Y Primary gear lock

- Unscrew and remove the tone wheel fixing screw.
- Remove the tone wheel.



- Unscrew and remove the primary shaft fixing nut.
- Remove the crankshaft blocking tool.

Specific tooling

020850Y Primary gear lock



- Remove the primary shaft gear.



Installing the primary drive gear

- Install the primary shaft gear correctly in its seat on the crankshaft from the clutch side.
- Make the references on the gears of the primary shaft and the countershaft coincide.

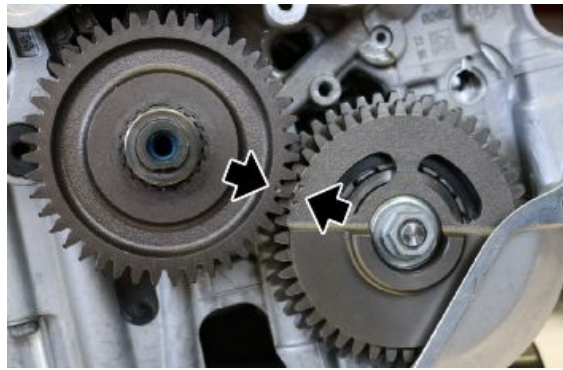

NOTE

THE BURIN ON THE PRIMARY SHAFT GEAR TOOTH MUST BE INSERTED INTO THE SLOT IDENTIFIED WITH TWO BURINS ON THE COUNTERSHAFT GEAR.

- Install the crankshaft blocking tool.
- Tighten the primary shaft fixing nut.

Specific tooling

020850Y Primary gear lock



- Insert the tone wheel on the crankshaft.

The crankshaft and the tone wheel have a bevel that identifies the fitting direction.

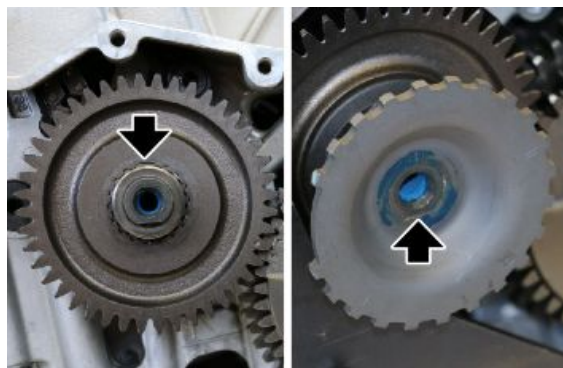

- Tighten the tone wheel fixing screw.
- Remove the special tool.

Specific tooling

020850Y Primary gear lock



Preparation

To open the crankcase, first remove the following components:

- alternator;
- water pump;
- gearbox unit;
- primary drive shaft gear
- both timing chains;
- the chain sliders;
- oil sump;
- the gear selector pin spacer;
- starter motor and intermediate gear;
- countershaft.

See also

Magneto flywheel removal

Water pump

[Disassembling the gearbox](#)

[Main](#)

transmission gear removal

Front head removal

Rear head removal

[Removing the](#)

oil sump

[Balancing](#)

countershaft removal

Crankcase opening

- Position the engine with the heads facing upward, unscrew and remove the screw (24).

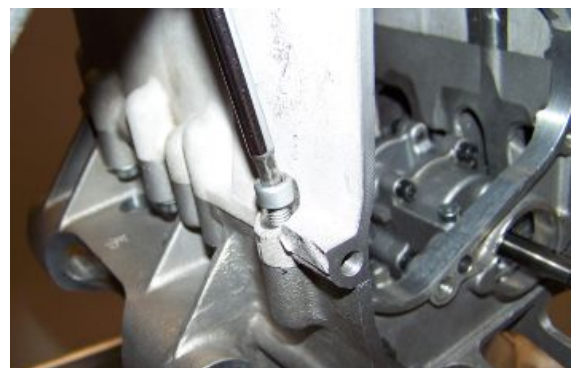

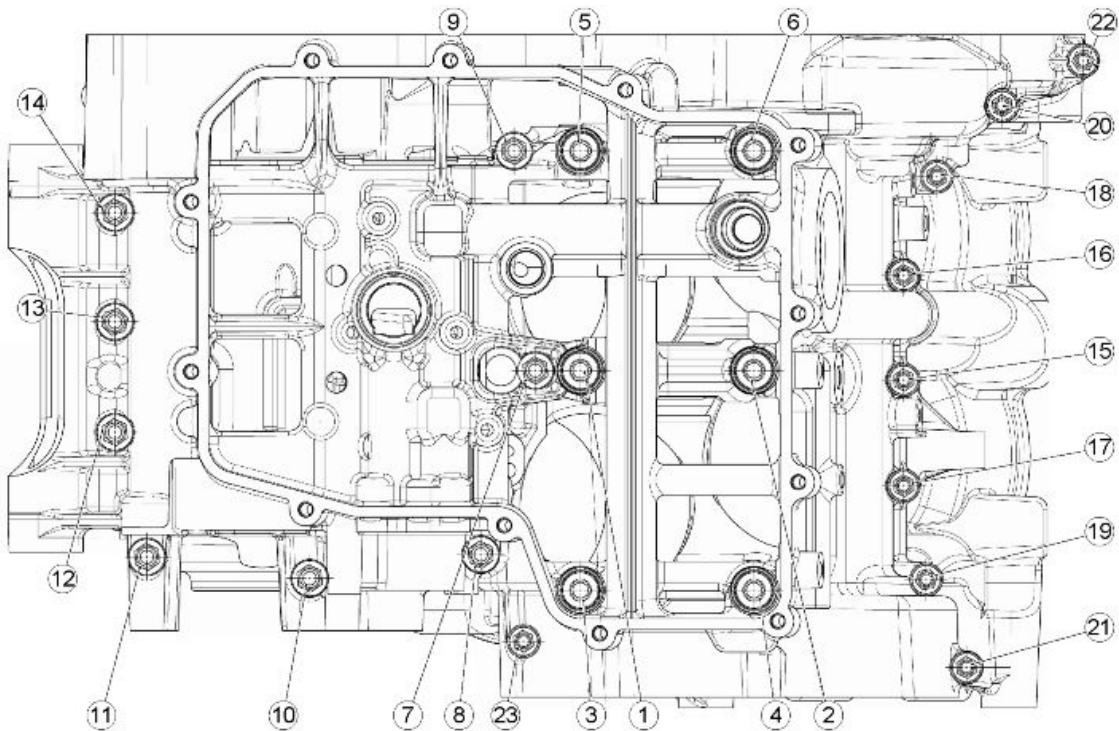

- Turn the engine with the heads facing downward and loosen the screws in the following order: 23 - 22 - 21 - 20 - 19 - 18 - 17 - 16 - 15 - 14 - 13 - 12 - 11 - 10 - 9 - 8 - 7.
- After loosening all screws, remove them in order indicated above.
- Loosen the six nuts on the stud bolts, proceeding in the following order 6 - 5 - 4 - 3 - 2 - 1.
- After loosening all nuts, remove them in order indicated above.

- Separate the crankcases, removing the lower part
- Collect the three dowel pins.
- The crankshaft, the pistons and the connecting rods remain in the upper crankcase.



Removing connecting rods - pistons

- Remove both heads.
- Open the crankcases.
- Install the tool that keeps the crankshaft in position.

Specific tooling

020857Y Crankshaft support U-bolt



See also

Front head removal

Rear head removal

- Unscrew and remove the two connecting rod screws.
- Remove the connecting rod cap.

NOTE

MARK THE COMPONENTS TO PREVENT INCORRECT RE-FITTING.



- Remove the piston connected to the connecting rod from the cylinder side.
- Take out the Seeger ring



- Slide off the pin



- Mark the piston crown on the exhaust side so as to remember the refitting position.
- Remove the piston.



Crankshaft removal

- Separate the crankcases, removing the lower part
- If the heads were removed, position the specific special tool to keep the pistons from coming out.

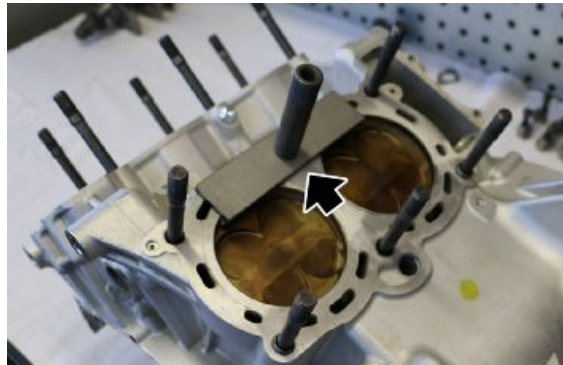

Specific tooling

020858Y Maintenance of the pistons in the cylinders

- Unscrew and remove the eight connecting rod screws.
- Remove the four connecting rod caps.

NOTE

MARK THE COMPONENTS TO PREVENT INCORRECT RE-FITTING.



- Take out the crankshaft.



Bearing removal

BALANCING COUNTERSHAFT BEARING REMOVAL

- Remove the lower crankcase.
- Remove the countershaft.

FLYWHEEL-SIDE

- Unscrew and remove the bearing retainer screw.
 - Remove the lock.
-
- Heat up the crankcase to 150°C (302° F).
 - Position the general tool to pull out bearings.
 - Remove the bearing.

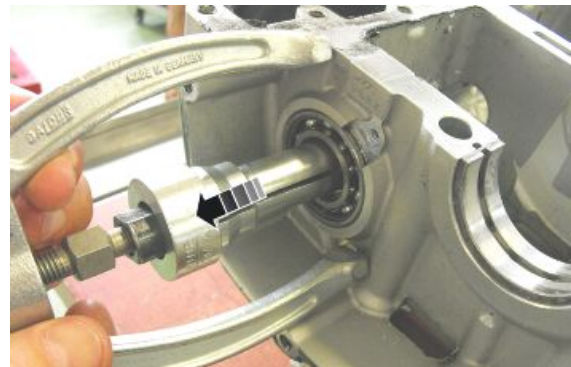

See also

Crankcase opening

CLUTCH-SIDE

- Unscrew and remove the bearing retainer screw.
- Remove the lock.



- Heat up the crankcase to 150°C (302° F).
- Position the general tool to pull out bearings.
- Remove the bearing.



Crankshaft check**Characteristic**

Maximum crankshaft axial clearance after closing the crankcase

0.40 - 0.10 mm (0.0157 - 0.0039 in)

Maximum radial play between main bushings and crankpins

0.07 mm (0.00275 in)



Balancing countershaft check**Characteristic**

Maximum countershaft axial clearance after closing the crankcase

0.1 mm (0.0039 in)

Connecting rod check

Characteristic

Maximum wear limit of the connecting rod small end

17.03 mm (0.6705 in)

Maximum connecting rod small end radial clearance

0.045 mm (0.0018 in)

Maximum radial play between connecting rod and crankpin

0.55 mm (0.022 in)

Maximum radial play of crankpin

0.08 mm (0.0031 in)



Inspecting pistons

PISTON-CYLINDER COUPLING

	Selection A	B Selection
Cylinder	77.998 - 78.006 mm	78.006 - 78.014 mm
Piston	77.948 - 77.958 mm	77.958 - 77.968 mm
Coupling clearance	0.040 - 0.058 mm	0.038 - 0.056 mm

CAUTION

THE MEASUREMENT OF THE PISTON DIAMETER IS PERFORMED AT 6 mm (0.24 in) FROM ITS BASE

Characteristic

Coupling clearance between the pin and the hole on the piston

0.016 - 0.005 mm (0.0006 - 0.0002 in)

Aperture tolerance of the first piston ring mounted on the cylinder

0.10 - 0.25 mm (0.0039 - 0.0098 in)

Aperture tolerance of the second piston ring mounted on the cylinder

0.40 - 0.60 mm (0.0157 - 0.0236 in)

Aperture tolerance of the third piston ring (oil scraper) mounted on the cylinder

0.20 - 0.70 mm (0.0079 - 0.0276 in)



Selecting connecting rods

SELECTING CRANKSHAFTS AND CONNECTING RODS ACCORDING TO BALANCING CLASS

crankshafts and connecting rods have been introduced which are matched with each other in relation to their balancing class. The class is easily identifiable as it is marked on the component itself.

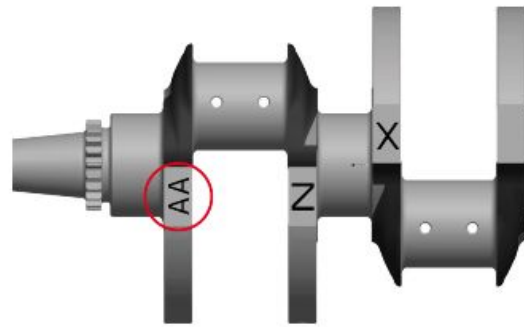

The permitted crankshaft-connecting rod balancing class combinations are listed in the following table:

CRANKSHAFT - CONNECTING ROD BALANCING CLASSES

Crankshaft balancing classes	Combinations of weight classes for connecting rod pair on alternator side	Combinations of weight classes for connecting rod pair on primary drive side
AA	AA+AA	AA+AA
BB	BB+BB / **AA+CC**	BB+BB / **AA+CC**
CC	CC+CC / **BB+DD**	CC+CC/**DD+BB**
DD	DD+DD / **CC+EE**	DD+DD/**EE+CC**
EE	EE+EE	EE+EE

The connecting rod class is stamped on its left side, viewed from the front, from the side with the bevelling on the big end hole.

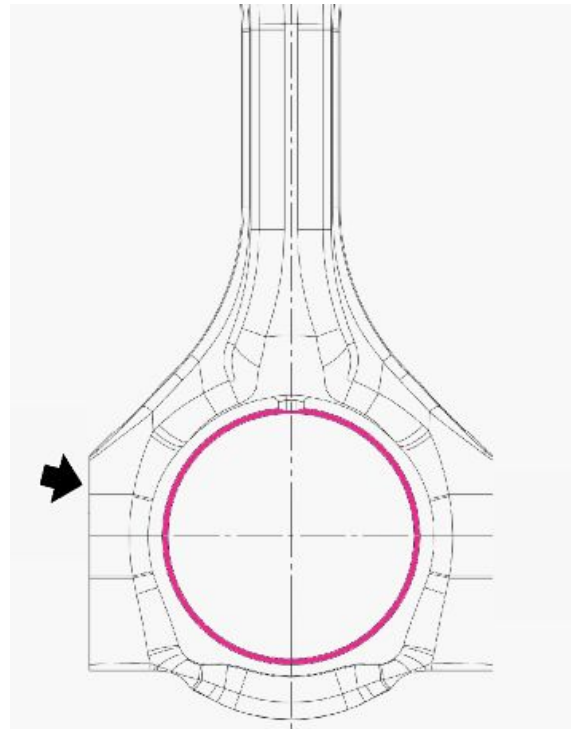

Bushing selection

CRANKSHAFT BUSHINGS

CRANKCASE CATEGORY

Three crankcase classes are available (A - B- C) which differentiate in the diameter of the hole in the bearings.

The category is marked on the crankcase, on the right side, in the area below the gearbox.

Different classes of bearings can be used (e.g.: A - B - C or B - B - C or A - B - A).



A number that indicates the position of the main journal is stamped on the crankcase:

1. flywheel side;
2. central;
3. clutch side.



CRANKCASE CATEGORY

Specification	Desc./Quantity
Class A	Bushing seat diameter 52.023 - 52.018 mm (2.0481 - 2.0479 in)
Class B	Bushing seat diameter 52.018 - 52.013 mm (2.0479 - 2.0477 in)
Class C	Bushing seat diameter 52.013 - 52.008 mm (2.0477 - 2.0475 in)

SHAFT CATEGORY

The category of the three crankshaft main journals is stamped on the flat face of the counterweight, as shown in the image.

The three main journals may be of different classes.

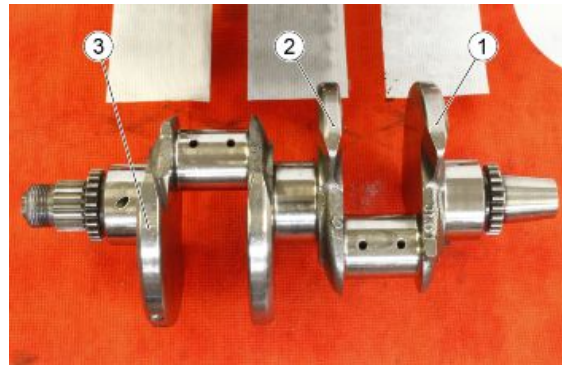

CRANKSHAFT CATEGORIES

Specification	Desc./Quantity
Class C	Main journals - diameter: 46.028 - 46.023 mm (1.8121 - 1.8119 in)
Class D	Main journals - diameter: 46.023 - 46.018 mm (1.8119 - 1.8117 in)
Class E	Main journals - diameter: 46.018 - 46.013 mm (1.8117 - 1.8115 in)

Once the categories below are checked:

1. crankcase;
2. flywheel side main journal;
3. centre main journal;
4. clutch side main journal.

Choose the bushings used for assembly from the following table

CRANKSHAFT BUSHINGS

Crankshaft main journal	Class A crankcase	Class B crankcase	Class C crankcase
Class C main journal	Bushing (green)	Bushing (green)	Bushing (yellow)
Class D main journal	Bushing (black)	Bushing (green)	Bushing (green)
Class E main journal	Bushing (black)	Bushing (black)	Bushing (green)

The flywheel side and clutch side main bearings are different from the central ones and therefore, so are the respective replacement part numbers.

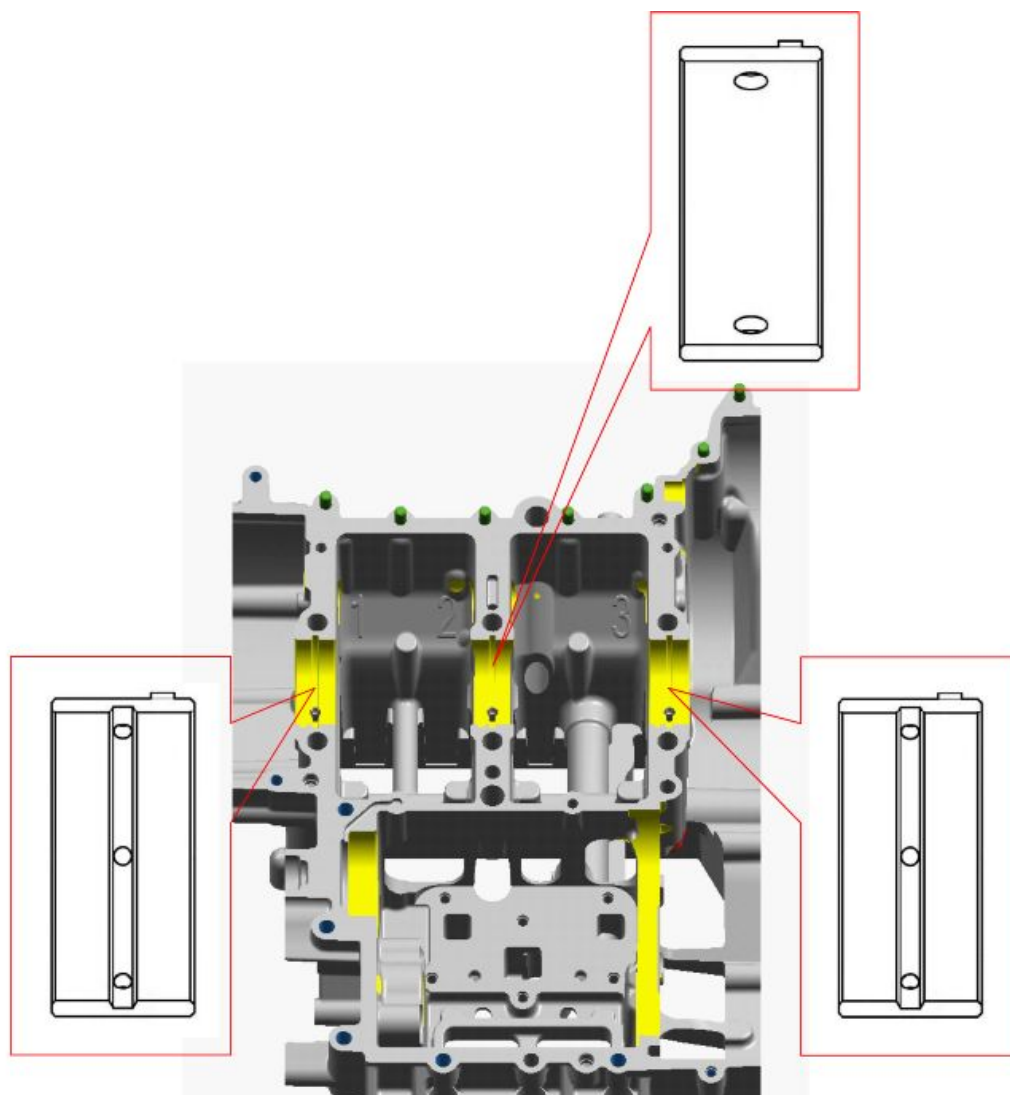

CRANKSHAFT BUSHINGS - CONNECTING RODS

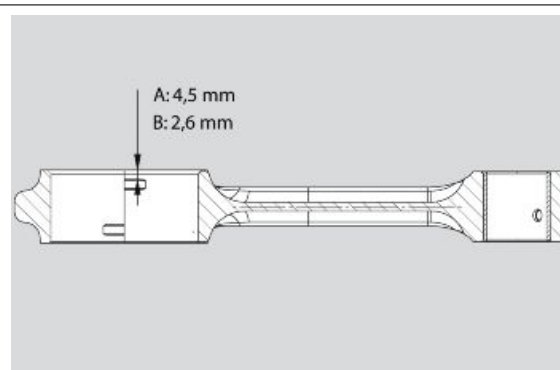

Three types of semi-bushing are available for the connecting rods:

- Blue
- Yellow
- Green

For the coupling of the connecting rod with the crankshaft, according to the engraving on the counterweights, observe the following table:

BUSHINGS THICKNESS

Bushing colours	Thickness
BLUE	1.547 - 1.552 mm
YELLOW	1.552 - 1.557 mm
GREEN	1.557 - 1.562 mm

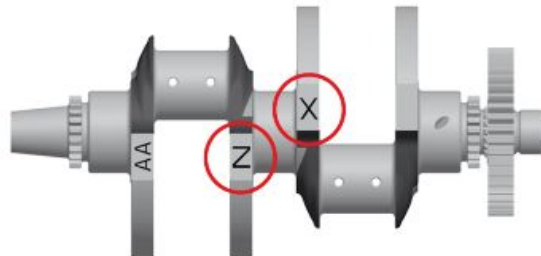

CONNECTING RODS COUPLING - CRANKSHAFT

Selection connecting rod pin dimension	Big end class 1	Big end class 2	Required clearances class 1	Required clearances class 2
X (35.885 - 35.880 mm)	Blue + Yellow (1)	Yellow + Yellow	0.053 - 0.026 mm	0.053 - 0.027 mm
Y (35.880 - 35.874 mm)	Yellow + Yellow	Yellow + Green (1)	0.054 - 0.026 mm	0.054 - 0.027 mm
Z (35.874 - 35.869 mm)	Yellow + Green (1)	Green + Green	0.054 - 0.027 mm	0.054 - 0.028 mm

Key:

(1) If using bushing of different thickness, install the thickest on the side of the connecting rod shank

BIG END BUSHING REPLACEMENT PROCEDURE

When replacing the big end bushings, make sure that the tang of the semi-bushing is correctly housed in the corresponding notch in the connecting rod stem or cap.

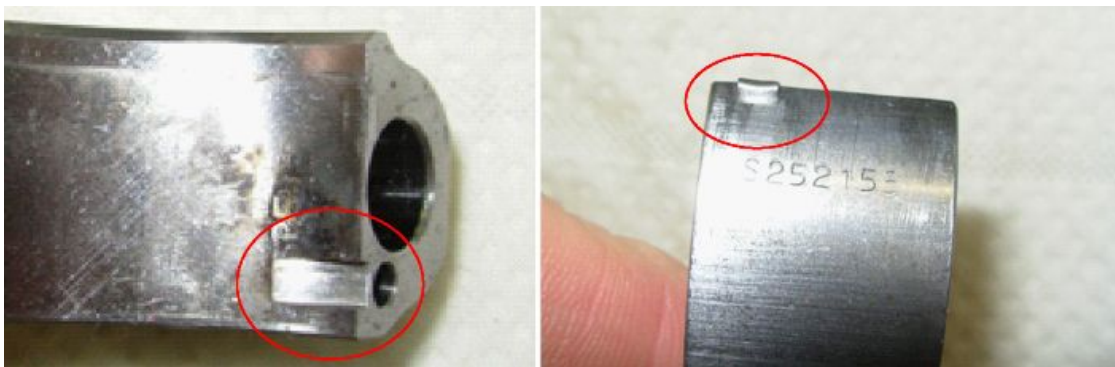

Bearing fitting

BALANCING COUNTERSHAFT BEARING INSTALLATION

FLYWHEEL-SIDE

- Heat up the crankcase to 150°C (302°F).
- Prepare the following tools:

Specific tooling

020364Y 25 mm adapter

020359Y 42 x 47 mm punch

020376Y Sleeve for adaptors

- Position the new bearing with its groove on the outside diameter facing outward with respect to the crankcase. In this way it will be possible to install the bearing retainer in the groove.



-
- Using the suitable tools, fit the bearing in the crankcase until tool stops



-
- Fit the retainer in the bearing groove.
 - Tighten the bearing retainer screw.



CLUTCH-SIDE

- Heat up the crankcase to 150°C (302°F).
- Prepare the following tools:

Specific tooling

020363Y 20 mm diam. punch for crankshaft oil seal

020359Y 42 x 47 mm punch

020376Y Sleeve for adaptors

- Position the new bearings with their groove on the outside diameter facing outward with respect to the crankcase. In this way it will be possible to install the bearing retainer in the groove.



- Using the suitable tools, fit the bearing in the crankcase until tool stops.



- Fit the retainer in the bearing groove.
- Tighten the bearing retainer screw.
- Install the balancing countershaft.



Crankshaft fitting

When refitting the primary gear, remember to first place the lining as shown in the figure. The greater diameter side is facing outwards the engine.



- Lubricate the crankshaft pins and insert them into their positions.



- Install the connecting rod shank piston assembly in the relative cylinders.
- Join the crankcases.
- If the special tool was used, remove it to keep the pistons from coming out.

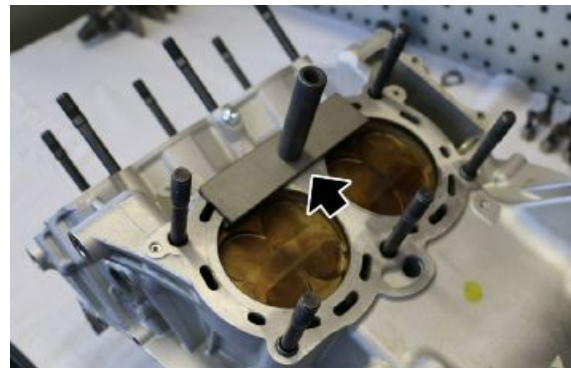

Specific tooling

020858Y Maintenance of the pistons in the cylinders

- Install the primary shaft gear correctly in its seat on the crankshaft from the clutch side.
- Make the references on the gears of the primary shaft and the countershaft coincide.

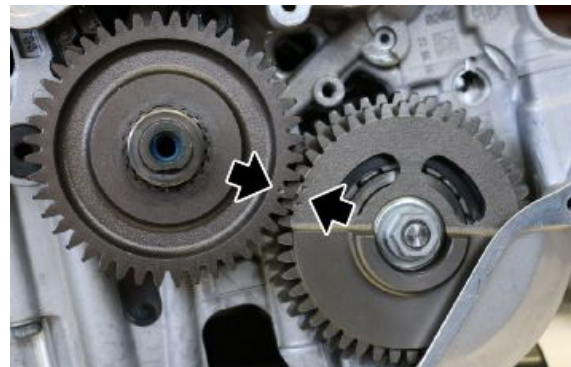

NOTE

THE BURIN ON THE PRIMARY SHAFT GEAR TOOTH MUST BE INSERTED INTO THE SLOT IDENTIFIED WITH TWO BURINS ON THE COUNTERSHAFT GEAR.

- Install the crankshaft blocking tool.
- Tighten the primary shaft fixing nut.



Specific tooling

020850Y Primary gear lock

- Insert the tone wheel on the crankshaft.

The crankshaft and the tone wheel have a bevel that identifies the fitting direction.

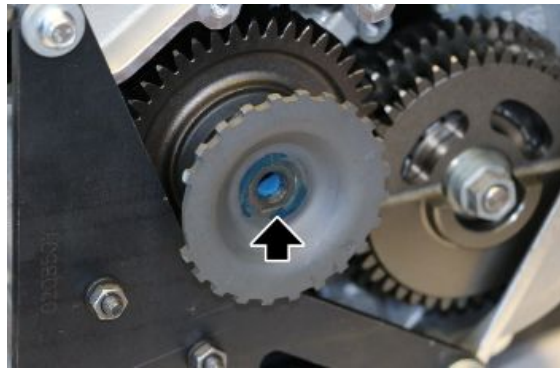

- Tighten the tone wheel fixing screw.
- Remove the special tool.

Specific tooling

020850Y Primary gear lock



Installing connecting rods - pistons

The piston rings are different and must be fitted with the "KDN5" markings (for the upper one)(A) and "K-TOP and KDN5" markings (for the lower one)(B) facing upward.



The five ring gaps (two piston rings, two oil scraper rings, one oil scraper spring) are fitted displaced 90° to each other, starting from the exhaust-side stud bolt opposite the chain and continuing clockwise.

The fitted pistons have two selections A and B. Therefore they are coupled with the cylinder according to the selection of the latter, which is marked on the upper crankcase halves.

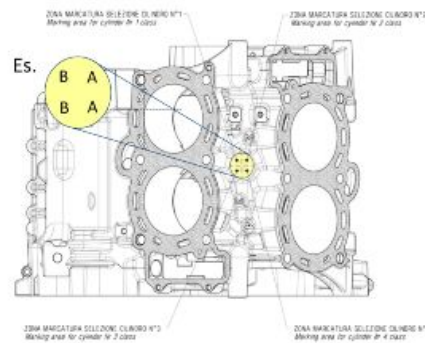

Pre-assemble the pistons on the workbench with the connecting rod shank and the relative semi-bushing.

The pre-assembly procedure is identical for all four pistons and must be done as follows:

- with the piston crown parallel to the workbench and the arrow (1) positioned from the side opposite of the operator, fit the connecting rod shank with the bevelling (2), on the hole of the rod head, on the right side.

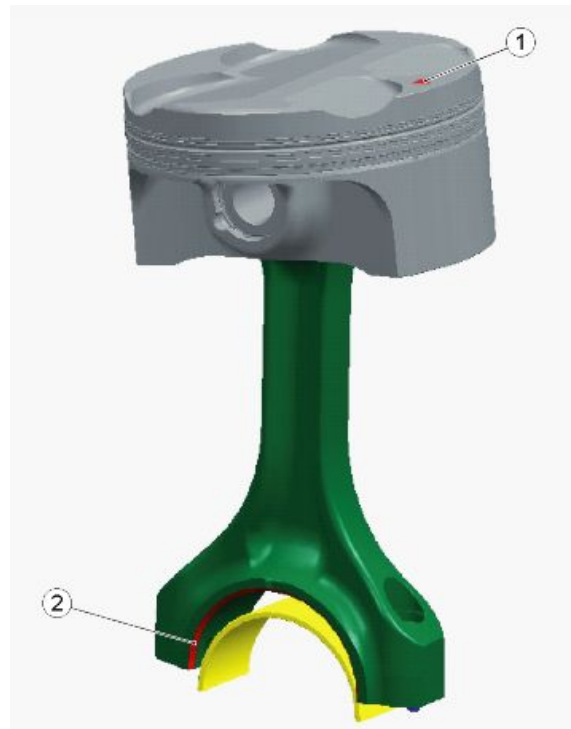

- Position the special tool on the crankcase.
- Partially insert the connecting rod shank - piston assembly in the corresponding cylinder with the arrow (on the piston) twisted 45° towards the exhaust.
- When the connecting rod head is low, and has exceed its lubricating jet, rotate the connecting rod shank - piston assembly with the arrow on the piston crown towards the exhaust; the beveling on the connecting rod head must face outward of its crank pin.



Specific tooling

020856Y Piston assembly ring

- Remember to couple the connecting rod shank and cap correctly, combining the respective numerical references.
- Use new connecting rod screws, lubricating the thread and under the head..



- Proceed with tightening according to the procedure described in the tightening torque table using the torque wrench and angular tightening with a goniometer.



Crankcase closing

- Insert the crankshaft together with connecting rods and pistons in the upper crankcase.
- Position the three centring dowels in the crankcase.
- Insert a new oil seal O ring in the specific seat.



- Insert the maximum pressure valve in the crankcase, composed of two separate parts





- Apply a layer of sealing paste along the external edge of the crankcase.
- Join the two crankcases.

Recommended products

Three bond Sealing paste

-



- Pretighten the six nuts on the stud bolts proceeding in the following order: 1 - 2 - 3 - 4 - 5 - 6.
- Then tighten them fully following the same order.
- Pre-tighten the screws in the following order: 7 - 8 - 9 - 10 - 11 - 12 - 13 - 14 - 15 - 16 - 17 - 18 - 19 - 20 - 21 - 22 - 23.
- Then tighten them fully following the same order.

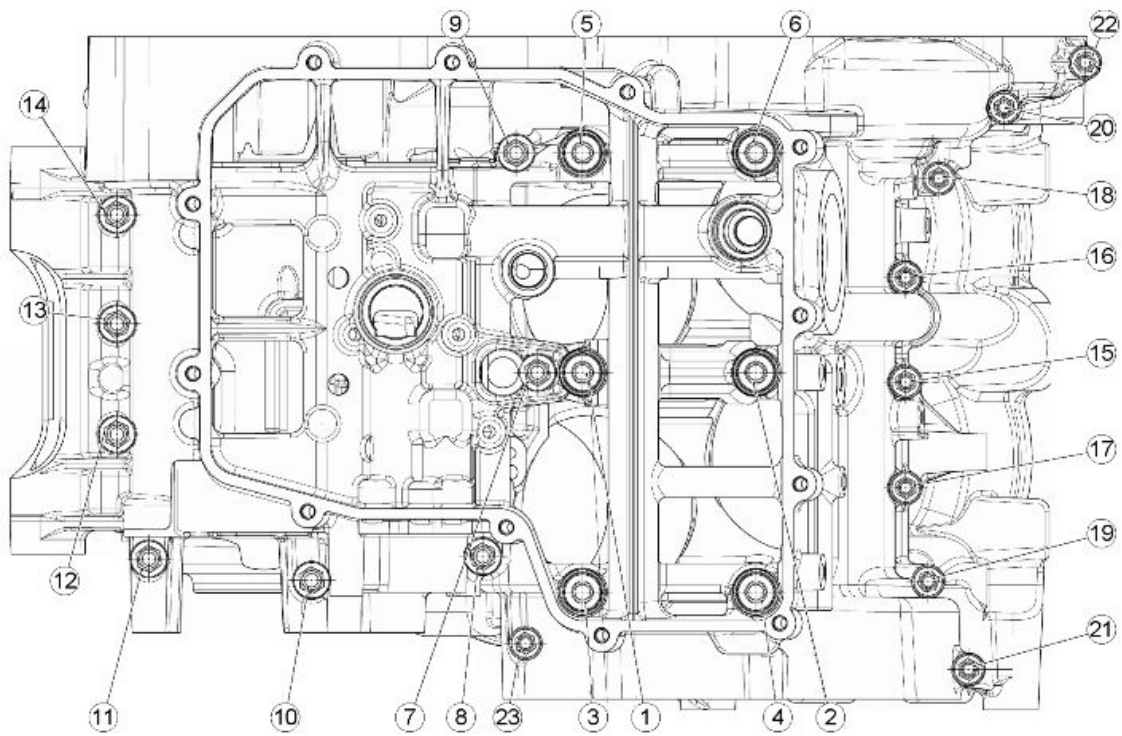

- Turn the engine with the heads facing upward.
- Tighten the screw (24).

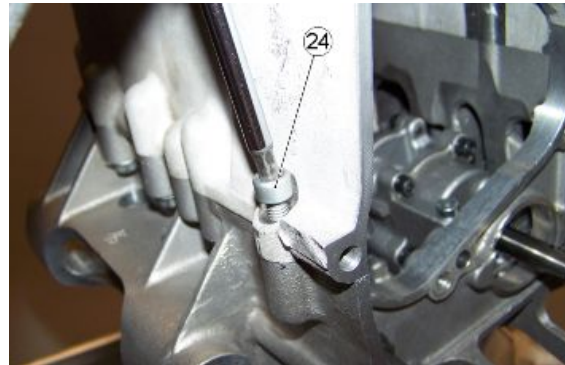

Thermal group

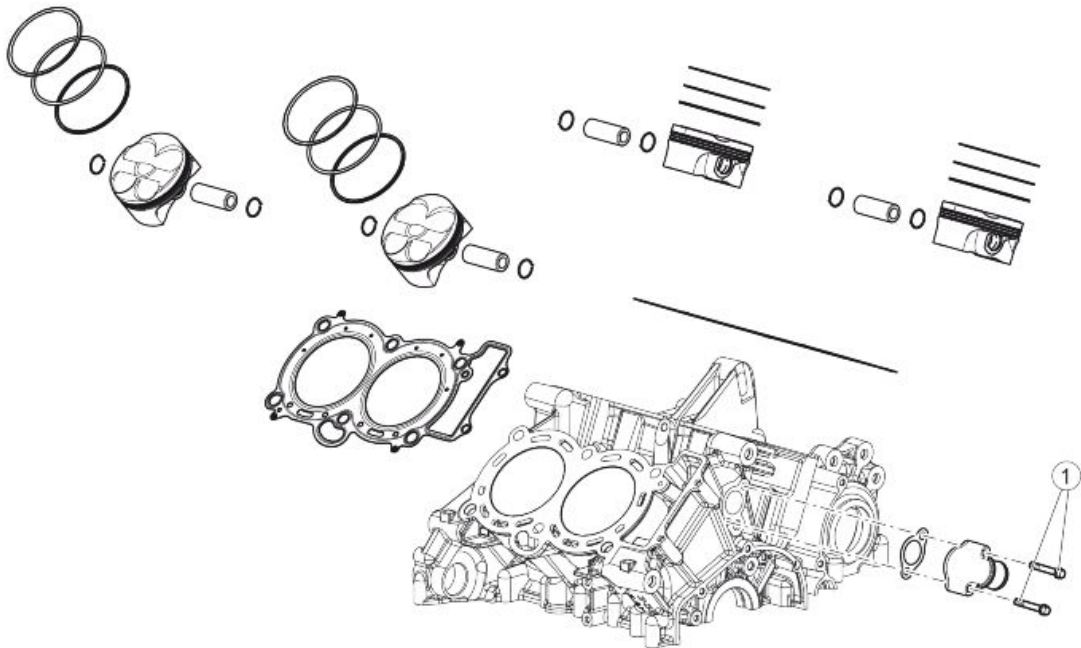

CYLINDERS - PISTON

pos.	Description	Type	Quantity	Torque	Notes
1	Screws fastening water union onto crankcase	M6x40	2	10 Nm (7.38 lb ft)	-

Lubrication

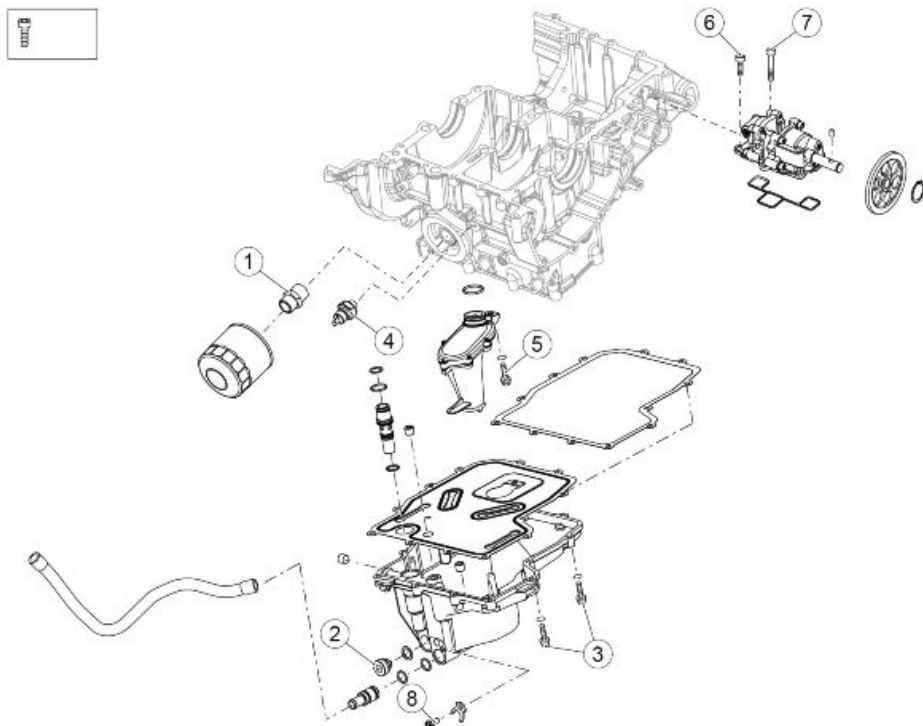

LUBRICATION SYSTEM

Pos.	Description	Type	Quantity	Torque	Notes
1	Oil filter coupling fastening screw	-	1	30 Nm (22.13 lb ft)	-
2	Oil drainage plug	-	1	30 Nm (22.13 lb ft)	-
3	Oil sump fixing screws	M6x30	12	12 Nm (8.85 lb ft)	Tighten to torque, unscrew and re-tighten to torque.
4	Oil pressure sensor	-	1	15 Nm (11.06 lb ft)	-
5	Flanged TE rose pipe fastening screw	M6x16	1	10 Nm (7.38 lb ft)	Pre-impregnated screw, in absence Loct.2045
6	SHC screw fixing pump to the casing	M6x16	5	10 Nm (7.38 lb ft)	-
7	SHC screw fixing pump to the casing	M6x50	1	10 Nm (7.38 lb ft)	-
8	SHC screw fixing oil pipe connection	M6x20	1	10 Nm (7.38 lb ft)	-

Oil pump**Removing**

- Remove the gearbox.
- Remove the water pump.
- Unscrew and remove the six screws fastening the oil pump to the crank-case.
- Remove the oil pumps.

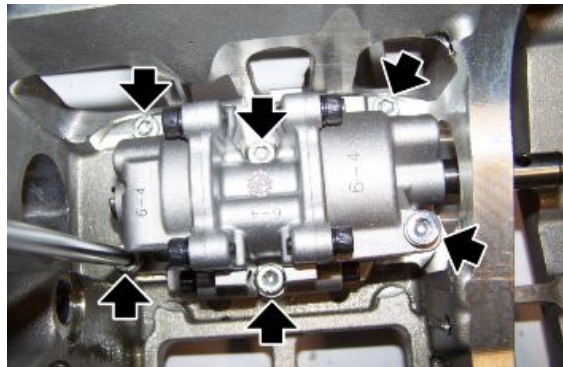
**OIL PUMP REMOVAL**

- Place the oil pumps on a work table.
- Remove the gasket.

**See also**

[Removing the gearbox](#)

Water pump

- Unscrew and remove the four cooling oil pump cover screws

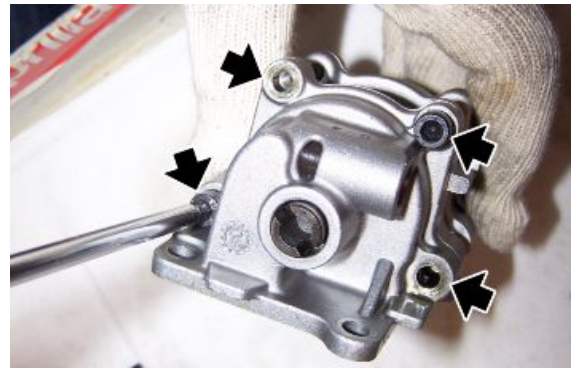

- Remove the cooling oil pump cover.
- Collect the two dowel pins.
- Remove the external rotor from the cover.



- Remove the internal oil cooling rotor.
- Collect the hitch pin.



- Unscrew and remove the four lubrication oil pump cover screws.



- Remove the lubrication oil pump cover and the intermediate pump casing from the shaft.
- Collect the two dowel pins.

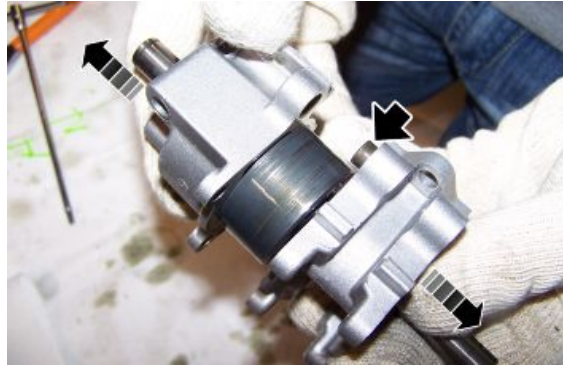

- Remove the external lubrication rotor.



- Remove the internal oil lubrication rotor
- Collect the drive spindle.



Installing

- Position the lubrication pump internal rotor on the oil pump control shaft

The lubrication pump components are larger than the cooling pump components.

The lubrication pump must be fit onto the shaft from the side with the Seeger ring seat for fastening the gear.

- Install the drive spindle on the shaft.



- Position the external rotor on the lubrication pump's internal rotor.

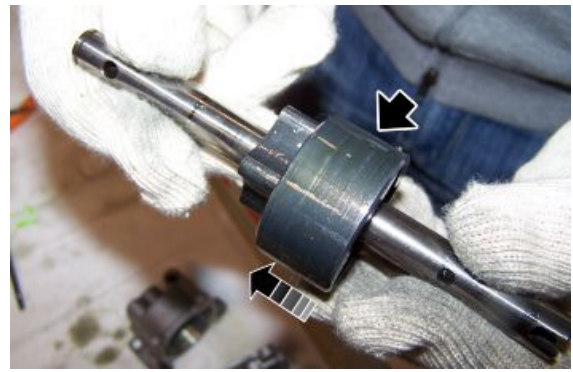

- Position the dowel pins.
- Position the pump cover and the intermediate pump casing on the lubrication pump's external rotor.

To check that the intermediate casing is oriented correctly, check the gasket seat.



- Tighten the four lubrication oil pump cover screws.



- Position the hitch pin on the oil pump control shaft.
- Position the oil cooling pump's internal rotor.



- Position the dowel pins and the external rotor on the cooling oil pump cover.
- Fit the pump cover on the internal rotor.



- Tighten the four cooling oil pump cover screws.
- Fit a new gasket.

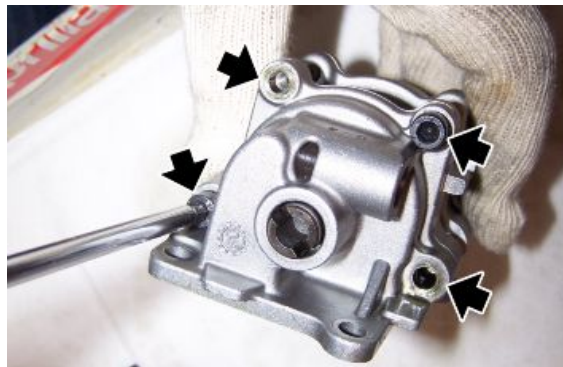

Removing the oil sump

- Drain the engine oil.
- Unscrew and remove the twelve oil sump screws.

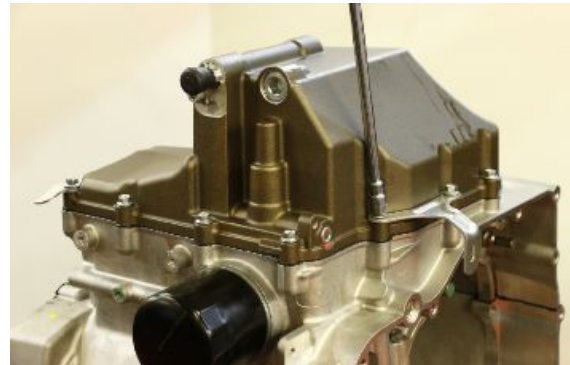

- Remove the oil sump



- Remove the upper gasket

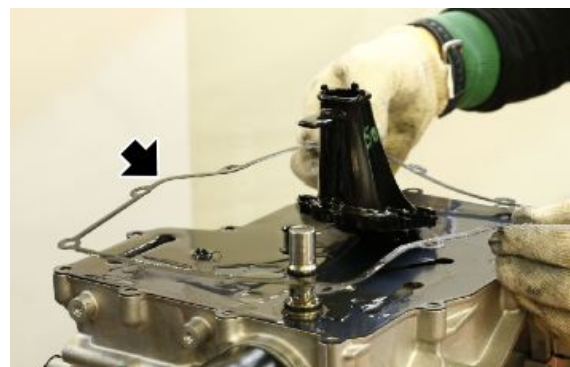

- Remove the rose pipe together with the gasket

CAUTION



THE ROSE PIPE MUST BE CAREFULLY CLEANED IN THE EVENT THAT THE ENGINE IS COMPLETELY OVERHAULED OR IN CASE OF PROBLEM WHICH MAY HAVE GENERATED SUSPENDED DEBRIS IN THE OIL.



DURING REFITTING REPLACE THE GASKET WITH A NEW ONE OF THE SAME TYPE.

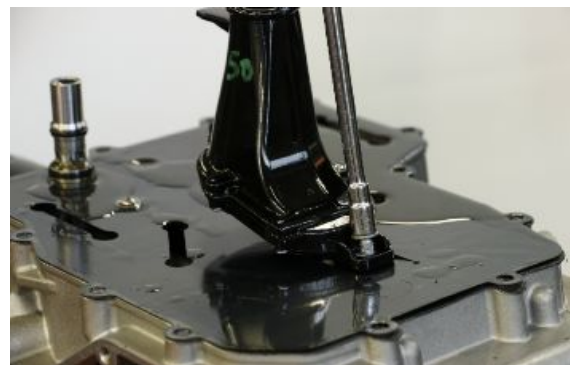

- Remove the metal gasket central fixing screw

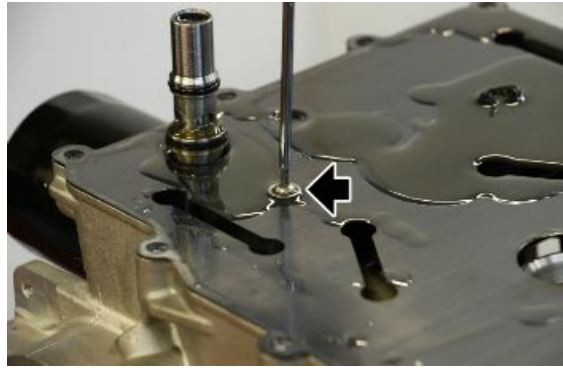

- Remove the metal gasket



- Remove the lower gasket



- Remove the overpressure valve together with gasket

Blow-by

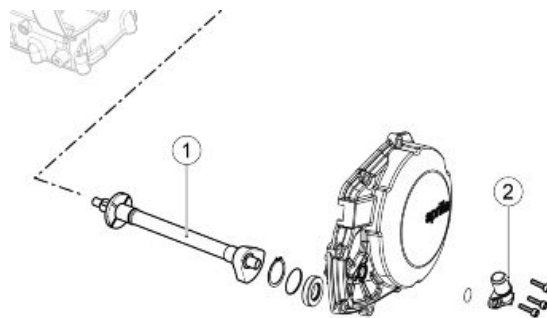

The Blow-by system uses the rotation of the countershaft (1) to separate the engine oil into oil vapour and liquid.

The oil vapours exit from the fitting (2) on the alternator cover and enter the air filter box whereas the liquid returns to the oil sump.

SAS valve

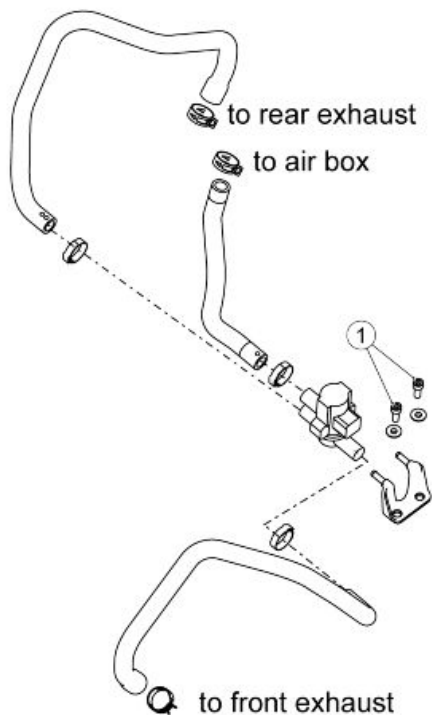

SECONDARY AIR SYSTEM

Pos.	Description	Type	Quantity	Torque	Notes
1	Cylindrical head, hex. socket secondary air solenoid screws	M6x16	2	10 Nm (7.38 lb ft)	-

Diagram

Valve controlled by control unit which delivers aspirated air from the filter box to the exhaust manifolds.

The advantages of this function are twofold:

- the catalytic converter reaches the operating temperature more quickly;
- it permits the use of richer mixtures in some critical conditions (e.g. at idle or low engine speeds).

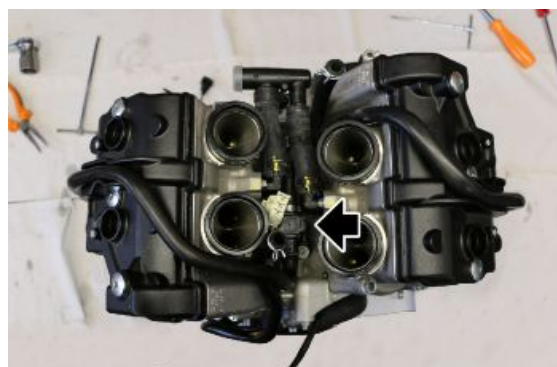

Inspecting the one-way valve

- Unscrew and remove the three screws.



- Remove the cover together with the two secondary air system valves.



INDEX OF TOPICS

POWER SUPPLY

P SUPP

Fuel pump

Removing

- Remove and empty the fuel tank.
- Remove the pipe grommet.



- Disconnect the fuel pipe from the fuel pump



- Unscrew and remove the six fixing screws of the fuel pump

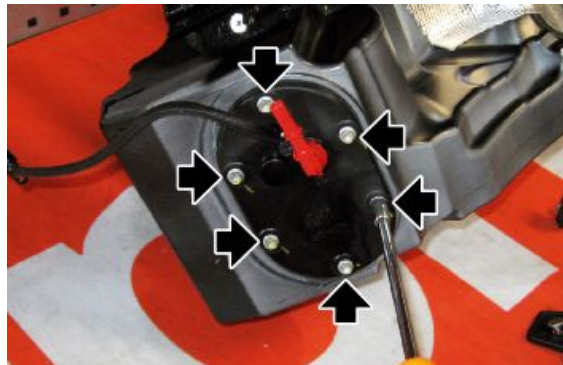

- Remove the fuel pump



Injection

Diagram

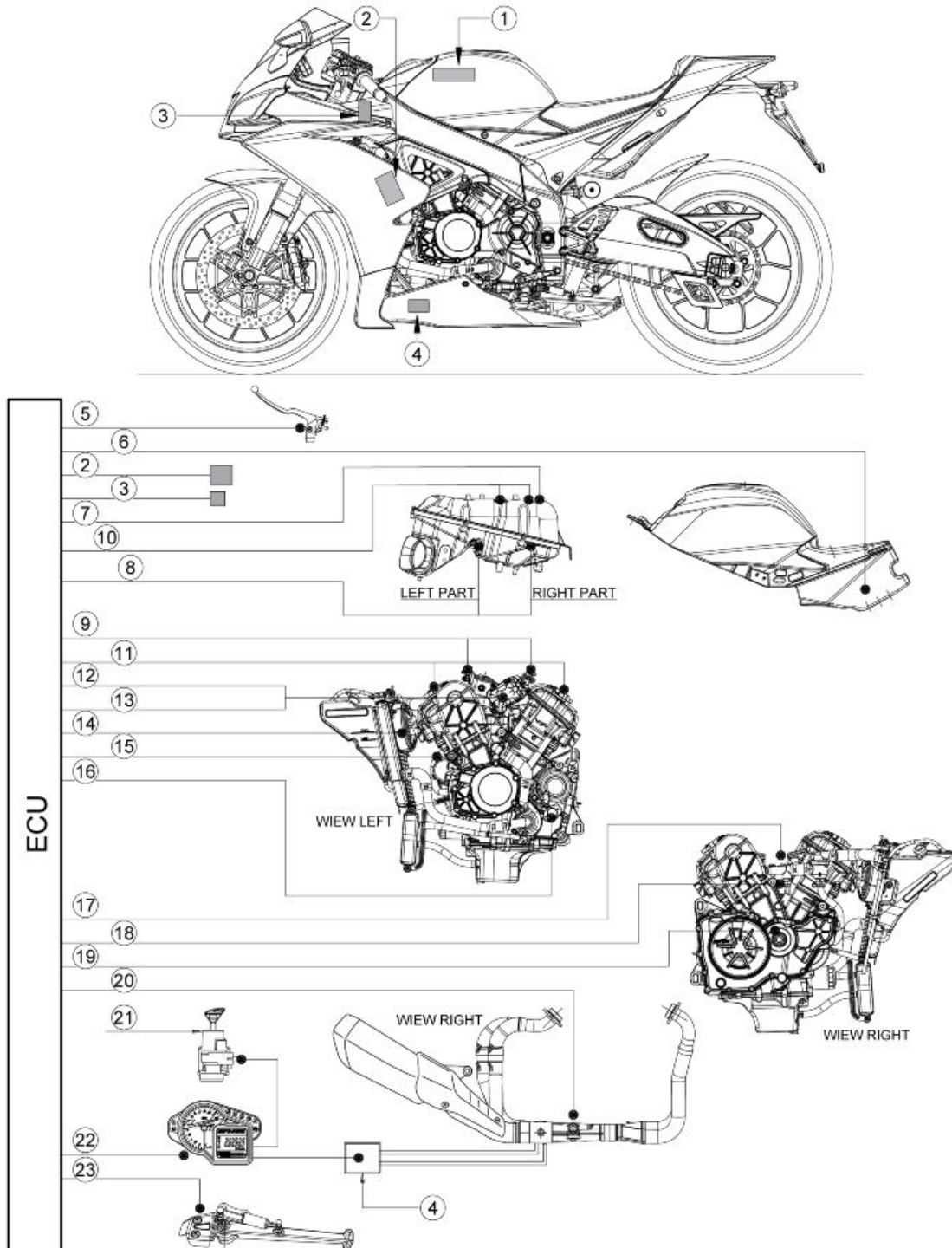

key:

- 1. Control unit position
- 2. Throttle grip position sensor

3. Fall sensor
 4. Exhaust valve
 5. Clutch position sensor
 6. Fuel pump (inside the tank)
 7. Air temperature sensor
 8. Air pressure sensor (MAP)
 9. Lower injectors
 10. Upper injectors
 11. Coils (spark plug cover)
 12. Engine throttle valves
 13. Throttle valve position sensor
 14. Electric fan
 15. Starter motor
 16. Gear position sensor
 17. Secondary air injection valve
 18. Coolant temperature sensor
 19. Crankshaft position sensor
 20. Lambda probe
 21. Ignition switch
 22. Instrument panel
 23. Side stand sensor
-

Ride by Wire

Operating logic

Those riding motorbikes do not require a specific throttle valve opening from their engines but actually a specific torque. The Ride by Wire system has been so designed that the throttles of the throttle bodies are mechanically isolated from the throttle control; their actuation depends exclusively on 2 electrical motors controlled by the control unit. The control unit refers to specific handle maps to determine by how much and how quickly the throttle valves are opened. The parameters influencing the handle map are as follows:

- Handle aperture
- Engine rpm
- Handle aperture rate

The Marelli control unit performs the following functions:

1. Implements the necessary strategies for calculating torque demand
2. Operates the sensors and actuators necessary for system function
3. Safety checks for the Ride by Wire system

Removing the injector

To optimise engine performance, there are four lower injectors on the throttle bodies and four upper injectors on the filter box. Except during transition stages, only the lower or the upper injectors are working at any given time.

- The lower injectors optimise tractability and reduce emissions and fuel consumption
- The upper injectors are designed for maximum power output and, as a result, have a high fuel flow rate

The electrical connectors are colour coded as follows to prevent accidentally swapping the injector connectors:

- Cylinder 1: Black
- Cylinder 2: Brown
- Cylinder 3: Green
- Cylinder 4: Grey



-
- To remove the complete injectors unit, disconnect and remove the engine control unit complete with support
 - Undo the four screws fixing the injectors unit to the filter box

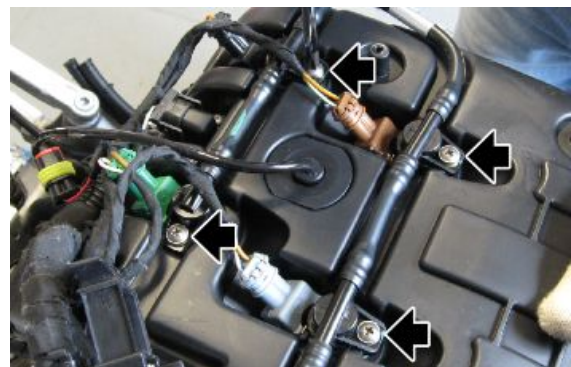

- Remove the complete injectors unit from the filter box, disconnect the four connectors of the injectors and remove the complete injectors unit.

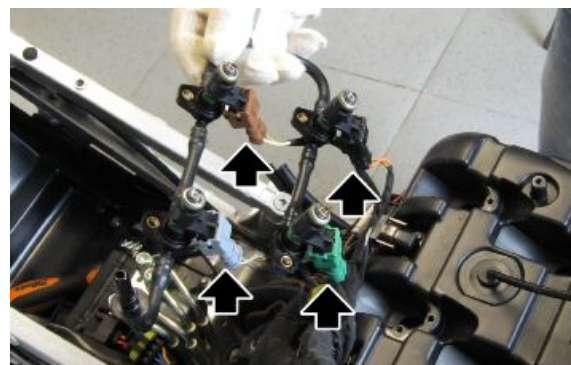

Removing the throttle body

- Completely remove the air filter box.
- Disconnect the injector fuel pipe.
- Release the snap fit clamp on the col-lars from the engine.

NOTE

DO NOT RELEASE THE CLAMPS COMPLETELY. LEAVE IN AN INTERMEDIATE POSITION TO FACILITATE REFITTING.

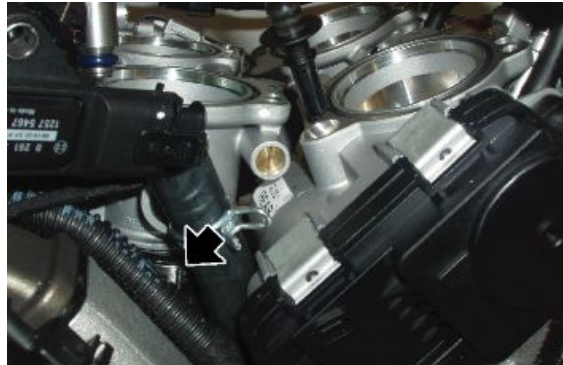

- Disconnect the lower injector connectors.

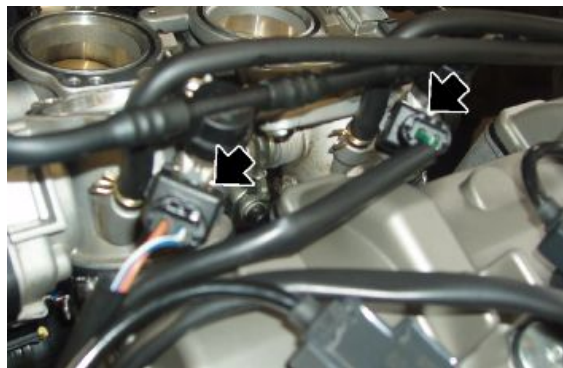

See also

[Air box](#)

- Disconnect the connector.
- Remove the complete throttle body.

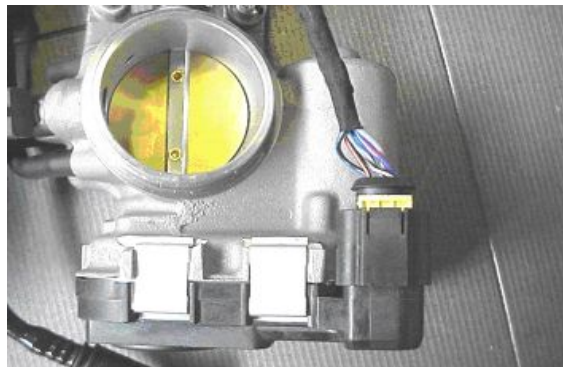

Checking the throttle body

The throttle bodies are maintenance free and are not serviceable. Replace the entire assembly in the event of malfunction.

As all the internal components of the throttle body assembly (potentiometers and electrical motor) are contactless, no electrical diagnosis is possible. Functional tests are performed on the throttle body assembly by the control unit during vehicle operation, with the results visible on the diagnostic instrument.

The only action possible before replacing the component is checking the connectors and cable harnesses.



Installing the throttle body

- When installing the throttle body, refer to the electrical system section for the correct cable routing.
- Ensure that the injector connectors are correctly fastened.
- Connect the control unit connector, ensuring that the security lock is in the locked position.

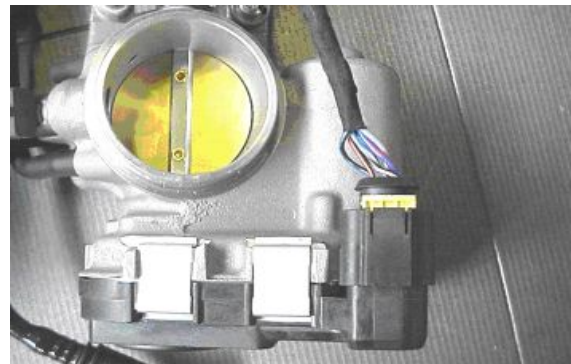

Stepper motor

The control unit regulates the idle speed by controlling the throttle body motors directly. As a result, idle speed adjustment and maintenance of the components involved in idle speed regulation (stepper motors, thermoactuators, etc.) are not necessary.

INDEX OF TOPICS

SSUSPENSIONS

SUSP

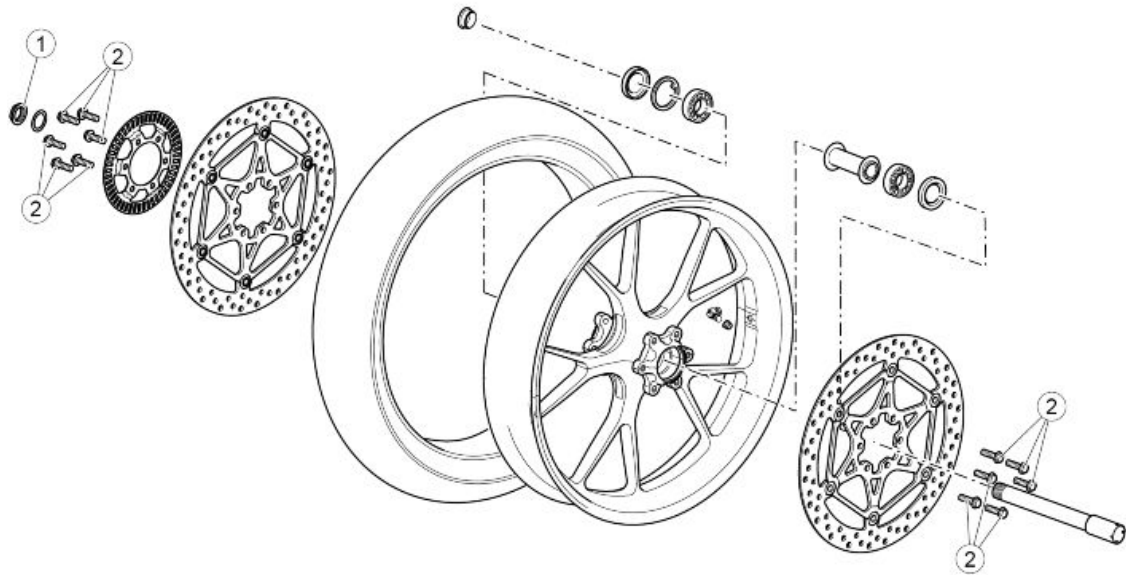
Front
**FRONT WHEEL**

Pos.	Description	Type	Quantity	Torque	Notes
1	Front wheel pin nut	M25x1.5	1	80 Nm (59.00 lb ft)	-
2	Front brake disk fastening screws	M8	6 + 6	30 Nm (22.13 lb ft)	Loct. 243

Removing the front wheel

- Support the front part of the motorcycle.
- Remove the front mudguard.
- Unscrew the front calliper fixing screws and slide them off the disk, taking care to retrieve the spacers.



- Remove the wheel hub fastening nut.
- Retrieve the sealing washer.



- Loosen the screws on the shaft clamps.

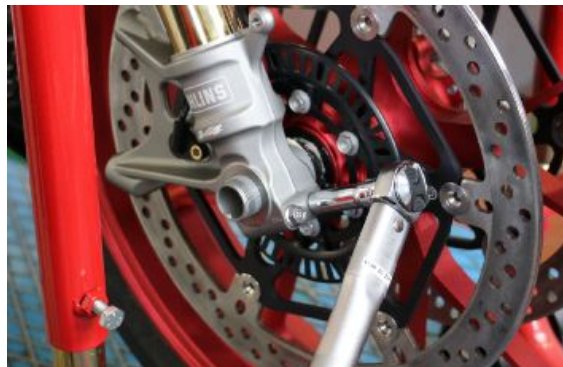

- Strike the wheel pin gently using a rubber mallet in order to extract it more easily.
- If necessary, insert a screwdriver into the holes on the pin.



- Support the wheel while extracting the pin, and then remove it.

Checking the front wheel

FRONT WHEEL BEARINGS

Check the bearings installed on the wheel.



CHECK THE CONDITION OF ALL COMPONENTS AND OF THE COMPONENTS INDICATED AS FOLLOWS IN PARTICULAR.

CHECKING ROTATION

- Manually rotate the inner race of each bearing. The race must turn smoothly without impediment or noise.

If one or both bearings are not conformant:

- Replace both wheel bearings.

CHECKING RADIAL AND AXIAL PLAY

- Check the radial and axial play.

Axial play: minimal axial play is permitted.

Radial: none.

If one or both bearings are not conformant:

- Replace both wheel bearings.



ALWAYS REPLACE BOTH BEARINGS.

ALWAYS REPLACE THE BEARINGS WITH COMPONENTS OF THE SAME TYPE.

SEALS

- Check the condition of the seals; replace if damaged or excessively worn.



ALWAYS REPLACE BOTH SEALS TOGETHER.

ALWAYS REPLACE THE SEALS WITH COMPONENTS OF THE SAME TYPE.

WHEEL AXLE

- Use a dial gauge to check the wheel axle eccentricity. Replace the wheel axle if the eccentricity exceeds the limit value.

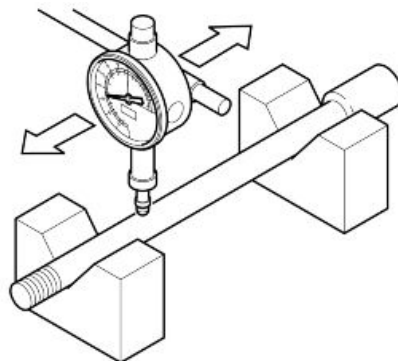

Characteristic

Maximum eccentricity:

0.25 mm (0.0098 in)

- Using a dial gauge, check that the radial (A) and the axial (B) eccentricities of the rim do not exceed the limit value. An excessive eccentricity is usually caused by worn or damaged bearings. Replace the rim if, after replacing the bearings, the value is not within the specified limit.

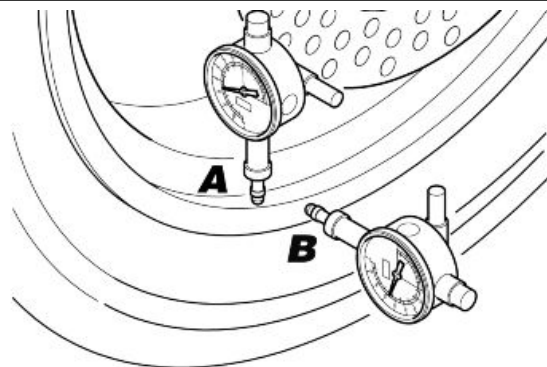

Characteristic

Maximum radial and axial eccentricity:

0.8 mm (0.031 in)

Handlebar

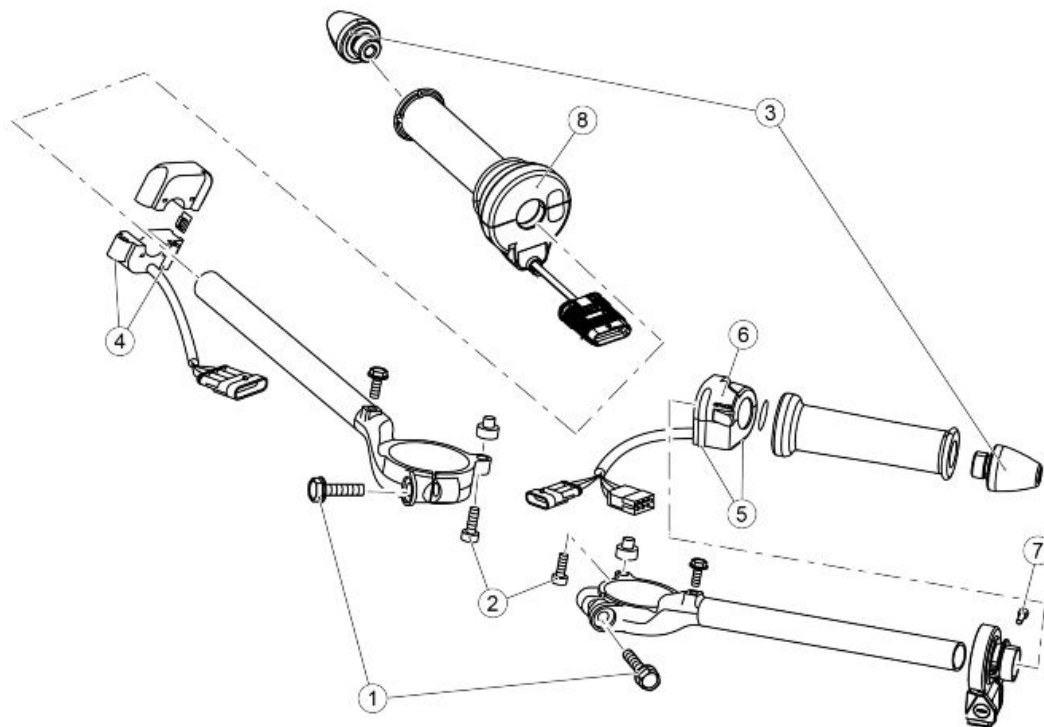

HANDLEBAR AND CONTROLS

Pos.	Description	Type	Quantity	Torque	Notes
1	Screws for fastening the handlebar collar to the forks sleeves	M8	1 + 1	25 Nm (18.44 lb ft)	-
2	Handlebar safety screw	M6	1+1	10 Nm (7.38 lb ft)	-
3	Anti-vibration counterweight fastener	M18x1.5	1+1	20 Nm (14.75 lb ft)	-
4	RH light switch	M5	2	1.5 Nm (1.11 lb ft)	-
5	LH light switch (outer shell)	M4	2	1.5 Nm (1.11 lb ft)	-
6	LH light switch (int. clamp)	M3	2	0.5 Nm (0.37 lb ft)	-
7	Traction control command fastening screw	M4	1	2.5 Nm (1.84 lb ft)	-
8	Screw for fastening the Ride-By-Wire control to the semi-handlebar	M4	1	2,2 Nm (1.62 lb ft)	-

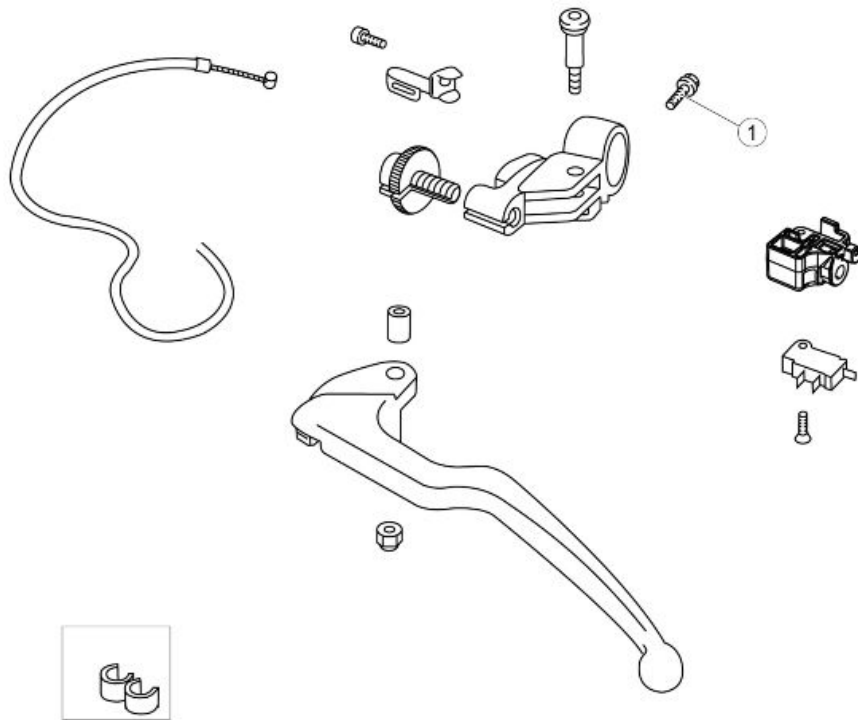

CLUTCH LEVER

Pos.	Description	Type	Quantity	Torque	Notes
1	Clutch lever collar fastening screws	M6	1	10 Nm (7.38 lb ft)	-

Front fork

(OHLINS FORKS)

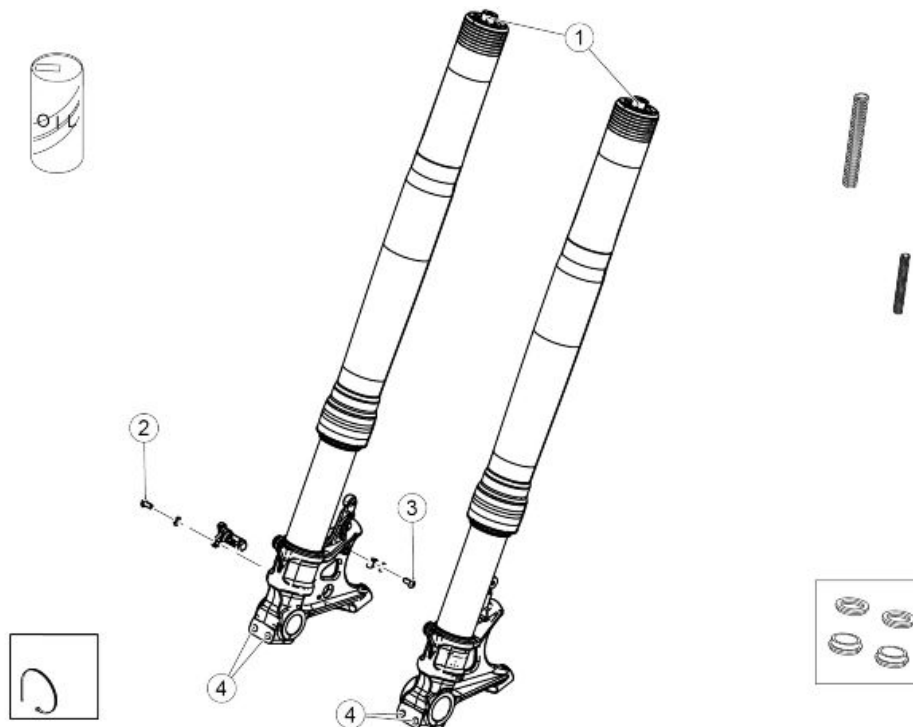

FRONT FORKS - OHLINS

Pos.	Description	Type	Quantity	Torque	Notes
1	Calliper bracket fixing screws (Oh-lins)	M6	2 + 2	12 Nm (8.85 lb ft)	-
2	Speed sensor fastening screw	M5	1	6 Nm (4.43 lb ft)	-
3	Cable gland fastening screw	M5	1	8 Nm (5.90 lb ft)	-

(SACHS FORKS)

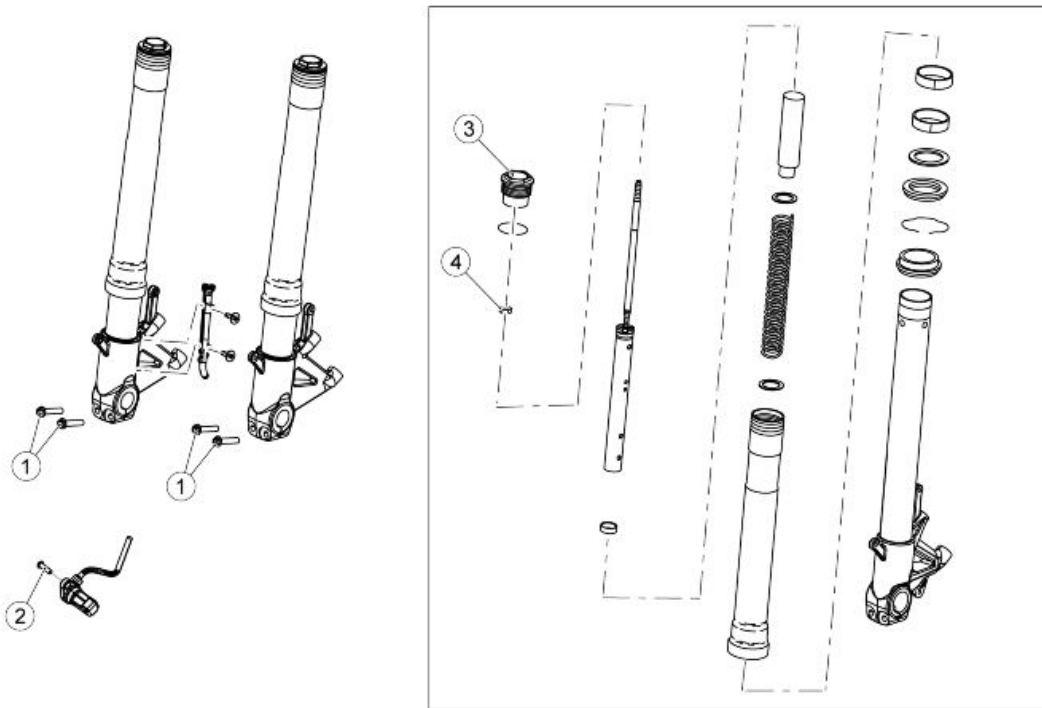

FRONT FORKS - SACHS

Pos.	Description	Type	Quantity	Torque	Notes
1	Calliper bracket fixing screws (Sachs)	M6	4	12 Nm (8.85 lb ft)	-
2	Speed sensor fastening screw	M5	1	6 Nm (4.43 lb ft)	-
3	Upper cap	-	2	20 Nm (14.75 lb ft)	-
4	Upper cap locking nut	-	2	20 Nm (14.75 lb ft)	-

Adjustment

The front suspension consists of a hydraulic fork connected to the headstock by means of two plates.

For the settings of the vehicle set-up:

RSV4 1000 RF

Each stanchion has an upper nut (3) to adjust the spring pre-load.

The left stem is also equipped with an upper set screw (2) for adjusting compression damping.

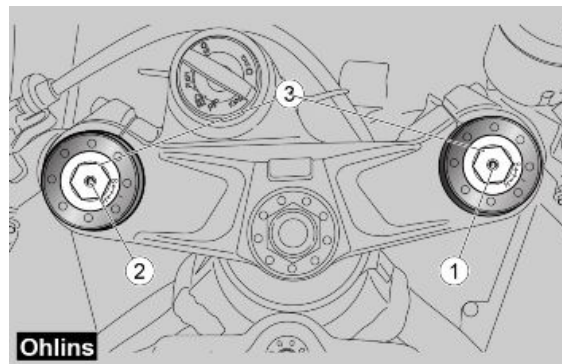

The right stem is also equipped with an upper adjuster screw (1) for adjusting hydraulic rebound damping.

RSV 1000 RR

Each fork has a top adjustment screw (1) to set the rebound damping; an upper nut (3) to adjust the spring pre-loading and a lower adjustment screw (2) to modify the compression damping.



IN ORDER TO AVOID DAMAGES DO NOT FORCE THE SET SCREWS TO TURN BEYOND THE END OF THE STROKE ON BOTH SIDES. SET THE SAME SPRING PRE-LOAD AND HYDRAULIC DAMPING SETTING FOR BOTH STANCHIONS: RIDING THE VEHICLE WITH DIFFERENT SETTINGS FOR THE TWO STANCHIONS REDUCES STABILITY. WHEN SPRING PRE-LOAD IS INCREASED, REBOUND DAMPING MUST ALSO BE INCREASED TO PREVENT EXCESSIVE SUSPENSION KICKBACK WHEN RIDING.

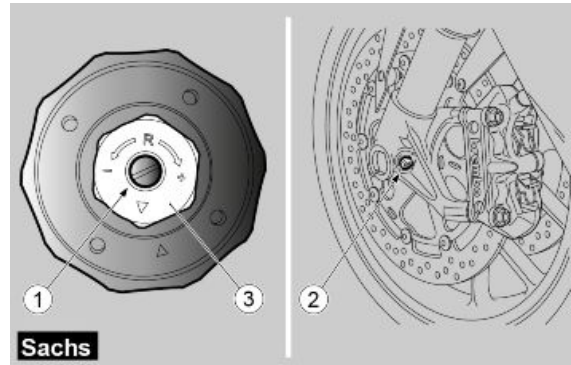

RSV4 1000 RF (Öhlins fork)



TO COUNT THE NUMBER OF CLICKS AND/OR REVOLUTIONS OF ADJUSTMENT SETTINGS ALWAYS START FROM THE MOST RIGID SETTING (WHOLE CLOCKWISE ROTATION OF THE SETTING).

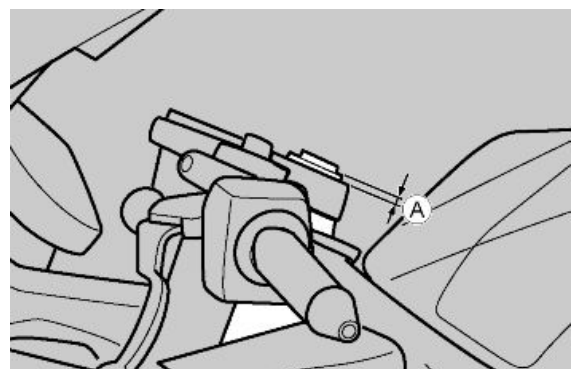
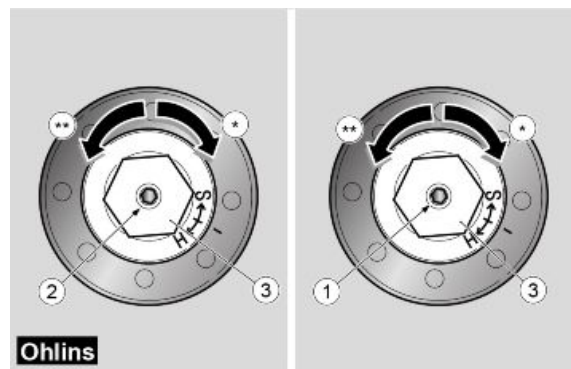

FRONT FORK - RSV4 1000 RF - STANDARD ADJUSTMENT (ÖHLINS) (FOR ROAD USE ONLY)

Specification	Desc./Quantity
Rebound damping adjustment, screw (1)	Unscrew (**) 12 clicks from fully closed (*)
Compression damping adjustment, screw (2)	Unscrew (**) 12 clicks from fully closed (*)
Spring pre-loading, nut (3)	screw (*) 10 turns from fully open (**)
Stems (A) protrusion from top plate (excluding cover)	3 notches/ 12 mm (3 notches/0.47 in)

FRONT FORK - RSV4 1000 RF - RACING ADJUSTMENT RANGE (OHLINS) (TRACK USE ONLY)

Specification	Desc./Quantity
Rebound damping adjustment, screw (1)	Unscrew (**) 10 clicks from fully closed (*)
Compression damping adjustment, screw (2)	Unscrew (**) 7 clicks from fully closed (*)
Spring pre-loading, nut (3)	screw (*) 10 turns from fully open (**)
Stems (A) protrusion from top plate (excluding cover)	3 notches/ 12 mm (3 notches/0.47 in)

RSV4 1000 RR (Sachs forks)



TO COUNT THE NUMBER OF CLICKS AND/OR REVOLUTIONS OF ADJUSTMENT SETTINGS ALWAYS START FROM THE MOST RIGID SETTING (WHOLE CLOCKWISE ROTATION OF THE SETTING).

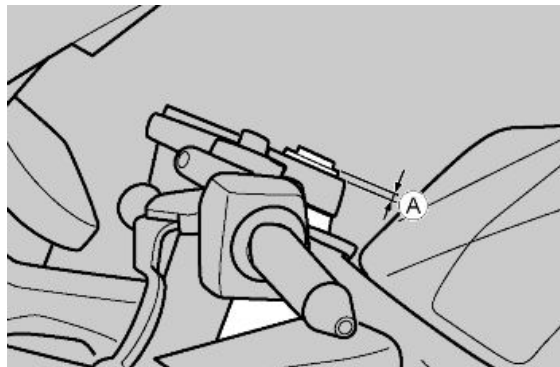
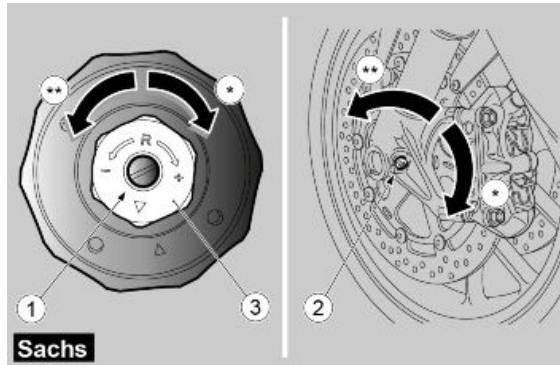

FRONT FORKS - RSV4 1000 RR - STANDARD ADJUSTMENT (SACHS) (FOR ROAD USE ONLY)

Specification	Desc./Quantity
Rebound damping adjustment, screw (1)	Unscrew (**) 10 clicks from fully closed (*)
Compression damping adjustment, screw (2)	Unscrew (**) 6 clicks from fully closed (*)
Spring pre-loading, nut (3)	screw (*) 5 turns from fully open (**)
Stems (A) protrusion from top plate (excluding cover)	2 notches/ 8 mm (2 notches/0.31 in)

FRONT FORK - RSV4 1000 RR - RACING ADJUSTMENT RANGE (SACHS) (TRACK USE ONLY)

Specification	Desc./Quantity
Rebound damping adjustment, screw (1)	Unscrew (**) 8 clicks from fully closed (*)
Compression damping adjustment, screw (2)	Unscrew (**) 4 clicks from fully closed (*)
Spring pre-loading, nut (3)	screw (*) 6 turns from fully open (**)
Stems (A) protrusion from top plate (excluding cover)	2 notches/ 8 mm (2 notches/0.31 in)

(*) = clockwise

(**) = anticlockwise

Removing the fork legs

- Remove the front wheel.
- Support the fork shaft and loosen the screws on the upper plate.



- Disconnect the clutch cable.
- Loosen the screws on the handlebars.



- Loosen the screws on the lower plate.
- Slide out the fork stanchion.



Draining oil

(PROCEDURE FOR OHLINS FORKS)

- Clamp the forks in a vice, taking care not to damage them.
- Set the pre-loading spring to the minimum position.
- Unscrew the upper cap from the sleeve using the special Ohlins tool.



- Loosen the cap using a wrench in order to release the upper nut on the spring retaining ring.
- Unscrew the upper adjustment cap.



- Remove the complete cap.



- Unscrew the nut and remove it, exerting slight pressure on the pre-loading spring.



- Remove the pre-loading spring retaining ring.

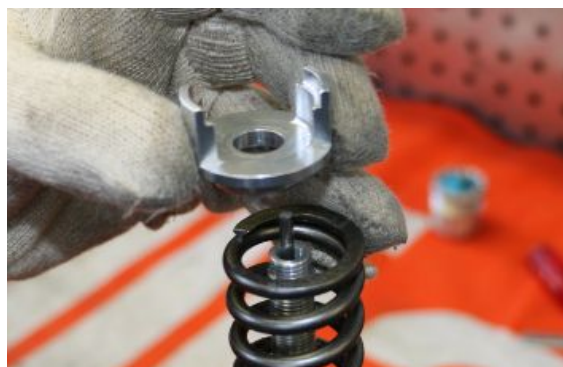

- Remove the pre-loading spring.



- Drain the oil from the forks into a suitable receptacle, taking care not to extract the pre-loading pipe and the hydraulic rebound damping adjustment rod.



(PROCEDURE FOR SACHS FORKS)

NOTE

THE OPERATIONS DESCRIBED BELOW ARE VALID FOR BOTH STANCHIONS.

- Using the appropriate tool fasten the fork in the vice.

Specific tooling

AP8140149 Guard for assembly operations



- Operating on the upper screw, unload the spring.



- Loosen the cover without unscrewing it completely.



- Place the fork vertically locking it in a vice by the specific tool.
- Completely unscrew the plug.

Specific tooling

AP8140149 Guard for assembly operations



- Using the specific tool, fixed to the pre-loading pipe, compress the spring.
- Insert a spanner in the lock nut of the cover.

Specific tooling

020888Y Clamp for pre-load pipe



- Unscrew the cap and remove it.



- Remove the spring preload pipe.



- Remove the lock nut and the washer.



- Remove the spring paying attention to drain the oil correctly.



- Drain the oil into a container of suitable capacity to collect fluids.



DO NOT DISPOSE OF OIL INTO THE ENVIRONMENT. DISPOSE OF ENGINE OIL IN A SEALED CONTAINER AND TAKE IT TO YOUR SUPPLIER OR TO THE NEAREST USED OIL COLLECTION CENTRE.



Disassembling the fork

(PROCEDURE FOR OHLINS FORKS)

- Remove the pre-loading tube.



- Remove the wheel holder shaft (1) and the sleeve (2).



- Clamp the sleeve in a vice and, by levering it alternately at various points, remove the anti-dust seal (3) from the sleeve (2).



- Remove the retaining ring (4).

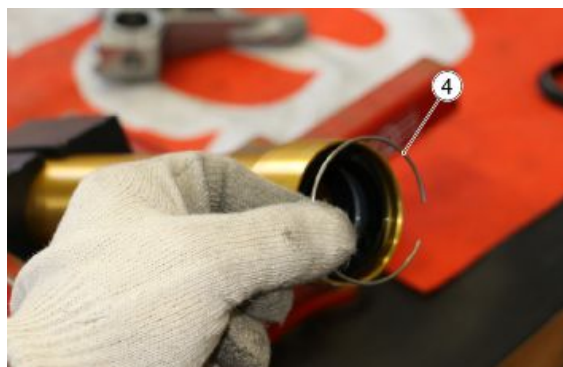

- Remove the shaft seal (5) by levering it alternately at various points.

CAUTION

PROTECT THE EDGE OF THE SLEEVE IN ORDER TO AVOID RUINING IT WHILE REMOVING THE SHAFT SEAL (5).



Replace the following components with new ones:

- shaft seal (5)
- anti-dust seal (3)

CAUTION

PROCEED WITH EXTREME CAUTION IN ORDER TO PREVENT FOREIGN BODIES FROM ENTERING THE SLEEVE OR THE WHEEL HOLDER SHAFT. DO NOT REUSE THE OIL THAT WAS DRAINED EARLIER

(PROCEDURE FOR SACHS FORKS)

- Discharge the fork, remove the internal dipstick of the pumping member pin (1) and the washer (2).
- Operate repeatedly on the pumping member pin (3) so as to drain completely the oil from inside.



- Slide off the dust scraper from the sleeve using a screwdriver as a lever.
- During this operation, pay attention not to damage the sleeve rim.

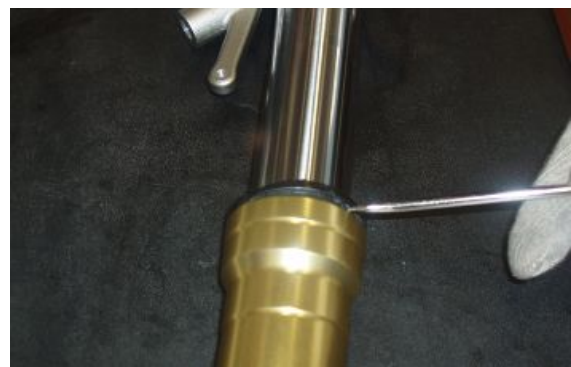

- Remove the retainer ring.



- Take out the sleeve from the stem using the stem as a hammer puller.
- Remove the fixed bushing (1), the movable bushing (2), the ring (3) and the oil seal (4) from the stem.

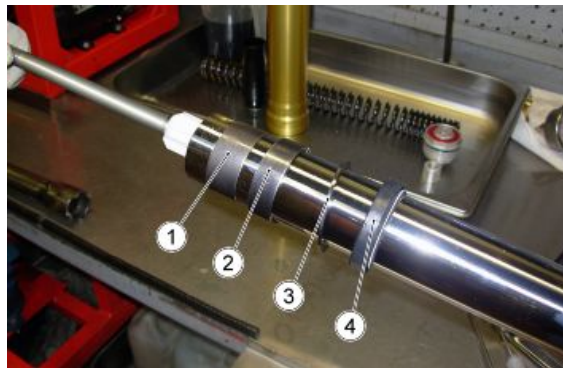

- Remove the lock seeger ring of the spring guide.
- Remove the spring guide.

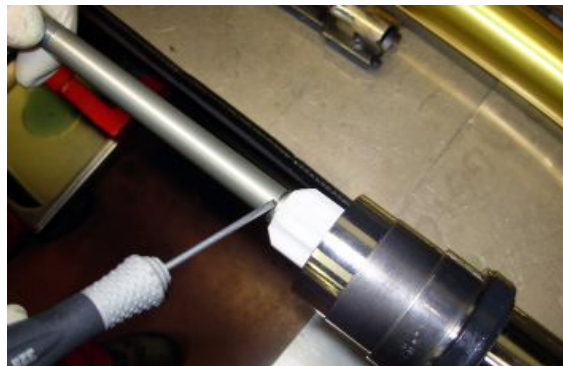

- Using a hook spanner lock the pumping member pin.
- Remove the stem bottom screw.

Specific tooling

020889Y Wrench for locking pumping unit ring nut



- Remove the pumping member pin.



Checking the components

(PROCEDURE FOR OHLINS FORKS)

Stem

Check that the sliding surface is not scratched or scored.

Any scoring can be removed by sanding with damp sandpaper (grain 1).

If the scratches are deep, replace the stem.

Using a dial gauge, check that any bending of the stem is below the limit value.

If it is over the limit, replace the stem.

CAUTION

A BENT STEM SHOULD NEVER BE STRAIGHTENED SINCE ITS STRUCTURE WOULD BE WEAKENED MAKING THE VEHICLE DANGEROUS TO USE.

Characteristic

Bending limit:

0.2 mm (0.00787 in)

Sleeve

Check for damage and/or cracks; if it is damaged, replace it.

Springs

Check the condition of the springs, making sure that the length is within the acceptable limits.

If not, replace the springs.

MINIMUM LENGTH OF FREE SPRING: 260 mm (10.24 in)

(PROCEDURE FOR SACHS FORKS)

Stem

Check that the sliding surface is not scratched or scored.

Any scoring can be removed by sanding with damp sandpaper (grain 1).

If the scratches are deep, replace the stem.

Using a dial gauge, check that any bending of the stem is below the limit value.

If it is over the limit, replace the stem.

CAUTION

A BENT STEM SHOULD NEVER BE STRAIGHTENED SINCE ITS STRUCTURE WOULD BE WEAKENED MAKING THE VEHICLE DANGEROUS TO USE.

Characteristic

Bending limit:

0.2 mm (0.00787 in)

Sleeve

Check that there are no damages and/or cracks; otherwise, replace it.

Spring

Check that the spring is in good conditions. Check that the spring length is within the limit value.

Replace the spring if its length does not fall within the limit values.

SPRING MINIMUM LENGTH WHEN UNLOADED: 265 mm (10.4 in)

Check that the following components are in good conditions:

- upper bushing;



- lower bushing;



- plunger.

If there is evidence of excessive wear or damage, replace the component concerned.

CAUTION

REMOVE ANY IMPURITIES FROM THE BUSHINGS, BEING CAREFUL NOT TO SCRATCH THEIR SURFACES.

Reassembling the fork

(PROCEDURE FOR OHLINS FORKS)

- Install the following components on the wheel holder stanchion (1) in the order given: dust gaiter (3), retainer ring (4) and oil seal (5).

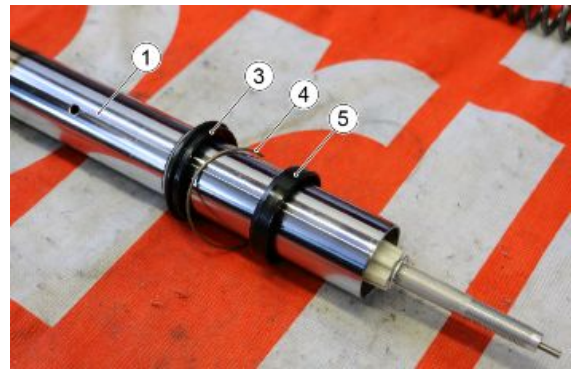

- Fix the sleeve in a vice, taking care not to damage the sleeve.
- Insert the stanchion (1) into the sleeve (2).



- Position the two halves of the special tool on the shaft (1) behind shaft seal (5), together with the respective buffer.
- Grip the special tool and push the shaft seal (5) into its housing on the sleeve (2).
- Remove the tool.



- Insert the retaining ring (4) into its housing on the sleeve (2).

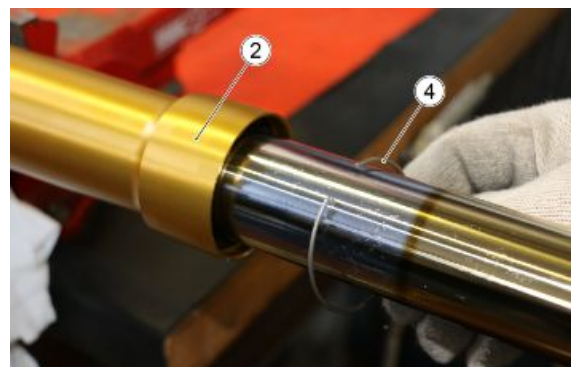

- Position the two halves of the special tool on the shaft behind anti-dust seal (3), together with the respective buffer.
- Grip the special tool and push the anti-dust seal (3) into its housing on the sleeve (2).
- Grasp the shaft and move it slowly, in alternating directions a few times.

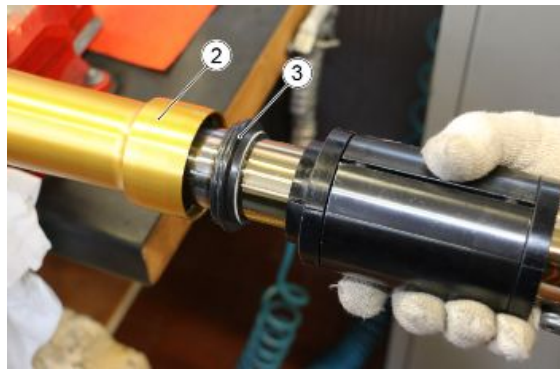

CAUTION

THE SHAFT MUST SLIDE FREELY WITHIN THE SLEEVE, WITHOUT OBSTRUCTIONS.

(PROCEDURE FOR SACHS FORKS)

NOTE

THE OPERATIONS DESCRIBED BELOW ARE VALID FOR BOTH STANCHIONS.

- Lock the stem in a vice without damaging the surface.
- Protect the bearing tube end with adhesive tape.
- Lubricate the sliding edges with fork oil or sealing grease.
- Fit the dust gaiter, the retainer ring and the dust scraper on the stem.
- Fit the ring, the movable bushing and, after removing the tape, fit the fixed bushing.



- Fit the sleeve on the stem and set the oil seal into position with the aid of the specific tool.

Specific tooling

AP8140189 Tool for fitting oil seal for 43 mm (1.69 in) diameter hole

AP8140146 Weight

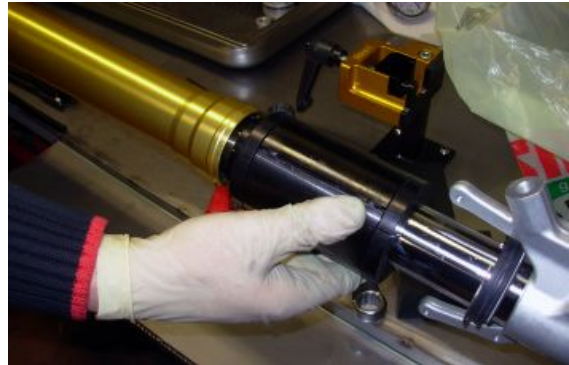

- Insert the retainer ring in its position.



- Fit the dust gaiter with the specific tool.

Specific tooling

AP8140189 Tool for fitting oil seal for 43 mm (1.69 in) diameter hole

AP8140146 Weight



- Insert the pumping member pin in the stem.



- Using a hook spanner lock the pumping member pin and tighten the fixing screw on the fork end to the prescribed torque.

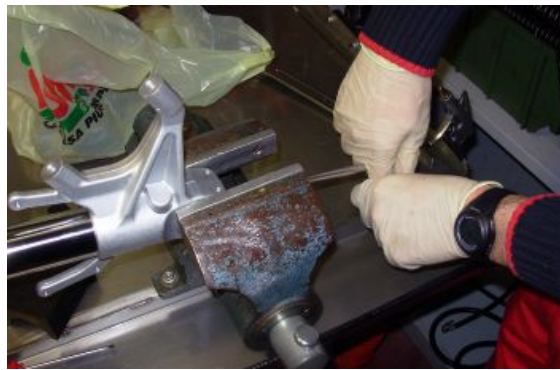

Specific tooling

020889Y Wrench for locking pumping unit ring nut

Filling oil

(PROCEDURE FOR OHLINS FORKS)

- Clamp the forks in a vice using the special tool.
- Fill the forks with oil until the air bubbles trapped inside are forced out.

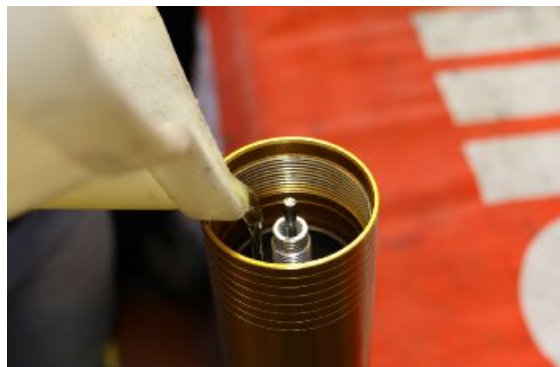

Oil level: 191 mm (7.52 in) (from the edge of the sleeve, without spring or pre-loading tube).



THE SLEEVE MUST BE PERFECTLY UPRIGHT IN ORDER TO MEASURE THE CORRECT OIL LEVEL. THE OIL LEVEL MUST BE THE SAME IN BOTH STANCHIONS.

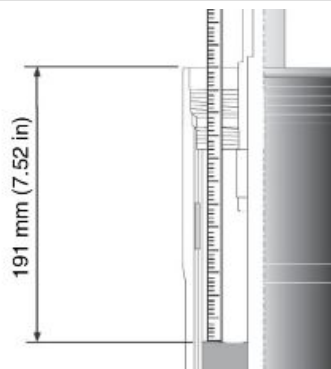

Characteristic

Oil for forks

421 cc (0,093 Uk gal) (for each shaft)

- Insert the pre-loading spring while maintaining the pin in the raised position.

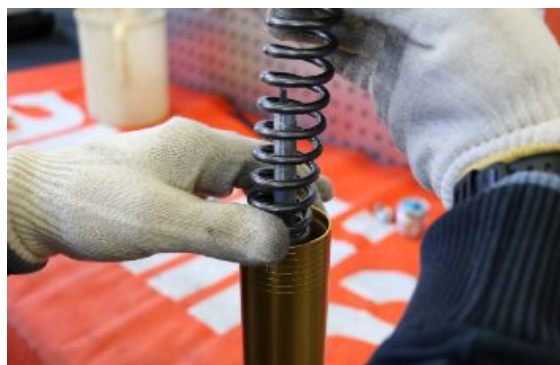

- Insert the pre-loading spring retaining ring (1).
- Insert the nut (2).
- While maintaining the spring compressed, tighten the nut as far as it will go.



- Screw the complete cap into place on the plunger pin.



- Tighten the cap using a wrench to lock the lower spring retaining ring nut.
- Screw the upper regulator cap into place, until comes into contact with the lower nut on the cap, and then tighten by applying the pre-defined torque.



- Using the special Öhlins tool, tighten the upper cap, applying the pre-defined torque.



(PROCEDURE FOR SACHS FORKS)

- Clamp the forks in a vice using the special tool.

- Fill the forks with oil, according to the indicated quantities.

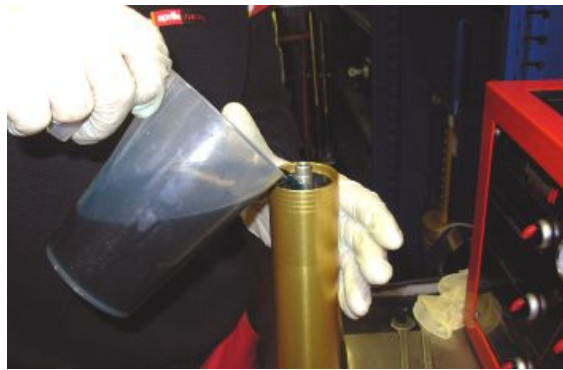

- Wait a few minutes until the oil fills all the ducts.
- Pour the remaining oil.
- Pump out oil a few times.
- Measure the air gap between the oil level and the rim.



THE SLEEVE MUST BE PERFECTLY UPRIGHT IN ORDER TO MEASURE THE CORRECT OIL LEVEL. THE OIL LEVEL MUST BE THE SAME IN BOTH STANCHIONS.

Oil level: 110 +/- 2 mm (4.33 +/- 0.08 in) (from edge of sleeve, without spring and with pre-loading tube).



THE SLEEVE MUST BE PERFECTLY UPRIGHT IN ORDER TO MEASURE THE CORRECT OIL LEVEL. THE OIL LEVEL MUST BE THE SAME IN BOTH STANCHIONS.

Characteristic

Oil for forks

427 +/- 5 cc (26.06 +/- 0.30 cu in) (for each shaft)

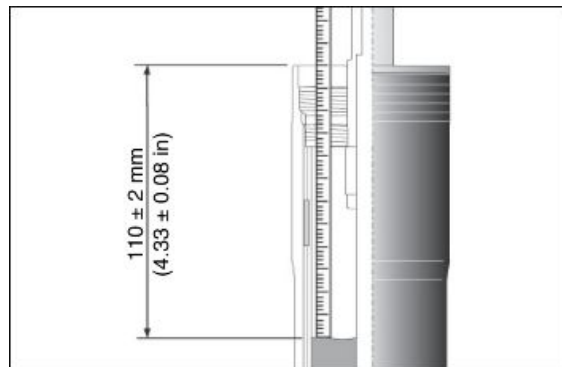

- Insert the spring.

CAUTION

PROCEED WITH CAUTION WHEN INSERTING THE SPRING AND ENSURE THAT THE PART WHERE THE SPIRAL IS MORE COMPRESSED IS FACING DOWNWARDS.



- Insert the spring guide and lock it in place using the respective snap ring.

- Position the forks vertically.
- Insert the base washer.

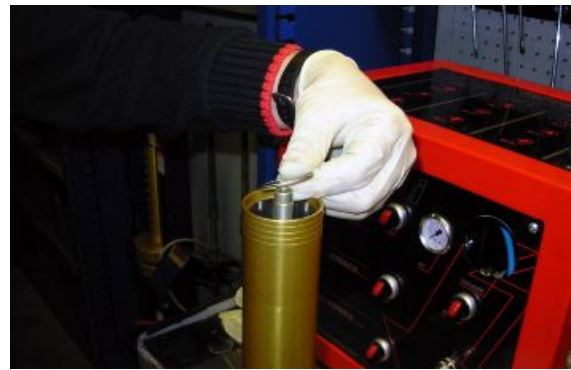

- Insert the nut on the plunger and hand tighten it
- Position the pre-loading tube.
- Screw the special tool onto the plunger shaft and maintain it in the raised position as long as possible, in order to insert a wrench on the nut, while compressing the spring.

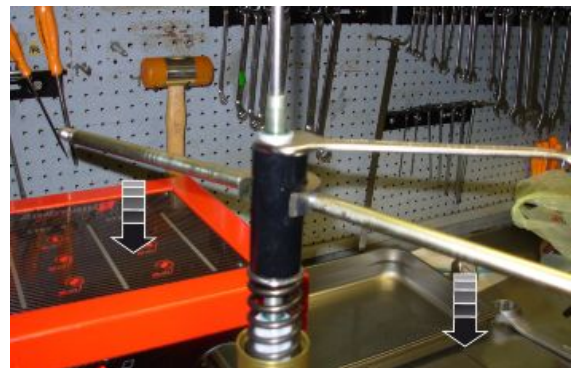

Specific tooling

020890Y Support rod of pumping unit station

AP8140147 Spacer retaining device

- Tighten the nut as much as possible.
- Insert the cover and tighten until it stops.



- Remove the specific tools.
- Screw the cover in the sleeve to the prescribed torque.



Steering damper

Adjusting



ONLY FOR VERSION RSV4 1000 RF:

the steering damper can be adjusted by turning the knob (1).

- Turning the knob (1) clockwise will cause the steering to take on a more rigid behaviour.
- Turning it anticlockwise will cause the steering to take on a softer behaviour.



SPORT SETTINGS MAY BE USED ONLY FOR OFFICIAL COMPETITIONS TO BE CARRIED OUT ON TRACKS, AWAY FROM NORMAL ROAD TRAFFIC AND WITH THE AUTHORISATION OF THE RELEVANT AUTHORITIES.



CARRY OUT THE ADJUSTMENT ONLY WHEN THE VEHICLE IS AT STANDSTILL. AFTER CHANGING THE ADJUSTMENTS, ALWAYS ENSURE THAT THE STEERING IS FREE IN BOTH ROTATION DIRECTIONS.

STEERING DAMPER - STANDARD ADJUSTMENT (FOR ROAD USE)

Specification	Desc./Quantity
Damping adjustment	screw (*) 8 clicks from fully open (**)

STEERING DAMPER - RACING ADJUSTMENT RANGE (ONLY TRACK USE)

Specification	Desc./Quantity
Damping adjustment	screw (*) 17 clicks from fully open (**)

ONLY FOR VERSION RSV4 1000 RR:

The **RSV4 1000 RR** version is fitted with a non-adjustable steering damper. No adjustments can be carried out.

(*) = clockwise

(**) = anticlockwise

Removing

The steering damper steering more precise and stable, improving motorcycle handling in all conditions The damper is fastened at the front of the motorcycle between the bottom yoke and the frame



Removal:

- Unscrew the chassis fixing screw.
- Unscrew the fixing screw at the bottom yoke.
- Remove the steering damper.

Steering bearing

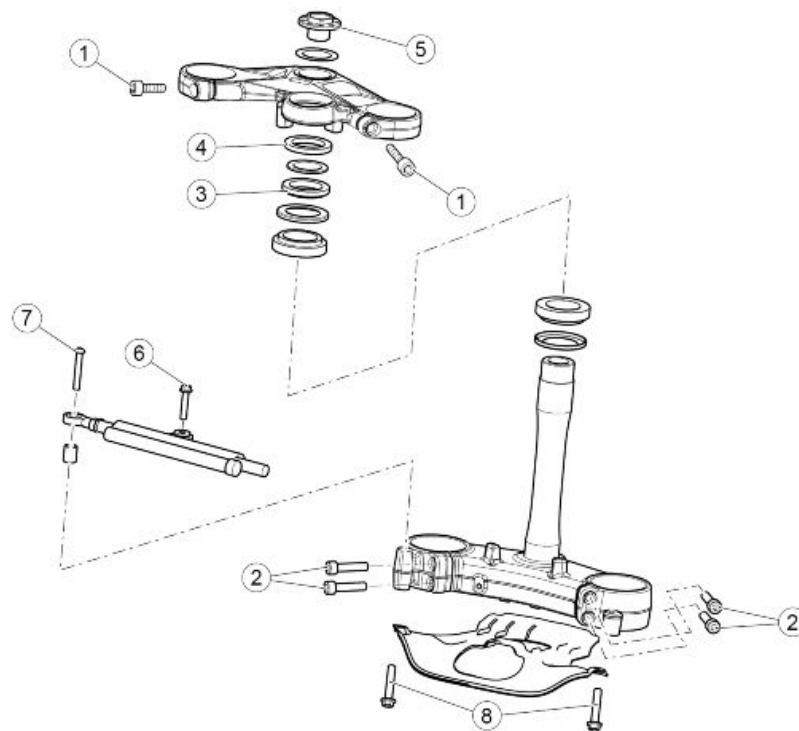

STEERING

pos.	Description	Type	Quantity	Torque	Notes
1	Screws fastening upper yoke to stanchions	M8	2	25 Nm (18.44 lb ft)	-
2	Screws fastening lower yoke to stanchions	M8	4	25 Nm (18.44 lb ft)	-
3	Headstock ring nut - pre-tightening	M35x1	1	70 Nm (51.63 lb ft)	Unscrew after pre-tightening
3	Headstock ring nut - tightening	M35x1	1	60 +/- 9 Nm (44.25 +/- 6.64 lb ft)	-
4	Headstock counter-lock ring	M35x1	1	Manual +35° or -10°	Bend the tabs into the notches in the lock ring

pos.	Description	Type	Quantity	Torque	Notes
5	Upper yoke fixing cap	M29x1	1	100 Nm (73.76 lb ft)	-
6	Screw fastening shock absorber to frame	M6	1	10 Nm (7.38 lb ft)	Loctite 243
7	Screw fastening shock absorber to lower yoke	M6	1	10 Nm (7.38 lb ft)	Loctite 243
8	Lower cover fixing screws	M6	2	8 Nm (5.90 lb ft)	-

Adjusting play

- Place the vehicle so that the front wheel is off the ground.
- Carry out a handlebar rotation test, using a dynamometer at the hand grip external end.
- The handlebar resistance to rotation must be of 450 (+250 / -100 g) (0.88 +0.55 / -0.22 lb) in both directions.
- Adjust if clearance is detected.

NOTE

THE STEERING COLUMN RESISTANCE TO ROTATION MUST BE PERFORMED IN THE TWO OPPOSITE ROTATION DIRECTIONS.

THE STEERING DAMPER MUST BE DISCONNECTED DURING MEASUREMENT.

- Unscrew and remove the top bolt on the headstock and retrieve the washer.



- Loosen the screws fixing the fork stand-chions to the upper yoke.



- Working from both sides, unscrew and remove the semi-handlebar screws.



- Remove the upper yoke



- Rivet the safety washer on the headstock.



- Undo the counter-lock ring, remove the safety washer then unscrew the lower lock ring in order to adjust the steering free play correctly.





- Tighten the lower lock ring to a torque of 70 Nm (51.63 lb ft).
- Steer repeatedly completely left and completely right to allow the bearings to settle.
- Loosen the ring nut.
- Retighten the lock ring to the prescribed torque of 60 Nm +/- 9 Nm (44.25 lb ft +/- 6.64 lb ft).
- Steer completely left and completely right and check that the steering rotates smoothly and without excessive resistance.
- If any problems are noted, repeat the procedures described above.

**NOTE**

DISCONNECT THE STEERING DAMPER WHEN ADJUSTING THE STEERING FREE PLAY.

Specific tooling**AP8140190 Tool for steering tightening**

- Fit the safety washer and bend the two opposing tabs into the notches on the lock ring.



- Fit the counter-lock ring, hand tightening only.
 - To allow the tabs to be bent into the notches of the counter-lock ring in order to lock the ring, the counter-lock ring may be tightened further by up to 35° or loosened by up to 10°.
 - When tightening the counter-lock ring, hold the lock ring still with an appropriate hook spanner.
 - Lock the counter-lock ring by bending the tabs of the retainer washer into the notches in the counter-lock ring itself.
 - Reconnect the steering damper.
-
- Fit the upper fork plate.



Disassembling

- Remove the steering assembly completely.
- Unscrew and remove the lower dowel fastening the collar.
- Remove the lower collar.

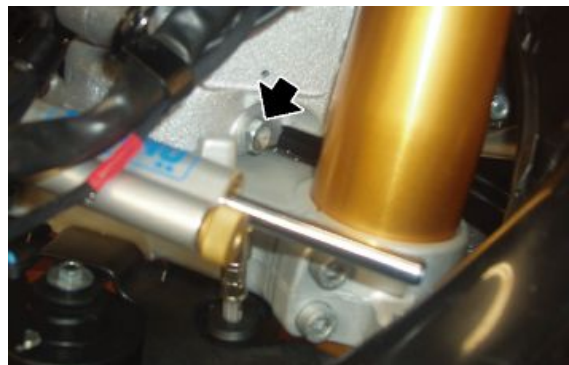

- Unscrew and remove the upper dowel fastening the collar.
- Remove the upper collar.

CAUTION

ALWAYS CHANGE BOTH COLLARS (UPPER AND LOWER).

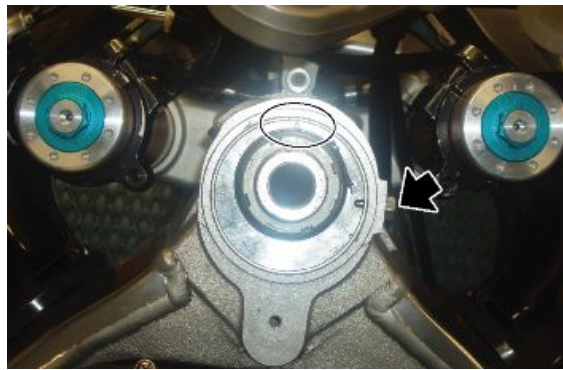

Upper and lower collars are not interchangeable.

To identify them, check the number printed on them:

- lower collar 0.49 mm + 3 mm (0.30 in / + 1.86 in)
- upper collar 0.49 mm + 1.5 mm (0.30 in / + 0.93 in)

Assembling

- Fit the upper collar.
 - Partially tighten the dowel in the relative threaded hole, so that it protrudes by no more than 2 or 3 mm into the conical surface.
 - Fit the bushing in its seat, ensuring that the seal (in the groove in the bushing) remains in place.
 - Press the bushing into place with a rubber mallet.
 - Tighten the dowel to the specified torque.
 - Repeat the procedure for the lower bushing.
-
- Fit the steering assembly and restore the correct steering bearing free play.

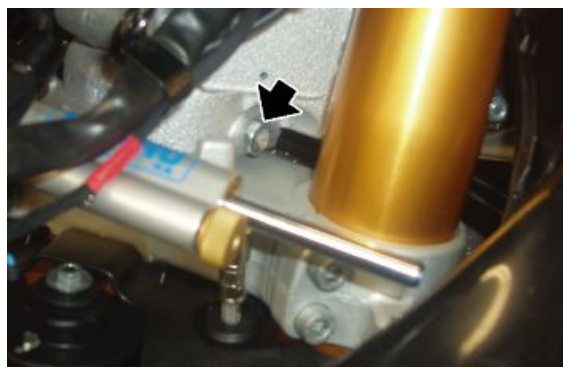

See also

Adjusting play

Rear

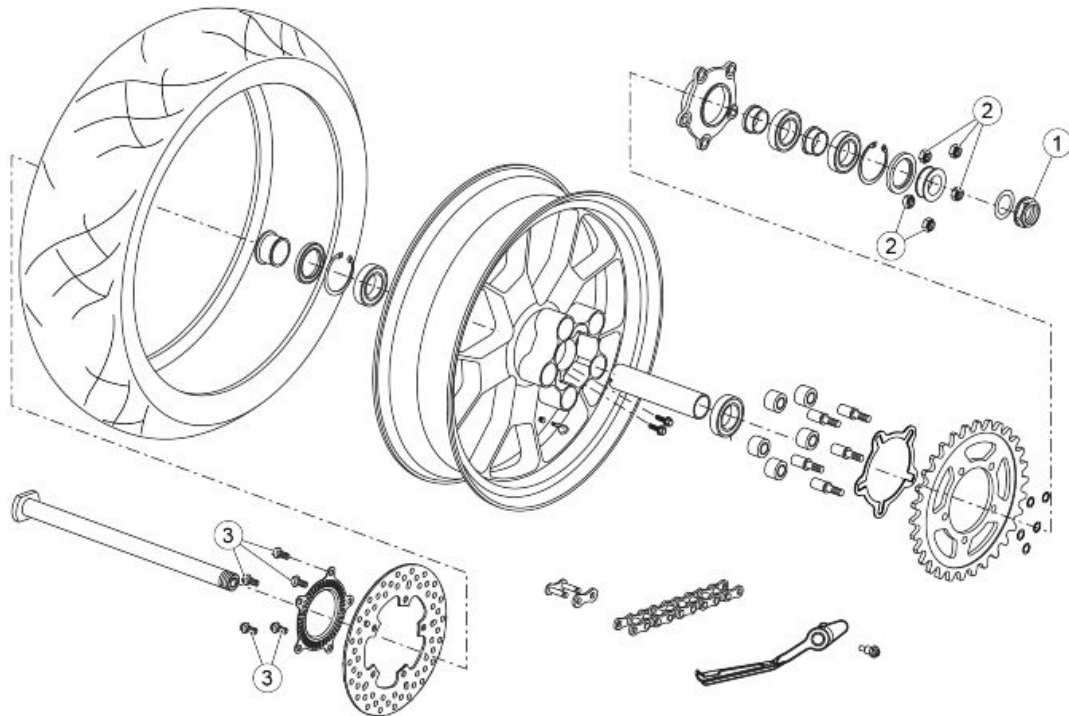
**REAR WHEEL**

Pos.	Description	Type	Quantity	Torque	Notes
1	Rear wheel axle nut	M25x1.5	1	120 Nm (88.51 lb ft)	-
2	Nuts for fastening crown to sprocket	M10	5	50 Nm (36.88 lb ft)	-
3	Rear brake disc fastening screws	M8	5	30 Nm (22.13 lb ft)	Loct. 243

Removing the rear wheel

- Place the vehicle on its rear service stand.
- Loosen and remove the nut on the wheel axle.
- Retrieve the thrust washer and the left hand chain tensioner slider.



- Tap the wheel axle slightly to extract the head from its seat.
- Make the wheel move forward and release the gearing chain from the sprocket.



- Remove the wheel spindle together with the right hand chain tensioner skid.
- Remove the wheel by freeing the disc from the brake calliper.



Parastrappi

REMOVAL

- Remove the final transmission unit

NOTE

THE FLEXIBLE COUPLINGS REMAIN FITTED ON THEIR WHEEL



REMOVAL

- Place the final transmission unit on a vice



TO PROTECT THE CROWN GEAR, INSTALL (WOODEN OR ALUMINIUM) PROTECTIONS ON THE VICE JAWS. LOCK THE CROWN GEAR ONLY IN A VICE. DO NOT LOCK ANY OTHER COMPONENT OF THE FINAL TRANSMISSION UNIT.



- Block the rotation with a hex wrench on the threaded pin (1); Unscrew and remove the DAX nut (2)
- Repeat the operation to remove all nuts and corresponding pins.

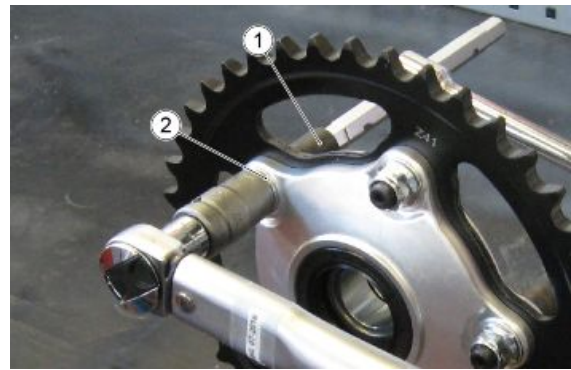

- Remove the sprocket (3) and the flange (4)



FITTING

- Fit the sprocket (3) and the flange (4) on the crown gear



- Place the pins (1) with the corresponding DAX nuts (2) paying attention so the pins are directed towards the inside the machining on the flange

CAUTION



WITH EVERY REMOVAL, REPLACE THE PINS AND NUTS WITH THE NEW COMPONENTS

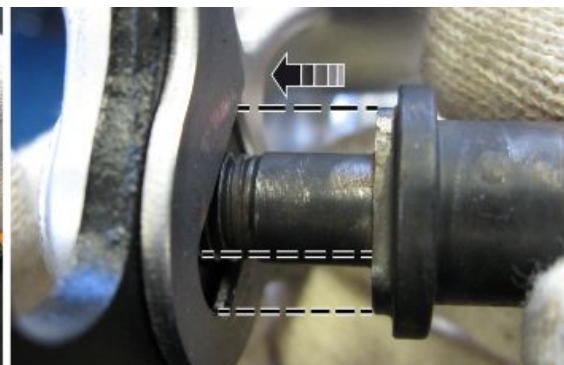

- Block the rotation of the pins with a hex wrench (1) (EVEN IF THE FLANGE ITSELF DOES NOT ALLOW THE ROTATION) and tighten to the prescribed torque, the nuts (2) diametrically opposed in the order: (A) (B) (C) (D) (E).

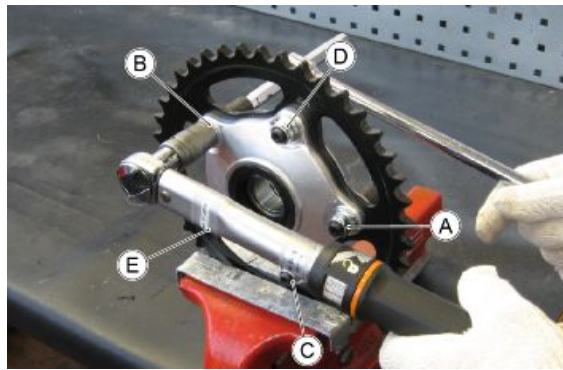
**CAUTION**

IN THIS WAY THE PRESSURE EXERTED BY THE FIXING ELEMENTS WILL BE EVENLY DISTRIBUTED ON THE COUPLING SURFACE.

Checking the rear wheel



CHECK THE CONDITION OF ALL COMPONENTS AND OF THE COMPONENTS INDICATED AS FOLLOWS IN PARTICULAR.

REAR WHEEL BEARINGS

Check the bearings installed on the wheel.

CHECKING ROTATION

- Manually rotate the inner race of each bearing. The race must turn smoothly without impediment or noise.

If one or both bearings do not fall within the control parameters:

- Replace both wheel bearings.



ALWAYS REPLACE BOTH BEARINGS.

ALWAYS REPLACE THE BEARINGS WITH COMPONENTS OF THE SAME TYPE.

- Check the radial and axial play.

Axial play: minimal axial play is permitted.

Radial: none.

If one or both bearings do not fall within the control parameters:

- Replace both wheel bearings.

REAR WHEEL GASKETS

- Check that the gaskets are in good conditions; replace them if they show signs of damage or excessive wear.



ALWAYS REPLACE BOTH SEALS TOGETHER.

ALWAYS REPLACE THE SEALS WITH COMPONENTS OF THE SAME TYPE.

REAR WHEEL AXLE

- Use a dial gauge to check the wheel axle eccentricity (1). Replace the wheel axle if the eccentricity exceeds the limit value (1).

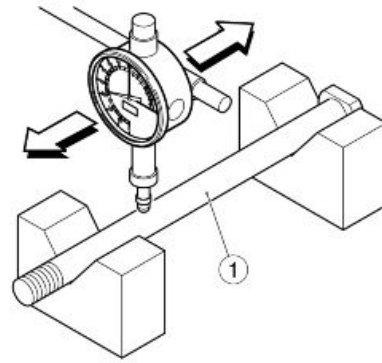
**Characteristic****Maximum eccentricity:**

0.25 mm (0.0098 in)

REAR WHEEL RIM

- Using a dial gauge, check that the radial (A) and the axial eccentricity (B) of the rim (2) do not exceed the limit value.

An excessive eccentricity is usually caused by worn or damaged bearings. Replace the rim (2) if after replacing the bearings, the value is not within the specified limit.

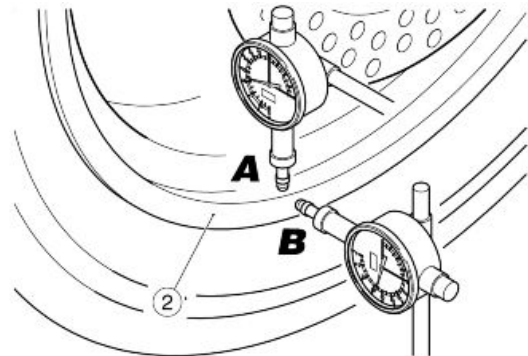
**Characteristic****Maximum radial and axial eccentricity:**

0.8 mm (0.031 in)

FINAL DRIVE UNIT BEARINGS

Carry out the check with the bearings fitted on the final drive unit.

ROTATION CHECK

- Remove the left spacer (3).
- Remove the right spacer (4).
- Manually rotate the inside ring of each bearing. Rotation must be constant, smooth and noiseless.

If one or both bearings do not fall within the control parameters:

- Replace both bearings of the final drive unit.

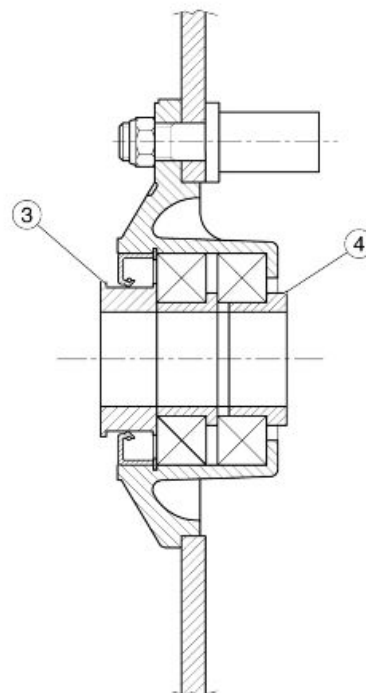
**RADIAL AND AXIAL CLEARANCE CHECK**

- Check the radial and axial clearance. Axial clearance: a minimum axial clearance is allowed.
Radial clearance: none.

If one or both bearings do not fall within the control parameters:

- Replace both bearings of the final drive unit.

FLEXIBLE COUPLING

Check that the flexible couplings (5) are not damaged or excessively worn.

To check:

- Fit the entire final drive unit (6) to the wheel.
- Manually rotate the sprocket (7) to right and left, and check the clearance between the flexible couplings (5) and their holder (8).

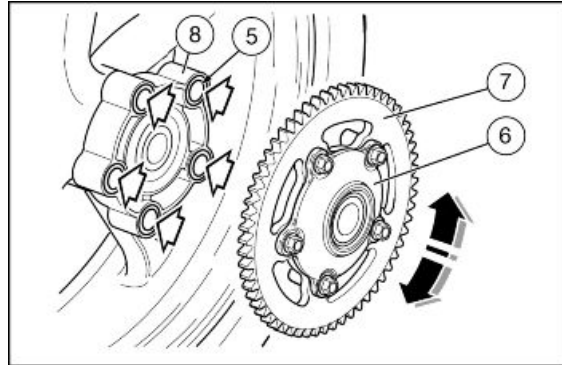

If there is excessive clearance:

- Replace all the flexible couplings (5).



ALWAYS REPLACE ALL THE FLEXIBLE COUPLINGS WITH OTHERS OF THE SAME TYPE.

SPROCKET

- Check the sprocket (7) tooting for proper conditions.

If there is excessive wear:

- Replace the sprocket.



TO PREVENT NEW COMPONENTS FROM WEARING PREMATURELY, THE REAR SPROCKET, FRONT SPROCKET AND DRIVE CHAIN MUST ALWAYS BE REPLACED TOGETHER AS A SET.

REAR WHEEL BEARINGS

- Remove the rear wheel.
- Clean both sides of the hub with a cloth.

On the right hand side of the wheel:

- Remove the right hand spacer (9).
- Remove the seal (10).
- Remove the circlip (11)

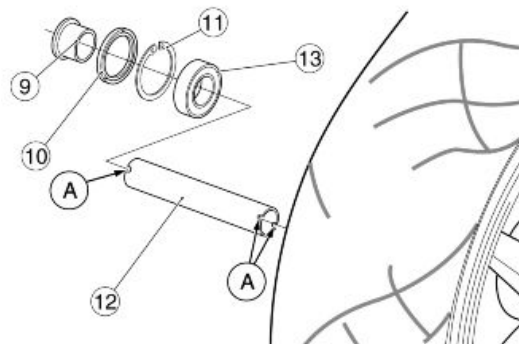

CAUTION

THE CIRCLIP (11) IS ONLY INSTALLED ON THE RIGHT HAND SIDE OF THE WHEEL.

There are notches (A) for engaging with the teeth of the extractor tool at the ends of the spacer (12).

- Use the extractor tool to remove the right hand bearing (13).

Specific tooling

AP8140180 Bearing extractor

- Retrieve the inner spacer (12).

On the left hand side of the wheel:

- Use the extractor tool to remove the left hand bearing (16).

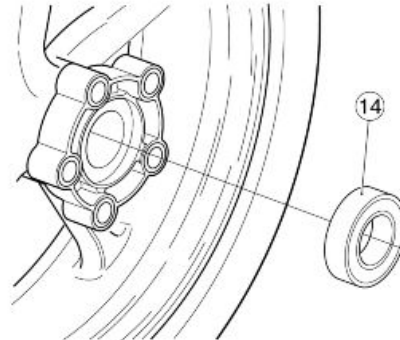

Specific tooling

AP8140180 Bearing extractor

- Clean the interior of the hub thoroughly.

CAUTION

WASH ALL COMPONENTS WITH CLEAN DETERGENT SOLUTION.

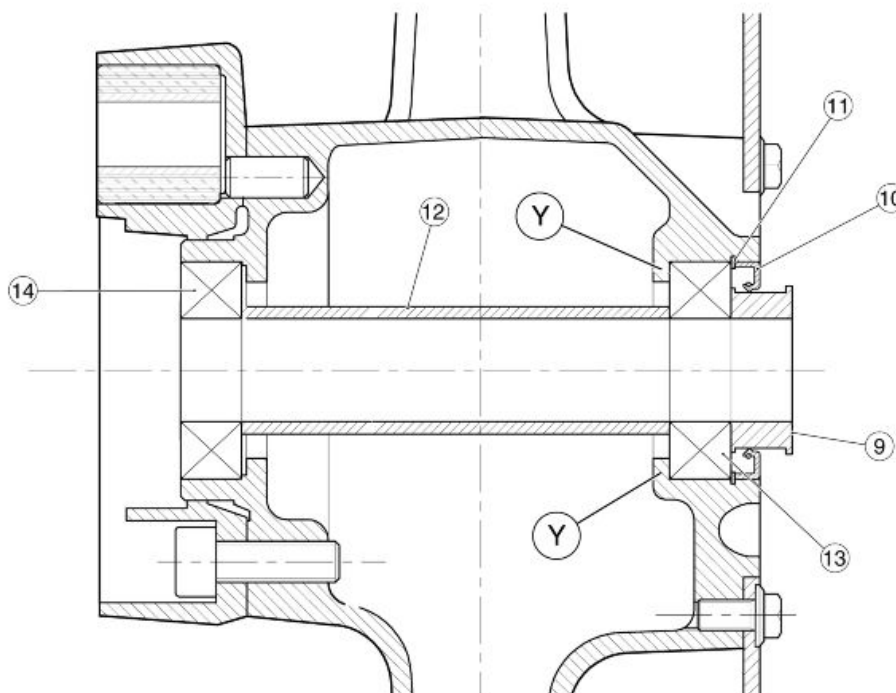

FINAL DRIVE UNIT - BEARING REMOVAL

- Remove the final drive unit.
- Clean the two sides of the hub with a cloth.
- Remove the left spacer (15).
- Remove the sealing gasket (16).
- Remove the circlip (17).

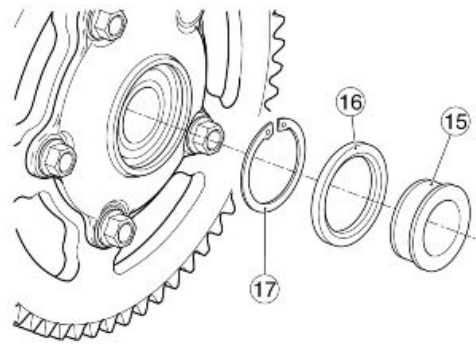

CAUTION

THE CIRCLIP (17) IS FITTED ONLY ON THE FINAL DRIVE UNIT, LEFT SIDE.

- Remove the left bearing (18) with the specific extractor.
- Collect the inside spacer (19).
- Remove the right bearing (20) with the specific extractor.
- Retrieve the right hand spacer (21).
- Clean the inside of the hub thoroughly.

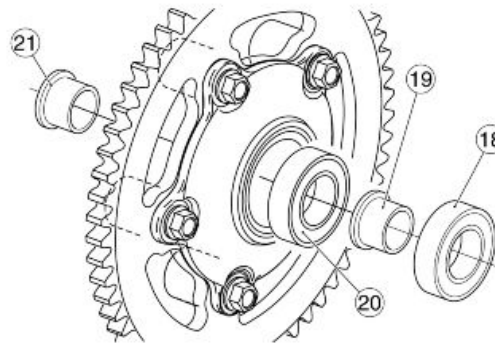

CAUTION

WASH ALL COMPONENTS WITH CLEAN DETERGENT SOLUTION.

Specific tooling

AP8140180 Bearing extractor

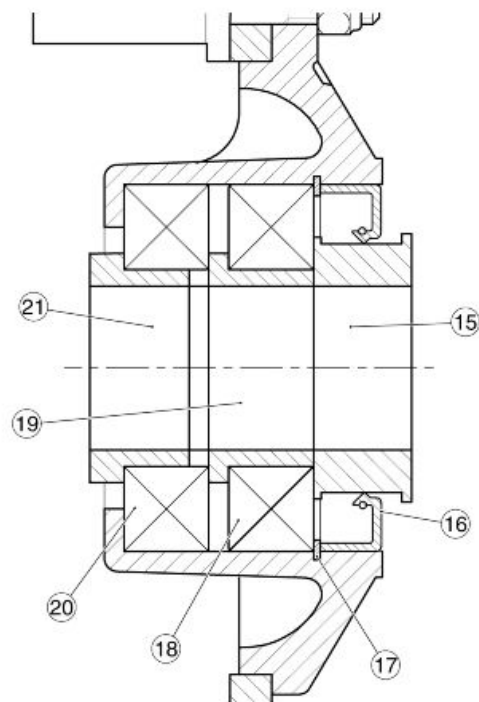

Shock absorbers

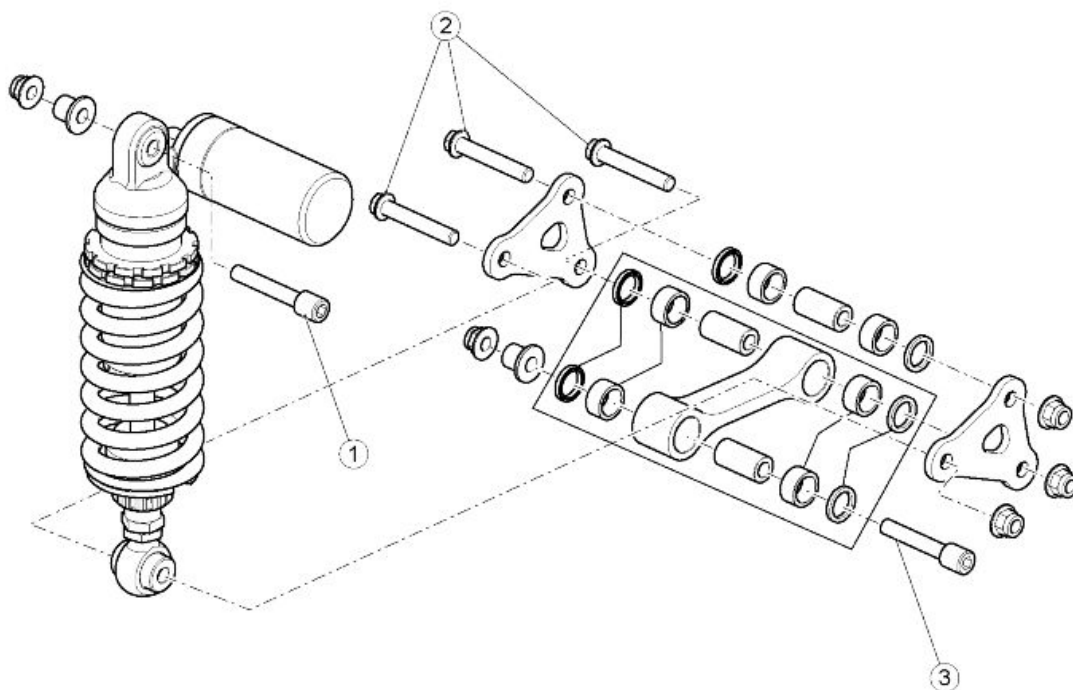
**REAR SHOCK ABSORBER**

pos.	Description	Type	Quantity	Torque	Notes
1	Upper shock absorber fixing screw	M10	1	50 Nm (36.88 lb ft)	-
2	Dual connecting rod fixing screw	M10	3	50 Nm (36.88 lb ft)	-
3	Screw fastening single connecting rod to chassis	M10	1	50 Nm (36.88 lb ft)	-

The rear suspension consists of a spring-shock absorber unit linked to the frame via uniball joints and to the swingarm via a linkage system.

To adjust the rear shock absorbers, the following adjustments can be performed:

RSV4 1000 RF

- To adjust the rebound damping, turn the knurled button (1);
- To adjust the compression damping, turn the knurled button (2);
- To adjust the spring pre-load (B), using an appropriate wrench, unscrew the locking ring nut (4) and turn the adjusting collar (3). Once the adjustment is completed, tighten the ring nut (4).

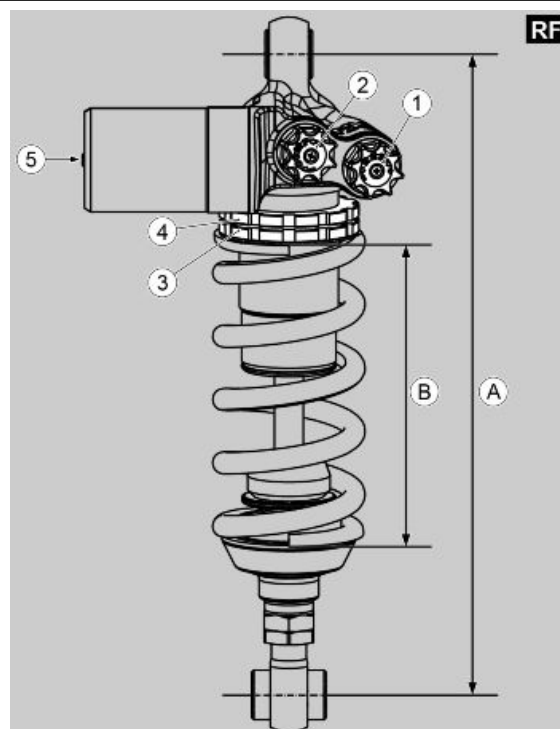



TO AVOID COMPROMISING SHOCK ABSORBER OPERATION, DO NOT LOOSEN THE SCREW (5) AND DO NOT TAMPER WITH THE SEAL UNDERNEATH, AS NITROGEN MAY COME OUT RESULTING IN RISK OF ACCIDENTS.

RSV4 1000 RR

- To adjust the rebound damping, turn the ring nut (1);
- To adjust the compression damping, turn the screw (2);
- To adjust the spring pre-load (B), using an appropriate wrench, unscrew the locking ring nut (4) and turn the adjusting collar (3). Once the adjustment is completed, tighten the ring nut (4).

NOTE

THE VEHICLE HAS A HEIGHT ADJUSTABLE SUSPENSION. FOR USE ON THE TRACK PLEASE OBSERVE THE VALUES RECOMMENDED FOR USE ON THE ROAD.

CAUTION

CARRY OUT MAINTENANCE OPERATIONS AT HALF THE INTERVALS SPECIFIED IF THE VEHICLE IS USED IN PARTICULAR RAINY OR DUSTY CONDITIONS, OFF ROAD OR FOR TRACK USE.

REAR SHOCK ABSORBER STANDARD SETTING IS ADJUSTED TO MEET SPORTING RIDING.

IN ANY CASE IT IS POSSIBLE TO INSERT PERSONAL SETTINGS, DEPENDING ON VEHICLE UTILIZATION.



RACING TRACK SETTINGS MUST BE DONE ONLY FOR OFFICIAL COMPETITIONS OR SPORTS EVENTS WHICH ARE, IN ALL CASES, AWAY FROM NORMAL ROAD TRAFFIC AND WITH THE AUTHORISATION OF THE RELEVANT AUTHORITIES.

IT IS STRICTLY FORBIDDEN TO RIDE A VEHICLE SET FOR RACING ON ROADS AND MOTORWAYS.



TO COUNT THE NUMBER OF CLICKS AND/OR REVOLUTIONS OF ADJUSTMENT SETTINGS ALWAYS START FROM THE MOST RIGID SETTING (WHOLE CLOCKWISE ROTATION OF THE SETTING).

IN ORDER TO AVOID DAMAGES DO NOT FORCE THE SET SCREWS TO TURN BEYOND THE END OF THE STROKE ON BOTH SIDES.



SET SPRING PRE-LOADING AND SHOCK ABSORBER REBOUND DAMPING ACCORDING TO THE VEHICLE USE CONDITIONS.

IF THE SPRING PRE-LOADING IS INCREASED, IT IS NECESSARY TO INCREASE THE REBOUND DAMPING ACCORDINGLY TO AVOID SUDDEN JERKS WHEN RIDING.

CAUTION

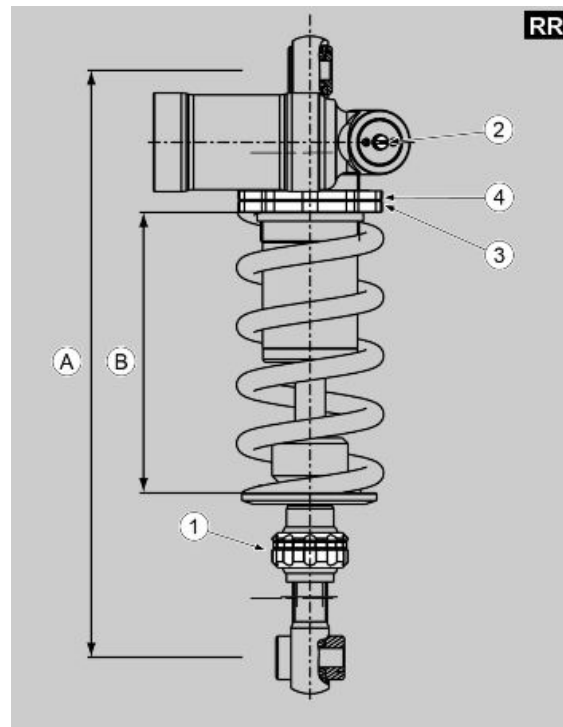

ALWAYS OBSERVE THE RECOMMENDED ADJUSTMENT RANGE.

CAUTION

CONSULT THE "SETTING UP" PARAGRAPH FOR THE PARAMETER SETTINGS.

Adjusting

(PROCEDURE FOR OHLINS FORKS)



SPORT SETTINGS MAY BE USED ONLY FOR OFFICIAL COMPETITIONS TO BE CARRIED OUT ON TRACKS, AWAY FROM NORMAL ROAD TRAFFIC AND WITH THE AUTHORISATION OF THE RELEVANT AUTHORITIES.

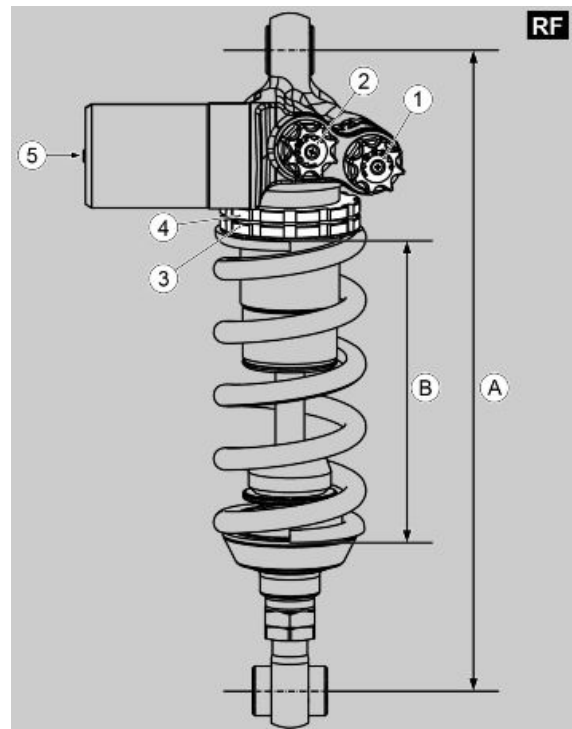

REAR SHOCK ABSORBER - RSV4 1000 RF - STANDARD ADJUSTMENT (ÖHLINS) (FOR ROAD USE ONLY)

Specification	Desc./Quantity
Shock absorber centre-to-centre distance (A)	314 mm (12.36 in)
(preloaded) Spring (B) length	146 mm (5.75 in)
Rebound adjustment, ring nut (1)	open (**) 12 clicks from fully closed (*)
Compression adjustment, knob (2)	open (**) 12 clicks from fully closed (*)

REAR SHOCK ABSORBER - RSV4 1000 RF - RACING ADJUSTMENT RANGE (ÖHLINS) (TRACK USE ONLY)

Specification	Desc./Quantity
Shock absorber centre-to-centre distance (A)	314 mm (12.36 in)
(preloaded) Spring (B) length	146 mm (5.75 in)
Rebound adjustment, ring nut (1)	from completely closed (*) open (**) 8 clicks (up to 12)
Compression adjustment, knob (2)	from completely closed (*) open (**) 6 clicks (up to 12)

(*) = clockwise

(**) = anticlockwise

(PROCEDURE FOR SACHS FORKS)



SPORT SETTINGS MAY BE USED ONLY FOR OFFICIAL COMPETITIONS TO BE CARRIED OUT ON TRACKS, AWAY FROM NORMAL ROAD TRAFFIC AND WITH THE AUTHORISATION OF THE RELEVANT AUTHORITIES.

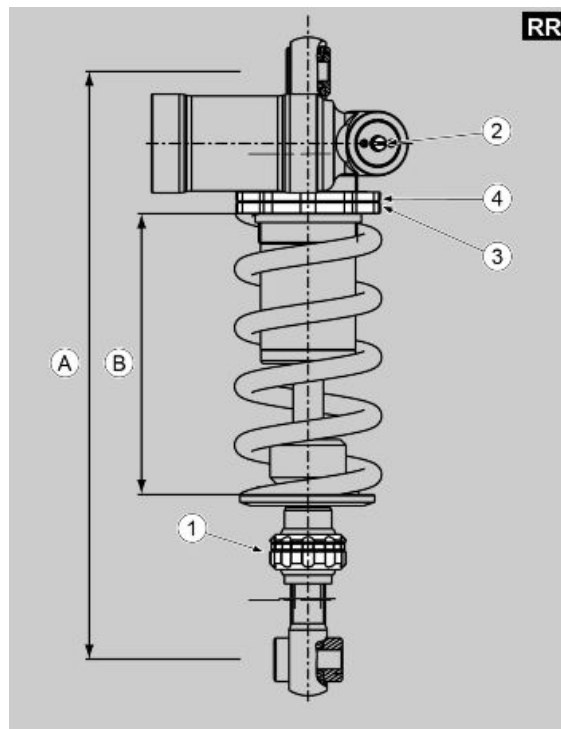

REAR SHOCK ABSORBER - RSV4 1000 RR - STANDARD ADJUSTMENT (SACHS) (FOR ROAD USE)

Specification	Desc./Quantity
Shock absorber centre-to-centre distance (A)	312 mm (12.28 in)
(preloaded) Spring (B) length	148 mm (5.83 in)
Rebound adjustment, ring nut (1)	open (**) 20 clicks from fully closed (*)
Compression adjustment, knob (2)	open (**) 2 turns from fully closed (*)

REAR SHOCK ABSORBER - RSV4 1000 RR - RACING ADJUSTMENT RANGE (SACHS) (TRACK USE ONLY)

Specification	Desc./Quantity
Shock absorber centre-to-centre distance (A)	314 mm (12.36 in)
(preloaded) Spring (B) length	144 mm (5.67 in)
Rebound adjustment, ring nut (1)	open (**) 8 clicks from fully closed (*)
Compression adjustment, knob (2)	open (**) 1-2 turns from fully closed (*)

(*) = clockwise

(**) = anticlockwise

Removing

- Secure the vehicle using a belt and hoist.
- Remove the silencer and the right hand rider footpeg.
- Unscrew and remove the lower screw and retrieve the nut.



- Unscrew and remove the screw fixing the dual linkage rod to the single linkage.
- Retrieve the nut.

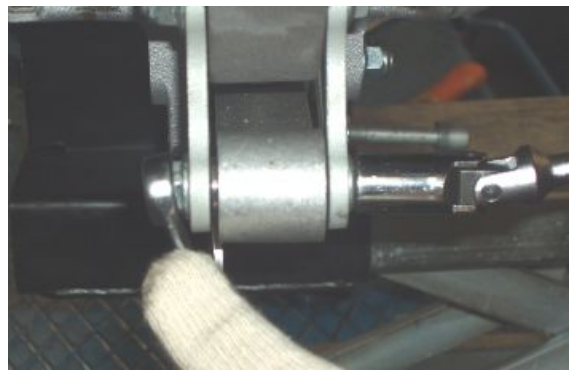

- Unscrew and remove the upper screw and retrieve the nut.
- Remove the shock absorber from the right side.



Linkages

Removing

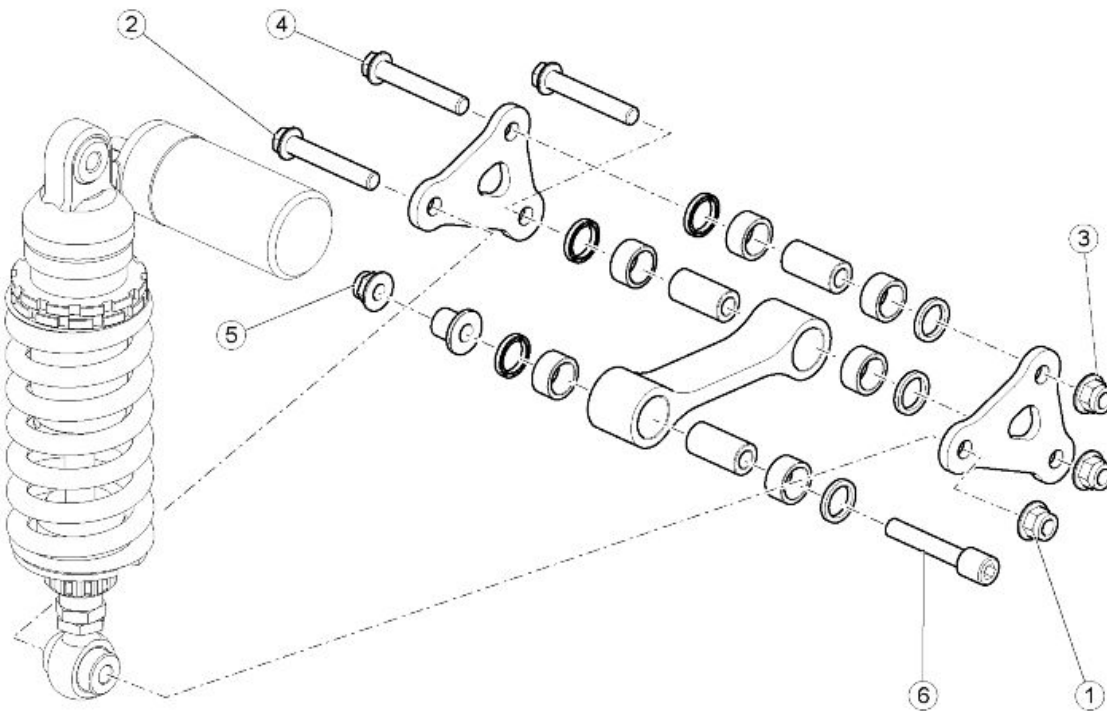

- Working from the left side of the vehicle, loosen and remove the nut (1).
- Slide off the screw (2) from the opposite side.
- Loosen and remove the nut (3).
- Slide off the screw (4) from the opposite side.
- Loosen and remove the nut (5).
- Slide off the screw (6) from the opposite side.
- Remove the complete suspension connecting rod assembly unit.

CAUTION

UPON REFITTING, GREASE THE FULCRUM POINTS ON THE CONNECTING ROD ASSEMBLY. PAY SPECIAL ATTENTION TO THE CORRECT POSITIONING OF THE PARTS AND CHECK SEVERAL TIMES THAT JOINTS MOVE SMOOTHLY.

INDEX OF TOPICS

CHASSIS

CHAS

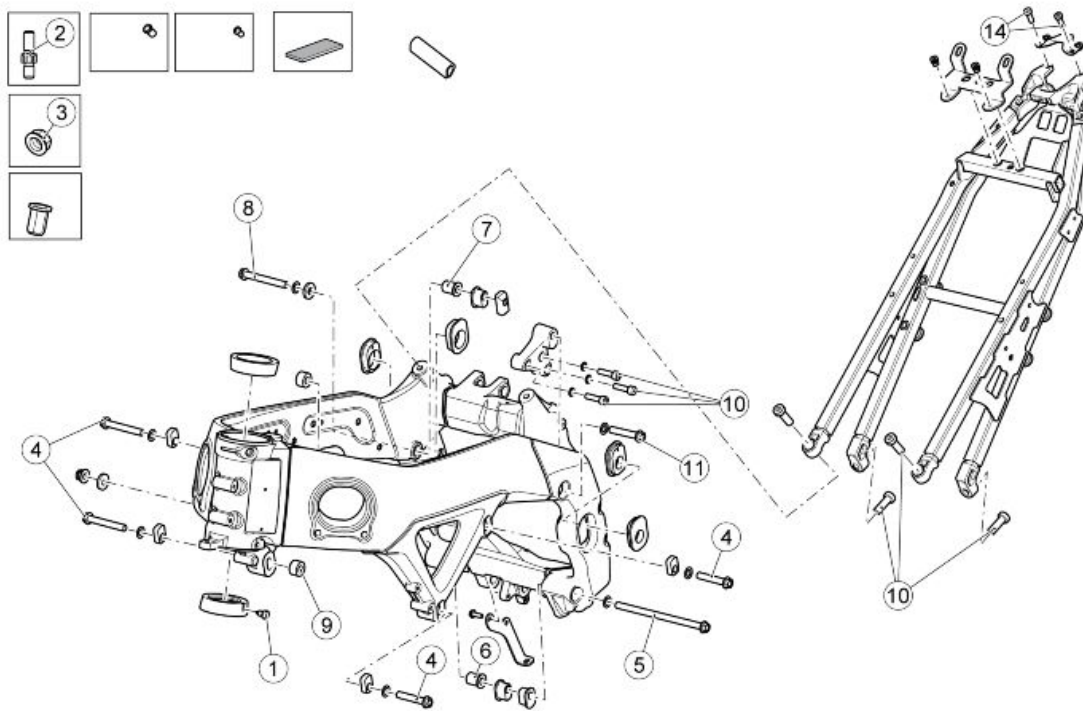
**CHASSIS**

pos.	Description	Type	Quantity	Torque	Notes
1	Headstock locator dowel	M8x1	2	10 Nm (7.37 lb ft)	-
2	Threaded intake duct fastener pins	M6	2 + 2	4 Nm (2.95 lb ft)	Loct. 243
3	Intake duct fixing nuts	M6	2 + 2	Manual	-
4	Front couplings	M10	2 + 2	50 Nm (36.88 lb ft)	-
5	Lower rear coupling	M10	1	50 Nm (36.88 lb ft)	-
6	RH lower rear regulator bushing	M18x1.5	1	12 Nm (8.85 lb ft)	-
7	RH upper rear regulator bushing	M18x1.5	1	12 Nm (8.85 lb ft)	-
8	RH upper rear coupling	M10	1	50 Nm (36.88 lb ft)	-
9	Right fairing spacer	M6	1	10 Nm (7.37 lb ft)	Loct. 243
10	Upper rear left hand engine mount fastener screws	M8	3	25 Nm (18.44 lb ft)	-
11	Upper rear mount	M10	1	50 Nm (36.88 lb ft)	-
12	Saddle mounting fixing screws	M10	4	50 Nm (36.88 lb ft)	-
13	Passenger saddle and saddle cover catch plate fixing screws	M6	2	8 Nm (5.9 lb ft)	-
14	Taillight mounting bracket fixing screws	M5	2	4 Nm (2.95 lb ft)	-
-	Screw fastening the ground cable to the left side chassis	M6	1	6 Nm (4.42 lb ft)	-
-	Screws fastening oil radiator mounting bracket to engine	M6	2	8 Nm (5.9 lb ft)	-

Swinging arm

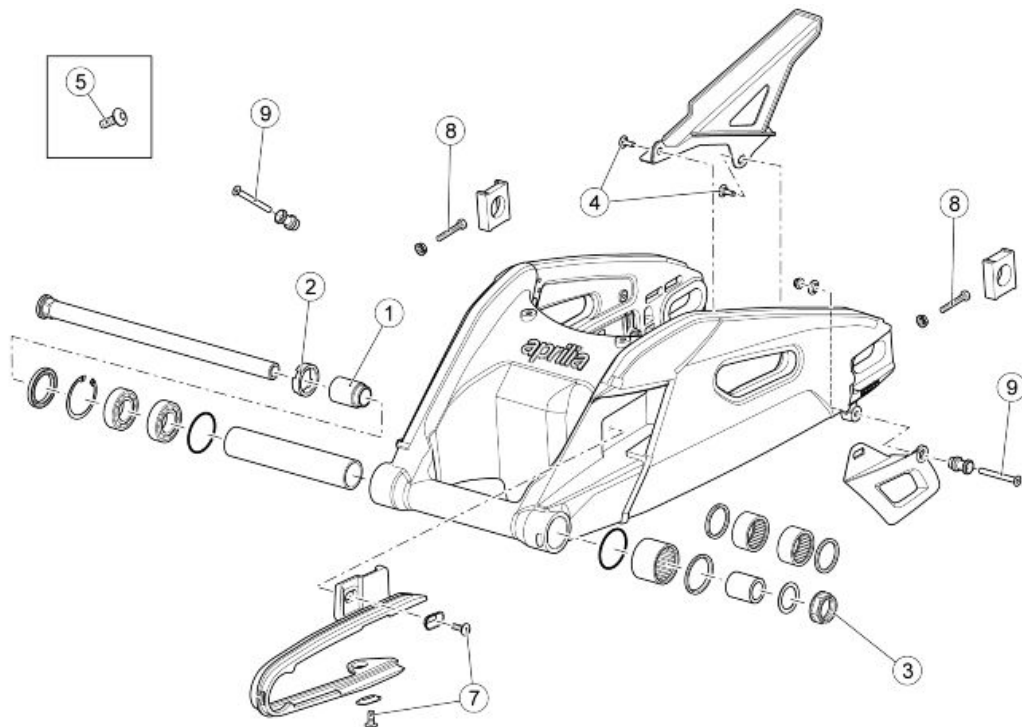
**REAR SWINGARM**

pos.	Description	Type	Quantity	Torque	Notes
1	Swingarm regulator bushing	M30x1.5	1	12 Nm (8.85 lb ft)	-
2	Swingarm ferrule	M30x1.5	1	60 Nm (44.25 lb ft)	-
3	Fork pin nut	M20x1.5	1	65 Nm (47.94 lb ft)	AGIP GREASE SM2
4	Chain guard fastening screws	M5	2	4 Nm (2.95 lb ft)	-
5	Front chain guide fixing screw	M5	1	4 Nm (2.95 lb ft)	-
6	Chain guide rear fastening nut	M6	1	7 Nm (5.16 lb ft)	-
7	Chain feeder shoe fastening screws	M5	2	2 Nm (1.48 lb ft)	-
8	Chain tensioner fastener screw	M8	2	Manual	-
9	Rear stand bushing fastening screws	M6	2	7 Nm (5.16 lb ft)	-
-	Lower chain shoe fastening screws	M6	2	10 Nm (7.38 lb ft)	-

Removing

- Remove the exhaust system.
- Remove the rear mudguard.
- Remove the rear shock absorber.
- Remove the rear wheel.
- Secure the rear part of the vehicle with a belt and a hoist.
- Unscrew and remove the two pipe grommet screws.
- Remove the rear brake calliper off the swingarm.



- Unscrew and remove the three screws and remove the pinion cover.

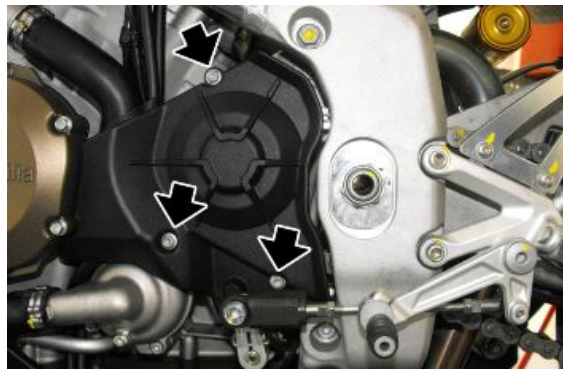

- Unscrew and remove the screw and retrieve the washer.
- Slide off the pinion from the chain and remove.



- Unscrew and remove the nut and retrieve the washer.



- Working from the right side, loosen and remove the locking ring nut.



- Turn the swingarm pin (2) anticlockwise, which turns and loosens the adjustment bushing (3) completely.



REMOVAL SHOULD BE CARRIED OUT WITH UTMOST CAUTION. SUPPORT THE SWINGARM FROM THE FRONT TO AVOID ACCIDENTAL FALLS. PLACE A WOODEN SUPPORT UNDER THE FRONT PART OF THE REAR SWINGARM TO PREVENT IT FROM LOWERING AND TO KEEP IT UPRIGHT.

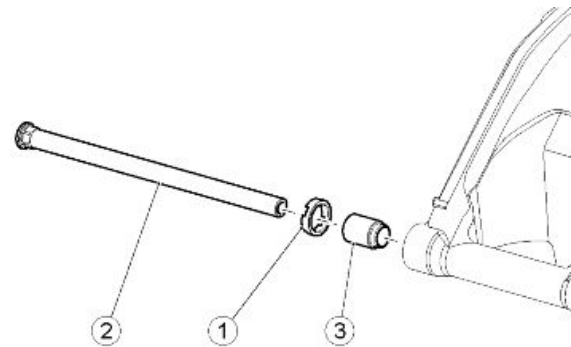
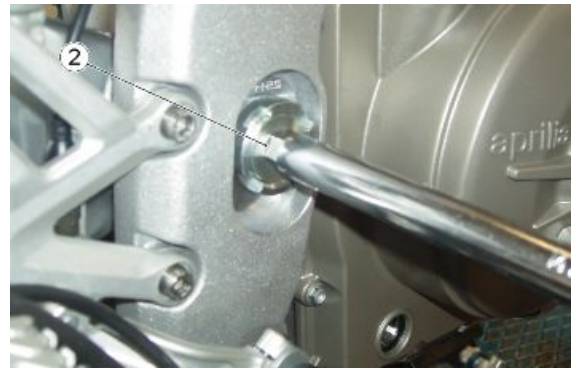

- Place a mounting under the front part of the swingarm.
- Support the swingarm from the front.
- Remove the swingarm pin (2) from the right hand side.
- Support the front part of the swingarm and be ready to accompany it.
- Using the rear mounting stand, remove the swingarm completely from the vehicle from the rear.
- Remove the adjustment bushing from the swingarm pin (2).



UPON REMOVING THE REAR SWINGARM PAY ATTENTION NOT TO JAM THE GEARING CHAIN.

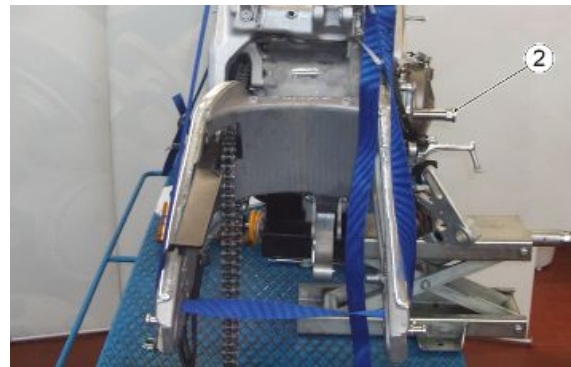

- If necessary, use a specific tool to remove a pin from the drive chain.
- Open and remove the chain.



Checking

- Remove the swingarm.
- Clean the two sides of the bearing seats with a cloth.
- Slide off the bushing (1).
- Remove the sealing gasket (2).
- Remove the sealing gasket (3).
- Remove the circlip (4).
- Use the specific special tool to extract the two bearings (5) and the roller bearing (6).

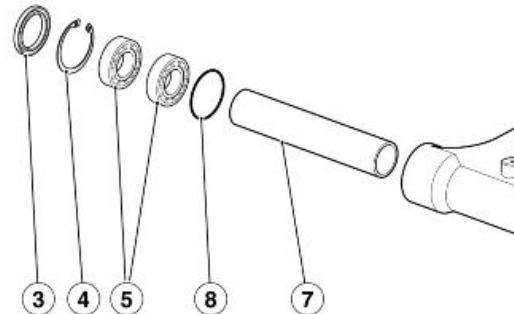
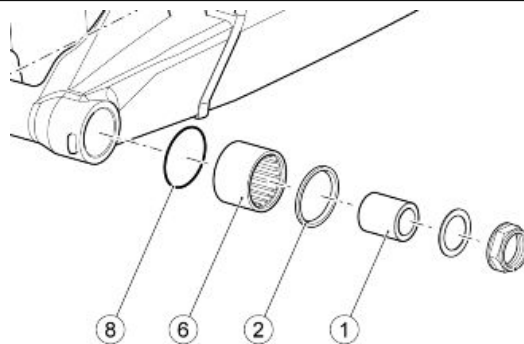

CHECK AND, IF REQUIRED, REPLACE THE BEARINGS AFTER EVERY BEARING REMOVAL.

Specific tooling

AP8140180 Bearing extractor

- Remove the inner spacer (7) and collect the two OR seals (8).
- Carefully clean inside the bearing seat.

CAUTION

WASH ALL COMPONENTS WITH CLEAN DETERGENT SOLUTION.



UPON REFITTING, USE A BUFFER WITH A DIAMETER EQUAL TO THE EXTERNAL RING OF THE BEARINGS TO INSERT THE BEARINGS. DO NOT HIT THE BALLS AND/OR THE INTERNAL RING.



CHECK THE CONDITION OF ALL COMPONENTS AND OF THE COMPONENTS INDICATED AS FOLLOWS IN PARTICULAR.

SWINGARM BEARINGS

Carry out the check with the bearings fitted on the swingarm.

ROTATION CHECK

- Manually rotate the inside ring of each bearing. Rotation must be constant, smooth and noiseless.

If one or both bearings do not fall within the control parameters:

- Replace both swingarm bearings.

RADIAL AND AXIAL CLEARANCE CHECK

- Check the radial and axial clearance.

Axial clearance: a minimum axial clearance is allowed.

Radial clearance: none.

If one or both bearings do not fall within the control parameters:

- Replace both swingarm bearings.



ALWAYS REPLACE BOTH BEARINGS.

ALWAYS REPLACE THE BEARINGS WITH COMPONENTS OF THE SAME TYPE.

SWINGARM SEALS

- Check that the gaskets are in good conditions; replace them if they show signs of damage or excessive wear.



ALWAYS REPLACE BOTH SEALS TOGETHER.

ALWAYS REPLACE THE SEALS WITH COMPONENTS OF THE SAME TYPE.

SWINGARM PIN

- Use a dial gauge to check the swingarm pin eccentricity. If the eccentricity exceeds the limit value, replace the swingarm pin.

Maximum eccentricity: 0.3 mm (0.012 in)

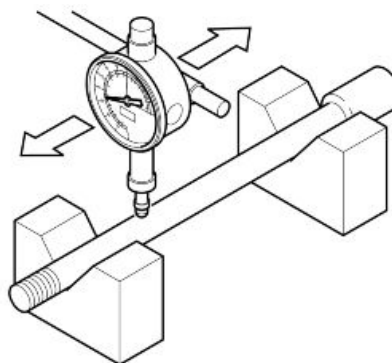

Installing

NOTE

ADJUSTMENT OF THE SWINGARM HEIGHT ON THE FRAME IS ONLY POSSIBLE FOR THE FACTORY MODEL.

The height of the swingarm pin relative to the chassis is adjusted with special inserts installed in the respective seats in the chassis. The hole is offset by -5 mm (-0.197 in) relative to the centreline of the insert, as a result the swingarm is in the low position.

There are four inserts, subdivided as follows:

- Inner/outer
- Right/left



THE TWO LEFT SIDE SWINGARM PIN INSERTS ARE THE SAME. THE TWO RIGHT SIDE SWINGARM PIN INSERTS ARE DIFFERENT.

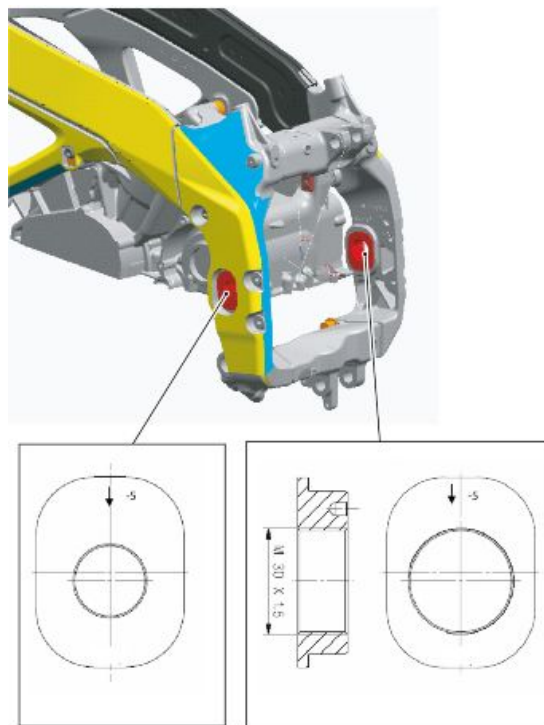

- Refit the swingarm height adjustment inserts if removed, bearing in mind that the arrow must face downward.

WARNING

PAY PARTICULAR ATTENTION TO THE DIRECTION OF THE INSERTS WHEN REFITTING. INCORRECT ASSEMBLY MAY CAUSE SEVERE DAMAGE TO THE VEHICLE. THE ARROW MUST FACE DOWNWARD.

- Spread a thin layer of lubricating grease all along the swingarm pin.
- Fit the adjustment bushing (3) to its seat and tighten it manually.

CAUTION

THE ADJUSTMENT BUSHING (3) MUST NOT PROTRUDE BEYOND THE CHASSIS INTERNAL EDGE.

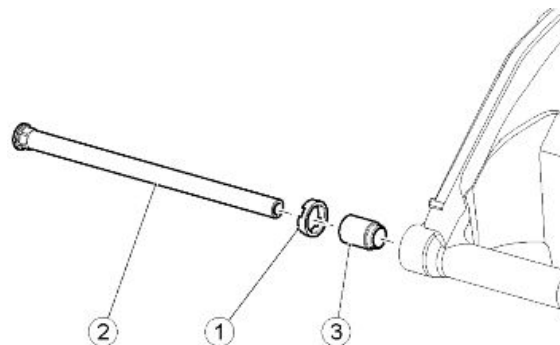

- Place a wooden support under the front of the swingarm to prevent it from dropping and hold in position.
- Support the swingarm from the front; move it into position so that the holes are aligned and simultaneously insert the pin (2) fully.

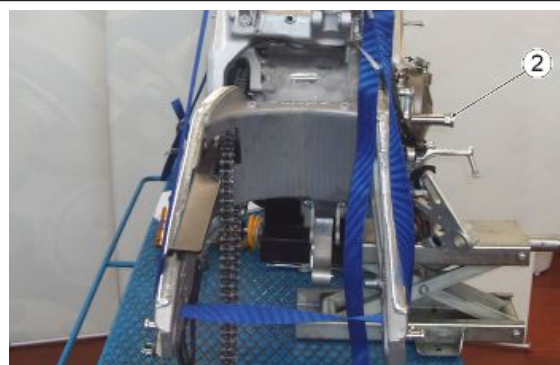

- Ensure that the hexagonal area on the pin head (2) is inserted correctly in the hexagonal seat inside the adjustment bushing (3).
 - Fit and hand-tighten the counter-lock ring nut by a few turns (1).
-
- Put some grease on the swingarm pin nut as indicated



- Fit the washer and the swingarm pin fixing nut on the pin and hand-tighten the nut.
-
- Working from the right hand side of the vehicle, turn the swingarm pin (2) clockwise. This turns the adjustment bushing (3), driving the swingarm in until fully seated.

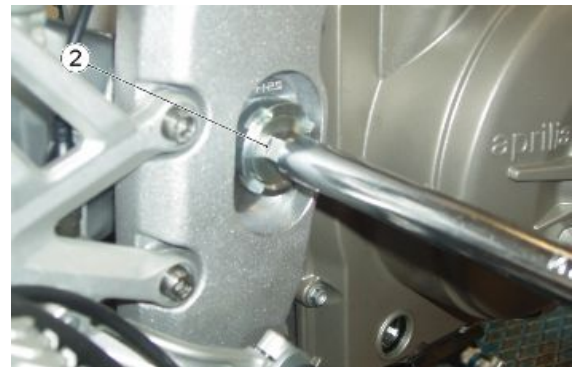

-
- Tighten the locking ring nut (1).

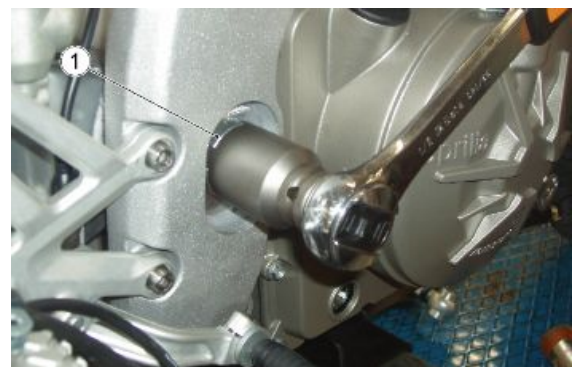

- Screw the nut.



- Refit the chain on the drive pinion

CAUTION

APPLY LOCTITE ANTI-SEIZE ON THE INTERNAL TOOTHING OF THE TRANSMISSION PINION.



- Fit the pinion and the chain on the shaft.

CAUTION

APPLY LOCTITE 243 ON THE SCREW THREAD.

- Fit the washer on the screw
- Tighten the screw.



- Install the rear shock absorber and the linkages.
- Fit the rear brake calliper plate.
- Fasten the two pipe grommets on the swingarm

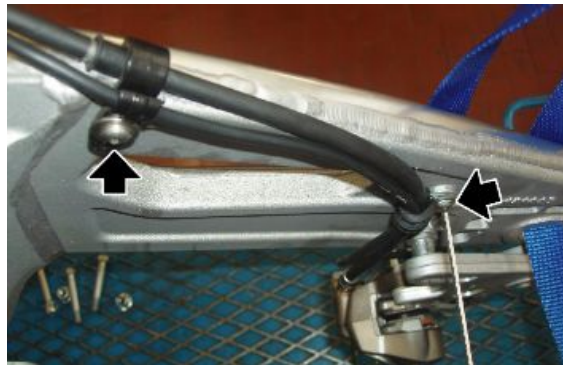

- Install the rear wheel and the exhaust system.
- Fit the pinion casing.
- Adjust the chain tension

Drive chain

Removing

The transmission chain, although "closed", has a different coloured hammerlock (where provided), which should be used to perform opening / disassembling procedures.

NOTE

WHERE PRESENT, THE HAMMERLOCK (1) MAY ALSO BE IDENTIFIED BY A SIGN (2) APPLIED IN THE MOUNTING LINES DURING MANUFACTURING.

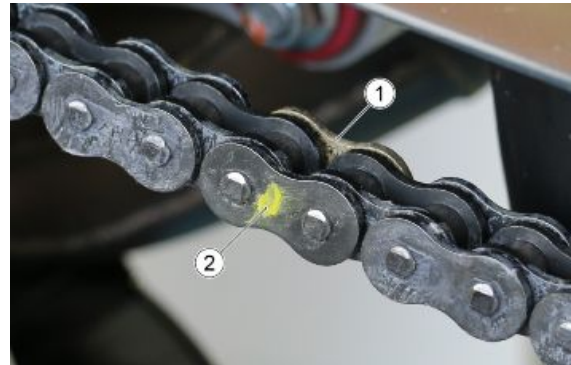

To dismantle and remove the chain, proceed as follows:

- Partially remove the pins (3) using a generic chain breaker.

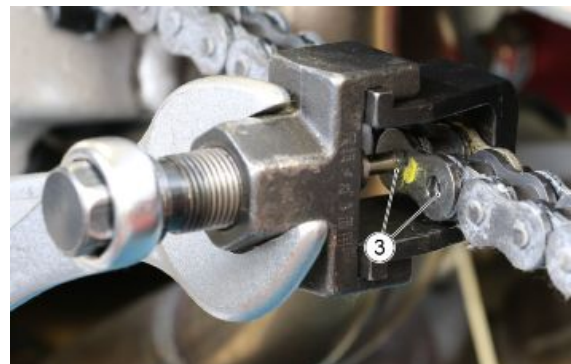

- Remove the outer plate (4).



- Remove the outer O-ring rings (5).



- Remove the inner plate (6).

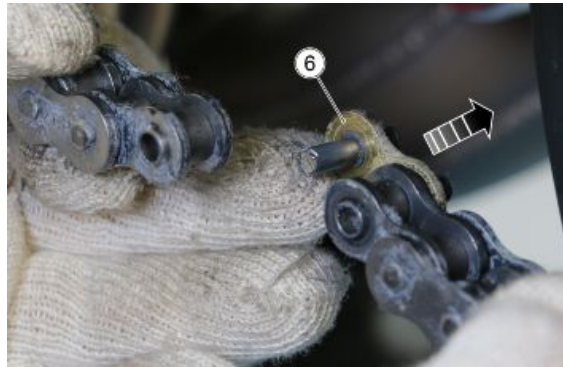

- Collect the inner O-ring rings (7) and completely remove the transmission chain.

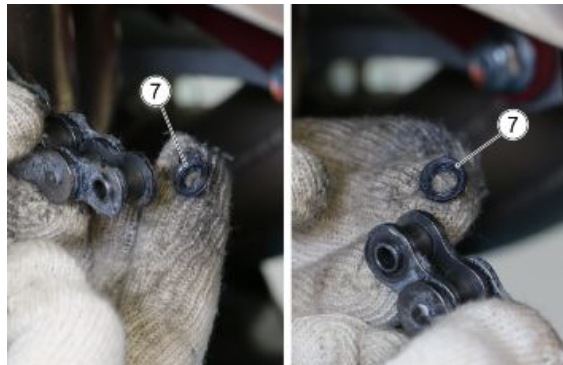

inspection

To check the wear of the drive chain, use the chain checking instrument, P/N: **Ognibene - 529510001**.

The different chain pitches which may be checked with the instrument are indicated on the instrument itself. There are three reference markings for each chain pitch indicated on the instrument. These indicate (from right to left) the correct measurements for:

1. New chain with length near nominal value;



2. Chain with chain stretch of 1.5%;
3. Chain with chain stretch of 3%, which must therefore be replaced in accordance with applicable legislation.

Perform the procedure described as follows to check chain wear:

- Tauten the chain.
- Place the jaws of the tool on the rollers at the opposite ends of a STRAIGHT length of chain consisting of 8 chain links.
- Check that the notch on the sliding jaw matches the correct marking on the instrument.



Installing

- After fitting the chain on the pinion and on the crown, put the inner O-rings (1) back onto the hammerlock pins (2) and connect the two ends of the transmission chain.

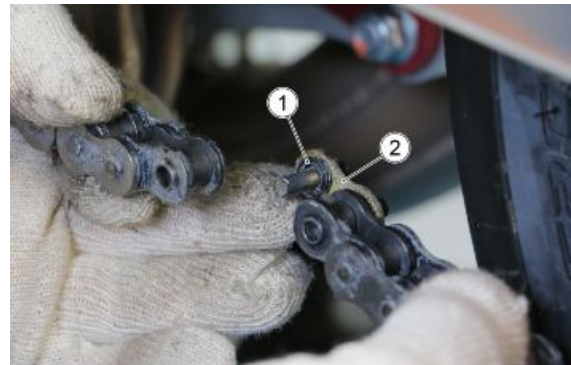

- Place the outer O-rings (3) on the pins.

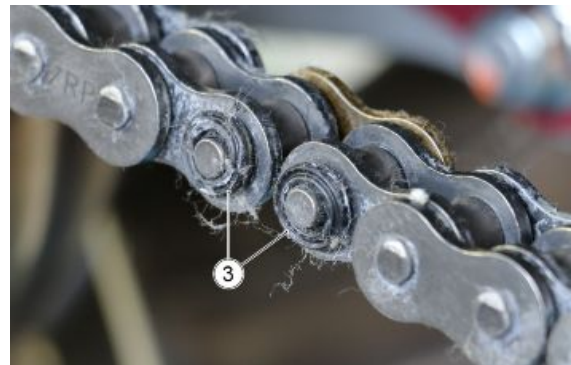

- Compress the outer plate (4) using the appropriate generic tool.

CAUTION

BE CAREFUL NOT TO COMPRESS TOO THE OUTER PLATE TOO MUCH AS THIS COULD SEIZE THE CHAIN.



- Check that the links in the transmission chain are not seized and that it can move in both directions.



- Use a generic clincher to re-tighten the pins of the link (checking riveting at points "A").

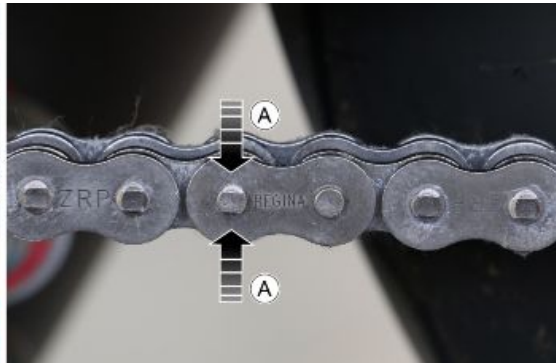

- Turn the pin of the specific tool 90° and re-engage the link pin again (checking riveting at points "B").
- Grease the chain and record the clearance.

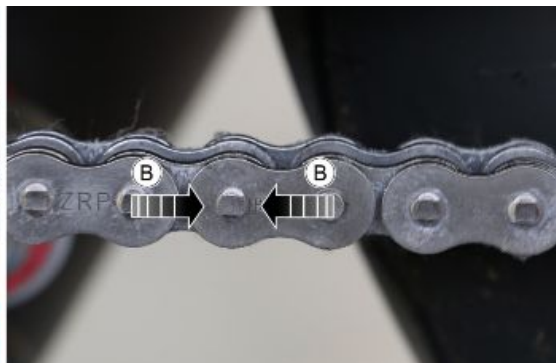

Adjusting

The vehicle has an endless chain, without master link.

NOTE

CARRY OUT MAINTENANCE OPERATIONS AT HALF THE INTERVALS SPECIFIED IF THE VEHICLE IS USED IN PARTICULAR RAINY OR DUSTY CONDITIONS, OFF ROAD OR FOR TRACK USE.

CLEARANCE CHECK

To check the clearance:

- Shut off the engine.
- Rest the vehicle on its stand.
- Select neutral.
- Check that the vertical oscillation at a point between the pinion and the sprocket on the lower branch of the chain is about 30 mm (1.18 in).
- Move the vehicle forward in order to check the vertical oscillation of the chain also in other positions; the chain deflection must be constant throughout the entire rotation of the wheel.

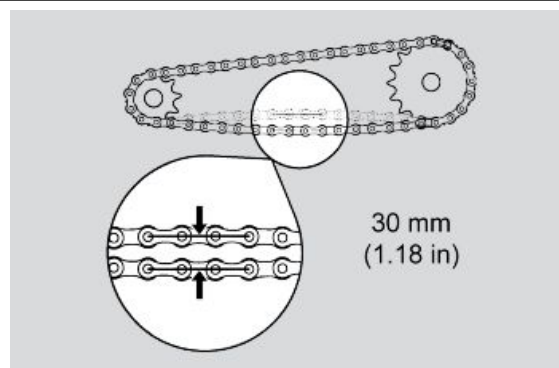

ADJUSTMENT

CAUTION

TO ADJUST THE CHAIN GET A SPECIFIC REAR SERVICE STAND.

If you need to adjust the chain tension after the check:

- Place the vehicle on its rear service stand.
- Loosen the nut (1) completely.
- Loosen the two lock nuts (4).
- Use the adjuster screw (5) to adjust the chain clearance checking that the references (2-3) match on both sides of the vehicle.
- Tighten the two lock nuts (4).
- Tighten the nut (1).
- Check the chain clearance.



CAUTION

THERE ARE TWO FIXED REFERENCES (2-3) FOR WHEEL CENTRING THAT CAN BE FOUND ON THE SWINGARM.

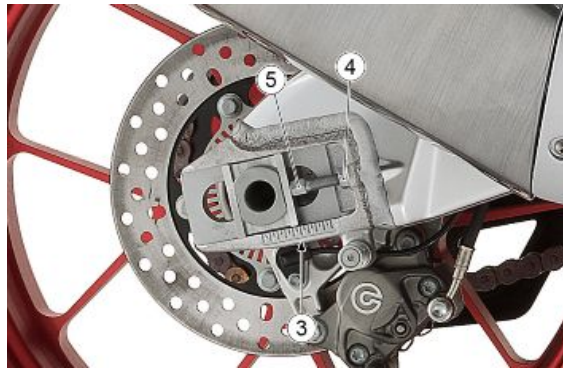

CHECKING WEAR OF CHAIN, PINION AND SPROCKET

Also regularly check the following parts and make sure that the chain, the pinion and the sprocket do not show:

- damaged rollers;
- loosened pins;
- dry, rusty, flattened or jammed chain links;
- excessive wear;
- missing sealing rings;
- excessively worn or damaged pinion or sprocket teeth;



IF THE CHAIN ROLLERS ARE DAMAGED, THE PINS ARE LOOSE AND/OR THE SEAL RINGS ARE DAMAGED OR MISSING, THE ENTIRE CHAIN UNIT (PINION, SPROCKET AND CHAIN) NEEDS TO BE REPLACED.

LUBRICATE THE CHAIN REGULARLY, ESPECIALLY IF THERE ARE DRY OR RUSTY PARTS. CRUSHED OR SEIZED LINKS MUST BE LUBRICATED AND RESTORED TO PROPER WORKING ORDER.



THE DRIVE CHAIN HAS SEAL RINGS BETWEEN THE LINKS, WHICH KEEP THE GREASE INSIDE. BE EXTREMELY CAREFUL WHEN ADJUSTING, LUBRICATING, WASHING AND REPLACING THE CHAIN.

CLEANING AND LUBRICATION

Do not wash the chain with water jets, vapour jets, high-pressure water jets and highly flammable solvents.

- Wash the chain with naphtha or kerosene. If it tends to rust quickly, carry out the maintenance operations more frequently.

Lubricate the chain at the intervals shown in the routine maintenance table and whenever necessary.

- After washing and drying the chain, lubricate it with spray grease for sealed chains.

Chain sliders

- Place the vehicle on its OPTIONAL rear service stand.
- Check that the pad (1) is not worn or damaged. Replace it with a new one if it is.
- Check the chain guide (2) for wear.

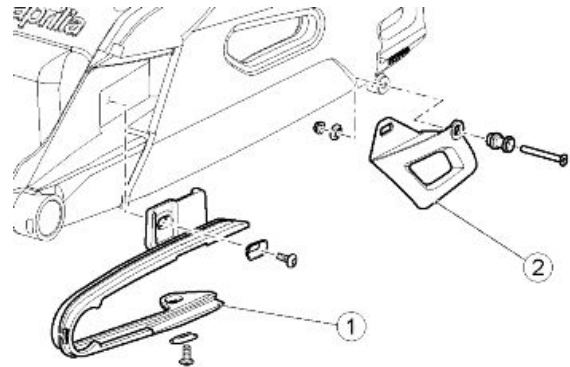

- Unscrew and remove the two screws from the left rider footpeg protection.

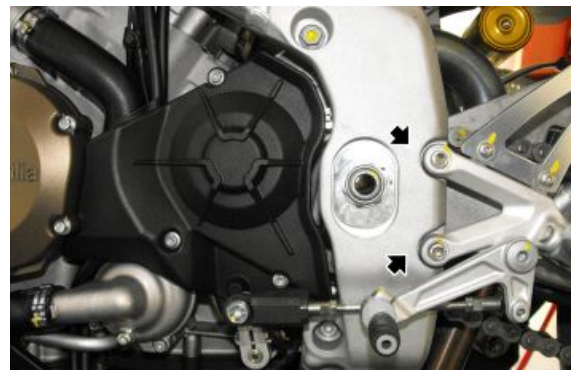

- Remove the rear wheel.
- Unscrew and remove the upper screw fixing the chain slider and retrieve the washer.



See also

[Removing the rear wheel](#)

- Unscrew and remove the lower screw fixing the chain pad and retrieve the washers.



- Remove the chain skid (1).

Stand

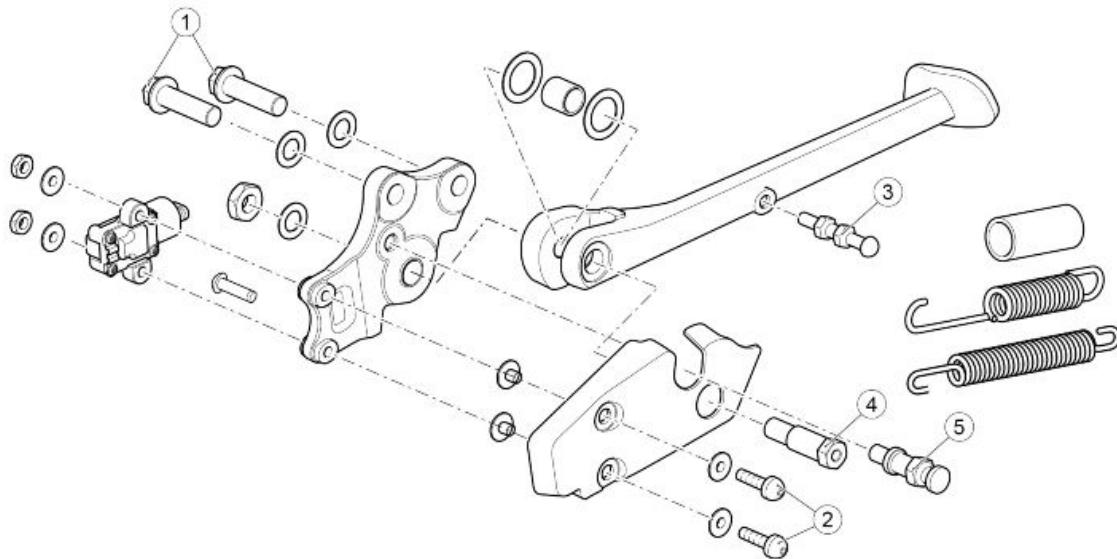

SIDE STAND

Pos.	Description	Type	Quantity	Torque	Notes
1	Screws for fastening the stand to the frame	M10	2	45 Nm (33.19 lb ft)	Loct. 243
2	Linear switch retaining screws and nuts	M5	2	4 Nm (2.95 lb ft)	-
3	- Spring retaining pin on stand	-	1	10 Nm (7.38 lb ft)	Loct. 243
4	Stand fastening pin	-	1	15 Nm (11.06 lb ft)	Loct. 243
5	Pin for retaining springs on stand pin	-	1	22 Nm (16.23 lb ft)	Loct. 243
-	Rear stand bushing retaining screw	M6	2	7 Nm (5.16 lb ft)	-

Side stand

- Remove the fuel tank.
- Remove the pinion cover.

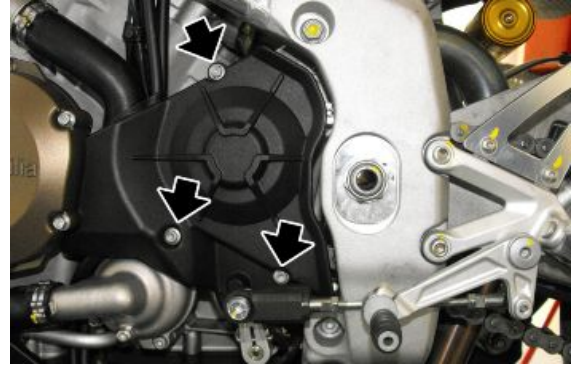

- Remove the clamps.

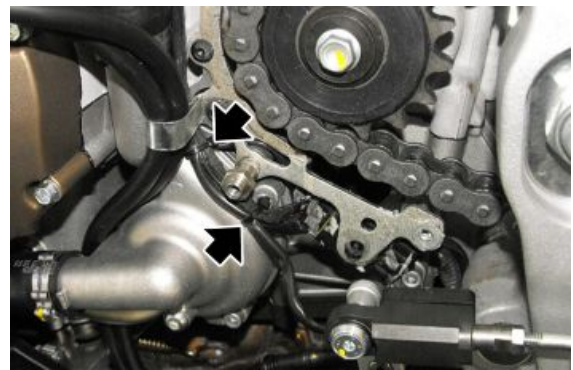

- Disconnect the stand connector.



-
- Unscrew and remove the two screws.

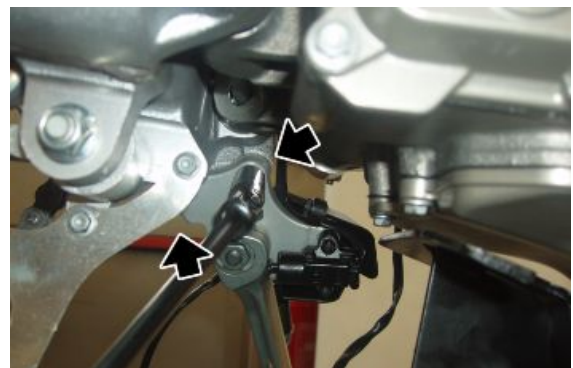

- Remove the side stand.
-

Exhaust

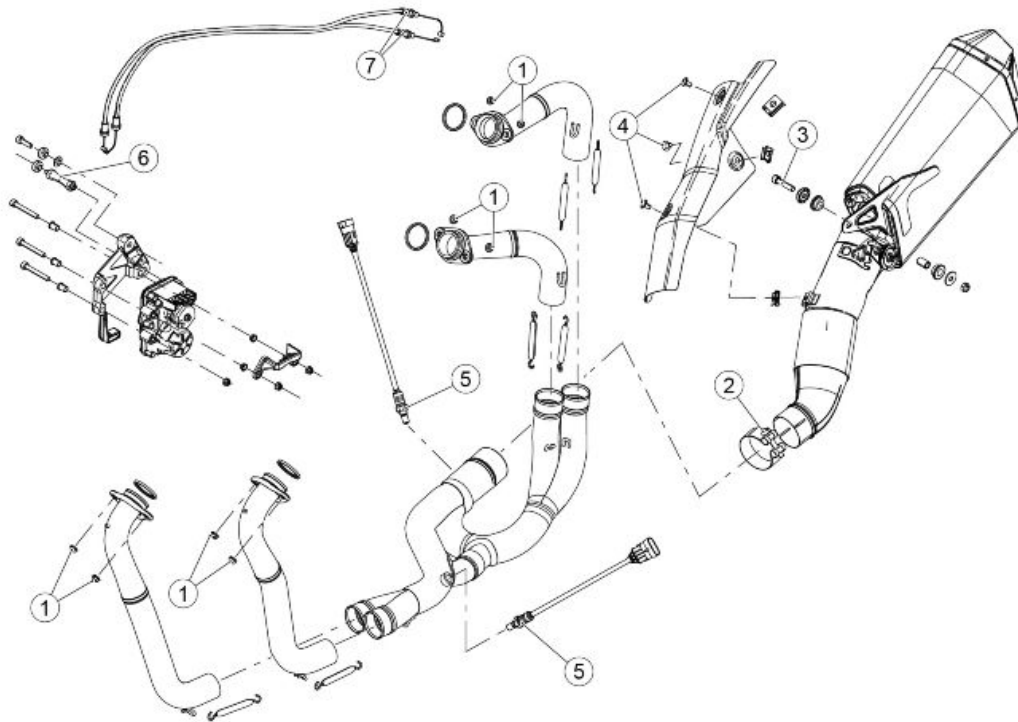

EXHAUST

Pos.	Description	Type	Quantity	Torque	Notes
1	Exhaust manifold flange fastening nuts	M7	8	13 Nm (9.59 lb ft)	-
2	Silencer clamp fastening screw - central manifold	M8	1	20 Nm (14.75 lb ft)	-
3	Screw used to secure the silencer to the RH footrest support	M8	1	25 Nm (18.44 lb ft)	-
4	Torx button head silencer aesthetic protection fastening screw	M6x10	3	8 Nm (5.90 lb ft)	-
5	Lambda probe fastener	-	2	18 Nm (13.28 lb ft)	-
6	RH fairing spacer	M6	1	8 Nm (5.90 lb ft)	-
7	Exhaust valve opening/closing cables regulator lock-nuts	M6	2	5 Nm (3.69 lb ft)	-

Removing the tail pipe

REMOVAL

- Rest the vehicle on a rear centre stand.
- Remove the three heat shield fastening screws.

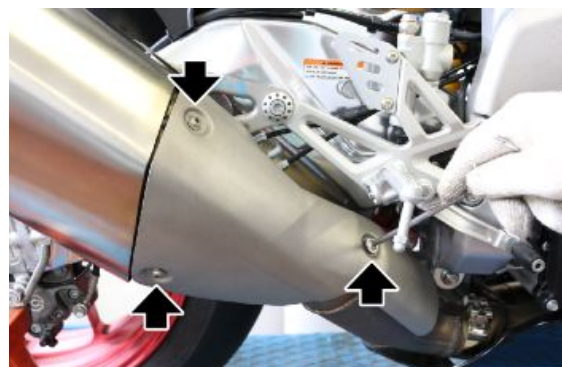

- Remove the heat shield, taking care not to lose the washers.



- Loosen the clamp between the exhaust terminal and the central manifold.



- Remove the screw together with the nut that fastens the exhaust to the frame, taking care not to lose the collar and washer.



- Rotate the exhaust terminal outwards slightly and remove the exhaust valve control cables.



- Remove the exhaust terminal.



INSTALLATION

- Fit the exhaust terminal on the central manifold.



- Connect the exhaust valve cables.



- Tighten the screw together with the nut that fastens the exhaust to the frame (taking care to insert the collar and washer).



- Tighten the clamp between the exhaust terminal and the central manifold.



- Carry out the "ADJUST PLAY ON EXHAUST VALVE CABLES" procedure in the "EXHAUST VALVE" section of the chapter "ELECTRICAL SYSTEM".
- Position the protection plate and fasten it to the exhaust terminal using the three screws.

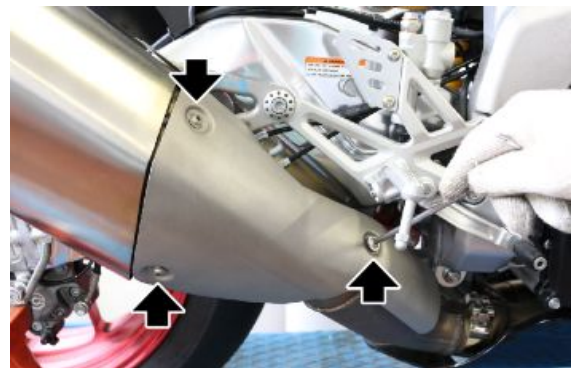

Removing the catalytic converter

- Remove the exhaust end.
- Remove the front exhaust manifold.
- Remove the pinion crankcase
- Disconnect the lambda sensor connector.
- Release the oxygen sensor cable harness from the clamps.



- Unscrew and remove the screw from the cable grommet for the two exhaust butterfly valve control cables.

CAUTION

ON REASSEMBLY, POSITION AND TIGHTEN THE SCREW BUT NOT THE CABLE GROMMET.



- Release the springs between the rear exhaust manifolds and the catalytic converter
- Remove the catalytic converter.

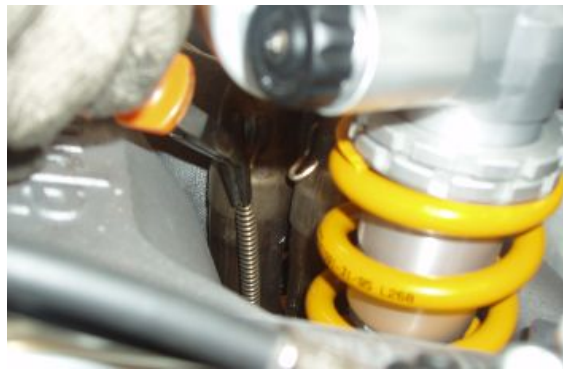

Removing the exhaust manifold

2 IN 1 FRONT EXHAUST MANIFOLD

- Remove the front underfairings.
- Remove the hand grip position sensor control unit.
- Unscrew and remove both radiator upper fixing screws.

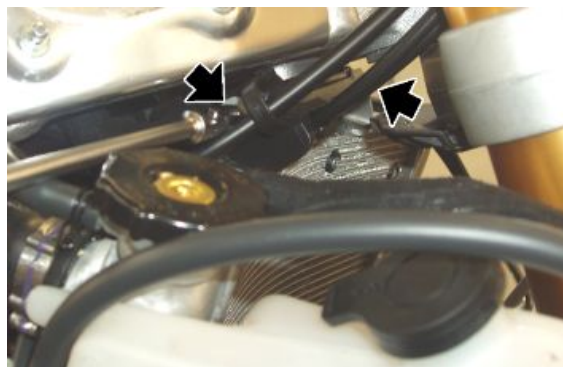

See also

[Fairing mounting panels](#)

[Twistgrip position sensor](#)

- Release the springs between the front exhaust manifolds and the catalytic converter



- Move the radiator forward.
- Unscrew and remove the four nuts fastening the front exhaust manifold and retrieve the washers.



- Remove the front exhaust manifold.



REAR EXHAUST MANIFOLDS

- Remove the catalytic converter.
- Remove the left rider footpeg.
- Unscrew and remove the four nuts fastening the rear exhaust manifolds and retrieve the washers.
- Remove both rear exhaust manifolds.



Butterfly valve in exhaust

To check correct operation and calibration of the exhaust valve, see electrical system section.

Engine oil cooler

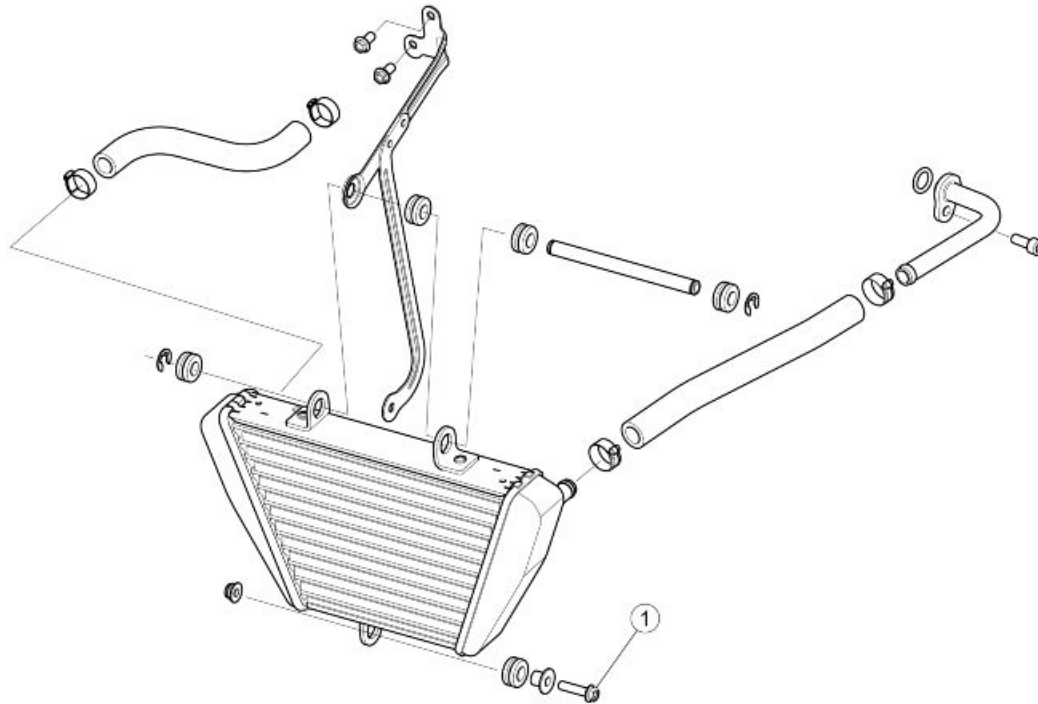

RADIATORE OLIO

Pos.	Descrizione	Tipo	Quantità	Coppia	Note
1	Screws fastening oil radiator to mounting bracket	M6	1	7 Nm (5.16 lb ft)	-
2	Viti TE fl. per fissaggio staffa a telaio	M6x20	2	10 Nm (7.38 lbf ft)	-

Removing

- Drain the engine oil.
- Remove both fairings and the radiator cowl.
- Release the clamp and disconnect the right hand radiator pipe.

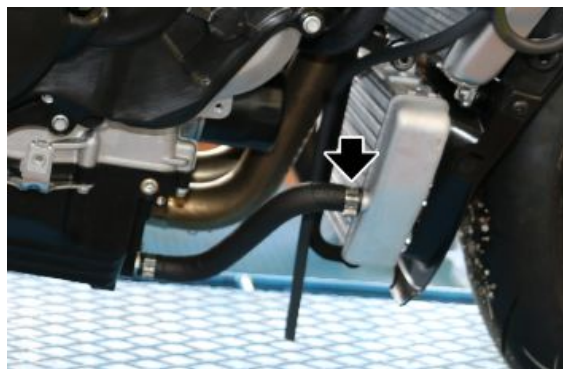

- Release the clamp and disconnect the left hand radiator pipe.

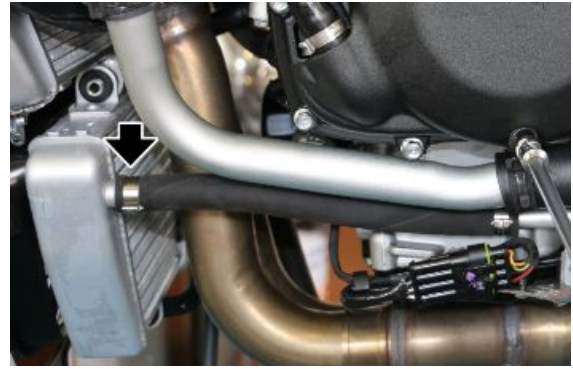
**See also**[Replacement](#)

- Remove the split pin.
- From the opposite site, remove the coolant radiator-oil radiator connector pin.



- Unscrew and remove the lower radiator retainer.
- Remove the radiator, draining completely of oil.

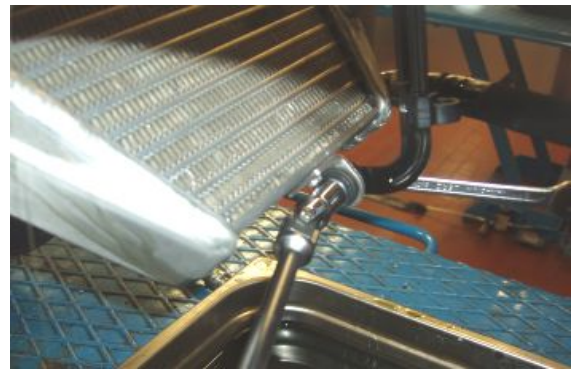

INDEX OF TOPICS

BRAKING SYSTEM

BRAK SYS

ABS

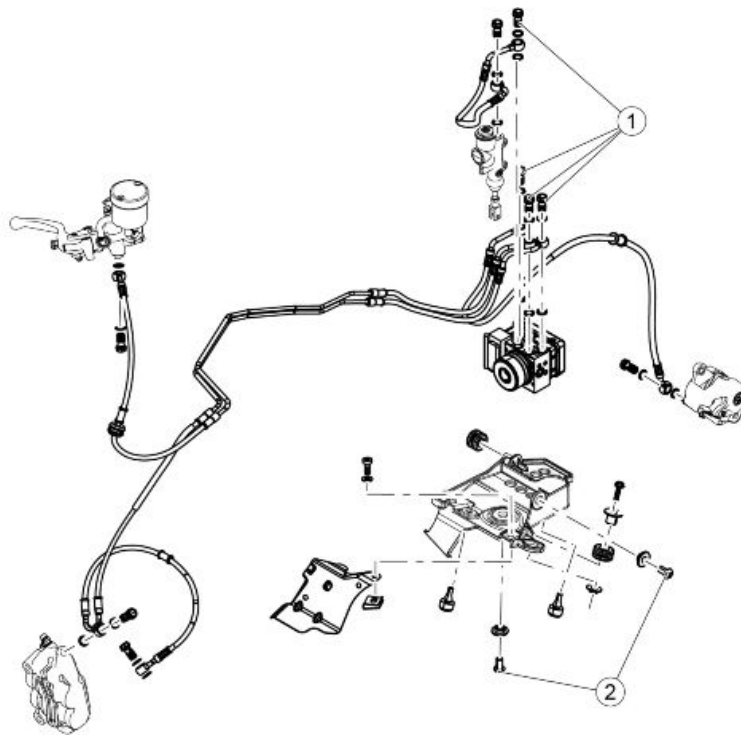

ABS CONTROL UNIT

Pos.	Description	Type	Quantity	Torque	Notes
1	Oil tube screws	M10x1	4	23-26 Nm (16.96-19.18 lb ft)	-
2	Control unit support screws	M6	2	6.8+/-1 Nm (5.01 +/-0.74 lb ft)	-

Operating diagram

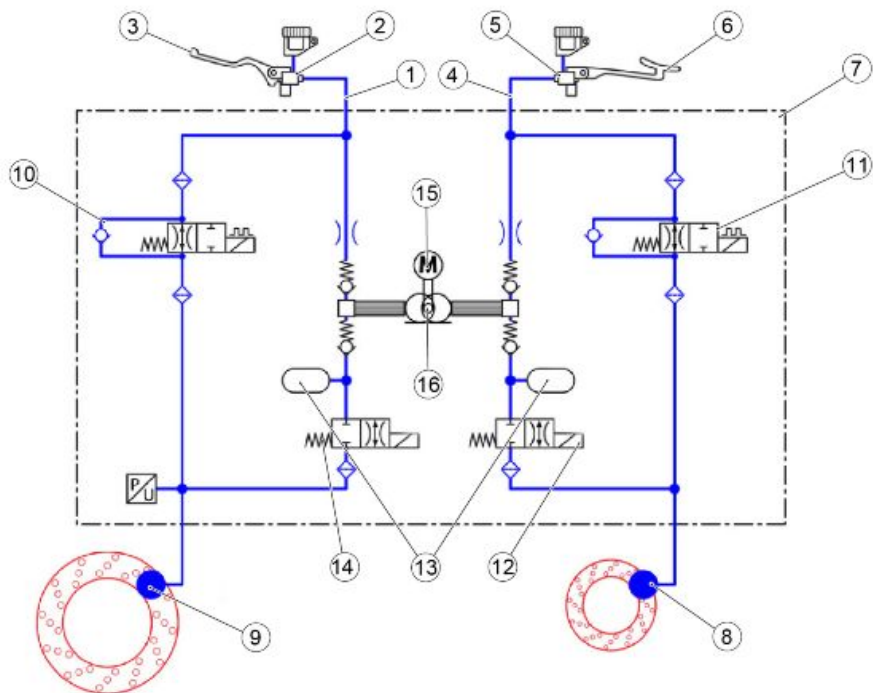
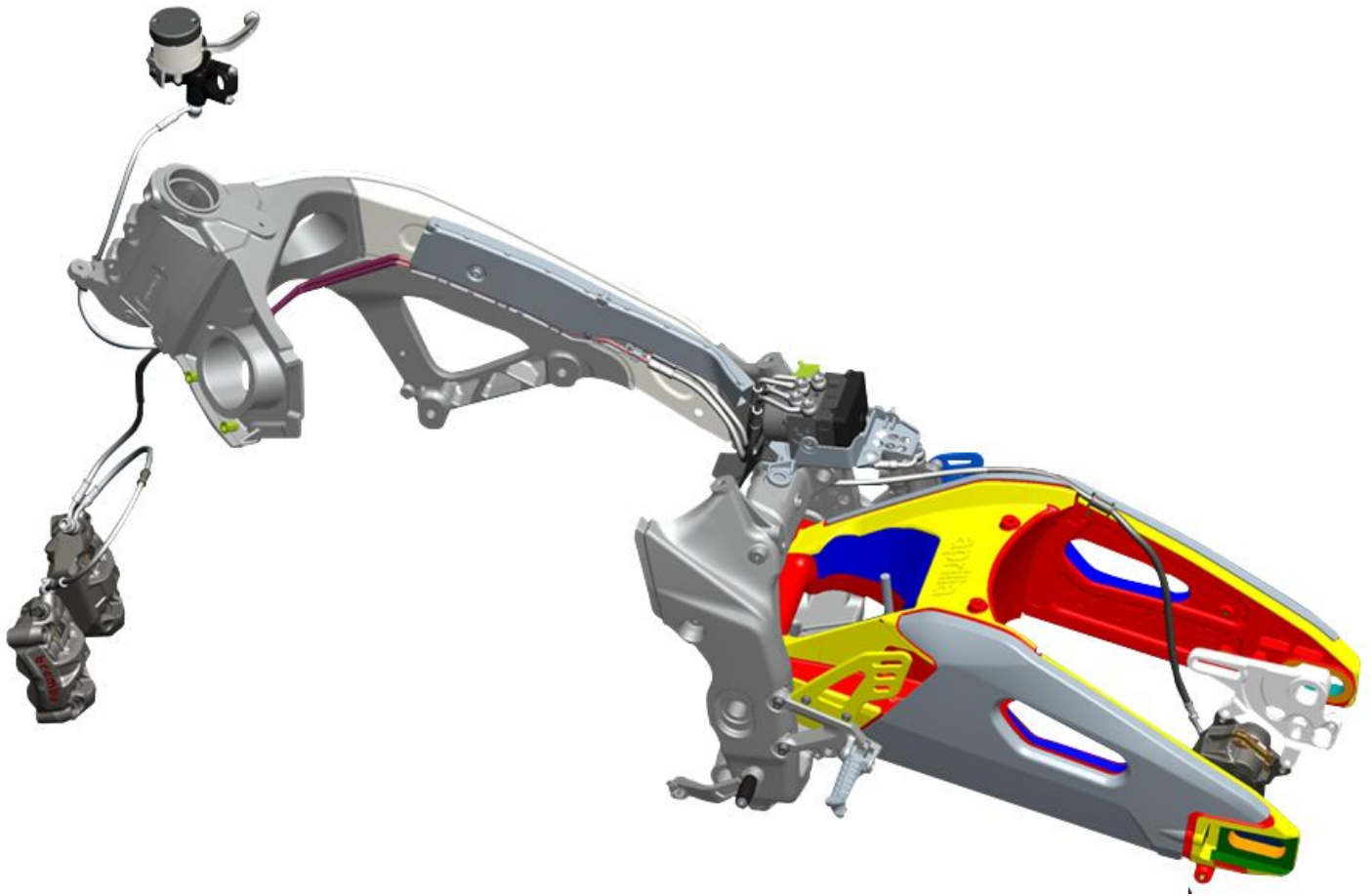

ABS functional diagram key

1. Front system circuit
2. Front brake pump
3. Front brake lever
4. Rear system circuit
5. Rear brake pump
6. Rear brake pedal control
7. ABS control unit
8. Rear brake calliper
9. Front calliper (2 callipers)
10. Front brake circuit intake solenoid valve (normally open)
11. Rear brake circuit intake solenoid valve (normally open)
12. Rear brake exhaust circuit solenoid valve (normally closed)
13. Rear/front brake circuit low pressure accumulator
14. Front brake exhaust circuit solenoid valve (normally closed)
15. DC electric motor
16. Double circuit hydraulic pump (ABS)

Intakes and supplies

1. Supply to the rear brake calliper.
2. Intake from the rear brake pump.
3. Intake from the front brake pump.
4. Supply to the front brake calliper.

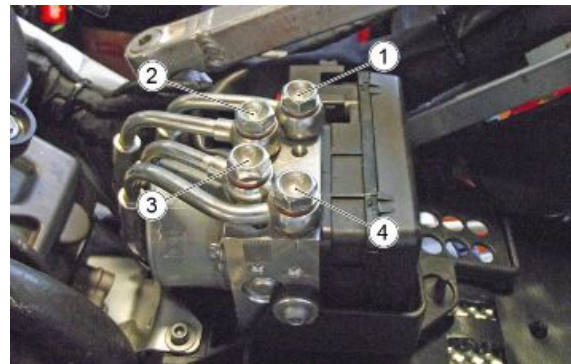

ABS OPERATION

General specifications:

The front circuit is similar to the rear circuit.

- The ABS inlet valve (10 - 11) is normally open and it is closed only when the system intervenes to avoid wheel locking.
- The exhaust valve (12 - 14) is normally closed and is only opened when the system intervenes to prevent locking.
- With the system in stand-by mode, the ABS processor controls the wheel speed instant by instant to assess any slippage of the wheels.
- When in standby, the system does not intervene at all when the rider brakes; the braking system is the same as the one without ABS.

Stages in ABS cycle (the following operations refer to the front circuit but are also applicable to the rear one):

A - Brake activation: the rider starts braking as he would usually do.

B - Pressure reduction: coincides with the recognition of the dangerous situation (wheel slippage exceeds the threshold): the system closes the inlet valve (10-11) and opens the outlet valve (12-13) temporarily.

At this stage the rider cannot increase the pressure on the callipers (8-9) and the system reduces the pressure on the callipers partially. Excess fluid temporarily fills the "reservoir" located inside the ABS modulator until the ABS pump (16) automatically activates to direct the fluid to the brake master (2 -5).

C - Pressure maintained: the pressure in the callipers (8-9) remains low until total recovery of speed / wheel grip.

The system restores the fluid taken from the calliper (8-9) in the section of the system between the brake pump (2-5) and the ABS inlet valve (10-11).

D - Pressure restoration: by opening the inlet valve (10-11) momentarily, the pressure of the callipers (8-9) is increased until maximum deceleration is reached. Then, the system gives the control over the braking back to the rider.

E - If the wheel does not reach complete grip, the system continues operating as before until complete grip is obtained or until the vehicle stops. An error can be detected if the duration of the pressure reduction phase exceeds the pre-set time limit.

ABS SYSTEM DESCRIPTION

The ABS system is a device to avoid wheels locking in case of emergency braking, increasing vehicle braking stability when compared to a traditional braking system.

The ABS system enhances control over the vehicle, taking into consideration never to exceed the physical limits of vehicle grip on the road. The rider is fully responsible for riding at a suitable speed based on weather and road conditions, always leaving an appropriate safety margin. Under no circumstances can the ABS system compensate for the rider's misjudgement or improper use of brakes. Sometimes when the brake is operated, the tyre locks with a consequent loss of grip, which makes it difficult to control the vehicle.

A position sensor (3) on the tone wheel (2), forming an integral unit with the vehicle wheel, "reads" the status of the vehicle wheel spotting any possible lock.

A control unit (1) signals this out and adjusts the pressure in the braking circuit accordingly.

CAUTION

WHEN THE ABS STARTS WORKING, A PULSING IS FELT ON THE BRAKE LEVER.



THE WHEEL ANTILOCK BRAKING SYSTEM DOES NOT PREVENT FALLS WHILE ON A BEND. AN EMERGENCY BRAKING WITH THE VEHICLE INCLINED, HANDLE BAR TURNED, ON UNEVEN OR SLIPPERY ROADS, OR WITH POOR GRIP CREATES LACK OF STABILITY DIFFICULT TO HANDLE. THEREFORE, RIDE CAREFULLY AND SENSIBLY AND ALWAYS BRAKE GRADUALLY. BRAKING WHILE TURNING A CORNER IS SUBJECT TO LAWS OF PHYSICS WHICH NOT EVEN ABS CAN ELIMINATE.



When sensors (3) detect a significant speed difference between the rear and the front wheels (for example, when rearing up on the back wheel), the ABS system could take this as a dangerous situation. In this case, 2 things may occur:

- the ABS system intervenes by releasing pressure from the calliper until the wheel turns again at the same speed of the other wheel; it is not possible to brake for an instant.
- if the speed difference lasts long, the system may detect an error and deactivates the ABS system.

As a consequence, the system works as any regular braking system.

Riding with an active ABS system

- During the vehicle start-up, after the instrument panel initial check, the ABS warning light stops flashing when the speed is under 5 km/h (3.1 mph).

If the ABS warning light remains on when the vehicle is running, it means that a fault has been detected and the ABS system has been automatically deactivated.

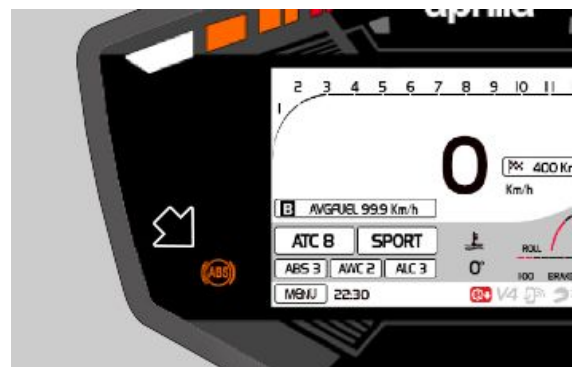

IN CASE OF FAILURE OR WITH ABS DISCONNECTED, THE VEHICLE OPERATES AS IF IT DID NOT HAVE THIS SYSTEM.

Activating/deactivating the ABS system

It is only possible to access the menu, and especially the section "**a-PRC CONFIGURATION**", which contains the item **ABS** when the vehicle is stationary and by using the MODE selector.



This function allows you to disable the ABS system that is normally active "On".

By briefly pressing in the middle or shifting the MODE selector switch to the right, the "ABS" function is highlighted in red. Shifting briefly upwards or downwards the function is deactivated "Off".

Briefly press the MODE selector to the left to return to the "aPRC configuration" menu.

aPRC CONFIGURATION	
ABS	On
Pit limiter	
Calibration	
V4-MP pairing	
LH switch	AWC
Exit	

CAUTION

IT IS DISABLED ONLY TEMPORARILY, WHEN THE KEY IS INSERTED THE SYSTEM IS ALWAYS ACTIVE. WHEN AN UNOFFICIAL MAP IS ACTIVE ("a-RACING" ICON LIT UP ON THE INSTRUMENT CLUSTER), THE ABS SYSTEM'S DEACTIVATION WILL ALSO BE PERMANENT THE NEXT TIME THE KEY IS TURNED ON.

NOTE

WHEN THE IGNITION KEY IS TURNED, IF THE SYSTEM IS FUNCTIONING CORRECTLY, THE ABS INDICATOR LAMP WILL FLASH (THE SYSTEM IS ACTIVATED AS SOON AS THE VEHICLE SPEED EXCEEDS 5 km/h - 3.1 mph)

Riding with the ABS system inactive

The warning light remains on in the steady state, the system has been deactivated.

REPLACING THE ABS CONTROL UNIT

- Before replacing the ABS control unit, mark the hoses so that they can be refit correctly on the new control unit.
- Remove the ABS support (1), the heat shield plate (2) and finally the ABS control unit.

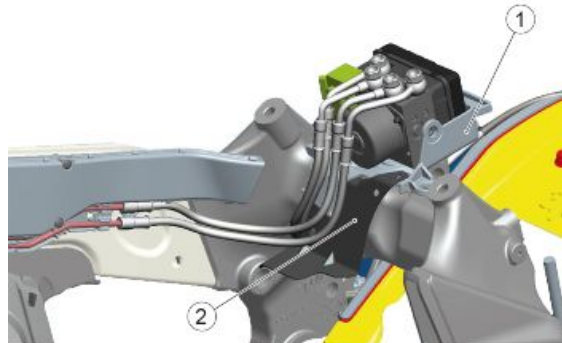

- In case of replacement or refitting of the front brake lines, take care that the steel ends are correctly lodged in the respective seats on the radiator support.



- Use clamps to secure any axial movements of the hoses.

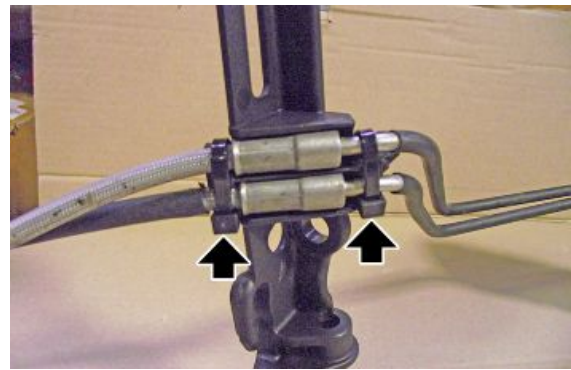

- Reposition the front brake steel pipes in the conduit, secure the pipes using clamps and observing the tolerances indicated in the figure.

Characteristic

Pipe axial clearance

0 - 0.10 mm (0 - 0.39 in)

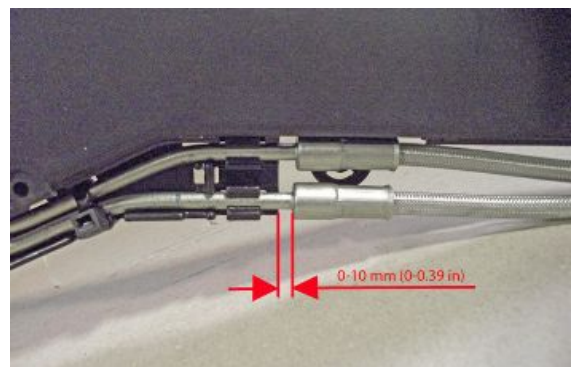

- Take care of hose position on the support.
 1. Goes to the pump.
 2. Goes to the caliper.



- After replacing hoses or the control unit the entire ABS system must be bled.

To bleed the ABS system optimally, it is advisable to use devices such as vacuum pumps or similar.

CAUTION



MORE OIL IS REQUIRED TO BLEED THE ABS SYSTEM THAN A CONVENTIONAL SYSTEM. FOR THIS REASON, CAREFULLY CHECK THE OIL LEVEL IN THE BRAKE TANK.

If there is a lever or brake pedal "sponginess" although the bleeding has been done, bleed the secondary circuit in the ABS control unit. To do this, carry out a road test by repeatedly activating the ABS positioning its threshold to level 3

After the bleeding has been done, delete any errors with the diagnostics instrument on the ABS control unit and on the 7SM one.

Before returning the vehicle, carry out a functional road test.

REPLACING/ACTIVATING NEW ABS CONTROL UNIT

In case of replacement of the ABS control unit, ensure that the new one has caps on all four hydraulic connections and then proceed as follows:

- Before disconnecting the electrical connections, switch the key "OFF".
- After hydraulic and electrical connection of the new ABS control unit, activation/recognition must be carried out.
- Switch the key "ON".
- Verify that the ABS indicator light flashes rapidly.
- Turn the key to "OFF" and then back to "ON".
- If activation is successful, the warning light should light up with a slow flash.
- In case of faults, the indicator light should be steady with the diagnostics instrument disconnected.
- Connect the diagnostics instrument and check if there are errors.

ABS PIPES ROUTING

TABLE A - ABS PIPES ROUTING

1. Small clamps



TABLE B - ABS PIPES ROUTING

1. Rear speed sensor cable.
2. Cable guide.
3. Cable grommet.
4. Cable grommet.

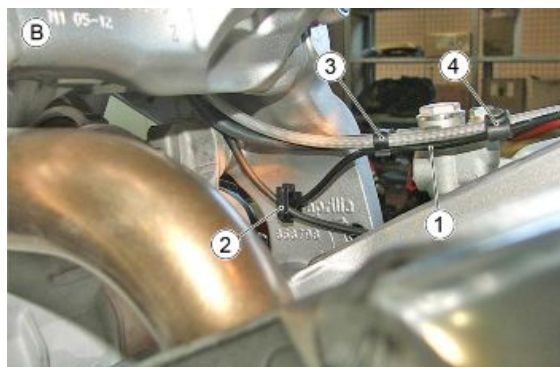
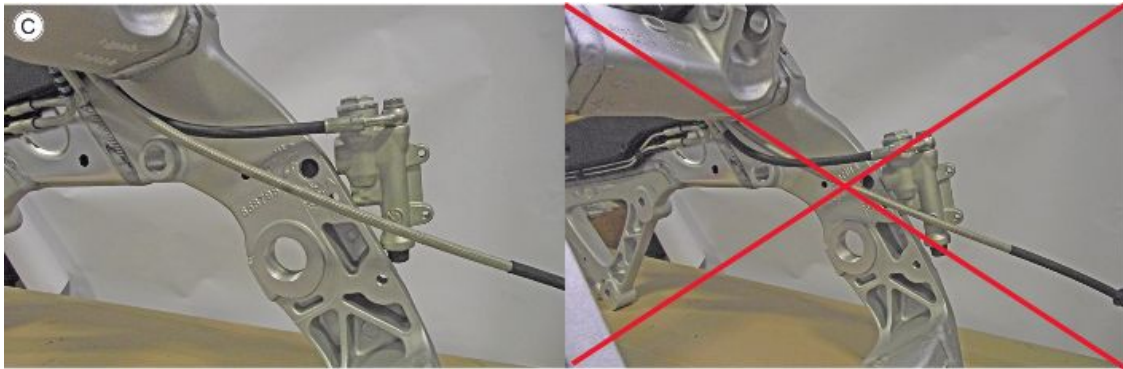

TABLE C - ABS PIPES ROUTING

The hydraulic pipes must necessarily pass as shown in the figure.

**TABLE D - ABS PIPES ROUTING**

1. Delivery rear calliper.
2. Input from the rear pump.
3. Delivery front calliper.
4. Input from the front pump.
5. Medium clamp.



Guide to diagnosis

PREMISE

Each time the key is ON, if, at least one current or stored* error is detected, the ABS warning light turns on permanently.

The ABS system is deactivated automatically

The system operates perfectly just as any other braking system without ABS

* The diagnosis requires exceeding the 5 km/h (3.1 mph).

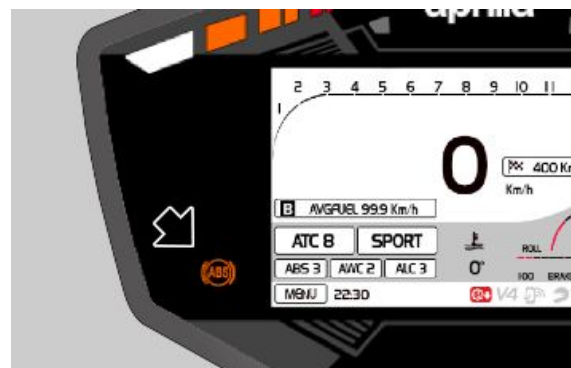

Each time the key is ON, if at least one current or stored* error of the ABS system is not detected:

- the abs warning light flashes.

When the 5 km/h (3.1 mph) are exceeded:

- if errors are not detected: the ABS warning light turns off
- if at least one malfunction is detected: the ABS warning light turns on permanently.

The ABS system is disabled!

The system operates perfectly just as any other braking system without ABS.

The detection of malfunctions may require more or less time according to the type of failure.

Error detection logic foresees that for the errors to be diagnosed one or more conditions must persist within a given time.

If during this given time one of the conditions is missing but then it comes back, the timer is reset and the system is no longer able to diagnose the error.

The ABS system continues to be inactive.

GUIDE TO ABS FAULT DIAGNOSIS

1. ABS LAMP ON

2. CONNECT THE DIAGNOSTIC TOOL

DOES THE DIAGNOSTIC TOOL COMMUNICATE? (NO, go to 3; YES, go to 4)

3. PERFORM THESE CHECKS:

- A. PIN 1 Ground connection
- B. +12V at PIN 18
- C. +12V live at PIN 4

4. ARE THERE ANY ERRORS? YES, go to point 5; NO, go to 6)

5. CHECK THE ERRORS TABLE

6. ABS WARNING LIGHT ACTIVATION

IS IT ACTIVATED?(YES, go to point 7; NO, go to point 8)

7. CONTACT TECHNICAL SERVICE

8. PERFORM THESE CHECKS:

- A. CAN line integrity from the ABS modulator (PIN 2, PIN 11) to the instrument panel (PIN 26, PIN 27).
- B. Check connectors - refer to the operations described in the chapter

If the above checks are OK, the causes can be:

- C. ABS Control unit malfunction
 - D. Instrument panel malfunction
-

Use of diagnostics instrument for ABS system

Abs screen pages

ECU INFO screen page

This screen shows general data regarding the control unit, for example software type, mapping, control unit programming date

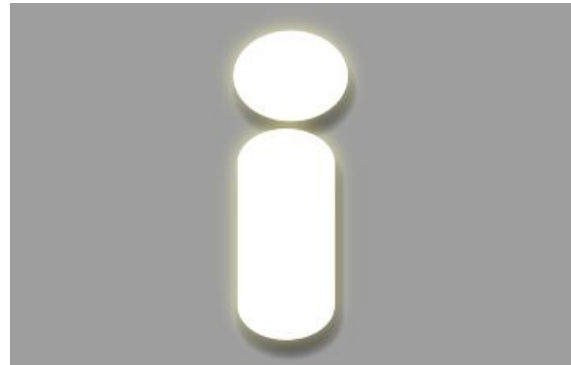

CONTROL UNIT DATA

P.A.D.S. characteristic.	Value/example	Units of measurement	Notes
Spare part code	CM281701	-	-
SW version	-	-	-
Vehicle manif. or encoding	-	-	-
Chassis or diagn. tool no.	-	-	-
Saved vehicle ID	-	-	-
Vehicle ID read by the ECU	-	-	-

PARAMETERS screen page

This screen shows the parameters measured by the several sensors (engine revs, engine temperature, etc.) or values set by the control unit (injection time, ignition advance, etc.)



PARAMETERS AND STATUSES

P.A.D.S. characteristic.	Value/example	Units of measurement	Notes
Speed of the front wheel	-	km/h	-
Speed of the rear wheel	-	km/h	-
Battery voltage	-	D	-
Front brake circuit pressure	-	bar	-
ABS	-	-	-

Quality test of the sensors

When turning the wheel or acting on the brake, a variation of parameters must be detected.

ACTIVATION screen page

On this screen, you can delete the errors from the memory of the controller and you can enable some systems controlled by the control unit.



ACTIVATIONS

P.A.D.S. characteristic.	Value/example	Units of measurement	Notes
ABS Warning Light			

ERRORS screen page

This display shows potential errors detected in the vehicle (ATT) or stored in the control unit (MEM) and it allows to check error clearing (STO).



ERRORS

Description	Code	Symptom
Front wheel speed sensor: electrical diagnosis	C1033	short circuit to positive / short circuit to negative / open circuit
Front wheel speed sensor: functional diagnosis	C1034	Signal not plausible
Rear wheel speed sensor: electrical diagnosis	C1031	short circuit to positive / short circuit to negative / open circuit
Rear wheel speed sensor: functional diagnosis	C1032	Signal not plausible
Comparison between the front and rear wheel speed	C1024	excessive difference
Internal error: fault at the front circuit input electric valve	C1054	fault at the front circuit input electric valve
Internal error: fault at the front circuit output electric valve	C1049	fault at the front circuit output electric valve
Internal error: fault at the rear circuit input electric valve	C1052	fault at the rear circuit input electric valve
Internal error: fault at the rear circuit output electric valve	C1048	fault at the rear circuit output electric valve
Internal error: fault at the recirculation pump	C1015	fault at the recirculation pump
Internal error: fault at the electric valve relay	C1014	fault at the electric valve relay
Internal error: fault at the control unit	C1021	fault at the control unit
Low power supply voltage	C1058	low voltage
High power supply voltage	C1059	high voltage
Encoding error	C1089	-
CAN error: controller error	U2921	controller error
CAN error: line failure (busoff)	U2922	line failure (busoff)
CAN error: failed reception at the instrument panel	U2924	failed reception at the instrument panel
CAN error: failed reception at the injection control unit	U2925	failed reception at the injection control unit

Description	Code	Symptom
+ button (connect to the injection control unit diagnosis)	U2926	connect to the 7SM control unit diagnosis
- button (connect to the injection control unit diagnosis)	U2927	connect to the 7SM control unit diagnosis
Internal error: fault at the pressure sensor	C1331	fault at the pressure sensor
Internal error: fault at the pressure sensor (offset)	C1332	fault at the pressure sensor (offset)
Internal error: fault at the pressure sensor (power supply)	C1333	fault at the pressure sensor (power supply)
Internal error: fault at the pressure sensor (plausibility)	C1077	fault at the pressure sensor (plausibility)
Network under-voltage	U2930	low voltage
Network overvoltage	U2931	high voltage
Error/timeout CAN message	U2932	-
Error/DLC/counter CAN message	U2933	-
Error/timeout CAN message	U2934	-
CAN signal error message	U2935	-
MM5 CAN frame error	U2928	-
MM5 CAN signal	U2929	-
MM5 incorrect mounting	U1092	-
MM5 model monitoring	U1094	-

PADS report mode

In the following are described the procedure to be performed through the diagnostic tool in order to generate an errors report:

- When started the program, select the brand.



- Select the vehicle and the component.

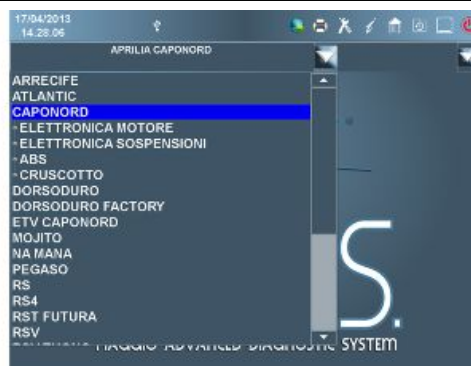

- Select Self-diagnosis.



- Go to the page Error codes.

- Select an error and show the Ambient parameter error(where provided).

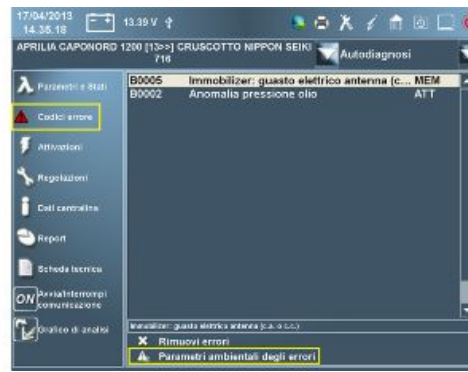

- Repeat the operation by selecting each error and showing the corresponding Ambient parameter error (where provided).

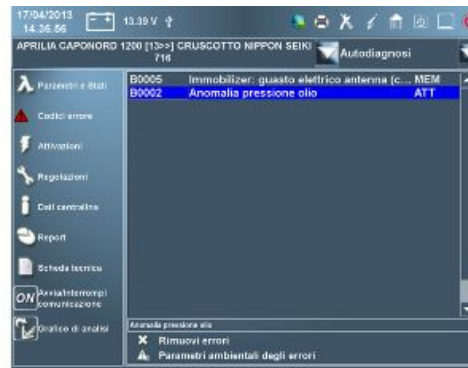

- Go to the page Report and then on Print and select the virtual PDF printer.

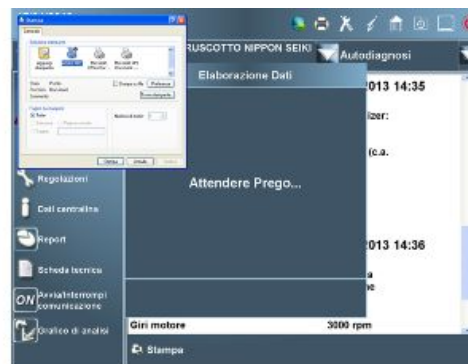

- If there is no PDF printer, there are several free programs, ask the information systems to install it.
- Name the file with a name that contains the main information of the vehicle and the analysed component e.g. CN1200-Chassis0465-Instrument panel.

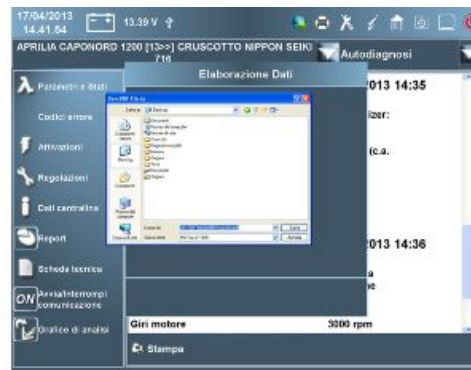

SETTINGS screen page

This screen is used to adjust some control unit parameters.



ADJUSTMENTS

P.A.D.S. characteristic.	Value/example	Units of measurement	Notes
Encoding reset	-	-	Resets the vehicle code and obtains it automatically from the CAN line at the next key ON

Diagnosis

SPEED SENSORS ERRORS

C1024 Comparison between the front and rear wheel

Electrical diagnosis:

Excessive difference.

Error cause

- Incorrect wheel or tone wheel dimensions.

Troubleshooting

- Check the type and dimensions of the installed tyres.
- Check the type and dimensions of the installed tone wheels.

C1031 Rear wheel speed sensor

Electrical diagnosis:

Open circuit, short circuit to negative or short circuit to positive.

Error cause:

- Open circuit: circuit interruption detected.
- Short-circuit to negative: null voltage detected on PIN 14 of the ABS control unit.
- Short-circuit to positive: excessive voltage detected on PIN 14 of the ABS control unit.

Troubleshooting:

Open circuit:

- Check the connectors on the component and on the ABS control unit.
- Check the integrity and continuity of the wiring harnesses:
 - between PIN 14 of the ABS control unit and PIN 1 of the sensor (yellow cable)
 - between PIN 13 of the ABS control unit and PIN 2 of the sensor (yellow/brown cable)

Short-circuit to negative:

- Disconnect the sensor connector.
- Check the ground insulation of the two PINS.
- If there is no insulation, restore the wiring harness or replace the sensor.

Short-circuit to positive:

- Disconnect the sensor connector.
- Check the battery supply insulation of the two PINS.
- If there is no insulation, restore the wiring harness or replace the sensor.

C1032 Rear wheel speed sensor**Functional diagnosis:**

Signal not plausible.

Error cause:

- Possible tone wheel fault due to deformations or dirt.

Troubleshooting:

- Check that the tone wheel is not damaged and is clean.
- Check that the number of teeth on the tone wheel is correct.
- Check that the tone wheel and the sensor are correctly positioned;
- Check that the tyre is the correct size.
- If all these checks are positive, replace the sensor.

C1033 Front wheel speed sensor**Electrical diagnosis:**

Open circuit, short circuit to negative or short circuit to positive.

Error cause:

- Open circuit: circuit interruption detected.
- Short-circuit to negative: null voltage detected on PIN 3 of the ABS control unit.
- Short-circuit to positive: excessive voltage detected on PIN 3 of the ABS control unit.

Troubleshooting:

Open circuit:

- Check the connectors on the component and on the ABS control unit.
- Check the integrity and continuity of the wiring harnesses:
 - between PIN 3 of the ABS control unit and PIN 1 of the sensor (white cable)
 - between PIN 12 of the ABS control unit and PIN 2 of the sensor (white/brown cable)

Short-circuit to negative:

- Disconnect the sensor connector.
- Check the ground insulation of the two PINS.
- If there is no insulation, restore the wiring harness or replace the sensor.

Short-circuit to positive:

- Disconnect the sensor connector.
- Check the battery supply insulation of the two PINS.
- If there is no insulation, restore the wiring harness or replace the sensor.

C1034 Front wheel speed sensor

Functional diagnosis:

Signal not plausible.

Error cause:

- Possible tone wheel fault due to deformations or dirt.

Troubleshooting:

- Check that the tone wheel is not damaged and is clean.
- Check that the number of teeth on the tone wheel is correct
- Check that the tone wheel and the sensor are correctly positioned;
- Check that the tyre is the correct size.
- If all these checks are positive, replace the sensor.

VOLTAGE ERRORS

C1058 Low power supply voltage

C1059 High power supply voltage

Error cause:

Power supply voltage below minimum threshold or above maximum threshold detected on PIN 4 or on PIN 18 of the ABS control unit.

This error is indicated by lighting up in a fixed manner the ABS warning light.

Troubleshooting:

- Check that the voltage regulator is working correctly.
- Check the battery.

NOTE

THIS ERROR DISABLES THE ABS SYSTEM.

CONFIGURATION ERRORS

C1089 Configuration error

Error cause:

The configuration stored in the ABS control unit does not correspond to the configuration in the vehicle it is installed on.

Troubleshooting:

Check the control unit mapping and reset the vehicle configuration.

NOTE

THIS ERROR DISABLES THE ABS SYSTEM.

CAN LINE ERRORS**U2921 Controller error****U2922 Line failure (busoff)****Error cause:**

Communication problem on CAN line: possible contact.

Troubleshooting:

Check the integrity and continuity of the wiring harness:

- between ABS control unit PIN 2, instrument panel PIN 33 and injection control unit PIN 80 (Orange cable)
- between ABS control unit PIN 11, instrument panel PIN 32 and injection control unit PIN 66 (White/Black cable)

U2924 Failed reception at the instrument panel**Error cause:**

Communication problem with the instrument panel: possible CAN line contact.

Troubleshooting:

Check continuity of wiring harness:

- between PIN 2 of the ABS control unit and PIN 33 of the instrument panel (Orange cable)
- between PIN 11 of the ABS control unit and PIN 32 of the instrument panel (White/Black cable)

U2925 Failed reception from injection control unit**Error cause:**

Communication problem with the injection control unit: possible CAN line contact.

Troubleshooting:

Check continuity of wiring harness:

- between PIN 2 of the ABS control unit and PIN 80 of the injection control unit (Orange cable)
- between PIN 11 of the ABS control unit and PIN 66 of the injection control unit (White/Black cable)

+/- BUTTON ERRORS

Key:

- A. Button "+" open
- B. Button "+" closed
- C. Button "-" open
- D. Button "-" closed

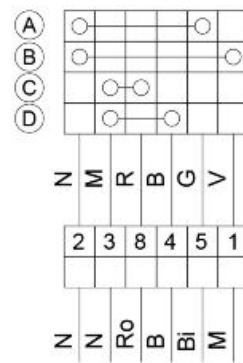

U2926 + button

U2927 - button

Error cause

Switch malfunction.

Troubleshooting

- Connect to the injection control unit diagnosis
- Check according to the indication in the figure whether there is or not continuity between the contact of the switches and in the various opening/closing states:
 - with the "+" button open, the "-" button must be closed
 - with the "+" button closed, the "-" button must be open

Modulator

- Disconnect the ABS connector.



- Disconnect and remove the brake pipes inserts from the ABS control unit.
- Undo the fixing screw of the ABS control unit



- Disconnect the ABS control unit from its rear inserts.
- Remove the ABS control unit

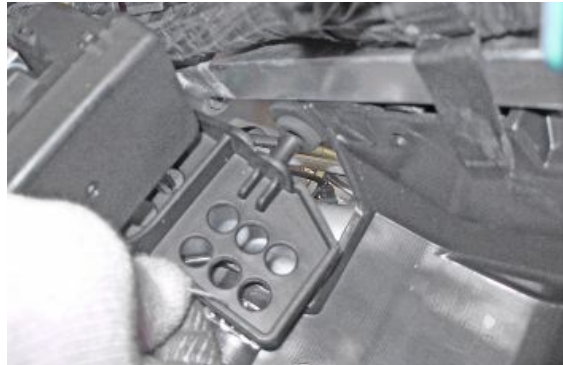

INSERTION PROCEDURE OF ABS CONTROL UNIT CONNECTOR

- Check the initial position of the lever that couples the connector.



- When the connector is fully inserted, the distance between the connector and the ABS control unit must be 7.5 mm (0.29 in).

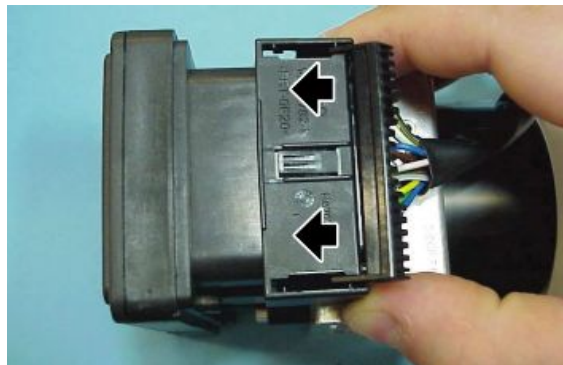

- If the initial position of the connector and the driving lever is not that shown in fig. 1, the connector will not be properly coupled and the distance measured will be greater (12 mm approx. (0.47 in)). In this case repeat the operation as described in the two previous points.

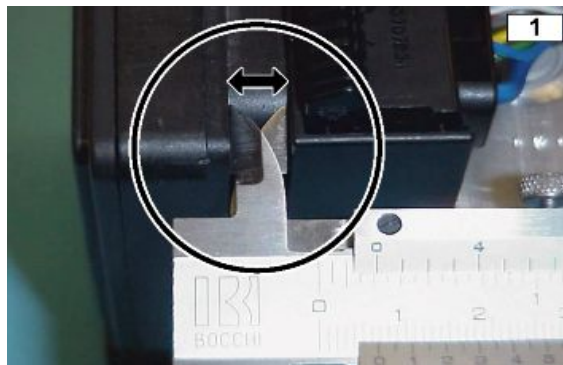

IT IS ADVISABLE TO CREATE A TEMPLATE TO CHECK THE CORRECT CONNECTOR INSERTION.

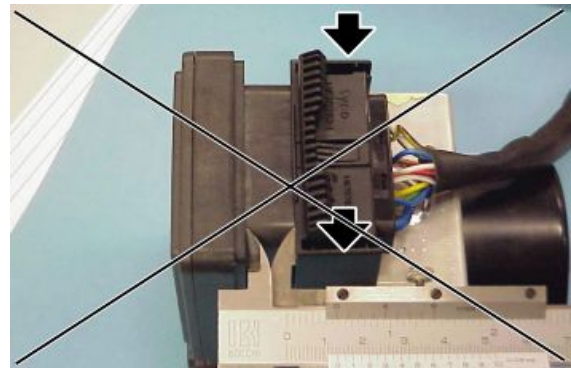

- Fit the protection casing.

Component maintenance

The vehicle is fitted with a two-channel ABS system, i.e. it works on both the front and the rear wheel.

Check periodically and each time the wheels are refitted, the tone wheel (2) or the sensor (1) replaced, that the wheel distance is constant at each 360°. Use a thickness gauge to check the distance between sensor (1) and tone wheel (2) at three points at a 120° span. The values should be between:

0.3 - 2.00 mm (0.012 - 0.079 in) for the front one;

0.3 - 2.00 mm (0.012 - 0.079 in) for the rear one;

CAUTION

IF A VALUE BEYOND THE TOLERANCE RANGE IS MEASURED, REPLACE THE SENSOR (1) AND/OR THE TONE WHEEL (2) AND REPEAT THE CHECKS; MAKE SURE THAT THE VALUES ARE WITHIN THE TOLERANCE LIMITS.

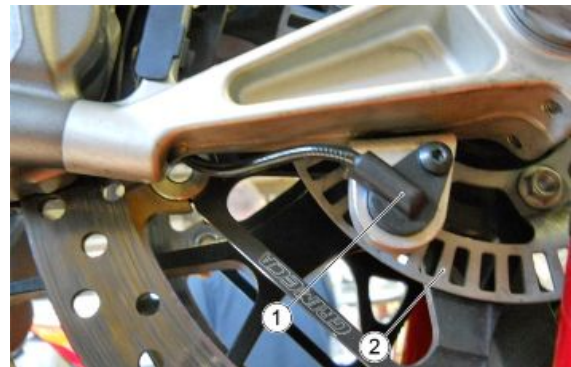

ZONE WHEELS (2) CLEANING

It is important to check that all the tone wheels (2) are always clean. Otherwise, gently remove any possible dirt deposits with a cloth or metal brush. Avoid using solvents, abrasives and air or water jets directly on the tone wheel (2).

ZONE WHEEL SENSOR REPLACEMENT

Disconnect the tone wheel sensor connector (1) from the main wire. Unscrew and remove the screw and remove the tone wheel sensor (1).

CAUTION

BEFORE REFITTING, MAKE SURE THAT THE FAYING SURFACES BETWEEN THE SENSOR (1) AND THE SEAT ITSELF DO NOT SHOW SIGNS OF DAMAGE AND ARE COMPLETELY CLEAN. ALWAYS CHECK THE DISTANCE BETWEEN THE SENSOR (1) AND THE TONE WHEEL (2).

Rear brake calliper

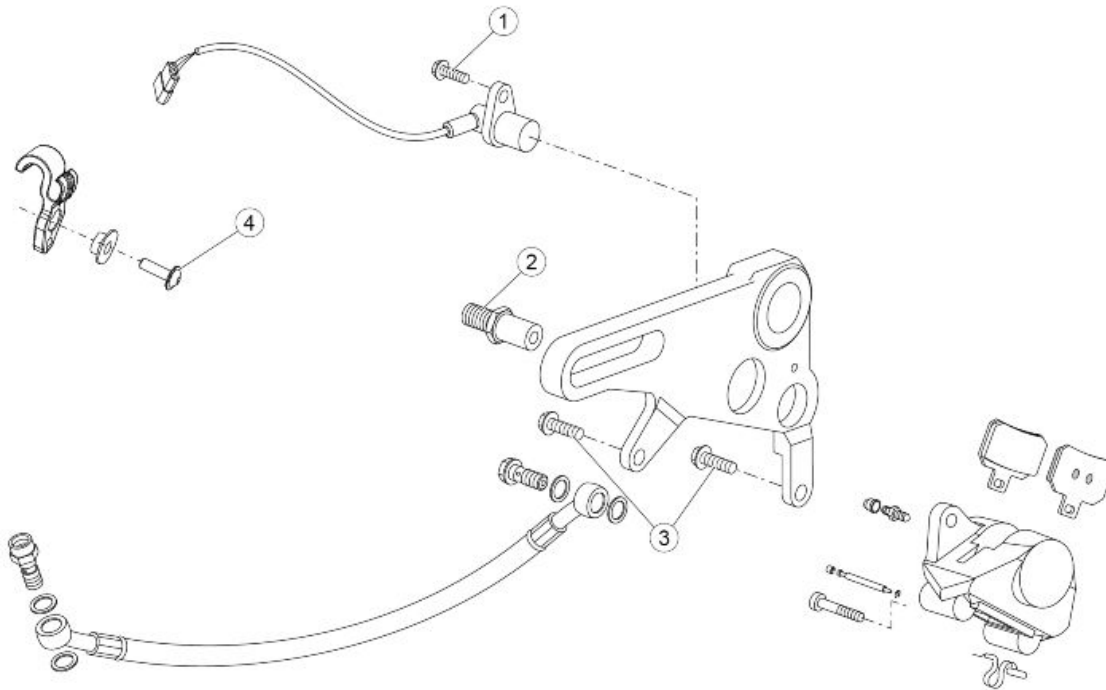

REAR BRAKE CALLIPER

Pos.	Description	Type	Quantity	Torque	Notes
1	ABS sensor fixing screw	M6	1	6 Nm (4.43 lb ft)	-
2	Rear brake calliper support plate retaining pin	M12	1	50 Nm (36.88 lb ft)	Loct. 243
3	Rear brake calliper fastening screw	M5	2	25 Nm (18.44 lb ft)	-
4	Brake pipe bracket fastening screw	M5	1	4 Nm (2.95 lb ft)	-
-	Screw fastening brake pipe clamp	M5	2	4 Nm (2.95 lb ft)	-

Front brake calliper

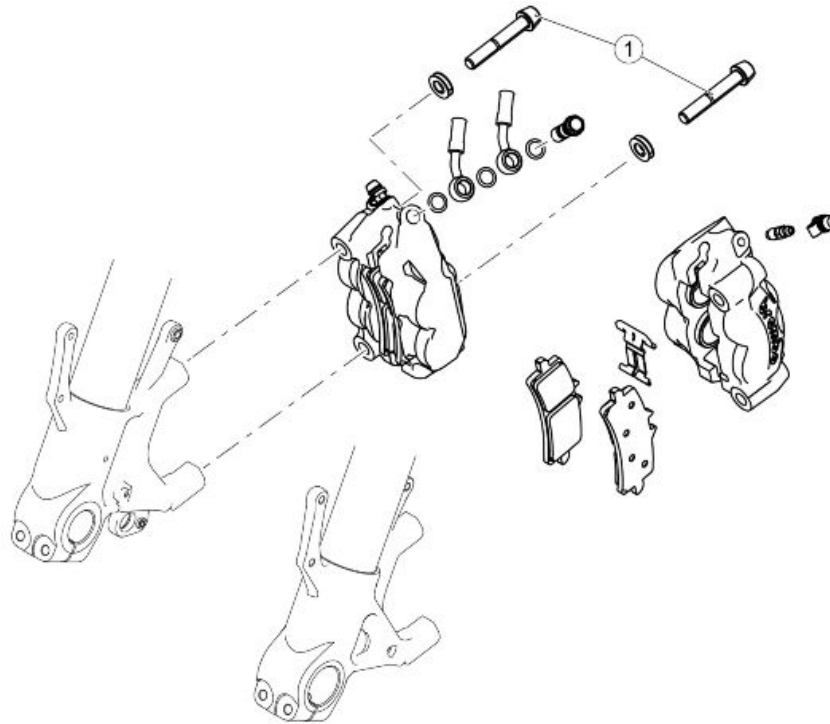

FRONT BRAKE CALLIPER

Pos.	Description	Type	Quantity	Torque	Notes
1	Front brake calliper fastening screws	M10x1.25	2 + 2	50 Nm (36.88 lb ft)	-

Rear brake disc

Removal

- Remove the rear wheel.

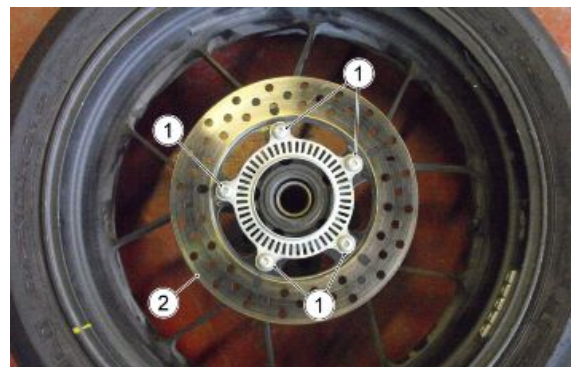

- Unscrew and remove the five brake disc screws (1).
- Remove the brake disc (2).



DURING REFITTING, APPLY LOCTITE 243 ON THE THREAD OF THE BRAKE DISC SCREWS (1).

CAUTION

DURING REFITTING, SCREW ALL THE SCREWS (1) MANUALLY AND TIGHTEN THEM OPERATING DIAGONALLY FOLLOWING THIS SEQUENCE: A-B-C-D-E.

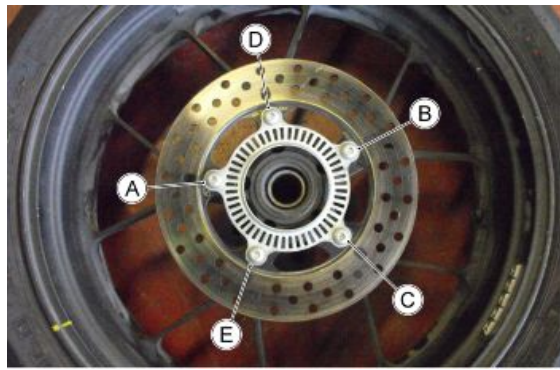

See also

[Removing the rear wheel](#)

Disc Inspection

The operations must be carried out with the brake disc fitted on the wheel.

- Check the disc for wear by measuring the minimum thickness with a micrometer in different points.
- If the minimum thickness, even in a single point of the disc, is less than the minimum value, replace the disc.

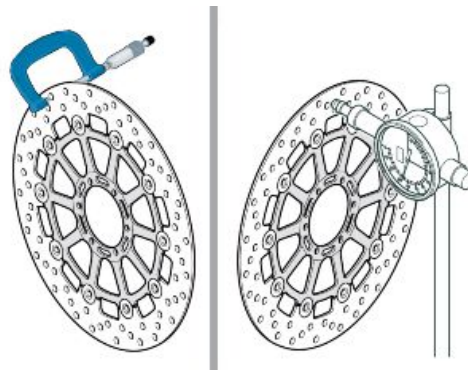

Disc thickness minimum value: 4.5 mm (0.18 in)

- Using a dial gauge, check that the maximum oscillation of the disc does not exceed the tolerance; otherwise, replace it.

Disc oscillation tolerance: 0.1 mm (0.0039 in)

Front brake disc

Removal

- Remove the front wheel

The following operations refers to a single disc but apply to both.

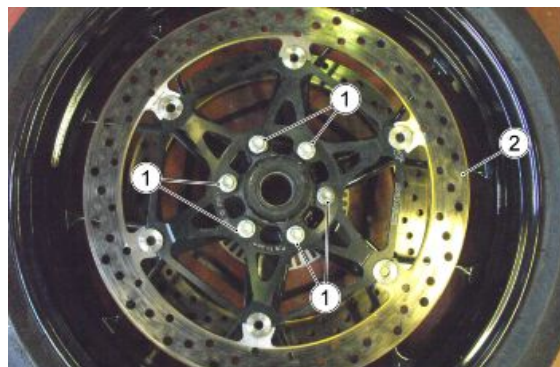

- Unscrew and remove the six brake disc screws (1).
- Remove the brake disc (2).



UPON REFITTING, APPLY LOCTITE 243 ON THE THREAD OF THE BRAKE DISC SCREWS (1).

CAUTION

UPON REFITTING, SCREW ALL THE SCREWS (1) MANUALLY AND TIGHTEN THEM OPERATING DIAGONALLY FOLLOWING THIS SEQUENCE: A-B-C-D-E-F.

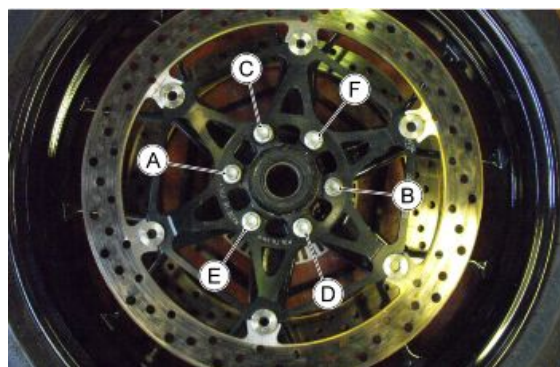

See also

[Removing the front wheel](#)

Disc Inspection

- The following operations must be carried out with the brake discs fitted on the wheel; they refer to a single disc, but are valid for both.
- Check the disc for wear by measuring the minimum thickness with a micrometer in different points. If the minimum thickness, even in a single point of the disc, is less than the minimum value, replace the disc.

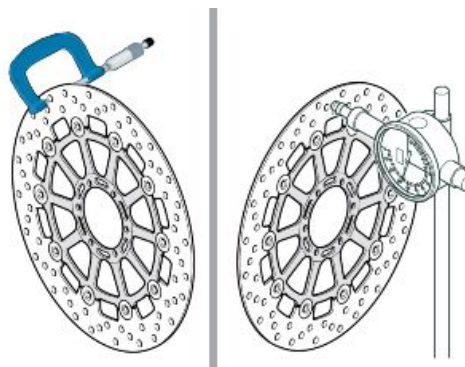

Disc thickness minimum value: 4 mm (0.16 in)

- Using a dial gauge, check that the maximum oscillation of the disc does not

exceed the tolerance; otherwise, replace it.

Disc oscillation tolerance: 0.15 mm (0.0059 in)

Front brake pads

Removal



THIS VEHICLE IS FITTED WITH A DOUBLE DISC FRONT BRAKING SYSTEM (RIGHT AND LEFT SIDE).

ALWAYS REPLACE ALL THE PADS FROM BOTH FRONT BRAKE CALLIPERS.

REPLACING THE PADS OF ONLY ONE FRONT CALLIPER MAY JEOPARDISE THE VEHICLE STABILITY AND SAFETY, POSING SERIOUS DANGER FOR PEOPLE, OBJECTS AND THE VEHICLE ITSELF.

CAUTION

THE FOLLOWING OPERATIONS REFER TO A SINGLE CALLIPER, BUT APPLY TO BOTH.

- Unscrew and remove the two screws (1).
- Slide off the disc from the front brake calliper.

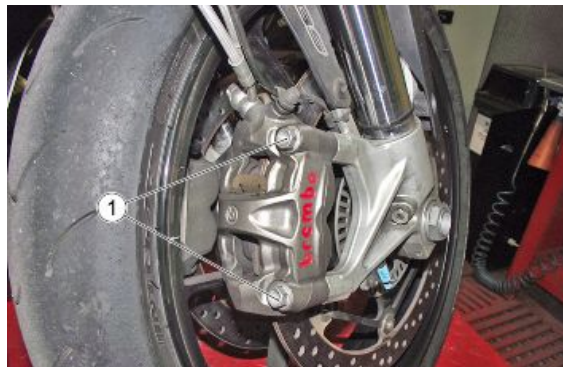

- Separate the brake calliper pistons.
- Remove the pads from the brake calliper.
- Retrieve the clip.



AFTER REMOVING THE PADS, DO NOT OPERATE THE BRAKE CONTROL LEVER OR THE CALLIPER PLUNGERS COULD GO OUT OF THEIR SEATS RESULTING IN BRAKE FLUID LEAKAGE.

Installing

- An arrow is stamped on the brake calliper and on the clip, which must always point in the direction of rotation of the front wheel.
- Fit the clip in the brake calliper.

- Fit the two new pads in the correct position.



ALWAYS REPLACE THE FOUR PADS AND MAKE SURE THEY ARE CORRECTLY POSITIONED INSIDE THE CALIPER.



- Fit the front brake calliper on the disc.
- Hand-tighten the two screws (1) fully.
- Pull the front brake lever to seat the brake calliper correctly.
- Tighten the two screws (1).
- Check the front brake fluid level.

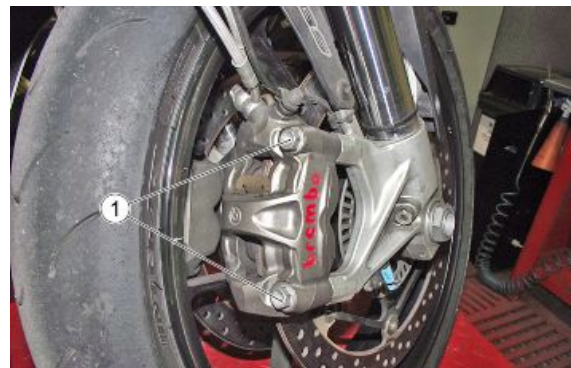

Rear brake pads

Removal

- Rest the vehicle on its stand.
- Remove the rear brake calliper.

CAUTION

DO NOT ACTUATE ON THE REAR BRAKE LEVER AFTER REMOVING THE WHEEL, OTHERWISE THE CALLIPER PLUNGER COULD GO OUT OF ITS SEAT, RESULTING IN BRAKE FLUID LEAKAGE.

- Remove the snap ring (1).



BEFORE REMOVING THE PIN (2), CHECK THAT THE SAFETY SPRING (3) IS CORRECTLY POSITIONED; WHEN REFITTED, IT MUST BE POSITIONED IN THE SAME WAY.

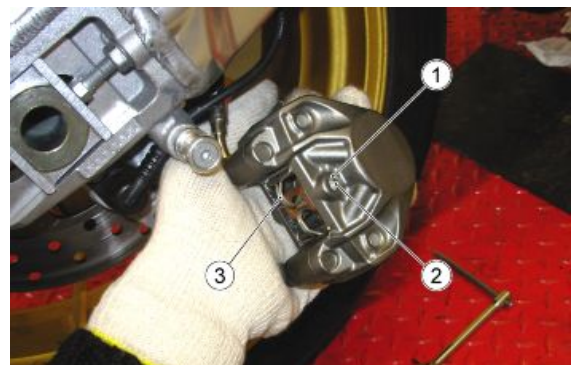

- Remove the pin (2) and retrieve the safety spring (3).
- Extract the two pads (4) and retrieve the noise damping plates.
- If worn, replace the vibration damping plates.

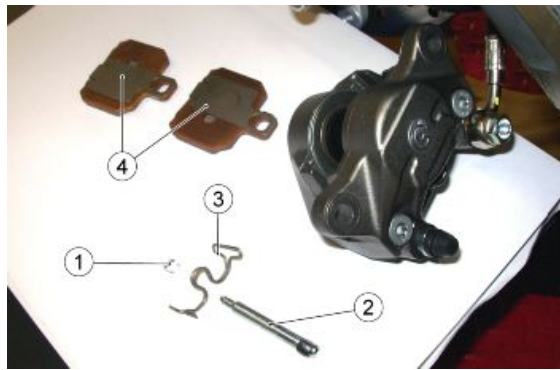

AFTER REMOVING THE PADS, DO NOT OPERATE THE BRAKE CONTROL LEVER OR THE CALLIPER PLUNGERS COULD GO OUT OF THEIR SEATS RESULTING IN BRAKE FLUID LEAKAGE.

Installing

- Insert two new pads and the vibration-damping plates, placing them so that the holes are aligned with the calliper holes.



UPON REFITTING, MAKE SURE THE ARROWS ON THE VIBRATION-DAMPING PLATES FACE THE DIRECTION OF ROTATION OF THE WHEEL.

CAUTION



ALWAYS REPLACE BOTH PADS AND MAKE SURE THEY ARE CORRECTLY POSITIONED INSIDE THE CALLIPER.



- Place the safety spring (3).
- Hold the centre of the safety spring (3) depressed and insert the pin (2) so it passes above the spring.
- Fit the retainer ring (1).
- Check the brake fluid.

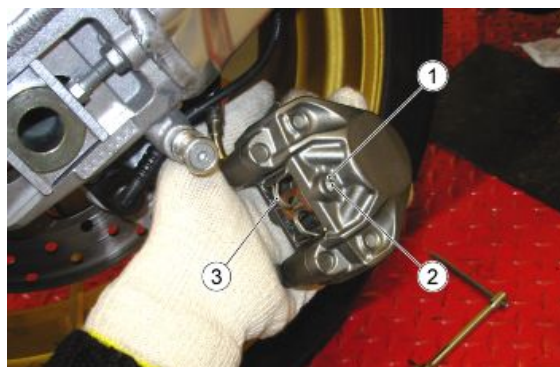

Bleeding the braking system

Front

Any air trapped in the hydraulic circuit acts as a cushion, absorbing much of the pressure applied by the brake pump and minimising the braking power of the calliper.

The presence of air is signalled by the "sponginess" of the brake control and by poor braking efficiency.

CAUTION

IN VIEW OF THE DANGER THIS POSES FOR VEHICLE AND RIDER, THE HYDRAULIC CIRCUIT MUST BE BLED AFTER REFITTING THE BRAKES AND RESTORING THE BRAKING SYSTEM TO ITS NORMAL OPERATING CONDITIONS.

NOTE

THE FOLLOWING OPERATIONS REFER TO ONE FRONT BRAKE CALLIPER ONLY, BUT ARE VALID FOR BOTH. THE VEHICLE MUST BE ON LEVEL GROUND TO BE PURGED. WHILE PURGING THE HYDRAULIC SYSTEM, FILL THE RESERVOIR WITH THE NECESSARY QUANTITY OF BRAKE FLUID. CHECK THAT, DURING THE OPERATION, THERE IS ALWAYS BRAKE FLUID IN THE RESERVOIR.

La procedura di spurgo può essere eseguita in modo tradizionale o con l'uso di attrezzi specifici quali pompe a vuoto o simili. E' importante però procedere spurgando l'impianto nell'ordine che segue:

- Pompa freno.
- Pinza destra.
- Pinza sinistra.
- Pompa freno ("rifinitura").

Sotto è riportata la procedura di spurgo "tradizionale".

CAUTION



IN CASO DI SOSTITUZIONE DEL LIQUIDO FRENI, PROCEDERE COME PER UN IMPIANTO TRADIZIONALE SENZA ABS. RICORDARSI PERO' CHE UN COMPLETO RICAMBIO DEL LIQUIDO FRENI RICHIEDE UNA QUANTITA' MAGGIORE RISPETTO AD UN IMPIANTO TRADIZIONALE. PER LA POMPA FRENO ANTERIORE SIAMO NELL'ORDINE DI CIRCA TRE SERBATOI MENTRE, PER IL POSTERIORE SIAMO NELL'ORDINE DI CIRCA DUE SERBATOI.

- Remove the rubber protection cover from the bleed valve.
- Insert the transparent plastic pipe in the front brake calliper bleed valve and slide the other end of this pipe in a container to collect the fluid.
- Remove the front brake fluid reservoir cap.



- Operate the brake lever and then open the bleed valve on the calliper 1/4 of a turn to let the air out.
- Close the bleed again before reaching the lever end of the stroke and repeat the operation until there is no air.
- Repeat the procedure for both callipers.

- Screw the bleeding valve and remove the pipe.
- Top-up the reservoir until the correct brake fluid level is obtained.
- Refit and block the front brake oil reservoir cap.
- Refit the rubber protection cover.

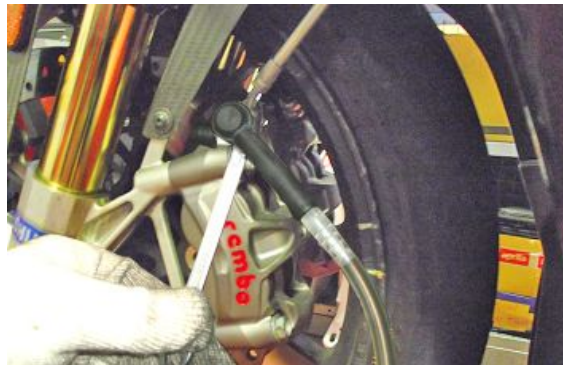

Rear

Any air trapped in the hydraulic circuit acts as a cushion, absorbing much of the pressure applied by the brake pump and minimising the braking power of the calliper.

The presence of air is signalled by the "sponginess" of the brake control and by poor braking efficiency.

CAUTION

IN VIEW OF THE DANGER THIS POSES FOR VEHICLE AND RIDER, THE HYDRAULIC CIRCUIT MUST BE BLED AFTER REFITTING THE BRAKES AND RESTORING THE BRAKING SYSTEM TO ITS NORMAL OPERATING CONDITIONS.

NOTE

THE VEHICLE MUST BE ON LEVEL GROUND TO BE BLED. WHILE BLEEDING THE HYDRAULIC SYSTEM, FILL THE RESERVOIR WITH THE NECESSARY QUANTITY OF BRAKE FLUID. CHECK THAT, DURING THE OPERATION, THERE IS ALWAYS BRAKE FLUID IN THE RESERVOIR.

- Remove the rubber protection cover from the bleed valve.
- Insert the transparent plastic pipe in the rear brake calliper bleed valve and insert the other end of this pipe into a container to collect the fluid.
- Remove the rear brake fluid reservoir cap.

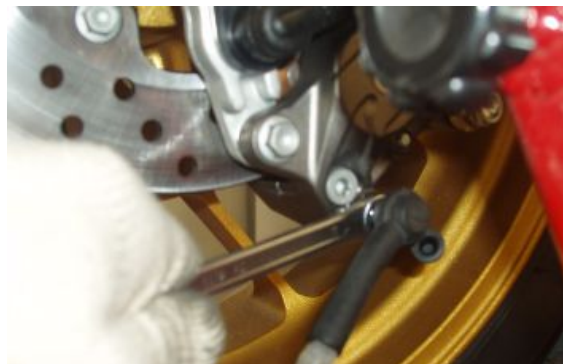

- Operate the brake lever and then open the bleed valve on the calliper 1/4 of a turn to let the air out.
- Close the bleed again before reaching the lever end of the stroke and repeat the operation until there is no air.
- Screw the bleeding valve and remove the pipe.
- Top-up the reservoir until the correct brake fluid level is obtained.
- Refit and lock the rear brake oil reservoir cap.
- Refit the rubber protection cover.

Front brake pump

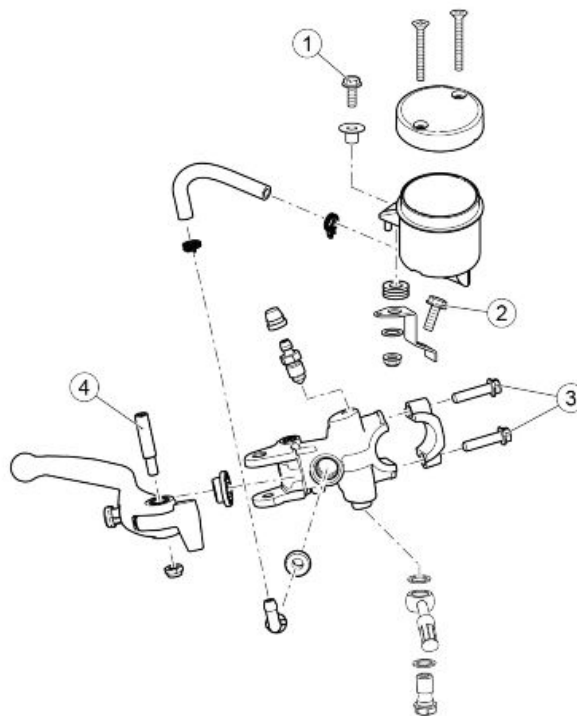

FRONT BRAKE PUMP

pos.	Description	Type	Quantity	Torque	Notes
1	Screw fastening front brake fluid reservoir to bracket	M6	1	7 Nm (5.16 lb ft)	-
2	Screw fastening brake fluid reservoir mounting bracket to handlebar	M6	1	7 Nm (5.16 lb ft)	-
3	Front brake pump U bolt clamp	M6	2	10 Nm (7.38 lb ft)	-
4	Front brake lever pin fixing screw	M6	1	10 Nm (7.38 lb ft)	-
-	Screw fastening brake pipe grommet to the lower yoke	M5	1	8 Nm (5.90 lb ft)	-

Rear brake pump

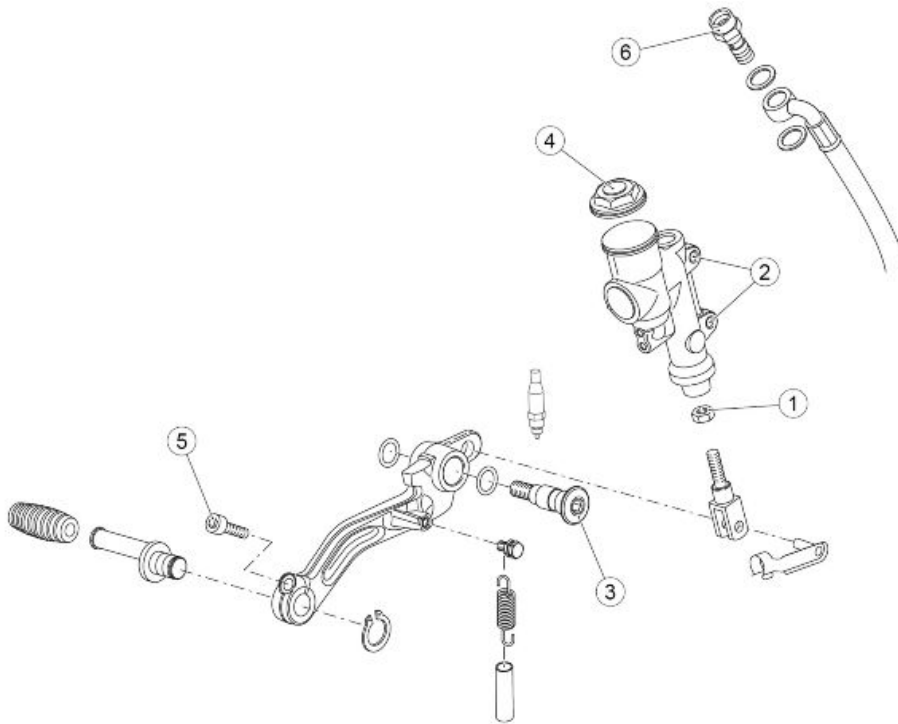
**REAR BRAKE MASTER CYLINDER**

Pos.	Description	Type	Quantity	Torque	Notes
1	Rear brake rod lock nut	M6	1	12 Nm (8.85 lb ft)	-
2	Rear brake pump retaining screws	M6	2	8 Nm (5.90 lb ft)	Loctite 243
3	Rear brake lever fixing pin	M8	1	25 Nm (18.44 lb ft)	Loctite 243
4	Tank filler cap	-	1	17-23 Nm (12.54-16.96 lb ft)	-
5	Brake lever ferrule retaining screw	M6	1	8 Nm (5.90 lb ft)	-
6	Special oil pipe coupling retaining screw	-	1	23-26 Nm (16.96-19.18 lb ft)	-

INDEX OF TOPICS

COOLING SYSTEM

COOL SYS

Circuit diagram

SYSTEM TYPE

Self bleeding cooling circuit with aspirating centrifugal pump (1), three-way thermostat valve (2), cooling radiator (3) with electric fans (4) and expansion tank (5).

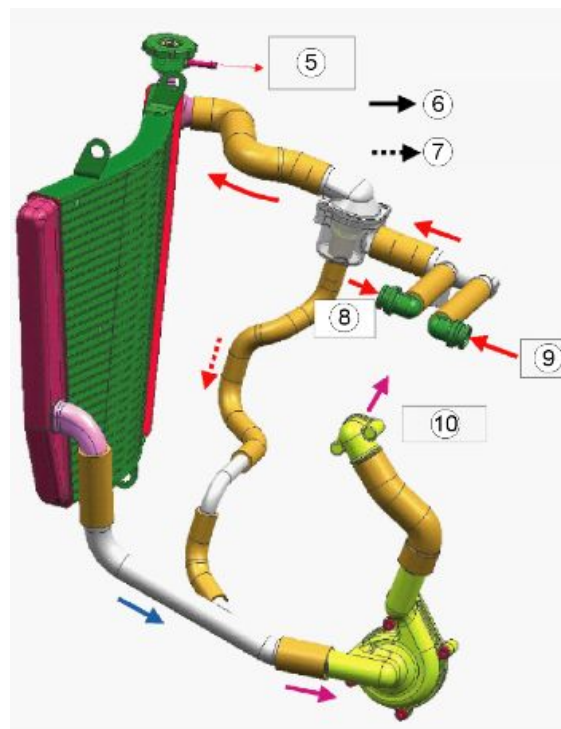
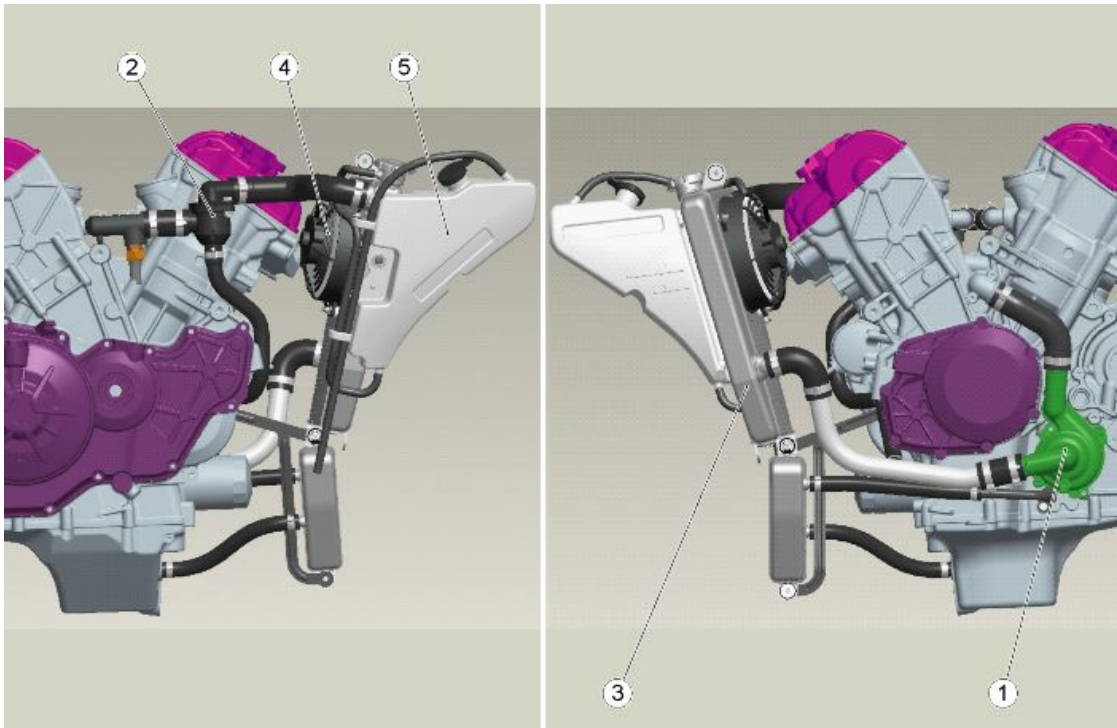

key:

1. Centrifugal pump
2. Thermostatic valve
3. Radiator
4. Electric fans
5. Expansion tank
6. With the thermostat open
7. With the thermostat closed
8. From front head
9. From rear head
10. To upper crankcase

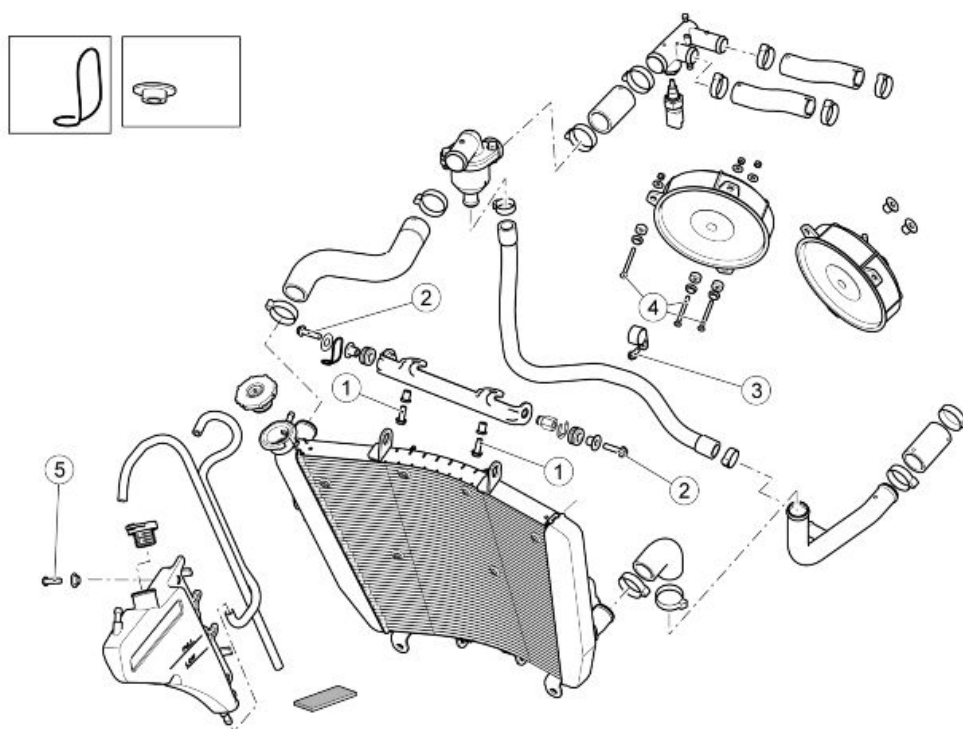

LIQUID

Pos.	Description	Type	Quantity	Torque	Notes
1	Flanged hex. head screws for fastening the water radiator support bracket to the frame	M6x20	2	10 Nm (7.38 lb ft)	-
2	Flanged hex. head screws for fastening the water radiator to the support bracket	M6x20	2	7 Nm (5.16 lb ft)	-
3	Screws for fastening the water bypass pipe tube gland	M5	1	6 Nm (4.43 lb ft)	-
4	Screws for fastening the electric fans to the water radiator	M4	6	0.5 Nm (0.37 lb ft)	-
5	Screw for fastening the expansion tank	M6	1	5 Nm (3.69 lb ft)	Loct. 243

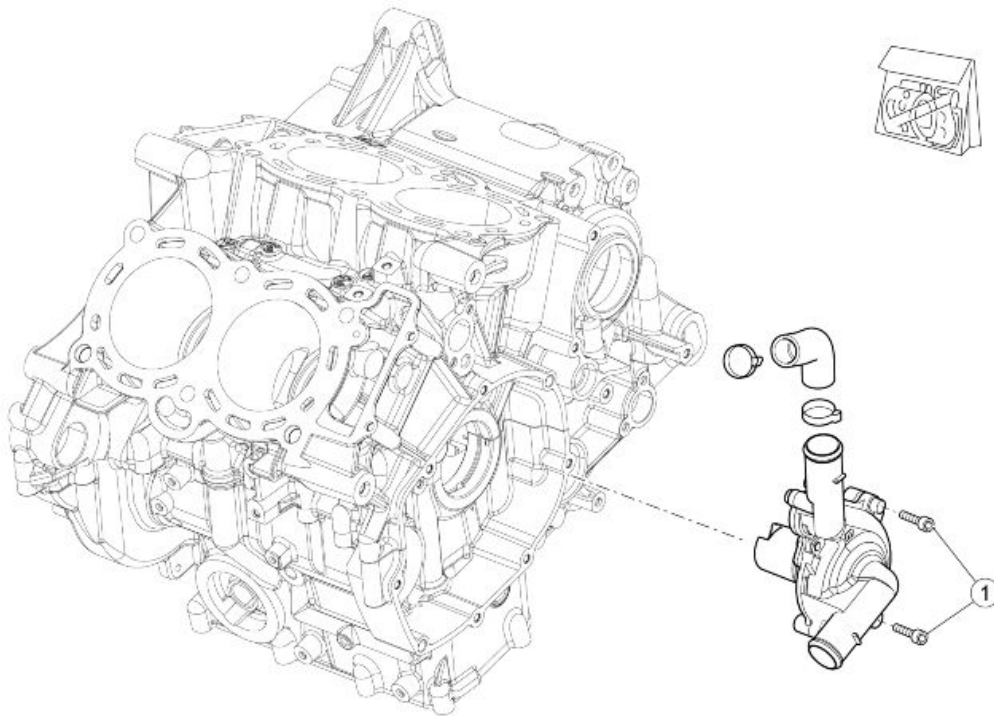
**WATER PUMP**

Pos.	Description	Type	Quantity	Torque	Notes
1	Cylindrical head, hex. socket screws for fastening the pump to the crank-case	M6x25	2	10 Nm (7.38 lb ft)	-

Electric fan

- Remove the front underfairings and the hand grip position sensor
- Disconnect the cooling fan connector to be replaced.



- Internally blocking the nuts, unscrew the fixing screw from the internal part.
- Make sure that the nuts and washers are retrieved.



See also

[Fairing mounting panels](#)
[Twistgrip position sensor](#)

- The retainer points of the electric fan are not the same as the hole (2), compared to the holes (1), has a different thickness and is therefore fixed from the internal side using a threaded "T" bushing.

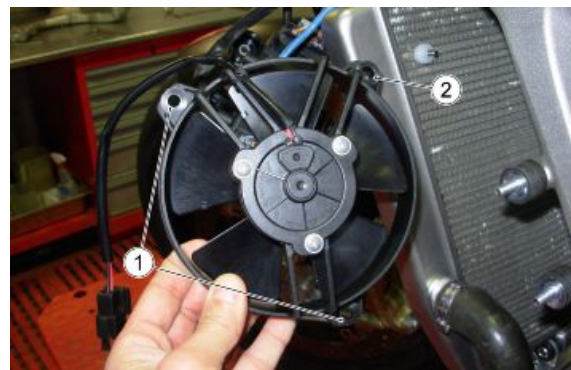

- Now it is possible to remove the electric fan.

Coolant replacement

- Remove both fairings.
- Place a container with a suitable capacity under the coolant pump.
- Remove the radiator cap/valve to help the fluid drain out.



- Unscrew and remove the system drain screw and retrieve the sealing washer.
- Wait for the entire circuit to drain (engine+pipes+radiator)
- Refit the system drain screw complete with a new washer.

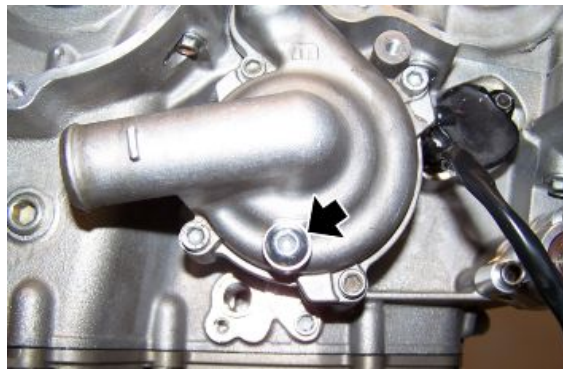

FILLING

- Via the filler orifice on the radiator, fill with the quantity of coolant (approx. 2.2 l - 0.48 UK gal) necessary to reach the edge.
- Fit the cap / valve.
- Via the filler orifice on the expansion tank, fill with the quantity of coolant necessary to reach the FULL marking, then refit the cap.
- Start the engine, run at idle speed and wait for the electric fans to activate (approx. 101 °C - 213 °F) then turn off the engine and wait for it to cool.
- With the vehicle standing vertically, check the liquid level both in the radiator and in the expansion tank and top up if necessary.



Water pump

- Drain the coolant.
- Remove the pipe from the radiator.



- Unscrew and remove the two screws fastening the pipe to the engine.
- Retrieve the gasket and replace with a new component when refitting.

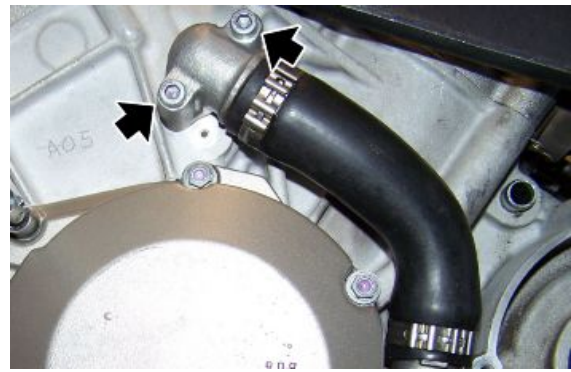

See also

Coolant replacement

- Unscrew and remove the two screws fastening the pump to the engine.
- Remove the coolant pump.

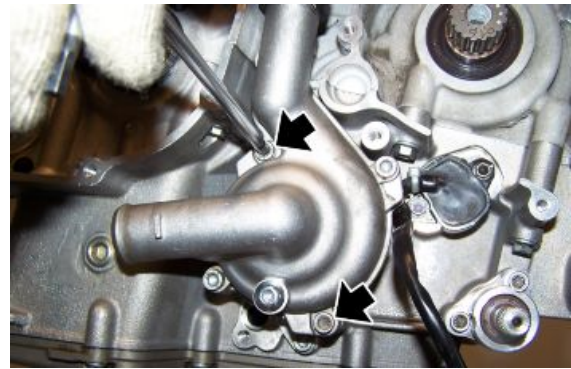

- Unscrew and remove the two external pump cover fixing screws.



- Unscrew and remove the inner screw.
- Remove the pump cover.



TO PREVENT IRREPARABLE DAMAGE TO THE PUMP, UNSCREW AND REMOVE THE INNER SCREW BEFORE REMOVING THE COVER.



- At each removal, replace the inner gasket between the pump casing and the cover and the O ring on the pump casing.



ENSURE THAT THE LIQUID PASSAGE ORIFICES ARE NOT OBSTRUCTED.



Removing the radiator

RADIATOR BRACKET REMOVAL

- Operating from the right side of the motorcycle, move the main cable harness and remove the screw fixing the radiator to the retainer bracket.



- Remove the two chassis bracket fixing screws.
- Then remove the radiator retainer bracket.

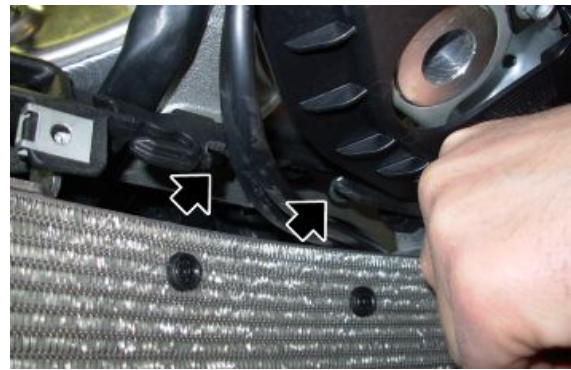

- Moving the bracket outwards, it is then possible to remove it by sliding it out.

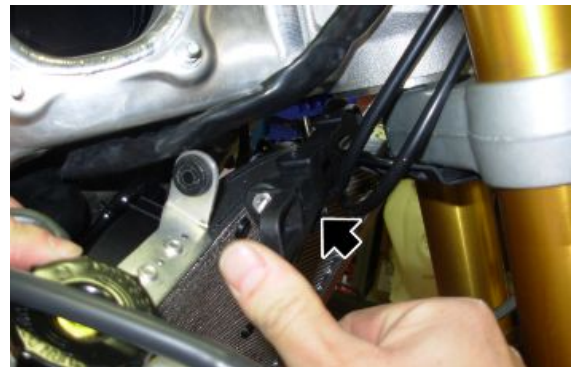
**CAUTION**

DURING THE REFIT PHASE, MAKE SURE THAT THE MAIN CABLE HARNESS IS CORRECTLY POSITIONED ON THE CAVITY OF THE RADIATOR RETAINER BRACKET, IN ORDER TO PREVENT THE CABLE HARNESS FROM COMING INTO CONTACT WITH THE RADIATOR AT HIGH TEMPERATURE AND DAMAGING ITSELF.

RADIATOR REMOVAL

- Drain off the cooling system.
- Remove the front underfairings and the hand grip position sensor
- Disconnect both cooling fan connectors.



- Disconnect the expansion tank breather pipe from the pipe grommet.

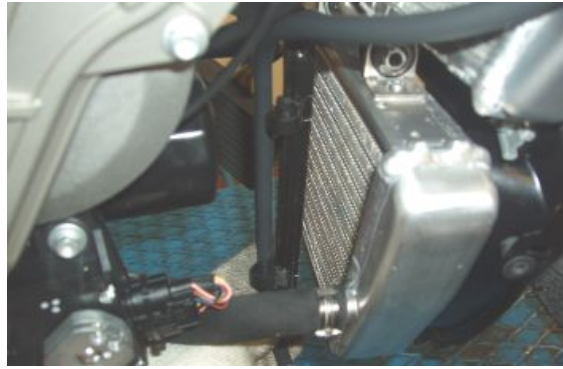

See also

Coolant replacement
[Fairing mounting panels](#)
[Twistgrip position sensor](#)

- Remove the two fixing screws of the radiator bracket.



- Cut the clamp fastening the cable harness to the radiator return pipe on the left hand side.

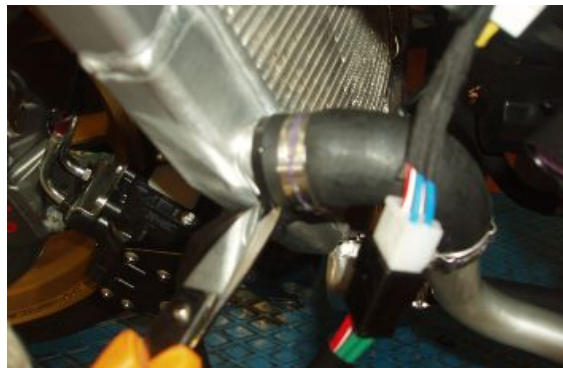

- Release the clamp fastening the return pipe to the radiator pipe



UPON REFITTING, REPLACE CLIC CLAMP REMOVED WITH A NEW ONE OF EQUAL SIZE. DO NOT REFIT THE CLIP-ON CLAMP REMOVED PREVIOUSLY AS IT IS NO LONGER USABLE. DO NOT REPLACE THE CLIP-ON CLAMP REMOVED PREVIOUSLY WITH A SCREW CLAMP OR ANY OTHER TYPE OF CLAMP.

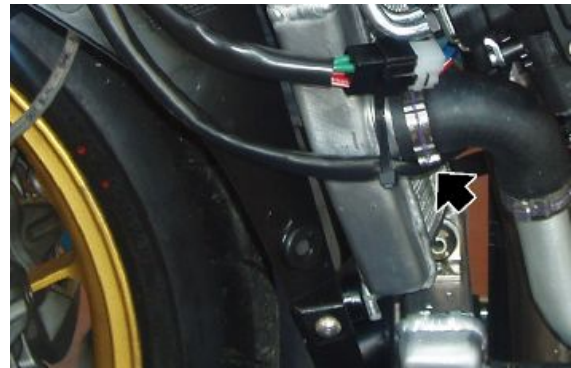

- Release the clamp fastening the delivery pipe to the radiator pipe



UPON REFITTING, REPLACE CLIC CLAMP REMOVED WITH A NEW ONE OF EQUAL SIZE. DO NOT REFIT THE CLIP-ON CLAMP REMOVED PREVIOUSLY AS IT IS NO LONGER USABLE. DO NOT REPLACE THE CLIP-ON CLAMP REMOVED PREVIOUSLY WITH A SCREW CLAMP OR ANY OTHER TYPE OF CLAMP.



- Remove the split pin.
- From the opposite site, remove the coolant radiator-oil radiator connector pin.



- Remove the radiator.

INDEX OF TOPICS

BODYWORK

BODYW

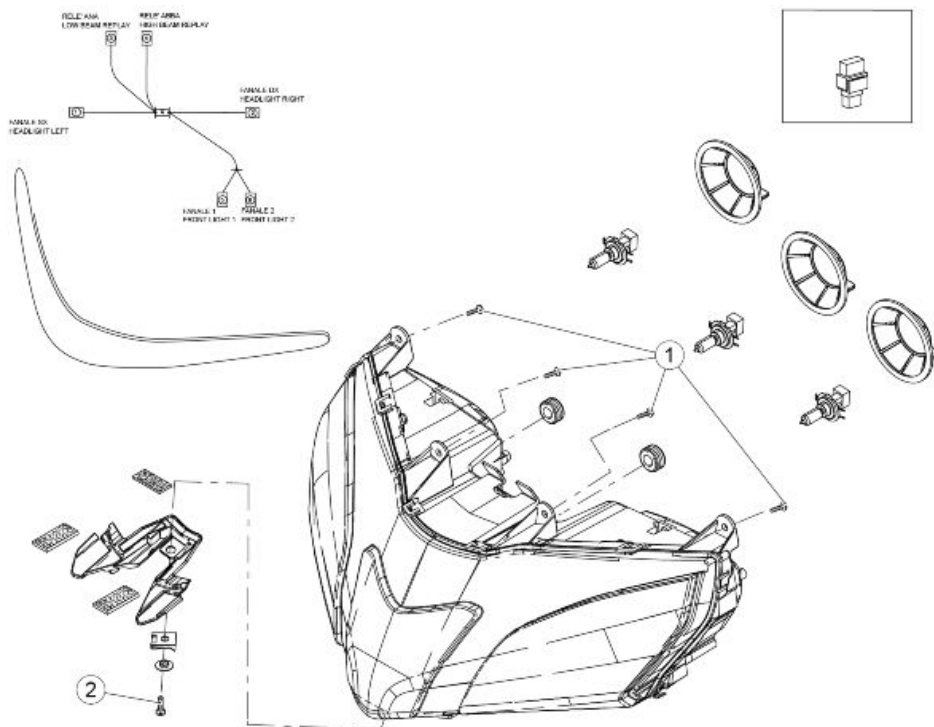

HEADLAMP

Pos.	Description	Type	Quantity	Torque	Notes
1	Screw for fastening the front headlight to the front mudguard	SWP 4.9	4	2 Nm (1.48 lb ft)	-
2	Headlamp fastener screw	M5 x 12	1	2 Nm (1.48 lb ft)	-

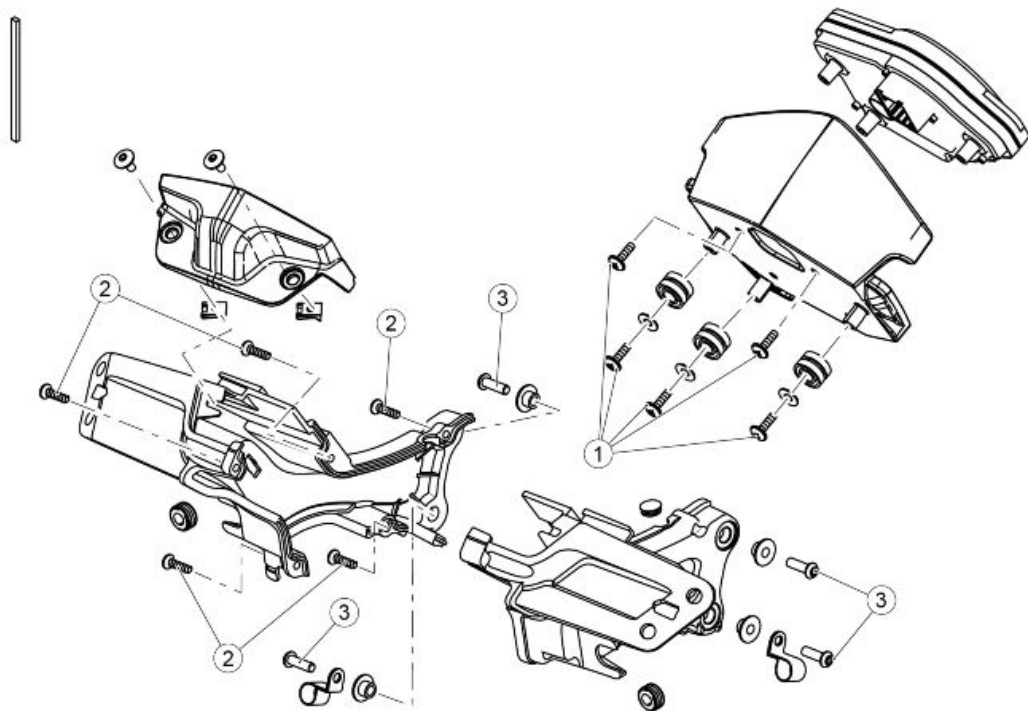

INSTRUMENT PANEL

Pos.	Description	Type	Quantity	Torque	Notes
1	Screws used to fasten the rubber blocks to the instrument panel	SWP 4.9	3	3 Nm (2.21 lb ft)	-
2	Instrument panel support shell fastening screws	SWP 4.9	5	2 Nm (1.48 lb ft)	-
3	Screws used to fasten the instrument panel support to the chassis	M6	4	8 Nm (5.90 lb ft)	-

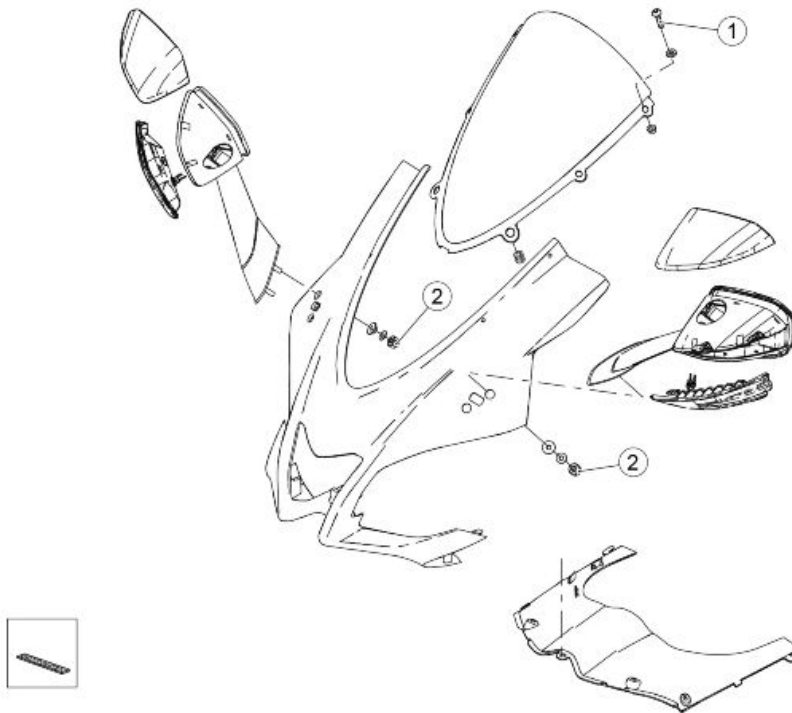
**TOP FAIRING**

pos.	Description	Type	Quantity	Torque	Notes
1	Windshield fixing screws	M4	4	0.5 Nm (0.37 lb ft)	-
2	Rear-view mirror fixing nuts	M6	2 + 2	10 Nm (7.38 lb ft)	-

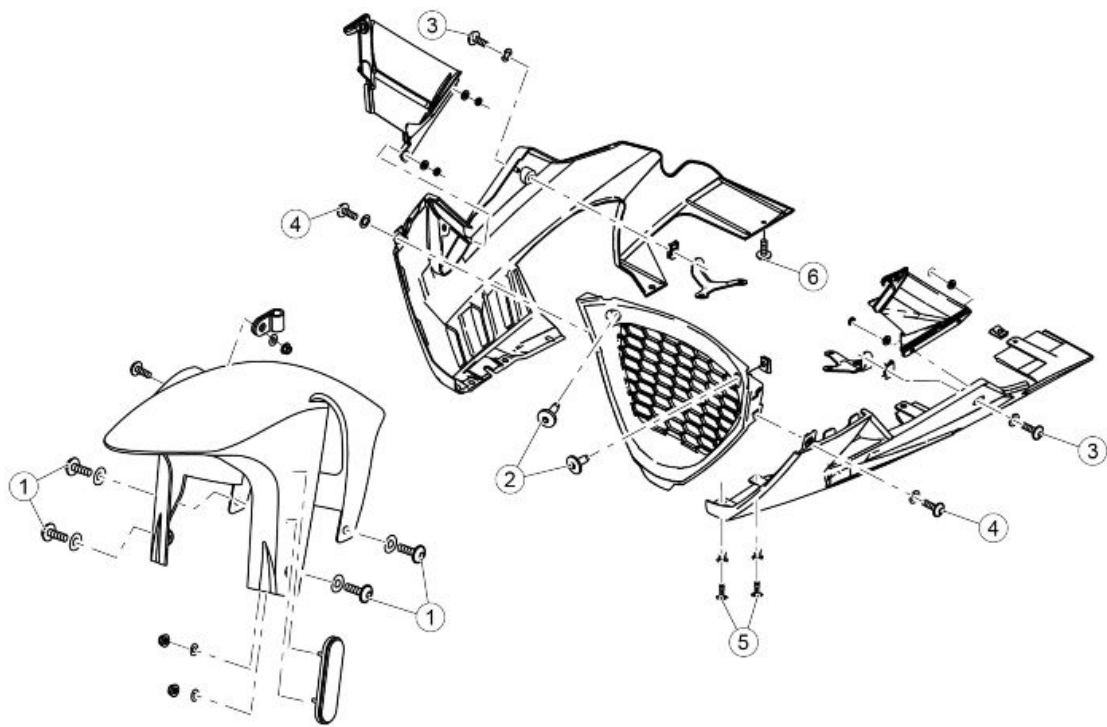

FRONT MUDGUARD

pos.	Description	Type	Quantity	Torque	Notes
1	Front mudguard fixing screws	M5	4	3 Nm (2.21 lb ft)	-
2	Lug fixing screws	M5	2	4 Nm (2.95 lb ft)	-
3	Screws fixing the side fairings to the side spacers	M5	2	1.5 Nm (1.11 lb ft)	-
4	Screws fastening the lower fairing to the lug	M5	2	2 Nm (1.48 lb ft)	-
5	Lower fairing lower fastening screws	M5	2	2 Nm (1.48 lb ft)	-
6	Centre screws fastening lower fairing	M6	2	10 Nm (7.38 lb ft)	-

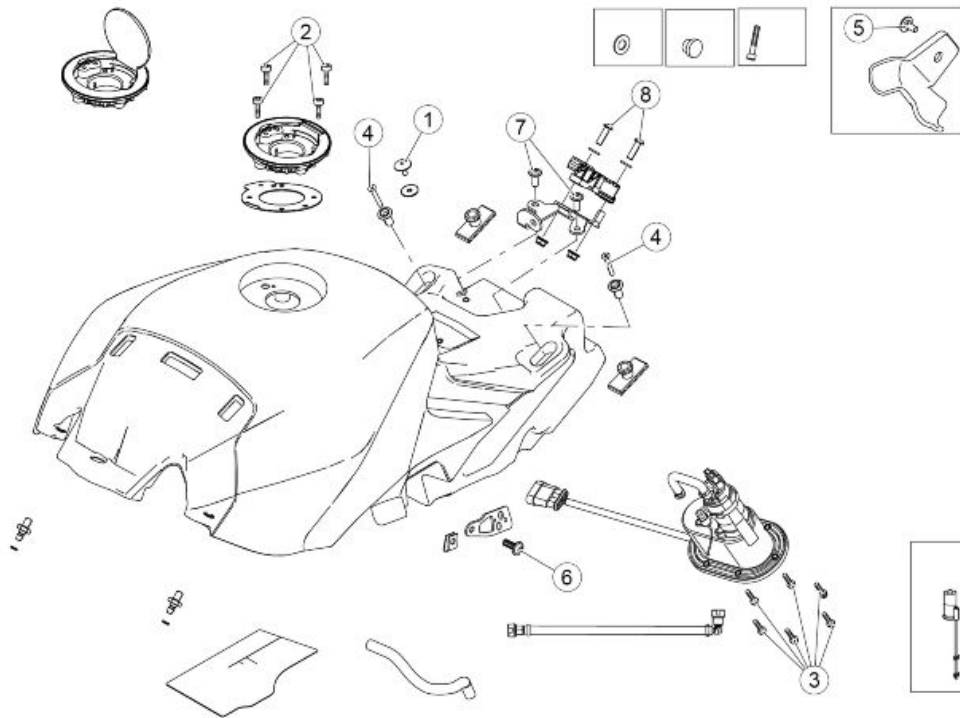

FUEL TANK

Pos.	Description	Type	Quantity	Torque	Notes
1	Special screw for fastening the rider's saddle to the fuel tank	M6	1	4 Nm (2.95 lb ft)	-
2	Filler to tank retaining screws	M5	4	4 Nm (2.95 lb ft)	-
3	Screws fastening fuel pump flange to fuel tank	M5	8	5 Nm (3.69 lb ft)	-
4	Screws fastening the rear fuel tank to the rear frame	M6	2	7 Nm (5.16 lb ft)	-
5	Plastic petrol hose support retaining screws	M5	1	2.5 Nm (1.84 lb ft)	-
6	LH fairing support bracket retaining screws	M5	1	3 Nm (2.21 lb ft)	-
7	Button head hex socket screws for fastening the sensor support to the fuel tank	M6x20	2	6 Nm (4.43 lb ft)	-
8	Flanged button head hex socket screws for fastening the sensor to the bracket	M6x12	2	6 Nm (4.43 lb ft)	-
-	Central fuel tank cover retaining screw	M4	1	0,5 Nm (0.37 lb ft)	-
-	Fuel tank breather couplings	M7	2	3 Nm (2.21 lb ft)	-
-	Fuel return coupling	M6	1	6 Nm (4.43 lb ft)	Loctite 243
-	Pump support to flange fastening	M5	3	4 Nm (2.95 lb ft)	-
-	Lug to flange fastening	M5	2	5 Nm (3.69 lb ft)	-
-	Petrol return closure	M6	1	10 Nm (7.38 lb ft)	Loctite 243
-	Petrol delivery pipe	M12x1.5	1	22 Nm (16.23 lb ft)	-
-	Petrol level sensor on pump support	SWP 2.9x12	2	1 Nm (0.74 lb ft)	-
-	Petrol pump on flange wiring	M6	2	10 Nm (7.34 lb ft)	-

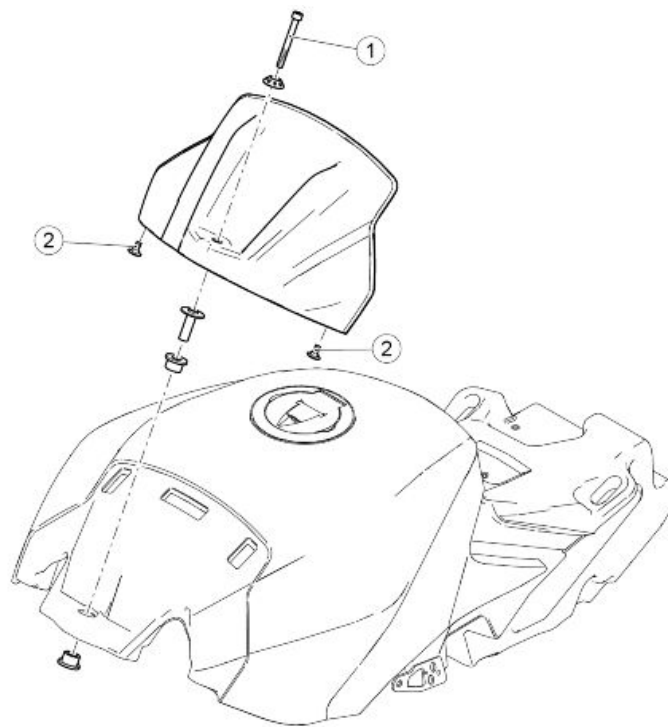

FUEL TANK COVER

Pos.	Description	Type	Quantity	Torque	Notes
1	Screws fastening front tank to frame	M6	1	8 Nm (5.90 lb ft)	-
2	Screws fastening tank structural support to tank	M6	4	3 Nm (2.21 lb ft)	-

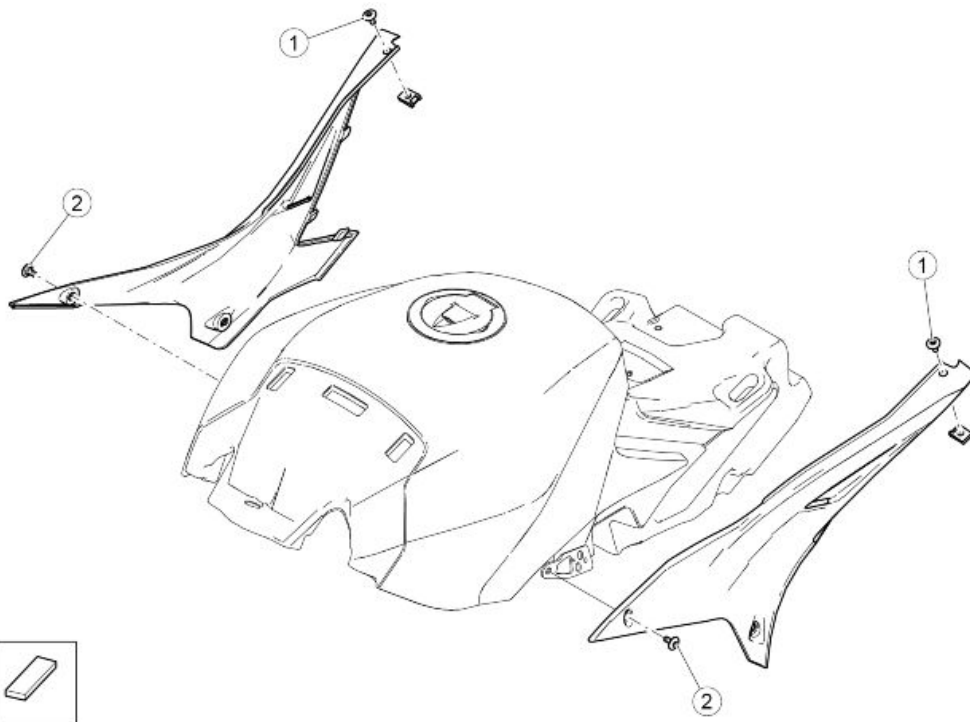

CENTRAL BODYWORK

Pos.	Description	Type	Quantity	Torque	Notes
1	Screws fastening fairing to tail fairing	M5	2	1 Nm (0.74 lb ft)	-
2	Screws fastening fairing to tank	M5	2 + 2	2 Nm (1.48 lb ft)	-

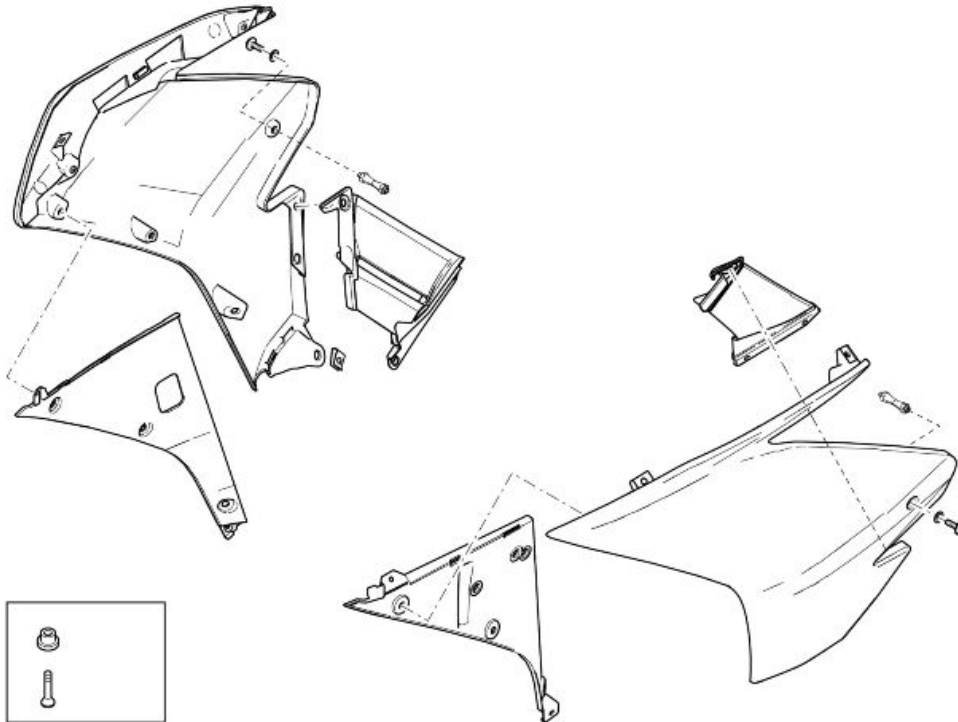
**FAIRING**

Pos.	Description	Type	Quantity	Torque	Notes
-	Fairing retaining spacer	M6	2	8 Nm (5.90 lb ft)	-
-	Lower fairing central bracket fastening screws	M6	2	10 Nm (7.38 lb ft)	-
-	RH lower fairing support bracket	M6	2	12 Nm (8.85 lb ft)	-
-	LH lower fairing support bracket	M6	2	12 Nm (8.85 lb ft)	-
-	Screws for fastening the side fairings to the lateral spacers	M5	2	1.5 Nm (1.11 lb ft)	-
-	Screws for securing the upper fairing closure to the intake duct	M5	2	1.5 Nm (1.11 lb ft)	-
-	Screws for securing the upper fairing closure to the front mudguard	M5	2	1.5 Nm (1.11 lb ft)	-
-	Screws for securing the upper fairing closure to the intake duct	self-tapping	2	1 Nm (0.74 lb ft)	-
-	Screws for securing the upper fairing closure to the front headlight	self-tapping	2	1 Nm (0.74 lb ft)	-
-	Screws for fastening the lower fairing to the bracket	M5	2 + 2	1 Nm (0.74 lb ft)	-
-	Screws for fastening the lower fairing to the stanchion	M5	2	2 Nm (1.47 lb ft)	-
-	Lower fairing fastening screws	M5	2	2 Nm (1.47 lb ft)	-
-	Lower forks closure fastening screws	M6	2	8 Nm (5.90 lb ft)	-
-	Screws for fastening the lower frontal closure to the intake ducts	SWP 3,9	2	1 Nm (0.74 lb ft)	-
-	Internal fastening screws between the fairing and the lower frontal closure	M4	2	0,5 Nm (0.37 lb ft)	-
-	Internal fastening screws between the airing and the stanchion	M5	2	2 Nm (1.48 lb ft)	-

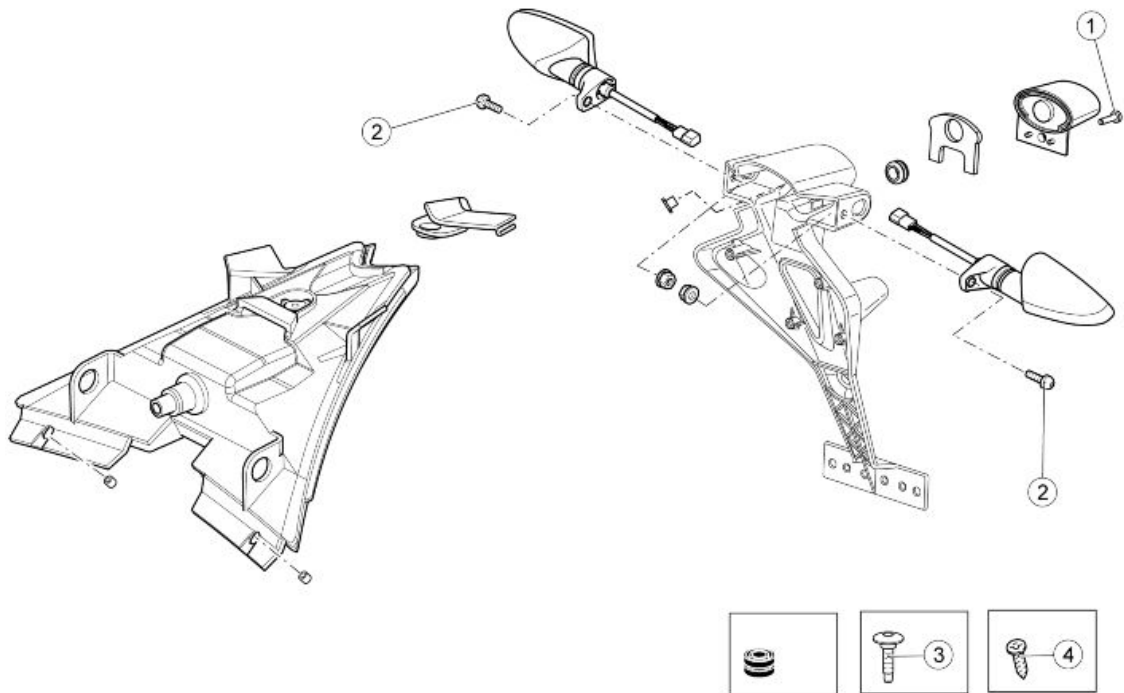

LICENSE PLATE HOLDER

pos.	Description	Type	Quantity	Torque	Notes
1	License plate light fixing screws	M4	1	1 Nm (0.74 lb ft)	-
2	Rear turn indicator fixing screws	M6	2	2.5 Nm (1.84 lb ft)	-
3	Taillight fixing screws	M5	2	3 Nm (2.21 lb ft)	-
4	Taillight cover self-tapping fixing screw	SWP 3.9	1	0.5 Nm (0.37 lb ft)	-
-	Screws fastening license plate mounting to saddle mounting casting	M6	3	4 Nm (2.95 lb ft)	-

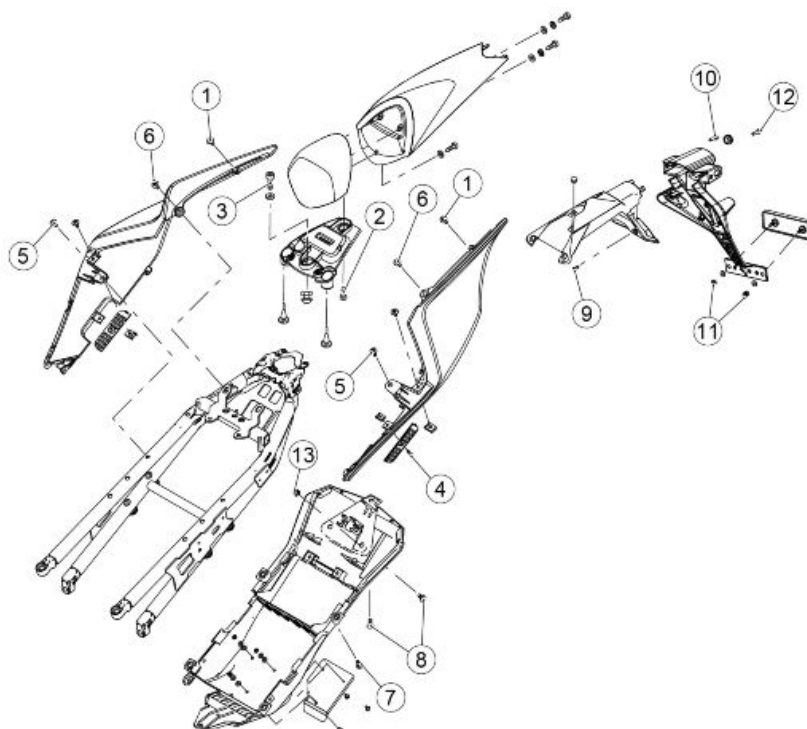

REAR BODYWORK

Pos.	Description	Type	Quantity	Torque	Notes
1	Rear screws used to fasten the tail fairing to the rear headlight bracket	M5	2	3 Nm (2.21 lb ft)	-
2	Screws used to fasten the saddle cover base to the saddle cover	SWP 2.9	3	1 Nm (0.74 lb ft)	-
3	Saddle cover stud fastening screws	M4	1	1.5 Nm (1.11 lb ft)	-
4	Screws used to fasten the grilles to the tail fairing	M5	2	0.5 Nm (0.37 lb ft)	-
5	Screws for fastening the grilles to the saddle mounting	M5	2	3 Nm (2.21 lb ft)	-
6	Screws used to fasten the tail fairing to the saddle support bracket	M5	2	2 Nm (1.48 lb ft)	-
7	Lower saddle mounting closure fastening screws	M5	2	3 Nm (2.21 lb ft)	-
8	Screws for fastening number plate holder to the saddle mounting plate	M6	2	4 Nm (2.95 lb ft)	-
9	Screws for fastening the rear number plate holder to the front number plate holder	SWP 3,9	4	1 Nm (0.74 lb ft)	-
10	Self-tapping screws for fastening the rear number plate holder to the front number plate holder	SWP 4.9	2	2 Nm (1.48 lb ft)	-
11	Reflector retaining nuts	M4	2	1 Nm (0.74 lb ft)	-
12	License plate light fixing screw	M4	1	1 Nm (0.74 lb ft)	-
13	Nuts for fastening the number plate holder to the saddle mounting	M6	2	4 Nm (2.95 lb ft)	-
-	Screw for fastening the tail fairing to the taillight bracket	M5	2	3 Nm (2.21 lb ft)	-
-	V4-MP control unit retaining screws (if fitted)	Self-tapping Di-am. 3.9	2	0.3 Nm (0.22 lb ft)	-

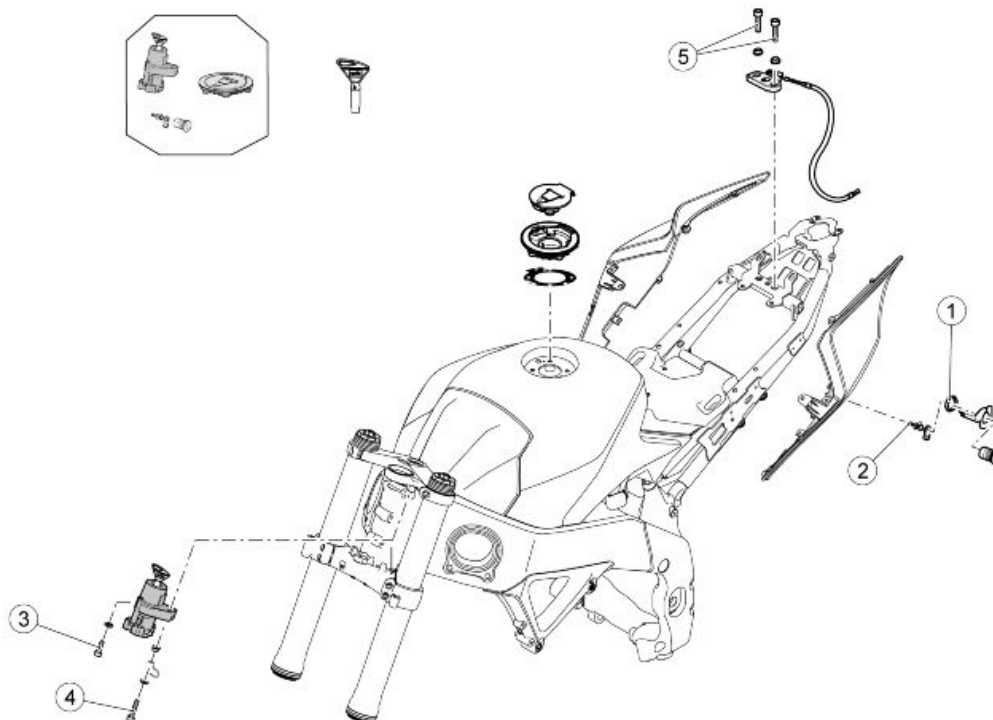

Locks

pos.	Description	Type	Quantity	Torque	Notes
1	Nut fastening saddle lock to tail fairing	M22x1.5	1	5 Nm (3.69 lb ft)	-
2	Lock lever self-tapping screw	M4	1	2 Nm (1.48 lb ft)	-

pos.	Description	Type	Quantity	Torque	Notes
3	Shear head screw (to the left of the ignition lock)	M8	1	Manual	Tighten until the head shears off
4	Right hand ignition lock screw	M8	1	20 Nm (14.75 lb ft)	-
5	Passenger saddle fixing screws	M6	2	8 Nm (5.90 lb ft)	-

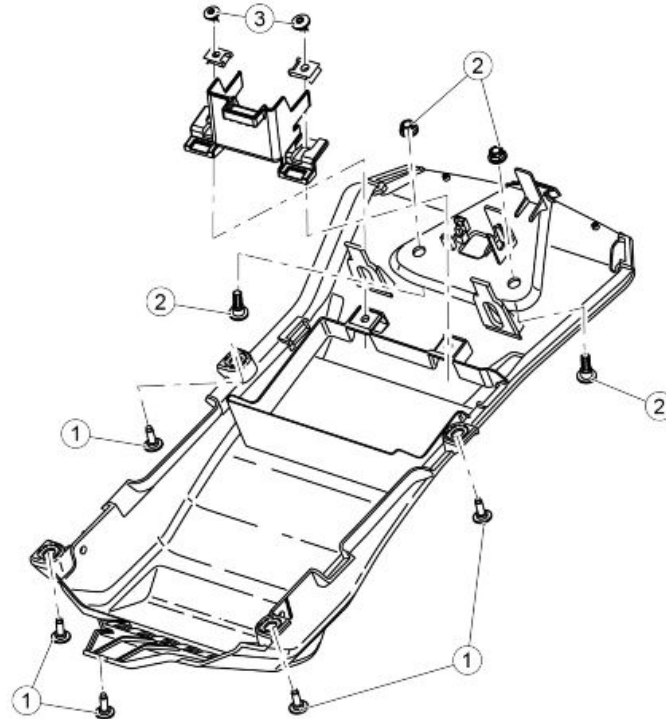

BODYWORK UNDER SADDLE

Pos.	Description	Type	Quantity	Torque	Notes
1	Flanged button head hex. socket screws for fastening the saddle mounting	M5x12	5	3 Nm (2.21 lb ft)	-
2	Screws and nuts for fastening the number plate holder to the saddle mounting plate	M6	2	4 Nm (2.95 lb ft)	-
3	Button head hex socket battery bracket fastening screws	M5	5	2 Nm (1.48 lb ft)	-

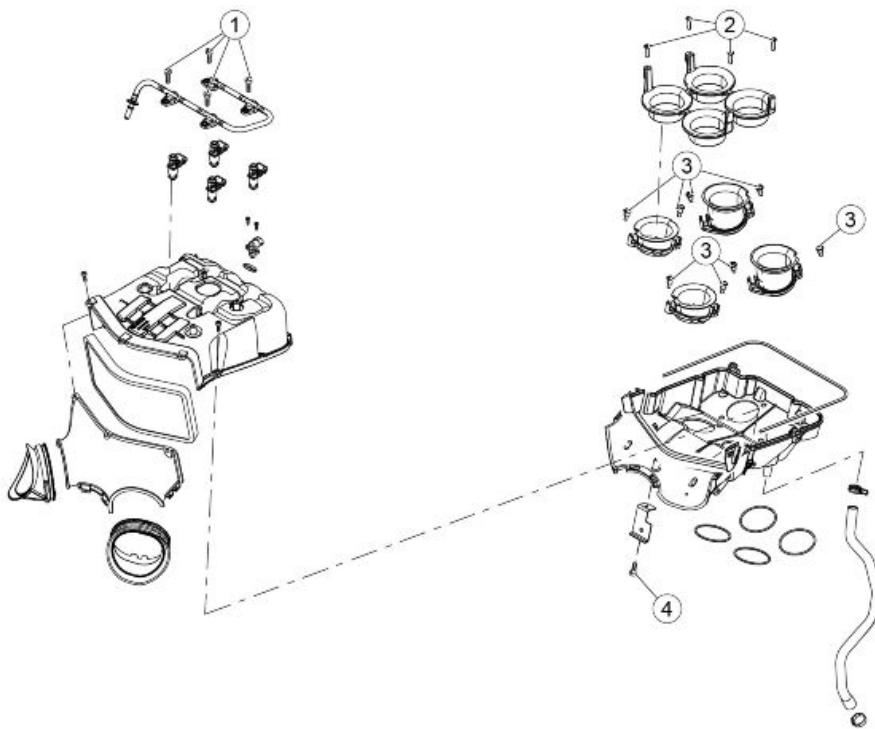

FILTER BOX

Pos.	Description	Type	Quantity	Torque	Notes
1	Flanged SWP petrol/injectors circuit fastening screws	M5x20	4	... Nm (... lb ft)	-
2	Flanged SWP upper intake ducts retaining screws	M5x20	4	... Nm (... lb ft)	-
3	Flanged SWP lower intake ducts retaining screws	-	4	... Nm (... lb ft)	-

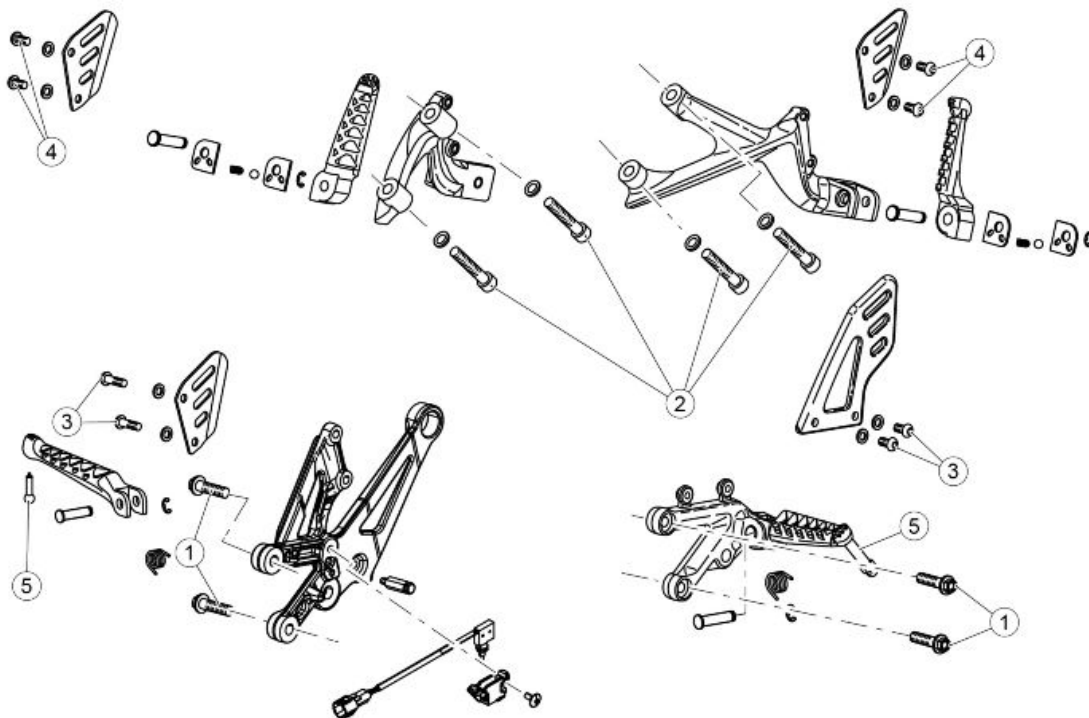

FOOTRESTS

Pos.	Description	Type	Quantity	Torque	Notes
1	Screws for fastening the rider's footrests to the frame	M8	2 + 2	25 Nm (18.44 lb ft)	Loctite 243
2	Screws for fastening the passenger's footrests to the frame	M8	2 + 2	18 Nm (13.28 lb ft)	Loctite 243 - For use in countries where it is mandatory to fit the passenger's footrests or for the two-seater configuration
3	Rider's heel guard retaining screws	M6	2 + 2	8 Nm (5.90 lb ft)	-
4	Passenger's heel guard retaining screws	M6	2 + 2	8 Nm (5.90 lb ft)	-
5	Anti-creep pin	M6	1	8 Nm (5.90 lb ft)	-

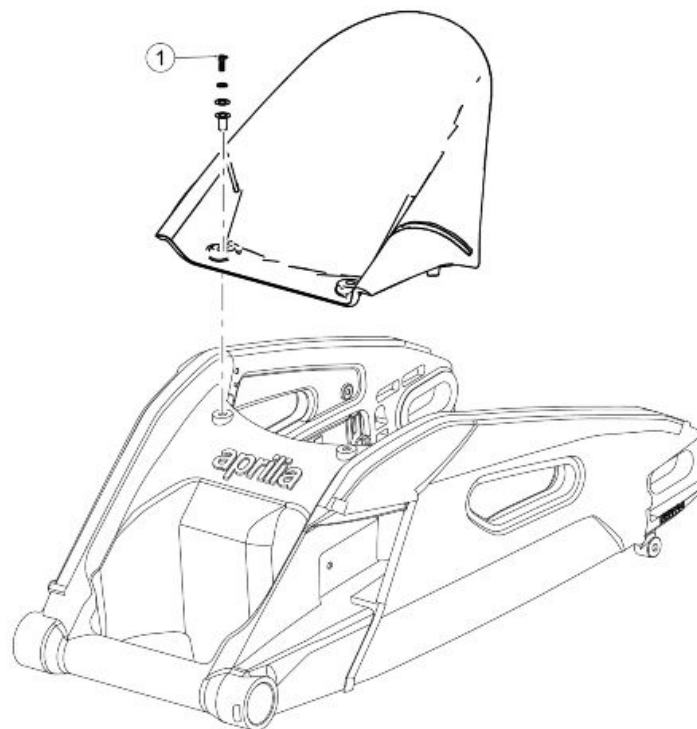

REAR MUDGUARD

pos.	Description	Type	Quantity	Torque	Notes
1	Rear mudguard fixing screws	M6	2	5 Nm (3.69 lb ft)	For plastic mudguard
1	Rear mudguard fixing screws	M6	2	3 Nm (2.21 lb ft)	For carbon mudguard

Seat

- Remove the saddle cover/ passenger saddle
- Remove the two rear fastening screws

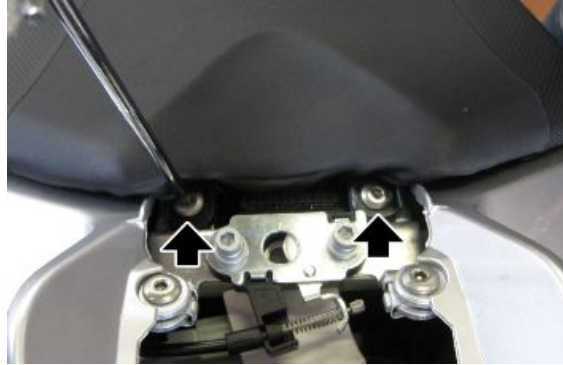

- Lift the rear saddle and slide it off the pin on the tank



Driving mirrors

- The following procedure is for a single rear view mirror, but is applicable to both mirrors.
- Disconnect the turn indicator connector from the relative fixed connector on the instrument panel
- Unscrew and remove the two nuts, supporting the rear view mirror.



- Guiding the turn indicator cable through the relative hole on the top fairing, remove the rear view mirror.



Instrument panel

- Remove the windshield.
- Unscrew and remove the two screws.



- Remove the instrument panel mounting cover.
- Move the instrument panel, removing the rubber rings from the seats on the support.



- Rotate the instrument panel connector retainer lever.
- Remove the connector.
- Remove the instrument panel.



NOTE

WHEN REASSEMBLING THE CONNECTORS, THE SLIDES MUST SLIDE FREELY UP TO THE LIMIT STOP, THUS FACILITATING THE CONNECTOR'S INSERTION. THE CATCH SHOULD SNAP INTO PLACE ONCE THE LIMIT STOP IS REACHED.

Headlight assy.

- Remove the top fairing complete
- Remove the side air deflectors from the top fairing
- Remove the four fixing screws (1)



- Remove the lower fixing screw (2) paying attention to collect the bush (3)

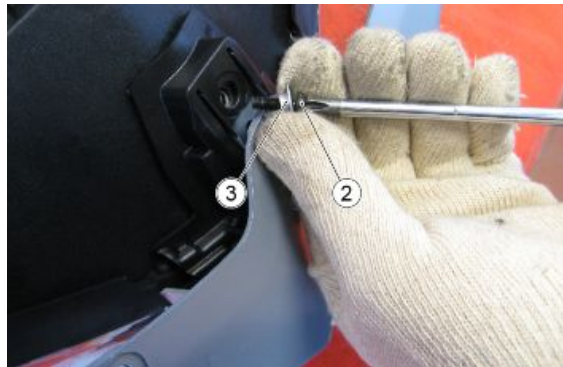

- Remove the headlight assembly complete (4)

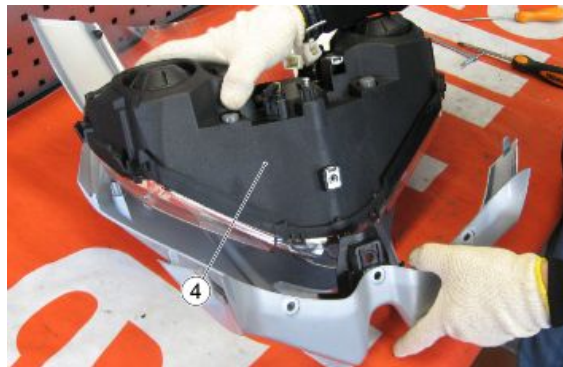

- Slide off the support (5) of the headlight from the top fairing



Headlight fairing

- Previously remove the side fairings
- Operating from the left side of the motorcycle, remove the rear screw (1) fixing the top fairing to the air deflector



- Remove the upper screw (2) fixing the top fairing to the air deflector



- Remove the central screw (3) fixing the top fairing to the support frame



- Remove the previously described screws also for the right side of the motorcycle

-
- Remove the three clips (4) under the top fairing, which are fixing it to the central underfairing

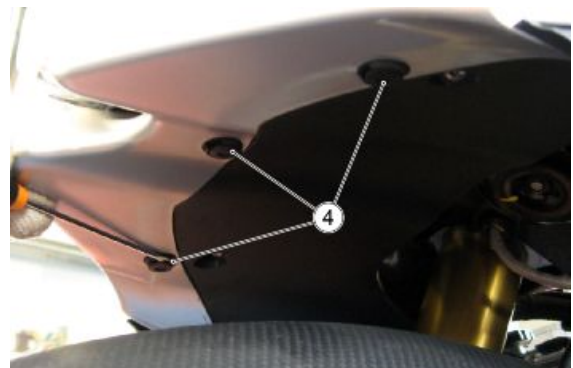

- Move the top fairing forward to the minimum space necessary to work on the front bulb connectors
- Disconnect the front headlamp connectors (5)



- Remove the top fairing complete



SIDE AIR DEFLECTOR COVERS

- To disassemble the side air deflector covers connected to the top fairing, the lower screw (1) must be removed



- Remove the inner screw (2)



- Detach and remove the side air deflector covers from the top fairing



- Remove the previously described screws also for the right side of the top fairing to remove the side air deflector covers

PLEXIGLAS

- Remove the four fixing screws paying attention to collect the Teflon washers



- Slide the plexiglas from the lower pins and remove it



Taillight assy.

- Carry out the tail fairing removal procedure.
- Unscrew and remove the two screws (1).

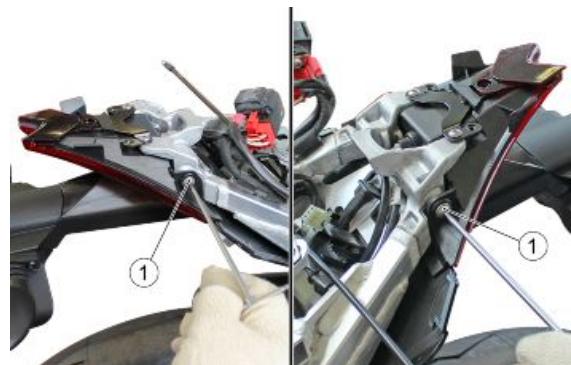

- Unscrew and remove the two screws (2).
- Remove the bracket (3).

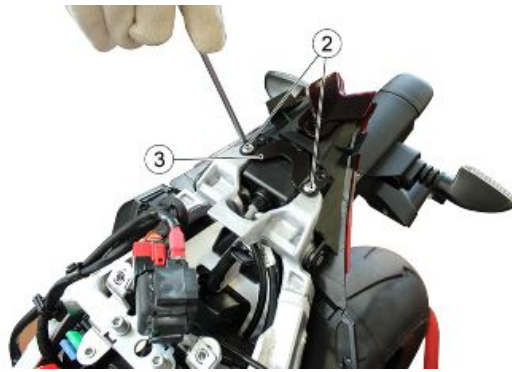

- Disconnect the connector (4).
- Remove the taillight (5).



Rider footrest plate

LEFT RIDER FOOTREST REMOVAL - GEAR-BOX LEVER

- Remove the fuel tank
- Loosen the screw (1) and ease off the gear lever



- Remove the three fixing screws (2) of the pinion cover (3)

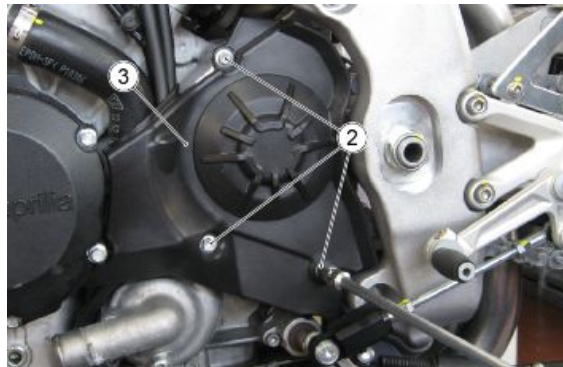

- Remove the fixing screw (4) of the cable grommet (5)



- Cut the two clamps (6) that connect the wiring of the quick-shift to the wiring of the side stand and of the lambda probe

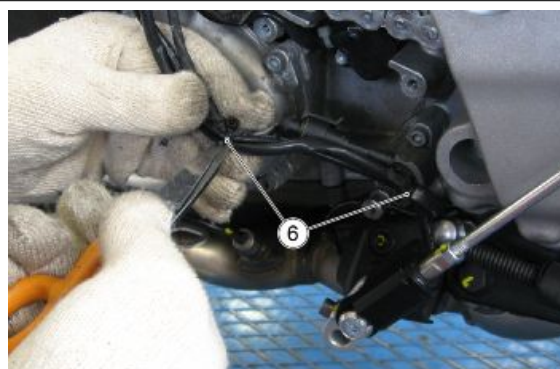

- Disconnect the connector (7) of the quick-shift and release the wiring



- Remove the two fixing screws (8) of the footrest complete with leverage



- If necessary, you can loosen and remove the quick-shift fixing screw to change the O-rings.

NOTE

NOTE THE WIRING HARNESS DOES NOT NEED TO BE DISCONNECTED FOR THIS OPERATION

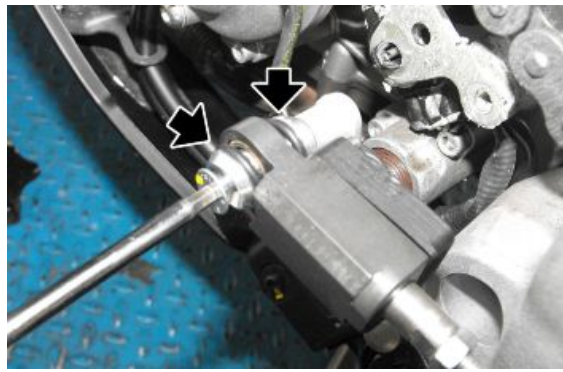
**Side body panels**

- Remove the rider saddle
- Working from the left side of the motorcycle, remove the three fixing screws of the side fairing



- Remove the side fairing



- To remove the right side fairing, perform the previously described operations

Side fairings

- Operating from the left side of the motorcycle, detaching the three clips (1) placed on the inner fairing.



- Remove the four screws (2)



- Detach the inner fixing clip (3) with the air deflector



- Slide the side fairing paying attention to the fittings with the lug



AIR DEFLECTORS

- The following operations are valid for both air deflectors
- Remove the screw (1) fixing the deflector to the lower fairing
- Remove the deflector (2)



Fairing mounting panels

- Previously remove the side fairings

LATERAL UNDERFAIRINGS

- Working from the left side of the motorcycle, remove the clamp (1) locking the wiring of the connectors (2) of the alternator to the radiator.

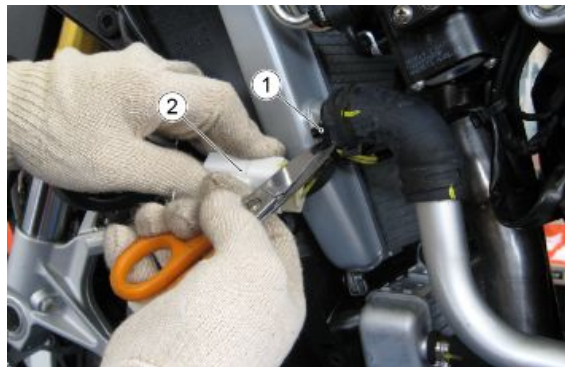

- Disconnect the connectors (2) of the alternator to the radiator



- Remove the lower fixing screw (3) of the left inner fairing



- Remove the upper fixing screw (4) of the left inner fairing



- Detach the internal left fairing (5) from the central underfairing and remove it



CENTRAL UNDERFAIRING

- Remove the three clips (1) and the two screws (2) fixing the central underfairing to the top fairing.

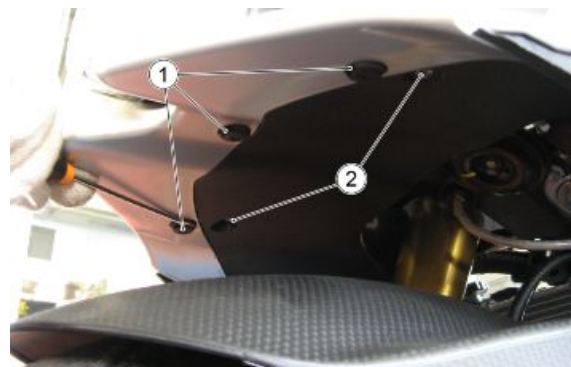

- In case the side underfairing are not removed, remove the internal screws (3) from both sides.
- Ease off the central underfairing, taking care not to damage the fittings with the lateral underfairings and the top fairing



REAR UNDERFAIRING

- Carry out the tail fairing removal procedure.
- Remove the starter relay box (1) from the point indicated in the figure.

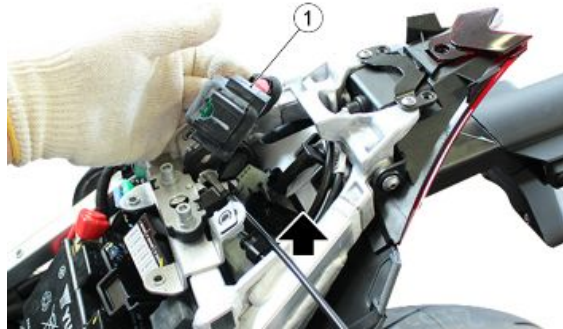

- Remove the rear light unit.
- Carry out the licence plate support removal procedure.
- Remove the tank.
- Remove the battery.
- Working from both sides of the motorcycle, undo and remove the two screws (2).

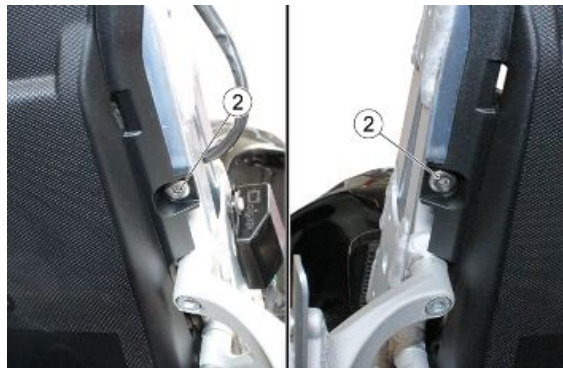

- Working from both sides of the motorcycle, undo and remove the two screws (3).

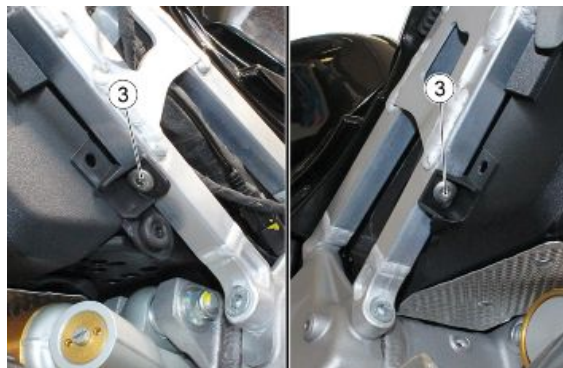

- Remove the two auxiliary fuse boxes (4) from the corresponding supports indicated in the figure.

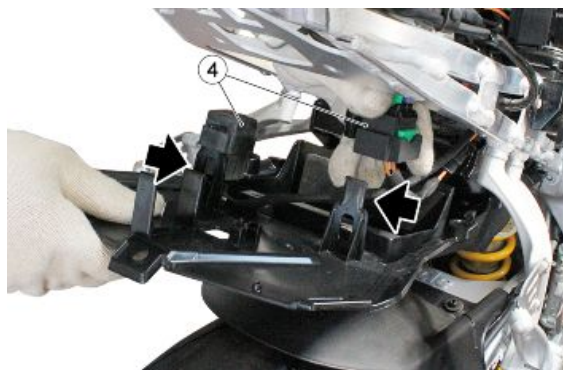

- Unscrew and remove the screw (5).



- Unhook the underfairing (6) from the point indicated in the figure.

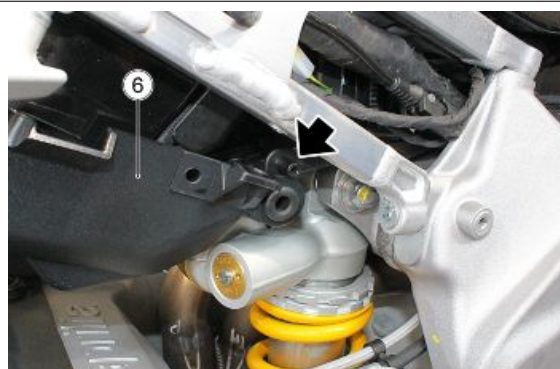

- Remove the underfairing (6).

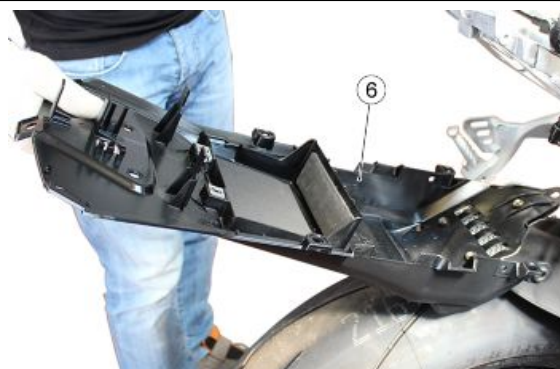

License plate holder

- Remove the plastic cover (1).



- Undo and remove the screw inside of the point indicated in the figure.
- Unscrew the fixing screws (2) together with the nuts (3).

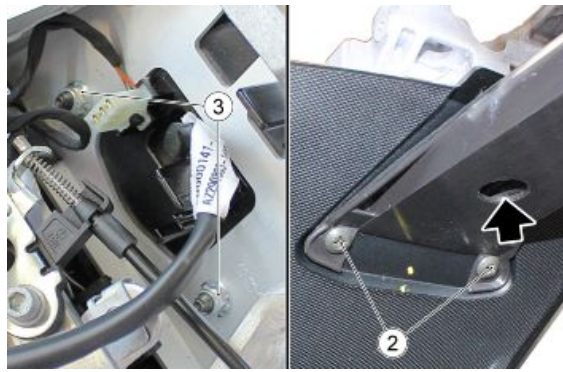

- Disconnect the connector (4).
- Remove the support (5).



Air box

FILTER BOX COVER REMOVAL

- Remove the control unit complete with support.
- Undo the four screws fixing the injectors unit to the filter box

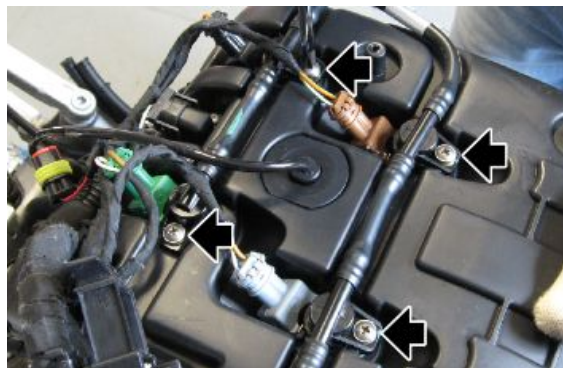

- Remove the injectors from the filter box

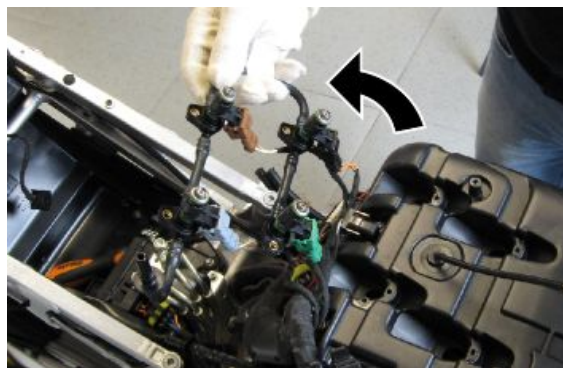

- Disconnect the air temperature sensor connector

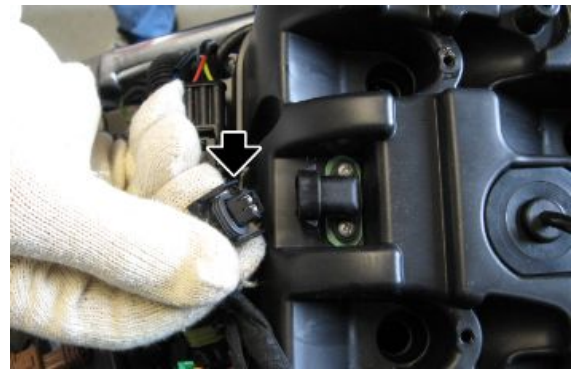

- Remove the screw fixing the wiring harness to the filter box and move it away



- Unscrew and remove the eight air filter box cover screws

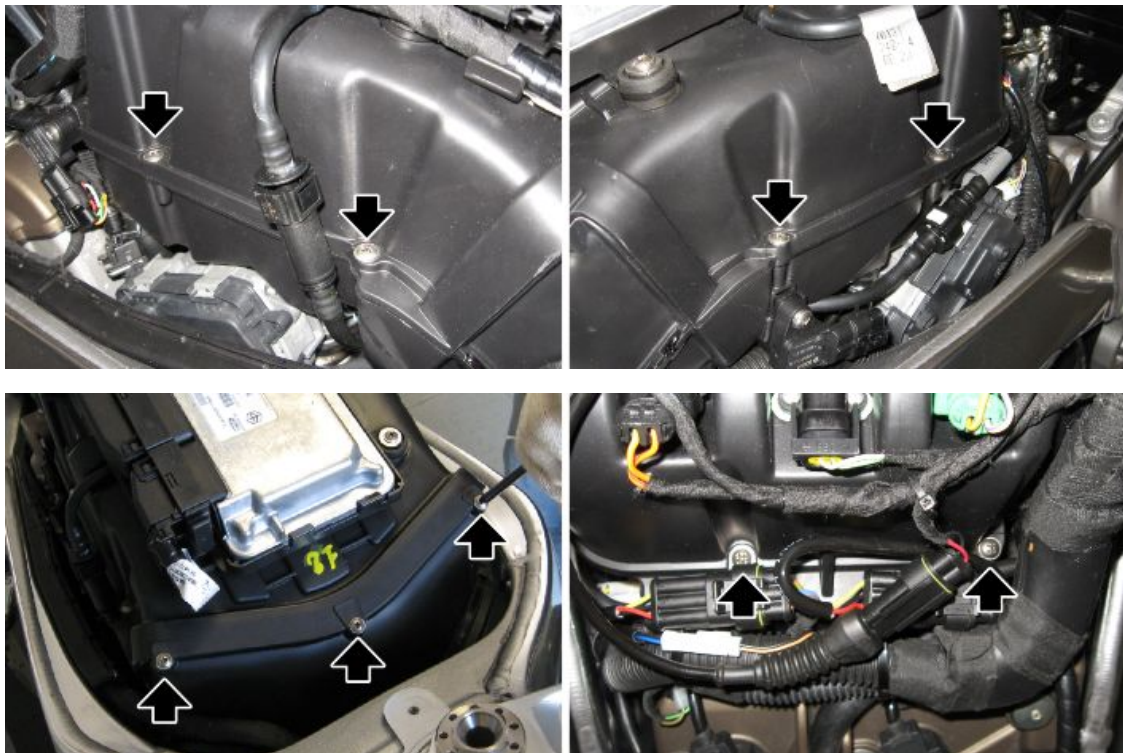

- Move the two rear coil connectors.

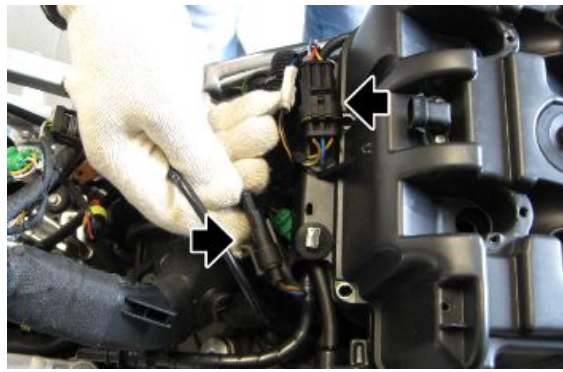

- Remove the two clamps blocking the wiring harness to the filter box cover



- Remove the four screws fixing the variable geometry intake system and remove it

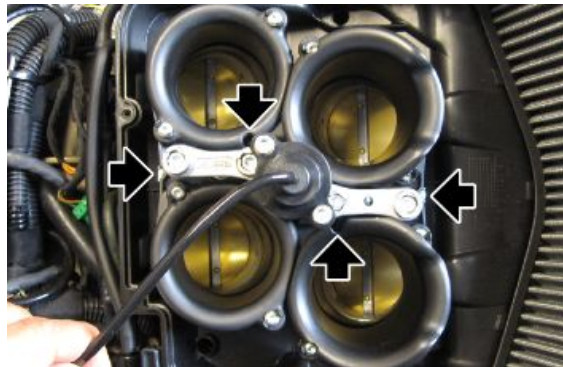

- Remove the fixing screws of the intake duct/supports

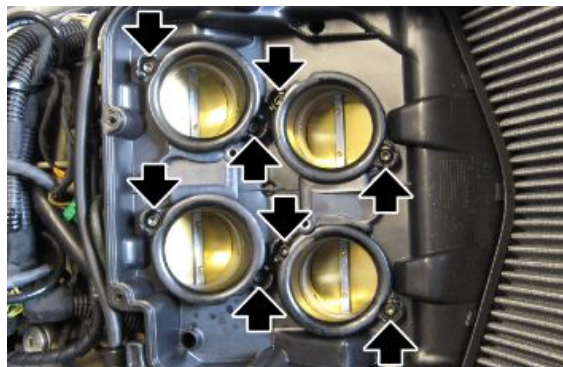

- Remove the intake ducts complete with support



- Operating from both sides, unscrew and remove the air pressure sensors fixing screws



- Operating from both sides, unscrew and remove the air pressure sensors fixing screws



- Operating from the left side of the motorcycle, remove the clamp blocking the main wiring harness to the filter box



- Disconnect the engine wiring connector, previously placed on the filter box

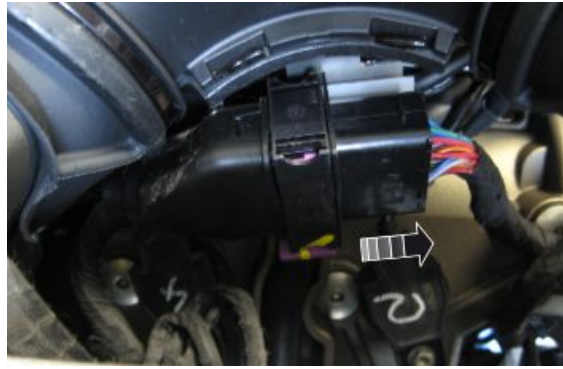

- Release the cable harness from the cable grommet on the filter box



- Remove the filter box



Rear mudguard

- Unscrew and remove the two screws.
- Remove the rear mudguard.



Lower cowl

- Remove the side fairings
- Operating from both sides, remove the front fixing screws (1)



- Remove the lower fixing screw (2) holding the lug



- Remove the clip (3) and the two screws (4) to divide the lug

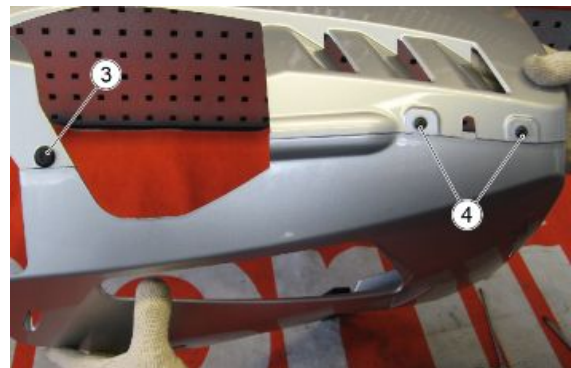

Fuel tank

- Remove the saddle.
- Unscrew and remove the front screw fixing the tank.



- Unscrew and remove the two rear screws.

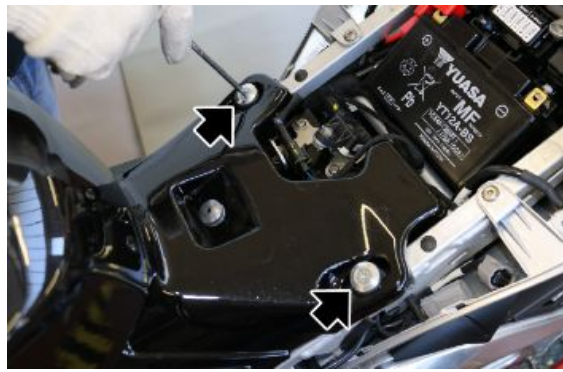

- Uncouple from its support the connector (1) of the fuel pump and disconnect it.



- Disconnect the connector (2) of the inertia platform.



- Working on the left side, disconnect the tank's two vent pipes.

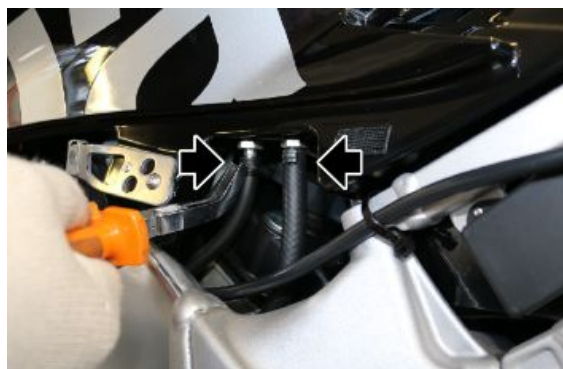

- Slightly lift the fuel tank and working on the right side of the motorcycle, disconnect the fuel pipe at the coupling point.
- Remove the tank.



Front mudguard

- Working on both sides of the vehicle, undo and remove the two screws.



- Remove the cable clamp fixing screw (if fitted)

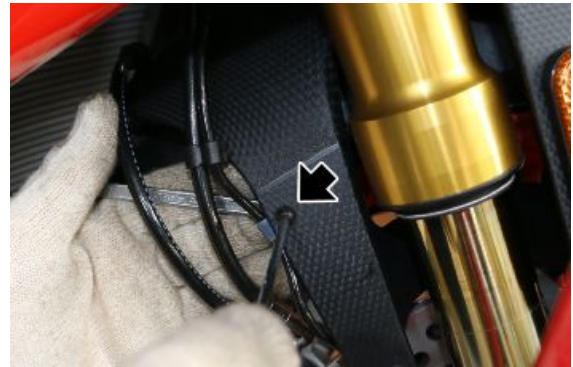

- Release the brake pipe by detaching the cable clamp from the mudguard



- Remove the front mudguard.



Instrument cluster support

REMOVAL

- Remove the instrument panel.
- Working on both sides, unscrew and remove the two screws fastening the arch brace to the headstock.
- Retrieve the cable grommet.

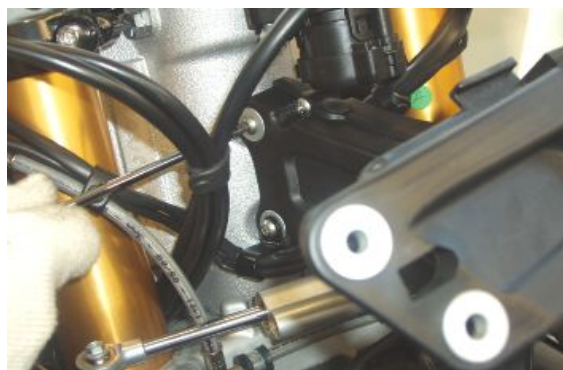

- Unscrew and remove the five semi-arch brace fixing screws.



See also

Instrument panel

- Separate and remove the two semi-arch braces



FITTING

- Fit the right semi-arch brace, fixing it to the headstock with two screws.



- Connect the Immobilizer aerial cables.



- Fasten the main cable harness to the semi-arch brace with a clamp.

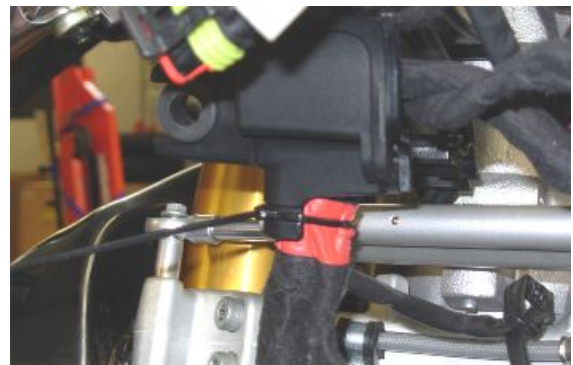

- Gather the cables on the right semi-arch brace and fasten them provisionally with a clamp.
- Fit the left semi-arch brace, applying the five coupling screws. Do not strain the connection between the two semi-arch braces, as this would prevent the removal of the clamp.



- Cut and remove the provisional clamp.
- Fit the cable grommet from the left hand side of the arch brace, tighten the two screws on the headstock.
- Tighten the five coupling screws.



- Fit the turn indicator connectors in the relative housings, noting the colours of the wires identifying the correct side.

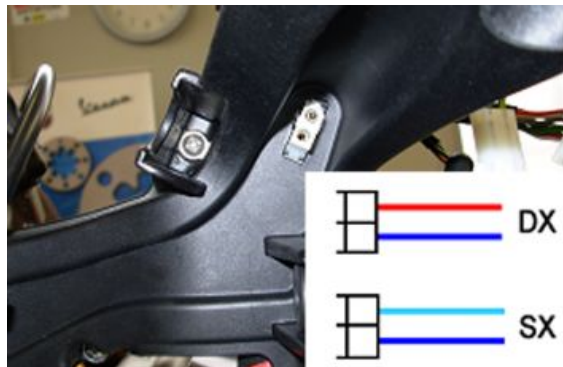

- Join the remaining connectors and arrange the cable carefully in the space available within the arch brace. Note that there are two pairs of connectors which may be connected incorrectly.

The male connector on the cable with the red strip must be connected to the female connector on the longer cable.



- Reconnect the instrument panel connector

NOTE

WHEN REASSEMBLING THE CONNECTORS, THE SLIDES MUST SLIDE FREELY UP TO THE LIMIT STOP, THUS FACILITATING THE CONNECTOR'S INSERTION. THE CATCH SHOULD SNAP INTO PLACE ONCE THE LIMIT STOP IS REACHED.

**Radiator cover**

- Remove the side fairings.
- Remove the fairing lug.
- Operating from both sides, unscrew and remove the fixing screws.

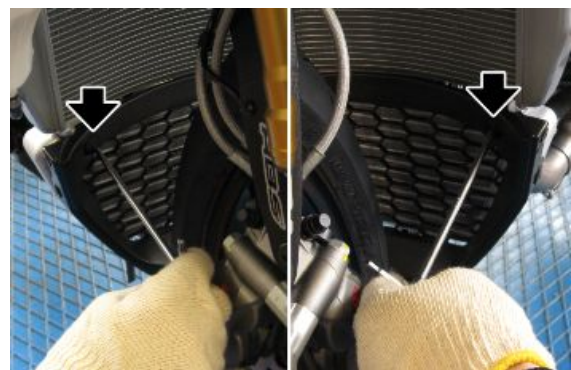

- Remove the radiator cover

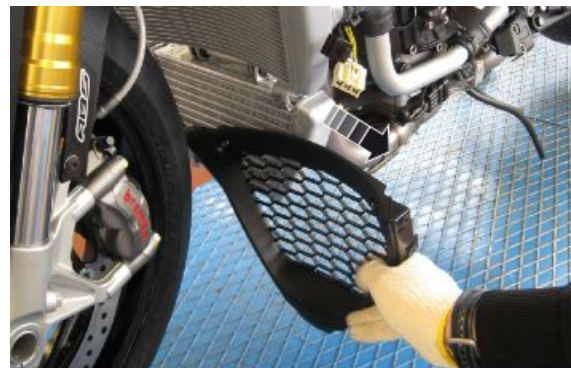
**Tail guard**

- Carry out the saddle removal procedure.
- Carry out the side fairing removal procedure.
- Undo and remove the six fixing screws (1).



- Remove the two plastic inserts (2) from both sides of the motorcycle.



- Unscrew and remove the screw (3).



- Unhook the saddle opening cable (4) from its seat.



- Remove the left (5) and right (6) tail fairing.

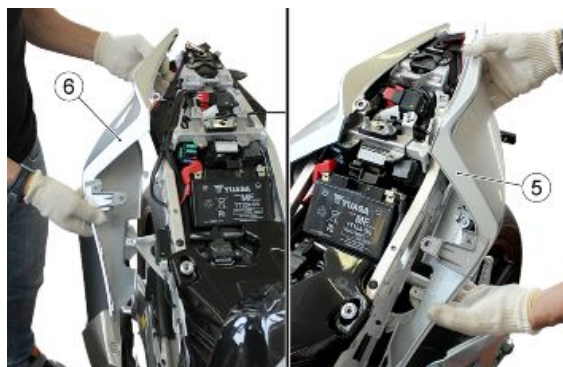

Side air deflectors

The following procedure is for a single lateral duct but is applicable to both.

- Remove the windshield.
- Unscrew and remove the two fixing nuts.



- Remove the duct from its seat on the frame.

CAUTION

DURING REASSEMBLY, THE DUCT MUST BE SEATED CORRECTLY ON THE FRAME TO ENSURE THAT IT IS FLUSH WITH THE ADJACENT PARTS.

See also

Headlight fairing

INDEX OF TOPICS

PRE-DELIVERY

PRE DE

Carry out the listed checks before delivering the motorcycle.

WARNING

HANDLE FUEL WITH CARE.

Aesthetic inspection

- Paintwork
 - Fitting of Plastic Parts
 - Scratches
 - Dirt
-

Tightening torques inspection

- Safety fasteners:
 - front and rear suspension unit
 - front and rear brake calliper retainer unit
 - front and rear wheel unit
 - engine - chassis retainers
 - steering assembly
 - Plastic parts fixing screws
-

Electrical system

- Main switch
- Headlamps: high beam lights, low beam lights, tail lights (front and rear) and their warning lights
- Headlight adjustment according to regulations in force
- Rear brake light push-button
- Turn indicators and their warning lights
- Instrument cluster
- Instrument panel warning lights
- Horn
- Electric starter
- Engine stop via emergency stop switch and side stand
- Through the diagnostic tool, check that the last mapping version is present in the control unit/s and, if required, program the control unit/s again: consult the technical service website to know about available upgrades and details regarding the operation.

CAUTION



TO ENSURE MAXIMUM PERFORMANCE, THE BATTERY MUST BE CHARGED BEFORE USE. INADEQUATE CHARGING OF THE BATTERY WITH A LOW LEVEL OF ELECTROLYTE BEFORE IT IS FIRST USED SHORTENS THE LIFE OF THE BATTERY.

CAUTION



WHEN INSTALLING THE BATTERY, ATTACH THE POSITIVE LEAD FIRST AND THEN THE NEGATIVE ONE, AND PERFORM THE REVERSE OPERATION DURING REMOVAL.

CAUTION



THE BATTERY ELECTROLYTE IS TOXIC, CORROSIVE AND AS IT CONTAINS SULPHURIC ACID, IT CAN CAUSE BURNS WHEN IN CONTACT WITH THE SKIN. WHEN HANDLING BATTERY ELECTROLYTE, WEAR TIGHT-FITTING GLOVES AND PROTECTIVE APPAREL. IN THE EVENT OF SKIN CONTACT WITH THE ELECTROLYTIC FLUID, RINSE WELL WITH PLENTY OF CLEAN WATER. IT IS PARTICULARLY IMPORTANT TO PROTECT YOUR EYES BECAUSE EVEN TINY AMOUNTS OF BATTERY ACID MAY CAUSE BLINDNESS. IF THE FLUID GETS IN CONTACT WITH YOUR EYES, WASH WITH ABUNDANT WATER FOR FIFTEEN MINUTES AND CONSULT AN EYE SPECIALIST IMMEDIATELY. THE BATTERY RELEASES EXPLOSIVE GASES; KEEP IT AWAY FROM FLAMES, SPARKS, CIGARETTES OR ANY OTHER HEAT SOURCES. ENSURE ADEQUATE VENTILATION WHEN SERVICING OR RECHARGING THE BATTERY. BATTERY LIQUID IS CORROSIVE. DO NOT POUR OR SPILL ON PLASTIC COMPONENTS IN PARTICULAR. ENSURE THAT THE ELECTROLYTIC ACID IS COMPATIBLE WITH THE BATTERY BEING ACTIVATED.

CAUTION



NEVER USE FUSES WITH A CAPACITY HIGHER THAN THAT RECOMMENDED. THE USE OF A FUSE OF UNSUITABLE CAPACITY MAY RESULT IN SERIOUS DAMAGES TO THE WHOLE VEHICLE OR EVEN CAUSE A FIRE.

Levels check

- Hydraulic braking system fluid level
- Clutch system fluid level
- Engine coolant level
- Engine oil level

Road test

- Cold start
- Instrument panel operation
- Response to throttle control
- Stability when accelerating and braking
- Front and rear brake efficiency
- Front and rear suspension efficiency

- Abnormal noise
-

Static test

Static control after the test drive:

- Restarting when warmed up
 - Idling
 - Uniform turning of the steering
 - Possible leaks
 - Radiator electric fans operation
-

Functional inspection

- Hydraulic braking system
 - Brake and clutch lever travel
 - Clutch - Check for correct operation
 - Engine - Check for correct general operation and absence of abnormal noise
 - Other
 - Documentation check:
 - Check the frame and engine numbers
- Check included tools (where applicable)
- Licence plate fitting
 - Locks checking
 - Tyre pressure check
 - Fitting of mirrors and possible accessories



NEVER EXCEED THE RECOMMENDED INFLATION PRESSURES SINCE THE TYRES MAY BURST.

CAUTION



CHECK AND ADJUST TYRE PRESSURE WITH TYRES AT AMBIENT TEMPERATURE.

Specific operations for the vehicle

- Remove the screw (2).
- Remove the plastic cover (1).



- Fit the rear pedal in its seat.
- Fit the two TCEI M8X45 screws and tighten with a torque wrench to a torque of 18 Nm (13.27 lbf ft)



NOTE

REPEAT THE STEPS TO FIT THE PASSENGER FOOTPEG ON THE OPPOSITE SIDE.

LICENSE PLATE HOLDER

- Set three washers of suitable diameter between license plate and its holder to avoid damaging the license plate.



WARNING

OPERATIONS REQUIRED TO RENDER VEHICLE COMPLIANT WITH TWO SEATER TYPE APPROVAL.

Sostituzione sella

- Insert the key in the lock and turn it clockwise.
- Remove the tail fairing.



- Fit the two-seater saddle.



Regolazione snodo degli specchietti retrovisori

- With the mirror closed (base turned 90° in relation to the mirror) check that the nut is closed properly, as indicated by the arrow, (you should be able to see about 0.5 mm - 1 mm (0.02 in - 0.04 in) of the threaded pin projecting from the nut and the Loctite 270).



If the nut is not closed correctly, proceed as follows:

- Close the mirror (base turned 90° in relation to the mirror).
- Remove the glass from the indicator light.



- Cut the wiring harness clamp (if there is one), disconnect the wiring harness connector and pull the wiring harness away from the mirror.



- Loosen the nut so its upper surface is about 0.5 mm (0.02 in) above the end of the threaded pin.
- Put some Loctite 270 inside the nut.



- Screw the nut back down until its upper surface is about 0.5 mm - 1 mm (0.02 in - 0.04 in) away from the end of the pin.
- Wait 24 hours for the Loctite to dry well before moving the mirror.

- Assemble the rear-view mirror.
- Pass the wiring harness through the specific hole and place the rear-view mirror in its seat.



- Tighten the two fixing nuts of the rear-view mirror.



- Connect the connector.

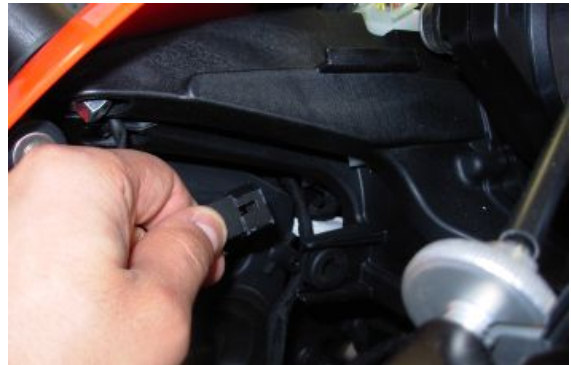

A

a-PRC setting buttons: 220
ABS: 232, 465, 474
Air filter: 73
Air temperature sensor: 163
Aprilia V4-MP Technology: 243

B

Battery: 133, 146
Brake: 486–488, 490, 491, 495, 496
Brake calliper: 486, 487
Brake disc: 487, 488
Brake pads: 490, 491
Brake pump: 495, 496
Bulbs:
Bushings:

C

CAN line: 233
Catalytic converter: 459
Chain: 13, 447, 453
Clutch: 201, 273, 291–293, 296–298, 304, 348
Coil: 183
Connecting rods: 355, 359, 368
Connectors: 225
coolant: 501, 503, 506
Coolant: 501, 503, 506
Countershaft: 347, 349, 353, 358
Crankcase: 345, 353, 357, 370
Crankshaft: 356, 358, 366
Cylinder: 75, 81

D

Desmodromic drum: 278
Diagnostics: 474
Drive chain: 13, 447

E

ECU: 226, 475
Electric fan: 205, 500
Electrical system: 13, 91, 95, 549
Engine oil: 70, 462
Engine temperature sensor: 161
Exhaust: 209, 456, 460, 461
Exhaust manifold: 460

F

Fairings: 529
Filter box:
Fork: 395, 399, 403, 408
Forks: 278

Front cylinder head valves: 75
Front head: 309, 315, 318, 319, 340, 353, 355
Front wheel: 391, 392, 489
Fuel: 181, 384, 539
Fuel pump: 181, 384
Fuses: 137

H

Handlebar: 394
Head cover: 308
Headlight: 522, 523, 547

I

Identification: 11
Instrument panel: 521, 542
Intake pressure sensor: 156

K

Keys: 130

L

License plate holder: 533
Linkages: 435

M

Magneto flywheel: 288, 353
Maintenance: 8, 64, 67, 485
Maintenance Table: 67
Mirrors: 520
Mudguard: 538, 541

O

Oil filter: 73
Oil pressure sensor: 199
Oil sump: 353, 379
One-way valve: 382

P

Pistons: 355, 359, 368
Primary shaft: 277

R

Radiator: 504, 545
Rear cylinder head valves: 81
Rear head: 324, 331, 334, 335, 341, 353, 355
Rear wheel: 423, 426, 453, 488
Recommended products: 69
Ride by wire: 386
Run/Stop switch: 208

S

Saddle:
SAS valve actuator: 206
Scheduled maintenance: 64
Secondary air system:

Secondary shaft: 278
Shock absorber:
Shock absorbers: 431
Side fairings: 529
Side stand: 203, 455
Side stand sensor: 203
Spark plug: 69
Speed sensor: 148
Stand: 203, 454, 455
Start-up: 136, 285
Starter motor: 284
Steering damper: 416
Stepper motor: 389

T

Tank: 539
Throttle body: 186, 388, 389
Top fairing:
Track: 67
Transmission: 12, 351, 353
Tyres: 15

U

Use: 67, 474

W

Water pump: 353, 374, 502
Wiring diagram: 125