

aprilia

SERVICE STATION MANUAL

895777



RSV4 R



SERVICE STATION MANUAL

RSV4 R

THE VALUE OF SERVICE

Due to the continuous technical updates and specific mechanic training programs for aprilia products, only **aprilia Official Network** mechanics know this vehicle fully and have the special tools necessary to carry out maintenance and repair operations correctly.

The reliability of the vehicle also depends on its mechanical state. Checking the vehicle before riding, its regular maintenance and using only **Original aprilia Spare Parts** are essential!

For information about the nearest **Official Dealer and/or Service Centre**, consult the Yellow Pages or search directly from the map on our Official Website:

www.aprilia.com

Only by requesting aprilia Original Spare Parts can you be sure of purchasing products that were developed and tested together with the actual vehicle itself. All aprilia Original Spare Parts undergo quality control procedures to guarantee reliability and durability.

The descriptions and illustrations given in this publication are not binding; While the basic characteristics as described and illustrated in this booklet remain unchanged, aprilia reserves the right, at any time and without being required to update this publication beforehand, to make any changes to components, parts or accessories, which it considers necessary to improve the product or which are required for manufacturing or construction reasons.

Not all versions/models shown in this publication are available in all Countries. The availability of individual versions/models should be confirmed with the official aprilia sales network.

© Copyright 2009 **aprilia**. All rights reserved. Reproduction of this publication in whole or in part is prohibited. **aprilia** - After-sales service.

Aprilia trademark is property of Piaggio & C. S.p.A.

SERVICE STATION MANUAL

RSV4 R

- This manual provides the main information to carry out regular maintenance operations on your vehicle.
- This manual is intended to aprilia Dealers and their qualified mechanics; several concepts have been deliberately omitted as they are considered unnecessary. As it is not possible to include complete mechanical notions in this manual, users should have basic mechanical knowledge or minimum knowledge about the procedures involved when repairing scooters. Without this knowledge, repairing or checking the vehicle may be inefficient or even dangerous. As the vehicle repair and check procedures are not described in detail, be extremely cautious so as not to damage components or injure individuals. In order to optimise customer satisfaction when using our vehicles, aprilia s.p.a. commits itself to continually improve its products and the relative documentation. The main technical modifications and changes in repair procedures are communicated to all aprilia Sales Outlets and its International Subsidiaries. These changes will be introduced in the subsequent editions of the manual. In case of need or further queries on repair and check procedures, consult aprilia CUSTOMER DEPARTMENT, which will be prepared to provide any information on the subject and any further communications on updates and technical changes related to the vehicle.

NOTE Provides key information to make the procedure easier to understand and carry out.

CAUTION Refers to specific procedures to carry out for preventing damages to the vehicle.

WARNING Refers to specific procedures to carry out to prevent injuries to the repairer.



Personal safety Failure to completely observe these instructions will result in serious risk of personal injury.



Safeguarding the environment Sections marked with this symbol indicate the correct use of the vehicle to prevent damaging the environment.



Vehicle intactness The incomplete or non-observance of these regulations leads to the risk of serious damage to the vehicle and sometimes even the invalidity of the guarantee



INDEX OF TOPICS

CHARACTERISTICS

CHAR

SPECIAL TOOLS

S-TOOLS

MAINTENANCE

MAIN

TROUBLESHOOTING

TROUBL

ELECTRICAL SYSTEM

ELE SYS

ENGINE FROM VEHICLE

ENG VE

ENGINE

ENG

POWER SUPPLY

P SUPP

SUSPENSIONS

SUSP

CHASSIS

CHAS

BRAKING SYSTEM

BRAK SYS

COOLING SYSTEM

COOL SYS

BODYWORK

BODYW

PRE-DELIVERY

PRE DE

INDEX OF TOPICS

CHARACTERISTICS

CHAR

Rules

Safety rules

Carbon monoxide

If you need to keep the engine running while working on the vehicle, please ensure that you do so in an open or very well ventilated area. Never run the engine in an enclosed area. If you do work in an enclosed area, make sure to use a fume extraction system.

CAUTION



EXHAUST EMISSIONS CONTAIN CARBON MONOXIDE, A POISONOUS GAS WHICH CAN CAUSE LOSS OF CONSCIOUSNESS AND EVEN DEATH.

Fuel

CAUTION



THE FUEL USED TO POWER INTERNAL COMBUSTION ENGINES IS HIGHLY FLAMMABLE AND MAY BE EXPLOSIVE UNDER CERTAIN CONDITIONS. IT IS THEREFORE RECOMMENDED TO CARRY OUT REFUELLING AND MAINTENANCE PROCEDURES IN A VENTILATED AREA WITH THE ENGINE SWITCHED OFF. DO NOT SMOKE DURING REFUELLING AND NEAR FUEL VAPOURS, AVOIDING ANY CONTACT WITH NAKED FLAMES, SPARKS OR OTHER SOURCES WHICH MAY CAUSE THEM TO IGNITE OR EXPLODE. DO NOT DISPERSE FUEL IN THE ENVIRONMENT. KEEP OUT OF THE REACH OF CHILDREN

Hot components

The engine and the exhaust system components become very hot and remain hot for some time after the engine has been switched off. When handling these components, wear insulating gloves or wait until the engine and the exhaust system have cooled down.

Coolant

The coolant contains ethylene glycol which, under certain conditions, can become flammable.

When it burns, ethylene glycol produces an invisible flame which however can cause burns.

CAUTION



TAKE CARE NOT TO POUR COOLANT ONTO HOT ENGINE OR EXHAUST SYSTEM COMPONENTS; THE FLUID MAY CATCH FIRE AND BURN WITH INVISIBLE FLAMES. WHEN CARRYING OUT MAINTENANCE OPERATIONS, IT IS ADVISABLE TO WEAR LATEX GLOVES. EVEN THOUGH IT IS TOXIC, COOLANT HAS A SWEET FLAVOUR WHICH MAKES IT VERY ATTRACTIVE TO ANIMALS. NEVER LEAVE THE COOLANT IN OPEN CONTAINERS IN AREAS ACCESSIBLE TO ANIMALS AS THEY MAY DRINK IT.

**KEEP OUT OF THE REACH OF CHILDREN
DO NOT REMOVE THE RADIATOR CAP WHEN THE ENGINE IS STILL HOT. THE COOLANT IS UNDER PRESSURE AND MAY CAUSE BURNS.**

Used engine oil and transmission oil

CAUTION



IT IS ADVISABLE TO WEAR PROTECTIVE IMPERMEABLE GLOVES WHEN SERVICING THE VEHICLE.

THE ENGINE OR GEARBOX OIL MAY CAUSE SERIOUS INJURIES TO THE SKIN IF HANDLED FOR PROLONGED PERIODS OF TIME AND ON A REGULAR BASIS.

WASH YOUR HANDS CAREFULLY AFTER HANDLING OIL.

HAND THE OIL OVER TO OR HAVE IT COLLECTED BY THE NEAREST USED OIL RECYCLING COMPANY OR THE SUPPLIER.

DO NOT DISPOSE OF OIL IN THE ENVIRONMENT

KEEP OUT OF THE REACH OF CHILDREN



THE BRAKE FLUID MAY DAMAGE PAINTED, PVC OR RUBBER SURFACES. WHEN SERVICING THE BRAKING SYSTEM, PROTECT THESE COMPONENTS WITH A CLEAN CLOTH. ALWAYS WEAR PROTECTIVE GOGGLES WHEN SERVICING THE BRAKING SYSTEM. THE BRAKE FLUID IS EXTREMELY DANGEROUS TO THE EYES. IN THE EVENT OF ACCIDENTAL CONTACT WITH THE EYES, RINSE THEM IMMEDIATELY WITH PLENTY OF COLD, CLEAN WATER AND SEEK MEDICAL ADVICE.

KEEP OUT OF THE REACH OF CHILDREN.

Battery electrolyte and hydrogen gas

CAUTION



THE BATTERY ELECTROLYTE IS TOXIC, CORROSIVE AND AS IT CONTAINS SULPHURIC ACID, IT CAN CAUSE BURNS WHEN IN CONTACT WITH THE SKIN. WHEN HANDLING BATTERY ELECTROLYTE, WEAR TIGHT-FITTING GLOVES AND PROTECTIVE APPAREL. IN THE EVENT OF SKIN CONTACT WITH THE ELECTROLYTIC FLUID, RINSE WELL WITH PLENTY OF CLEAN WATER. IT IS PARTICULARLY IMPORTANT TO PROTECT YOUR EYES BECAUSE EVEN TINY AMOUNTS OF BATTERY ACID MAY CAUSE BLINDNESS. IF THE FLUID GETS IN CONTACT WITH YOUR EYES, WASH WITH ABUNDANT WATER FOR FIFTEEN MINUTES AND CONSULT AN EYE SPECIALIST IMMEDIATELY. THE BATTERY RELEASES EXPLOSIVE GASES; KEEP IT AWAY FROM FLAMES, SPARKS, CIGARETTES OR ANY OTHER HEAT SOURCES. ENSURE ADEQUATE VENTILATION WHEN SERVICING OR RECHARGING THE BATTERY.

KEEP OUT OF THE REACH OF CHILDREN.

BATTERY LIQUID IS CORROSIVE. DO NOT POUR IT OR SPILL IT, PARTICULARLY ON PLASTIC COMPONENTS. ENSURE THAT THE ELECTROLYTIC ACID IS COMPATIBLE WITH THE BATTERY TO BE ACTIVATED.

Maintenance rules

GENERAL PRECAUTIONS AND INFORMATION

When repairing, dismantling and reassembling the vehicle follow the recommendations reported below carefully.

BEFORE REMOVING COMPONENTS

- Before dismantling components, remove dirt, mud, dust and foreign bodies from the vehicle. Use the special tools designed for this bike, as required.

COMPONENTS REMOVAL

- Do not loosen and/or tighten screws and nuts using pliers or any other tools than the specific wrench.
- Mark the positions on all connection joints (pipes, cables, etc.) before separating them, and identify them with different distinctive symbols.
- Each component needs to be clearly marked to enable identification during reassembly.
- Clean and wash the dismantled components carefully using a low-flammability detergent.
- Keep mated parts together since they have "adjusted" to each other due to normal wear.
- Some components must be used together or replaced altogether.
- Keep away from heat sources.

REASSEMBLY OF COMPONENTS

CAUTION

BEARINGS MUST BE ABLE TO ROTATE FREELY, WITHOUT JAMMING AND/OR NOISE: OTHERWISE, THEY NEED TO BE REPLACED.

- Only use ORIGINAL Aprilia SPARE PARTS.
- Comply with lubricant and consumables use guidelines.
- Lubricate parts (whenever possible) before reassembling them.
- When tightening nuts and screws, start either from the components with the largest diameter or from the innermost components, proceeding diagonally. Tighten nuts and screws in successive steps before applying the tightening torque.
- Always replace self-locking nuts, washers, sealing rings, circlips, O-rings (OR), cotter pins and screws with new parts if the thread is damaged.
- When assembling the bearings, make sure to lubricate them well.
- Check that each component is assembled correctly.
- After a repair or routine maintenance, carry out pre-ride checks and test the vehicle on private grounds or in an area with low traffic.
- Clean all mating surfaces, oil seal rims and gaskets before refitting. Smear a thin layer of lithium-based grease on the oil seal rims. Reassemble oil seals and bearings with the brand or batch number facing outward (visible side).

ELECTRIC CONNECTORS

Electric connectors must be disconnected as described below; failure to comply with this procedure causes irreparable damage to both the connector and the cable harness:

Press the relevant safety hooks, if any.

- Grip the two connectors and disconnect them by pulling them in opposite directions.

- If any signs of dirt, rust, moisture, etc. are noted, clean the inside of the connector carefully with a jet of compressed air.
- Ensure that the cables are correctly fastened to the internal connector terminals.
- Then connect the two connectors, ensuring that they couple correctly (if fitted with clips, you will hear them "click" into place).

CAUTION

TO DISCONNECT THE TWO CONNECTORS, DO NOT PULL THE CABLES.

NOTE

THE TWO CONNECTORS CONNECT ONLY FROM ONE SIDE: CONNECT THEM THE RIGHT WAY ROUND.

TIGHTENING TORQUES**CAUTION**

DO NOT FORGET THAT THE TIGHTENING TORQUES OF ALL FASTENING ELEMENTS ON WHEELS, BRAKES, WHEEL BOLTS AND ANY OTHER SUSPENSION COMPONENTS PLAY A KEY ROLE IN ENSURING VEHICLE SAFETY AND MUST COMPLY WITH SPECIFIED VALUES. CHECK THE TIGHTENING TORQUES OF FASTENING PARTS ON A REGULAR BASIS AND ALWAYS USE A TORQUE WRENCH TO REASSEMBLE THESE COMPONENTS. FAILURE TO COMPLY WITH THESE RECOMMENDATIONS MAY CAUSE ONE OF THESE COMPONENTS TO GET LOOSE AND EVEN DETACHED, THUS BLOCKING A WHEEL, OR OTHERWISE COMPROMISE VEHICLE HANDLING. THIS CAN LEAD TO FALLS, WITH THE RISK OF SERIOUS INJURY OR DEATH.

Running-in

Running the engine in correctly is essential for ensuring engine longevity and functionality. Twisty roads and gradients are ideal for running in the engine, brakes and suspension effectively. Vary your riding speed during the running in period. This ensures that components operate in "loaded" conditions and then "unloaded" conditions, allowing the engine components to cool.

CAUTION

THE FULL PERFORMANCE OF THE VEHICLE IS ONLY AVAILABLE AFTER THE SERVICE AT THE END OF THE RUNNING IN PERIOD.

Follow the guidelines detailed below:

- Do not twist the throttle grip abruptly and completely when the engine is working at a low revs, either during or after run-in.
- During the first 100 Km (62 miles) use the brakes gently, avoiding sudden or prolonged braking. That is to permit the adequate adjustment of the pad friction material to the brake discs.
- It is recommended, during the first 1000 km (621 mi), not to exceed 7500 rpm and 9500 rpm up 2000 km (1243 mi).



AFTER THE SPECIFIED MILEAGE, TAKE YOUR VEHICLE TO AN Official Aprilia Dealer FOR THE CHECKS INDICATED IN THE "PERIODICAL MAINTENANCE" TABLE IN THE SCHEDULED MAINTENANCE SECTION TO AVOID INJURING YOURSELF, OTHERS AND /OR DAMAGING THE VEHICLE.

Vehicle identification

SERIAL NUMBER LOCATION

These numbers are necessary for vehicle registration.

NOTE

ALTERING IDENTIFICATION NUMBERS MAY BE SERIOUSLY PUNISHABLE BY LAW. IN PARTICULAR, MODIFYING THE FRAME NUMBER IMMEDIATELY VOIDS THE WARRANTY.

This number consists of numbers and letters, as in the example shown below.

ZD4RKA000YSXXXXXX

KEY:

ZD4: WMI (World manufacturer identifier) code;

RK: model;

A00: version variation;

0: free digit

Y year of manufacture

S: production plant (S= Scorzè);

XXXXXX: serial number (6 digits);

CHASSIS NUMBER

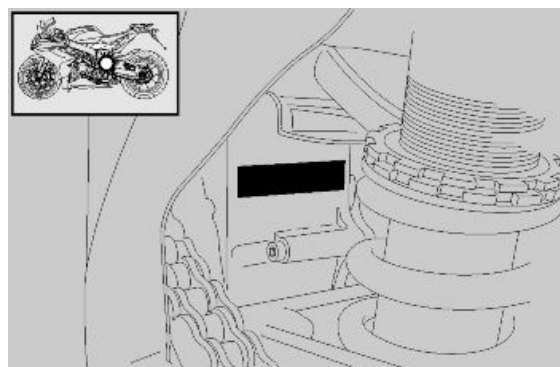
The chassis number is stamped on the right side of the headstock.



ENGINE NUMBER

The engine number is printed on the base of the engine crankcase, left hand side.

Engine No.



Dimensions and mass

WEIGHT AND DIMENSIONS

Specification	Desc./Quantity
Max. length	2040 mm (80.31 in)
Max. width (at handlebar)	735 mm (28.94 in)
Max. height (to windshield)	1120 mm (44.09 in)
Saddle height	847 mm (33.35 in)
Wheelbase	1420 mm (55.90 in)
Minimum ground clearance	130 mm (5.12 in)
Kerb weight	194 kg (428 lb)
Kerb weight	205 kg (452 lb)

Specification	Desc./Quantity
Full loaded weight (rider only)	280 kg (617 lb)

Engine

ENGINE

Specification	Desc./Quantity
Model	V4
Type	65° longitudinal V-4, 4-stroke, 4 valves per cylinder, double overhead camshafts.
Engine capacity	999 cm ³ (60.96 cu.in)
Bore / stroke	78 mm / 52.26 mm (3.07 in / 2.06 in)
Compression ratio	13 : 1
Engine idle speed	1400 ± 100 rpm
Engine revs at maximum speed	14000 ± 100 rpm
Clutch	Multiplate wet clutch with mechanical control lever on left side of the handlebar Anti-juddering and slipper clutch systems
Electric	Electric starter
Timing system	Morse chain on intake camshaft, cam to cam gear, bucket tappets and valve clearance adjustments with calibrated pads
Acceptable values with control clearance between cam and valve	Intake: 0.10 - 0.15 mm (0.0039 - 0.0059 in) exhaust: 0.20 - 0.25 mm (0.0079 - 0.0098 in)
Lubrication	Wet sump with oil radiator
Oil pump	Dual trochoidal pump (lubrication + cooling)
Oil filter	With external cartridge filter
Cooling	Fluid
Cooling system	3-way thermostatic valve, cooling radiator with electric fan and expansion tank
Coolant pump	Centrifugal bearingless aspirating pump with integrated ceramic gasket
Air filter	In cotton
Alternatively:	
Air filter	Paper

Transmission

GEAR RATIOS

Specification	Desc./Quantity
Primary drive ratio	44 / 73 (with gears)
1st gear ratio	15 / 39 (secondary)
2nd gear ratio	16 / 33 (secondary)
3rd gear ratio	20 / 34 (secondary)
4th gear ratio	22 / 32 (secondary)
5th gear ratio	26 / 34 (secondary)
6th gear ratio	27 / 33 (secondary)
Final drive gear ratio	16 / 40
Alternatively:	
Final drive ratio (to couple with the 110 link chain)	16 / 42

Capacities

CAPACITY

Specification	Desc./Quantity
Fuel capacity (reserve included)	17 l (3.74 UK gal)
Fuel tank reserve	3.6 l (0.79 UK gal)
Engine oil	oil and filter change 4 l (0.88 UK gal)
Coolant	2.7 l (0.59 UK gal)
Seats	1 + 1

Specification	Desc./Quantity
Maximum weight capacity	Two seat configuration: if vehicle is fitted with footrests and saddle for passenger 201 kg (443 lb)

Drive chain

DRIVE CHAIN

Specification	Desc./Quantity
Type	525 With sealed master link
Model	Regina 108 links
Alternatively:	
Model (to couple with 42 teeth sprocket)	Regina 110 links

Electrical system

ELECTRICAL SYSTEM

Specification	Desc./Quantity
Spark plugs	NGK-R CR9EKB Alternatively: NGK-R CR9EB NGK-R CR10E (for competition use)
Electrode gap	0.7 - 0.8 mm (0.027 - 0.031 in)
Battery	YUASA YTZ10S, 12 V 8.6 Ah alternatively YUASA YT12A-BS, 12 V 9.5 Ah
Coils	Stick coil
Recharging system	Flywheel with rare earth magnets
Generator	450 W
Main fuses	30 A
Auxiliary fuses	5A - 7.5A - 15A

BULBS

Specification	Desc./Quantity
Low-/ high beam light	12V - 55W H11
Front daylight running lights	12V - 5W
Turn indicators	12V - 10W (White light)
Licence plate light	12V - 5W

WARNING LIGHTS

Specification	Desc./Quantity
High beam light	LED
Right turn indicator	LED
Left turn indicator	LED
General warning	LED
Gear in neutral	LED
Side stand down	LED
Fuel reserve	LED
ABS	NOT ENABLED

Frame and suspensions

CHASSIS

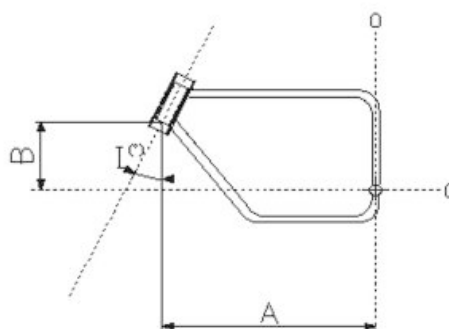
Specification	Desc./Quantity
Type	Aluminium, dual beam chassis with pressed and cast sheet elements.
Steering rake	26.5° (measurements with reference to bare frame)
Trail	107 mm (4.21 in)

SUSPENSION

Specification	Desc./Quantity
Front fork	Showa upside-down stanchions with adjustable hydraulic damping and 43 mm (1.69 in) diam. stanchions
Front wheel travel	120 mm (4.72 in)
Rear shock absorber	Sachs piggyback shock absorber with progressive APS system and adjustable spring preload, wheelbase and hydraulic compression and rebound damping
Rear wheel travel	130 mm (5.12 in)

SIZES A AND B

Specification	Desc./Quantity
Size "A"	639.5 mm (25.18 in) (measurements refer to the bare chassis)
Size "B"	329.5 mm (12.97 in) (measurements refer to the bare chassis)



Brakes

BRAKES

Specification	Desc./Quantity
Front	Dual 320 mm (12.59 inches) diam. floating disc, single block calipers with radial fixing and four pistons 34 mm diam. (1.34 inches) and 2 pads - radial pump and brake pipe in metal braid.
Rear	disc type -220 mm diam. (8.66 inches), 2-piston callipers - 32 mm diam. (1.25 inches) - pump with built-in tank and metal braid pipe.

Wheels and tyres

CERCHI RUOTE

Specification	Desc./Quantity
Front wheel rim	3.50 x 17"
Rear wheel rim	6.00 x 17"

TYRES

Specification	Desc./Quantity
Tyre model	Pirelli DIABLO Super Corsa SP Metzeler RACETEC K3 Michelin Power One Dunlop SPORTMAX GP Racer (Mixture "M" Front) Dunlop SPORTMAX GP Racer (Mixture "E" Rear)
Front tyre	120/70 ZR17 (58W)
Inflation pressure	1 passenger: 2.3 bar (230 kPa) (33.36 PSI) 2 passengers: 2.5 bar (250 kPa) (36.26 PSI)
Rear tyre	190/55 ZR17 (75W)

Specification	Desc./Quantity
Inflation pressure	190/50 ZR17 (73W) 1 passenger: 2.5 bar (250 kPa) (36.26 PSI) 2 passengers: 2.8 bar (280 kPa) (40.61 PSI)

Supply

FUEL SYSTEM

Specification	Desc./Quantity
Fuel	Premium unleaded petrol, minimum octane rating 95 (NORM) and 85 (NOMM)

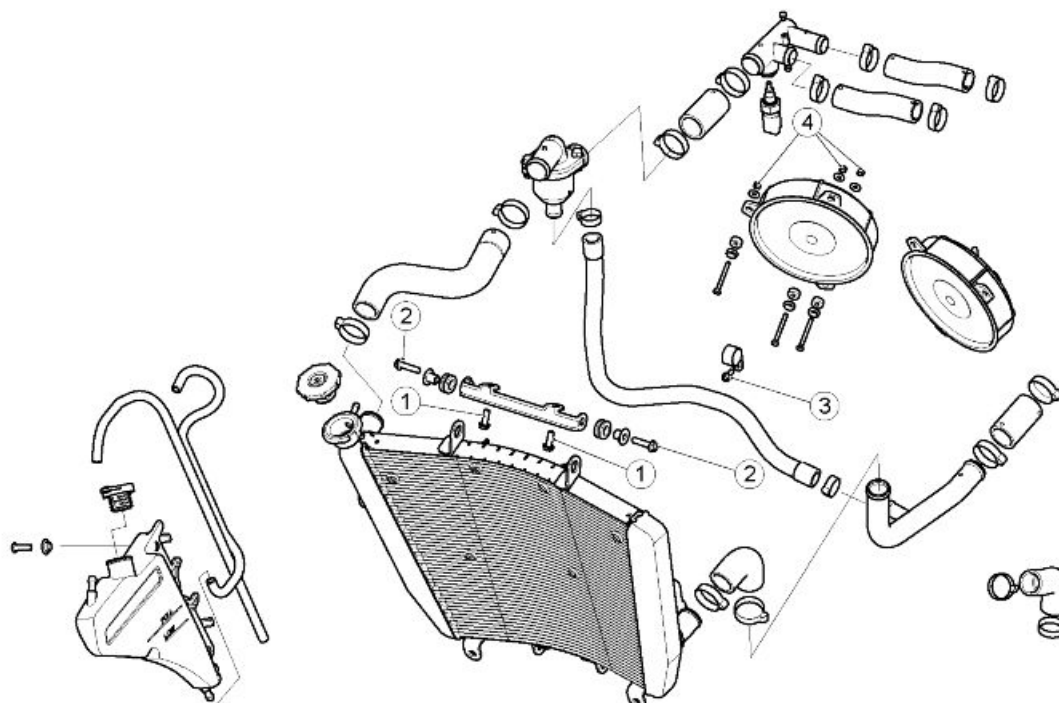
FUEL SYSTEM

Specification	Desc./Quantity
Throttle body diameter	48 mm (1.89 in)
Type	Electronic injection with 2 injectors per cylinder, 4 throttle bodies motorised (Ride by wire). 2 dynamic air intakes. Selectable multimap.

Tightening Torques

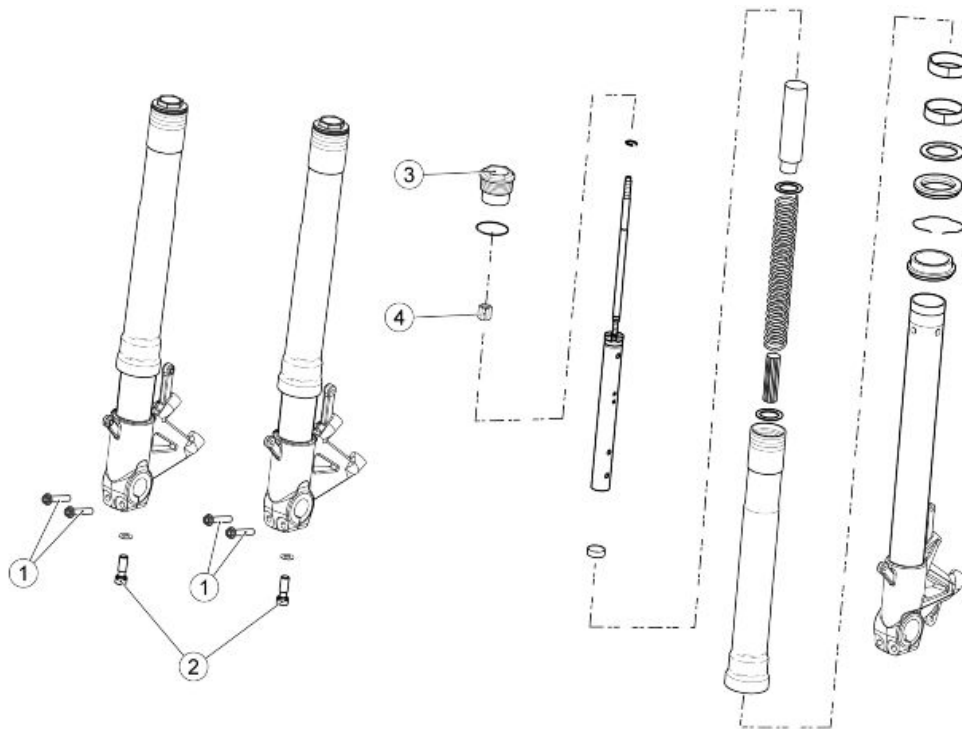
Chassis

Front side



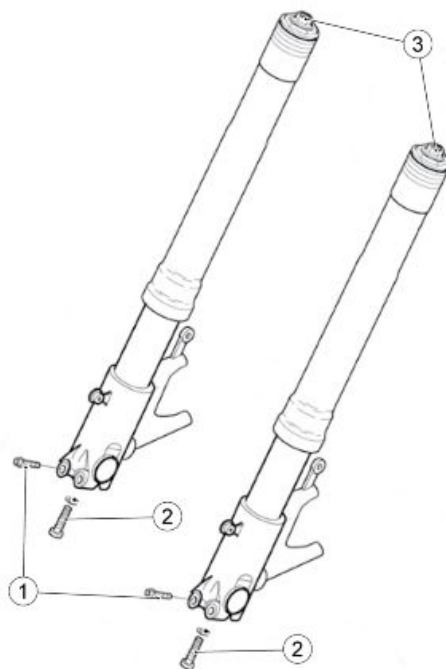
OIL RADIATOR

pos.	Description	Type	Quantity	Torque	Notes
1	Screws fastening oil radiator to mounting bracket	M6	1	7 Nm (5.16 lbf ft)	-



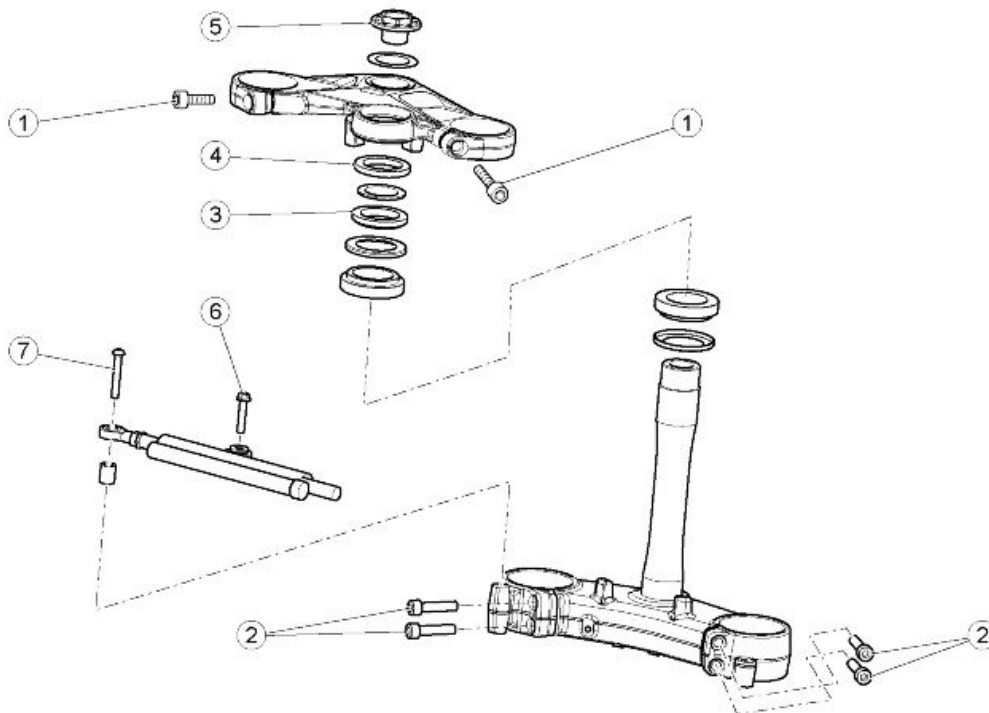
FRONT FORK - SACHS

pos.	Description	Type	Quantity	Torque	Notes
1	TEFL screw (fasten onto Fork Hubs)	M6x40	4	10 Nm (7.37 lb ft)	-
2	Screw (Piston fixing to the stem base)	-	2	30 Nm (22.13 lb ft)	-
3	Upper cover	-	2	20 Nm (14.75 lb ft)	-
4	Upper cover locking nut	-	2	20 Nm (14.75 lb ft)	-
-	Speed sensor bracket screw	M5x12	1	0.6 Nm (0.44 lb ft)	-



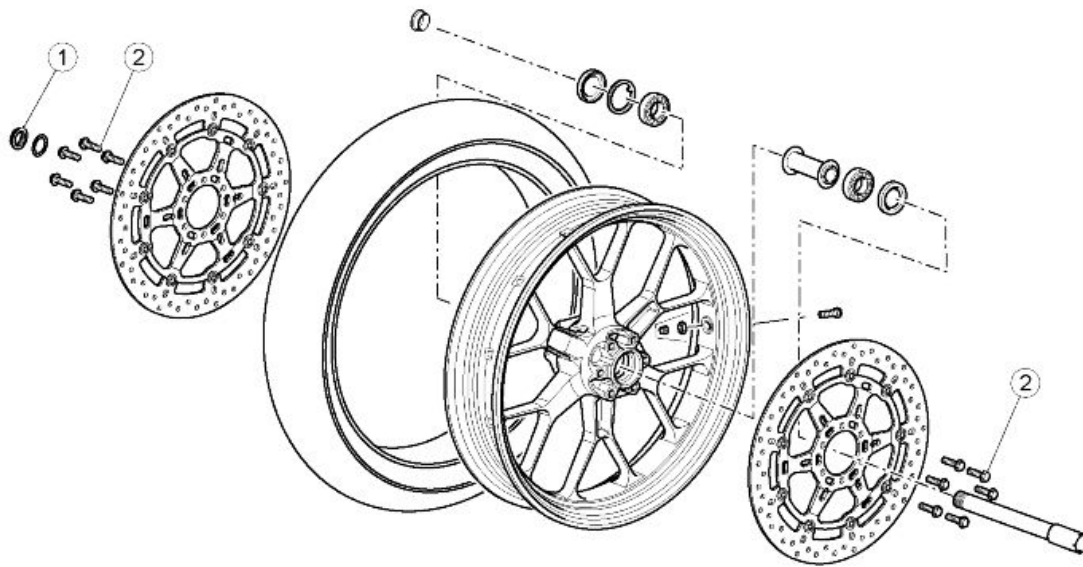
FRONT FORK - SHOWA

pos.	Description	Type	Quantity	Torque	Notes
1	Calliper mounting bracket fixing screws	M8	2+2	22 Nm (16.23 lbf ft)	-
2	Pumping member fixing screw	-	1+1	30 - 39 Nm (22.13 - 28.76 lbf ft)	-
3	Sleeve top cap	-	1+1	30 - 39 Nm (22.13 - 28.76 lbf ft)	-
-	Speed sensor bracket screws	-	1	-	-



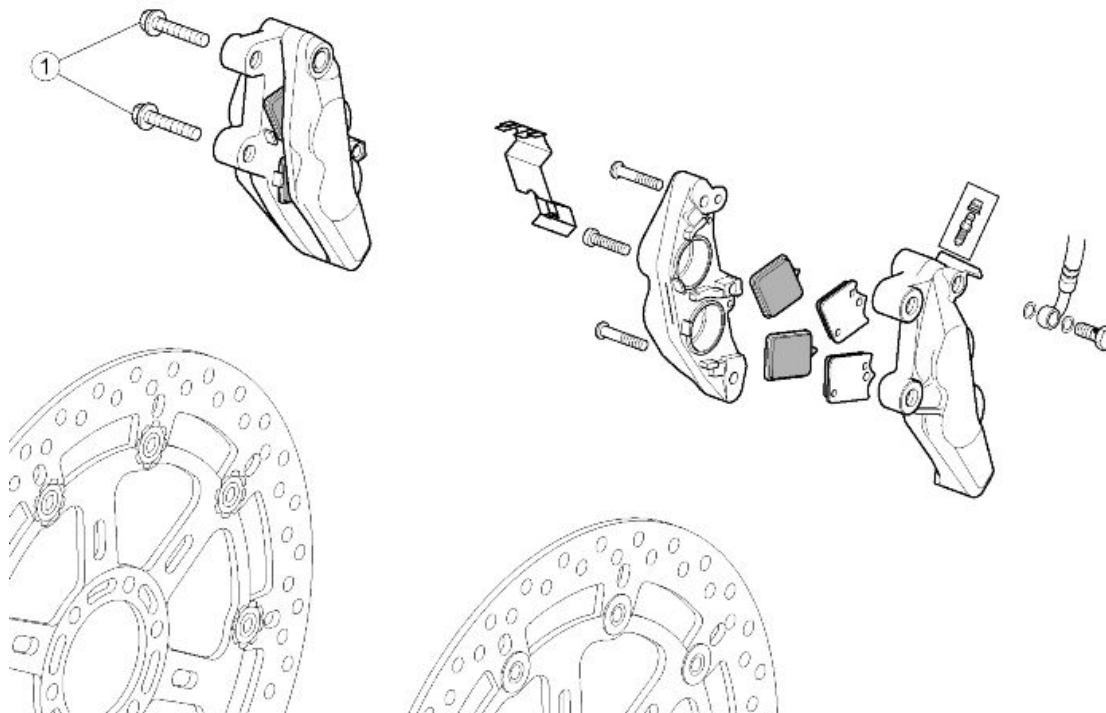
STEERING

pos.	Description	Type	Quantity	Torque	Notes
1	Screws fastening upper yoke to stanchions	M8	2	25 Nm (18.44 lb ft)	-
2	Screws fastening lower yoke to stanchions	M8	4	25 Nm (18.44 lb ft)	-
3	Headstock lock ring	M35x1	1	35 ± 5 Nm (25.81 ± 3.69 lb ft)	Bend the tabs into the notches in the lock ring
4	Headstock counter-lock ring	M35x1	1	Manual +35°	Bend the tabs into the notches in the lock ring
5	Upper yoke fixing cap	-	1	100 Nm (73.76 lb ft)	-
6	Screw fastening shock absorber to frame	M6	1	10 Nm (7.37 lb ft)	-
7	Screw fastening shock absorber to lower yoke	M6	1	10 Nm (7.37 lb ft)	-



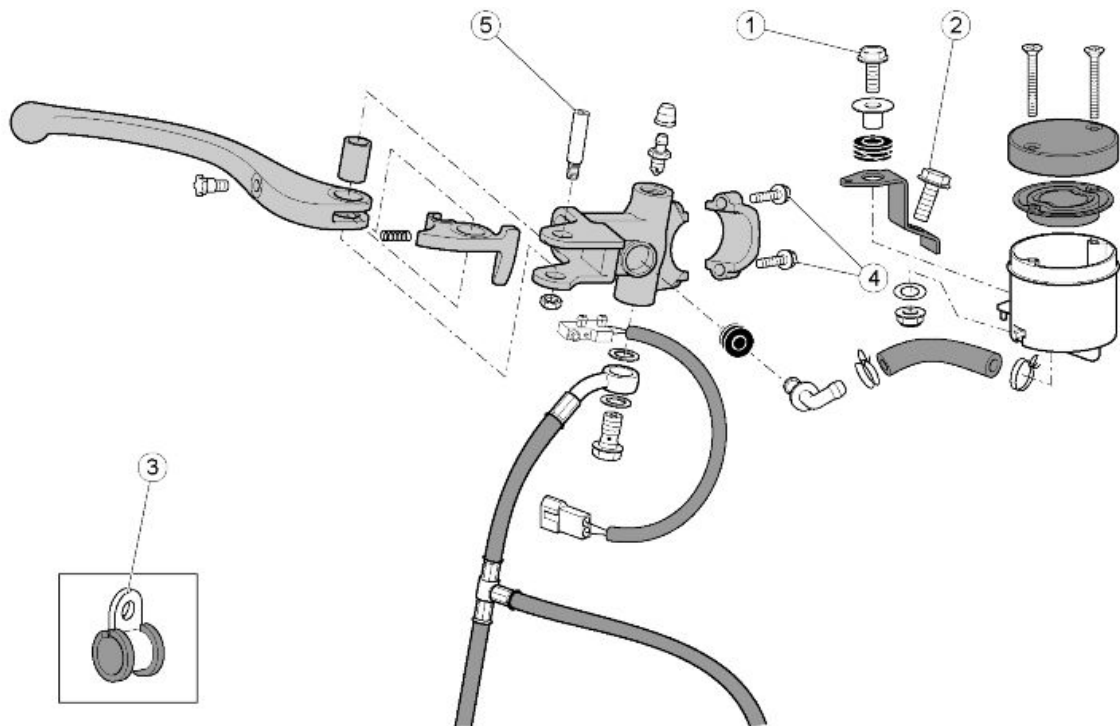
FRONT WHEEL

pos.	Description	Type	Quantity	Torque	Notes
1	Front wheel spindle nut	M25x1.5	1	80 Nm (59 lb ft)	-
2	Front brake disc fixing screws	M8	6 + 6	30 Nm (22.13 lb ft)	Loct. 243



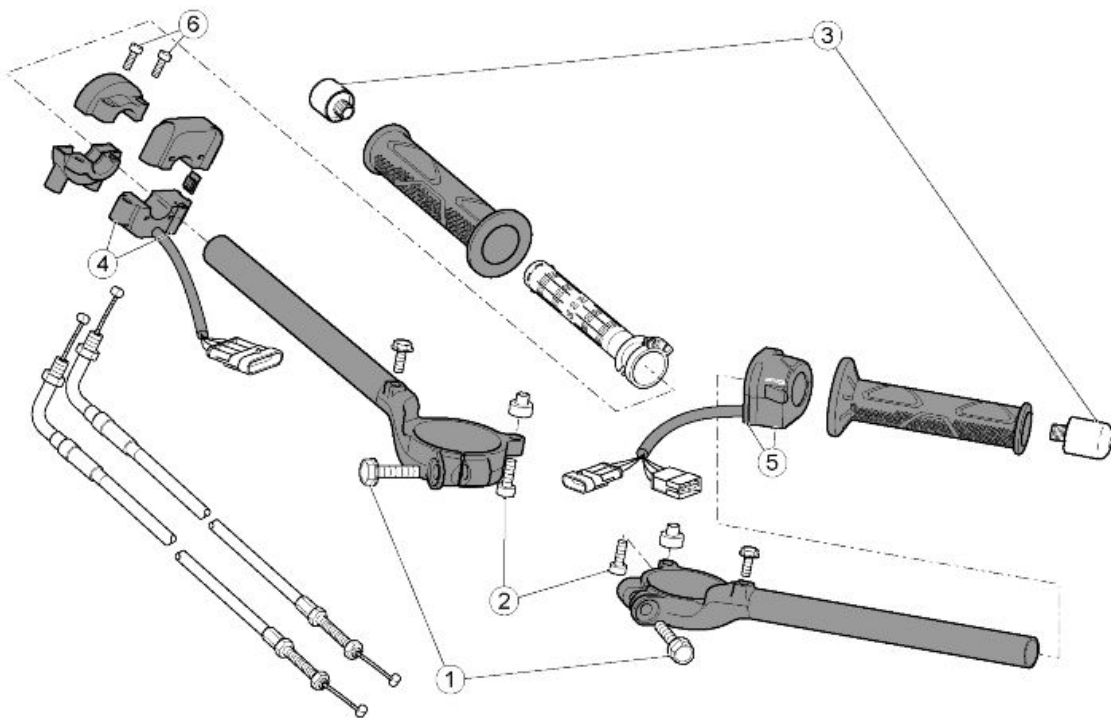
FRONT BRAKE CALLIPER

pos.	Description	Type	Quantity	Torque	Notes
1	Front brake calliper fixing screws	M10x1.25	2 + 2	50 Nm (36.88 lb ft)	-



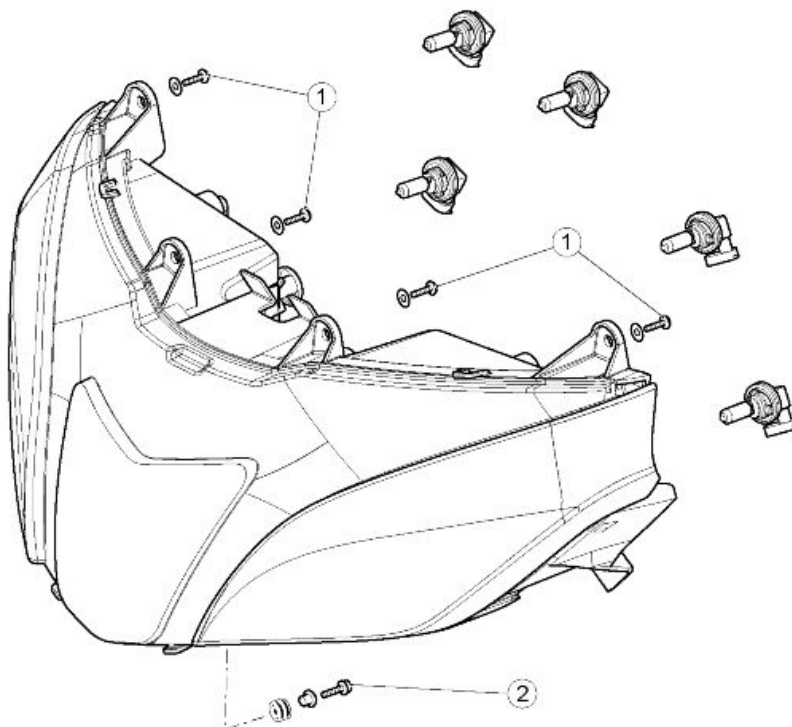
FRONT BRAKE PUMP

pos.	Description	Type	Quantity	Torque	Notes
1	Screw fastening front brake fluid reservoir to bracket	M6	1	7 Nm (5.16 lbf ft)	-
2	Screw fastening brake fluid reservoir mounting bracket to handlebar	M6	1	7 Nm (5.16 lbf ft)	-
3	Screw fastening brake pipe grommet to the lower yoke	M5	1	8 Nm (5.9 lbf ft)	-
4	Front brake pump U bolt clamp	M6	2	10 Nm (7.37 lbf ft)	-
5	Front brake lever pin fixing screw	M6	1	10 Nm (7.37 lbf ft)	-



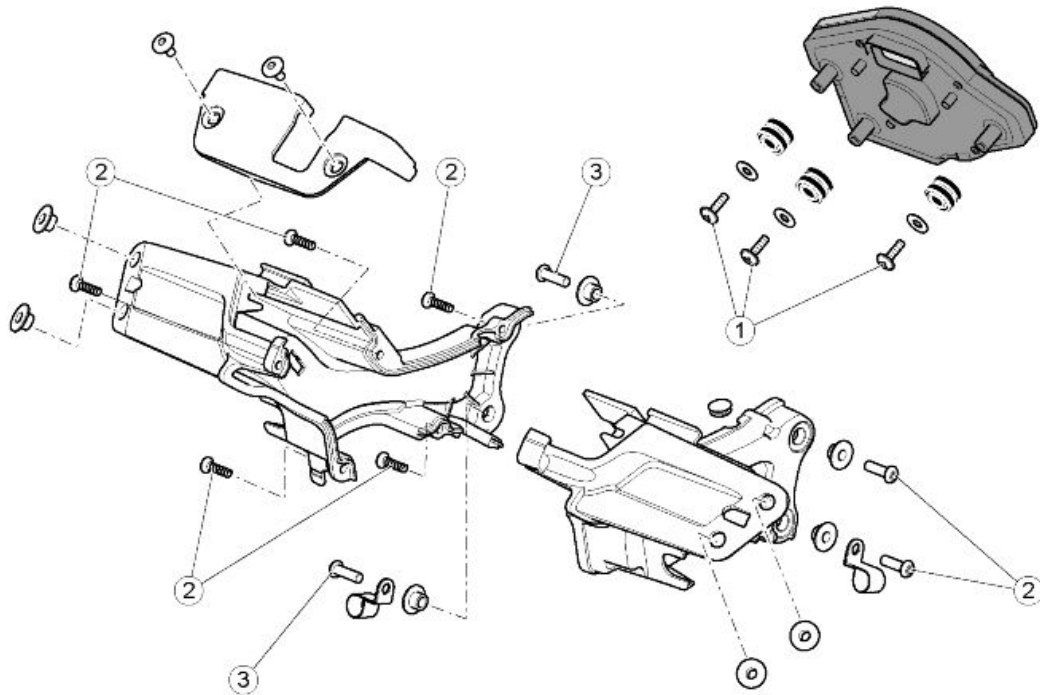
HANDLEBAR AND CONTROLS

pos.	Description	Type	Quantity	Torque	Notes
1	Screw fastening the semi-handlebar collar to the fork sleeves	M8	1 + 1	25 Nm (18.44 lbf ft)	-
2	Semi-handlebar safety screw	M6	1+1	10 Nm (7.37 lbf ft)	-
3	Anti-vibration counterweight fastener	M18x1.5	1+1	20 Nm (14.75 lbf ft)	-
4	Right light switch	M4	2	1.5 Nm (1.11 lbf ft)	-
5	Left light switch	M5	2	1.5 Nm (1.11 lbf ft)	-
6	Throttle control fixing screws	M5	2	2 Nm (1.47 lbf ft)	-

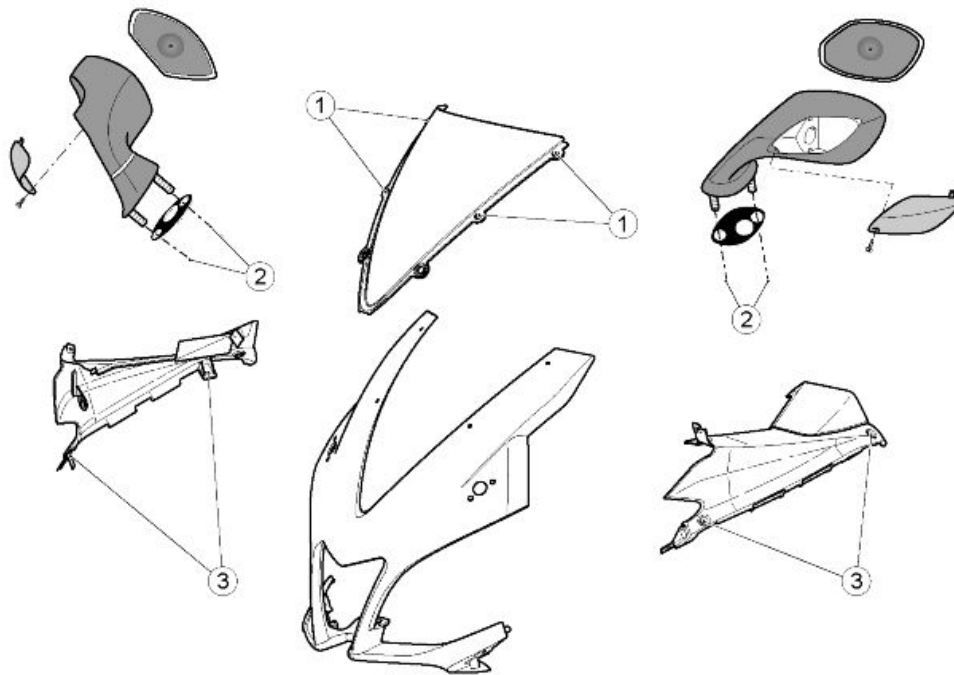


HEADLAMP

pos.	Description	Type	Quantity	Torque	Notes
1	Screw fastening headlamp to front fairing	SWP 4.9	4	2 Nm (1.47 lbf ft)	-
2	Headlamp fixing screw	M5	2 + 1	2 Nm (1.47 lbf ft)	-

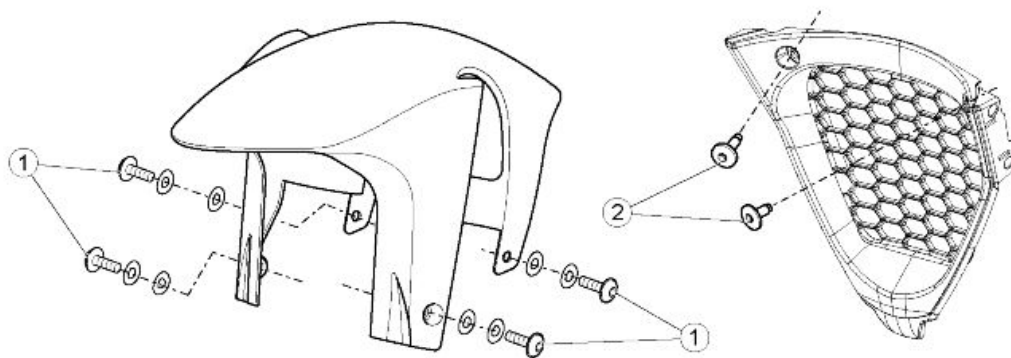
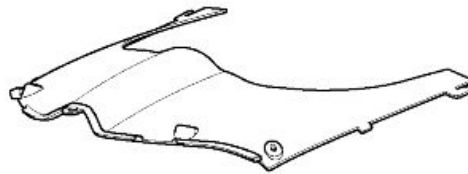
**INSTRUMENT PANEL**

pos.	Description	Type	Quantity	Torque	Notes
1	Screws fastening the rubber rings to the instrument panel	SWP 4.9	3	3 Nm (2.21 lbf ft)	-
2	Instrument panel mounting shell fixing screws	SWP 4.9	5	2 Nm (1.47 lbf ft)	-
3	Screws fastening instrument panel mounting to chassis	M6	4	8 Nm (5.9 lbf ft)	-



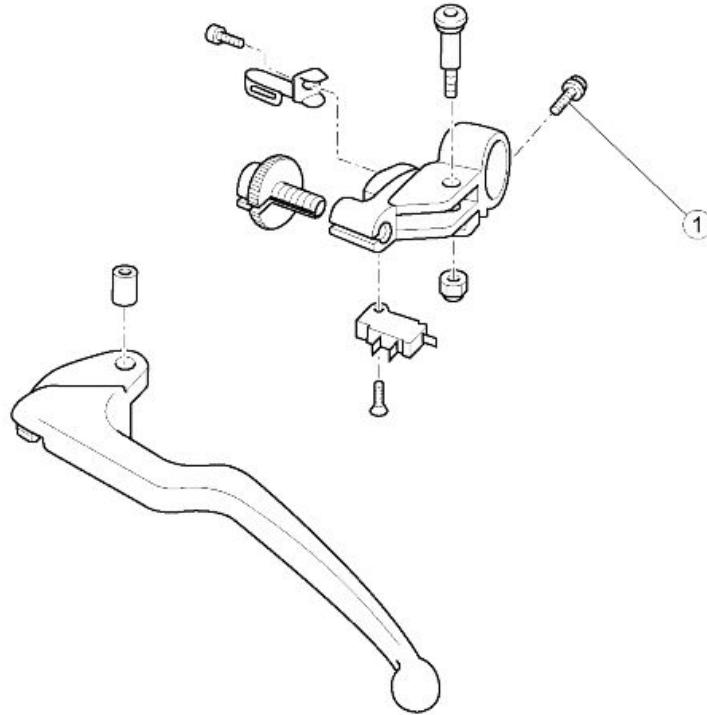
WINDSHIELD

pos.	Description	Type	Quantity	Torque	Notes
1	Windshield fixing screws	M4	4	0.5 Nm (0.37 lbf ft)	-
2	Rear-view mirror fixing nuts	M6	2 + 2	10 Nm (7.37 lbf ft)	-
3	- Screws fastening the side fairings to front fairing	M5	4	1 Nm (0.74 lbf ft)	-



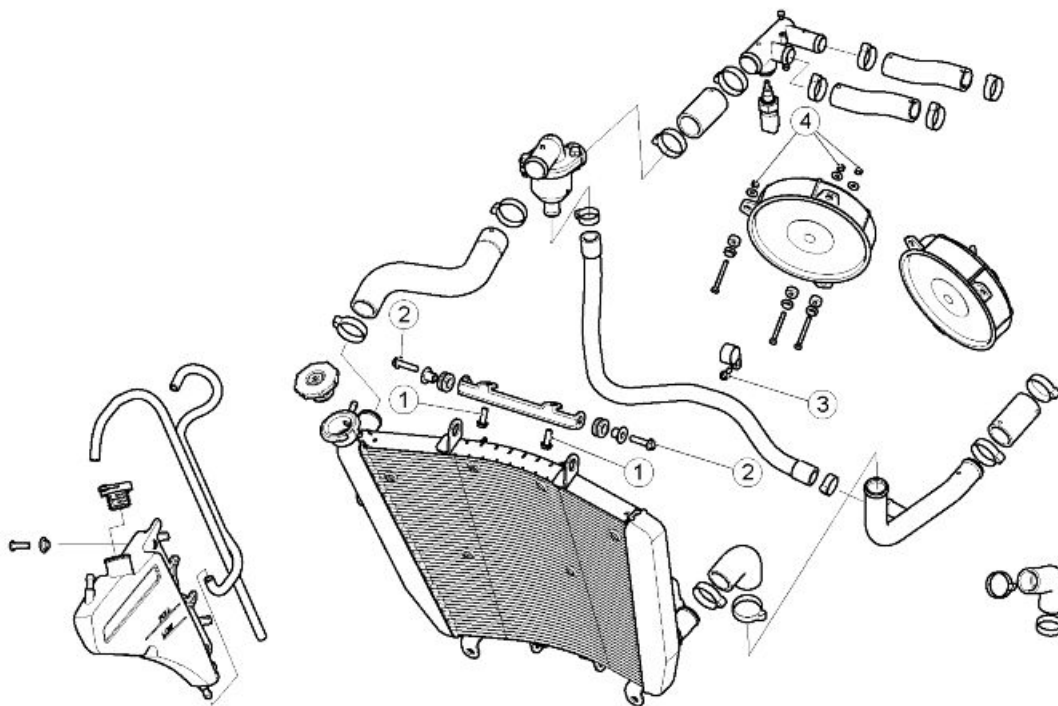
FRONT MUDGUARD

pos.	Description	Type	Quantity	Torque	Notes
1	Front mudguard fixing screws	M5	4	3 Nm (2.21 lbf ft)	-
2	Lug fixing screws	M5	2	4 Nm (2.95 lbf ft)	-



CLUTCH LEVER

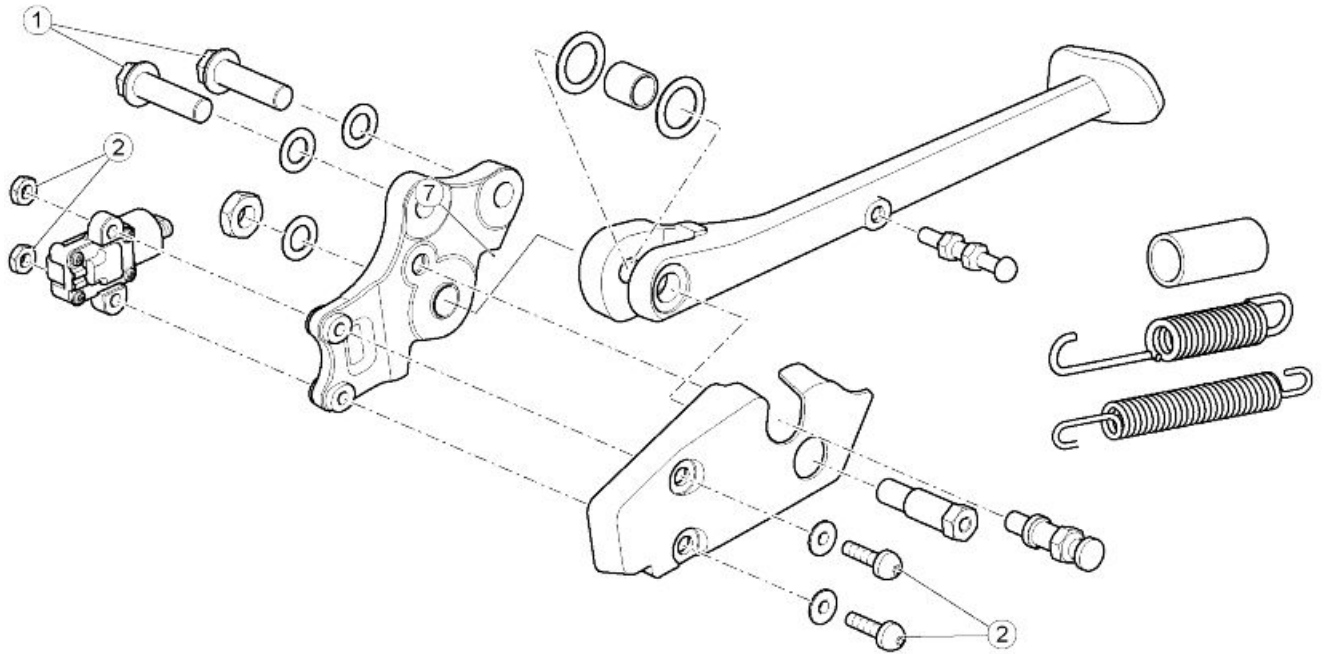
pos.	Description	Type	Quantity	Torque	Notes
1	Clutch lever collar fixing screws	M6	1	10 Nm (7.37 lbf ft)	-



COOLING

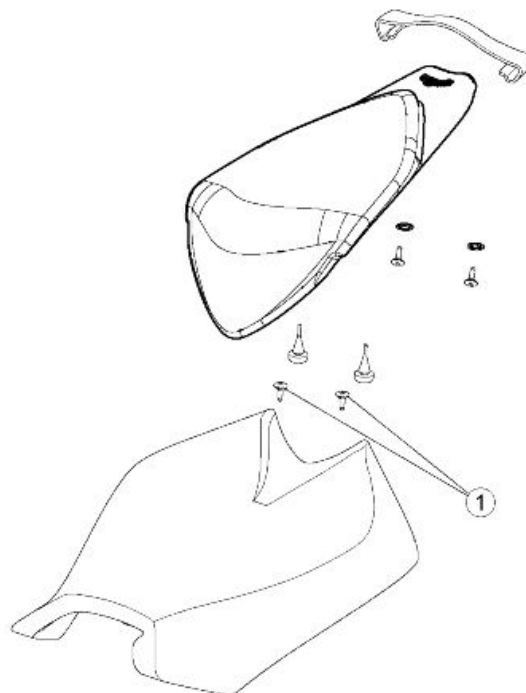
pos.	Description	Type	Quantity	Torque	Notes
1	Screws fastening water radiator mounting bracket to chassis	M6	2	10 Nm (7.37 lbf ft)	-
2	Screws fastening water radiator to mounting bracket	M6	2	7 Nm (5.16 lbf ft)	-
3	Screw fastening pipe grommet for By-pass water hose	M5	1	6 Nm (4.42 lbf ft)	-
4	Screws fastening electric fan to water radiator	M4	6	2 Nm (1.47 lbf ft)	-

Central part



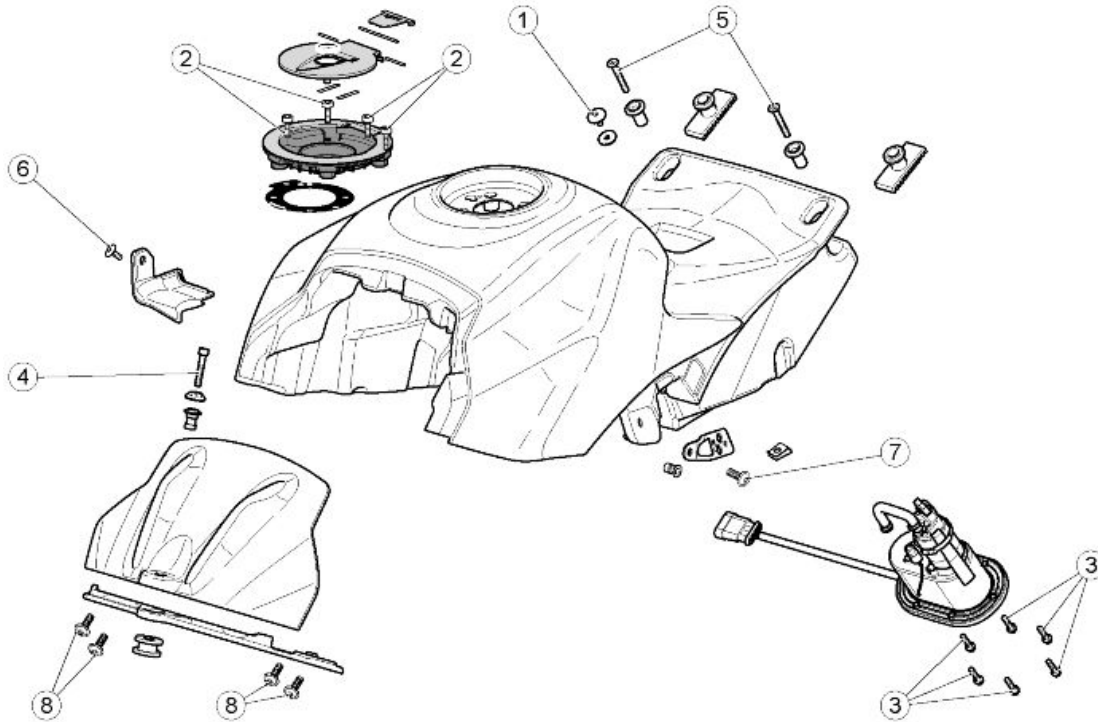
SIDE STAND

pos.	Description	Type	Quantity	Torque	Notes
1	Screws fastening the stand to the chassis	M10	2	45 Nm (33.19 lbf ft)	Loct. 243
2	Linear switch retainer	M5	2	4 Nm (2.95 lbf ft)	-
-	Rear stand bushing fastening screws	M6	2	7 Nm (5.16 lbf ft)	-



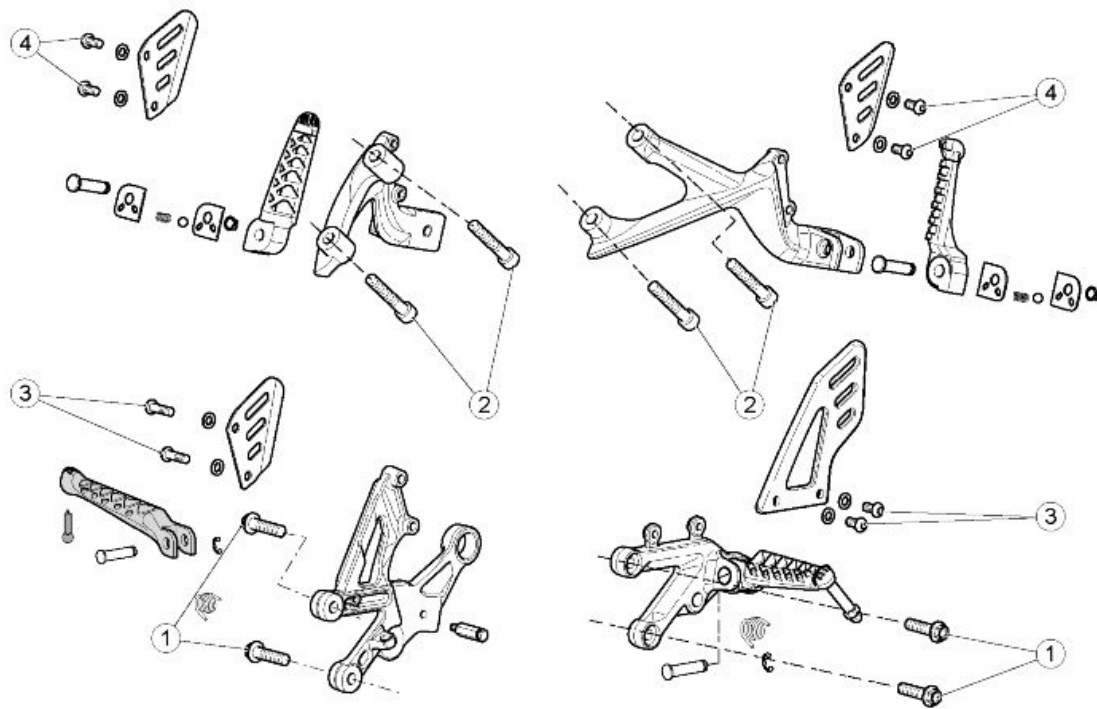
SADDLE

pos.	Description	Type	Quantity	Torque	Notes
1	Rider saddle fixing screw	M5	2	6 Nm (4.42 lbf ft)	-



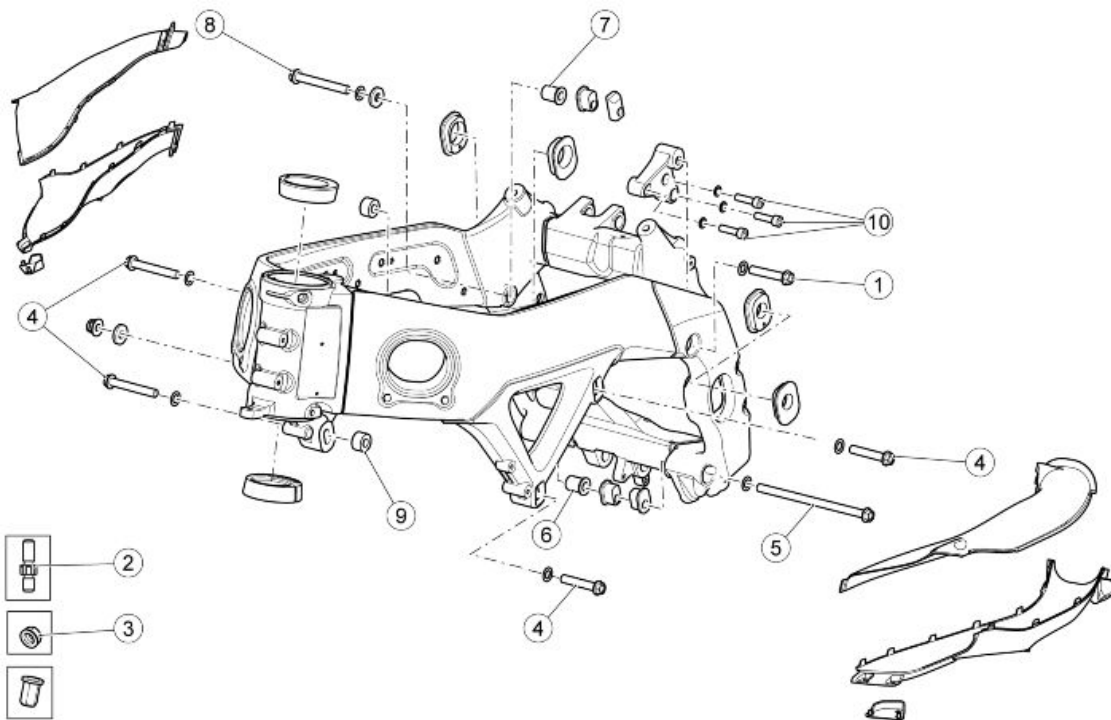
FUEL TANK

pos.	Description	Type	Quantity	Torque	Notes
1	Special screw fastening rider saddle to the tank	M6	1	4 Nm (2.95 lbf ft)	-
2	Screws fixing the filler to the tank	M5	4	4 Nm (2.95 lbf ft)	-
3	Screws fixing the fuel pump flange to the tank	M5	8	3 Nm (2.21 lbf ft)	-
4	Front screws fastening the tank to the chassis	M6	1	8 Nm (5.9 lbf ft)	-
5	Rear screws fastening the tank to the rear chassis	M6	2	7 Nm (5.16 lbf ft)	-
6	Screws fastening plastic fuel pipe mounting	M5	1	2.5 Nm (1.84 lbf ft)	-
7	Left fairing mounting bracket fixing screws	M5	1	3 Nm (2.21 lbf ft)	-
8	Screws fastening structural tank mounting to tank	M6	4	3 Nm (2.21 lbf ft)	-
-	Central screw fastening the cover to the tank	M4	1	0.5 Nm (0.37 lbf ft)	-
-	Fuel tank breather pipe unions	M7	2	3 Nm (2.21 lbf ft)	-



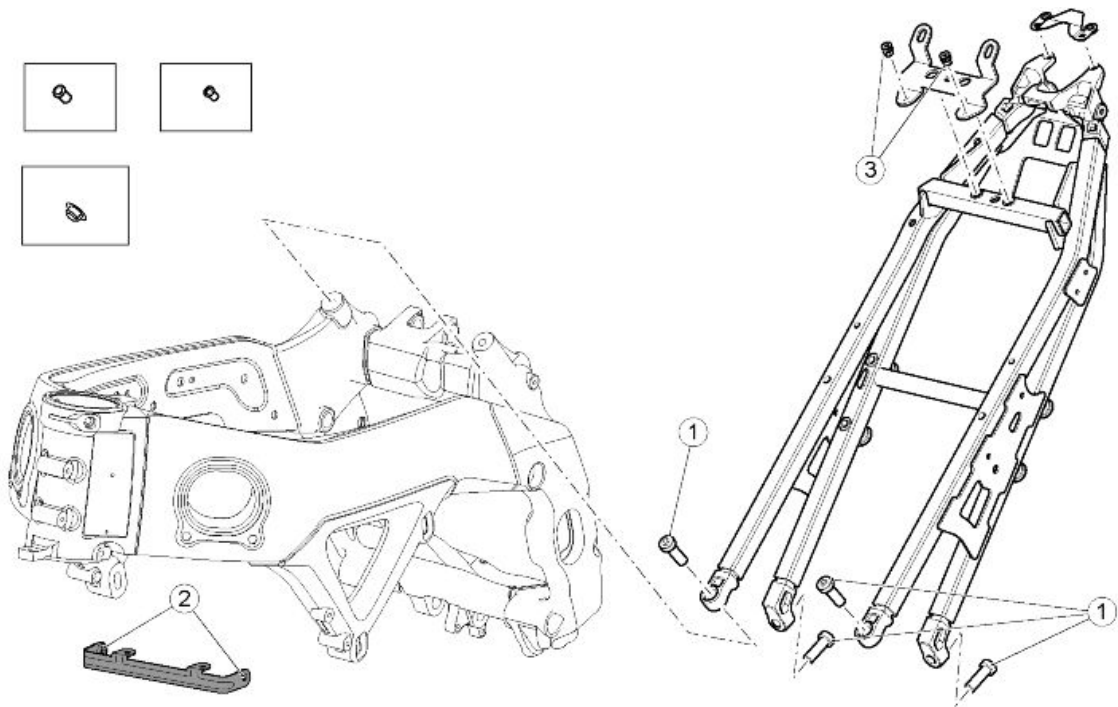
FOOTRESTS

pos.	Description	Type	Quantity	Torques	Notes
1	Screws fastening rider footpegs to chassis	M8	2 + 2	25 Nm (18.44 lbf ft)	-
2	Screws fastening passenger footpegs to chassis	M8	2 + 2	18 Nm (13.28 lbf ft)	For countries in which passenger footpegs are mandatory or for two seat configuration
3	Rider heelrest fixing screws	M6	2 + 2	8 Nm (5.9 lbf ft)	-
4	Passenger heelrest fixing screws	M6	2 + 2	8 Nm (5.9 lbf ft)	-
-	Anti-slip pin	M6	1	8 Nm (5.9 lbf ft)	-



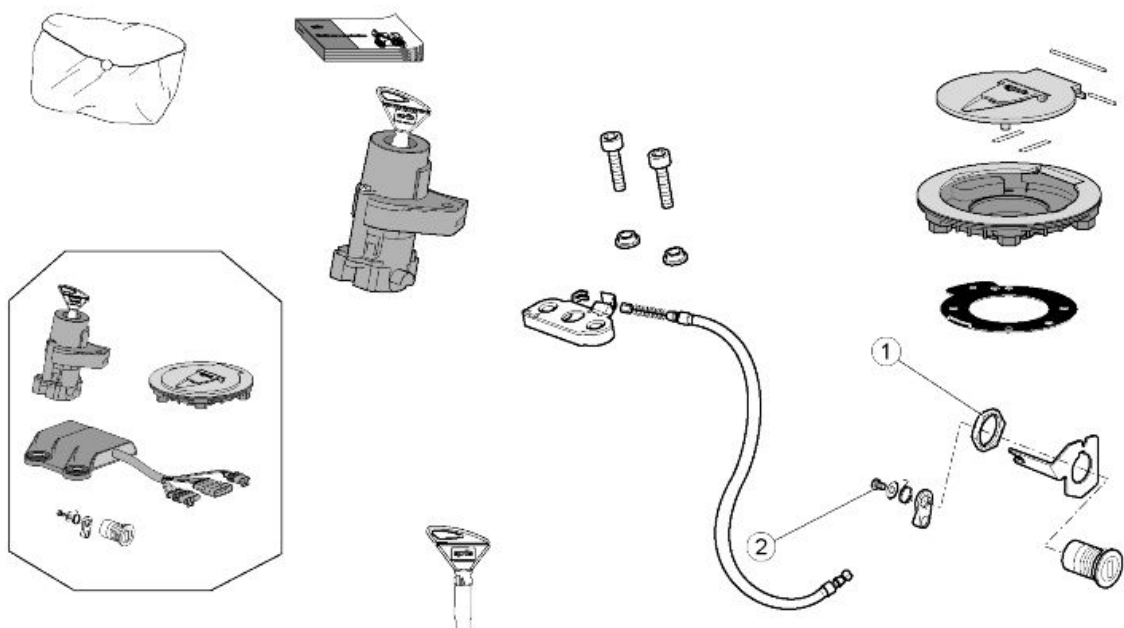
FRONT CHASSIS

pos.	Description	Type	Quantity	Torque	Notes
1	Upper rear mount	M10	1	50 Nm (36.88 lbf ft)	-
2	Threaded intake duct fastener pins	M6	2 + 2	4 Nm (2.95 lbf ft)	Loct. 243
3	Intake duct fixing nuts	M6	2 + 2	Manual	-
4	Front mounts	M10	2 + 2	50 Nm (36.88 lbf ft)	-
5	Lower rear mount	M10	1	50 Nm (36.88 lbf ft)	-
6	Lower rear right hand adjuster screw bushing	M18x1.5	1	12 Nm (8.85 lbf ft)	-
7	Upper rear right hand adjuster screw bushing	M18x1.5	1	12 Nm (8.85 lbf ft)	-
8	Upper rear right hand mount	M10	1	50 Nm (36.88 lbf ft)	-
9	Right fairing spacer	M6	1	10 Nm (7.37 lbf ft)	Loct. 243
10	Upper rear left hand engine mount fastener screws	M8	3	25 Nm (18.44 lbf ft)	-
-	Screw fastening the ground cable to the left side chassis	M6	1	6 Nm (4.42 lbf ft)	-



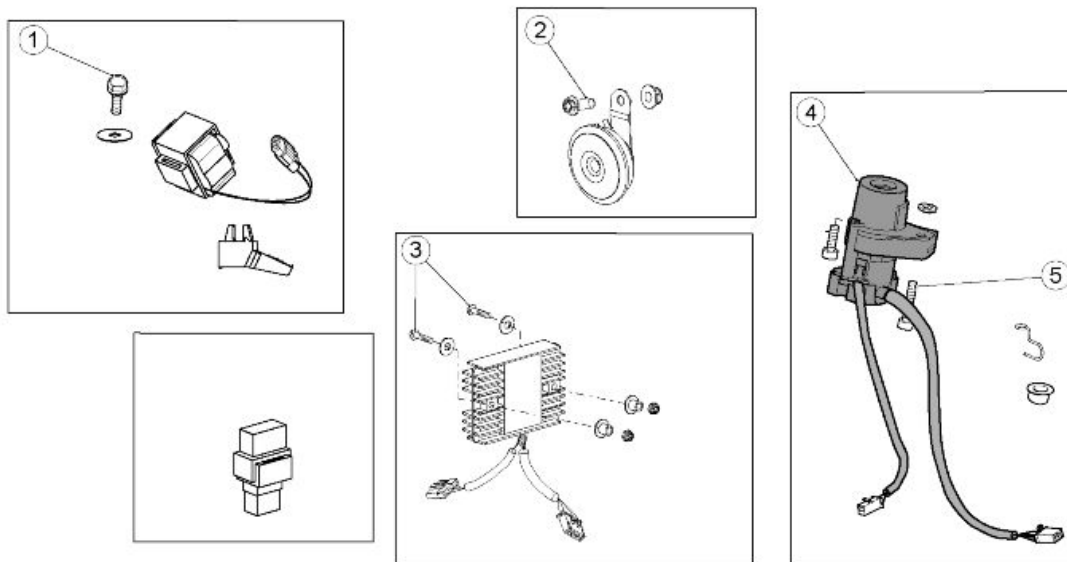
REAR CHASSIS

pos.	Description	Type	Quantity	Torque	Notes
1	Saddle mounting fixing screws	M10	4	50 Nm (36.88 lbf ft)	-
2	Screws fastening oil radiator mounting bracket to engine	M6	2	8 Nm (5.9 lbf ft)	-
3	Passenger saddle and saddle cover catch plate fixing screws	M6	2	8 Nm (5.9 lbf ft)	-



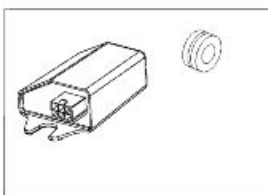
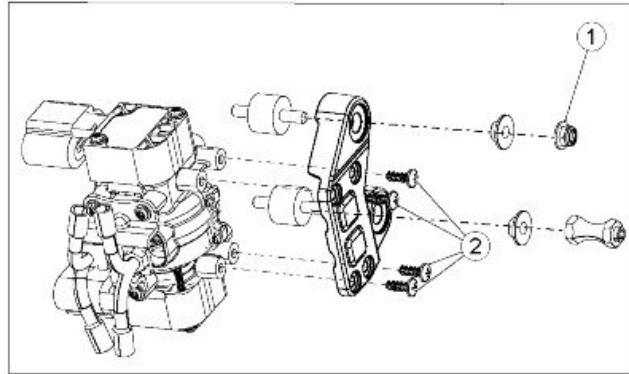
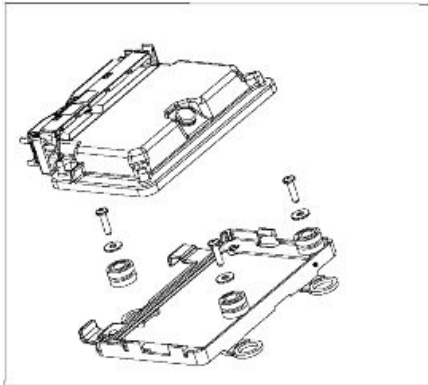
LOCKS

pos.	Description	Type	Quantity	Torque	Notes
1	Nut fastening saddle lock to tail fairing	M22x1.5	1	5 Nm (3.69 lbf ft)	-
2	Lock lever self-tapping screw	M4	1	2 Nm (1.47 lbf ft)	-



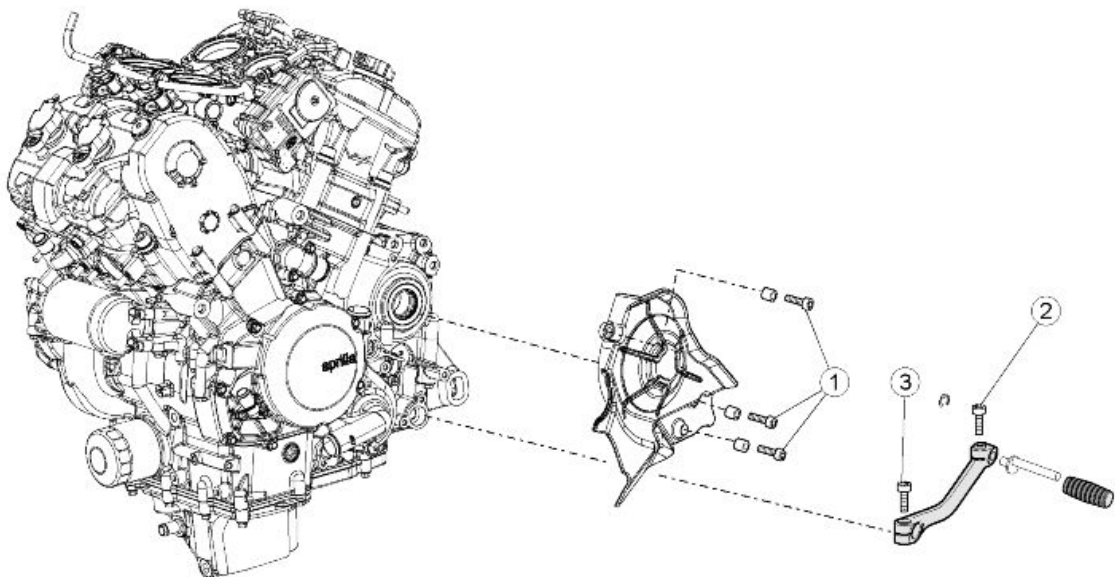
FRONT ELECTRICAL SYSTEM

pos.	Description	Type	Quantity	Torque	Notes
1	Fall sensor mounting fixing screw	M6	1	8 Nm (5.9 lbf ft)	-
2	Horn fixing screw	M8	1	15 Nm (11.06 lbf ft)	-
3	Screw fastening the voltage regulator to the inner fairing	M6	2	6 Nm (4.42 lbf ft)	-
4	Shear head screw (to the left of the ignition lock)	M8	1	Manual	Tighten until the head shears off
5	Right hand ignition lock screw	M8	1	20 Nm (14.75 lbf ft)	-



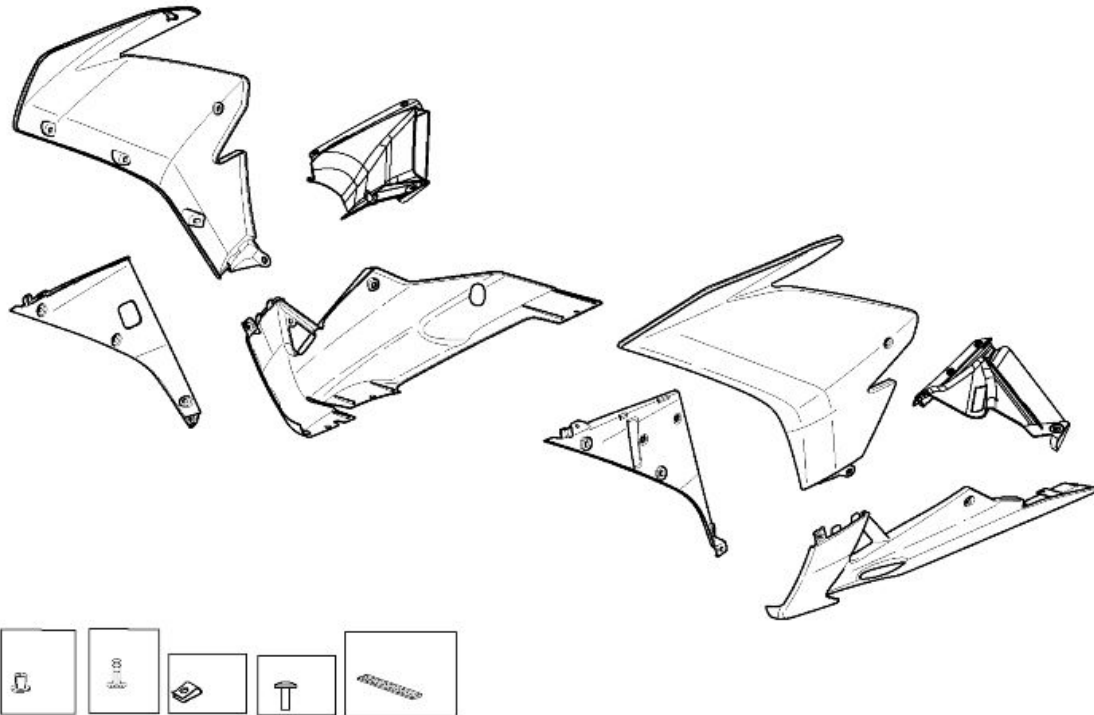
CENTRAL ELECTRICAL SYSTEM

pos.	Description	Type	Quantity	Torque	Notes
1	Upper Silentblock nut, demand sensor mounting bracket	M6	1	5 Nm (3.69 lbf ft)	-
2	Demand sensor fixing screw to mounting plate	SWP 4.9	4	1.2 Nm (0.88 lbf ft)	-



ENGINE

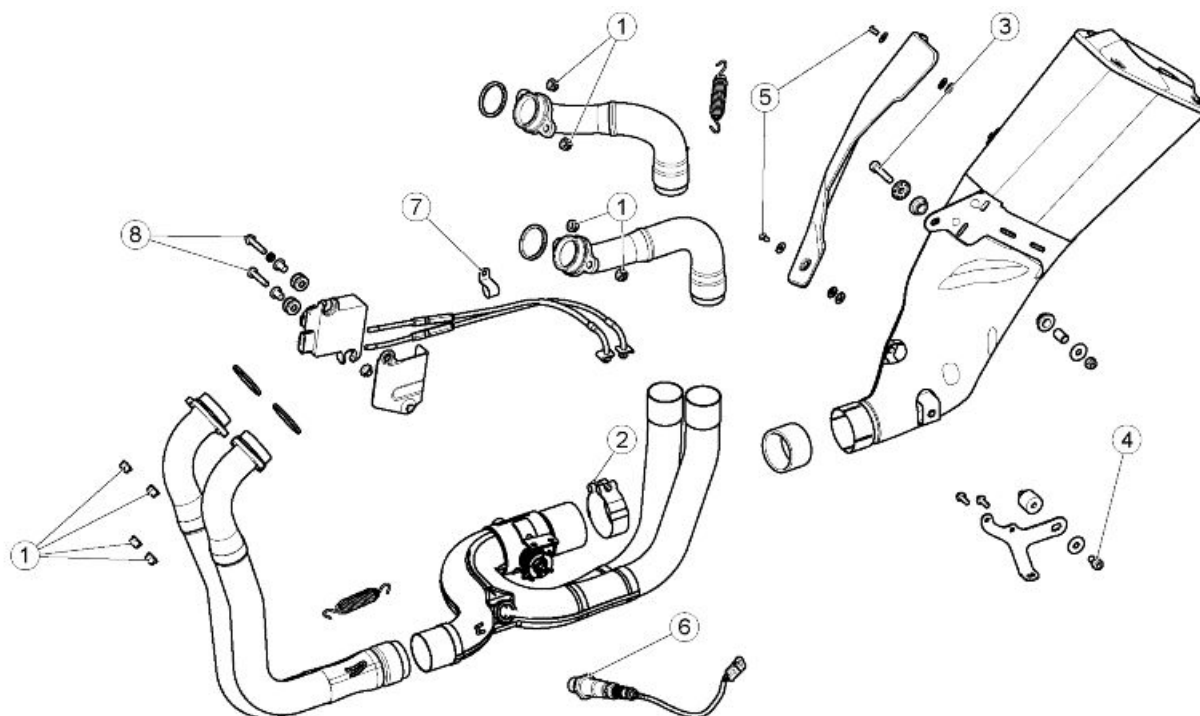
pos.	Description	Type	Quantity	Torques	Notes
1	Pinion protector casing fixing screws	M6	3	8 Nm (5.9 lb ft)	-
2	Gearbox lever pin fixing screw	M6	1	10 Nm (7.37 lbf ft)	-
3	Gearbox lever fixing screws	M6	1	10 Nm (7.37 lbf ft)	-



FAIRING

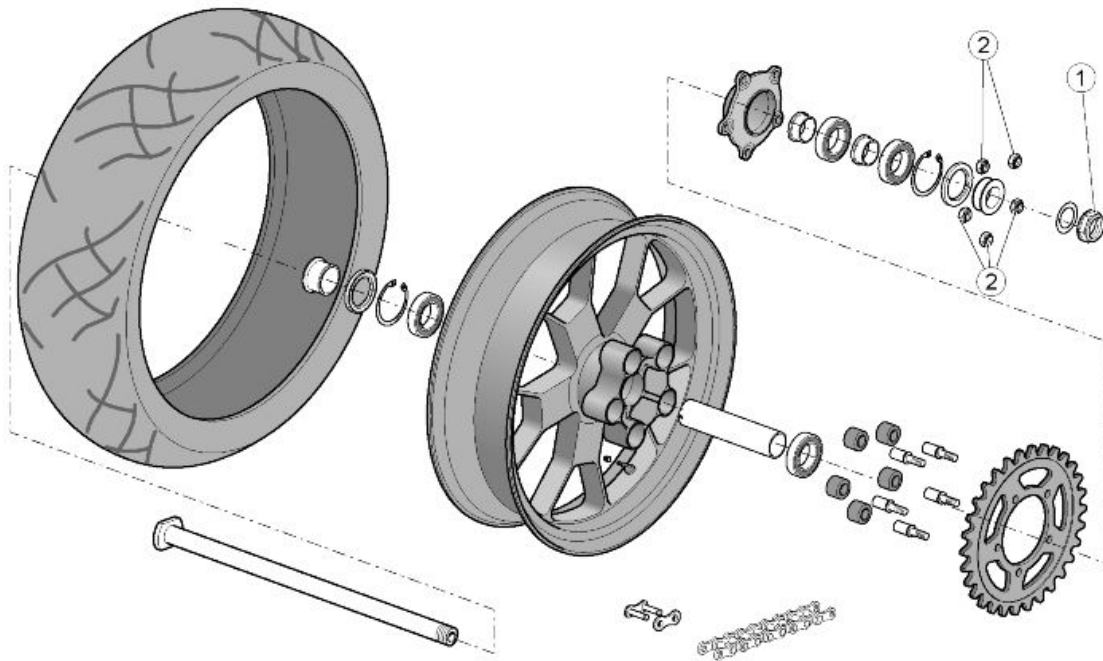
pos.	Description	Type	Quantity	Torque	Notes
-	Centre screws fastening lower fairing	M6	2	10 Nm (7.37 lb ft)	-
-	Right hand lower fairing mounting bracket	M6	2	10 Nm (7.37 lb ft)	-
-	Left hand lower fairing mounting bracket	M6	2	10 Nm (7.37 lb ft)	-
-	Screws fixing the side fairings to the side spacers	M5	2	1.5 Nm (1.11 lb ft)	-
-	Screws fixing upper fairing fastener to intake duct	M5	2	1.5 Nm (1.11 lb ft)	-
-	Screws fixing upper fairing fastener to front fairing	M5	2	1.5 Nm (1.11 lb ft)	-
-	Screws fixing upper fairing fastener to intake duct	self-tapping	2	1 Nm (0.74 lb ft)	-
-	Screws fixing upper fairing fastener to headlamp	self-tapping	2	1 Nm (0.74 lb ft)	-
-	Screws fastening the lower fairing to the bracket	M5	2 + 2	1 Nm (0.74 lb ft)	-
-	Screws fastening the lower fairing to the lug	M5	2	2 Nm (1.47 lb ft)	-
-	Lower fairing lower fastening screws	M5	2	2 Nm (1.47 lb ft)	-
-	Lower fork fastener fixing screws	M6	2	8 Nm (5.90 lb ft)	-
-	Screws fixing lower front fairing fastener to intake ducts	SWP 3.9	2	1 Nm (0.74 lb ft)	-
-	Inner screws fixing fairing to the lower front fairing fastener	M4	2	0.5 Nm (0.37 lb ft)	-
-	Inner screws fastening the fairing to the lug	M5	2	2 Nm (1.47 lb ft)	-

Back side



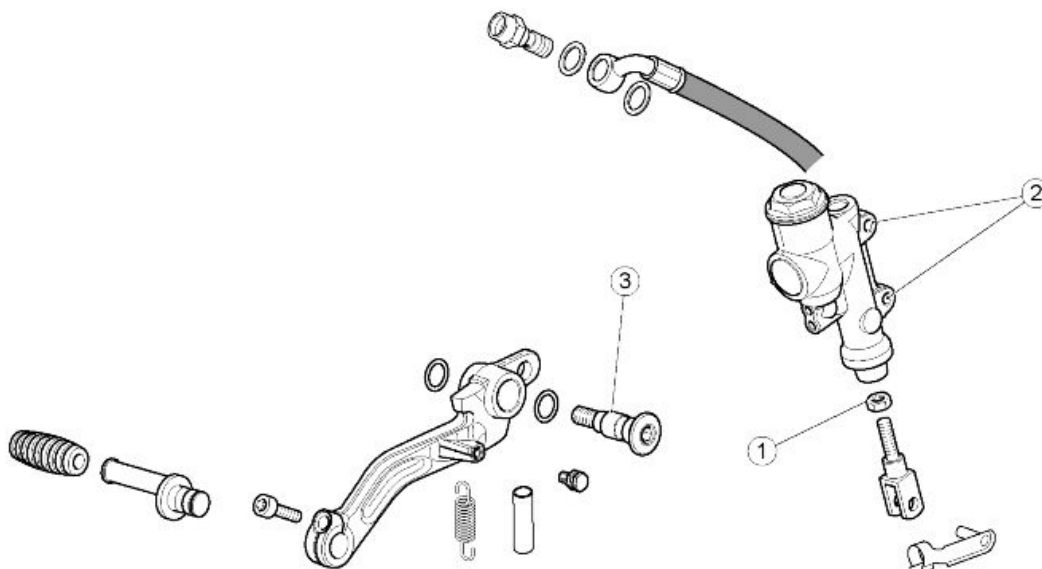
EXHAUST

pos.	Description	Type	Quantity	Torque	Notes
1	Exhaust manifold flange fixing nuts	M7	8	13 Nm (9.59 lbf ft)	-
2	Silencer clamp fixing screw	M6	1	10 Nm (7.37 lbf ft)	-
3	Screw fastening silencer to right hand footpeg mounting	M8	1	25 Nm (18.44 lbf ft)	-
4	Screw fastening silencer to central lower fairing bracket	M8	1	20 Nm (14.75 lbf ft)	-
5	Cosmetic silencer shield fixing screw	M5	2	5 Nm (3.69 lbf ft)	-
6	Oxygen sensor fastener	M18x1.5	1	38 Nm (28.03 lbf ft)	-
7	Fastener screw for cable grommet for exhaust butterfly valve cables	M6	1	10 Nm (7.37 lbf ft)	-
8	Exhaust butterfly valve actuator fixing screws	M6	2	10 Nm (7.37 lbf ft)	-



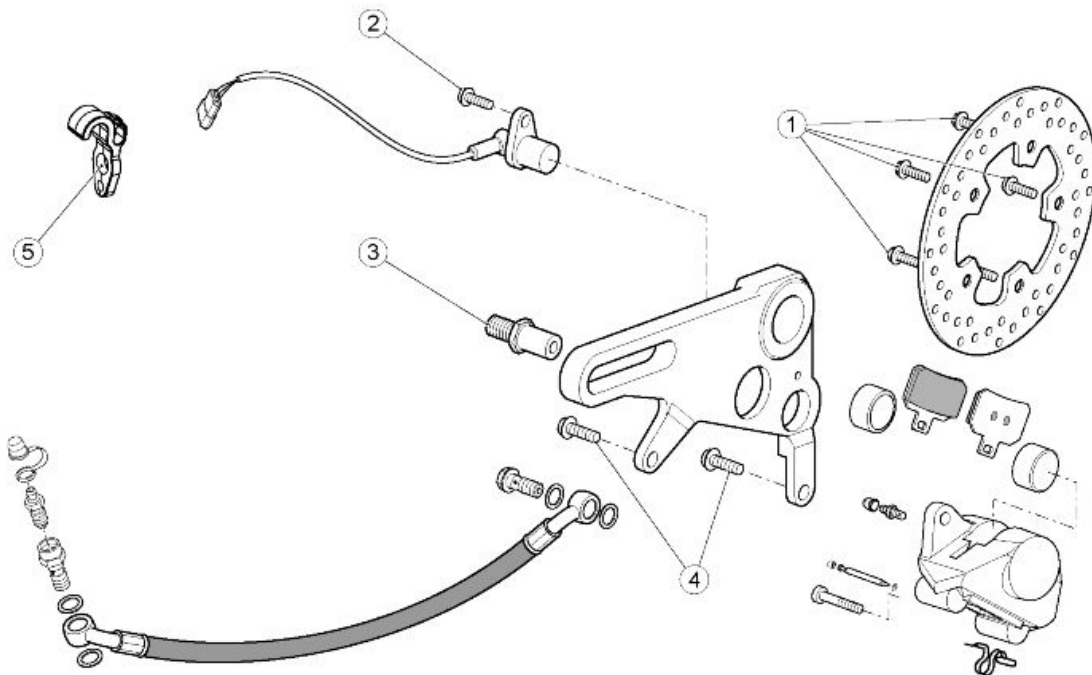
REAR WHEEL

pos.	Description	Type	Quantity	Torque	Notes
1	Rear wheel spindle nut	M25x1.5	1	120 Nm (88.5 lbf ft)	-
2	Screws fastening sprocket on sprocket mount	M10	5	50 Nm (36.88 lbf ft)	-

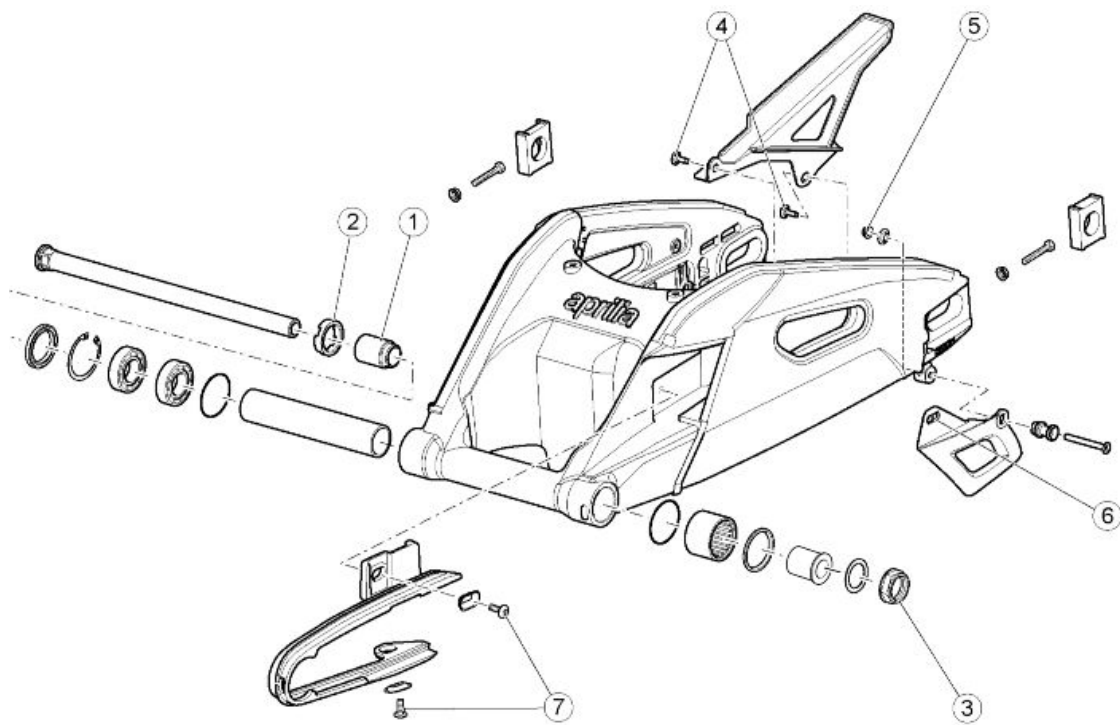


REAR BRAKE PUMP

pos.	Description	Type	Quantity	Torque	Notes
1	Rear brake rod lock nut	M6	1	12 Nm (8.85 lbf ft)	-
2	Rear brake pump fixing screws	M6	2	8 Nm (5.9 lbf ft)	-
3	Rear brake lever fixing screw	M8	1	25 Nm (18.44 lbf ft)	-

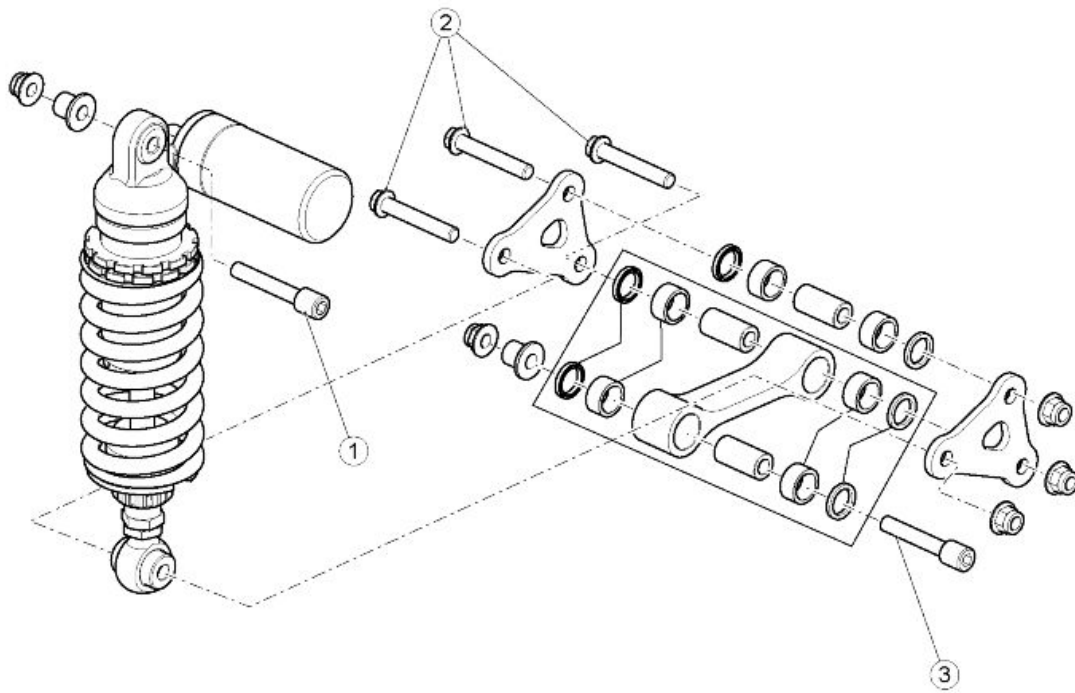
**REAR BRAKE CALLIPER**

pos.	Description	Type	Quantity	Torque	Notes
1	Rear brake disc fixing screws	M8	5	30 Nm (22.13 lbf ft)	Loct. 243
2	Screw fastening odometer sensor onto rear brake calliper mounting	M6	1	12 Nm (8.85 lbf ft)	-
3	Rear brake calliper mounting plate lock pin	M12	1	50 Nm (36.88 lbf ft)	Loct. 243
4	Rear calliper fixing screw	M5	2	25 Nm (18.44 lbf ft)	-
5	Brake pipe clamp fixing screw	M5	2	4 Nm (2.95 lbf ft)	-
-	Brake pipe bracket fixing screw	M5	2	4 Nm (2.95 lbf ft)	-



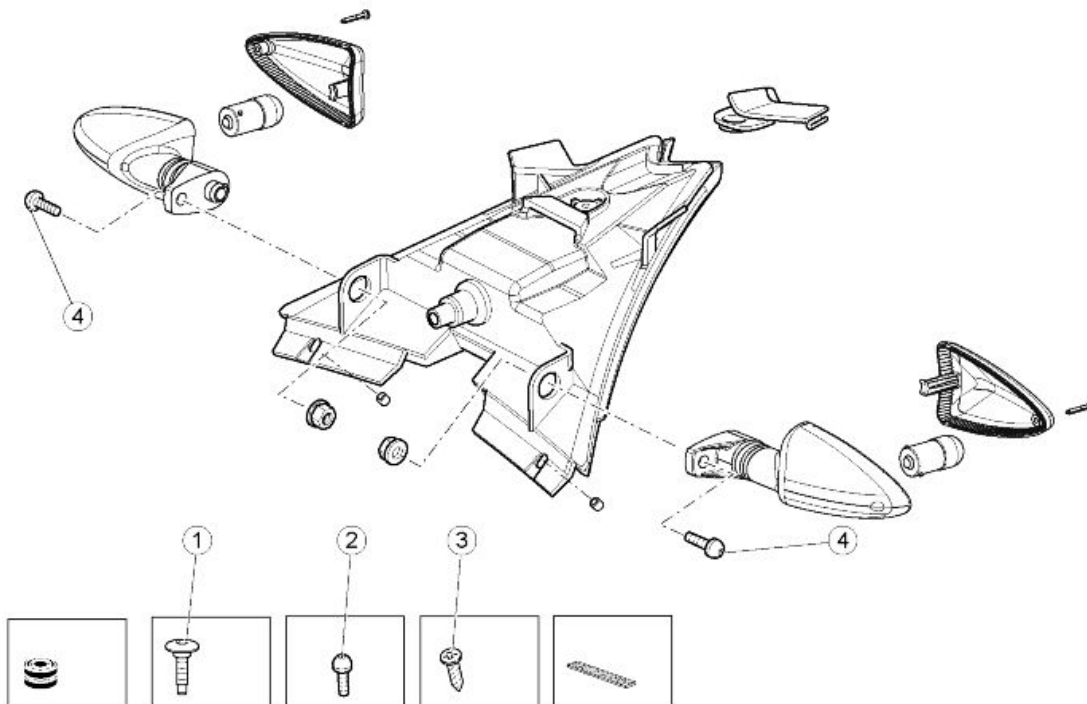
REAR SWINGARM

pos.	Description	Type	Quantity	Torque	Notes
1	Swingarm adjuster screw bushing	M30x1.5	1	12 Nm (8.85 lbf ft)	-
2	Swingarm ring nut	M30x1.5	1	60 Nm (44.25 lbf ft)	-
3	Swingarm pin nut	M20x1.5	1	65 Nm (47.94 lbf ft)	AGIP GREASE SM2
4	Chain casing fixing screws	M5	2	4 Nm (2.95 lbf ft)	-
5	Front chain guide fixing screw	M5	1	4 Nm (2.95 lbf ft)	-
6	Rear chain guide fixing nut	M6	1	7 Nm (5.16 lbf ft)	-
7	Chain skid fixing screws	M5	2	2 Nm (1.47 lbf ft)	-
-	Lower chain slider fixing screws	M6	2	10 Nm (7.37 lbf ft)	-
-	Chain guide fixing screw	M6	1	8 Nm (5.90 lbf ft)	-



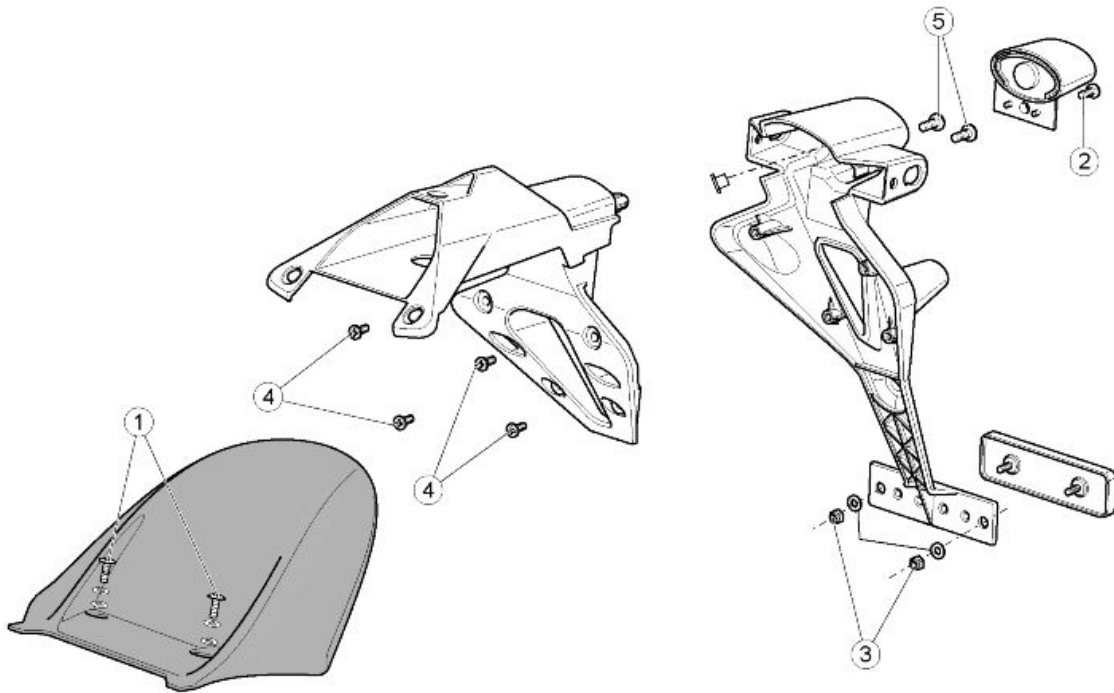
REAR SHOCK ABSORBER

pos.	Description	Type	Quantity	Torque	Notes
1	Upper shock absorber fixing screw	M10	1	50 Nm (36.88 lbf ft)	-
2	Dual connecting rod fixing screw	M10	3	50 Nm (36.88 lbf ft)	-
3	Screw fastening single connecting rod to chassis	M10	1	50 Nm (36.88 lbf ft)	-



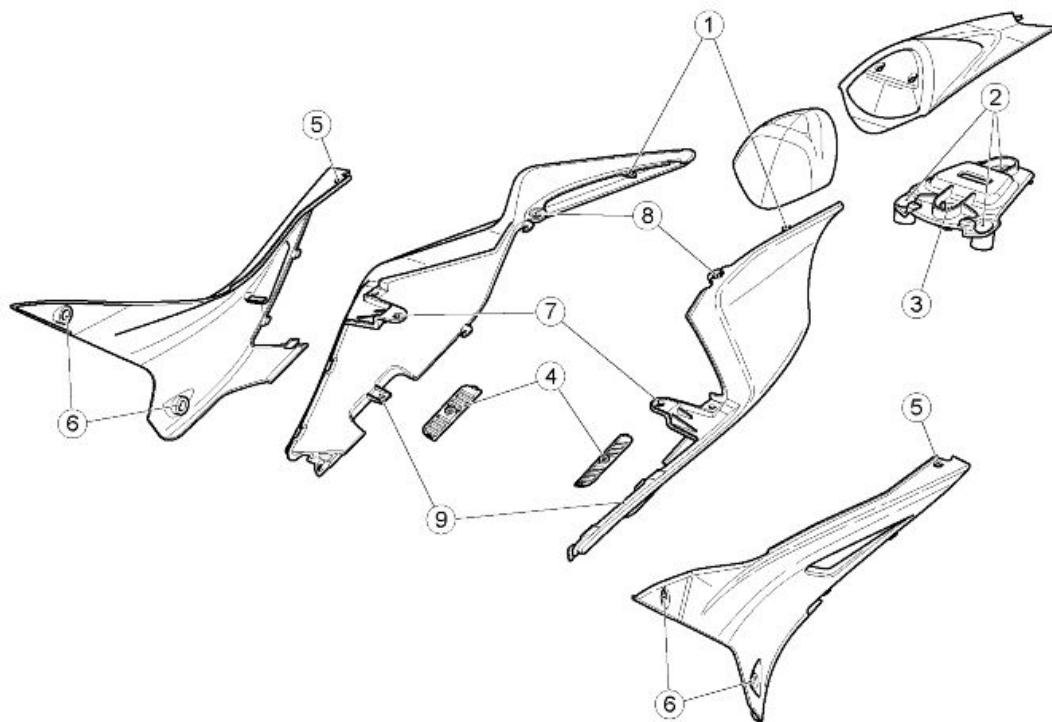
TAILLIGHT

pos.	Description	Type	Quantity	Torque	Notes
1	Taillight fixing screws	M5	2	3 Nm (2.21 lbf ft)	-
2	Taillight mounting bracket fixing screws	M5	2	4 Nm (2.95 lbf ft)	-
3	Rear turn indicator fixing screws	M6	2	2.5 Nm (1.84 lbf ft)	-
4	Taillight cover fixing screws	SWP 2.9	1	0.5 Nm (0.37 lbf ft)	-



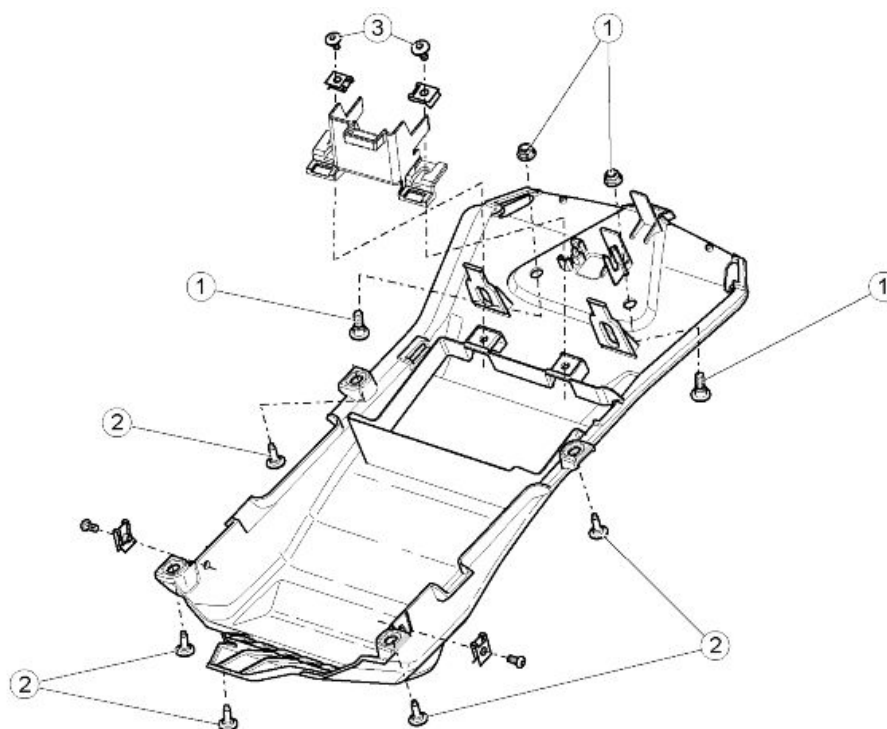
LICENSE PLATE HOLDER

pos.	Description	Type	Quantity	Torque	Notes
1	Rear mudguard fixing screws	M6	2	3 Nm (2.21 lbf ft)	-
2	License plate light fixing screws	M4	1	1 Nm (0.74 lbf ft)	-
3	Reflector fixing nuts	M4	2	1 Nm (0.74 lbf ft)	-
4	Screws fastening rear license plate holder to front license plate holder	SWP 3.9	4	1 Nm (0.74 lbf ft)	-
5	Screws fastening rear license plate holder to front license plate holder	SWP 4.9	2	2 Nm (1.47 lbf ft)	-
-	Screws fastening license plate mounting to saddle mounting casting	M6	3	4 Nm (2.95 lbf ft)	-



TAIL FAIRING

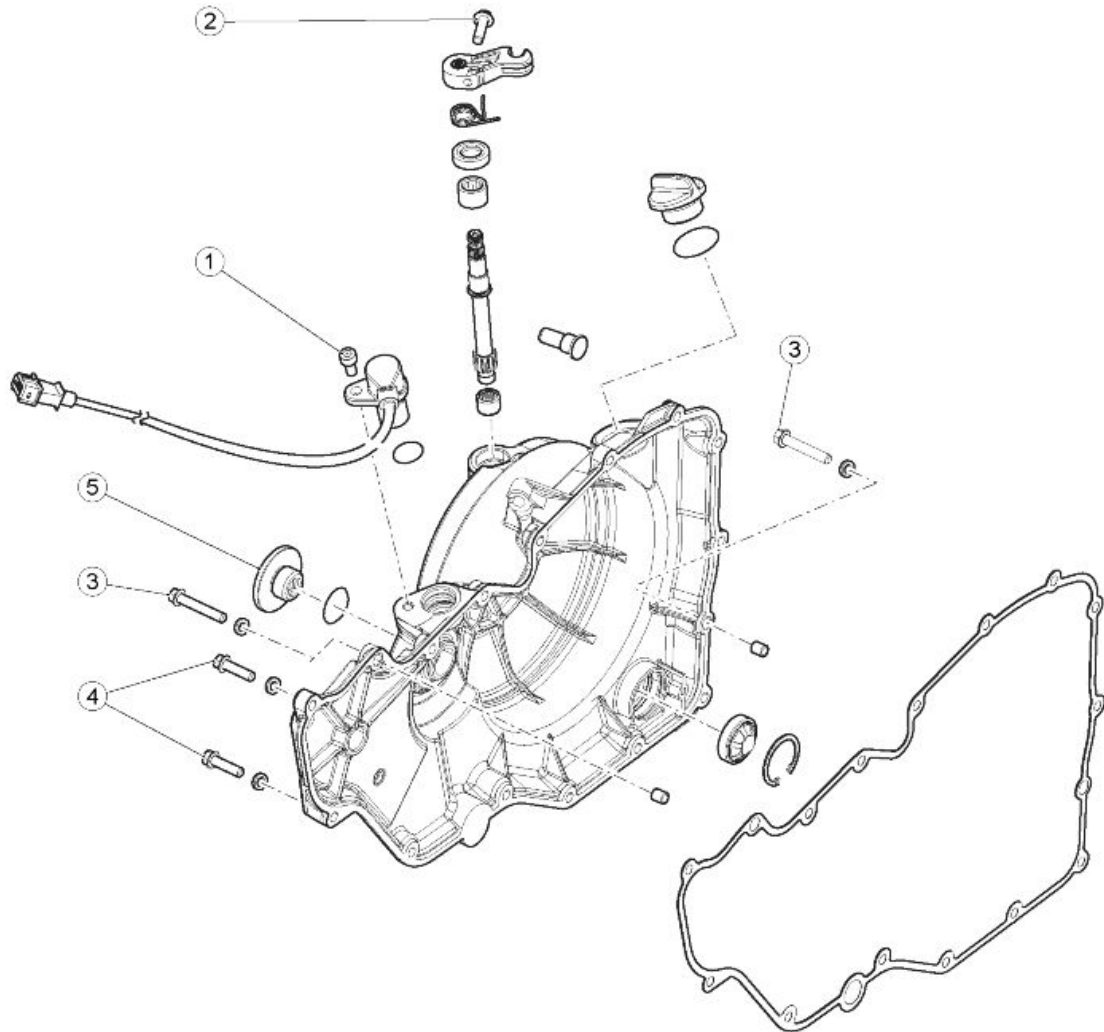
pos.	Description	Type	Quantity	Torque	Notes
1	Rear screws fastening tail fairing to taillight bracket	M5	2	3 Nm (2.21 lbf ft)	-
2	Screws fastening the saddle cover base to the saddle cover	SWP 2.9	3	1 Nm (0.74 lbf ft)	-
3	Saddle cover pin fixing screws	M4	1	1.5 Nm (1.11 lbf ft)	-
4	Screws fastening grilles to tail fairing	M5	2	0.5 Nm (0.37 lbf ft)	-
5	Screws fastening side fairings to tail fairing	M5	2	1 Nm (0.74 lbf ft)	-
6	Screws fixing side fairings to tank	M5	2 + 2	2 Nm (1.47 lbf ft)	-
7	Screws fastening tail fairing to saddle mounting	M5	2	3 Nm (2.21 lbf ft)	-
8	Screws fastening tail fairing to saddle mounting bracket	M5	2	2 Nm (1.47 lbf ft)	-
9	Screws fixing tail fairing to lower saddle mounting fastener	M5	2	3 Nm (2.21 lbf ft)	-



HELMET COMPARTMENT

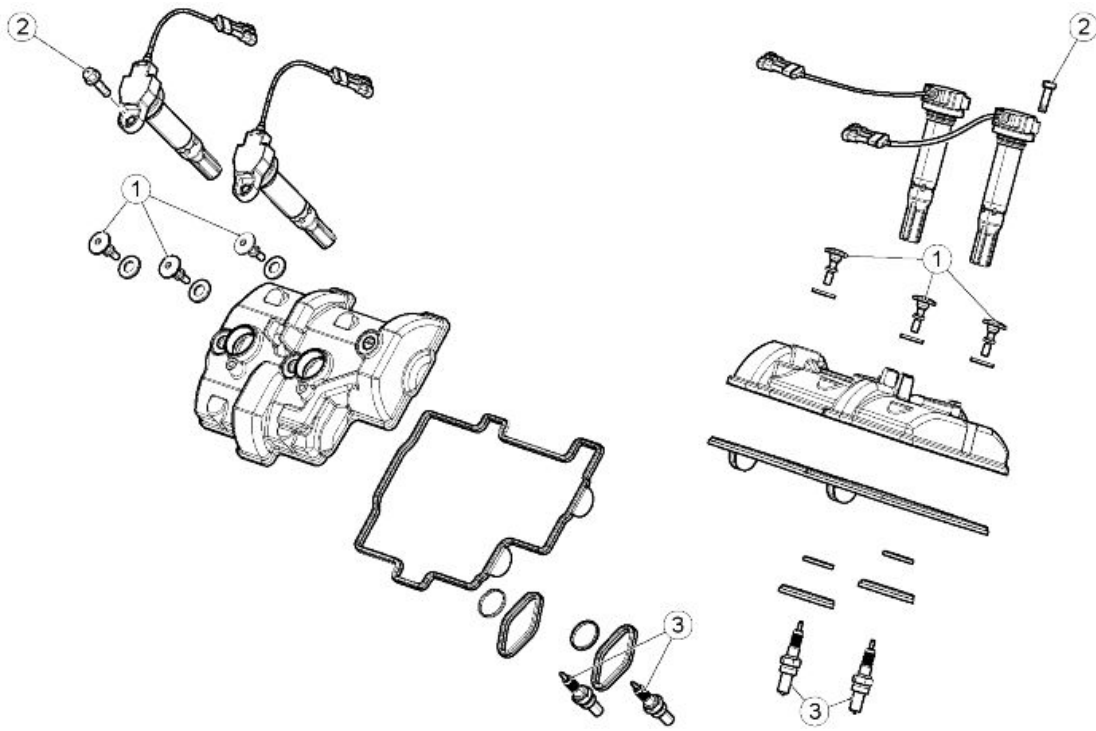
pos.	Description	Type	Quantity	Torque	Notes
1	Screws and nuts for fastening license plate holder to saddle mounting plate	M6	2	4 Nm (2.95 lbf ft)	-
2	Lower saddle mounting fastener fixing screws	M5	5	3 Nm (2.21 lbf ft)	-
3	Battery bracket fixing screws	M5	2	2 Nm (1.47 lbf ft)	-

Engine



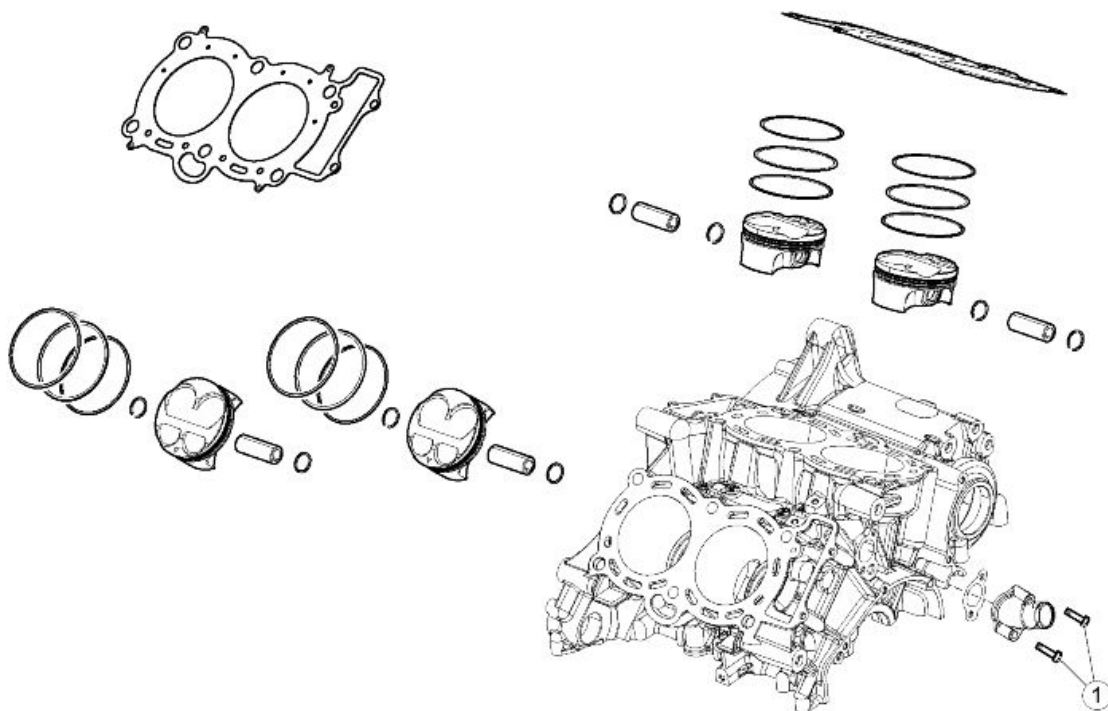
CLUTCH COVER

pos.	Description	Type	Quantity	Torque	Notes
1	Engine speed sensor fixing screw	-	1	8 Nm (5.9 lbf ft)	-
2	TE flanged screw	M6x20	1	12 Nm (8.85 lbf ft)	-
3	Flanged TE screws	M6x35	2	12 Nm (8.85 lbf ft)	-
4	Flanged TE screws	M6x22	16	12 Nm (8.85 lbf ft)	-
5	Engine timing inspection cap	-	1	25 Nm (18.44 lbf ft)	-



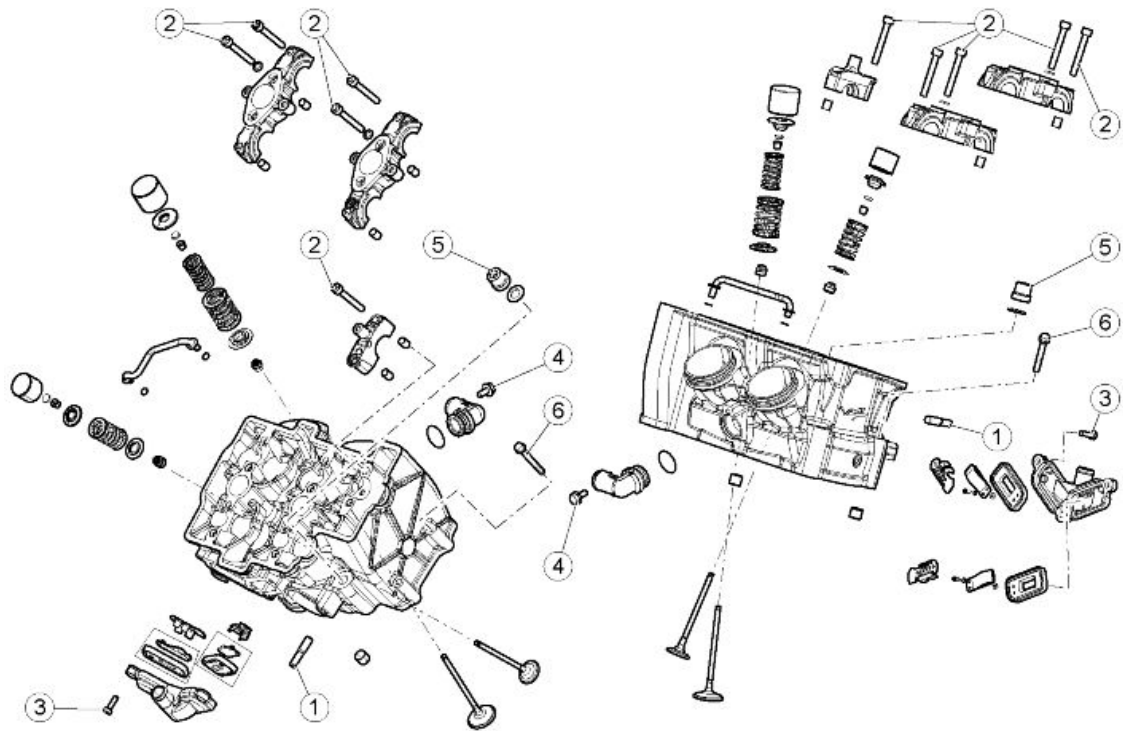
VALVE COVER

pos.	Description	Type	Quantity	Torque	Notes
1	Head cover fixing screws	-	6	10 Nm (7.37 lbf ft)	-
2	Coil fixing screws	-	4	8 Nm (5.9 lbf ft)	Loct. 243
3	Spark plugs	-	4	12 Nm (8.85 lbf ft)	-



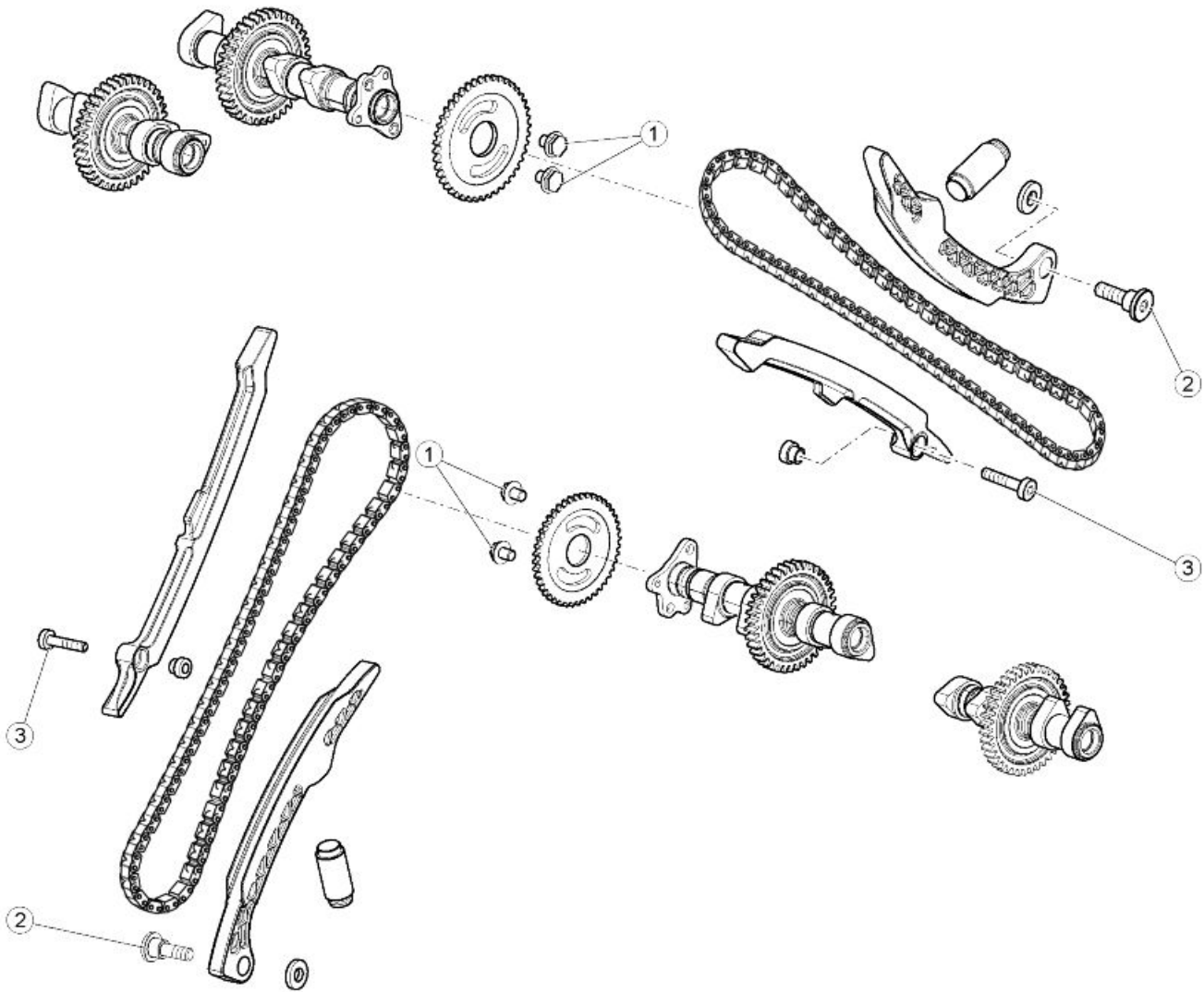
CYLINDERS - PISTON

pos.	Description	Type	Quantity	Torque	Notes
1	Screws fastening water union onto crankcase	M6x40	2	10 Nm (7.37 lbf ft)	-



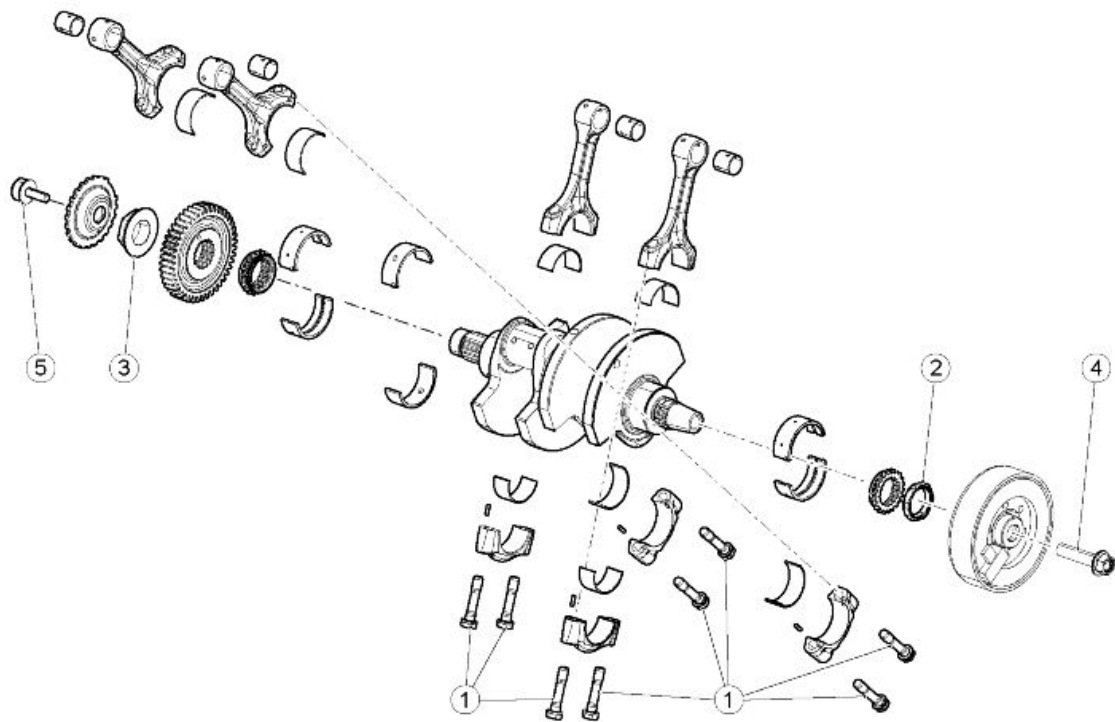
HEADS

pos.	Description	Type	Quantity	Torque	Notes
1	Exhaust stud bolts	-	8	10 Nm (7.37 lbf ft)	-
2	Camshaft cam tower fixing screws	M6x45	20	12 Nm (8.85 lbf ft)	-
3	Reed valve cover fixing screws	-	6	6 Nm (4.42 lbf ft)	-
4	Water outlet union fixing screw	-	2	12 Nm (8.85 lbf ft)	Loct. 243
5	Flanged head nut	-	12	30 + 55 Nm (22.13 + 40.56 lbf ft)	Molykote spray on thread and under head
6	Head fastener screw, chain side	M6x55	4	12 Nm (8.85 lbf ft)	-



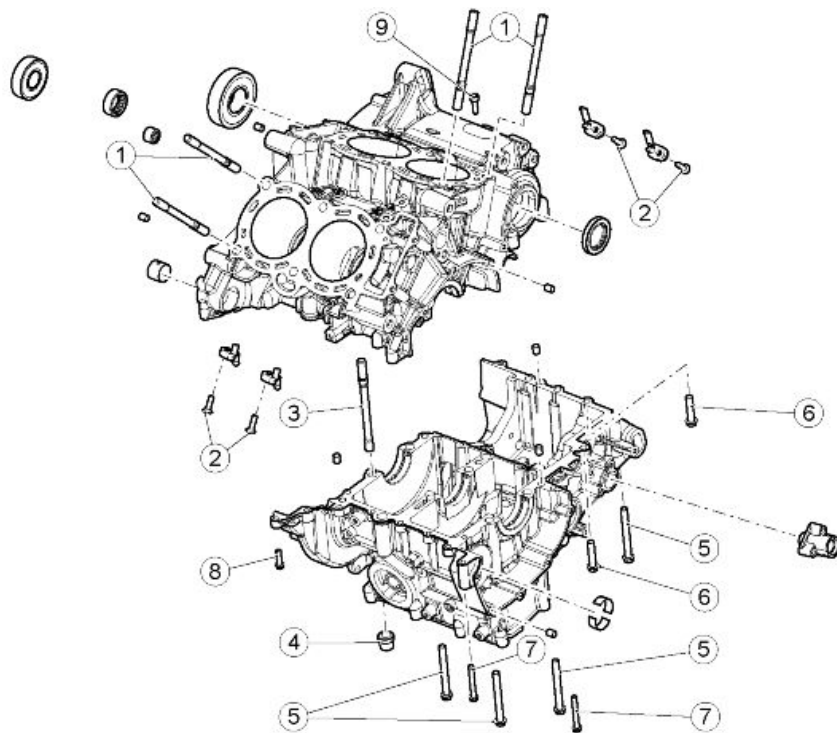
TIMING SYSTEM

pos.	Description	Type	Quantity	Torque	Notes
1	Screws fastening the timing system gear on the intake shaft	M8	4	30 Nm (22.13 lbf ft)	Loct. 243
2	Skid fastener screws	M8	2	20 Nm (14.75 lbf ft)	Loct. 243
3	Skid fastener screws	M6x18	2	10 Nm (7.37 lbf ft)	Loct. 243



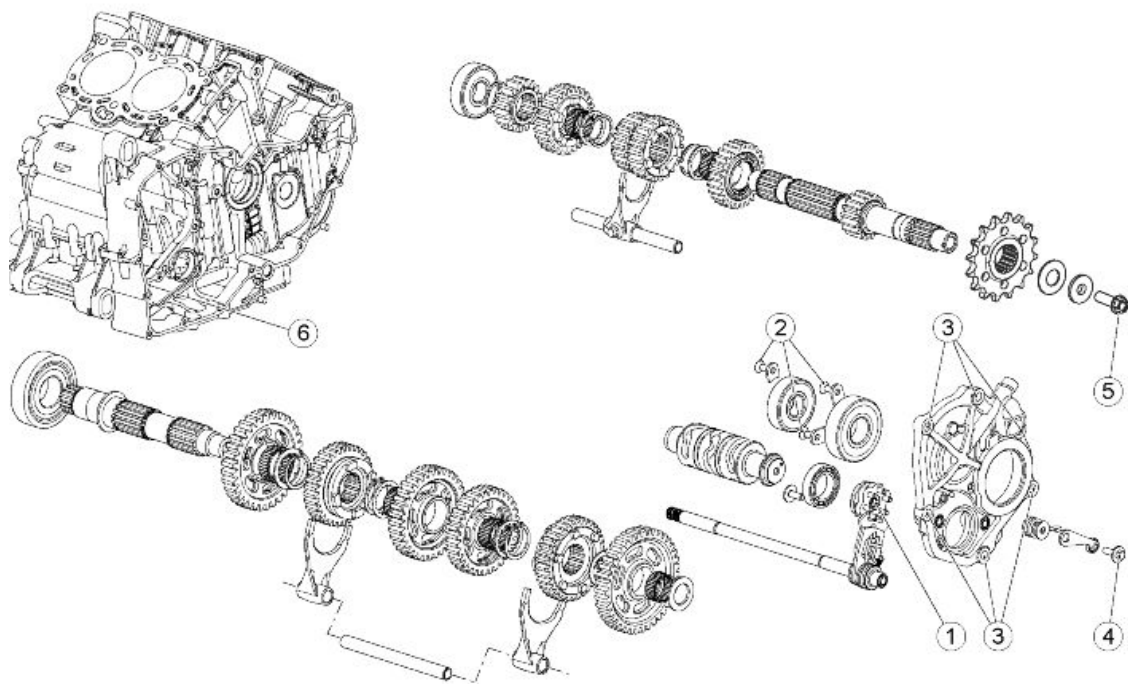
CRANKSHAFT

pos.	Description	Type	Quantity	Torque	Notes
1	Connecting rod screws	-	8	15 Nm (11.06 lbf ft) + 40° + 60°	Lubricate the thread and under the head with Molykote
2	Fastener ring nut for alternator side timing sprocket	-	1	100 Nm (73.76 lbf ft)	Loct. 243
3	Primary sprocket fixing ring nut	-	1	200 Nm (147.51 lbf ft)	Loct. 243
4	Alternator fixing screw	M12x1.25	1	120 Nm (88.51 lbf ft)	-
5	Tone wheel fixing screw	M8x1.25	1	50 Nm (36.88 lbf ft)	Loct. 3M or 270



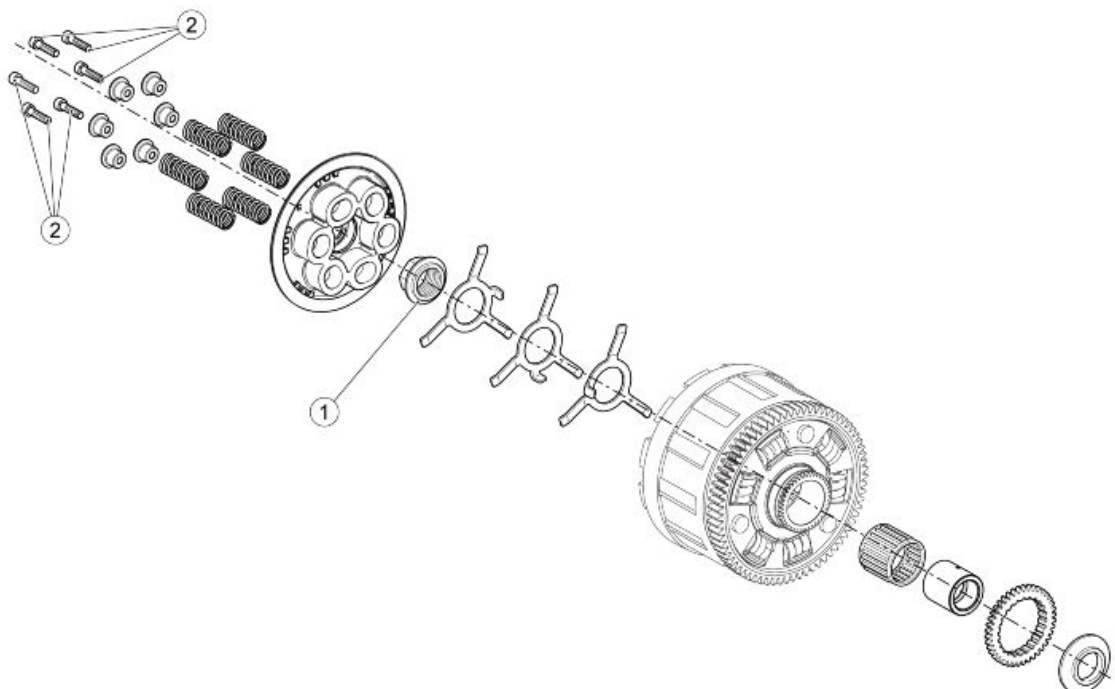
CRANKCASES

pos.	Description	Type	Quantity	Torque	Notes
1	Head stud bolts	-	12	20 Nm (14.75 lbf ft)	Loct. 648 or 270
2	Special screw for piston cooling oil jet	-	4	6 Nm (4.42 lbf ft)	Loct. 2045
3	Crankcase stud bolts	-	6	20 Nm (14.75 lbf ft)	Loct. 648 or 270
4	Main crank flanged nut	-	6	30 + 55 Nm (22.13 + 40.57 lbf ft)	Molykote - lubricate the thread and under the head
5	Crankcase fixing screw	M8x70	4	25 Nm (18.44 lbf ft)	Lubricate the thread and under the head
6	Crankcase fixing screw	M8x35	3	25 Nm (18.44 lbf ft)	Lubricate the thread and under the head
7	Crankcase fixing screw	M6x45	2	10 Nm (7.37 lbf ft)	Lubricate the thread and under the head
8	Crankcase fixing screw	M6x20	5	10 Nm (7.37 lbf ft)	Lubricate the thread and under the head
9	Crankcase fixing screw	M6x20	5	10 Nm (7.37 lbf ft)	Lubricate the thread and under the head



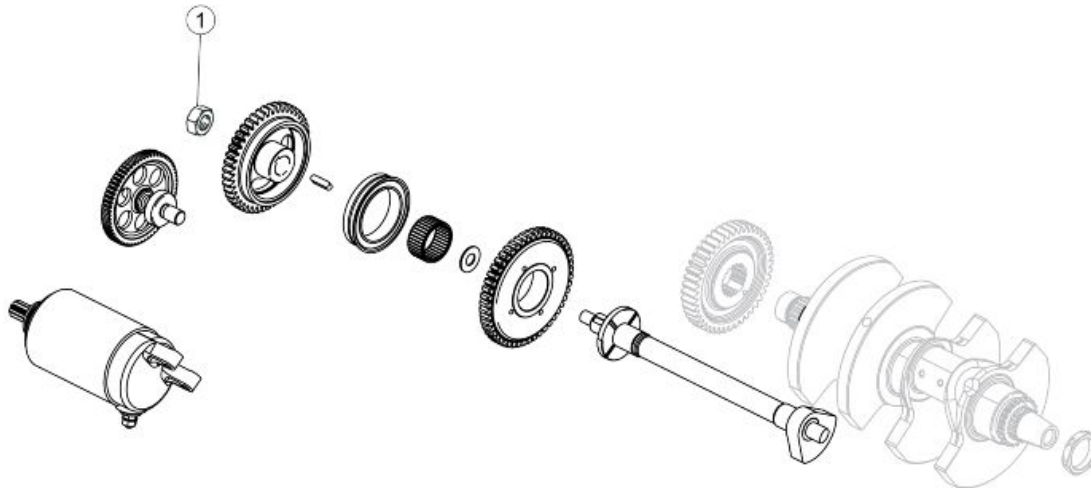
GEAR

pos.	Description	Type	Quantity	Torque	Notes
1	Connector drum fastener screw	M6x20	1	10 Nm (7.37 lbf ft)	Loct. 243
2	Bearing retainer plate fixing screw	M6x16	3	10 Nm (7.37 lbf ft)	Loct. 243
3	Flange fixing screws	M8x25	6	25 Nm (18.44 lbf ft)	-
4	Index lever fixing screw	M6	1	10 Nm (7.37 lbf ft)	Loct. 243
5	Pinion retainer	-	1	50 Nm (36.88 lbf ft)	Loct. 243
6	Screw retaining pre-selector on crankcase	-	1	25 Nm (18.44 lbf ft)	Loct. 270
-	Gear indicator fixing screw	M5x15	2	6 Nm (4.42 lbf ft)	-



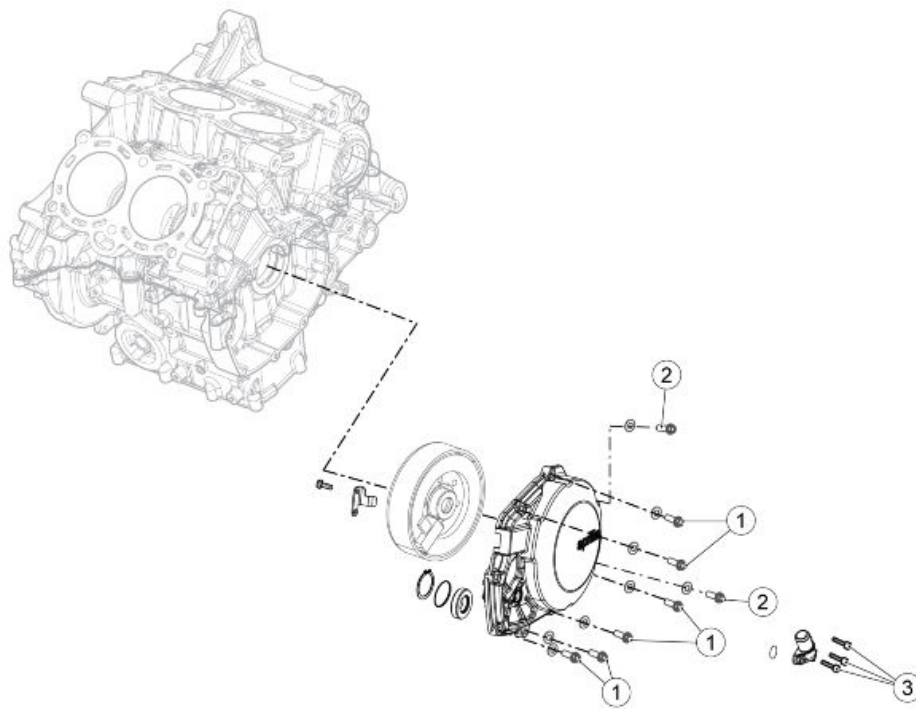
CLUTCH

pos.	Description	Type	Quantity	Torque	Notes
1	Clutch nut	-	1	150 Nm (110.63 lbf ft)	Loct. 243
2	Clutch spring fastener screw	M6	6	10 - 12 Nm (7.38 - 8.85 lbf ft)	-



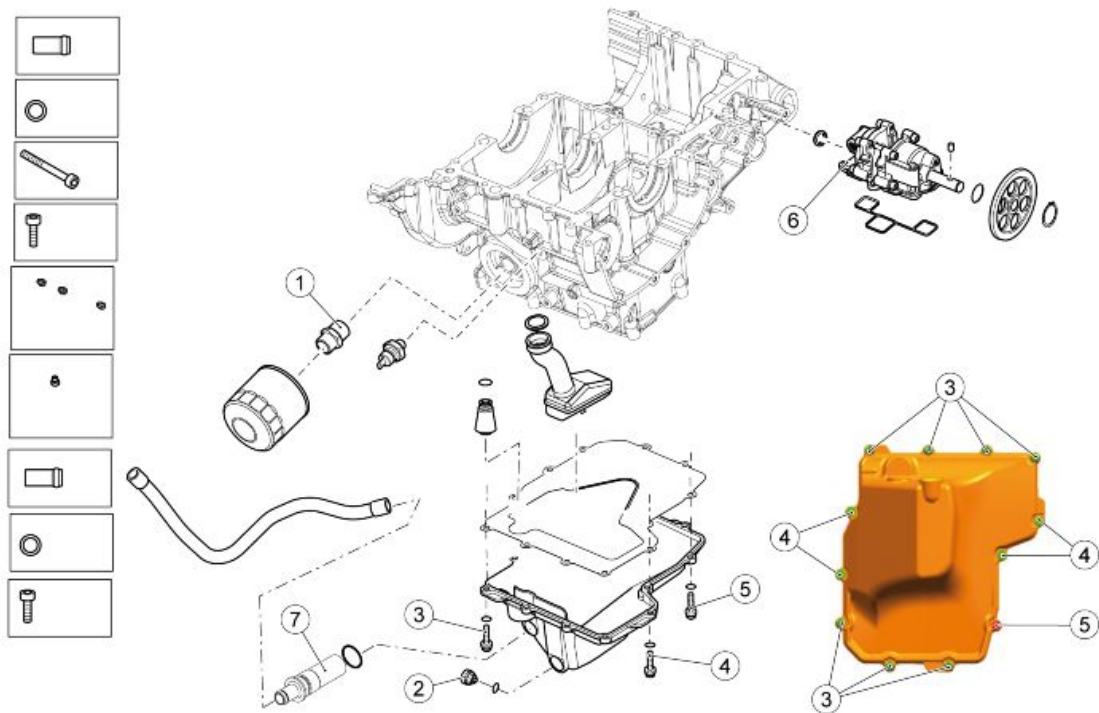
IGNITION UNIT

pos.	Description	Type	Quantity	Torque	Notes
1	Hex headed nut, cl.10 type 2 ISO 8674	M10x1	1	50 Nm (36.88 lbf ft)	Loct. 243



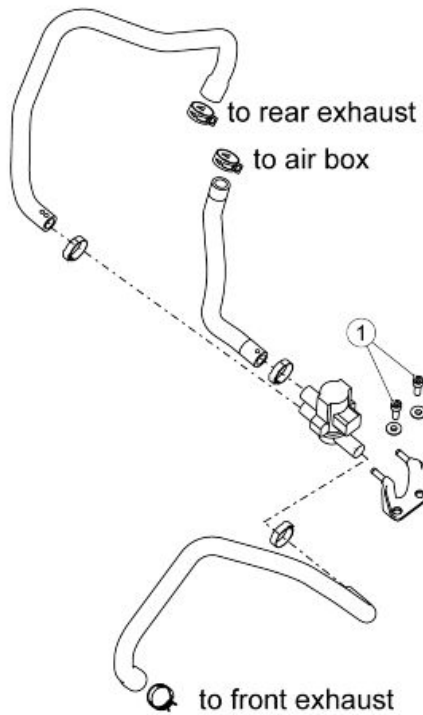
ALTERNATOR COVER

pos.	Description	Type	Quantity	Torque	Notes
1	Screws fastening cover onto centre pins	M6x25	6	12 Nm (8.85 lbf ft)	-
2	Cover fastener screws, alternator side	M6x40	2	12 Nm (8.85 lbf ft)	-
3	Blow-by union fastener screws	M5x16	3	7 Nm (5.16 lbf ft)	-
-	Stator fixing screw UNI 5931 CL8.8	M6x25	3	10 Nm (7.37 lbf ft)	Loct. 243
-	Flanged screw	M5x12	1	6 Nm (4.42 lbf ft)	Loct. 243



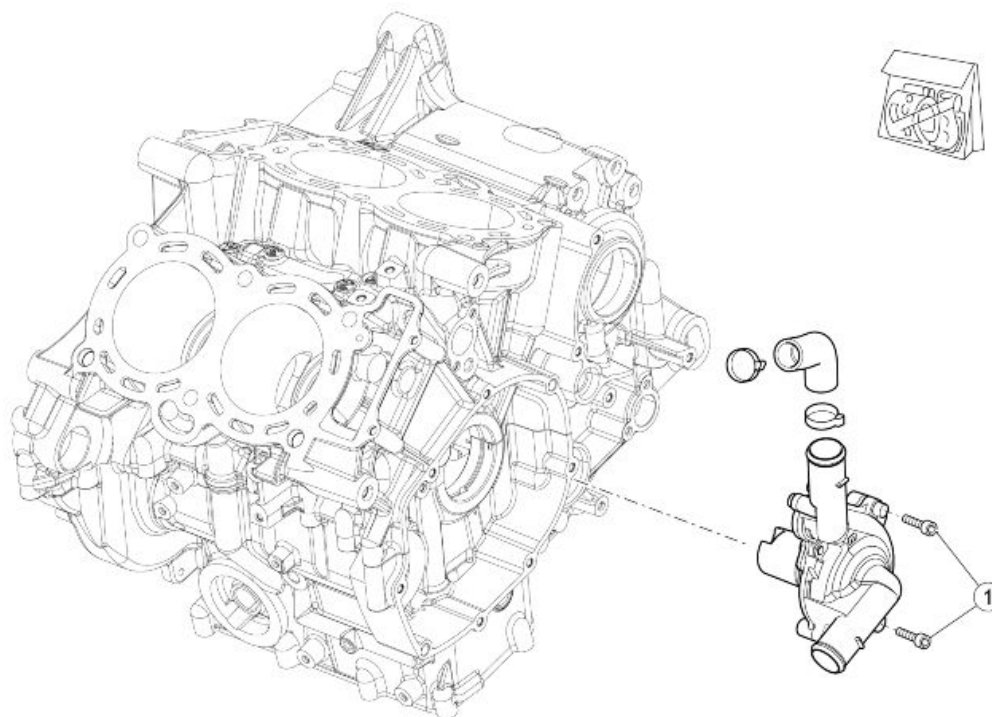
LUBRICATION

pos.	Description	Type	Quantity	Torque	Notes
1	Oil filter union fixing screw	-	1	30 Nm (22.13 lbf ft)	-
2	Oil drainage plug	-	1	30 Nm (22.12 lbf ft)	-
3	Oil sump fixing screws	M6x30	7	12 Nm (8.85 lbf ft)	-
4	Oil sump fixing screws	M6x22	4	12 Nm (8.85 lbf ft)	-
5	Oil sump fixing screws	M6x25	1	12 Nm (8.85 lbf ft)	-
6	Screws fastening the pump to the crankcase	M6	5+1	10 Nm (7.37 lbf ft)	-
7	Oil pipe union fixing screw	M6	1	8 Nm (5.90 lbf ft)	Loct. 243
-	Screw fastening the diffuser in the oil sump	-	1	10 Nm (7.37 lbf ft)	-



SECONDARY AIR SYSTEM

pos.	Description	Type	Quantity	Torque	Notes
1	Secondary air system solenoid screws	-	2	10 Nm (7.37 lbf ft)	-



WATER PUMP

pos.	Description	Type	Quantity	Torque	Notes
1	Screws fastening the pump to the crankcase	M6x25	2	10 Nm (7.37 lbf ft)	-

Recommended products chart

RECOMMENDED PRODUCTS TABLE

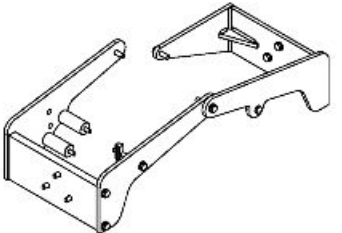
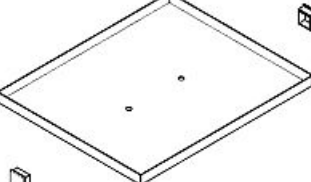


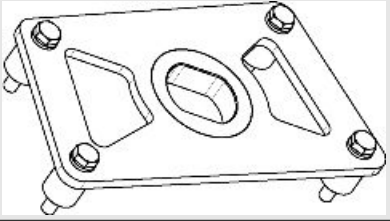
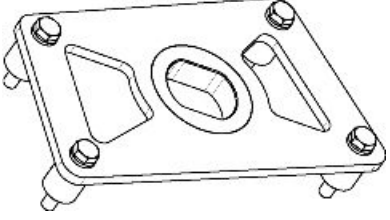
Product	Description	Specifications
ENI i-RIDE APRILIA RACING 5W-40	Engine oil	Use branded oils with performance equivalent to or exceeding ACEA A3 - API SL - JASO MA - JASO MA2 specifications
AGIP MP GREASE	Black smooth textured lithium-calcium soap based grease containing EP (extreme pressure) additives with optimal water-repellent properties	ISO L-X-BCHB 2 - DIN 51 825 KP2K-20
AGIP PERMANENT SPECIAL	Ethylene glycol-based antifreeze fluid with organic inhibition additives. Red, ready for use	ASTM D 3306 - ASTM D 4656 - ASTM D 4985 - CUNA NC 956-16
AGIP BRAKE 4	Brake fluid	SAE J 1703 - FMVSS 116 - DOT 3/4 - ISO 4925 - CUNA NC 956 DOT 4 synthetic fluid
AGIP FORK 7.5W	Fork oil (Showa)	SAE 7.5W
AGIP ARNICA SA 32	Fork oil (Sachs)	SAE 0W - ISO VG 32

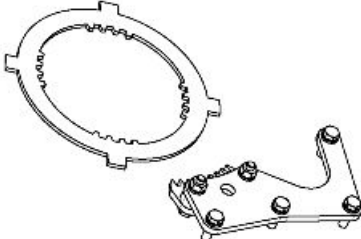
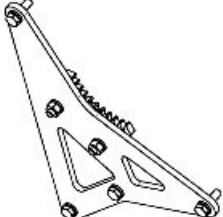
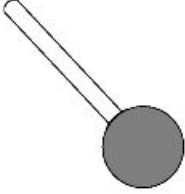
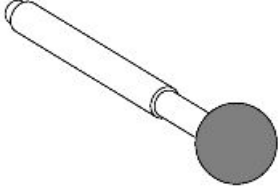
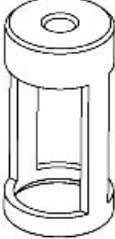
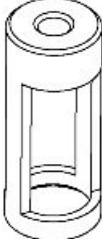
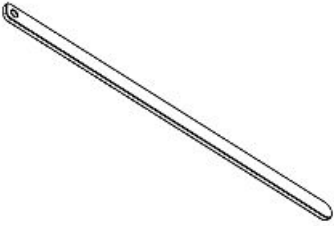
INDEX OF TOPICS

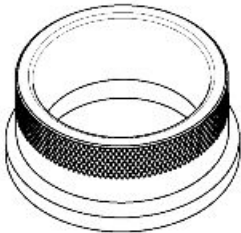
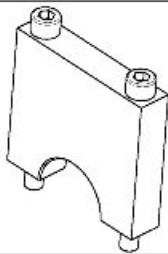
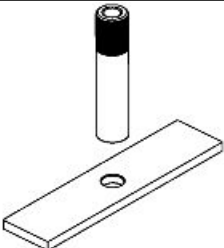

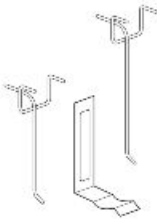
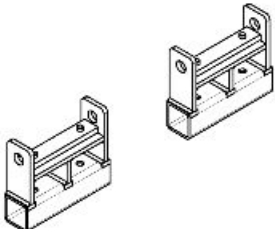
SSPECIAL TOOLS



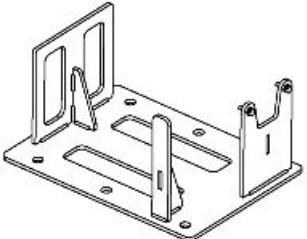
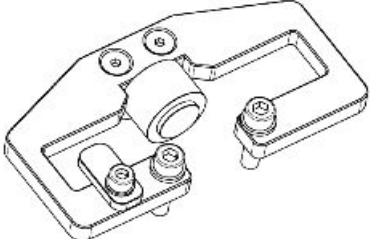
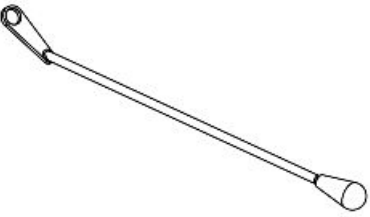
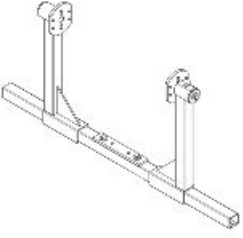
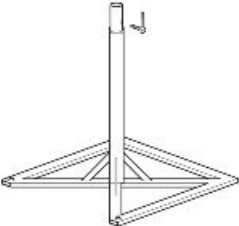
S-TOOLS




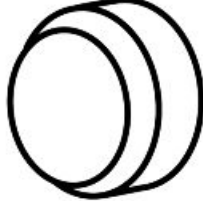

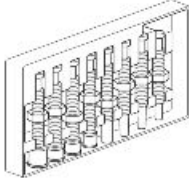
SPECIAL TOOLS

Stores code	Description	
020845Y	Engine support	
020846Y	Retaining tray + plastic caps	
020847Y	Flywheel extractor (Mitsubishi)	
020913Y	Flywheel extractor (Kokusun)	
020848Y	Flywheel retainer (Mitsubishi)	
020914Y	Flywheel retainer	

Stores code	Description	
020849Y	Clutch retainer	
020850Y	Primary gear lock	
020851Y	Camshaft timing pin	
020852Y	Crankshaft timing pin	
020853Y	Intake valve spring compressor	
020854Y	Exhaust valve spring compressor	
020855Y	Lever for engaging the chain tensioner	

Stores code	Description	
020856Y	Piston installation ring	
020857Y	Crankshaft bearing U bolt	
020858Y	Device for holding the pistons in the cylinders	
AP8140199	Tool panel	
020859Y	Panel graphics	
8140426	Hooks for panel	
020860Y	Engine support extension	

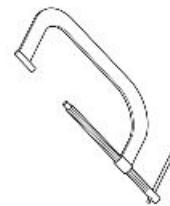
Stores code	Description	
020862Y	Gearbox control rod roller cage fitting punch	
020863Y	Desmodromic drum roller cage fitting punch	
020864Y	Engine mounting plate	
020865Y	Support for camshaft gear on head	
020883Y	Tool for fitting/removing the timing chain tensioner	
020709Y	Engine support	
AP8140187	Engine support stand	

Stores code	Description	
020376Y	Adapter handle	
020363Y	20-mm Oil seal guide	
020364Y	25-mm Guide	
020359Y	42 x 47 mm punch	
020431Y	Valve oil seal extractor	
AP8140180	Extractor for bushings	

Stores code	Description
-------------	-------------

AP8140179

Valve spring compressor



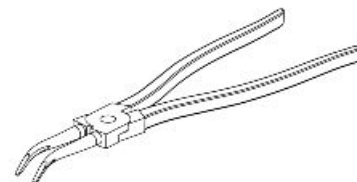
0277308

Guide bushing for secondary gearbox shaft



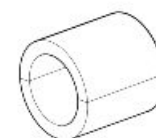
020877Y

Pliers for clamps



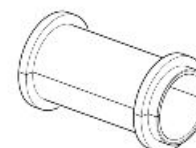
AP8140146

Weight



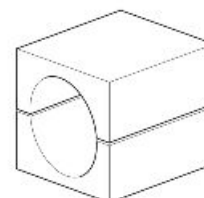
AP8140189

Oil seal fitting tool for Ø 43 mm (1.69 in) orifices



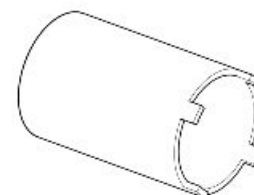
AP8140149

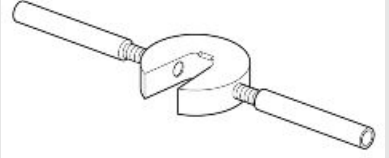
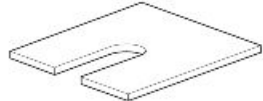
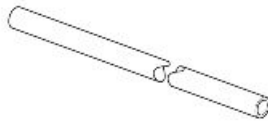
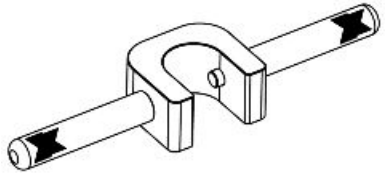



Protection for fitting operations



AP8140190

Tool for steering tightening



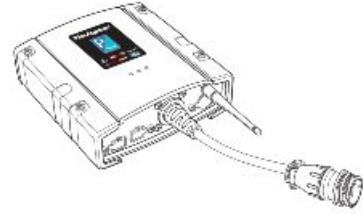
Stores code	Description	
AP8140147	Spacer tool	
AP8140148	Spacer-piston separating plate	
AP8140150	Perforated rod for piston air bleed	
020888Y	Pliers for pre-fill pipe	
020889Y	Piston ring nut locking spanner	
020890Y	Piston stanchion support rod	
AP8140181	Fuel pressure checking tool	

Stores code

020680Y

Description

TXB Navigator



INDEX OF TOPICS

MAINTENANCE

MAIN

Maintenance chart

Correct maintenance is fundamental for ensuring the longevity of your vehicle and maintaining optimum function and performance.

To this end, Aprilia offers a set of checks and maintenance services (at the owner's expense), that are summarised in the table shown on the following page. Any minor faults must be reported without delay to an **Authorised Aprilia Dealer or Sub-Dealer** without waiting until the next scheduled service to solve it.

All scheduled services must be carried out at the specified intervals and mileage, as soon as the pre-determined mileage is reached. Carrying out scheduled services on time is essential for the validity of your warranty. For further information regarding Warranty procedures and "Scheduled Maintenance", please refer to the "Warranty Booklet".

NOTE

CARRY OUT MAINTENANCE OPERATIONS AT HALF THE INTERVALS SPECIFIED IF THE VEHICLE IS USED IN PARTICULAR RAINY OR DUSTY CONDITIONS, OFF ROAD OR FOR TRACK USE.

NOTE

THE TIMES LISTED ON THE SCHEDULED MAINTENANCE TABLE INCLUDE TIME DEDICATED TO MANAGEMENT ACTIVITIES.

I: INSPECT AND CLEAN, ADJUST, LUBRICATE OR REPLACE IF NECESSARY

C: CLEAN, R: REPLACE, A: ADJUST, L: LUBRICATE

- (1) Check at each engine start
- (2) Check and clean and adjust or replace, if necessary, before every journey.
- (3) Check and clean and adjust or replace, if necessary, every 1000 Km (621 mi)
- (4) Replace every 2 years
- (5) Replace every 4 years
- (6) Every 5000 Km (3107 mi) if the vehicle is used for racing
- (7) Every 10000 Km (6213 mi) if the vehicle is used for racing
- (8) Check and clean every 10000 Km (6213 mi) if the vehicle is used for racing
- (9) Replace when reaching the first of the following two options: 40000 km (24854 mi) or 48 months

ROUTINE MAINTENANCE TABLE

km x 1000	1	10	20	30	40
Rear shock absorber (6)			I		I
Set up (6)	I	I	I	I	I
Cylinder equalisation			I		I
Spark plug (6) (8)			R		R
Drive chain (3)	I - L	I - L	I - L	I - L	I - L
Clutch cable	L	L	L	L	L
Control cables and controls (6)	I	I	I	I	I
Sprocket - pinion (6)		I	I	I	I
Rear suspension bearings - linkages			I		I
Steering bearings and steering clearance (6)		I	I	I	I
Wheel bearings (6)		I	I	I	I
Control unit diagnosis		I	I	I	I
Brake discs (6)	I	I	I	I	I

km x 1000	1	10	20	30	40
Air filter (6)			R		R
Engine oil filter (6)	R	R	R	R	R
Fork					
General vehicle operation (6)					
Valve clearance (7)			A		A
Cooling system (6)					
Brake systems (6)					
Light circuit					
Stand switch					
Safety switches					
Stop switches					
Brake fluid (4)					
Coolant (4)					
Fork oil (7)(9)					R
Engine oil (6)	R	R	R	R	R
Light aiming					
Fork oil seals (6)					
Flexible coupling					
Tyres - pressure/wear (2)					
Wheels (6)					
Tightening torques (6)					
Tightening of clutch cover, flywheel and oil sump screws					
Fault warning light on instrument panel (1)					
Fuel lines (5)					
Clutch wear (7)					
Brake pad wear (2)					
Labour time (minutes)	110	160	410	160	650

Spark plug

FRONT SPARK PLUGS

- Remove the base of the air filter box.
- Undo and remove the screw.



- Slide off the front coil.



- Unscrew and remove the front spark plug.

REAR SPARK PLUGS

- Remove the fuel tank.
- Unscrew and remove the rear coil fastener screw.
- Slide off the rear coil.
- Unscrew and slide off the rear spark plug.



Engine oil

Check

NOTE

HOT OIL IS MORE FLUID AND WILL DRAIN OUT MORE EASILY AND COMPLETELY.

- Shut off the engine and wait for a few seconds.
- Keep the vehicle upright with both wheels on the ground.
- Ensure that the vehicle is on a level surface.
- Check, via the sight glass positioned on the clutch casing, that the oil level reaches at least three quarters of the way up the sight glass itself.



- If this is not the case, top-up the oil immediately through the filler plug.

CAUTION

NEVER ALLOW THE OIL LEVEL TO DROP BELOW THE MINIMUM LEVEL OR FILL ABOVE THE MAXIMUM LEVEL; IF YOU DO NOT COMPLY WITH THE MINIMUM AND MAXIMUM OIL LEVELS THE ENGINE COULD BE SERIOUSLY DAMAGED



Replacement

NOTE

HOT OIL IS MORE FLUID AND WILL DRAIN OUT MORE EASILY AND COMPLETELY.

- Place a container with suitable capacity under the drainage plug.
- Unscrew and remove the drainage plug.



- Unscrew and remove the filler cap.
- Drain the oil into the container; allow several minutes for oil to drain out completely.
- Check and, if necessary, replace the drainage plug sealing washers.
- Screw and tighten the drainage plug.
- Add 4 l (0.88 UK gal) of new engine oil of the specified type.
- Screw on the filler cap.



- Warm up the engine up by running it for a few minutes, then switch it off. After thirty seconds, check the level in the sight glass. Top up if necessary.

CAUTION

NEVER ALLOW THE OIL LEVEL TO DROP BELOW THE MINIMUM LEVEL OR FILL ABOVE THE MAXIMUM LEVEL; IF YOU DO NOT COMPLY WITH THE MINIMUM AND MAXIMUM OIL LEVELS THE ENGINE COULD BE SERIOUSLY DAMAGED



Engine oil filter

Replace the engine oil filter each time you change the engine oil.

- Drain the engine oil completely.
- Unscrew and remove the engine oil filter from its seat.

NOTE

NEVER REUSE AN OLD FILTER.



- Spread a thin layer of oil on the sealing ring of the new engine oil filter.
- Insert and screw the new engine oil filter in the seat, filling the filter to 1/3 of its capacity with engine oil before fitting.

See also

[Replacement](#)

Air filter

- Remove the fuel tank.
- Unscrew and remove the eight air filter box cover screws



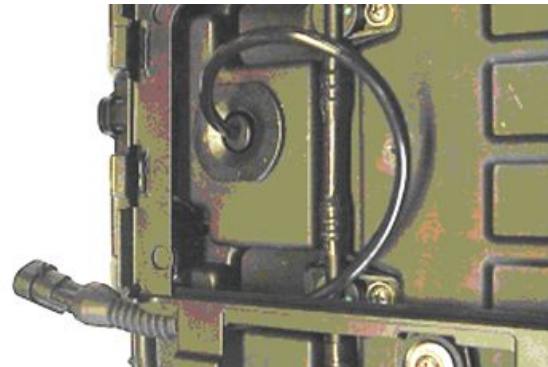
- Disconnect the upper injector fuel delivery union.



See also

Fuel tank

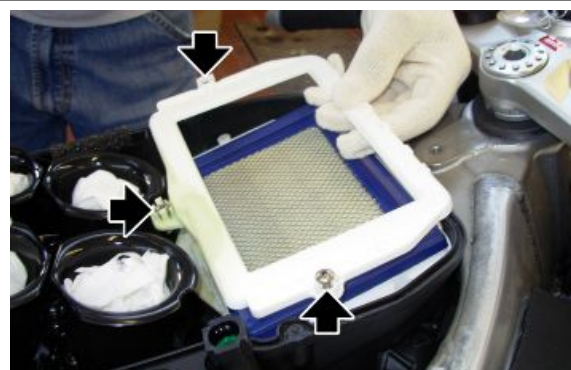
- Disconnect the variable geometry intake system connector. (If connected)



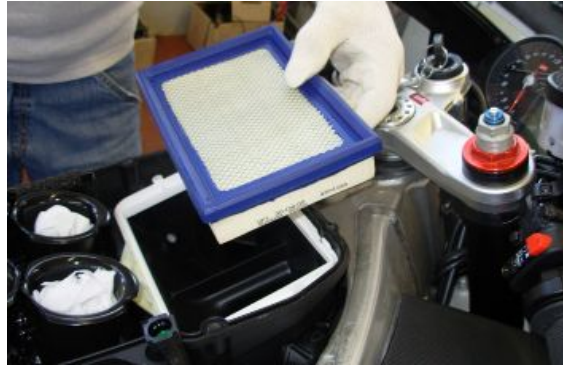
- Fit a suitably sized shim behind the filter box cover.
- Lift the filter box cover on which the control unit is installed.
- Do not rotate the cover excessively to avoid straining the pipes and cables.
- Plug the intake duct opening with clean paper



- Undo and remove the three air filter screws.
- Remove the filter lock.



- Remove the air filter.



Checking the valve clearance

FRONT HEAD

- Remove both throttle bodies and the coils.
- Remove the front head cover and the spark plugs.
- Remove the cap on the clutch cover in order to turn the crankshaft, taking care not to lose the O-ring.



See also

[Removing the throttle body](#)

Spark plug

Head cover removal

- Use a feeler gauge to check the clearance between the cam of the shaft and the relative tappet for both front head shafts.

Characteristic

Acceptable values with control clearance between cam and valve

Intake: 0.10 - 0.15 mm (0.0039 - 0.0059 in) ex-

haust: 0.20 - 0.25 mm (0.0079 - 0.0098 in)





REAR HEAD

- Remove both throttle bodies and the spark plugs.
- Remove the rear head cover.

See also

[Removing the throttle body](#)

Spark plug

Head cover removal

-
- Use a feeler gauge to check the clearance between the cam on the shaft and the relative tappet for both rear head shafts.

Characteristic

Acceptable values with control clearance between cam and valve

Intake: 0.10 - 0.15 mm (0.0039 - 0.0059 in) exhaust: 0.20 - 0.25 mm (0.0079 - 0.0098 in)



Front cylinder head valves

- Check the front valve head clearance and restore the correct clearance values if necessary, proceeding as described below.
- Remove both head covers, the alternator side cover and remove the cap on the clutch cover in order to rotate the crankshaft.
- Remove the O ring.



See also

Head cover removal

[Removing the flywheel cover](#)

- Turn the crankshaft from the hole on the clutch cover.
- Move cylinder piston 1 (left rear piston) to the TDC overlap;
- Turn the crankshaft 150° in the direction of engine rotation (direction of travel).



- Insert the pin from the flywheel side, in the hole in the crankshaft.

NOTE

THE SPECIAL TOOL IS ONLY USED FOR IDENTIFYING THE CORRECT CRANKSHAFT POSITION.
DO NOT USE IT FOR TIGHTENING OPERATIONS.

Specific tooling

020852Y Crankshaft timing pin



- Fit the pin for aligning the intake camshaft with the hole on U-bolt.
- If it was not possible before adjusting the valve clearance, check the engine timing.



Specific tooling

020851Y Camshaft timing pin

- Remove the two crankshaft and camshaft reference pins.
- Turn the crankshaft until the gear screw covered by the head when the hole on the camshaft gear is aligned with the hole on the U bolt, is visible.
- Block crankshaft rotation using one of the specific tools.
- Unscrew and remove the camshaft gear screw.
- Remove the crankshaft locking tool.



Specific tooling

020850Y Primary gear lock

020848Y Flywheel retainer

Repeat the following operations:

- move cylinder piston 1 (left rear piston) to TDC;
- turn the crankshaft 150° in the direction of engine rotation (direction of travel) in order to align the hole on the intake camshaft with the specific hole on the U bolt; this ensures that all the front cylinder bank valve springs are decompressed.
- Refit the camshaft timing setting pin in the hole in the U bolt on the front head, and refit the crankshaft timing pin from the flywheel side, to check that the tim-



ing setting was not altered while the engine was turned with only one camshaft drive gear fastener screw in place.

- Remove the camshaft timing pin.
- Unscrew and remove the two U bolt screws (1).
- Remove the U bolt and the oil pipe.

Specific tooling

020851Y Camshaft timing pin

020852Y Crankshaft timing pin

- Block crankshaft rotation using one of the specific tools.
- Unscrew and remove the second intake camshaft gear screw.
- Leave the gear on the camshaft.

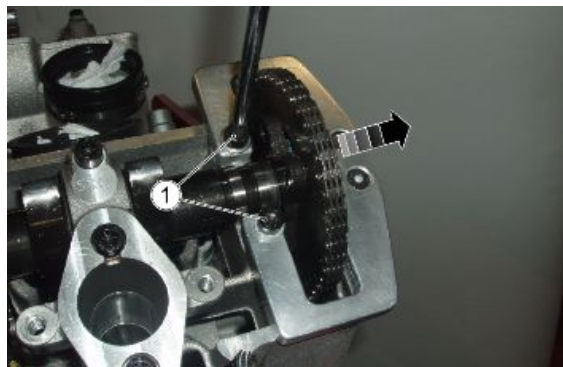


Specific tooling

020848Y Flywheel retainer

020850Y Primary gear lock

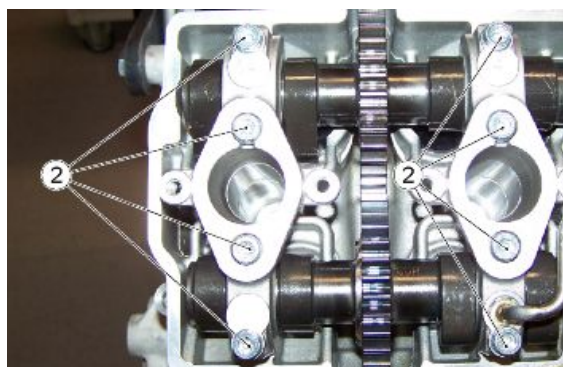
- Install the specific camshaft gear support tool.
- Fix it to the head using the two screws (1).
- Move the gear from the camshaft to the tool.



Specific tooling

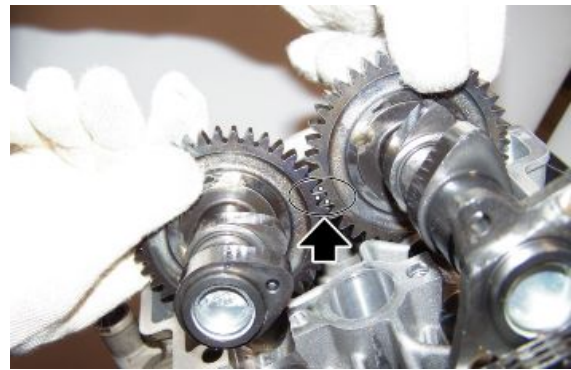
020865Y Support for camshaft gear on head

- Unscrew and remove the eight screws (2), proceeding in stages and diagonally.
- Retrieve the washers from the screws near the spark plug holes.
- Remove the U bolts with the O rings and locator pins.



- Remove the intake and exhaust camshafts.

If the two camshafts are timed correctly, the exhaust camshaft gear tooth (indicated with a dot) is meshed with the trough of the intake camshaft gear (indicated with two dots).



- Use a magnet to remove the tappet.

CAUTION

REMOVE THE TAPPET CAREFULLY AS THE PAD MAY FALL INTO THE ENGINE.

- Retrieve the pad and replace with a suitable component to achieve the correct valve clearance.

Refer to the table: "Calibrated pad thicknesses" to identify the suitable thickness.

- Fit the tappet.



See also

[Calibrated pad thickness](#)

NOTE

Engines up to engine No. V4 2470 are equipped with conventional exhaust camshaft gears, while engines from engine No. V4 2471, are equipped with self-adjusting exhaust camshaft gears.

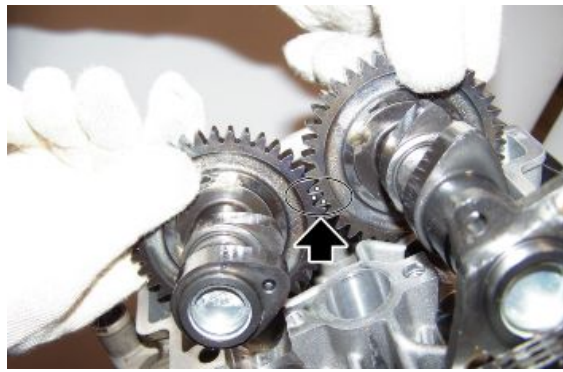


- Install the intake and exhaust camshafts on the front head, bearing in mind that:

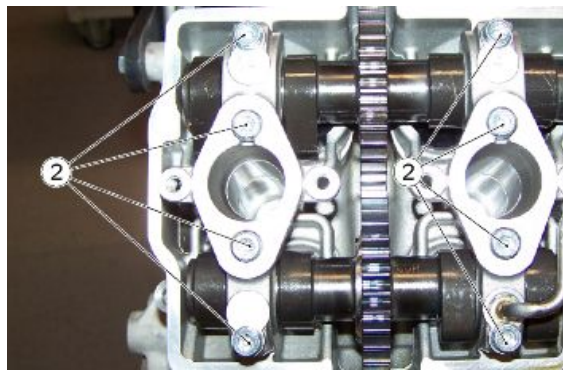
the exhaust camshaft gear tooth (indicated with a dot) is meshed with the trough of the intake camshaft gear (indicated with two dots).



CLEAN THOROUGHLY THE SEATS OF THE GEAR RETAINER SCREWS, ON THE INTAKE CAMSHAFT.



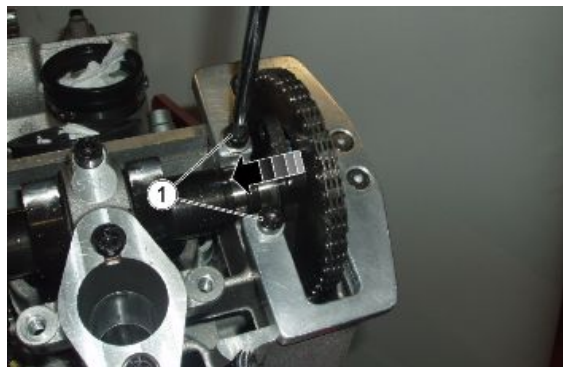
- Fit the U bolts with the nine O rings and locator pins.
- Fit the new washers under the screws (2) near the spark plug holes only.
- Tighten the seven screws (2) operating in stages and diagonally.
- Do not fit the eighth screw (2 - fastening the oil pipe) yet.



- Move the gear from the mounting tool to the camshaft.
- Unscrew and remove the two screws (1).
- Remove the tool.

Specific tooling

020865Y Support for camshaft gear on head



- Fit the U bolt and the oil pipe.
- Tighten the two U bolt screws (1) and the screw (2) that was not fitted previously.



- Align the intake camshaft with the specific hole on the U bolt.
- Insert the specified pin.

Specific tooling

020851Y Camshaft timing pin



- Apply Loctite 243 thread lock on the thread of the timing gear fastener screw. This screw must be replaced at each reassembly.
- Apply and loosely tighten the gear fixing screw on the camshaft.



- Block crankshaft rotation using one of the specific tools.
- Tighten the gear fixing screw on the camshaft to exactly the torque specified.
- Remove the crankshaft locking tool.



Specific tooling

020848Y Flywheel retainer

020850Y Primary gear lock

- Remove the two crankshaft and camshaft reference pins.
- Turn the crankshaft until the gear screw covered by the head when the hole on the camshaft gear is aligned with the hole on the U bolt, is visible.
- Block crankshaft rotation using one of the specific tools.
- Apply Loctite 243 thread lock on the thread of the second gear fastener screw. This screw must be replaced at each reassembly.



- Tighten the second camshaft gear fixing screw to exactly the torque specified.
- Remove the crankshaft locking tool.

Specific tooling

020848Y Flywheel retainer

020850Y Primary gear lock

020851Y Camshaft timing pin

020852Y Crankshaft timing pin

- Turn the crankshaft back to the previous position in which the camshaft and U bolt holes were aligned; insert the reference pin while checking with the crankshaft reference pin, that the flywheel side hole and the hole on the crankshaft are perfectly aligned.
- If this is not the case, repeat the timing operations.

Specific tooling

020851Y Camshaft timing pin

020852Y Crankshaft timing pin

- Check if the clearance between the cam on the shaft and the tappet is correct.
- If not, repeat the valve clearance adjustment procedure.

Rear cylinder head valves

- Check the rear valve head clearance and restore the correct clearance values if necessary, proceeding as described below.
- Remove the rear head cover and the clutch cover.
- Move cylinder piston 1 (left rear piston) to the TDC;
- Turn the crankshaft 450° (one complete turn + 90°) in the direction of motor rotation (direction of travel).
- Insert the pin from the clutch side into the hole in the crankshaft.

NOTE

THE SPECIAL TOOL IS ONLY USED FOR IDENTIFYING THE CORRECT CRANKSHAFT POSITION. DO NOT USE IT FOR TIGHTENING OPERATIONS.

Specific tooling

020852Y Crankshaft timing pin



See also

Head cover removal

Removing the clutch cover

- Fit the pin for aligning the intake camshaft with the hole on U-bolt.
- If it was not possible before adjusting the valve clearance, check the engine timing.

Specific tooling

020851Y Camshaft timing pin



- Remove the two crankshaft and camshaft reference pins.
- Turn the crankshaft until the gear screw covered by the head when the hole on the camshaft gear is aligned with the hole on the U bolt, is visible.
- Block crankshaft rotation using one of the specific tools.
- Unscrew and remove the camshaft gear screw.
- Remove the crankshaft locking tool.



Specific tooling

020850Y Primary gear lock

020848Y Flywheel retainer

Repeat the following operations:

- move cylinder piston 1 (left rear piston) to TDC;
- turn the crankshaft by 450° (one complete turn + 90°) in the direction of engine rotation (direction of travel) to align the hole on the intake camshaft with the specific hole on the U bolt. This ensures that all the rear cylinder bank valve springs are decompressed.
- Refit the camshaft timing setting pin in the hole in the U bolt on the rear head,



and refit the crankshaft timing pin from the clutch side, to check that the timing setting was not altered while the engine was turned with only one camshaft drive gear fastener screw in place.

- Remove the camshaft timing pin.
- Unscrew and remove the two U bolt screws (1).
- Remove the U bolt and the oil pipe.

Specific tooling

020851Y Camshaft timing pin

020852Y Crankshaft timing pin

- Block crankshaft rotation using one of the specific tools.
- Unscrew and remove the second intake camshaft gear screw.
- Leave the gear on the camshaft.

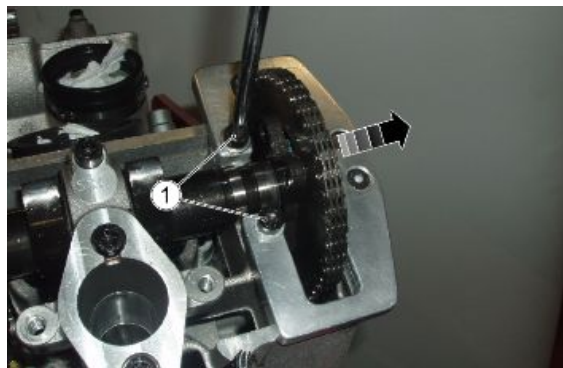


Specific tooling

020848Y Flywheel retainer

020850Y Primary gear lock

- Install the specific camshaft gear support tool.
- Fix it to the head using the two screws (1).
- Move the gear from the camshaft to the tool.



Specific tooling

020865Y Support for camshaft gear on head

- Unscrew and remove the eight screws (2), proceeding in stages and diagonally.
- Retrieve the washers from the screws near the spark plug holes.
- Remove the U bolts with the O rings and locator pins.



- Remove the intake and exhaust camshafts.

If the two camshafts are timed correctly, the intake camshaft gear tooth (indicated with one dot) is meshed with the trough of the exhaust camshaft gear (indicated with two dots).



- Use a magnet to remove the tappet.

CAUTION

REMOVE THE TAPPET CAREFULLY AS THE PAD MAY FALL INTO THE ENGINE.

- Retrieve the pad and replace with a suitable component to achieve the correct valve clearance.

Refer to the table: "Calibrated pad thicknesses" to identify the suitable thickness.

- Fit the tappet.



See also

[Calibrated pad thickness](#)

NOTE

Engines up to engine No. V4 2470 are equipped with conventional exhaust camshaft gears, while engines from engine No. V4 2471, are equipped with self-adjusting exhaust camshaft gears.

- Install the intake and exhaust camshafts on the rear head, remembering that:

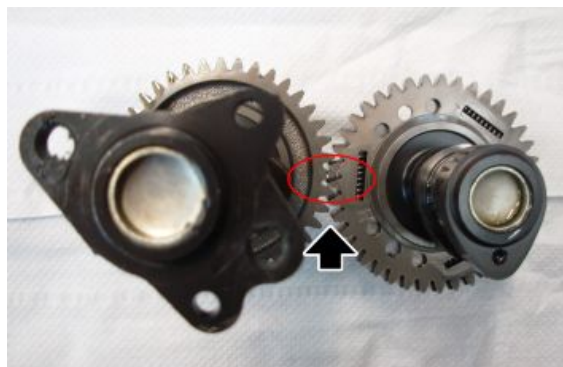
the intake camshaft gear tooth (indicated with a dot) is inserted in the groove of the exhaust camshaft gear (indicated with two dots).



CLEAN THOROUGHLY THE SEATS OF THE GEAR RETAINER SCREWS, ON THE INTAKE CAMSHAFT.



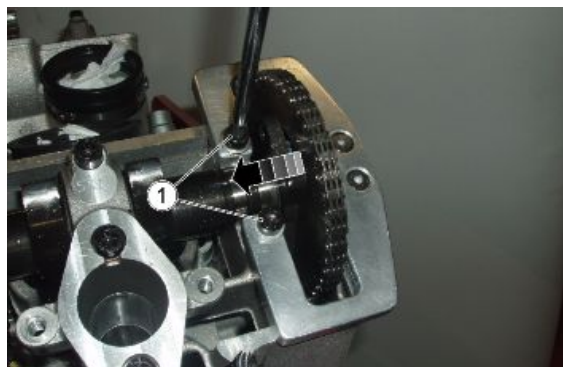
- Fit the U bolts with the nine O rings and locator pins.
- Fit the new washers under the screws (2) near the spark plug holes only.
- Tighten the seven screws (2) operating in stages and diagonally.
- Do not fit the eighth screw (2 - fastening the oil pipe) yet.



- Move the gear from the mounting tool to the camshaft.
- Unscrew and remove the two screws (1).
- Remove the tool.

Specific tooling

020865Y Support for camshaft gear on head



- Fit the U bolt and the oil pipe.
- Tighten the two U bolt screws (1) and the screw (2) that was not fitted previously.



- Align the intake camshaft with the specific hole on the U bolt.
- Insert the specified pin.

Specific tooling

020851Y Camshaft timing pin



- Apply Loctite 243 thread lock on the thread of the timing gear fastener screw. This screw must be replaced at each reassembly.
- Apply and loosely tighten the gear fixing screw on the camshaft.



- Block crankshaft rotation using one of the specific tools.
- Tighten the gear fixing screw on the camshaft to exactly the torque specified.
- Remove the crankshaft locking tool.

Specific tooling

020848Y Flywheel retainer

020850Y Primary gear lock



- Remove the two crankshaft and camshaft reference pins.
- Turn the crankshaft until the gear screw covered by the head when the hole on the camshaft gear is aligned with the hole on the U bolt, is visible.
- Block crankshaft rotation using one of the specific tools.
- Apply Loctite 243 thread lock on the thread of the second gear fastener screw. This screw must be replaced at each reassembly.
- Tighten the second camshaft gear fixing screw to exactly the torque specified.
- Remove the crankshaft locking tool.



Specific tooling

020848Y Flywheel retainer

020850Y Primary gear lock

020851Y Camshaft timing pin

020852Y Crankshaft timing pin

- Turn the crankshaft back to the previous position in which the camshaft and U bolt holes were aligned; Refit the reference pin while checking, using the crankshaft reference pin, that the clutch side hole and the hole in the crankshaft are perfectly aligned.
- If this is not the case, repeat the timing operations.

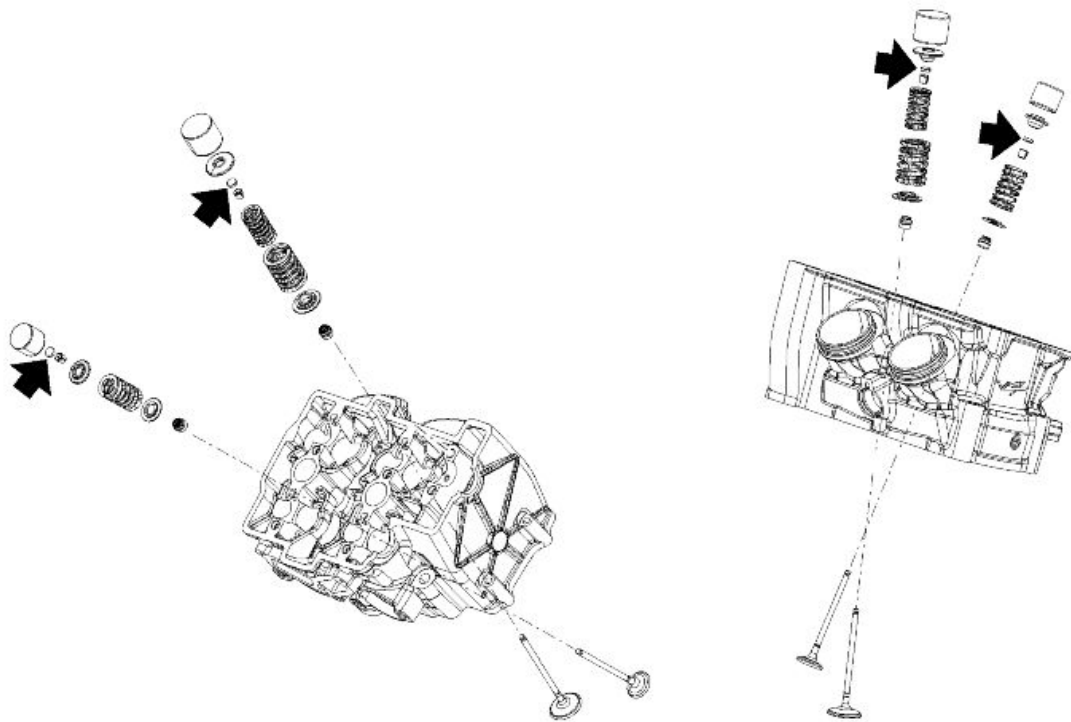
Specific tooling

020851Y Camshaft timing pin

020852Y Crankshaft timing pin

- Check if the clearance between the cam on the shaft and the tappet is correct.
- If not, repeat the valve clearance adjustment procedure.

Calibrated pad thickness



Pad thicknesses for adjusting valve clearance correctly:

- 1.75 mm (0.0689 in)
- 1.77 mm (0.0697 in)
- 1.80 mm (0.0709 in)
- 1.82 mm (0.0716 in)
- 1.85 mm (0.0728 in)
- 1.87 mm (0.0736 in)
- 1.90 mm (0.0748 in)
- 1.92 mm (0.0756 in)
- 1.95 mm (0.0768 in)
- 1.97 mm (0.0775 in)
- 2 mm (0.0787 in)
- 2.02 mm (0.0795 in)
- 2.05 mm (0.0807 in)
- 2.07 mm (0.0815 in)
- 2.1 mm (0.0827 in)
- 2.12 mm (0.0835 in)
- 2.15 mm (0.0846 in)
- 2.17 mm (0.0854 in)
- 2.2 mm (0.0866 in)
- 2.22 mm (0.0874 in)

2.25 mm (0.0886 in)
2.27 mm (0.0894 in)
2.3 mm (0.0905 in)
2.32 mm (0.0913 in)
2.35 mm (0.0925 in)
2.37 mm (0.0933 in)
2.4 mm (0.0945 in)
2.42 mm (0.0953 in)
2.45 mm (0.0964 in)
2.47 mm (0.0972 in)
2.50 mm (0.0984 in)
2.52 mm (0.0992 in)
2.55 mm (0.1004 in)
2.57 mm (0.1012 in)
2.6 mm (0.1024 in)
2.62 mm (0.1031 in)
2.65 mm (0.1043 in)
2.67 mm (0.1051 in)
2.7 mm (0.1063 in)
2.72 mm (0.1071 in)
2.75 mm (0.1083 in)
2.77 mm (0.1090 in)
2.8 mm (0.1102 in)
2.82 mm (0.1110 in)
2.85 mm (0.1122 in)
2.87 mm (0.1129 in)
2.9 mm (0.1142 in)
2.92 mm (0.1150 in)
2.95 mm (0.1161 in)
2.97 mm (0.1169 in)
3 mm (0.1181 in)
3.02 mm (0.1189 in)
3.05 mm (0.1201 in)
3.07 mm (0.1209 in)
3.10 mm (0.1220 in)
3.12 mm (0.1228 in)
3.15 mm (0.1240 in)

INDEX OF TOPICS

TROUBLESHOOTING

TROUBL

TROUBLESHOOTING PROCEDURE IF THE EFI WARNING LIGHT ON THE INSTRUMENT PANEL TURNS ON OR IF THERE IS ABNORMAL ENGINE PERFORMANCE

CAUTION

BEFORE CARRYING OUT ANY TROUBLESHOOTING, CAREFULLY READ THE GENERAL TROUBLESHOOTING CONCEPTS FOR ELECTRICAL DEVICES AT THE BEGINNING OF THE CHECK AND CONTROL SECTION IN THE ELECTRICAL SYSTEM CHAPTER.

- 1 - THE "EFI" WARNING LIGHT IS ON AND THE WORD "SERVICE" IS SHOWN or THE "EFI" WARNING LIGHT IS FLASHING AND THE WORDS "URGENT SERVICE" ARE SHOWN or ONE OF THE TWO SITUATIONS TAKES PLACE AND IS SUDDENLY OUT or THERE IS ABNORMAL ENGINE PERFORMANCE
- 2 - CONNECT TO THE DIAGNOSIS INSTRUMENT THROUGH CONTROL UNIT BY SELECTING "SELF-ACQUISITION, APRILIA, RSV4"
- 3 - ARE CURRENT- "ATT"- or STORED- "MEM"- ERRORS SHOWN IN THE "ERRORS DISPLAY" SCREEN PAGE?

YES, go to 4; NO, go to 11.

- 4 - IF THE ERROR IN THE CENTRAL WINDOW IS SELECTED AND "?" IS DISPLAYED, PRESS THE KEY "?" TO OBTAIN FURTHER INFORMATION ABOUT THE ERROR. THEN GO TO THE "ELECTRICAL SYSTEM/CHECKS AND CONTROLS" CHAPTER AND READ THE INFORMATION CONCERNING THE DEFECTIVE COMPONENT
- 5 - ACCORDING TO WHAT IS INDICATED ABOUT THE ERROR/S, PROCEED AS SUGGESTED AND SOLVE THE PROBLEM
- 6 - WAS THE PROBLEM SOLVED BY REPLACING THE MARELLI CONTROL UNIT?

YES, go to 7; NO, go to 8.

- 7 - READ THE ACTIVATION PROCEDURE FOR A NEW CONTROL UNIT ON THE "ELECTRICAL SYSTEM/CHECKS AND CONTROLS/ECU/MARELLI CONTROL UNIT" CHAPTER - END
- 8 - SELECT "ERROR CLEARING" FROM THE "DEVICES ACTIVATION (INJECTOR ICON)" SCREEN PAGE
- 9 - WAS THE PROBLEM SOLVED BY REPLACING THE THROTTLE GRIP SENSOR (DEMAND) OR THE THROTTLE BODY?

NO, END; YES, go to 10

- 10 - READ THE RESET PROCEDURE ON THE "ELECTRICAL SYSTEM/CHECKS AND CONTROLS/THROTTLE GRIP POSITION SENSOR OR THROTTLE BODY" CHAPTER - END
- 11 - CHECK IF THERE ARE CURRENT OR STORED ERRORS DETECTED BY THE INSTRUMENT PANEL REFERRING TO THE "DIAGNOSIS" CHAPTER, "INSTRUMENT

PANEL ERRORS" SECTION. IF THERE ARE ERRORS PRESENT, SOLVE THE FAULT AND SELECT "CLEAR ERRORS"; IF THERE ARE NO ERRORS PRESENT, go to 12

- 12 - IN THE "ENGINE PARAMETER READING" SCREEN PAGE, DOES THE "AIR TEMPERATURE" PARAMETER INDICATE A VALUE EQUIVALENT TO ROOM TEMPERATURE?

YES, go to 13; NO, note A

- 13 - IN THE "ENGINE PARAMETER READING" SCREEN PAGE, DOES THE ENGINE TEMPERATURE PARAMETER WITH COLD ENGINE INDICATE A VALUE SIMILAR TO THAT OF THE AIR TEMPERATURE PARAMETER? AFTER STARTING THE ENGINE, DOES THE PARAMETER INCREASE GRADUALLY INDICATING A CORRECT VALUE?

YES, go to 14; NO, note B

- 14 - IN THE "ENGINE PARAMETER READING" AND THE "LAMBDA CORRECTION" SCREEN PAGES, WITH ENGINE AT IDLE AND ENGINE TEMPERATURE AT $> 65^{\circ}\text{C}$, DOES THE VALUE VARY WITHIN THE 0.85 - 1.15 RANGE?

YES, go to 15; NO, note C

- 15 - IN THE "ENGINE PARAMETER READING" WITH ENGINE AT IDLE AND ENGINE TEMPERATURE $>65^{\circ}\text{C}$, "FRONT THROTTLE CORRECTION" OR "REAR THROTTLE CORRECTION", WITH ENGINE AT IDLE, ARE THE PARAMETERS INCLUDED WITHIN $(-0.8^{\circ} - +0.8^{\circ})$ INTERVAL? AND IN THE SAME SCREEN PAGE, ARE THE "FRONT THROT., POT. 1 (DEGREES)" AND "REAR THROT., POT. 1 (DEGREES)", WITH ENGINE AT IDLE, $> \text{OR} = \text{A } 0.5^{\circ}$? CAUTION: THE DIFFERENCE OF THE THROTTLE CORRECTION VALUES BETWEEN THE REAR AND FRONT CYLINDER MUST NOT BE $>1^{\circ}$

YES, go to 16; NO, note D

- 16 - CHECK: ENGINE SPEED SENSOR, FUEL PRESSURE, INJECTORS (MECHANICAL OPERATION), COILS (SPARK), ENGINE MECHANICS - END

Note A: SEE THE "ELECTRICAL SYSTEM/CHECKS AND CONTROLS/AIR TEMPERATURE SENSOR" CHAPTER.

Note B: SEE THE "ELECTRICAL SYSTEM/CHECKS AND CONTROLS/ENGINE TEMPERATURE SENSOR" CHAPTER.

Note C: SEE THE "ELECTRICAL SYSTEM/CHECKS AND CONTROLS/LAMBDA PROBE" CHAPTER.

Note D: SEE THE "ELECTRICAL SYSTEM/CHECKS AND CONTROLS/THROTTLE BODY" CHAPTER.

See also

[Checks and inspections](#)

The engine does not start

THE ENGINE DOES NOT START, THE INSTRUMENT PANEL TURNS ON.

CAUTION

NAVIGATOR SHOULD BE WORKING PROPERLY AND UPGRADED AT LEAST TO THE 7.0.0 VERSION OR THE PGDS UPDATED AT LEAST TO THE 3.0.0 VERSION

CAUTION

BEFORE ANY TROUBLESHOOTING, MAKE SURE THAT:

- 1) BATTERY VOLTAGE IS ABOVE 12V;**
- 2) THE MAIN 30A FUSE IS NOT DAMAGED AND IS ADEQUATELY FITTED;**
- 3) SECONDARY FUSES ARE NOT DAMAGED AND ARE ADEQUATELY FITTED.**

NOTE

THE RELAY NUMBER SPECIFIED REFERS TO THE WIRING DIAGRAM. THE POSITION OF THE RELAY ON THE VEHICLE IS INDICATED IN THE "ELECTRICAL SYSTEM/COMPONENT LAYOUT/RELAY LAYOUT" CHAPTER.

- 1- WITH THE KEY TURNED TO "ON", THE INSTRUMENT PANEL LIGHTS UP BUT NO FAULT INDICATION IS SHOWN WITH INDICATION "SERVICE" OR "URGENT SERVICE" BUT THE WORD ECU IS READ BELOW and THE PLUG SOCKET DISCONNECTED?

YES, go to CONTROL UNIT SUPPLY CHECK; NO, go to 2

- 2. IS THE FUEL PUMP ACTIVATED?

YES, go to 3; NO, go to FUEL PUMP CHECK

- 3. THE DIAGNOSIS INSTRUMENT COMMUNICATES WITH THE CONTROL UNIT? THAT IS, AFTER SELECTING FUEL INJECTION, AND FOLLOWING THE INSTRUCTION, WITH KEY SET TO "ON", THE PARAMETERS, STATUSES, ETC. ARE READ?

YES, go to 4; NO, go to DIAGNOSIS INSTRUMENT CONNECTION CHECK

- 4. WITH DIAGNOSIS INSTRUMENT ("DEVICES ACTIVATION" SCREEN PAGE, INJECTOR ICON) CARRY OUT ACTIVATION OF A LOWER INJECTOR (IT IS ADVISED TO DISCONNECT THE BLACK FUEL PUMP 4-PIN CONNECTOR, ON THE RIGHT): IS THE INJECTOR ACTIVATED?

YES, go to 5, NO, go to INJECTION RELAY 33 CHECK

- 5. DOES THE MOTOR TURN WHEN THE STARTER SWITCH IS PRESSED?

YES, SEE CHAPTER "ELECTRICAL SYSTEM/CHECK AND CONTROLS/ENGINE SPEED SENSOR and if engine speed sensor works correctly, go to 16; NO, go to 6

- 6. WHAT DOES THE "START-UP ENABLING SWITCH" STATUS IN THE DIAGNOSIS INSTRUMENT, DEVICE STATUS SCREEN PAGE, ICON 0/1 MEAN?

YES, go to STARTER SWITCH CHECK; NO, go to 7

- 7. WHAT DOES THE "FALL SENSOR" STATUS IN THE DIAGNOSIS INSTRUMENT, DEVICE STATUS SCREEN PAGE, ICON 0/1 MEAN?

If NORMAL is shown, go to 8; if TIP OVER is shown, go to 12

- 8. WITH THE SWITCH SET TO "RUN", WHAT DOES THE "RUN-STOP SWITCH" STATUS ON THE DIAGNOSIS INSTRUMENT, DEVICE STATUS SCREEN PAGE, ICON 0/1 MEAN?

If "RUN" is shown, go to 9; if "STOP" is shown, go to 15

- 9. CHECK THROUGH THE DIAGNOSIS INSTRUMENT THE CORRECT OPERATION OF THE SIDE STAND, THE NEUTRAL SENSOR, THE CLUTCH SENSOR: OPERATE ANY DEVICE AND CHECK THE SUITABLE INDICATION ON THE DEVICE STATUS, ICON 0/1 SCREEN PAGE.

If there is a fault, go to 10; if everything works correctly, go to 11

- 10. ACCORDING TO THE FAULT, SEE CHAPTER "ELECTRICAL SYSTEM/CHECK AND CONTROLS/NEUTRAL GEAR SENSOR" or "ELECTRICAL SYSTEM/CHECK AND CONTROLS/GEAR SENSOR" or "ELECTRICAL SYSTEM/CHECK AND CONTROLS/SIDE STAND SENSOR" - END
- 11. REPLACE THE CONTROL UNIT - END
- 12. IS THE SENSOR, IN THE FRAME INTERNAL FRONT NICHE, IN VERTICAL POSITION?

YES, go to 13; NO, go to 14

- 13. REFER TO THE CHAPTER "ELECTRICAL SYSTEM/CHECKS AND CONTROLS/FALL SENSOR"; INDICATION ON DIAGNOSIS INSTRUMENT ALWAYS "TIP OVER" - END
- 14. SET THE SENSOR TO THE CORRECT POSITION - END
- 15. REFER TO THE CHAPTER "ELECTRICAL SYSTEM/CHECKS AND CONTROLS/RUN - STOP SWITCH"; INDICATION ON DIAGNOSIS INSTRUMENT ALWAYS "TIP OVER" - END
- 16. CHECK OPERATION OF FUEL CIRCUIT PRESSURE AND ENGINE MECHANICAL OPERATION - END

See also

[Engine rpm sensor](#)

[Neutral sensor](#)

CHECK CONTROL UNIT POWER SUPPLY

- 1. WITH THE KEY TURNED TO "OFF" CHECK IF THERE IS BATTERY VOLTAGE AT PIN 52 OF THE CONTROL UNIT, CABLE HARNESS SIDE

YES, go to 2; NO, go to 5

- 2. WITH THE KEY TURNED TO "ON" THERE IS BATTERY VOLTAGE AT PIN 40 OF THE CONTROL UNIT, CABLE HARNESS SIDE (IN CASE OF LACK OF POWER SUPPLY ON PIN 42, "URGENT SERVICE" TURNS ON IN THE INSTRUMENT PANEL AND THE CON-

TROL UNIT INDICATES ERRORS RELATED TO THE FRONT AND REAR THROTTLE BODY)

YES, go to 3; NO, go to 6

- 3. CHECK CONTINUITY WITH GROUND CONNECTION AT PIN 5 and 16

If there is continuity, go to 4; if there is not continuity, restore ground connection on the engine front part or restore cable harness

- 4. REPLACE CONTROL UNIT, SEE "ELECTRICAL SYSTEM/CHECK AND CONTROLS/CONTROL UNIT " THE PART RELATED TO NEW CONTROL UNIT ACTIVATION PROCEDURE - END
- 5. CHECK CONTINUITY red/blue CABLE up to secondary fuse D and red/white cable from secondary fuse to 30 A main fuse CHECKING ALSO THE ENGINE - VEHICLE CABLE HARNESS CONNECTOR - END
- 6. CHECK CONTINUITY OF RED/BROWN CABLE FROM PIN 40 TO PROTECTION RELAY 19 CHECKING ENGINE - VEHICLE ELECTRICAL SYSTEM CONNECTOR

If there is continuity, go to PROTECTION RELAY 19 CHECK; if there is not continuity, restore cable harness - END

See also

[Control unit](#)

CHECK FUEL PUMP

- 1. WITH KEY SET TO "ON", DISCONNECT THE CONNECTOR AND CHECK THAT THERE IS BATTERY VOLTAGE ON PIN 1

YES, go to 2; NO, go to 4

- 2. CHECK FUEL PUMP CONNECTOR AND CHECK THAT AT PIN 2 THERE IS GROUND CONTINUITY

YES, go to 3; NO, go to 5

- 3. CHECK ON CONNECTOR ON THE PUMP SIDE, THE ELECTRICAL CHARACTERISTICS: between PIN 1 and PIN 2 there should be a resistance of 0.5 - 1 ohm - END
- 4. CHECK CONTINUITY OF ORANGE/GREEN CABLE FROM PUMP CONNECTOR TO INJECTION RELAY 33 AND RESTORE CABLE HARNESS - END
- 5. RESTORE GROUND CONNECTION - END

DIAGNOSIS INSTRUMENT CONNECTION CHECK

- 1. CHECK CONTINUITY OF WHITE/BLUE CABLE FROM PIN 14 OF THE CONTROL UNIT ON CABLE HARNESS SIDE TO PIN 3 OF THE BLACK CONNECTOR OF THE DIAGNOSIS

YES, go to 2; NO, go to 4

- 2. CHECK THE CONTROL UNIT CONNECTOR AS WELL AS THE DIAGNOSIS BLACK CONNECTOR

YES, go to 3; NO, restore faulty connector - END

- 3. CHECK CORRECT OPERATION OF THE DIAGNOSIS INSTRUMENT CONNECTION CABLE AND THE CORRECT INSTALLATION OF THE PLIERS ON THE BATTERY - END
- 4. CHECK ENGINE CABLE HARNESS - VEHICLE CABLE HARNESS CONNECTOR - END

INJECTION RELAY 33 CHECK

- 1. CHECK CONTINUITY OF THE ORANGE/GREEN CABLE FROM THE LOWER INJECTOR AT PIN 3 OF THE INJECTION RELAY 33, ALSO CHECKING THE ENGINE CABLE HARNESS - VEHICLE CABLE HARNESS CONNECTOR AND THE INJECTION RELAY CONNECTOR

If there is continuity, go to 2; if there is not continuity, restore cable harness - END

- 2. WITH KEY SET TO "ON" IS THERE VOLTAGE ON RED/BROWN CABLE OF THE INJECTION RELAY CONNECTOR, ON THE CABLE HARNESS SIDE?

YES, go to 3; NO, go to 6

- 3. WITH KEY SET TO "ON" IS THERE VOLTAGE ON ORANGE CABLE OF THE INJECTION RELAY CONNECTOR, ON THE CABLE HARNESS SIDE?

YES, go to 4; NO, go to 7

- 4. CHECK CORRECT OPERATION OF THE RELAY, THAT IS, PROVIDING VOLTAGE ON THE CORRESPONDING PIN TO THE RED/BROWN CABLE AND GROUND ON SPECIFIC PIN TO THE BROWN/BLACK CABLE IS THERE CONTINUITY BETWEEN THE OTHER TWO RELAY PINS?

YES, go to 5; NO, replace the relay - END

- 5. REPLACE THE CONTROL UNIT - END
- 6. CHECK CONTINUITY OF RED/BROWN CABLE FROM THE INJECTION RELAY 33 TO THE PROTECTION RELAY 19

If there is continuity, go to PROTECTION RELAY 19 CHECK; if there is not continuity, restore cable harness - END

- 7. CHECK CONTINUITY OF THE CABLE FROM THE INJECTION RELAY 33 TO THE PROTECTION RELAY 19: ORANGE (BETWEEN RELAY 33 AND FUSE F) and RED/BROWN (BETWEEN FUSE RELAY F AND RELAY 19)

If there is continuity, go to PROTECTION RELAY 19 CHECK; if there is not continuity, restore cable harness - END

PROTECTION RELAY 19 CHECK

- 1. WITH KEY SET TO OFF, DISCONNECT THE RELAY CONNECTOR AND CHECK CONTINUITY OF BLUE CABLE WITH GROUND

If there is continuity, go to 2; if there is not continuity, restore cable harness - END

- 2. WITH KEY SET TO OFF, DISCONNECT THE RELAY CONNECTOR AND CHECK IF THERE IS VOLTAGE ON RED/WHITE CABLE

YES, go to 3; NO, restore the cable harness - END

- 3. CHECK CORRECT OPERATION OF THE RELAY, THAT IS, PROVIDING VOLTAGE ON CORRESPONDING PIN TO THE GREEN/BLUE CABLE AND GROUND ON SPECIFIC PIN TO THE BLUE CABLE IS THERE CONTINUITY BETWEEN THE OTHER TWO RELAY PINS?

YES, go to 4; NO, replace the relay - END

- 4. CHECK CONTINUITY OF THE GREEN/BLUE CABLE FROM THE KEY CONNECTOR AT PIN 3 OF THE RELAY CHECKING ALSO THE KEY SWITCH CONNECTOR AND RELAY CONNECTOR

If there is continuity, go to 5; if there is not continuity, restore cable harness - END

- 5. WITH KEY SET TO OFF, CHECK IF THERE IS VOLTAGE ON RED/WHITE CABLE ON THE KEY SWITCH CONNECTOR

YES, go to 6; NO, restore the cable harness - END

- 6. WITH KEY SET TO ON AND CONNECTOR DISCONNECTED, CHECK ON THE SWITCH SIDE IF THERE IS LACK OF CONTINUITY BETWEEN THE TWO PINS CORRESPONDING TO THE RED/WHITE CABLE AND GREEN BLUE AND REPLACE THE KEY SWITCH- END

STARTER BUTTON CHECK

- 1. WITH KEY SET TO "ON" DISCONNECT THE SWITCH CONNECTOR (4-ways black, inside the bow) AND CHECK IF THERE IS VOLTAGE + 5V ON PIN 2 ON THE CABLE HARNESS SIDE

YES, go to 2; NO, go to 5

- 2. WITH CONNECTOR DISCONNECTED (4-ways black, inside the bow) CHECK IF THERE IS GROUND CONNECTION ON PIN 3, ON THE CABLE HARNESS SIDE

YES, go to 3; NO, go to 6

- 3. CHECK WITH CONNECTOR DISCONNECTED (4-ways black, inside the bow) ON THE SWITCH SIDE, PUSHING THE SWITCH, IF THERE IS CONTINUITY BETWEEN PIN 2 AND PIN 3

YES, go to 4; NO, go to 7

- 4. REPLACE THE CONTROL UNIT - END
- 5. CHECK CONTINUITY OF PINK CABLE BETWEEN SWITCH CONNECTOR AND PIN 58 OF THE CONTROL UNIT, CHECKING ALSO THE ENGINE - VEHICLE CABLE HARNESS CONNECTOR

YES, go to 4; NO, restore the cable harness - END

- 6. CHECK CONTINUITY OF PINK/BLACK CABLE BETWEEN SWITCH CONNECTOR AND PIN 4 OF THE CONTROL UNIT, CHECKING ALSO THE ENGINE - VEHICLE CABLE HARNESS CONNECTOR

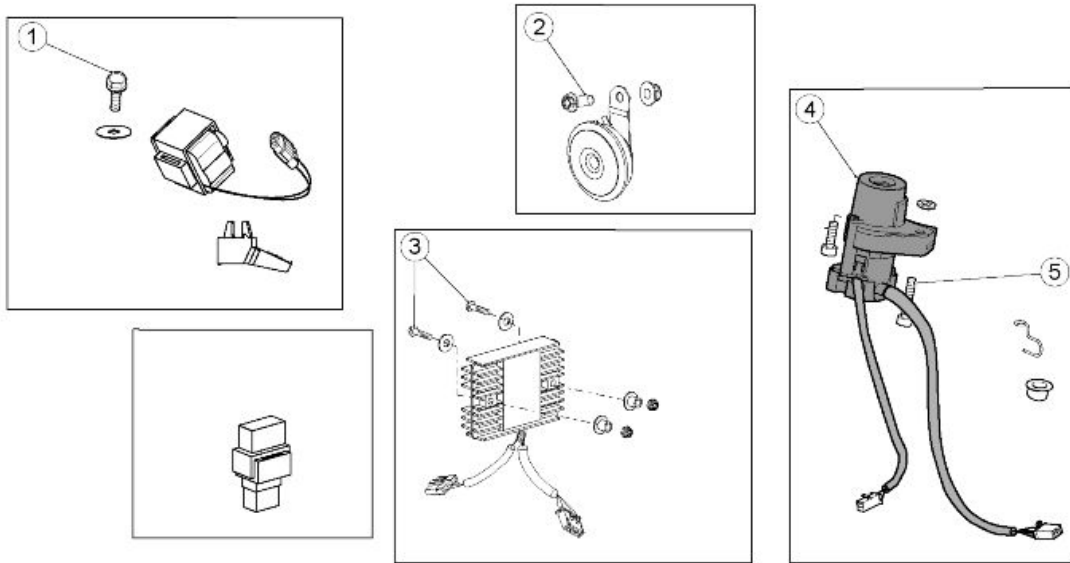
YES, go to 4; NO, restore the cable harness - END

- 7. REPLACE THE STARTER BUTTON COMPONENT - END
-

INDEX OF TOPICS

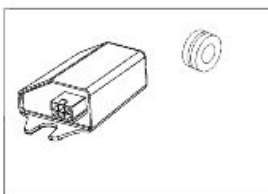
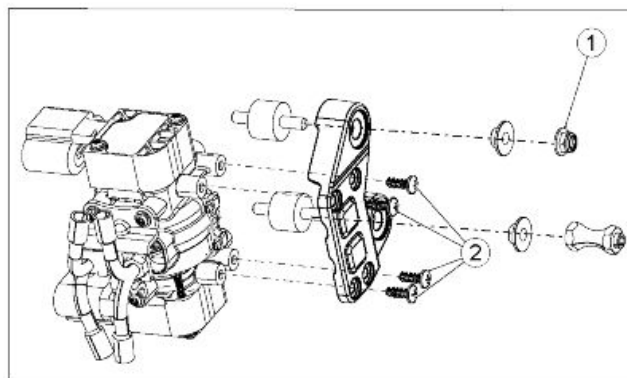
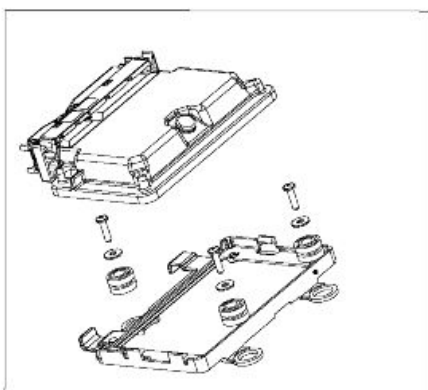
ELECTRICAL SYSTEM

ELE SYS



FRONT ELECTRICAL SYSTEM

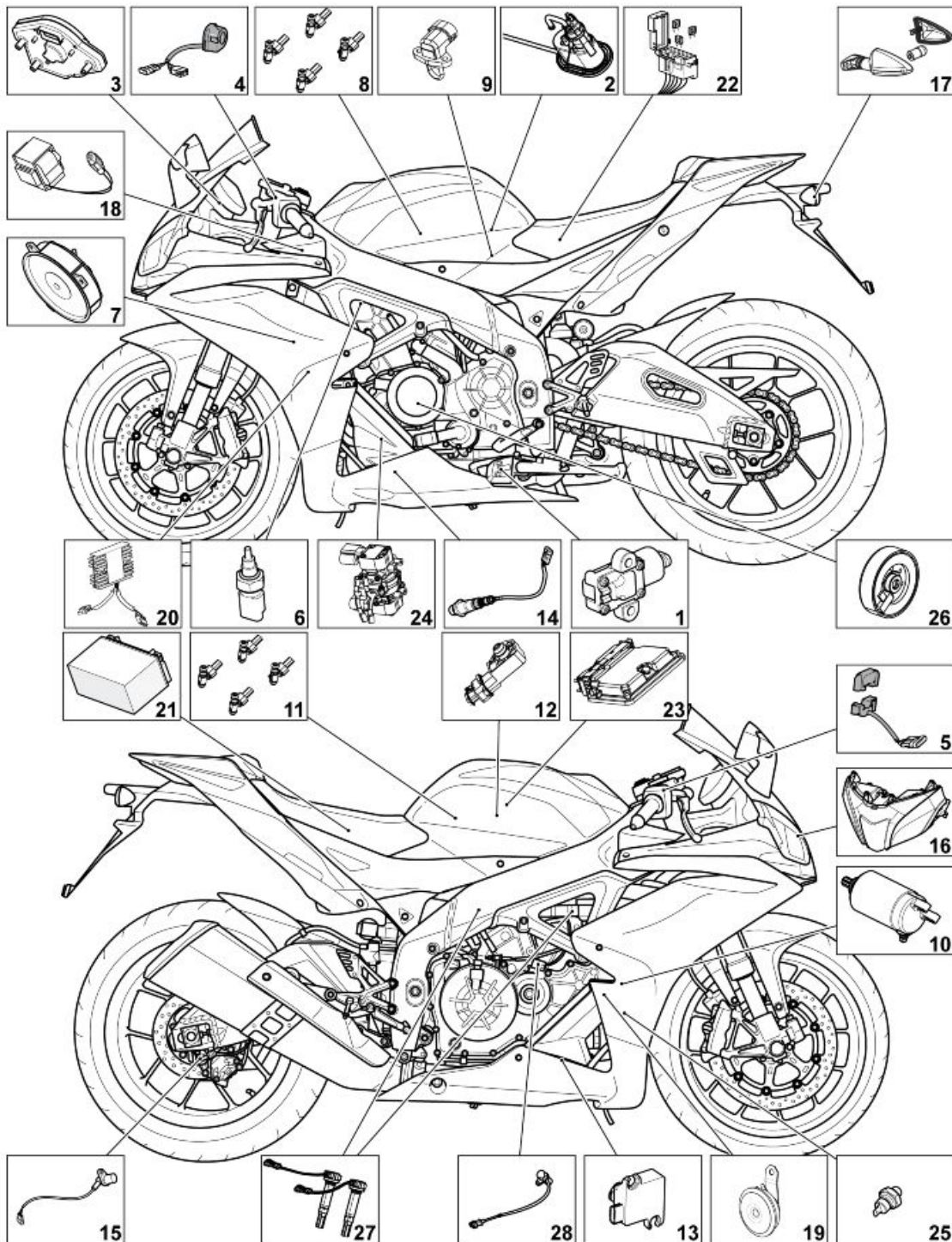
pos.	Description	Type	Quantity	Torque	Notes
1	Fall sensor mounting fixing screw	M6	1	8 Nm (5.9 lbf ft)	-
2	Horn fixing screw	M8	1	15 Nm (11.06 lbf ft)	-
3	Screw fastening the voltage regulator to the inner fairing	M6	2	6 Nm (4.42 lbf ft)	-
4	Shear head screw (to the left of the ignition lock)	M8	1	Manual	Tighten until the head shears off
5	Right hand ignition lock screw	M8	1	20 Nm (14.75 lbf ft)	-



CENTRAL ELECTRICAL SYSTEM

pos.	Description	Type	Quantity	Torque	Notes
1	Upper Silentblock nut, demand sensor mounting bracket	M6	1	5 Nm (3.69 lbf ft)	-
2	Demand sensor fixing screw to mounting plate	SWP 4.9	4	1.2 Nm (0.88 lbf ft)	-

Components arrangement



Key:

1. Side stand sensor
2. Fuel pump
3. Instrument panel
4. Left hand switch
5. Right hand switch
6. Water Temperature Sensor
7. Cooling fans
8. Upper injectors
9. Air temperature sensor
10. Starter motor
11. Lower injectors
12. Air pressure sensor
13. Exhaust valve
14. Lambda probe
15. Speed sensor
16. Headlamp
17. Rear turn indicators
18. Fall sensor
19. Horn
20. Voltage regulator
21. Battery
22. Secondary fuses
23. Control unit
24. Hand grip position sensor
25. Oil pressure sensor
26. Alternator
27. Coils
28. Timing sensor



A RELAY CANNOT BE IDENTIFIED BASED ON THE FOLLOWING INDICATIONS ONLY: THIS HAS TO BE DONE ALSO IDENTIFYING THE COLOUR OF THE RELAY CABLES.

RELAY LAYOUT

Component position in the electrical circuit diagram	Component name	Location on the vehicle
10	Low beam light relay	Windshield front part
9	High beam light relay	Windshield front part
31	Start-up relay	Rear undertail section
19	Protection relay	Under the saddle next to the battery, left side
33	Injection relay	Under the saddle next to the battery, right side
36	Fan control relay	In the niche of the headstock, on the left

Component position in the electrical circuit diagram	Component name	Location on the vehicle
25	Recovery logic relay (urgent service)	In the niche of the headstock, on the right

Electrical system installation

INTRODUCTION

Scope and applicability

The purpose of this document is to define the position of the engine cable harness, its routing and how it is fixed on the engine and the filter box, any potential problems and particular checks to be carried out on the connections and routings in order to reach the objectives of vehicle reliability.

Materials used and corresponding quantities

The electrical system consists of the following cable harnesses and parts:

- 1 Vehicle cable harness
- 1 Front light cable harness
- 1 License plate frame cable harness
- 1 Positive battery cable
- 1 Battery - engine ground cable
- 1 Key switch
- 1 Speed sensor
- 1 Start-up relay
- 5 Relays
- 1 Protection relay
- 1 Horn
- 1 Fall sensor
- 1 Headlamp
- 1 Taillight
- 1 Instrument panel
- 1 Right rear view mirror with turn indicator
- 1 Left rear view mirror with turn indicator
- 1 Rear right turn indicator
- 1 Rear left turn indicator
- 1 Fuel pump unit
- 1 Stand switch
- 1 Exhaust valve actuator
- 1 Oxygen sensor
- 2 Fans
- 1 Right handlebar control
- 1 Left handlebar control

- 1 Regulator
- 1 Hand grip position sensor
- 1 Variable geometry control unit
- 1 Engine cable harness
- 1 Engine revolution sensor
- 1 Control unit 7SM
- 1 Air temperature sensor
- 1 Water temperature sensor
- 2 Coil with short cable (Cylinder 1 and Cylinder 4)
- 2 Coil with long cable (Cylinder 2 and Cylinder 3)
- 1 Gear sensor
- 1 Secondary air solenoid
- 1 Front motorised throttle body
- 1 Rear motorised throttle body
- 2 MAP sensor
- 1 Alternator
- 1 Starter motor
- 4 Upper injectors
- 4 Lower injectors (including the motorised throttle body)

Small parts and mountings

- 6 Large black clamps 178x4
- 6 Small black clamps 160x2.5
- 5 Rubber clamps
- 2 TBEI M6x30N screws
- 2 TE M6x20
- 1 flanged TE 6x16 screw
- 2 M5x8 screws
- 2 TBEI M5x16 screws
- 1 TE M6x30 screw
- 3 Self-tapping 5x14 screws
- 2 flanged TBEI M5x9 screws
- 1 M6 nut
- 2 Flanged self-locking M6 nuts
- 4 Cable grommets
- 1 Cable grommet
- 2 Cable grommets
- 3 Cable guides

- 5 Relay socket rubber rings
- 2 Rubber rings
- 3 Rubber rings
- 2 Rubber rings
- 1 Rubber ring for the protection relay
- 1 Rubber ring for the fall sensor
- 1 AMP Superseal connector mounting
- 1 Relay/fall sensor mounting
- 1 Battery mounting bracket
- 2 T-shaped bushings
- 1 T-shaped bushing
- 2 T-shaped bushings
- 2 6.6x18x1.6 washers
- 1 Spring washer
- 1 5x20x1.5 washer
- 1 Spacer
- 1 Spacer
- 1 Exhaust valve opening cable
- 1 Exhaust valve closing cable
- 1 Instrument panel mounting cover
- 1 Heat-protecting cover
- 1 Control unit mounting
- 3 Large black 178x4 clamps
- 4 Self-tapping 5x20 screws
- 3 Self-tapping screws
- 3 Washers
- 3 Silentblocks
- 2 Self-tapping screws
- 4 AMP Superseal connector mountings
- 1 Mounting for the Framatome connector
- 2 Small black 98x2.5 clamps
- 1 Rubber clamp
- 1 Flanged M6x16 screw
- 1 Secondary air solenoid mounting
- 1 Secondary air pipe
- 1 Secondary air pipe
- 1 Secondary air pipe
- 4 Rubber manifolds

- 4 Clic clamps

Motorcycle division

The wiring timing is subdivided in three essential sections, as indicated in the figure.

1. Front section
2. Central section
3. Rear section



Special checks for the correct connection and laying of cables

It is extremely important that any security-locks for the following connectors are properly connected and correctly tightened to ensure proper engine, and therefore proper vehicle, operation.

- Instrument panel connector
- Demand sensor connectors
- Start-up relay connector
- Speed sensor connector
- Fall sensor connector
- Safety relay connector
- Protection relay connector
- Injection relay connector
- Taillight connector
- Fuel pump connector
- Exhaust valve actuator connector
- Engine-vehicle interface connector
- Flywheel connector
- Regulator connector
- Fan connectors
- Starter motor eyelet
- Stand switch connector
- Right handlebar control connector
- Left handlebar control connector
- Clutch connector

- Key switch connector
- Immobilizer aerial connector
- Oxygen sensor connector
- Output "30" engine revolution sensor connector
- Outputs "25" and "26" 7SM control unit connectors
- Outputs "29", "8", "7" and "28" coil connectors
- Output "15" gear sensor connector
- Output "11" secondary air solenoid connector
- Output "13" front motorised throttle body connector
- Output "14" rear motorised throttle body connector
- Outputs "11" and "27" MAP sensor connectors
- Outputs "20", "21", "22" and "23" upper injector connectors
- Outputs "5", "6", "16" and "17" lower injector connectors

The connectors in the list are circled in the different pictures. The listed connectors are considered more critical than the others because their disconnection could cause the vehicle to stop or malfunction.

Obviously, the correct connection of the other connectors is also important and essential for proper vehicle operation.

It is also important and essential that the instructions regarding the routing and fixing of the cable harness in the various areas are followed meticulously in order to guarantee functionality and reliability.

Front side

TABLE A - RELAY AND FALL SENSOR MOUNTING PRE-FITTING

Check that the fall sensor has been positioned correctly, with the arrow above the indication UPPER facing upward.

1. fall sensor
2. Fall sensor rubber ring
3. Relay
4. Fall sensor connector
5. Mounting

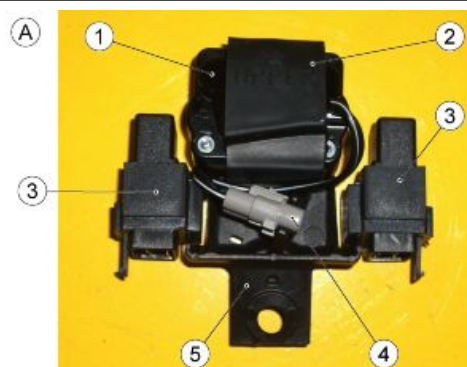


TABLE B - REGULATOR PRE-FITTING

6. Regulator
7. Regulator connector
8. Flywheel connector
9. Self-locking nut (x2)
10. T-shaped bushing (x2)

- 11. TBEI M6x30 screw (x2)
- 12. Washer (x2)

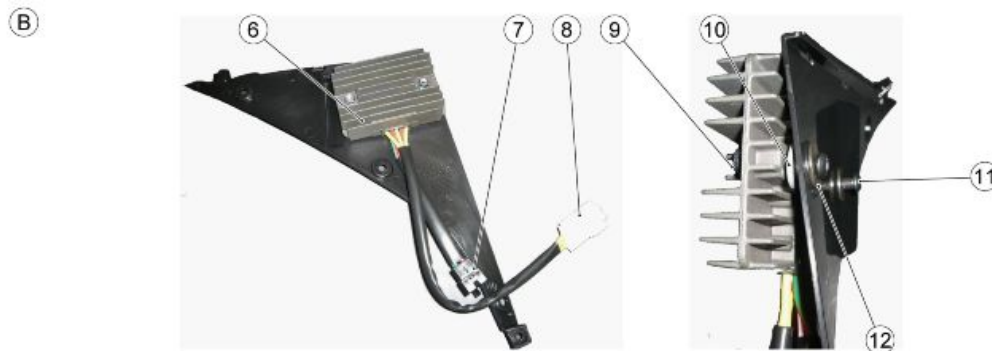


TABLE C1 - HEADLAMP PRE-FITTING

The headlamp cable harness (23) and the two relays with a relay socket rubber ring (17) must be fit on the headlamp (13) as shown in the photos below.

- 13. Headlamp
- 14. Left position light connector
- 15. Cable harness routing in the cable grommet
- 16. Cable grommet
- 17. Relay with relay socket rubber ring
- 18. Cable harness routing in the cable grommet
- 19. Right position light connector
- 20. Right low beam light connector
- 21. Vehicle cable harness interface connectors
- 22. High beam light connector
- 23. Headlamp cable harness
- 24. Left low beam light connector

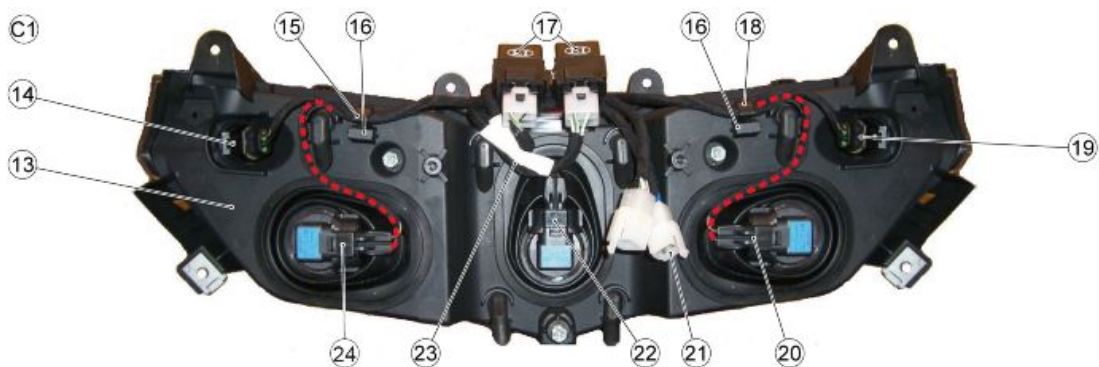
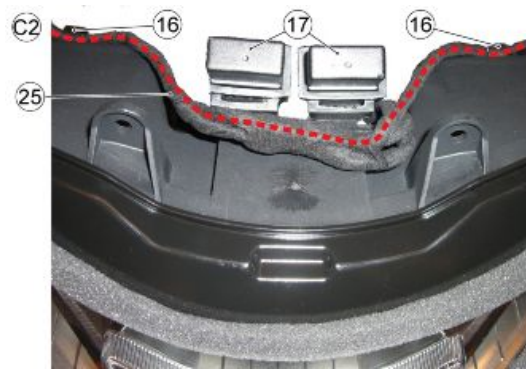


TABLE C2 - HEADLAMP PRE-FITTING

- 16. Cable grommet
- 17. Relay with relay socket rubber ring
- 25. Cable harness routing behind the relay

**TABLE D - HANDLEBAR CONTROLS**

- 26. Left handlebar control
- 27. Clutch connector
- 28. Right handlebar control

**TABLE E - INSTRUMENT HOLDER SUPPORT AND FRONT PART**

Use a clamp (31) to fasten the vehicle cable harness, in correspondence of the grey taping, on the specific seat located on the instrument holder support.

Connect the Immobilizer antenna connector (30) to the corresponding cable harness connector.

- 29. Antenna connector
- 30. Ignition switch
- 31. Clamp

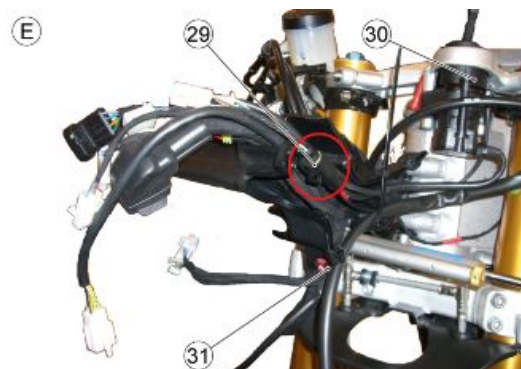


TABLE F - INSTRUMENT HOLDER ARCH BRACE AND FRONT PART

Pass all the cable harnesses arriving from the right semi-handlebar (right handlebar control + front stop switch) and from the left semi-handlebar (left handlebar control + key switch) inside of the right arch brace, as shown in the figure; also pass the cable with the clutch connector on the vehicle cable harness together with the left switch cable harness.

Use a clamp (32), as shown in figure, to hold the various cable harnesses inside the arch brace.

32. Clamp


TABLE G - INSTRUMENT HOLDER ARCH BRACE AND FRONT PART

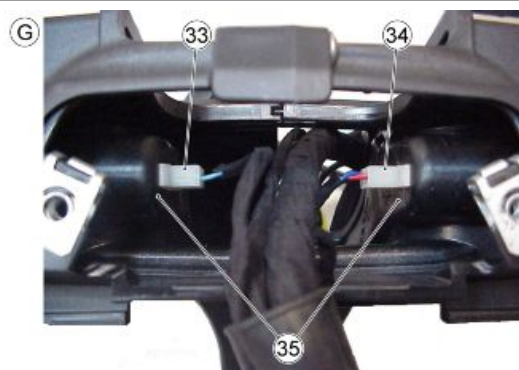
The left arch brace can now be fit.

After fitting the left arch brace, the clamp used for holding the cable harnesses inside the arch brace itself must be cut and removed.

33. Left turn indicator connector (cable colours: light blue and blue)

34. Right turn indicator connector (cable colours: red and blue)

35. Insert the connectors into their seats on the arch brace


TABLE H - INSTRUMENT HOLDER ARCH BRACE AND FRONT PART

36. Key switch connector (cable harness with red taping)

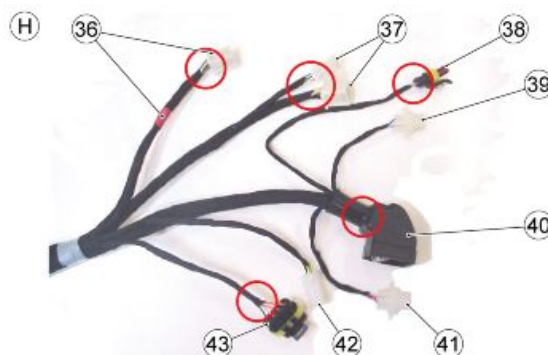
37. Left handlebar control connectors

38. Antenna connector

39. Left turn indicator connector (cable colours: light blue and blue)

40. Instrument panel connector

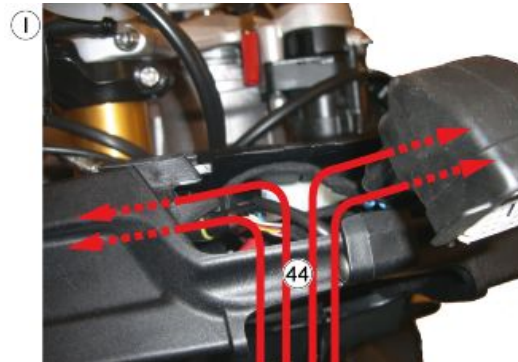
41. Right turn indicator connector (cable colours: red and blue)



- 42. Front stop switch connector
- 43. Right handlebar control connector

TABLE I - INSTRUMENT HOLDER SUPPORT AND FRONT PART

Make the connections for all connectors. The key switch connector has a longer cable harness in comparison to the 6 pin connectors for the left light switch. The cable harness side ignition switch connector is distinguished with red taping on its branch.



- 44. Insert the connectors inside the two support compartments (left and right)

TABLE J - INSTRUMENT HOLDER ARCH BRACE AND FRONT PART

- 45. Rubber ring (x3)
- 46. Screw (x3)
- 47. Washer (x3)
- 48. Instrument panel

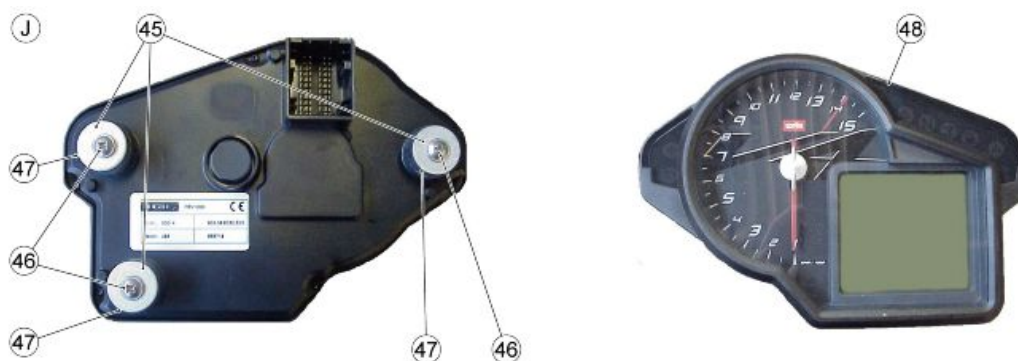


TABLE K - INSTRUMENT HOLDER ARCH BRACE AND FRONT PART

- 49. Insert the instrument panel rubber rings in their seats on the arch brace.
- 50. Instrument panel connector
- 51. Instrument panel mounting cover
- 52. Screw

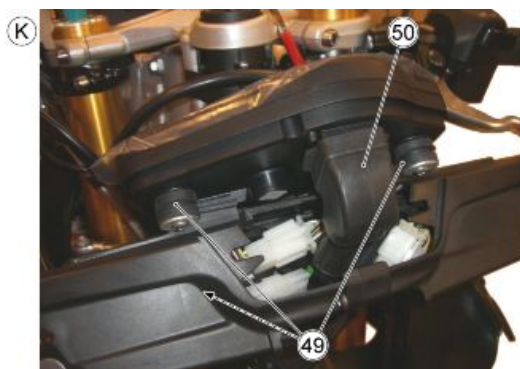


TABLE L - INSTRUMENT HOLDER SUPPORT AND FRONT PART

Right side

Check that the cable grommets are not tensioned on the right and left cable grommet during steering rotation.

53. Cable harness routing to right handlebar control

54. Front stop switch cable harness routing

55. Rubber clamp

56. Cable grommet

57. Red reference tape on the right handlebar control cable harness in correspondence of the cable grommet.

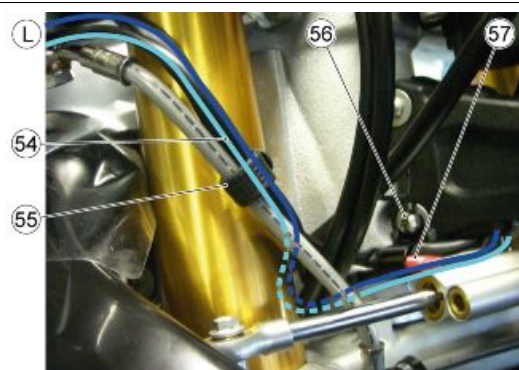


TABLE M - INSTRUMENT HOLDER ARCH BRACE AND FRONT PART

Left side

Check that the cable grommets are not tensioned on the right and left cable grommet during steering rotation.

58. Antenna cable harness routing

59. Key switch cable harness routing

60. Rubber clamp

61. Cable harness routing to left handlebar control

62. Clutch cable harness routing

63. Cable grommet

64. Red tape on the clutch and left handlebar control cable harness in correspondence of the cable grommet.

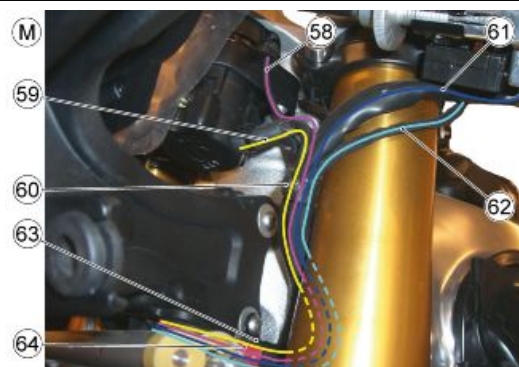


TABLE N - COMPLETION OF THE FRONT

65. Headlamp connectors

66. Headlamp connector positioning (as shown in the figure)

**TABLE O - COMPLETION OF THE FRONT**

Check that the turn indicator connectors are inserted correctly and do not return inside the instrument holder arch brace.

67. Front right turn indicator connectors

68. Front left turn indicator connector



Central part**TABLE A - RADIATOR AREA****Right side**

1. Cable grommet
2. Vehicle cable harness

**TABLE B - RADIATOR AREA****Right side**

3. Starter motor
4. Clamp
5. Exhaust valve actuator cable harness routing
6. Oil pressure sensor and cable harness routing

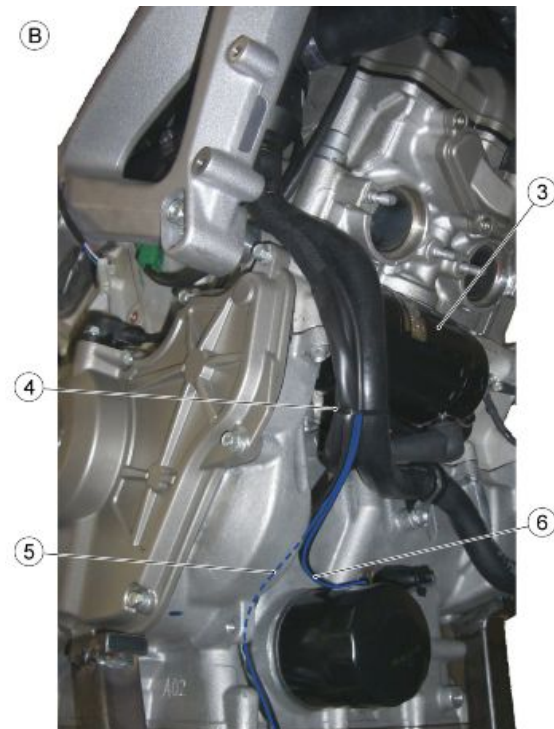


TABLE C - RADIATOR AREA

The ground cable harness routing is behind the water pipe and behind the starter motor, as indicated by the arrow.

- 3. Starter motor
- 4. Clamp
- 5. Exhaust valve actuator cable harness routing
- 6. Oil pressure sensor and cable harness routing

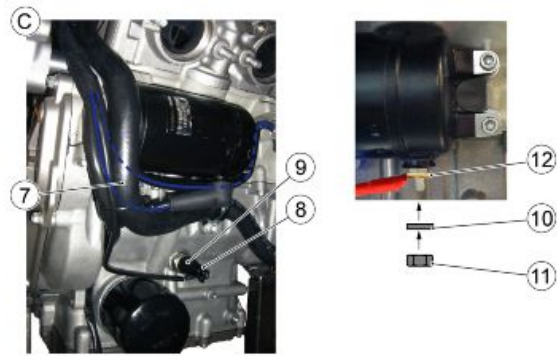


TABLE D - RADIATOR AREA

- 13. Vehicle connector
- 14. Engine connector
- 15. **Check that the connectors are inserted correctly and that the purple slide is at the end of stroke (as shown in the figure).**

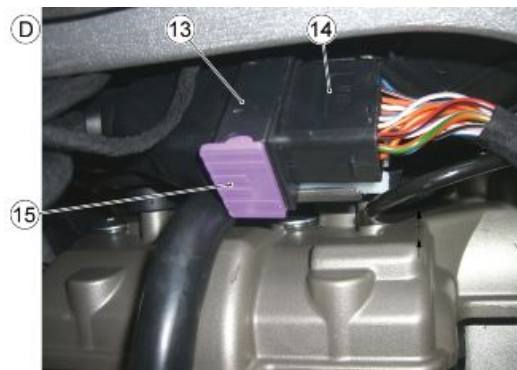


TABLE E - RADIATOR AREA

Left side

Check that the connectors are inserted correctly and that the security locks are in the locked position.

- 16. Master Demand connector (blue).
- 17. Slave Demand connector (white)

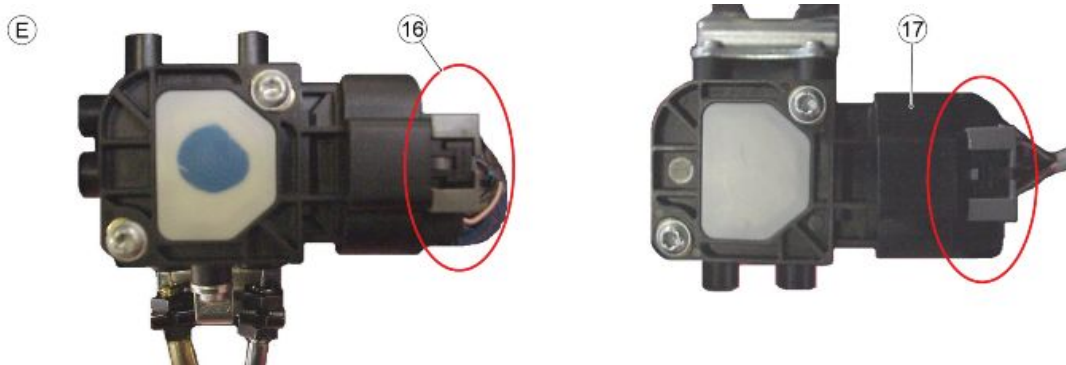
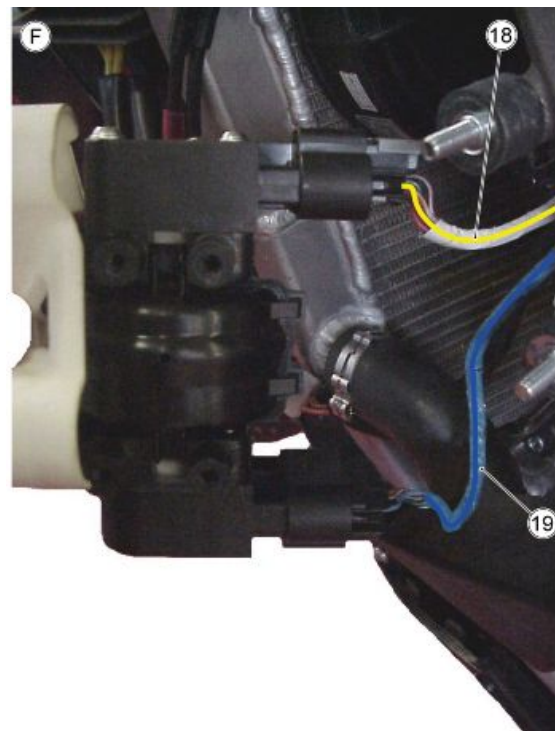


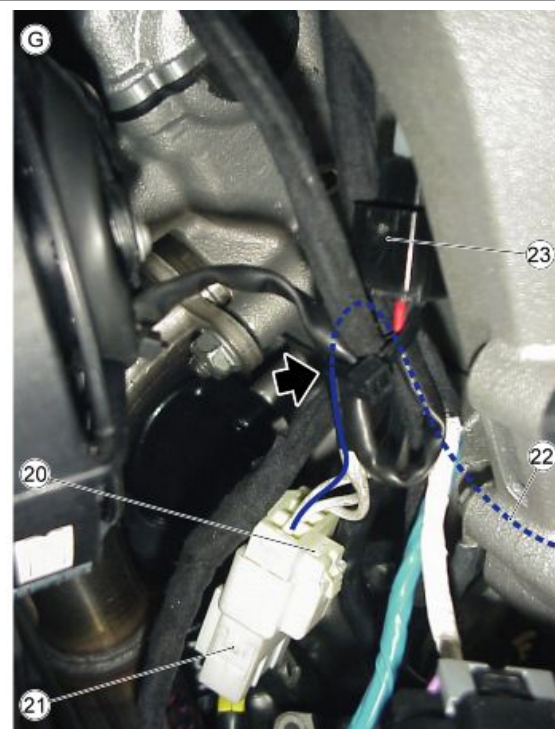
TABLE F - DEMAND SENSOR FITTING

- 18. Slave Demand cable harness routing (creating a "U-bend" in the cable harness)
- 19. Master Demand cable harness routing (creating a "U-bend" in the cable harness)

**TABLE G - DEMAND SENSOR FITTING**

Clamp where indicated.

- 20. Flywheel connector
- 21. Flywheel connector to the regulator
- 22. Flywheel cable harness routing

**TABLE H - DEMAND SENSOR FITTING**

- 24. Clamp (flywheel cable harness and regulator cable harness routing)
- 25. Flywheel cable harness routing

The flywheel connectors must be positioned between the two demand connectors, so that they remain away from the exhaust pipes.

- 26. Flywheel connector to the regulator

- 27. Flywheel connector
- 28. Regulator connector
- 29. Regulator connector on the vehicle cable harness

Ⓜ

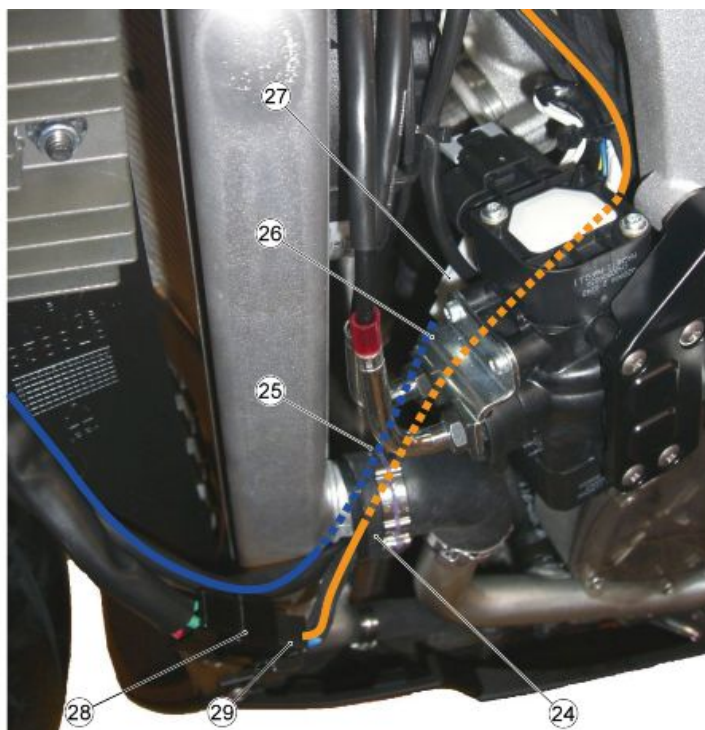


TABLE I

Right side

- 30. Instrument panel branch vehicle cable harness
- 31. Fan connector
- 32. Clamp



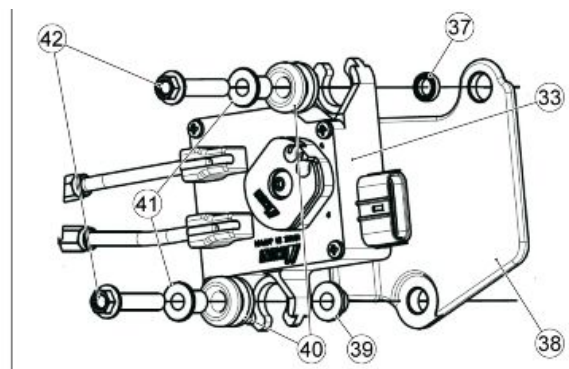
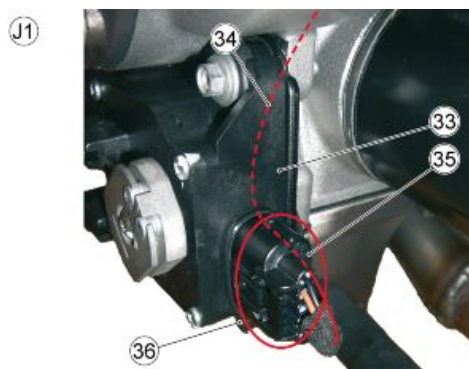
TABLE J1 - EXHAUST VALVE ACTUATOR

Positioning and calibration

- 33 Exhaust valve actuator
- 34. Exhaust valve actuator cable harness routing
- 35 Exhaust valve actuator connector
- 36. Clamp
- 37. Spacer
- 38 Heat-protecting cover
- 39. Spacer
- 40. Rubber ring

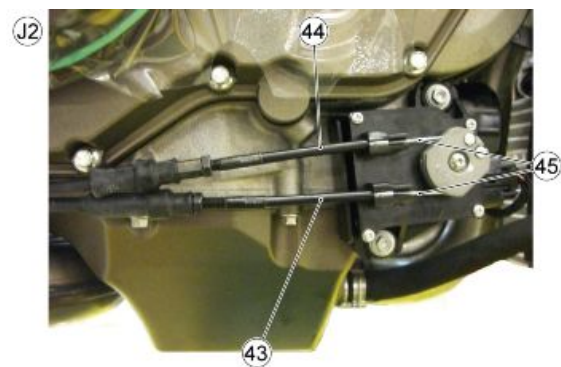
41. T-shaped bushing

42. M6x30 screw



**TABLE J2 - EXHAUST VALVE ACTUATOR
Positioning and calibration Actuator - valve
Bowden cable (45) fitting procedure**

- Insert the cables with the set screws closed in the following sequence:
 1. Valve side closing cable (44) (univocal fitting)
 2. Actuator side closing cable (44)
 3. Valve side opening cable (43) (univocal fitting)
 4. Actuator side opening cable (43)
 - Turn the closing cable set screw until there is a distance of 1.9-2 mm (0.0748-0.0787 in) between the mechanical endstop and the pulley.
 - Finally tighten the lock nut on the set screw.



**TABLE J3 - EXHAUST VALVE ACTUATOR
Positioning and calibration Actuator - valve
Bowden cable (45) fitting procedure**

- Turn the opening cable (43) set screw until the cable tension is identical to the closing cable (44).
- Finally tighten the lock nut on the set screw.

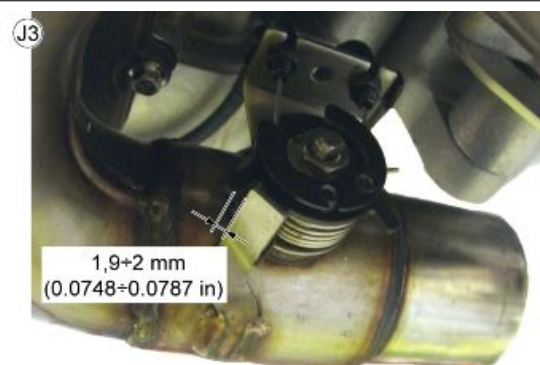
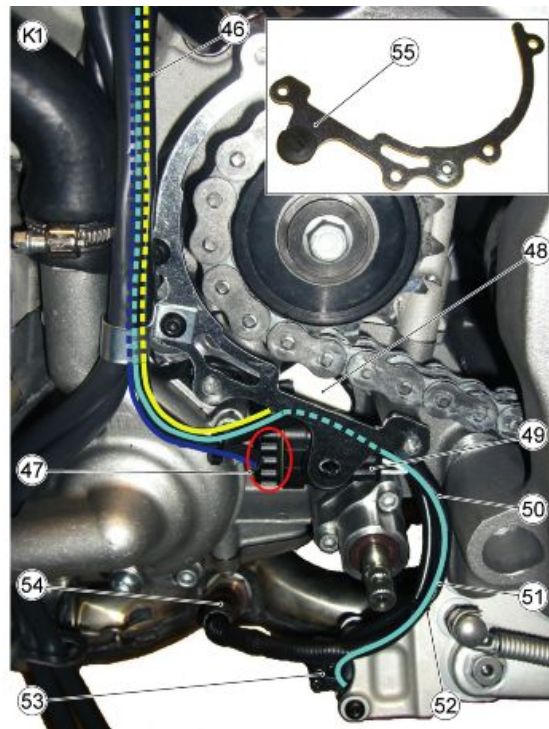


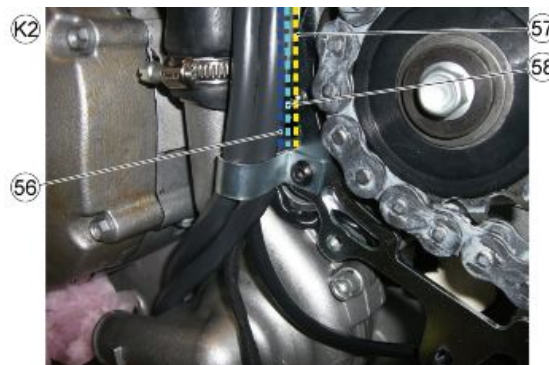
TABLE K1 - PINION CASING AREA

- 46. Gear sensor cable harness routing
- 47. Oxygen sensor connector on the vehicle cable harness
- 48. Gear sensor
- 49. Oxygen sensor connector
- 50. Stand switch cable harness routing
- 51. Oxygen sensor cable harness routing
- 52. Clamp
- 53. Stand switch
- 54. Lambda probe
- 55. Mounting

**TABLE K2**

Pass the cable harnesses behind the cable grommet that closes the two fuel breather pipes.

- 56. Oxygen sensor cable harness routing
- 57. Gear sensor cable harness routing
- 58. Stand switch cable harness routing

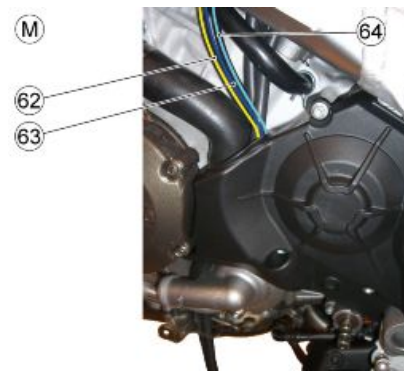
**TABLE L**

- 59. Cable guide
- 60. Oxygen sensor cable harness routing
- 61. Stand switch cable harness routing



TABLE M

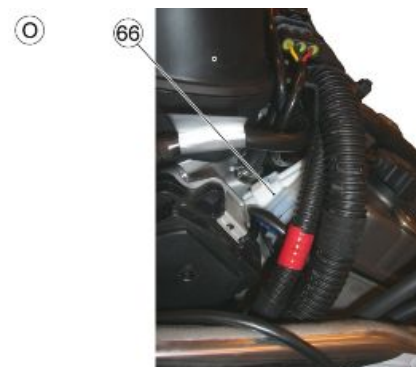
- 62. Gear sensor cable harness routing
- 63. Oxygen sensor cable harness routing
- 64. Stand switch cable harness routing

**TABLE N**

- 65. Stand switch connector

**TABLE O**

- 66. Position the gear sensor and stand switch connectors under the corrugated pipes (as indicated in the figure)

**TABLE P1 - NOTES FOR FITTING THE GROUND CABLES**

- 67. Flanged M6x15 screw
- 68. Engine GND lug terminal from the engine cable harness
- 69. Engine GND lug terminal from the vehicle cable harness
- 70. Engine - battery ground cable engine Gnd lug terminal
- 71. Cable grommet
- 72. Flanged M6x16 screw
- 73. Chassis GND lug terminal from the engine cable harness

To avoid inverting the ground connections, unscrew the screw (67) from the engine; to connect the other ground connections, the chassis ground cable (73) can be connected with the screw (72), as shown in the figure.

CAUTION

BE CAREFUL NOT TO INVERT THE TWO GROUND LUG TERMINALS (68) AND (73).

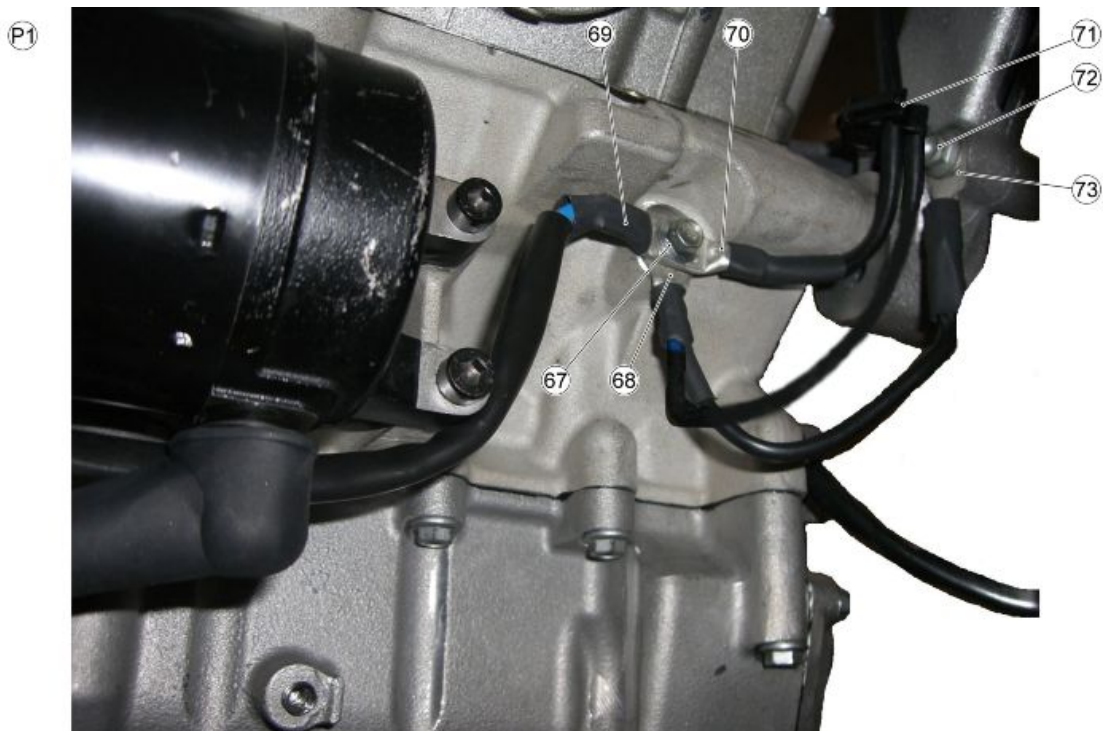


TABLE P2 - ENGINE - BATTERY GROUND CABLE ROUTING

Clamp the engine- battery ground cable harness to the Demand sensor cable harness as far up as possible.

74. Clamp

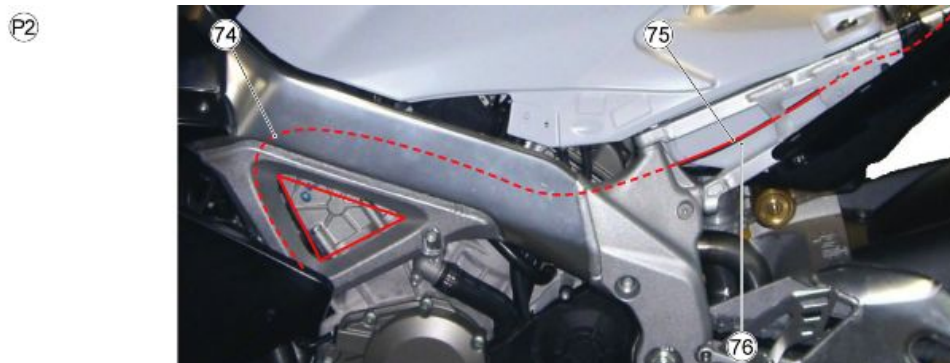
75. Battery - engine ground lead

76. Engine - battery ground cable harness routing

The engine - battery ground cable harness must not be visible within the area indicated with a red triangle.

CAUTION

BE CAREFUL NOT TO INVERT THE TWO GROUND LUG TERMINALS (68) AND (73).

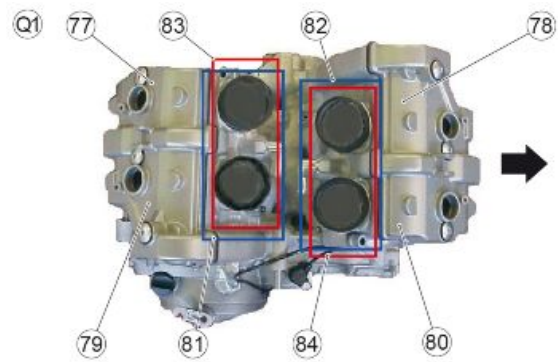


CENTRAL Q1 - NOTES FOR ENGINE CABLE HARNESS FITTING

Definition of component numbering:

Upper view

- 77. Cylinder 1
- 78. Cylinder 2
- 79. Cylinder 3
- 80. Cylinder 4
- 81. Cylinder bank 1
- 82. Cylinder bank 2
- 83. Throttle body 1 (FARF 1)
- 84. Throttle body 2 (FARF 2)



CENTRAL Q2

Right side view

- 86. Engine speed sensor
- 87. Starter motor

Left side view

- 87. Starter motor
- 88. Alternator
- 89. Gear sensor

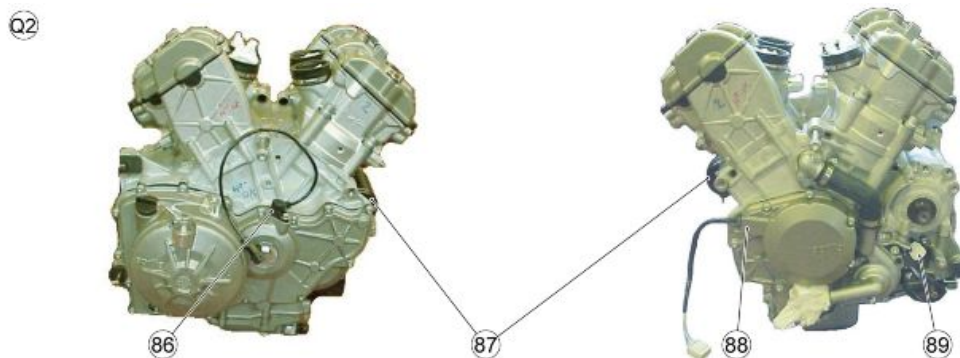


TABLE R - ENGINE CABLE HARNESS LAYOUT

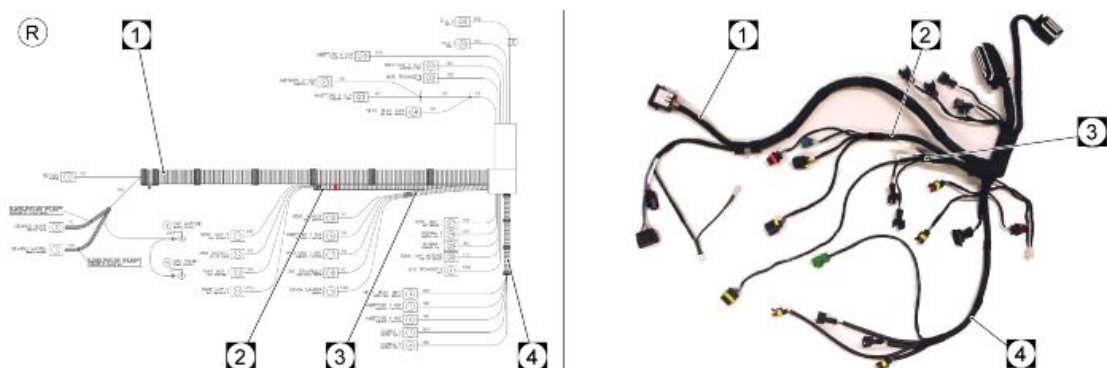


TABLE S1 - FILTER BOX COVER AND LOWER FILTER BOX PREPARATION

Fit four mountings for the "coil" connectors and the mounting for the "vehicle" connector as shown in figures S1, S2 and S3.

Lower filter box

- 90. Self-tapping 5x20 screw
- 91. Connector mounting
- 92. Connector mounting

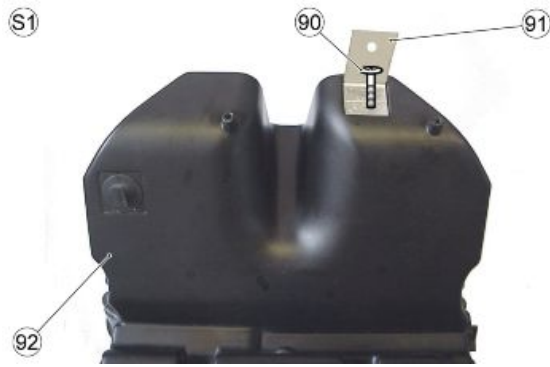


TABLE S2

Lower filter box

- 93. Connector mounting



TABLE S3

Filter box cover

- 94. Connector mounting

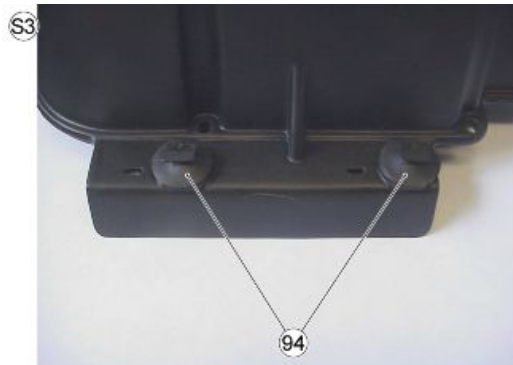


TABLE T - CONTROL UNIT MOUNTING PREPARATION

Fit the three silent blocks (96) onto the seats on the mounting; then, fit the 7SM control unit (95) using the specific links.

- 95. 7SM control unit
- 96. Silent block
- 97. Control unit mounting



TABLE U - MOTORISED THROTTLE BODY CONNECTION PREPARATION AND SECONDARY AIR SOLENOID FITTING

Before fitting the motorised throttle bodies (98 and 99), the respective engine cable harness connectors must be connected: on branch "2" of the cable harness (corrugated pipe marked with RED tape), there are outputs 13 and 14, which are respectively motorised throttle body 1 (98 - rear) (shorter branch) and motorised throttle body 2 (99 - front) (longer branch).

98. Rear motorised throttle body

99. Front motorised throttle body



TABLE V

Check that the connectors are inserted correctly and that the security locks are in the locked position.



CENTRAL W - FITTING THE PIPES ON THE SECONDARY AIR SOLENOID

100. Pipe

101. Pipe

102. Pipe

103. Secondary air solenoid mounting

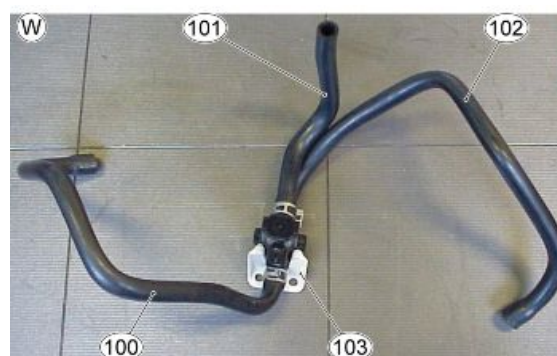


TABLE X - FITTING AND CONNECTING THE SECONDARY AIR SOLENOID AND FITTING THE RUBBER MANIFOLD WITH THE CLIP-ON CLAMP

104. Rubber manifold

105. Clip-on clamp



TABLE Y - MOTORISED THROTTLE BODY FITTING

Y

First fasten the "Motorised Throttle Body 2 (front)" to the rubber manifolds with the specific clip-on clamps.

Then fasten the "motorised throttle body 1 (rear)" to the rubber manifolds with the clip-on clamps using the specific tool.

106. Cable harness routing (branch "4") under the fuel pipe



Specific tooling

020877Y Pliers for clamps

TABLE Z

Z

First fasten the "Motorised Throttle Body 2 (front)" to the rubber manifolds with the specific clip-on clamps.

Then fasten the "motorised throttle body 1 (rear)" to the rubber manifolds with the clip-on clamps using the specific tool.

106. Cable harness routing (branch "4") under the fuel pipe.

Pay attention when positioning the Map Sensor 2 connector.



Specific tooling

020877Y Pliers for clamps

TABLE ZA - H2O TEMPERATURE SENSOR AND LOWER INJECTORS CONNECTION

ZA

Cable harness routing on the right side of the engine: branch "4" of the cable harness must pass behind the Front Motorised Throttle Body; the output with the branchings must be positioned in correspondence of the upper part of the head cover.

110. Engine speed sensor connector

111. Output with branchings

112. Engine speed sensor cable routing

113. Cable harness routing (branch "4") under the water pipe fitting.

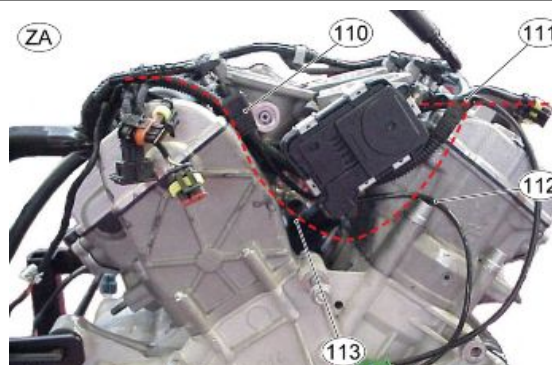


TABLE ZB - H2O TEMPERATURE SENSOR

114. Cable harness routing (branch "4") under the 3-way fitting

115. Engine speed sensor cable routing between the front motorised throttle body and the 3-way fitting

116. Rubber clamp

**TABLE ZC**

At this point, the injectors 2 (output "5") and 4 (output "6") can be connected: the connector (117) for injector 4 is GREY (or there is a spot with grey tape on the cable harness) whereas the connector (119) for injector 2 is BROWN.

Move the connector for coil 2 (output "7"), marked with red tape, to the far left, routing with the respective wiring together with the injector cable harnesses.

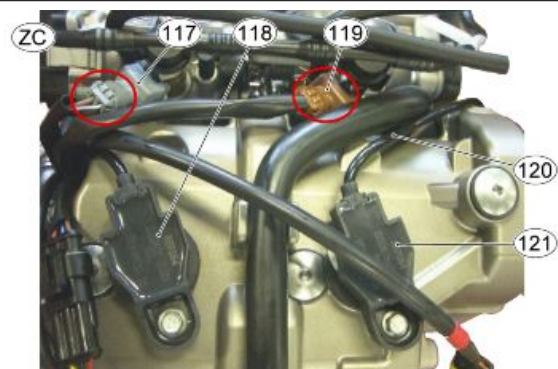
117. Lower injector 4 cable harness connector (output "6") - grey connector

118. Coil 4 - short cable harness

119. Lower injector 2 cable harness connector (output "5") - brown connector

120. Coil 2 cable harness routing (output "7")

121. Coil 2 - long cable harness

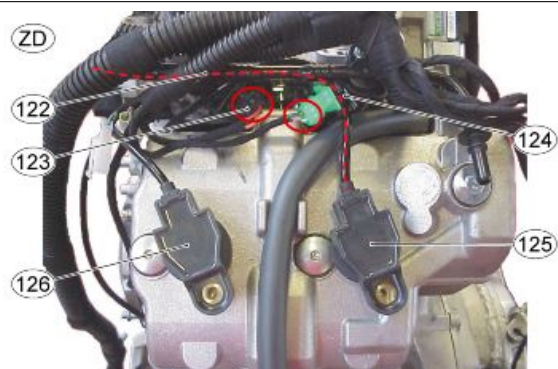
**TABLE ZD**

Connect the injectors 1 (output "16") and 3 (output "17"), which are on branch "3": the connector (123) for injector 1 is BLACK whereas the connector (124) for injector 3 is GREEN (or there is a spot with blue tape on the cable harness).

Move the cable for coil 3 to the far left, routing it as shown in the following figure (122).

122. Coil 3 cable routing

123. Lower injector 1 cable harness connector (output "16") - black connector



- 124. Lower injector 3 cable harness connector (output "17") - green connector
- 125. Coil 3 - long cable harness
- 126. Coil 1 - short cable harness

TABLE ZE - COIL AND MAP SENSOR CONNECTION

Once the filter box is assembled, the coil and map sensor connections must be made. The connectors for the 4 coils (AMP Superseal male plug housing) must be placed on the mountings that were previously fit on the filter box: to do this, insert the slide positioned under the connector in the plastic tooth of the mounting.

Passage of coil 3 and coil 1 cables between the Fuel Rail and the filter box

- 127. Coil 1 connector
- 128. Coil 1 cable harness connector (output "29")
- 129. Coil 3 connector
- 130. Coil 3 cable harness connector (output "28")

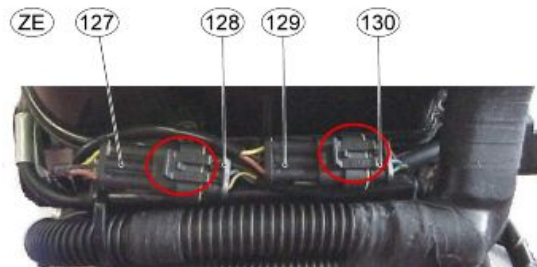


TABLE ZF

- 131. Coil 4 cable harness connector (output "8")
- 132. Coil 4 connector



TABLE ZG

- 133. Coil 2 connector
- 134. Coil 2 cable harness connector (output "7")
- 135. Map sensor 2
- 136. Self-tapping 5x20 screw
- 137. Map sensor 2 cable harness connector (output "11")
- 138. Insert the tape clamp on the cable harness in the free hole on the filter box



TABLE ZH

Once the Engine Speed Sensor (output "30") connector (142) has been connected to its counterpart, it must be clamped, using the indicated clamp (143), to the Blow-by pipe in the position shown in the figure.

139. Map sensor 1

140. Self-tapping 5x20 screw

141. Map sensor 1 cable harness connector (output "27")

142. Engine speed sensor cable harness connector (output "30")

143. Clamp



CENTRAL ZI - GEAR SENSOR CONNECTION AND OXYGEN SENSOR CABLE HARNESS ROUTING

Once the "Gear Sensor" (output "15") connector (144) has been connected to its counterpart, it must be moved behind the corrugated pipes to the position shown in the figure (145).

144. Gear sensor cable harness connector

145. Cable harness routing and connector position behind the corrugated pipes

**CENTRAL ZJ**

The "Oxygen sensor" (output "19") cable harness (147) must go down along the left side of the engine together with the Gear Sensor cable harness.

146. Oxygen sensor cable harness routing

147. Oxygen sensor cable harness connector (output "19")

**TABLE ZK - AIR TEMPERATURE SENSOR AND UPPER INJECTORS CONNECTION**

148. Upper injectors

149. Upper injector 2 cable harness connector (output "20") - brown connector

150. Upper injectors

151. Upper injector 4 cable harness connector (output "21") - grey connector

152. Upper injector 3 cable harness connector (output "22") - green connector

153. Air temperature sensor cable harness connector (output "24")

154. Air temperature sensor

155. Upper injector 1 cable harness connector (output "23") - black connector

156. Self-tapping screw

Connect the upper injectors as shown in the figure and according to the following sequence:

Injector 1 (output "23"): **BLACK** connector

Injector 2 (output "20"): **BROWN** connector

Injector 3 (output "22"): **GREEN** connector

Injector 4 (output "21"): **GREY** connector

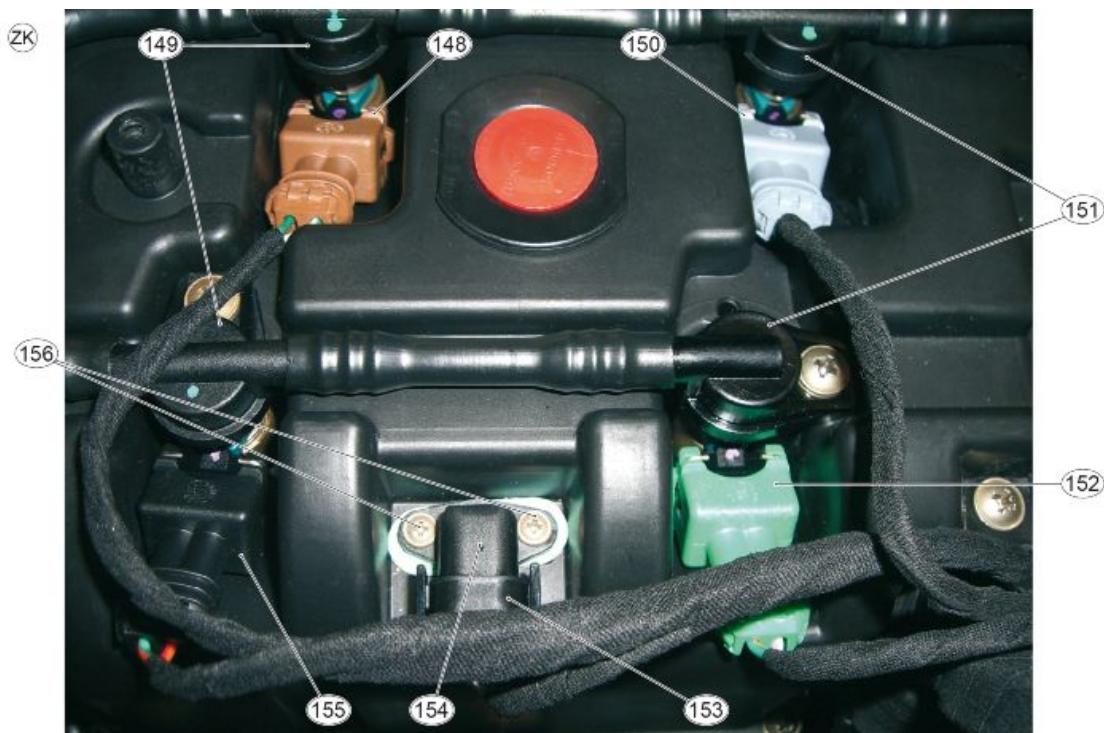


TABLE ZL - 7SM CONTROL UNIT FITTING AND CONNECTION

After connecting the upper injector connections and the air temperature sensor connector, the 7SM control unit can be fastened, which was previously fastened to its relative mounting.

157 Washer

158. Self-tapping screw



TABLE ZM

159. Clamp

160. Self-tapping 5x20 screw

**TABLE ZN**

The connectors (161) "ECU 1" (output "26") and (162) "ECU 2" (output "25") must be connected to their respective connectors on the 7SM control unit, being very careful when inserting them. The slides must move freely until the end of the stroke, which helps with connector insertion: you must hear the release of the retaining tang at the end of the stroke.

161. "ECU 1" cable harness connector (output "26")

162. "ECU 2" cable harness connector (output "25")

163. Cable harness routing (output "25") under the mounting

164. Cable harness routing (output "25") above the mounting



TABLE ZO

It is advisable to create a jig in order to check the correct insertion of both connectors.

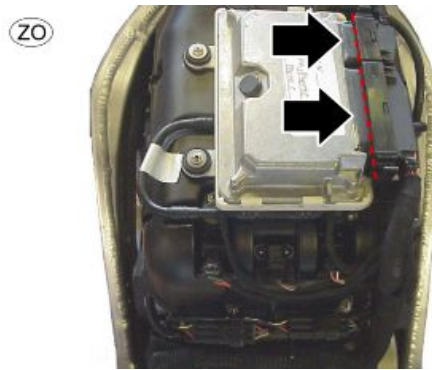


TABLE ZP - VEHICLE CONNECTOR FASTENING

The "VEHICLE" (output "1") connector (165) must be fastened to the mounting with the white slide pre-fit on the connector itself, in the position indicated in the figure.

- 165. Vehicle cable harness connector (output "1")
- 166. Connector mounting



TABLE ZQ - CONNECTORS FOR INTAKE DUCT CONTROL UNIT AND INTAKE DUCT MOTOR

The "Intake duct mot." (output "32") connector (167) must be fastened with a small black clamp (170) as shown in the figure.

- 167. Intake duct motor connector (output "32")
- 168. Cable harness routing
- 169. Intake duct motor cable harness connection (output "32")
- 170. Clamp

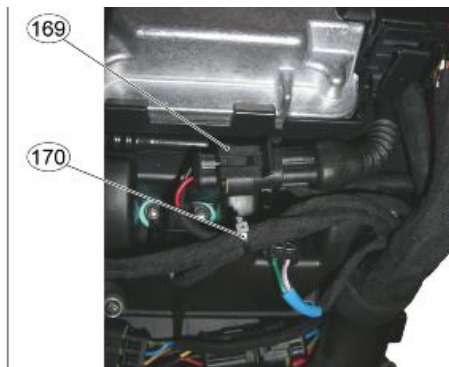


TABLE ZR (If available)

Clamp (170) the connector (171) together with the main cable harness and rear brake switch connected as indicated in the figure.

Connect the connector (171) to the control unit.

- 170. Clamp
- 171. Intake duct "ECU" cable harness connector (output "31")

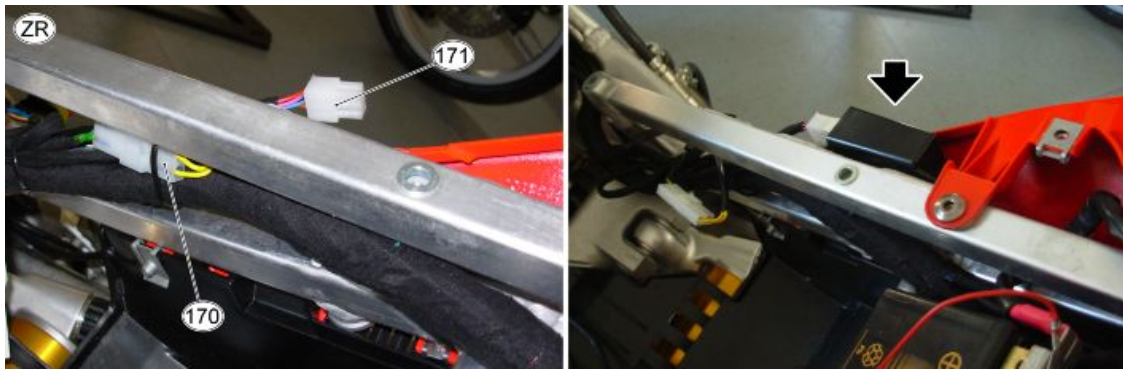


TABLE ZS - NOTES FOR FITTING THE GROUND CABLE

There are two ground lug terminals on the cable harness: the "ENGINE GND" (output "9") and the "CHASSIS GND" (output "10").

The "ENGINE GND" lug terminal (172) (output "9") must be connected to the M6 hole on the upper engine crankcase with a flanged M6x16 screw (173). The other "CHASSIS GND" lug terminal (174) (output "10") must be left free.



CAUTION

TAKE CARE NOT TO SWAP THE TWO GROUND LUG TERMINALS

TABLE ZQ - CONNECTORS FOR INTAKE DUCT CONTROL UNIT AND INTAKE DUCT MOTOR (if available)

The "Intake duct mot." (output "32") connector (167) must be fastened with a small black clamp (170) as shown in the figure.

167. Intake duct motor connector (output "32")

168. Cable harness routing

169. Intake duct motor cable harness connection (output "32")

170. Clamp

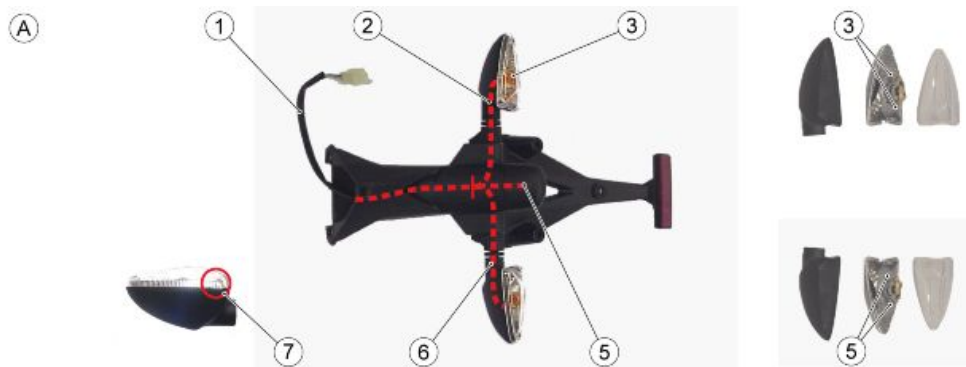
Back side

TABLE A - LICENSE PLATE FRAME PRE-FITTING

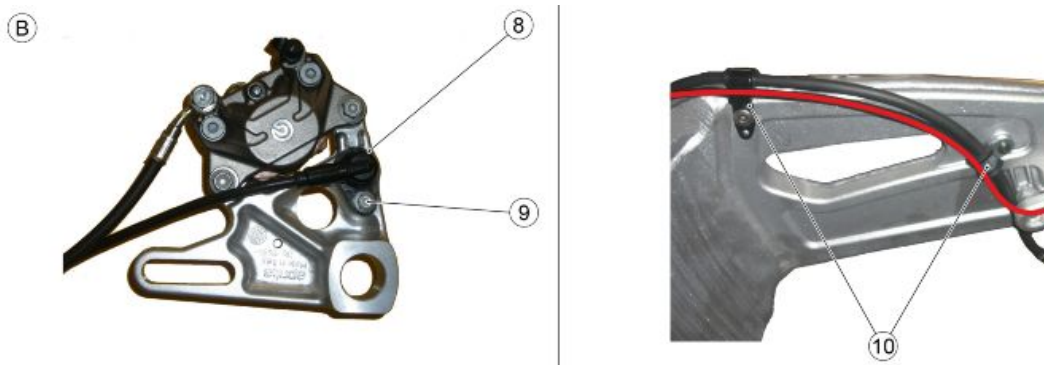
Check that the drainage hole (7) for the water of both turn indicators is positioned downward.

1. License plate frame cable harness
2. Right rear turn indicator cable harness routing
3. 2.8 mm (0.11 in) Faston - cable colours: red and blue
4. License plate light grey rubber ring
5. 2.8 mm (0.11 in) Faston - cable colours: light blue and blue
6. Left rear turn indicator cable harness routing

7. Breather

**TABLE B - SPEED SENSOR PRE-FITTING**

- 8. Speed sensor
- 9. TE M6x20 screw
- 10. Sensor cable harness routing in the cable grommet

**TABLE C - START-UP RELAY PRE-FITTING**

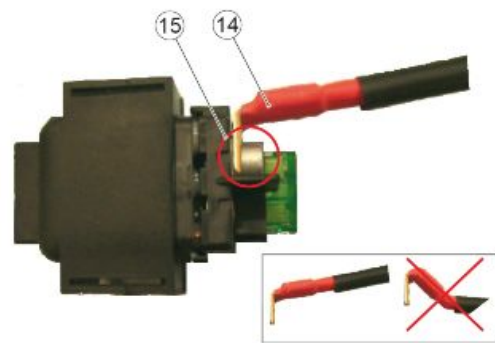
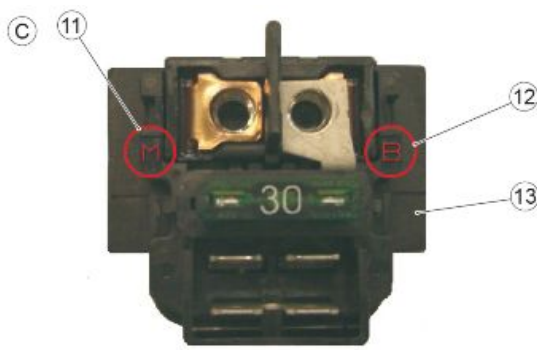
- 11. Starter motor cable on the vehicle cable harness
- 12. Positive battery cable
- 13. Start-up relay
- 14. Positive battery cable
- 15. M5x8 screw

The positive battery cable (14) must be connected with a screw (15) on the hole marked with the letter B (battery).

M=starter motor

B=battery

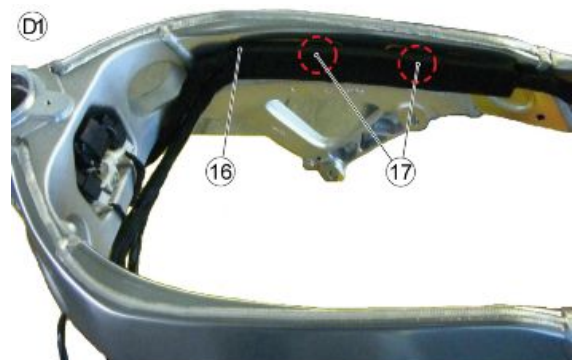
Be careful not to bend the positive battery cable (14).



**TABLES D1 and D2 - VEHICLE CABLE HAR-
NESSES**

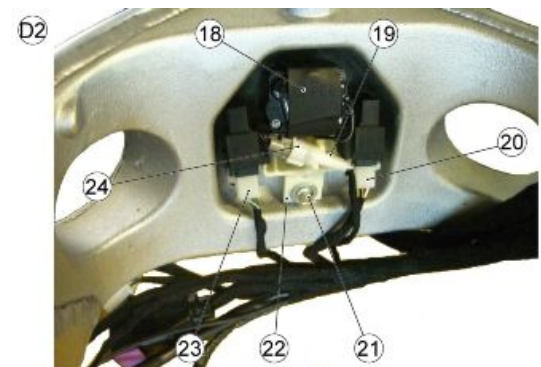
The Vehicle Cable Harness (16) and the "Relay and Fall Sensor" mounting (18) must be fit on the chassis before fitting the engine.

Check that the fan relay (20), safety relay (23) and fall sensor (19) are connected correctly (fit on the relative mounting).



16. Vehicle cable harness

17. Insert two tape clamps on the rigid section of the cable harness in the two holes on the right chassis beam



18. Fall sensor and relay mounting

19. Fall sensor connector

20. Fan relay connector

21. TE M6x20 screw

22. T-shaped bushing

23. Safety relay connector

24. Fasten the fall sensor connector on the mounting link

TABLE E1 - REAR SWINGARM AREA

25. Rubber clamp

26. Rear brake switch cable harness

27. Speed sensor cable harness



TABLE E2 - REAR STOP SWITCH AND SPEED SENSOR CABLE HARNESS ROUTING ON THE RIGHT SIDE

- 28. Cable grommet
- 29. Speed sensor cable harness
- 30. Rear brake switch cable harness

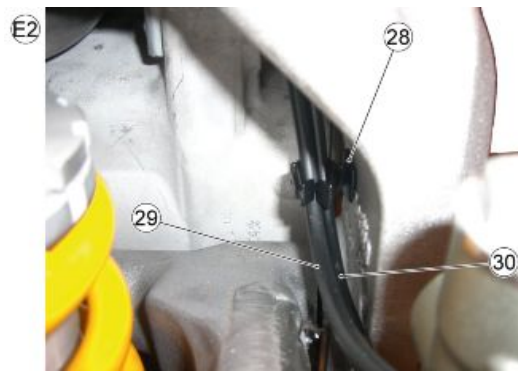


TABLE F1 - REAR SADDLE MOUNTING AREA

- 31. License plate frame cable harness connector
- 32. License plate frame cable harness routing
- 33. Taillight connector
- 34. Taillight



TABLE F2

- 35. Insert the fuse-box in the two tongues on the battery mounting bracket
- 36. Protection relay and relay socket rubber ring
- 37. Insert the relay in the plastic tongue on the left
- 38. TBEI M5x16 screw
- 39. Battery mounting bracket
- 40. TBEI M5x16 screw
- 41. Insert the relay in the plastic tongue on the right
- 42. Relay and relay socket rubber ring



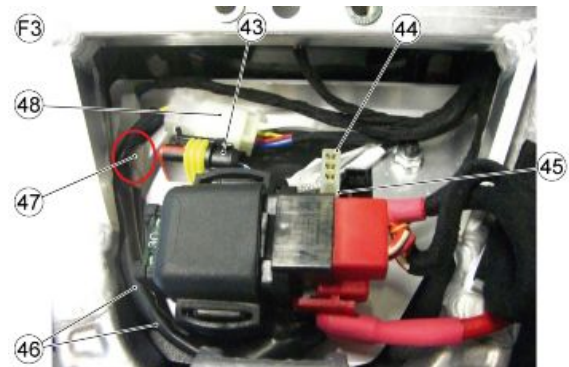
TABLE F2 BIS

- Pass the positive battery cable under the top of the frame.

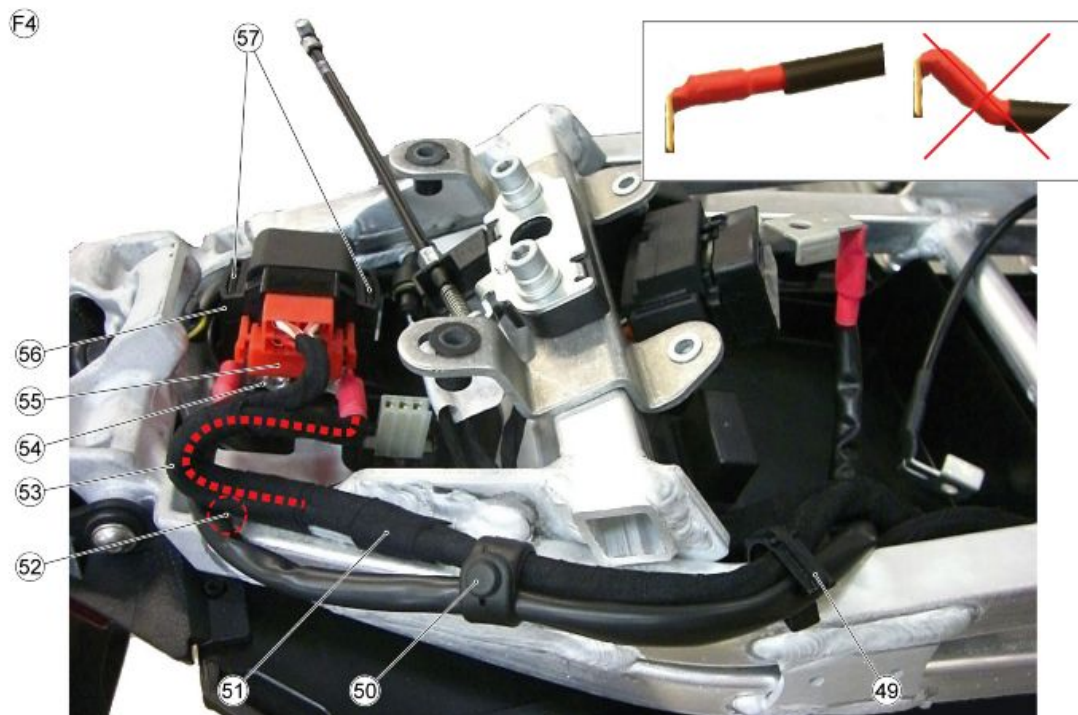


TABLE F3

- 43. ECU diagnosis connector
- 44. Instrument panel diagnosis connector
- 45. Insert the instrument panel diagnosis and the ECU diagnosis connectors in their specific seats
- 46. License plate frame and taillight cable harness routing
- 47. Taillight connector
- 48. License plate frame cable harness connector

**TABLE F4**

- 49. Cable grommet
 - 50. Rubber clamp
 - 51. Vehicle cable harness
 - 52. Insert the tape clamp on the cable harness in the hole on the right side of the saddle mounting
 - 53. Starter motor cable
 - 54. M5x8 screw
 - 55. Start-up relay connector
 - 56. Start-up relay
 - 57. Insert the start-up relay in the two plastic tongues
- Pay attention not to bend the starter motor cable

**TABLE F5 - RIGHT SIDE SADDLE MOUNTING**

Outer

58. Fuel pump connector

59. Insert the tape clamp on the cable harness in the hole on the right side of the saddle mounting

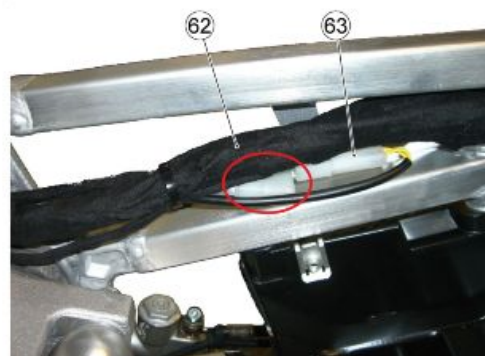
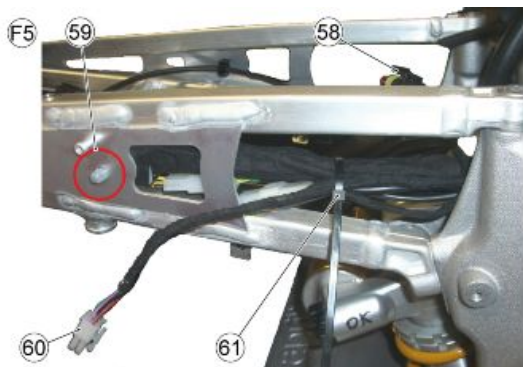
60. variable length intake duct control unit connector

61. Clamp

Inner

62. Speed sensor connector

63. Rear brake switch connector

**TABLE F6 - LEFT SIDE SADDLE MOUNTING**

64. Battery - engine ground lead

65. Cable grommet

**TABLE G - INTAKE DUCT CONTROL UNIT AND TANK**

After fitting the tank and connecting the fuel line push fitting, the fuel pump connector (66) can be connected and positioned as shown in the figure.

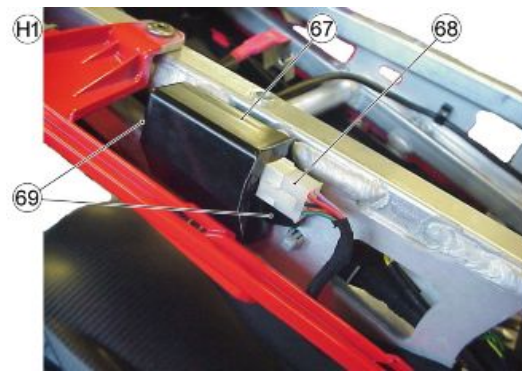
No clamps are necessary.

66. Fuel pump connector

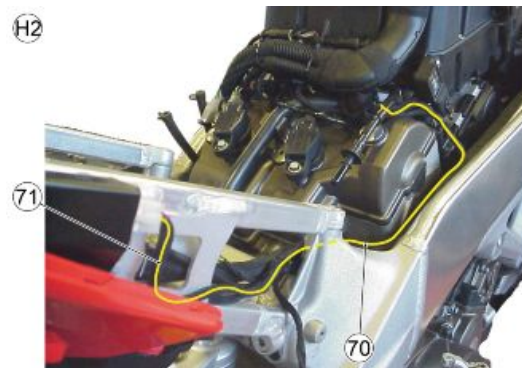


TABLE H1

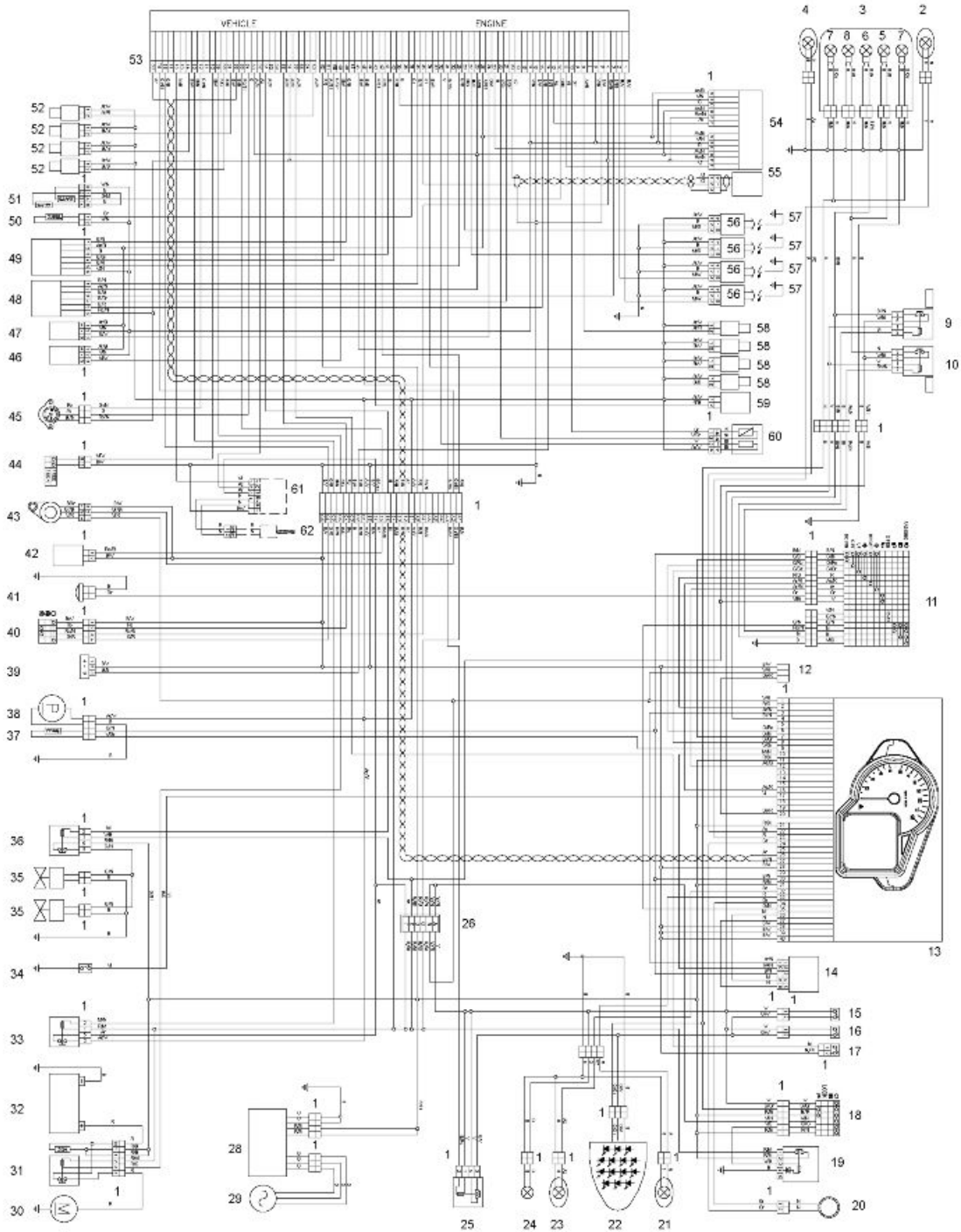
- 67. Intake duct control unit
- 68. Intake duct control unit connector
- 69. Rubber ring

**TABLE H2**

- 70. Clamp
- 71. Intake duct control unit cable harness routing



General wiring diagram



KEY:

- 1. MULTIPLE CONNECTORS
- 2. FRONT RIGHT TURN INDICATOR
- 3. HEAD LIGHT ASSEMBLY
- 4. FRONT LEFT TURN INDICATOR

5. RIGHT LOW-BEAM LIGHT BULB
6. HIGH-BEAM BULB
7. TAIL LIGHT BULB
8. LEFT LOW-BEAM LIGHT BULB
9. HIGH-BEAM LIGHT RELAY
10. LOW-BEAM LIGHT RELAY
11. LEFT LIGHT SWITCH
12. INSTRUMENT PANEL DIAGNOSIS
13. MATRIX II INSTRUMENT PANEL
14. OUTLET VALVE MOTOR
15. FRONT STOP SWITCH
16. REAR STOP SWITCH
17. CLUTCH SWITCH
18. KEY SWITCH
19. PROTECTION RELAY
20. IMMOBILIZER AERIAL
21. REAR RIGHT TURN INDICATOR
22. REAR LIGHT ASSEMBLY
23. REAR LEFT TURN INDICATOR
24. LICENSE PLATE LIGHT BULB
25. RECOVERY LOGIC RELAY
26. AUXILIARY FUSES
27. -
28. VOLTAGE REGULATOR
29. GENERATOR
30. STARTER MOTOR
31. START-UP RELAY
32. BATTERY
33. MAIN INJECTION RELAY
34. OIL PRESSURE SENSOR
35. FAN
36. FAN CONTROL RELAY
37. FUEL RESERVE SENSOR
38. FUEL PUMP
39. ECU DIAGNOSIS
40. RIGHT LIGHT SWITCH
41. HORN
42. FALL SENSOR

-
- 43.SPEED SENSOR
 - 44.SIDE STAND SWITCH
 - 45.GEAR SENSOR
 - 46.FRONT CYLINDERS PRESSURE SENSOR
 - 47.REAR CYLINDERS PRESSURE SENSOR
 - 48.FRONT CYLINDERS THROTTLE VALVES
 - 49.REAR CYLINDER THROTTLE VALVES
 - 50.AIR TEMPERATURE SENSOR
 - 51.WATER TEMPERATURE SENSOR
 - 52.TOP INJECTORS
 - 53.75M CONTROL UNIT
 - 54.EFG 1X THROTTLE CONTROL UNIT
 - 55.REVOLUTION SENSOR
 - 56.COIL
 - 57.SPARK PLUG
 - 58.BOTTOM INJECTORS
 - 59.SECONDARY AIR
 - 60.LAMBDA PROBE
 - 61.VARIABLE GEOMETRY ECU (OPTIONAL)
 - 62.VARIABLE GEOMETRY ENGINE (OPTIONAL)
-

Checks and inspections

GENERAL CONCEPTS OF ELECTRICAL TROUBLESHOOTING

THE CONNECTION DIAGRAMS ARE IN THE ELECTRICAL SYSTEM SECTIONS; PAY ATTENTION TO THESE DIAGRAMS AS THEY SHOW THE CONNECTOR/COMPONENT AS VIEWED FROM THE CABLE HARNESS SIDE, THAT IS LOOKING AT THE CABLES WHEN GOING OUT OF THE "MAIN" CABLE HARNESS AND INTO THE CONNECTOR/COMPONENT.

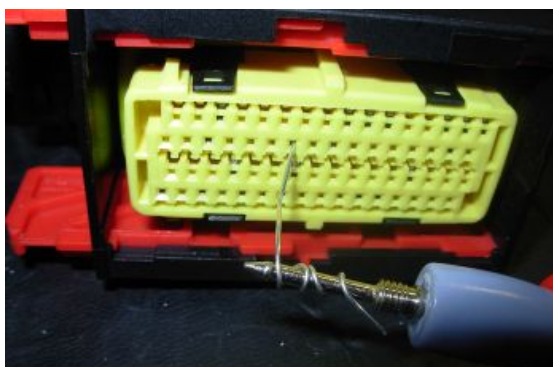
CAUTION

BEFORE CARRYING OUT ANY TROUBLESHOOTING PROCEDURE ON THE VEHICLE, CHECK THAT THE BATTERY VOLTAGE IS ABOVE 12V.

CONNECTOR CHECK PROCEDURE

The procedure includes the following checks:

1. Observation and check of the connector correct position on the component or on the coupling connector, making sure that the locking catch is released.
2. Observation of the terminals on the connector: no rust marks or dirt should be present and it is



important to check terminal correct positioning on the connector (i.e., all terminals aligned at the same depth) and terminal integrity (i.e., that terminals are not loose, open/bent, etc.). For connectors whose terminals are not visible (e.g. Marelli control unit) use a metal cable of suitable diameter and introduce it carefully in the connector slot at the same depth as for the other terminals of the connector.

CAUTION

IN CASE OF TEMPORAL MALFUNCTIONING, CARRY OUT ALL DUE CHECKS LOOKING FOR FAULT BY MOVING SLIGHTLY THE CABLE HARNESS BEING INSPECTED.

3. Pulling the cables slightly from the back of the connector in order to check the correct position of terminals on the connector and of the cable on the terminal.

CONTINUITY check

Check goal: this control is to check that there are not any circuit interruptions nor excessive resistance, for instance caused by rust, on the two terminals being inspected.

Tester: set the tester on the "continuity" symbol and place the tester probes on the two circuit ends: the tester emits a sound signal only if there is continuity; the tester can also be set to the Ohm symbol to check that the circuit resistance is null or a few tenths of an Ohm.

CAUTION: THE CIRCUIT SHOULD NOT BE ENERGISED, OTHERWISE THE TEST IS IRRELEVANT.

GROUND CONNECTION check

Check goal: this control is to check if a cable or a circuit is in contact with the vehicle ground (-) connection.

Tester: set the tester on the "continuity" symbol and place one tester probe on the vehicle ground connection (or on the battery - terminal) and the other probe on the cable being inspected: the tester sends out a sound signal only if there is continuity. The tester can also be set to the Ohm symbol to check that the circuit resistance is null or a few tenths of an Ohm.

CAUTION! IF THERE IS A GROUND CONNECTION COMING FROM THE CONTROL UNIT, MAKE SURE THAT DURING THE TEST THE CONTROL UNIT IS GROUND CONNECTED TO THE CIRCUIT.

VOLTAGE check

Check goal: this control is to check if a cable is energised, i.e. if it receives power supply from the battery or the control unit.

Tester: set the tester on the direct current symbol and place the tester red probe on the cable being inspected and the black probe on the vehicle ground connection (or on the battery - terminal).

CAUTION

IN CASE OF TEMPORAL MALFUNCTIONING, CARRY OUT ALL DUE CHECKS LOOKING FOR FAULT BY MOVING SLIGHTLY THE CABLE HARNESS BEING INSPECTED.

Immobiliser

System components

Function

detects the transponder code in the key and sends it to the instrument panel

Level in electrical circuit diagram:

Immobilizer

Location:

- on the vehicle: in the ignition switch assembly
- connector: two-way, black, inside the bow

Electrical specifications

- 14 Ohm

Pin out

not significant

CAUTION

BEFORE CARRYING OUT ANY TROUBLESHOOTING, CAREFULLY READ THE GENERAL TROUBLESHOOTING CONCEPTS FOR ELECTRICAL DEVICES AT THE BEGINNING OF THE CHECK AND CONTROL SECTION IN THE ELECTRICAL SYSTEM CHAPTER.

INSTRUMENT PANEL: ERRORS

DSB 01 Immobilizer fault

- key code read but not recognised

Error cause

- The read code is not stored in the instrument panel memory

Troubleshooting

- Carry out key data storage procedure

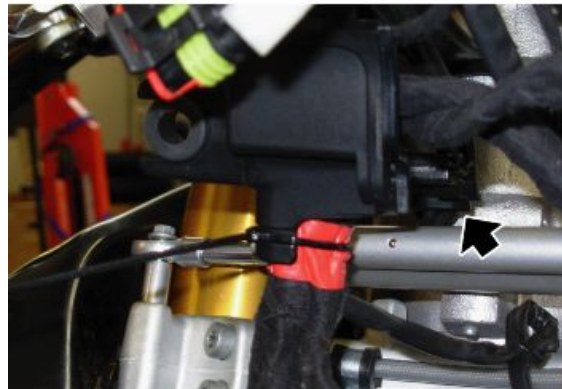
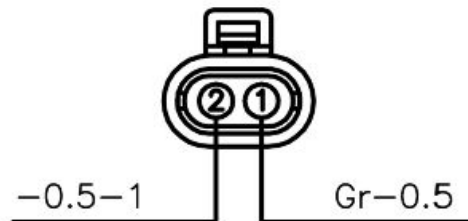
DSB 02 Immobilizer fault

- read key code not read (key not present or transponder not working)

Error cause

- Key transponder does not communicate its own code

Troubleshooting



- Replace the key

DSB 03 Immobilizer fault

- Immobilizer fault: aerial not working (open or short-circuited)

Error cause

- An electric interruption or a ground short circuit or voltage to the circuit have been detected

Troubleshooting

- Check the sensor connector on the cable harness and the instrument panel connector. If not OK, restore; if OK, check electrical characteristics and aerial circuit continuity from the instrument panel connector on PIN 24 and 34: if not OK, restore cable harness; if OK, check circuit ground insulation: if not ground insulated, restore cable harness; if insulated, with key ON, with instrument panel connector disconnected, check that there is not voltage at the circuit ends: if there is voltage, restore the cable harness

DSB 04 Internal controller faultError cause

- There is a fault in the instrument panel

Troubleshooting

- Replace the instrument panel
-

Dashboard

In case of doubts in operation of the engine revs indication, it is possible to connect the vehicle to the diagnostics instrument and activate the engine revs indication choosing the function "Rpm indicator" from the "Devices Activation" screen page (injector icon)

Installing a new instrument panel

In case the instrument panel is replaced by a new one, follow the procedure shown below so that the immobilizer system (key storage) and the exhaust butterfly valve (controlled by the ECU through the instrument panel) operate correctly.

1. Request all the keys of the vehicle in the customer possession.

Once the instrument panel is electrically connected to the vehicle and a key is set to ON, the key is stored and the instrument panel waits for 20 seconds for a possible second key. If there is a second key, remove the first key and wait for the storage of the second key. When the second key storage is complete, the instrument panel waits for another key up to a maximum of 4 total keys or the procedure will be interrupted after 20 seconds.

At this stage, the instrument panel turns on as usual.

2. Deleting the errors stored by the instrument panel: select Menu and then Diagnosis. An access code is required to enter this menu:

12412

Then, select the option: "Delete errors"

NOTE

DELETE THE ERROR CAUSED BY THE LACK OF MEMORY OF KEY CODES.

3. Connect to the vehicle with the diagnosis tool and select the adjustable Parameters in the screen page:

"Exhaust butterfly valve self-acquisition"

NOTE

SEARCH FOR MINIMUM AND MAXIMUM MECHANICAL STOPS STORED IN THE INSTRUMENT PANEL.

In case of a correct self-acquisition, the procedure is finished.

If the self-acquisition is not performed correctly, follow the procedure "Exhaust butterfly valve calibration" as shown in the section: Electrical system, Checks and controls, Exhaust butterfly valve.

See also

[Butterfly valve in exhaust](#)

Diagnosis

An access code is required to enter this menu which controls the diagnosis function:

- ENTER SERVICE CODE

This is a 5-digit code, fixed for each vehicle. For these vehicles, the code is:

12412

If the code is incorrect, the following message is displayed:

- INCORRECT CODE

and the instrument panel goes back to the main menu. Otherwise, the following menu is displayed:

- Exit
- INSTRUMENT PANEL ERRORS
- Error Clearing
- VEHICLE SERVICING RESET
- Update
- CHANGE KEYS
- KM / MILES

INSTRUMENT PANEL ERRORS

In this mode, a chart is displayed showing potential errors in the immobilizer and the sensors connected to it.

ERRORI CRUSCOTTO		
	ACTIVE	MEMO
DSB 01	0	0
DSB 02	0	X
DSB 03	X	X
DSB 04	0	X
DSB 05	0	0
DSB 06	0	X

Instrument panel errors

In this mode, a chart is displayed showing potential errors in the immobilizer and the sensors connected to it.

DSB 01 - Immobilizer fault: key code read but not recognised.

DSB 02 - Immobilizer fault: key code not read (key not present or transponder not working)

DSB 03 - Immobilizer fault: aerial not working (open or short-circuited)

DSB 04 - Internal controller fault

DSB 05 - -

DSB 06 - -

Error cause

- An oil sensor fault is signalled when it is detected that the sensor circuit is open or shorted to positive.

DSB 07 - Oil pressure sensor

Error cause

An oil sensor fault is signalled when, with engine off, it is detected that the sensor circuit is open.

Troubleshooting

The test is performed only once when the key is set to ON. This error is signalled by the bulb icon, and the general warning light turns on as well.

DSB 08 - Oil pressure sensor

Error cause

An oil sensor fault is signalled when, with engine running, it is detected that the sensor circuit is closed. There is an error when the general warning light turns on.

Troubleshooting

This error is signalled by the bulb icon, and the general warning light turns on as well.

The instrument panel must keep all previous errors stored in its memory.

DELETE ERRORS

This option deletes all instrument panel errors; a further confirmation is requested. Use Navigator to reset ECU errors.

VEHICLE SERVICING RESET

This function is used to reset vehicle servicing. Using this function, the odometer can be reset only once within the first 200 km (124 mi) of the vehicle, provided this has not been done by the Quality Check.

UPDATE

This function is used to program the instrument panel again. This screen page shows the software version currently loaded; the LCD reads:

- INSTRUMENT PANEL DISCONNECTED. NOW CONNECT THE DIAGNOSIS INSTRUMENT.

The instrument panel will restart to work normally after the key is inserted-extracted.

Modify Keys

With this function the instrument panel can update the keys. Up to 4 keys can be stored.

The user code is first requested to be entered:

- ENTER THE CODE

After entering the correct code, the following message should be shown on the display:

- INSERT THE X KEY
- INSERT THE X+1 KEY

At least one key must be programmed for the next start-ups. If no other key is inserted within 20 seconds or if there is no power or after the fourth key is programmed, the procedure finishes and all the functions of the vehicle and the instrument panel must be enabled (even if only one key has been programmed).

KM / MILES

This menu selects the unit of measurement, either for the speed or the total or partial odometers.

- KM
- MILES

LANGUAGES

Select the user interface language from this menu.

- ITALIANO
- ENGLISH
- FRANCAIS
- DEUTSCH
- ESPAÑOL

Service warning light reset

VEHICLE SERVICING RESET

This function is used to reset vehicle servicing. Using this function, the odometer can be reset only once within the first 200 km (124 mi) of the vehicle, provided this has not been done by the Quality Check.

In order to activate this function follow the instructions in the DIAGNOSIS section.

See also

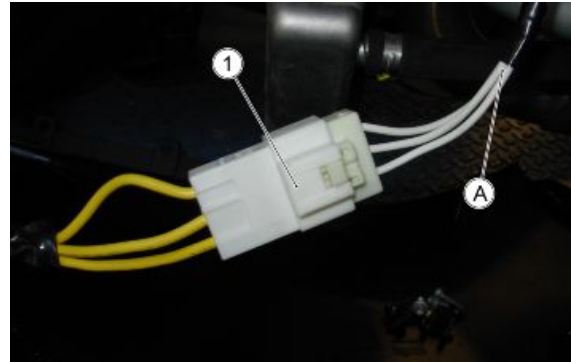
Diagnosis

Battery recharge circuit**RECHARGE SYSTEM (Mitsubishi - Kokusan)**

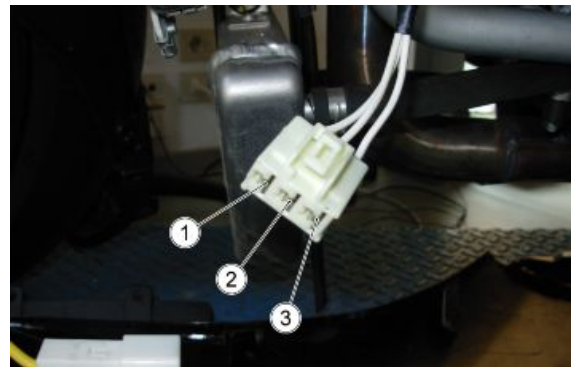
- Remove the left side fairing;
- Disconnect the three-way connector (1) (white).

NOTE

THE ENGINE SIDE IS IDENTIFIED WITH THE LETTER "A"

**Measurement of resistance (with engine off)**

- For a correct detection of the alternator resistance, an ambient temperature measurement must be carried out and afterwards a heat stabilisation (after turning fan on) by using a tester, using alternatively the 3 connector pins: stage "1" (pin 1-2), stage "2" (pin 1-3), stage "3" (pin 2-3).



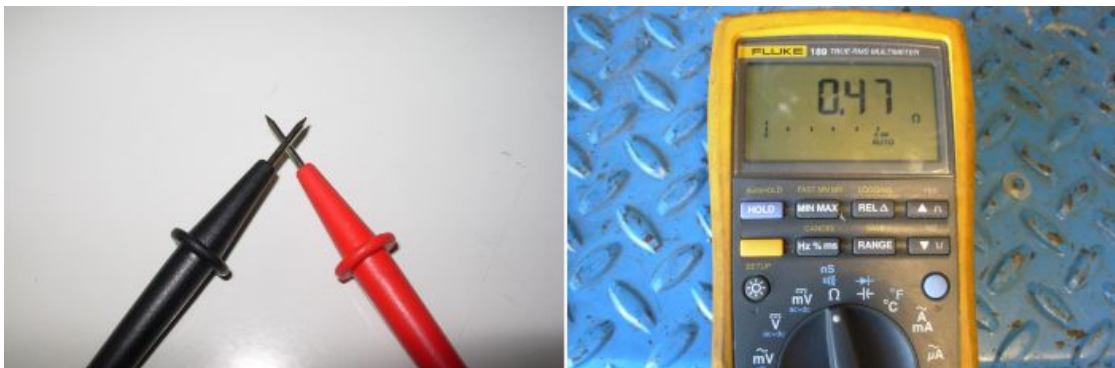
- Take the measurement; The correct value is determined by the value measured for each stage in which from time to time the resistance of the tester wires is subtracted, obtained by touching the two lugs.

Example:

- Resistance of stage 1 read on the display = 0.62 Ohm



- Resistance of the wires read on the display = 0.47 Ohm



- Effective resistance stage 1 = $0.62 - 0.47 = 0.15$ Ohm
- If there is a significant difference between one stage and another (other than 0.15 Ohm), this means that the alternator is defective and must be replaced.

RESISTANCE MEASURE (KOKUSAN FLYWHEEL)

Winding stage	Ambient temperature (ohm)	Afterwards heat stabilisation (ohm)
Stage 1	0.15 - 0.20	0.25 - 0.30
Stage 2	0.15 - 0.20	0.25 - 0.30
Stage 3	0.15 - 0.20	0.25 - 0.30

RESISTANCE MEASURE (MITSUBISHI FLYWHEEL)

Winding stage	Ambient temperature (ohm)	Afterwards heat stabilisation (ohm)
Stage 1 - 2	0.10 - 0.15	0.15 - 0.20
Stage 1 - 3	0.10 - 0.15	0.15 - 0.20
Stage 2 - 3	0.10 - 0.15	0.15 - 0.20

Empty voltage

- Disconnect the three-way connector (1);
- For a correct detection of the alternator voltage, a measurement must be carried out using alternatively the 3 engine side connector pins: stage "1" (pin 1-2), stage "2" (pin 1-3), stage "3" (pin 2-3).
- Take the measurements;

- If there is a significant difference between one stage and another (other than 15 V), this means that the alternator is defective and must be replaced.

CAUTION

WITH THE ENGINE HOT THE VALUES RECORDED ARE ON AVERAGE 4-5 V LESS THAN THOSE DETECTED WITH THE ENGINE COLD.

EMPTY VOLTAGE (KOKUSAN FLYWHEEL)

rpm	2000	4000	6000	8000
Vm linked voltage Reference values (V rms)	22 - 27	46 - 51	69 - 74	92 - 97

EMPTY VOLTAGE (MITSUBISHI FLYWHEEL)

rpm	2000	4000	6000	8000
Vm linked voltage Reference values (V rms)	31 - 36	63 - 68	93 - 98	121 - 126

Short circuit current

- For a correct detection of the short circuit current, a connector must be prepared that generates a downstream short circuit between the three alternator cables;
- Start the engine and with an ammeter clamp measure each single cable.
- If there is a significant difference between the measure of the single cables (other than 10 A), this means that the alternator is defective and must be replaced.

**CAUTION**

WITH THE ENGINE HOT THE VALUES RECORDED ARE ON AVERAGE 2-3 A LESS THAN THOSE DETECTED WITH THE ENGINE COLD.

WARNING

NEVER KEEP THE ENGINE RUNNING FOR MORE THAN ONE MINUTE; FAILURE TO DO SO COULD CAUSE SERIOUS OVERHEATING DAMAGES TO THE MOTORCYCLE CIRCUITS.

COLD SHORT CIRCUIT CURRENT (KOKUSAN FLYWHEEL)

RPM	2000	4000	6000	8000
RMS DC current (Arms) (average of the 3 stage currents)	22 - 27	22 - 27	22 - 27	22 - 27

COLD SHORT CIRCUIT CURRENT (MITSUBISHI FLYWHEEL)

RPM	2000	4000	6000	8000
RMS DC current (Arms) (average of the 3 stage currents)	22 - 27	22 - 27	22 - 27	22 - 27

Voltage on battery poles with engine speed always between 3000 - 5000 RPM

- Start the engine, after about one minute of operating bring the speed to 3000-5000 RPM, then measure with a tester the voltage at the battery poles that must always be between 13V and 15V. Otherwise, if the correct operation of the alternator has already been checked, replace the regulator.

CAUTION

PERFORM THE CHECK DESCRIBED ABOVE WITH A BATTERY IN GOOD CONDITION (START VOLTAGE ABOUT 13V) MAKING SURE THAT THERE ARE NO ELEMENTS IN THE SHORT CIRCUIT.

Start-up system check

Function

Communicates to the control unit the will to start-up the engine.

Operation / operating principle

Press the start-up button to close the specific circuit taking the PIN 58 of the control unit to a voltage equal to zero (ground closing).

Level in wiring diagram:

Start-up signal

Location:

- on the vehicle: right light switch.
- connector: inside the bow (4-ways black).

Electrical characteristics:

- key released: the circuit is open
- key pressed: the circuit is closed

Pin out:

2: voltage + 5V

3: ground

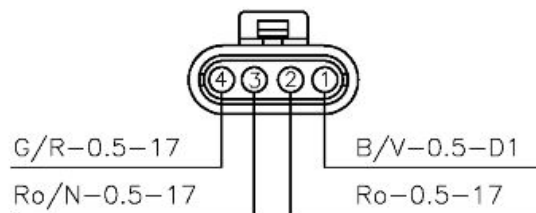
CAUTION

BEFORE CARRYING OUT ANY TROUBLESHOOTING, CAREFULLY READ THE GENERAL TROUBLESHOOTING CONCEPTS FOR ELECTRICAL DEVICES AT THE BEGINNING OF THE CHECK AND CONTROL SECTION IN THE ELECTRICAL SYSTEM CHAPTER.

DIAGNOSTICS INSTRUMENT: ELECTRICAL ERRORS

Starter switch P0170

- shorted to positive / open circuit, shorted to negative.

Error cause

- If shorted to positive: excessive voltage has been detected at PIN 58; if the circuit is open, shorted to negative: voltage equal to zero has been detected.

DIAGNOSTICS INSTRUMENT: LOGIC ERRORS

Starter switch P0169

- signal not valid.

Error cause

- Fault in the switch (lock) of the engine start-up. The instrument panel does not indicate the presence of this error even in the ATT status.

Troubleshooting

- Check the locking cause and restore.

level indicators

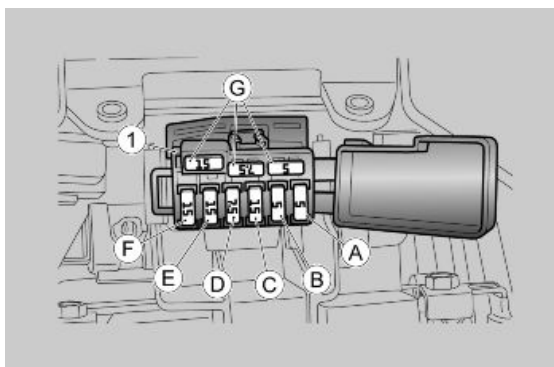
See also

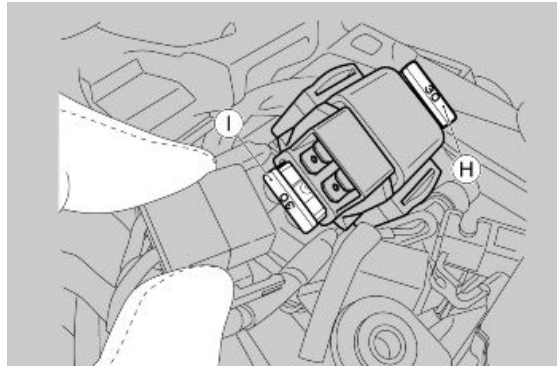
Fuel pump

Fuses

SECONDARY FUSES DISTRIBUTION

Specification	Desc./Quantity
A) 5A fuse	Stop and running lights relay
B) 5A fuse	Instrument panel, turn indicators, speed and instrument panel diagnostics.
C) 15A fuse	Control unit
D) 7.5A fuse	Control unit
E) 15A fuse	High-beam light/low-beam light, horn and fans
F) 15A fuse	Coils, injectors, fuel pump, oxygen sensor and secondary air valve



**CAUTION**

THERE ARE THREE SPARE FUSES (G).

CAUTION

THERE IS ONE SPARE FUSE (H).

MAIN FUSES DISTRIBUTION

Specification	Desc./Quantity
I) 30A fuse	Battery recharge and vehicle current consumers, injection current consumers (red and red/white cables).

Control unit

Removal

- Remove the fuel tank.
- Disconnect both control unit connectors



- Unscrew and remove the three screws.
- Remove the control unit.

**NOTE**

WHEN REFITTING THE CONNECTORS, THE SLIDES MUST MOVE FREELY TO THE END OF STROKE, WHICH HELPS WITH THE INSERTION OF THE CONNECTOR: YOU MUST HEAR THE RELEASE OF THE RETAINING TANG AT THE END OF STROKE.

CONTROL UNIT - Diagnosis

Function

it controls the Ride by wire system, the injection/ignition, the system safety checks and the self-diagnosis function

Level in electrical circuit diagram:

Each level in which the main component involves the control unit

Location:

- on the vehicle: above the filter box
- connector: on connector control unit of ENGINE PIN 52 (figure A), connector of ENGINE PIN 28 (figure B)

Pin out: See the CONNECTORS section

DIAGNOSTICS INSTRUMENT: PARAMETERS

ISO Screen page

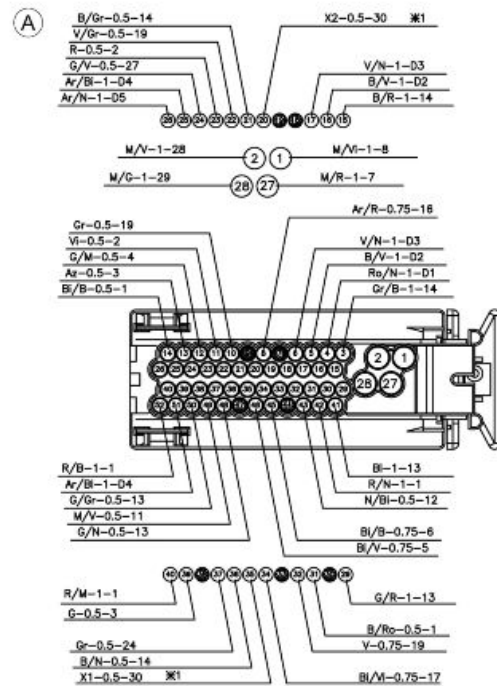
(screen/example value with key set to ON)

- Drawing number / -
- Marelli spare part code / IAW7SMHW430
- Hardware number / 00
- Mapping / -
- Software version number / 0000
- Type-approval Code / -
- ISO Code / -
- Marelli software code / -
- Control unit series number (NIP) / 7SMPRA119 - Identifies the single control unit
- Person in charge for last programming / - Indicates the series number of the DIAGNOSTICS INSTRUMENT that has carried out the last control unit remapping

DIAGNOSTICS INSTRUMENT: PARAMETERS

Nominal idle speed

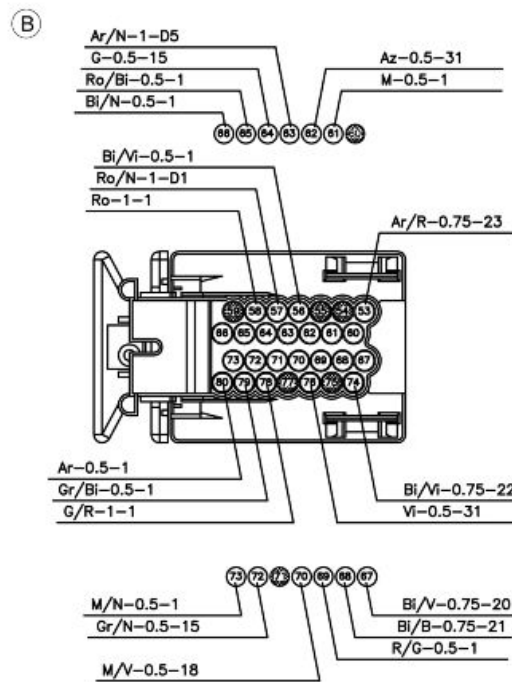
- Example value with key ON: 1600 rpm



Adjustable fuel supply
Adjustable fuel correction

CAUTION

BEFORE CARRYING OUT ANY TROUBLESHOOTING, CAREFULLY READ THE GENERAL TROUBLESHOOTING CONCEPTS FOR ELECTRICAL DEVICES AT THE BEGINNING OF THE CHECK AND CONTROL SECTION IN THE ELECTRICAL SYSTEM CHAPTER.



DIAGNOSTICS INSTRUMENT: STATUSES

Engine status

- Indefinite_Key ON_Running engine_Stopped_Power latch_Power latch 2_Power latch finished

Engine mode

- Indefinite_Start-up_Stable_Idle_Acceleration_Deceleration_Enters Cut Off_Cut Off_Exits Cut Off

Immobilizer signal

- yes/no
- Indicates whether the control unit has received the consent by the instrument panel regarding the immobilizer: coded key or user code entered manually. Potential errors will be shown on the Instrument Panel Errors screen page, on the DIAGNOSIS section of the instrument panel

Start up enabling

- yes/no
- Indicates whether the control unit will enable start-up when requested: in case the safety measures are not respected (side stand, neutral sensor and clutch in correct position) or the fall sensor is inverted or if the immobilizer does not send the start-up consent to the control unit, the status is NO

DIAGNOSTICS INSTRUMENT: ACTIVATION

Stop light

- The stop light logic relay (No 25 in the wiring diagram, position in the front niche of the frame, right side, CHECK, however, the identification of the relay with the colour of the cables) is energised

Error clearing

Ambient parameter reading

- Rear throttle target position angle
- Front throttle target position angle
- Rear throttle position
- Front throttle position
- Engine Temp. before Recovery
- Rear cylinder mean intake pressure (1 and 3)
- Front cylinder mean intake pressure (2 and 4)
- Engine rpm
- Indicated average torque
- Engine status - Indefinite_Key ON_Running engine_Stopped_Power latch_Power latch 2_Power latch finished
- Odometer
- Mapping selection - Indefinite/Track/Sport/Road

DIAGNOSTICS INSTRUMENT: ELECTRICAL ERRORS

EEPROM Error P0601

- circuit not operational

Error cause

- Replace injection ECU. The instrument panel does not indicate the presence of this error even in the ATT status

RAM Error P0604

- circuit not operational

Error cause

- Replace injection ECU. The instrument panel does not indicate the presence of this error even in the ATT status

ROM Error P0605

- circuit not operational

Error cause

- Replace injection ECU. The instrument panel does not indicate the presence of this error even in the ATT status

A/D converter P0607

- circuit not operational

Error cause

- Replace injection ECU

Stop lights relay error P0610

- short circuit to positive/ short circuit to negative / open circuit

Error cause

- If shorted to positive: excessive voltage has been detected at PIN 31. If shorted to negative: no voltage has been detected. If the circuit is open: an interruption has been detected

Troubleshooting

- If shorted to positive: check the relay electrical specifications are correct by disconnecting it from the cable harness. If they are not correct, replace the relay; if OK, restore the cable harness (Blue/Pink cable)
- If shorted to negative: check the relay electrical specifications are correct by disconnecting it from the cable harness. If they are not correct, replace the relay; if OK, restore the cable harness (Blue/Pink cable)
- If the circuit is open: check the relay electrical characteristics are correct by disconnecting it from the cable harness; if not OK, replace the relay, if OK, check relay connector, engine-vehicle cable harness connector and ENGINE connector of the Marelli control unit: if not OK, restore; if OK, check continuity of cable harness (Blue/Pink cable)

DIAGNOSTICS INSTRUMENT: LOGIC ERRORS

Level 2 safety reset P0608

Error cause

- As the level 2 safety system (comparison between requested torque and calculated torque) has detected a fault, the control unit has reset engine (C gravity). The instrument panel does not indicate the presence of this error even in the ATT status.

Troubleshooting

- Continue fault search for the other errors detected

Safety Engine Stop P0609

Error cause

- Since the safety system has detected a serious fault, the control unit has shut off the engine

Troubleshooting

- Continue fault search for the other errors detected.

Saved data file (for safety) P0611

- Filled

Error cause

- This indication appears only if the Level 2 safety has reset the engine (C gravity). The instrument panel does not indicate the presence of this error even in the ATT status

Troubleshooting

- Continue fault search for the other errors detected.

DIAGNOSTICS INSTRUMENT: ADJUSTABLE PARAMETERS

Cylinders pressure balance

- It allows balancing the cylinders 1-3 and then the cylinders 2-4 by the by-pass screws

Control unit EEPROM zero setting

CAUTION

DELETING ALL THE SAVED DATA WHEN THE VEHICLE IS BEING MANUFACTURED (INCLUDING THE SELF-ADJUSTABLE PARAMETERS), THEN YOU MUST SELECT: HANDLE SELF-LEARNING AND CHECK THE TWO "AUTOMATIC FRONT THROTTLE SELF-LEARNING" AND "AUTOMATIC REAR THROTTLE SELF-LEARNING" STATUSES ARE "PERFORMED".

See also

[Cylinders synchronisation](#)

Saved data file download

Error cause

- The BUFRSVXX.BIN file is saved in the Navigator memory card or in your hard disk PC, if you are using Piaggio Group Diagnostic Software combined to Navigator: data regarding the control unit serial number and the serial number of the Navigator that has carried out the download is also included in that file

Saved data file deletion

Error cause

- Deletion enabled only if the file is downloaded after setting KEY ON

NEW CONTROL UNIT ACTIVATION PROCEDURE and REPROGRAMMING

After installing the control unit for the first time, or after REPROGRAMMING the control unit with a different or more updated mapping, turn the key to ON and wait 3 seconds; during this time the control unit carries out throttle position acquisition. Connect to diagnosis instrument and check that the statuses "Front throttle automatic self-learning" and "Rear throttle automatic self-learning" are "Carried out" and "Handle self-learning" is "Not carried out" (this last status entails Urgent service being displayed on the instrument panel). If front and rear throttle automatic self-acquisition indicate "Not carried out" go to phase 1, if indicate "Carried out" go to phase 2. Phase 1: current errors have probably been detected by the control unit: solve these malfunctions and check the two statuses. Throttle Self-learning can also be checked from the Parameter adjustment (screwdriver and hammer) screen page. Stage 2: Carry out the Handle Self-learning from the Parameter adjustment (screwdriver and hammer) screen page and check that Handle Self-learning status is Carried out. If not OK the voltage detected on the throttle is

out of scale (check with diagnosis instrument) or current errors have been probably detected by the control unit: solve these malfunctions and repeat the procedure

Battery

Function

Electrically supply the vehicle: battery YTZ 10 S MF is already activated, loaded and sealed; or, alternatively, battery YT 12A - BS, which must be activated and loaded.

Level in electrical circuit diagram:

Battery recharge

Location:

- on the vehicle: under the saddle
- connector: on the battery

Electrical specifications:8.6 Ah

Pin out:

1. Positive pole (red): approx. 12.6 V
2. negative pole (black): ground connection

DIAGNOSTICS INSTRUMENT: PARAMETERS

Battery voltage

- Example value with key ON: 12.0 V
- Example value with engine on: 14.2 V

In case of recovery, this value is set by the control unit

Battery voltage pre Recovery

- Example value with key ON: 12.0 V
- Example value with engine on: 14.2 V

Value drawn from the signal read without taking into account any recovery

CAUTION

BE CAREFUL WITH THE POSITIVE BATTERY CABLE - IT HAS TO GO UNDER THE TOP OF THE FRAME.

CAUTION

BEFORE CARRYING OUT ANY TROUBLESHOOTING, CAREFULLY READ THE GENERAL TROUBLESHOOTING CONCEPTS FOR ELECTRICAL DEVICES AT THE BEGINNING OF THE CHECK AND CONTROL SECTION IN THE ELECTRICAL SYSTEM CHAPTER.

DIAGNOSIS INSTRUMENT: LOGIC ERRORS

Battery voltage P0560



- too high/too low

Error cause

- If too high: too high a voltage has been detected at PIN 42. If too low: too low a voltage has been detected at PIN 42. The instrument panel does not indicate the presence of this error even in the ATT status.

Troubleshooting

- If too high: check correct operation of the voltage regulator.
- If too low: check voltage regulator connectors, engine - vehicle cable harness connector and the control unit connector (paying special attention to possible oxidation): if not OK, restore; if OK, check that red/white cable resistance from the voltage regulator connector to the control unit connector is a few tenths of Ohm: if not OK, restore cable harness; if OK, check correct operation of the electrical alternator: if not OK, restore; if OK, check operation of the voltage regulator

Speed sensor

Function

to indicate the vehicle speed by reading the rear wheel turning speed

Operation / operating principle

Hall-effect sensor: a square-wave pulse is generated with voltage between 10 V and 0 V with metal ground near the sensor V

Level in wiring diagram:

Speed sensor

Location:

- sensor: on rear wheel fork, right side
- connector: on right side rear frame (three-way white connector)

Pin out:

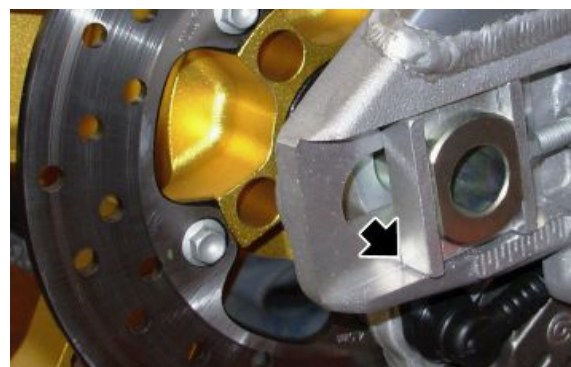
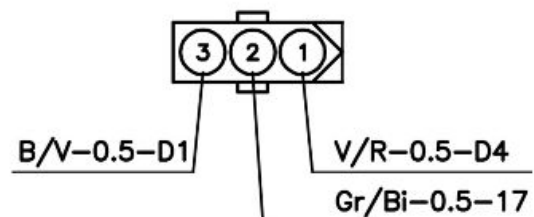
1. Power supply voltage (12V)
2. Output signal
3. Ground connection

DIAGNOSIS INSTRUMENT: PARAMETERS

Vehicle speed:km/h

CAUTION

BEFORE CARRYING OUT ANY TROUBLESHOOTING, CAREFULLY READ THE GENERAL TROUBLESHOOTING CONCEPTS FOR ELECTRICAL DEVICES AT THE BEGIN-



WARNING OF THE CHECK AND CONTROL SECTION IN THE ELECTRICAL SYSTEM CHAPTER.

WARNING

Sensor or its circuit malfunction are not detected by the control unit. In case of incorrect or missing speed indication on the instrument panel, carry out troubleshooting indicated below.

Troubleshooting

Check the speed sensor connector, the engine-vehicle cable harness and the VEHICLE connector of the Marelli control unit, specially at PIN 79: if not OK, restore; if OK, check, with sensor connector disconnected, that there is continuity between PIN 3 and ground: if not, restore cable harness and if there is continuity, check that, with key ON with sensor connector disconnected, there is voltage at PIN 1 (approximately 12 V) : if there is not voltage, set the key to OFF and check continuity between secondary fuse B and PIN 3 and if there is not continuity, restore cable harness; if there is voltage, set the key to OFF and check that there is continuity between the VEHICLE connector PIN 79 and the sensor PIN 2: if there is not continuity, restore the cable harness; if there is continuity, replace the sensor.

Variable geometry intake

(IF AVAILABLE)

Function

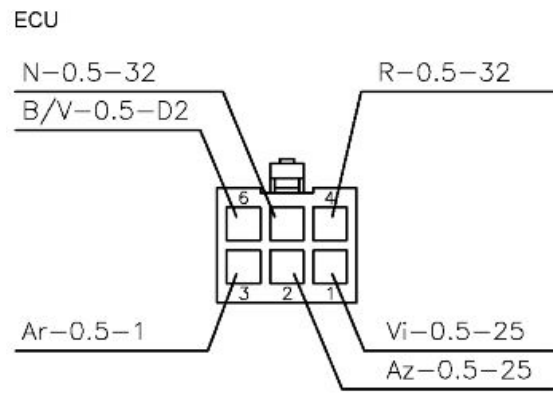
Extend or shorten the engine intake ducts to increase the intake air quantity according to the engine revs.

Operation / Operating principle

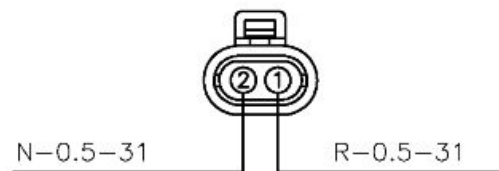
The system consists of:

- two intake ducts for each manifold, which may be joined (long ducts) or separated (short ducts);
- a motor that, by means of an endless screw, activates the upper part of the intake ducts;
- a variable geometry control unit for managing the system, interfaced with the engine injection control unit.

At key-ON, the variable geometry control unit lowers the ducts (if still in the raised position). Subsequently, depending on the control voltage on PIN 2 from the injection control unit (0V down, 5V up), the control unit drives the electric motor with the relative polarity for raising or lowering the ducts.



ENGINE



The drive voltage delivered to the motor is determined in relation to battery voltage and the motor is stopped once a given current limit is reached or if the time-out period of 500 ms has elapsed.

Level in electrical circuit diagram:

Variable geometry

Location:

- on the vehicle: ducts and motor inside the filter box, variable geometry control unit on rear frame under the saddle, right side.
- variable geometry control unit connector: on the control unit.
- connector of the electrical motor cable to the engine cable harness: outside the filter box next to the rear upper injectors.



Electrical specifications:

Electrical motor resistance. 4.5 +/- 0.5 Ω ; PIN 1: 0V normal, Vbatt fault PIN 2: 0V ducts control down, 5V ducts control up.

Pin out:

1. Control unit fault
2. Control from the injection ECU
3. Key ON (Vbatt)
4. Engine +
5. Engine -
6. Ground connection

CAUTION

BEFORE CARRYING OUT ANY TROUBLESHOOTING, CAREFULLY READ THE GENERAL TROUBLESHOOTING CONCEPTS FOR ELECTRICAL DEVICES AT THE BEGINNING OF THE CHECK AND CONTROL SECTION IN THE ELECTRICAL SYSTEM CHAPTER.

DIAGNOSTICS INSTRUMENT: STATUSES

Variable geometry intake

- not active/active

NOTE: It indicates whether the control unit has sent the command to the variable geometry control unit to lift the ducts.

DIAGNOSTICS INSTRUMENT: ACTIVATION

Variable geometry intake control

NOTE: The injection ECU sends the command to the variable geometry control unit to lift the ducts. In the version PGDS 3.0.0 for Navigator, the command works once only, then it is used to take the key to OFF and wait if communication with the control unit is lost.

DIAGNOSIS INSTRUMENT: ERRORS

Variable geometry intake P0447

- shorted to positive / shorted to negative / open circuit / signal not valid.

Error cause

- If shorted to positive: excessive voltage has been detected at PIN 62. If shorted to negative: no voltage has been detected. If the circuit is open: an interruption has been detected. If signal is not valid: PIN 76 detects a battery voltage set by the variable geometry control unit to indicate error detection. The instrument panel does not indicate the presence of this error even in the ATT status.

Troubleshooting

- If shorted to positive: if a voltage higher than 5V is detected, disconnect the variable geometry control unit connector and check with key ON the voltage to PIN 2: if it is higher than 5 V, restore cable harness; if equal to zero, replace the variable geometry control unit.
- If shorted to negative: disconnect the variable geometry control unit connector and the injection ECU connector and check continuity to ground of the light blue cable: if there is continuity with the ground, restore cable harness; if insulated from ground, replace the variable geometry control unit.
- If the circuit is open: check the connector of the variable geometry control unit and the injection control unit: if they are not OK, restore; if they are OK, check continuity on the light blue cable: if not OK, restore; if OK, replace the variable geometry control unit.
- If signal is not valid: check the connector of the variable geometry control unit, the motor cable connector and the motor connector (check the PINS of the connector, installed directly on the motor): if not OK, restore; if OK, check electrical characteristics of the motor: if not OK, replace; if OK, check, with connector of the variable geometry control unit and connector of the motor disconnected and intermediate connector connected, if the red and black cables are in continuity, insulated from ground and without voltage and insulated one from the other: if not OK, restore; if OK, check if the electrical motor pin is correctly inserted in the cavity of the endless screw (however it must turn a bit): if not OK, place it correctly; if OK, replace the variable geometry control unit.

Engine rpm sensor

Function

informs crankshaft position and speed to the Marelli control unit

Operation / Operating principle

inductive sensor: sinusoidal-type generated voltage; two teeth are missing on the flywheel for the reference position

Level in electrical circuit diagram:

Engine speed sensor

Location:

- on the vehicle: on the clutch cover
- connector: under the tank on the right (3-ways black connector)

Electrical specifications:

0.79 kohm at ambient temperature

Pin out:

1. negative signal
2. positive signal
3. shielding with ground connection

DIAGNOSTICS INSTRUMENT: PARAMETERS

Engine rpm: rpm

CAUTION

BEFORE CARRYING OUT ANY TROUBLESHOOTING, CAREFULLY READ THE GENERAL TROUBLESHOOTING CONCEPTS FOR ELECTRICAL DEVICES AT THE BEGINNING OF THE CHECK AND CONTROL SECTION IN THE ELECTRICAL SYSTEM CHAPTER.

DIAGNOSTICS INSTRUMENT: STATUSES

Synchronised panel

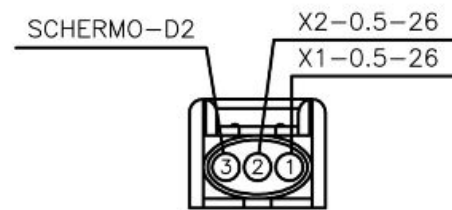
- No_under analysis_standby_Yes

DIAGNOSTICS INSTRUMENT: ELECTRICAL ERRORS

CAUTION

IF THE ELECTRIC CIRCUIT IS INTERRUPTED OR SHORT-CIRCUITED, NO ERROR IS DISPLAYED. CHECK THE ENGINE SPEED SENSOR CONNECTOR AND THE MARELLI CONTROL UNIT CONNECTOR: IF NOT OK, RESTORE; IF OK, CHECK THE CORRECT ELECTRIC CHARACTERISTICS OF THE SENSOR: IF NOT OK, REPLACE THE SENSOR. IF OK, CHECK THAT THERE IS CONTINUITY ON BOTH CABLES, SUPPLY INSULATION AND GROUND INSULATION. CARRY OUT THE TESTS FROM THE SENSOR CONNECTOR TO THE SENSOR. IF NOT OK, RESTORE THE CABLE HARNESS/REPLACE THE SENSOR. IF OK, PERFORM THE TEST FROM PIN 20 AND 35 OF THE MARELLI CONTROL UNIT ENGINE CONNECTOR.

DIAGNOSTICS INSTRUMENT: LOGIC ERRORS



Engine speed sensor P0336

- signal not valid

Error cause

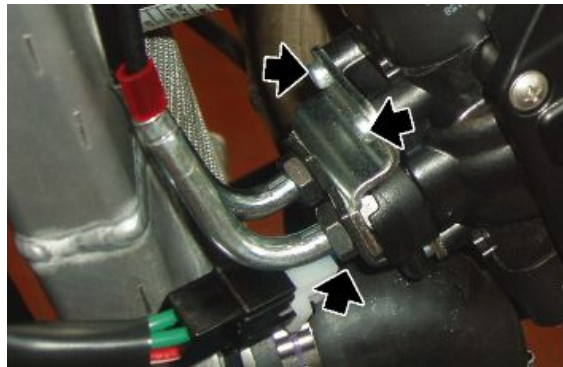
- Probable bad contact in the electric circuit detected at PIN 20 - 35 of the ENGINE connector

Troubleshooting

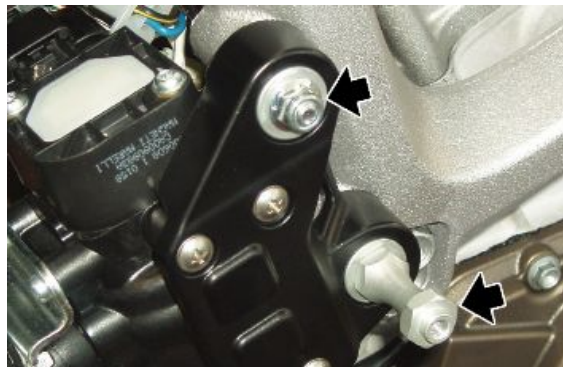
- Check the electric circuit is in good conditions and the flywheel teeth cleaning and correct positioning of the sensor in its own housing: if it is not, replace it. If it is OK, replace the sensor

Twistgrip position sensor**REMOVAL**

- Remove the left fairing.
- Loosen the two throttle cable nuts.
- Unscrew and remove the three plate fixing screws.
- Remove the throttle cables.



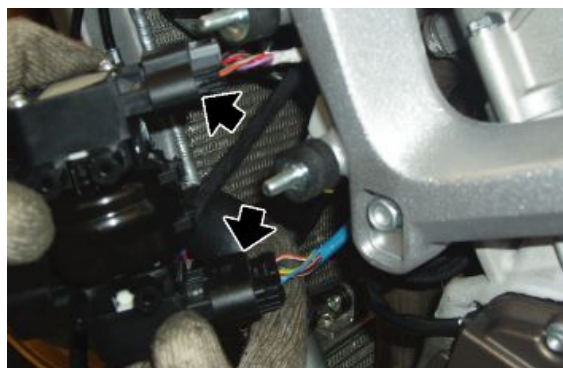
- Unscrew and remove the nut and the stud bolt.
- Retrieve the washers.



- Move the hand grip position sensor, disconnect the two connectors.
- Remove the hand grip position sensor.

NOTE

WHEN REFITTING, REMEMBER NOT TO INVERT THE CONNECTORS.
THE LIGHT BLUE CONNECTOR HAS THE BLUE CABLE AND THE WHITE CONNECTOR HAS THE WHITE CABLE.



Function

The throttle grip is the part to which the throttle control cables arrive; its task is to translate the rider's power request (Demand) into an electrical signal to be sent to the electronic control unit.

Operation / operating principle

The two throttle cables (opening and closing) actuate on a scroll mounted on a shaft and which is sent back to its home position by a return spring. On the shaft covers there are 2 double track potentiometers (4 control tracks) by means of which the torque demand is read (and checked). The 4 potentiometers are tinned and magnetically controlled (contactless); they cannot be overhauled nor replaced

Level in wiring diagram:

Hand grip position sensor

Location:

- on the vehicle: front left part, next to the cooling liquid radiator
- connector: on the sensor

Electrical specifications

- Not detected by a multimeter as they are contactless: read the voltage of the 4 tracks by the diagnosis instrument

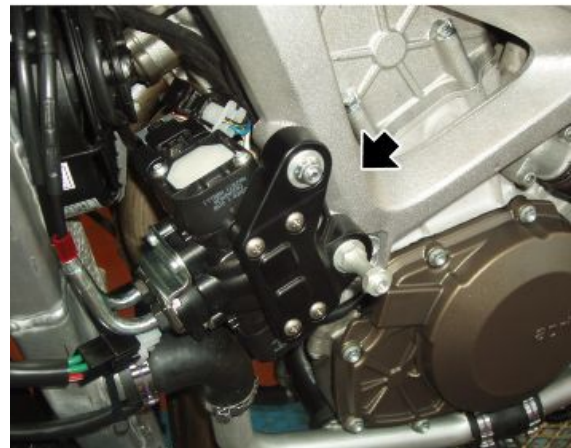
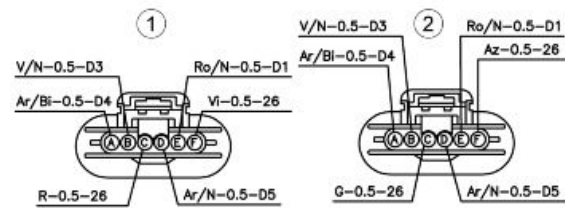
Pin out:

BLUE connector

- A: Track A supply
- B: Track A ground
- C: Track A signal
- D: Track B supply
- E: Track B ground
- F: Track B signal

WHITE connector

- A: Track C supply
- B: Track C ground



- C: Track C signal
- D: Track D supply
- E: Track D ground
- F: Track D signal

DIAGNOSIS INSTRUMENT: PARAMETERS

Blue lower connector throttle grip position sensor - track A

- Example value with key ON: 1107 mV
- Example value with engine on: -

Voltage value of the lower potentiometer - track A

Blue lower connector throttle grip position sensor - track B

- Example value with key ON: 1070 mV
- Example value with engine on: -

Voltage value times 2 of the lower potentiometer track B

White upper connector throttle grip position sensor - track C

- Example value with key ON: 3560 mV
- Example value with engine on: -

Voltage value of the upper potentiometer track C

White upper connector throttle grip position sensor - track D

- Example value with key ON: 3555 mV
- Example value with engine on: -

Voltage value times 2 of the upper potentiometer track D

Throttle grip position sensor

- Example value with key ON: 1107 mV
- Example value with engine on: -

Voltage corresponding to the potentiometer track A

Throttle grip opening percentage

- Example value with key ON: 0 mV
- Example value with engine on: -

With a released throttle grip, the value read should be 0%, whereas 100 % should be read with throttle grip fully twisted.

DIAGNOSIS INSTRUMENT: STATUSES

Throttle grip

- Slightly twisted_choked_fully twisted

Throttle grip self-acquisition

- carried out/not carried out

CAUTION

BEFORE CARRYING OUT ANY TROUBLESHOOTING, CAREFULLY READ THE GENERAL TROUBLESHOOTING CONCEPTS FOR ELECTRICAL DEVICES AT THE BEGINNING OF THE CHECK AND CONTROL SECTION IN THE ELECTRICAL SYSTEM CHAPTER.

DIAGNOSIS INSTRUMENT: ELECTRICAL ERRORS

Blue lower connector throttle grip position sensor - track A P0150

- short circuit to positive/ open circuit, short circuit to negative

Error cause

- If shorted to positive: excessive voltage has been detected at PIN 39 of the VEHICLE connector. If the circuit is open, shorted to negative: voltage equal to zero has been detected at PIN 39 of the VEHICLE connector

Troubleshooting

- shorted to positive: check the value shown by the parameter of the BLUE lower connector Throttle Grip Position Sensor - track A: disconnect the connector and read the value indicated by the diagnosis instrument: if the voltage does not vary, there is a short circuit in the cable wiring; replace the throttle grip sensor if the voltage drops to zero.
- if the circuit is open, shorted to negative: check the throttle grip sensor connector and the Marelli control unit connector. If not OK, restore. If OK, check circuit continuity between the two cable terminals. If not OK, restore; if OK, check the cable ground insulation (from the throttle grip sensor connector or the control unit connector): if the cable is not ground insulated, restore the wiring. If it is ground insulated, and with the key set to ON, check that there is power supply for the potentiometer PIN A and that PIN C is connected to ground. If both are correct, replace the throttle grip sensor; if not, check the continuity of the cable that is not functioning properly: if there is continuity, replace the control unit; if not, restore the wiring

Blue lower connector throttle grip position sensor - track B P0151

- short circuit to positive/ open circuit, short circuit to negative

Error cause

- If shorted to positive: excessive voltage has been detected at PIN 13 of the VEHICLE connector. If the circuit is open, shorted to negative: voltage equal to zero has been detected at PIN 13 of the VEHICLE connector

Troubleshooting

- short circuit to positive: check the value shown by the parameter of the BLUE lower connector Throttle Grip position Sensor track B: disconnect the connector and read the value indicated by the diagnosis instrument: if the voltage does not vary, there is a short circuit in the cable wiring; replace the throttle grip sensor if the voltage drops to zero.
- if the circuit is open, shorted to negative: check the throttle grip sensor connector and the Marelli control unit connector. If not OK, restore. If OK, check circuit continuity between the two cable terminals. If not OK, restore; if OK, check the cable ground insulation (from the

throttle grip sensor connector or the control unit connector): if the cable is not ground insulated, restore the wiring. If it is ground insulated, and with the switch key set to ON, check that there is power supply for the potentiometer PIN D and that PIN F is connected to ground. If both are correct, replace the throttle grip sensor; if not, check the continuity of the cable that is not functioning properly: if there is continuity, replace the control unit; if not, restore the wiring

DIAGNOSIS INSTRUMENT: ELECTRICAL ERRORS

White upper connector throttle grip position sensor - track C P0152

- short circuit to positive/ open circuit, short circuit to negative

Error cause

- If shorted to positive: excessive voltage has been detected at PIN 23 of the ENGINE connector. If the circuit is open, shorted to negative: voltage equal to zero has been detected at PIN 23 of the ENGINE connector

Troubleshooting

- shorted to positive: check the value shown by the parameter of the white upper connector Throttle Grip Position Sensor - track C: disconnect the connector and read the value indicated by the diagnosis instrument: if the voltage does not vary, there is a short circuit in the cable wiring; replace the throttle grip sensor if the voltage drops to zero.
- if the circuit is open, shorted to negative: carry out the open circuit, shorted to negative: check the throttle grip sensor connector and the Marelli control unit connector. If not OK, restore. If OK, check circuit continuity between the two cable terminals. If not OK, restore; if OK, check the cable ground insulation (from the throttle grip sensor connector or the control unit connector): if the cable is not ground insulated, restore the wiring. If it is ground insulated, and with the key set to ON, check that there is power supply for the potentiometer PIN A and that PIN C is connected to ground. If both are correct, replace the throttle grip sensor; if not, check the continuity of the cable that is not functioning properly: if there is continuity, replace the control unit; if not, restore the wiring

White upper connector throttle grip position sensor - track D P0153

- short circuit to positive/ open circuit, short circuit to negative

Error cause

- If shorted to positive: excessive voltage has been detected at PIN 11 of the ENGINE connector. If the circuit is open, shorted to negative: voltage equal to zero has been detected at PIN 11 of the ENGINE connector

Troubleshooting

- shorted to positive: check the value shown by the parameter of the white upper connector Throttle Grip Position Sensor - track D: disconnect the connector and read the value indi-

cated by the diagnosis instrument: if the voltage does not vary, there is a short circuit in the cable wiring; replace the throttle grip sensor if the voltage drops to zero.

- if the circuit is open, shorted to negative: check the throttle grip sensor connector and the Marelli control unit connector. If not OK, restore. If OK, check circuit continuity between the two cable terminals. If not OK, restore; if OK, check the cable ground insulation (from the throttle grip sensor connector or the control unit connector): if the cable is not ground insulated, restore the wiring. If it is ground insulated, and with the switch key set to ON, check that there is power supply for the potentiometer PIN D and that PIN F is connected to ground. If both are correct, replace the throttle grip sensor; if not, check the continuity of the cable that is not functioning properly: if there is continuity, replace the control unit; if not, restore the wiring

DIAGNOSIS INSTRUMENT: LOGIC ERRORS

Blue lower connector throttle grip position (tracks A-B) P0154

- incongruent signal

Error cause

- Two illogical voltage signals have been detected at PIN 13 and 39 of the ENGINE connector (tracks A-B)

Troubleshooting

- Check the parameters of the blue lower connector Throttle Grip Position Sensor - tracks A and B: if one of the two values clearly deviates from 600-1400 mV, it means that this potentiometer is defective. Check the throttle grip sensor connector and the control unit connector: if not OK, restore. If OK, check that cable resistance between the throttle grip sensor connector and the control unit is a few tenths of Ohm: if this is not the case, restore wiring. If the value is correct, replace the complete throttle grip sensor

White upper connector throttle grip position (tracks C-D) P0155

- incongruent signal

Error cause

- Two illogical voltage signals have been detected at PIN 23 and 11 of the ENGINE connector (tracks A-B)

Troubleshooting

- Check the parameters of the white upper connector Throttle Grip Position Sensor - tracks C and D: if one of the two values clearly deviates from 600-1400 mV, it means that this potentiometer is defective. Check the throttle grip sensor connector and the control unit connector: if not OK, restore. If OK, check that cable resistance between the throttle grip sensor connector and the control unit is a few tenths of Ohm: if this is not the case, restore wiring. If the value is correct, replace the complete throttle grip sensor

Throttle grip position P0156

- incongruent signal

Error cause

- The value of the lower side sensor (tracks A-B) does not coincide with the value of the upper side sensor (tracks C-D)

Troubleshooting

- Replace the throttle grip sensor

DIAGNOSIS INSTRUMENT: ADJUSTABLE PARAMETERS

Throttle grip self-acquisition: -

RESET PROCEDURE

- If Marelli control unit or its mapping are replaced or if you carry out control unit EEPROM zero setting or if you replace the throttle grip sensor, it is necessary to carry out the handle grip self-acquisition procedure with the diagnosis instrument: once the check is completed, make sure that the throttle grip Self-acquisition status indicates: carried out

CAUTION

THE TWO CONNECTORS WHICH GET TO THE THROTTLE GRIP SENSOR ARE ALIKE BUT THEY SHOULD NEVER BE INVERTED. MARK OR CHECK THE CONNECTOR MARKING BEFORE REMOVING THEM (BLUE STAMP + BLUE BAND). THE BLUE CONNECTOR AND COLLAR ARE PLACED DOWNWARDS AND THE WHITE CONNECTOR AND COLLAR ARE PLACED UPWARDS.

Intake pressure sensor

Function

The pressure sensors (one per bank), are fundamental for calculation of generated torque, for calculation of ambient pressure and for correct ignition timing during start-up.

Operation / operating principle

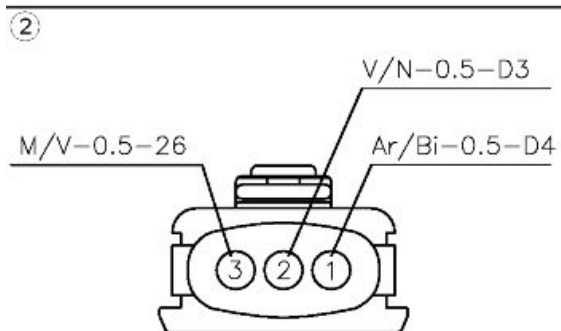
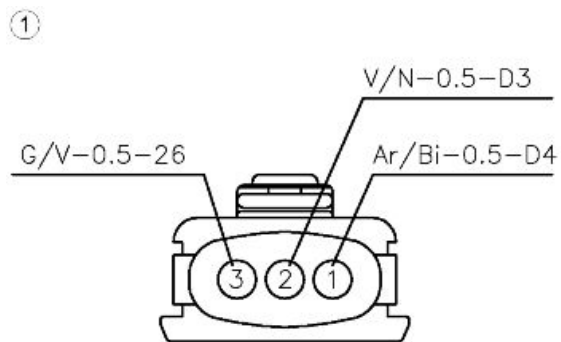
Diaphragm sensor which translates the diaphragm position into electrical voltage when in contact with the intake air.

Level in wiring diagram:

Intake air temperature sensor

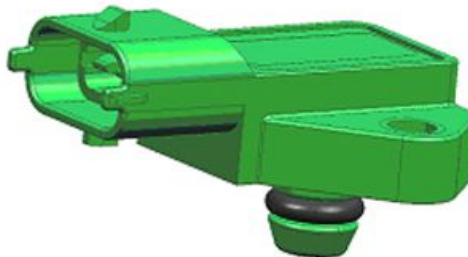
Location:

- on the vehicle: sensor for rear cylinders (1 and 3) on the right of the filter box, sensor for front cylinders (2 and 4) on the left of the filter box.
- connector: on the sensor.



Electrical specifications: -**Pin out:**

1. Power supply 5V
2. Ground connection
3. Output signal

**DIAGNOSIS INSTRUMENT: PARAMETERS**

Front Cylinder Intake Pressure (2 and 4)

- Example value with key ON: 1003 mbar
- Example value with engine on: 720 mbar
- NOTE: pressure read by the front sensor

Rear Cylinder Intake Pressure (1 and 3)

- Example value with key ON: 1004 mbar
- Example value with engine on: 715 mbar
- NOTE: pressure read by the rear sensor

Front Cylinder estimated Intake Pressure (2 and 4)

- Example value with key ON: 1003 mbar
- Example value with engine on: 721 mbar
- NOTE: pressure estimated by the control unit according to the throttle position

Rear Cylinder estimated Intake Pressure (1 and 3)

- Example value with key ON: 1004 mbar
- Example value with engine on: 735 mbar
- NOTE: pressure estimated by the control unit according to the throttle position

CAUTION

BEFORE CARRYING OUT ANY TROUBLESHOOTING, CAREFULLY READ THE GENERAL TROUBLESHOOTING CONCEPTS FOR ELECTRICAL DEVICES AT THE BEGINNING OF THE CHECK AND CONTROL SECTION IN THE ELECTRICAL SYSTEM CHAPTER.

DIAGNOSIS INSTRUMENT: ELECTRICAL ERRORS

rear cylinder air pressure sensor P0105

- shorted to positive / open circuit, shorted to negative.

Error cause

- If shorted to positive: excessive voltage has been detected at PIN 24. If the circuit is open, shorted to negative: voltage equal to zero has been detected at PIN 24.

Troubleshooting

- If shorted to positive: see that the parameter of the rear cylinders air Pressure Sensor on the diagnosis instrument reads approx. 1200 mbar; disconnect the sensor connector: if the value does not vary, it means that the cable is shorted between the control unit connector and the sensor connector: restore the cable harness; Replace the sensor if the value varies.
- If the circuit is open, shorted to negative: check the Marelli control unit connector and the sensor connector; if not OK, restore. If everything is OK, with key set to OFF, check if there is continuity between the PIN 24 of the Marelli control unit and the sensor connector PIN 3: if there is no continuity, restore the cable harness. If there is continuity, check the cable ground insulation: if there is continuity to ground, restore the cable harness; if not, with key set to ON check that the voltage on sensor connector PIN 1 is approx. 5 V: if not OK, set the key to OFF and check continuity between the ENGINE connector PIN 25 and the sensor connector PIN 1: if not OK, restore the cable harness; if OK, replace the control unit; if there is 5V voltage at PIN 1, and with key set to ON, check the continuity to ground of the sensor connector PIN 3: if not OK, restore the cable harness; if OK, replace the sensor.

front cylinder air pressure sensor P0106

- shorted to positive / open circuit, shorted to negative.

Error cause

- If shorted to positive: excessive voltage has been detected at PIN 49. If the circuit is open, shorted to negative: voltage equal to zero has been detected at PIN 49.

Troubleshooting

- If shorted to positive: see that the parameter of the front cylinders air Pressure Sensor on the diagnosis instrument reads approx. 1200 mbar; disconnect the sensor connector: if the value does not vary, it means that the cable is shorted between the control unit connector and the sensor connector: restore the cable harness; Replace the sensor if the value varies.
- If the circuit is open, shorted to negative: check the Marelli control unit connector and the sensor connector; if not OK, restore. If everything is OK, with key set to OFF, check if there is continuity between the PIN 49 of the Marelli control unit and the sensor connector PIN 3: if there is no continuity, restore the cable harness. If there is continuity, check the cable ground insulation: if there is continuity to ground, restore the cable harness; if not, with key set to ON check that the voltage on sensor connector PIN 1 is approx. 5 V: if not OK, set the key to OFF and check continuity between the ENGINE connector PIN 25 and the sensor connector PIN 1: if not OK, restore the cable harness; if OK, replace the control unit; if there is 5V voltage at PIN 1, and with key set to ON, check the continuity to ground of the sensor connector PIN 3: if not OK, restore the cable harness; if OK, replace the sensor.

DIAGNOSIS INSTRUMENT: LOGIC ERRORS

rear cylinder air pressure sensor P0107

- signal not valid.

Error cause

- According to the engine operation data (rpm, throttle, etc.) an average value for the intake pressure is estimated: if the value read deviates by a given percentage, this error is activated. The most frequent causes can be: abnormal resistance in the sensor circuit (for example, rusted terminals) or sensor with poor performance.

Troubleshooting

- Check the Marelli control unit connector and the sensor connector; if not OK, restore. If everything is OK, check that resistance between VEHICLE connector PIN 24 and sensor connector PIN 3 is a few tenths of an Ohm; If it is above that value, restore cable harness. Replace the sensor if it is correct.

rear cylinder air pressure sensor P0108

- signal not valid.

Error cause

- According to the engine operation data (rpm, throttle, etc.) an average value for the intake pressure is estimated: if the value read deviates by a given percentage, this error is activated. The most frequent causes can be: abnormal resistance in the sensor circuit (for example, rusted terminals) or sensor with poor performance.

Troubleshooting

- Check the filter box large connector, the Marelli control unit connector and the sensor connector; if not OK, restore. If everything is OK, check that resistance between VEHICLE connector PIN 49 and sensor connector PIN 3 is a few tenths of an Ohm; If it is above that value, restore cable harness. Replace the sensor if it is correct.

Error for unexpected air intake in the rear cylinder manifold P0210

- signal not valid.

Error cause

- A small difference between the estimated pressure and the measured pressure has been detected: the measured pressure is higher than the estimated one (for example, the pipe between sensor and throttle body is squashed or there is a hole in the intake manifold).

Troubleshooting

- Check the pneumatic system between the pressure sensor and the socket to read pressure on the throttle body; check that the intake manifold is in good conditions and the pressure reading hole is clean.

Error for unexpected air intake in the front cylinder manifold P0211

- signal not valid.

Error cause

- A small difference between the estimated pressure and the measured pressure has been detected: the measured pressure is higher than the estimated one (for example, the pipe between sensor and throttle body is squashed or there is a hole in the intake manifold).

Troubleshooting

- Check the pneumatic system between the pressure sensor and the socket to read pressure on the throttle body; check that the intake manifold is in good conditions and the pressure reading hole is clean.

Estimation error for rear cylinder intake manifold pressure P0215

- too high pressure/too low pressure.

Error cause

- A substantial difference between the estimated pressure and the measured pressure has been detected (for example, the pipe between sensor and throttle body is fully detached/ clogged or squashed).

Troubleshooting

- Check the pneumatic system between the pressure sensor and the socket to read pressure on the throttle body; check that the intake manifold is in good conditions and the pressure reading hole is clean: there is an evident defect in the intake and pressure reading systems.

Estimation error for front cylinder intake manifold pressure P0216

- too high pressure/too low pressure.

Error cause

- A substantial difference between the estimated pressure and the measured pressure has been detected (for example, the pipe between sensor and throttle body is fully detached/ clogged or squashed).

Troubleshooting

- Check the pneumatic system between the pressure sensor and the socket to read pressure on the throttle body; check that the intake manifold is in good conditions and the pressure reading hole is clean: there is an evident defect in the intake and pressure reading systems.

Pressure too low at rear cylinder manifold error P0217

- signal not valid.

Error cause

- A small difference between the estimated pressure and the measured pressure has been detected: the measured pressure is below the estimated one (for example, smeared throttle body).

Troubleshooting

- Check the pneumatic system between the pressure sensor and the socket to read pressure on the throttle body; check that the intake manifold is in good conditions and the pressure reading hole is clean.

Pressure too low at front cylinder manifold error P0218

- signal not valid.

Error cause

- A small difference between the estimated pressure and the measured pressure has been detected: the measured pressure is below the estimated one (for example, smeared throttle body).

Troubleshooting

- Check the pneumatic system between the pressure sensor and the socket to read pressure on the throttle body; check that the intake manifold is in good conditions and the pressure reading hole is clean.

Engine temperature sensor

Function

It tells the engine temperature to the control unit to improve its performance and to calculate the engine friction for a better estimation of the generated torque.

Operation / operating principle

NTC type sensor (resistance sensor, inversely variable with temperature).

Level in wiring diagram:

Temperature sensors

Location:

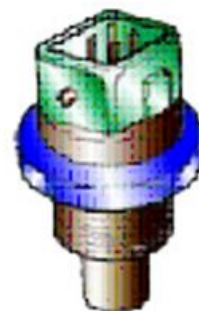
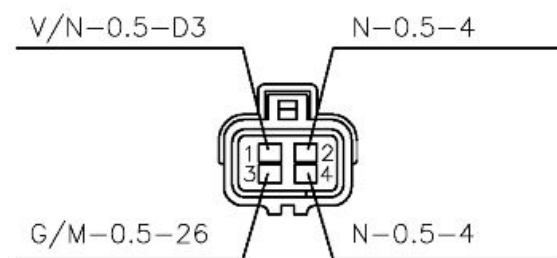
- on the vehicle: right side next to the two heads.
- connector: on the sensor.

Electrical characteristics:

- Resistance at 25°: 2.05 k Ω \pm 100 Ω
- Resistance at 60°: 575 k Ω \pm 15 Ω
- Resistance at 90°: 230 k Ω \pm 5 Ω

Pin out:

1. B1 yellow/brown : 0-5 V signal



2. B2 green/black: Ground connection

DIAGNOSIS INSTRUMENT: PARAMETERS

Engine temperature:

- Example value with key ON: 25° C
- Example value with engine on: 75° C
- In case of recovery, this value is set by the control unit: if there is a malfunction after engine start-up, temperature decreases up to approximately 75°.

Engine temperature pre Recovery:

- Example value with key ON: -40° C
- Example value with engine on: -40° C
- Value drawn from the signal read without taking into account any recovery: the value in the example refers to an open circuit.

Engine temperature at start-up:

- Example value with key ON: -40° C
- Example value with engine on: 25° C
- The temperature value is stored during engine start-up. With key ON, value -40°C is read.

CAUTION

BEFORE CARRYING OUT ANY TROUBLESHOOTING, CAREFULLY READ THE GENERAL TROUBLESHOOTING CONCEPTS FOR ELECTRICAL DEVICES AT THE BEGINNING OF THE CHECK AND CONTROL SECTION IN THE ELECTRICAL SYSTEM CHAPTER.

DIAGNOSTICS INSTRUMENT: ELECTRICAL ERRORS

engine temperature sensor P0115

- open circuit, shorted to positive / shorted to negative.

Error cause

- If the circuit is open, shorted to positive: excessive voltage has been detected at PIN 12 of the ENGINE connector. If shorted to negative: voltage equal to zero has been detected. The instrument panel does not indicate the presence of this error even in the ATT status.

Troubleshooting

- If the circuit is open, shorted to positive: check the sensor connector and the Marelli control unit connector. If they are OK, check sensor continuity: replace the sensor if not OK; if OK, check continuity between the ENGINE connector PIN 12 and the sensor PIN 1: restore cable harness if there is not continuity; if it is OK, reconnect the control unit connector and, with key set to key ON, check the continuity between the sensor connector PIN 2 and the vehicle ground connection: if OK, it means that the error cause is that the cable is shorted to positive and it is necessary to restore the cable harness between ENGINE PIN 12 and sensor PIN 1; if there is no continuity with the ground connection, check the sensor connector and the Marelli control unit connector. If not OK, restore the cable harness. If OK, check continuity

between the ENGINE connector PIN 6 or 17 and the sensor connector PIN 2: restore the cable harness if there is not continuity. If there is, it means that the control unit does not supply the ground connection and therefore should be replaced.

- If shorted to negative, check sensor correct resistance: if resistance is null, replace the sensor; if resistance is correct, it means that the Yellow/Brown cable has ground connection: restore the cable harness

DIAGNOSIS INSTRUMENT: LOGIC ERRORS

engine temperature sensor P0116

- signal not valid.

Error cause

- An excessive temperature variation has been detected: for example, the cause may be a contact resistance between the terminals. The instrument panel does not indicate the presence of this error even in the ATT status.

Troubleshooting

- Check the sensor connector and the ENGINE connector of the Marelli control unit.

NOTES

No error is detected if the sensor does not work correctly or the control unit connector or sensor terminals are rusty: then check through Navigator if the temperature indicated is the same as the engine temperature. Check also that the sensor electrical characteristics are observed: replace the sensor if not OK; if it is OK, check the sensor connector and the Marelli control unit connector.

Air temperature sensor

Function

it tells the control unit the intake air temperature in order to calculate oxygen presence so as to optimise the petrol quantity necessary for correct combustion

Operation / operating principle

NTC type sensor (resistance sensor, inversely variable with temperature)

Level in wiring diagram:

Temperature sensors

Location:

- sensor: on rear side of the filter box
- connector: on the sensor

Electrical characteristics: Resistance

- at 0 °C (32 °F): 32.5 kΩ ± 5%
- at 25 °C (77 °F): 10.0 kΩ ± 5%

Pin out:

1. 0-5 V signal
2. Ground connection

DIAGNOSIS INSTRUMENT: PARAMETERS

Air temperature

Example value with key ON: 26 °C (78.8 °F)

In case of recovery, this value is set by the control unit

Air temperature pre Recovery

Example value with key ON: -40 °C (-40.0 °F)

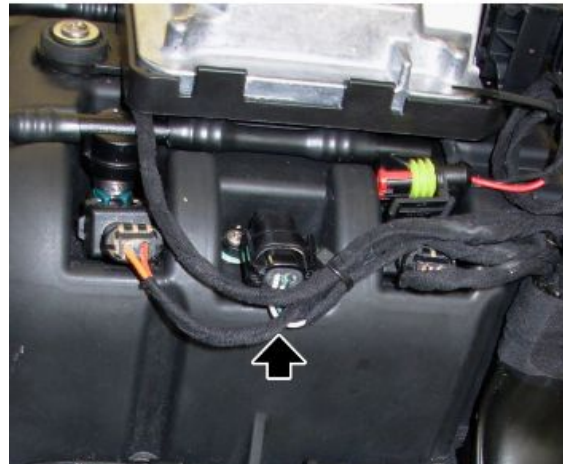
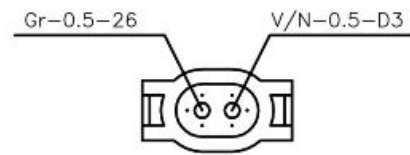
Value drawn from the signal read without taking into account any recovery: the value in the example refers to an open circuit

CAUTION

BEFORE CARRYING OUT ANY TROUBLESHOOTING, CAREFULLY READ THE GENERAL TROUBLESHOOTING CONCEPTS FOR ELECTRICAL DEVICES AT THE BEGINNING OF THE CHECK AND CONTROL SECTION IN THE ELECTRICAL SYSTEM CHAPTER.

DIAGNOSIS INSTRUMENT: ELECTRICAL ERRORS

air temperature sensor P0110



- open circuit, shorted to positive / shorted to negative

Error cause

- If the circuit is open, shorted to positive: excessive voltage has been detected at PIN 37 of the ENGINE connector. If shorted to negative: voltage equal to zero has been detected. The instrument panel does not indicate the presence of this error even in the ATT status.

Troubleshooting

- If the circuit is open, shorted to positive: check the sensor connector and the Marelli control unit connector. If they are OK, check sensor continuity: replace the sensor if not OK; if OK, check continuity between the ENGINE connector PIN 37 and the sensor PIN 1: restore cable harness if there is not continuity; if it is OK, reconnect the control unit connector and, with key set to key ON, check the continuity between the sensor connector PIN 2 and the vehicle ground connection: if OK, it means that the error cause is that the cable is shorted to positive and it is necessary to restore the cable harness between ENGINE PIN 37 and sensor PIN 1; check the sensor connector and the Marelli control unit connector. If not OK, restore the cable harness. If OK, check continuity between the ENGINE connector PIN 6 or 17 and the sensor connector PIN 2: restore the cable harness if there is not continuity. If there is, it means that the control unit does not supply the ground connection and therefore should be replaced
 - If shorted to negative, check sensor correct resistance: if resistance = 0, replace the sensor; if resistance is correct, it means that the grey cable has ground connection: restore the cable harness
-

Lambda sensor

Function

In charge of telling the control unit whether the mixture is lean or rich

Operation / Operating principle

The Marelli injection control unit reads and interprets a voltage generated by the difference in oxygen content between the exhaust fumes and the ambient. It does not require an external supply source but, in order to work properly, it should reach a high operating temperature: that is why there is a heating circuit inside

Level in electrical circuit diagram:

Oxygen sensor

Location:

- on the vehicle: left side of the vehicle
- connector: on the right of the pinion cover (4-ways black connector)

Electrical specifications

- Heater circuit: 7-9Ω at Ambient temp.

Pin out:

1. Sensor signal + (black wire)
2. Sensor signal - (grey wire)
3. Heater ground connection (white cable)
4. Heater power supply (white cable)

DIAGNOSIS INSTRUMENT: PARAMETERS

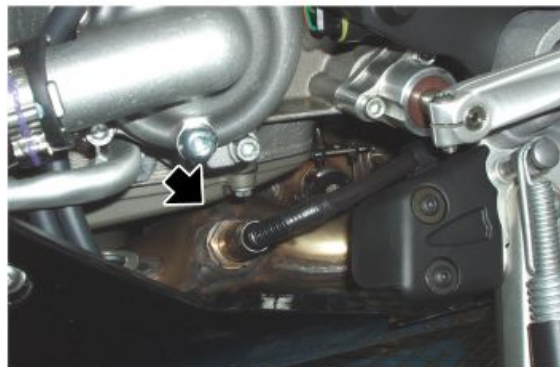
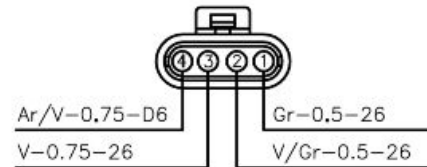
Oxygen sensor

- Example value with key ON: 0 mV
- Example value with engine on:
100--900 mV

If there is a short circuit at + 5 V or above, the oxygen sensor parameter is not equal to the value read by the control unit; a recovery value is displayed instead

Lambda correction

- Example value with key ON: 1.00 mV



- Example value with engine on: 0.90 - 1.10mV

In closed loop, the value must be close to 1.00 (values not within the 0.90 - 1.10 interval indicate a fault): for example, value 0.75 corresponds to +25% with respect to the reference injection time; 1.25 corresponds to -25%. In an open circuit, the oxygen sensor signal is too low. Therefore, the control unit takes it as a lean combustion condition and will try to enrich it. The value read will be 0.75: once this correction has been tried, the value shifts to 1.00 fixed and the Oxygen sensor error is signalled

CAUTION

BEFORE CARRYING OUT ANY TROUBLESHOOTING, CAREFULLY READ THE GENERAL TROUBLESHOOTING CONCEPTS FOR ELECTRICAL DEVICES AT THE BEGINNING OF THE CHECK AND CONTROL SECTION IN THE ELECTRICAL SYSTEM CHAPTER.

DIAGNOSIS INSTRUMENT: STATUSES

Oxygen sensor: Start-up_Lean_Rich_Fault due to rich value_Fault due to lean value

- If the probe connector is removed (voltage almost equal to zero), the status is Fault due to lean value

Lambda check: Open loop/Closed loop/Rich in closed loop/Lean in closed loop/enriched

- Closed loop indicates that the control unit is using the oxygen sensor signal to keep the combustion as close as possible to the stoichiometric value.

DIAGNOSIS INSTRUMENT: ACTIVATION

Oxygen sensor heating

- The injection relay (No. 33 in the wiring diagram, placed under the saddle next to the battery positive, CHECK, however, the identification of the relay with the colour of the cables) is energised and the heating circuit is closed to ground 5 times (pin 3 of the oxygen sensor connector). The continuity of the wiring is necessary for correct activation: no error indications are displayed in case of lack of activation

DIAGNOSIS INSTRUMENT: ELECTRICAL ERRORS

oxygen sensor P0130

- shorted to positive

Error cause

- Excessive voltage (battery voltage) has been detected at PIN 10 and 22 of the ENGINE connector. Caution: the 'Oxygen sensor' parameter is not the real value that is read; a re-

covery value is displayed instead. The instrument panel does not indicate the presence of this error even in the ATT status.

Troubleshooting

- shorted to positive: with key set to ON, disconnect the sensor connector and measure PIN 1 voltage on the cable harness side (grey cable): if there is voltage (5 or 12 V), restore the cable harness; if there is not, replace the oxygen sensor

Lambda probe heating P0135

- short circuit to positive/ open circuit, short circuit to negative

Error cause

- If shorted to positive: excessive voltage has been detected at PIN 32 of the ENGINE connector. If the circuit is open, shorted to negative: voltage equal to zero has been detected at PIN 32 of the ENGINE connector. The instrument panel does not indicate the presence of this error even in the ATT status.

Troubleshooting

- If shorted to positive: disconnect the probe connector and check the sensor correct resistance: replace the sensor if not OK; if it is OK, restore the cable harness (green cable)
- If circuit is open, shorted to negative: check circuit continuity from probe connector (PIN 3 and 4) toward the probe: if it is not OK, replace the probe; if it is OK, check the sensor connector and the Marelli control unit connector: if it is not OK, restore; if it is OK, with key set to ON and sensor connector disconnected, check if there is battery voltage at PIN 4: if it is not OK, check the orange/green cable continuity between the probe connector and the injection relay (No. 33 in the wiring diagram, placed under the saddle next to the battery positive, CHECK, however, the identification of the relay (with the colour of the cables). If there are also coil, lower and upper injector and secondary air errors, check the relay and its excitation and power line; if there is voltage at PIN 4, check ground insulation of the green cable (PIN 3): if not OK, restore the cable harness. If it is OK, check the continuity of the Green cable (between the sensor connector PIN 3 and the ENGINE PIN 32) and restore the cable harness.
- If circuit is open, shorted to negative: check circuit continuity from probe connector (PIN 3 and 4) toward the probe: if it is not OK, replace the probe; if it is OK, check the sensor connector and the Marelli control unit connector: if it is not OK, restore; if it is OK, with key set to ON and sensor connector disconnected, check if there is battery voltage at PIN 4: if it is not OK, check the orange/green cable continuity between the probe connector and the injection relay (No. 33 in the wiring diagram, placed under the saddle next to the battery positive, CHECK, however, the identification of the relay (with the colour of the cables). If there are also coil, lower and upper injector and secondary air errors, check the relay and its excitation and power line; if there is voltage at PIN 4, check ground insulation of the green

cable (PIN 3): if not OK, restore the cable harness. If it is OK, check the continuity of the green cable (between the sensor connector PIN 3 and the ENGINE PIN 32) and restore the cable harness.

WARNING

The control unit does not detect the following malfunctions of the lambda probe circuit according to the signal: interrupted circuit, shorted to ground or sensor malfunction (for example non variable voltage). In case of fault indication, carry out the following troubleshooting.

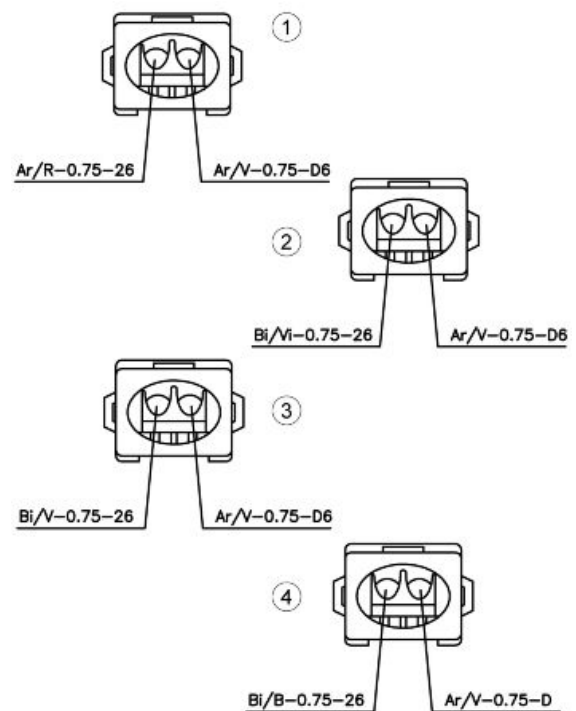
Troubleshooting

- Check circuit continuity from probe connector (PIN 1 and PIN 2) toward the probe: replace the lambda probe if there is no continuity; if there is continuity, check the sensor connector and the Marelli control unit connector: If not OK, restore. If OK, check continuity between the ENGINE connector PIN 22 and PIN 10 and restore the cable harness.

Injector

Lower injectors key:

- 1. Lower injector 1
- 2. Lower injector 3
- 3. Lower injector 2
- 4. Lower injector 4



LOWER INJECTOR

Function

To supply the correct amount of petrol at the right timing. The lower injectors work in the field of low engine revs, the upper injectors in the field of high engine revs.

Operation / Operating principle

Injector coil is excited for the petrol passage to open

Level in electrical circuit diagram:

Coils and injectors

Location:

- on the vehicle: on the throttle body
- connector: on injectors

Electrical characteristics:

14.8Ω ± 5% (at ambient temp)

Pin out:

- "+": supply
- " ": ground

DIAGNOSIS INSTRUMENT: PARAMETERS

Cylinder injection time 1

- Example value with engine on: 1.9 ms

Cylinder injection time 2

- Example value with engine on: 1.9 ms

Cylinder injection time 3

- Example value with engine on: 1.9 ms

Cylinder injection time 4

- Example value with engine on: 1.9 ms

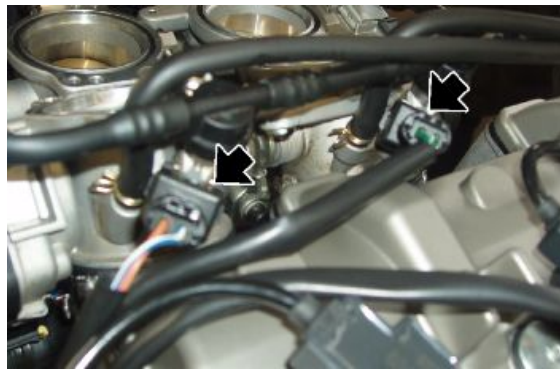
CAUTION

BEFORE CARRYING OUT ANY TROUBLESHOOTING, CAREFULLY READ THE GENERAL TROUBLESHOOTING CONCEPTS FOR ELECTRICAL DEVICES AT THE BEGINNING OF THE CHECK AND CONTROL SECTION IN THE ELECTRICAL SYSTEM CHAPTER.

DIAGNOSIS INSTRUMENT: ACTIVATION

Lower injector cylinder 1

- The injection relay (No. 33 in the wiring diagram, placed under saddle, right side; CHECK, however, the identification of the relay with the colour of the cables) is energised for 5 sec-



onds and the injector cable connected to control unit is closed to ground for 4 ms per second. Disconnect the 4-way connector of the fuel pump to be able to hear the relay and injector activation. The continuity of the wiring is necessary for correct activation: no error indications are displayed in case of lack of activation

Lower injector cylinder 2

- The injection relay (No. 33 in the wiring diagram, placed under saddle, right side; CHECK, however, the identification of the relay with the colour of the cables) is energised for 5 seconds and the injector cable connected to control unit is closed to ground for 4 ms per second. Disconnect the 4-way connector of the fuel pump to be able to hear the relay and injector activation. The continuity of the wiring is necessary for correct activation: no error indications are displayed in case of lack of activation

Lower injector cylinder 3

- The injection relay (No. 33 in the wiring diagram, placed under saddle, right side; CHECK, however, the identification of the relay with the colour of the cables) is energised for 5 seconds and the injector cable connected to control unit is closed to ground for 4 ms per second. Disconnect the 4-way connector of the fuel pump to be able to hear the relay and injector activation. The continuity of the wiring is necessary for correct activation: no error indications are displayed in case of lack of activation

Lower injector cylinder 4

- The injection relay (No. 33 in the wiring diagram, placed under saddle, right side; CHECK, however, the identification of the relay with the colour of the cables) is energised for 5 seconds and the injector cable connected to control unit is closed to ground for 4 ms per second. Disconnect the 4-way connector of the fuel pump to be able to hear the relay and injector activation. The continuity of the wiring is necessary for correct activation: no error indications are displayed in case of lack of activation

DIAGNOSIS INSTRUMENT: ELECTRICAL ERRORS

Lower injector cylinder 1 P0201

- short circuit to positive/ short circuit to negative / open circuit

Error cause

- If shorted to positive: excessive voltage has been detected at PIN 8. If shorted to negative: no voltage has been detected. If the circuit is open: an interruption has been detected

Troubleshooting

- If shorted to positive: disconnect the injector connector, set key to ON, activate the component with the diagnosis instrument and check the voltage on the orange/red cable on the injector connector (if there is voltage): if there is voltage, restore the filter box cable harness. If there is no voltage, replace the sensor

- If shorted to negative: disconnect the injector connector, set the key to ON and check if there is a ground connection on the orange/red cable: if there connection, restore the cable harness. If there is no connection, replace the injector.
- If the circuit is open: check the component correct electrical characteristic: if it is not the correct one, replace the component; if it is correct, check the connector on the component and the Marelli control unit connector: if not OK, restore. If OK, check cable continuity between the ENGINE PIN 8 and component PIN - and restore the cable harness

Lower injector cylinder 2 P0202

- short circuit to positive/ short circuit to negative / open circuit

Error cause

- If shorted to positive: excessive voltage has been detected at PIN 46. If shorted to negative: no voltage has been detected. If the circuit is open: an interruption has been detected

Troubleshooting

- If shorted to positive: disconnect the injector connector, set key to ON, activate the component with the diagnosis instrument and check the voltage on the white/green cable on the injector connector: if there is voltage, restore the filter box cable harness. If there is no voltage, replace the sensor
- If shorted to negative: disconnect the injector connector, set the key to ON and check if there is a ground connection on the white/green cable: if there connection, restore the cable harness. If there is no connection, replace the injector.
- If the circuit is open: check the component correct electrical characteristic: if it is not the correct one, replace the component; if it is correct, check the connector on the component and the Marelli control unit connector: if not OK, restore. If OK, check cable continuity between the ENGINE PIN 46 and component PIN - and restore the cable harness

Lower injector cylinder 3 P0203

- short circuit to positive/ short circuit to negative / open circuit

Error cause

- If shorted to positive: excessive voltage has been detected at PIN 34. If shorted to negative: no voltage has been detected. If the circuit is open: an interruption has been detected

Troubleshooting

- If shorted to positive: disconnect the injector connector, set key to ON, activate the component with the diagnosis instrument and check the voltage on the white/purple cable on the injector connector (if there is voltage): if there is voltage, restore the filter box cable harness. If there is no voltage, replace the sensor

- If shorted to negative: disconnect the injector connector, set the key to ON and check if there is a ground connection on the white/purple cable: if there connection, restore the cable harness. If there is no connection, replace the injector.
- If the circuit is open: check the component correct electrical characteristic: if it is not the correct one, replace the component; if it is correct, check the connector on the component and the Marelli control unit connector: if not OK, restore. If OK, check cable continuity between the ENGINE PIN 34 and component PIN - and restore the cable harness

Lower injector cylinder 4 P0204

- short circuit to positive/ short circuit to negative / open circuit

Error cause

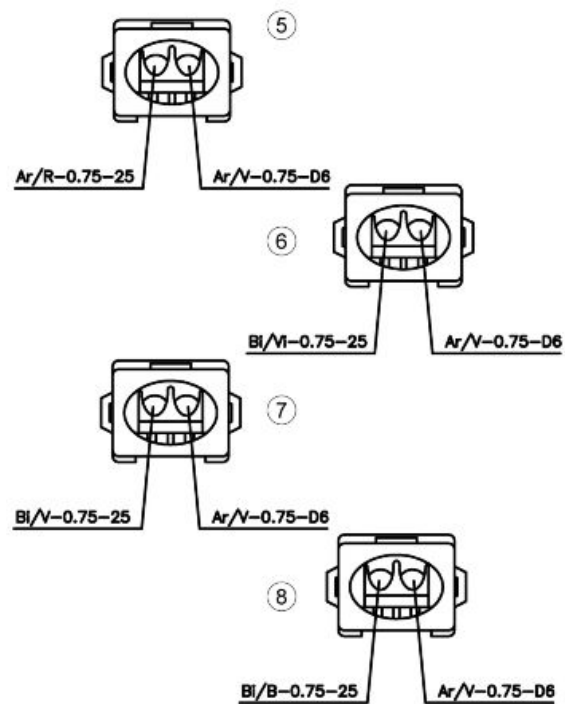
- If shorted to positive: excessive voltage has been detected at PIN 45. If shorted to negative: no voltage has been detected. If the circuit is open: an interruption has been detected

Troubleshooting

- If shorted to positive: disconnect the injector connector, set key to ON, activate the component with the diagnosis instrument and check the voltage on the white/blue cable on the injector connector (if there is voltage): if there is voltage, restore the filter box cable harness. If there is no voltage, replace the sensor
- If shorted to negative: disconnect the injector connector, set the key to ON and check if there is a ground connection on the white/blue cable: if there connection, restore the cable harness. If there is no connection, replace the injector.
- If the circuit is open: check the component correct electrical characteristic: if it is not the correct one, replace the component; if it is correct, check the connector on the component and the Marelli control unit connector: if not OK, restore. If OK, check cable continuity between the ENGINE PIN 45 and component PIN - and restore the cable harness

Upper injectors key:

- 5. Upper injector 1
- 6. Upper injector 3
- 7. Upper injector 2
- 8. Upper injector 4

**UPPER INJECTOR Function**

To supply the correct amount of petrol at the right timing. The lower injectors work in the field of low engine revs, the upper injectors in the field of high engine revs.

Operation / Operating principle

Injector coil is excited for the petrol passage to open

Level in electrical circuit diagram:

Coils and injectors

Location:

- on the vehicle: on filter box cover
- connector: on injectors

Electrical characteristics:

14.8Ω ± 5% (at ambient temp)

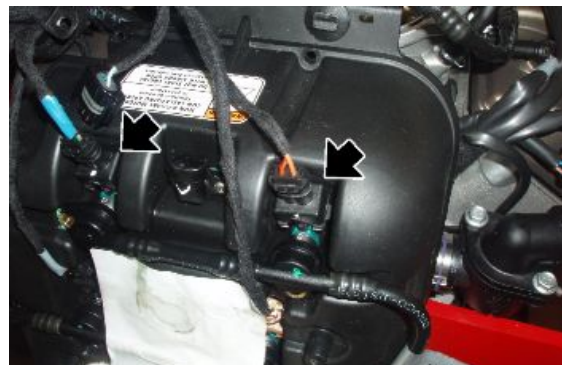
Pin out:

- "+": supply
- " ": ground

DIAGNOSIS INSTRUMENT: PARAMETERS

Cylinder injection time 1

- Example value with engine on: 1.9 ms



Cylinder injection time 2

- Example value with engine on: 1.9 ms

Cylinder injection time 3

- Example value with engine on: 1.9 ms

Cylinder injection time 4

- Example value with engine on: 1.9 ms

CAUTION

BEFORE CARRYING OUT ANY TROUBLESHOOTING, CAREFULLY READ THE GENERAL TROUBLESHOOTING CONCEPTS FOR ELECTRICAL DEVICES AT THE BEGINNING OF THE CHECK AND CONTROL SECTION IN THE ELECTRICAL SYSTEM CHAPTER.

DIAGNOSIS INSTRUMENT: ACTIVATION

Lower injector cylinder 1

- The injection relay (No. 33 in the wiring diagram, placed under saddle, right side; CHECK, however, the identification of the relay with the colour of the cables) is energised for 5 seconds and the injector cable connected to control unit is closed to ground for 4 ms per second. Disconnect the 4-way connector of the fuel pump to be able to hear the relay and injector activation. The continuity of the wiring is necessary for correct activation: no error indications are displayed in case of lack of activation

Upper injector cylinder 2

- The injection relay (No. 33 in the wiring diagram, placed under saddle, right side; CHECK, however, the identification of the relay with the colour of the cables) is energised for 5 seconds and the injector cable connected to control unit is closed to ground for 4 ms per second. Disconnect the 4-way connector of the fuel pump to be able to hear the relay and injector activation. The continuity of the wiring is necessary for correct activation: no error indications are displayed in case of lack of activation

Upper injector cylinder 3

- The injection relay (No. 33 in the wiring diagram, placed under saddle, right side; CHECK, however, the identification of the relay with the colour of the cables) is energised for 5 seconds and the injector cable connected to control unit is closed to ground for 4 ms per second. Disconnect the 4-way connector of the fuel pump to be able to hear the relay and injector activation. The continuity of the wiring is necessary for correct activation: no error indications are displayed in case of lack of activation

Upper injector cylinder 4

- The injection relay (No. 33 in the wiring diagram, placed under saddle, right side; CHECK, however, the identification of the relay with the colour of the cables) is energised for 5 seconds and the injector cable connected to control unit is closed to ground for 4 ms per second. Disconnect the 4-way connector of the fuel pump to be able to hear the relay and injector

activation. The continuity of the wiring is necessary for correct activation: no error indications are displayed in case of lack of activation

DIAGNOSIS INSTRUMENT: ELECTRICAL ERRORS

Upper injector cylinder 1 P0205

- short circuit to positive/ short circuit to negative / open circuit

Error cause

- If shorted to positive: excessive voltage has been detected at PIN 53. If shorted to negative: no voltage has been detected. If the circuit is open: an interruption has been detected

Troubleshooting

- If shorted to positive: disconnect the injector connector, set key to ON, activate the component with the diagnosis instrument and check the voltage on the orange/red cable on the injector connector (if there is voltage): if there is voltage, restore the filter box cable harness. If there is no voltage, replace the sensor
- If shorted to negative: disconnect the injector connector, set the key to ON and check if there is a ground connection on the orange/red cable: if there connection, restore the cable harness. If there is no connection, replace the injector.
- If the circuit is open: check the component correct electrical characteristic: if it is not the correct one, replace the component; if it is correct, check the connector on the component and the Marelli control unit connector: if not OK, restore. If OK, check cable continuity between PIN 53 and component PIN - and restore the cable harness

Upper injector cylinder 2 P0206

- short circuit to positive/ short circuit to negative / open circuit

Error cause

- If shorted to positive: excessive voltage has been detected at PIN 67. If shorted to negative: no voltage has been detected. If the circuit is open: an interruption has been detected

Troubleshooting

- If shorted to positive: disconnect the injector connector, set key to ON, activate the component with the diagnosis instrument and check the voltage on the white/green cable on the injector connector: if there is voltage, restore the filter box cable harness. If there is no voltage, replace the sensor
- If shorted to negative: disconnect the injector connector, set the key to ON and check if there is a ground connection on the white/green cable: if there connection, restore the cable harness. If there is no connection, replace the injector.
- If the circuit is open: check the component correct electrical characteristic: if it is not the correct one, replace the component; if it is correct, check the connector on the component

and the Marelli control unit connector: if not OK, restore. If OK, check cable continuity between PIN 67 and component PIN - and restore the cable harness

Upper injector cylinder 3 P0207

- short circuit to positive/ short circuit to negative / open circuit

Error cause

- If shorted to positive: excessive voltage has been detected at PIN 74. If shorted to negative: no voltage has been detected. If the circuit is open: an interruption has been detected

Troubleshooting

- If shorted to positive: disconnect the injector connector, set key to ON, activate the component with the diagnosis instrument and check the voltage on the white/purple cable on the injector connector (if there is voltage): if there is voltage, restore the filter box cable harness. If there is no voltage, replace the sensor
- If shorted to negative: disconnect the injector connector, set the key to ON and check if there is a ground connection on the white/purple cable: if there connection, restore the cable harness. If there is no connection, replace the injector.
- If the circuit is open: check the component correct electrical characteristic: if it is not the correct one, replace the component; if it is correct, check the connector on the component and the Marelli control unit connector: if not OK, restore. If OK, check cable continuity between PIN 74 and component PIN - and restore the cable harness

Upper injector cylinder 4 P0208

- short circuit to positive/ short circuit to negative / open circuit

Error cause

- If shorted to positive: excessive voltage has been detected at PIN 68. If shorted to negative: no voltage has been detected. If the circuit is open: an interruption has been detected

Troubleshooting

- If shorted to positive: disconnect the injector connector, set key to ON, activate the component with the diagnosis instrument and check the voltage on the white/blue cable on the injector connector (if there is voltage): if there is voltage, restore the filter box cable harness. If there is no voltage, replace the sensor
- If shorted to negative: disconnect the injector connector, set the key to ON and check if there is a ground connection on the white/blue cable: if there connection, restore the cable harness. If there is no connection, replace the injector.
- If the circuit is open: check the component correct electrical characteristic: if it is not the correct one, replace the component; if it is correct, check the connector on the component and the Marelli control unit connector: if not OK, restore. If OK, check cable continuity between PIN 68 and component PIN - and restore the cable harness

Fuel pump

Function

Fuel pump: keeps pressure of the injectors supply duct.

Low fuel: tells to the instrument panel about low fuel

Operation / Operating principle

Low fuel: it is a resistance that if correctly supplied varies its electrical resistance if it is damped or not by petrol.

Level in electrical circuit diagram:

Injection load relay

Location:

- on the vehicle: on the tank.
- connector: on right rear frame (4-ways black).

Electrical characteristics:

PIN 1-2: 0.5 - 1 ohm; PIN 3-4: you do not need to measure the component electrical resistance since it works correctly with suitable supply from the instrument panel only. Check correct operation as follows: connect in series a bulb of approximately 2 W: it should turn on if the tank is in reserve, otherwise, it remains off.

Pin out:

1. + 12 V
2. ground connection
3. ground connection
4. + 12 V (signal)

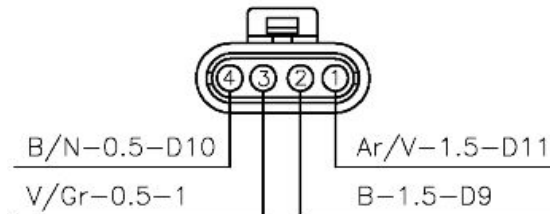
CAUTION

BEFORE CARRYING OUT ANY TROUBLESHOOTING, CAREFULLY READ THE GENERAL TROUBLESHOOTING CONCEPTS FOR ELECTRICAL DEVICES AT THE BEGINNING OF THE CHECK AND CONTROL SECTION IN THE ELECTRICAL SYSTEM CHAPTER.

DIAGNOSIS INSTRUMENT: ACTIVATION

Fuel pump

NOTE: The injection relay (No 33 in the wiring diagram, position under the saddle, next to the battery positive, CHECK, however, the identification of the relay with the colour of the cables) is energised for



30 seconds. The continuity of the wiring is necessary for correct activation: no error indications are displayed in case of lack of activation

DIAGNOSIS INSTRUMENT: ELECTRICAL ERRORS

fuel pump relay control P0230

- shorted to positive / open circuit, shorted to negative.

Error cause

- If shorted to positive: excessive voltage has been detected at PIN 73 of the VEHICLE connector. If the circuit is open, shorted to negative: voltage equal to zero has been detected at PIN 73 of the VEHICLE connector.

Troubleshooting

- If shorted to positive: check whether the relay electrical specifications are correct by disconnecting it from the cable harness. If are not OK, replace the relay; if OK, restore the cable harness (Brown/Black cable).
- If the circuit is open, shorted to negative: check the relay electrical characteristics are correct by disconnecting it from the cable harness; if it is not OK, replace the relay, if it is OK, check relay connector, engine-vehicle cable harness connector and VEHICLE connector of the Marelli control unit: if not OK, restore; if OK, check continuity of cable harness (Brown/Black cable)

Coil

Function

Spark generation

Operation / Operating principle

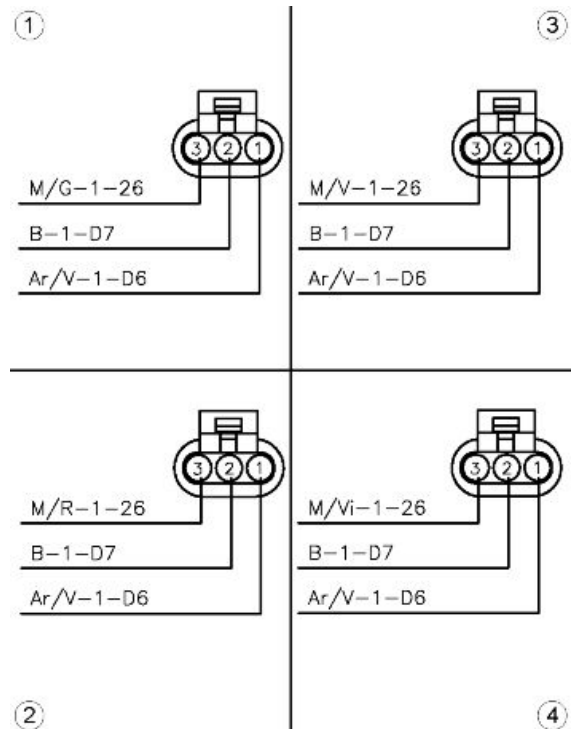
Inductive discharge system

Level in electrical circuit diagram:

coils and injectors

Location:

- on the vehicle: on the head covers.
- connector: For each 3-ways black coil connector. Coil 1 with short cable: on the left on the filter box, rear side; coil 2 with long cable: on the left of the front side of the filter box (connector with red strap on engine cable harness), coil 3 with long cable: on the left on the rear side of the filter box (connector with red



strap on engine cable harness); coil 4 with short cable: on the right of the front side of the filter box.



Electrical specifications:

0.7 - 0.9 Ω at ambient temperature

Pin out:

1. Power supply + Vbatt
2. Secondary circuit to ground
3. Activation from control unit

DIAGNOSTICS INSTRUMENT: PARAMETERS

Example value with key ON: Current ignition advance

Example value with engine on: Indicates the cylinder advance where combustion will take place.

CAUTION

BEFORE CARRYING OUT ANY TROUBLESHOOTING, CAREFULLY READ THE GENERAL TROUBLESHOOTING CONCEPTS FOR ELECTRICAL DEVICES AT THE BEGINNING OF THE CHECK AND CONTROL SECTION IN THE ELECTRICAL SYSTEM CHAPTER.

DIAGNOSTICS INSTRUMENT: ACTIVATION

Coil 1:

The injection relay (No. 33 in the wiring diagram, placed under the saddle, next to the battery positive CHECK, however, the identification of the relay with the colour of the cables) is energised for 5 seconds and the brown/yellow cable of the coil is closed to ground for 2 ms per second. Disconnect the 4-way connector of the fuel pump to be able to hear the relay and injector activation. The continuity of the wiring is necessary for correct activation: no error indications are displayed in case of lack of activation.

Coil 2:

The injection relay (No. 33 in the wiring diagram, placed under the saddle, next to the battery positive CHECK, however, the identification of the relay with the colour of the cables) is energised for 5 seconds and the brown/red cable of the coil is closed to ground for 2 ms per second. Disconnect the 4-way connector of the fuel pump to be able to hear the relay and injector activation. The continuity of the wiring is necessary for correct activation: no error indications are displayed in case of lack of activation.

Coil 3:

The injection relay (No. 33 in the wiring diagram, placed under the saddle, next to the battery positive CHECK, however, the identification of the relay with the colour of the cables) is energised for 5 seconds and the brown/green cable of the coil is closed to ground for 2 ms per second. Disconnect the 4-way connector of the fuel pump to be able to hear the relay and injector activation. The continuity of the wiring is necessary for correct activation: no error indications are displayed in case of lack of activation.

Coil 4:

The injection relay (No. 33 in the wiring diagram, placed under the saddle, next to the battery positive CHECK, however, the identification of the relay with the colour of the cables) is energised for 5 seconds and the brown/purple cable of the coil is closed to ground for 2 ms per second. Disconnect the 4-way connector of the fuel pump to be able to hear the relay and injector activation. The continuity of the wiring is necessary for correct activation: no error indications are displayed in case of lack of activation.

DIAGNOSIS INSTRUMENT: LOGIC ERRORS

Coil 1 P0351

- shorted to positive / shorted to negative, open circuit.

Error cause

- If shorted to positive: excessive voltage has been detected at PIN 28 of the ENGINE connector. If the circuit is open, shorted to negative: voltage equal to zero has been detected at PIN 28 of the ENGINE connector.

Troubleshooting

- If shorted to positive: disconnect the coil connector, set the key to ON, activate the coil with Navigator and check voltage at connector PIN 28: if there is voltage, restore the cable harness; if voltage = 0, replace the coil.
- If the circuit is open, shorted to negative: check electric characteristics of the coil: if not OK, replace the coil, if OK check the coil connector and the Marelli control unit connector; if not OK, restore, if OK, check cable continuity between the two cable terminals: if there is not continuity, restore the cable harness; if there is cable continuity, with key set to ON, check the ground insulation of the cable (from coil connector or control unit connector), if not OK, restore cable harness.

Coil 2 P0352

- shorted to positive / shorted to negative, open circuit.

Error cause

- If shorted to positive: excessive voltage has been detected at PIN 27 of the ENGINE connector. If the circuit is open, shorted to negative: voltage equal to zero has been detected at PIN 27 of the ENGINE connector

Troubleshooting

- If shorted to positive: disconnect the coil connector, set the key to ON, activate the coil with Navigator and check voltage at connector PIN 27: if there is voltage, restore the cable harness; if voltage = 0, replace the coil.
- If the circuit is open, shorted to negative: check electric characteristics of the coil: if not OK, replace the coil, if OK check the coil connector and the Marelli control unit connector; if not OK, restore, if OK, check cable continuity between the two cable terminals: if there is not continuity, restore the cable harness; if there is cable continuity, with key set to ON, check

the ground insulation of the cable (from coil connector or control unit connector), if not OK, restore cable harness.

Coil 3 P0353

- shorted to positive / shorted to negative, open circuit.

Error cause

- If shorted to positive: excessive voltage has been detected at PIN 2 of the ENGINE connector. If the circuit is open, shorted to negative: voltage equal to zero has been detected at PIN 2 of the ENGINE connector.

Troubleshooting

- If shorted to positive: disconnect the coil connector, set the key to ON, activate the coil with Navigator and check voltage at connector PIN 2: if there is voltage, restore the cable harness; if voltage = 0, replace the coil.
- If the circuit is open, shorted to negative: check electric characteristics of the coil: if not OK, replace the coil, if OK check the coil connector and the Marelli control unit connector; if not OK, restore, if OK, check cable continuity between the two cable terminals: if there is not continuity, restore the cable harness; if there is cable continuity, with key set to ON, check the ground insulation of the cable (from coil connector or control unit connector), if not OK, restore cable harness.

Coil 4 P0354

- shorted to positive / shorted to negative, open circuit.

Error cause

- If shorted to positive: excessive voltage has been detected at PIN 1 of the ENGINE connector. If the circuit is open, shorted to negative: voltage equal to zero has been detected at PIN 1 of the ENGINE connector.

Troubleshooting

- If shorted to positive: disconnect the coil connector, set the key to ON, activate the coil with Navigator and check voltage at connector PIN 1: if there is voltage, restore the cable harness; if voltage = 0, replace the coil.
 - If the circuit is open, shorted to negative: check electric characteristics of the coil: if not OK, replace the coil, if OK check the coil connector and the Marelli control unit connector; if not OK, restore, if OK, check cable continuity between the two cable terminals: if there is not continuity, restore the cable harness; if there is cable continuity, with key set to ON, check the cable ground insulation (from coil connector or control unit connector), if not OK, restore cable harness
-

Throttle body

Function

Sends to the injection control unit the throttle position and activates the throttle according to the control unit

Operation / Operating principle

All the unit internal components (potentiometer and electric motor) are contactless; therefore, no electrical diagnosis is possible for the throttle body, but for the circuits connected to it only.

Level in electrical circuit diagram:

Throttle check and handle grip sensor (Demand)

Location:

- on the vehicle: inside the filter box
- connector: on the throttle body, in lower position, near the throttle motors

Pin out:

1. potentiometer signal 1
2. supply voltage + 5V
3. throttle valve control (+)
4. potentiometer signal 2
5. throttle valve control (+)
6. ground connection

DIAGNOSIS INSTRUMENT: PARAMETERS

Front cylinder throttle correction

- Example value with key ON: 0.0°
- Example value with engine on: 0.4°

The system, reading the intake pressure, tries to balance the intake pressures between the cylinders of the rear bank (1-3) and of the front bank (2-4) working on the throttle position: an acceptable value should be between -0.5 and + 0.5

Rear cylinder throttle correction

- Example value with key ON: 0.0°
- Example value with engine on: -0.2°

The system, reading the intake pressure, tries to balance the intake pressures between the cylinders of the rear bank (1-3) and of the front bank (2-4) working on the throttle position: an acceptable value should be between -0.5 and + 0.5

Front throttle Potentiometer 1 (degrees)

- Example value with key ON: 7.8°
- Example value with engine on: 1.4°

With key set to ON, the throttle is kept in position by the springs (around 5 -7°). After the engine starts up at idle, the throttle is kept close to the mechanical minimum (above or equal to 0.5°). When the gear

is not engaged, at approx. 6000 rpm, throttles open very little because the requested torque is too low (around 5-7°)

Rear throttle Potentiometer 1 (degrees)

- Example value with key ON: 8°
- Example value with engine on: 1.5°

With key set to ON, the throttle is kept in position by the springs (around 5 -7°). After the engine starts up at idle, the throttle is kept close to the mechanical minimum (above or equal to 0.5°). When the gear is not engaged, at approx. 6000 rpm, throttles open very little because the requested torque is too low (around 5-7°)

Front throttle Potentiometer 1 (voltage)

- Example value with key ON: 873 mV
- Example value with engine on: 561 mV

Rear throttle Potentiometer 1 (voltage)

- Example value with key ON: 883 mV
- Example value with engine on: 536 mV

Front throttle Potentiometer 2 (voltage)

- Example value with key ON: 4123 mV
- Example value with engine on: 4426 mV

Rear throttle Potentiometer 2 (voltage)

- Example value with key ON: 4113 mV
- Example value with engine on: 4455 mV

Front throttle Potentiometer 2 (degrees)

- Example value with key ON: 8.0°
- Example value with engine on: 1.5°

With key set to ON, the throttle is kept in position by the springs (around 5 -7°). After the engine starts up at idle, the throttle is kept close to the mechanical minimum (above or equal to 0.5°). When the gear is not engaged, at approx. 6000 rpm, throttles open very little because the requested torque is too low (around 5-7°)

Rear throttle Potentiometer 2 (degrees)

- Example value with key ON: 8.2°
- Example value with engine on: 1.6°

With key set to ON, the throttle is kept in position by the springs (around 5 -7°). After the engine starts up at idle, the throttle is kept close to the mechanical minimum (above or equal to 0.5°). When the gear is not engaged, at approx. 6000 rpm, throttles open very little because the requested torque is too low (around 5-7°)

Front cylinders throttle Limp Home position

- Example value with key ON: 878 mV

Voltage stored in the control unit corresponding to the Limp home position

Rear cylinders throttle Limp Home position

- Example value with key ON: 888 mV

Voltage stored in the control unit corresponding to the Limp home position

Front throttle lower position

- Example value with key ON: 502 mV

Voltage stored in the control unit corresponding to the throttle mechanical minimum position

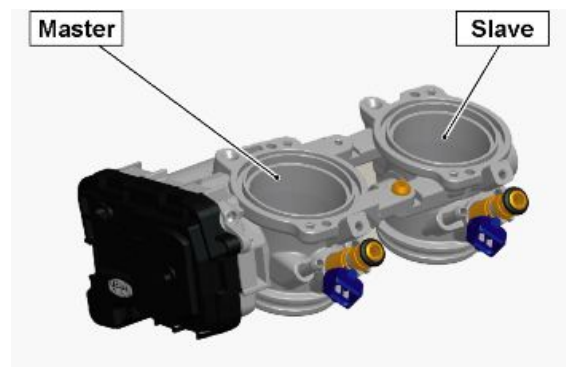
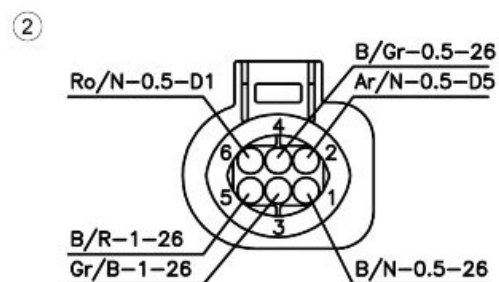
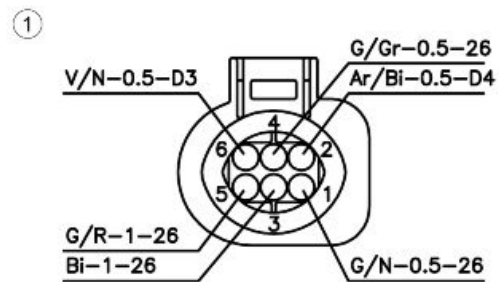
Rear throttle lower position

- Example value with key ON: 492 mV

Voltage stored in the control unit corresponding to the throttle mechanical minimum position

CAUTION

BEFORE CARRYING OUT ANY TROUBLESHOOTING, CAREFULLY READ THE GENERAL TROUBLESHOOTING CONCEPTS FOR ELECTRICAL DEVICES AT THE BEGINNING OF THE CHECK AND CONTROL SECTION IN THE ELECTRICAL SYSTEM CHAPTER.

**DIAGNOSTICS INSTRUMENT: STATUSES****Front throttle automatic self-learning**

- ice/ interrupted/carried out/limp home/closed throttle stop/springs check/limp home self-acquisition/initialise

Indicates if self-acquisition carried out by control unit has/has not been carried out: it is essential to know if the last self-acquisition with key ON has been successful

Rear throttle automatic self-learning

- ice/ interrupted/carried out/limp home/closed throttle stop/springs check/limp home self-acquisition/initialise

Indicates if self-acquisition carried out by control unit has/has not been carried out: it is essential to know if the last self-acquisition with key ON has been successful

Throttle self-learning with diagnostics instrument

- carried out/not carried out

Indicates whether the self-acquisition process through the diagnostics instrument has/has not been carried out: if it has been carried out once, will always be carried out unless EEPROM control unit zero setting is carried out

DIAGNOSTICS INSTRUMENT: ELECTRICAL ERRORS

CAUTION

IF ERRORS ARE DETECTED ON BOTH THROTTLE BODIES, CHECK ALSO THE CORRECT SUPPLY OF THE CONTROL UNIT TO PIN 42.

potentiometer 1 sensor, rear throttle position P0120

- short circuit to positive / open circuit, short circuit to negative

Error cause

- If shorted to positive: excessive voltage has been detected at PIN 48. If the circuit is open, shorted to negative: voltage equal to zero has been detected at PIN 48.

Troubleshooting

- If shorted to positive: check the value shown by the parameter of the Rear throttle Potentiometer 1 (voltage): disconnect the connector and see the value displayed by Navigator: if the voltage does not vary, there is a short circuit in the cable; replace the throttle body if the voltage drops to zero
- If the circuit is open, shorted to negative: check the throttle body connector and the control unit connector. If not OK, restore; if everything is OK, check circuit continuity between the two terminals. If not OK, restore the cable harness; if OK, check the circuit ground insulation (from throttle sensor connector or control unit connector). If it is ground insulated, check that there is power (+5 V) at the throttle body connector PIN 2, and that PIN 6 is connected to ground. If both are correct, replace the throttle body

potentiometer 2 sensor, rear throttle position P0122

- short circuit to positive / open circuit, short circuit to negative

Error cause

- If shorted to positive: excessive voltage has been detected at PIN 50. If the circuit is open, shorted to negative: voltage equal to zero has been detected at PIN 50.

Troubleshooting

- If shorted to positive: check the value shown by the parameter of the Front throttle Potentiometer 2 (voltage): disconnect the connector and see the value displayed by Navigator: if the voltage does not vary, there is a short circuit in the cable; replace the throttle body if the voltage drops to zero
- If the circuit is open, shorted to negative: check the throttle body connector and the control unit connector. If not OK, restore; if everything is OK, check circuit continuity between the two terminals. If not OK, restore the cable harness; if OK, check the circuit ground insulation

(from throttle sensor connector or control unit connector). If it is ground insulated, check that there is power (+5 V) at the throttle body connector PIN 2, and that PIN 6 is connected to ground. If both are correct, replace the throttle body

potentiometer 1 sensor, front throttle position P0125

- short circuit to positive / open circuit, short circuit to negative

Error cause

- If shorted to positive: excessive voltage has been detected at PIN 36. If the circuit is open, shorted to negative: voltage equal to zero has been detected at PIN 36

Troubleshooting

- If shorted to positive: check the value shown by the parameter of the Rear throttle Potentiometer 1 (voltage): disconnect the left connector and see the value displayed by Navigator: if the voltage does not vary, there is a short circuit in the cable wiring; replace the throttle body if the voltage drops to zero.
- If the circuit is open, shorted to negative: check the throttle body connector and the control unit connector. If not OK, restore; if everything is OK, check circuit continuity between the two terminals. If not OK, restore the cable harness; if OK, check the circuit ground insulation (from throttle sensor connector or control unit connector). If it is ground insulated, check that there is power (+5 V) at the throttle body connector PIN 2, and that PIN 6 is connected to ground. If both are correct, replace the throttle body

potentiometer 2 sensor, front throttle position P0127

- short circuit to positive / open circuit, short circuit to negative

Error cause

- If shorted to positive: excessive voltage has been detected at PIN 21. If the circuit is open, shorted to negative: voltage equal to zero has been detected at PIN 21.

Troubleshooting

- If shorted to positive: check the value shown by the parameter of the rear Throttle Potentiometer 2 (voltage): disconnect the left connector and see the value displayed by Navigator: if the voltage does not vary, there is a short circuit in the cable wiring; replace the throttle body if the voltage drops to zero.
- If the circuit is open, shorted to negative: check the throttle body connector and the control unit connector. If not OK, restore; if everything is OK, check circuit continuity between the two terminals. If not OK, restore the cable harness; if OK, check the circuit ground insulation (from throttle sensor connector or control unit connector). If it is ground insulated, check that there is power (+5 V) at the throttle body connector PIN 2, and that PIN 6 is connected to ground. If both are correct, replace the throttle body

Rear throttle control circuit P0166

- short circuit to positive / short circuit to negative / open circuit, overvoltage, excessive internal temperature

Error cause

- If shorted to positive: excessive voltage has been detected at PIN 29 - 41. If shorted to negative: no voltage has been detected. If the circuit is open: an interruption or excessive ampere input or control unit overheating has been detected

Troubleshooting

- If shorted to positive: disconnect the throttle body connector, set key to ON and check voltage at PIN 3: if the voltage read is higher or equal to 5V, there is a short circuit on the cable harness; replace the throttle body if the voltage is null
- If shorted to negative: disconnect the throttle body connector, set the key to ON and check if PIN 3 is in continuity with the vehicle ground connection: if there is continuity, restore the cable harness; if there is not continuity, replace the throttle body
- If the circuit is open, there is overvoltage or excessive internal temperature: check the throttle body connector and the control unit connector: if not OK, restore; if OK, disconnect the throttle body connector and control unit connector and check if there is cables continuity; if there is no continuity, restore the cable harness. If there is continuity, with the throttle body connector connected, check that the resistance, from the throttle control unit connector, between PIN 29 and 41 is within 1 and 2.5 Ohm; if it is not, replace the throttle body; if it is, check that the throttle body is not mechanically blocked: if blocked, solve the problem and replace the body; if it is not, replace the control unit

Front throttle control circuit P0186

- short circuit to positive / short circuit to negative / open circuit, overvoltage, excessive internal temperature circuit open

Error cause

- If shorted to positive: excessive voltage has been detected at PIN 3 - 15. If shorted to negative: no voltage has been detected. If the circuit is open: an interruption or excessive ampere input or control unit overheating has been detected

Troubleshooting

- If shorted to positive: disconnect the throttle body connector, set key to ON and check voltage at PIN 3: if the voltage read is higher or equal to 5V, there is a short circuit on the cable harness; replace the throttle body if the voltage is null
- If shorted to negative: disconnect the throttle body connector, set the key to ON and check if PIN 3 is in continuity with the vehicle ground connection: if there is continuity, restore the cable harness; if there is not continuity, replace the throttle body
- If the circuit is open, there is overvoltage or excessive internal temperature: check the throttle body connector and the control unit connector: if not OK, restore; if OK, disconnect the

throttle body connector and control unit connector and check if there is cables continuity; if there is no continuity, restore the cable harness. If there is continuity, with the throttle body connector connected, check that the resistance, from the throttle control unit connector, between PIN 3 and 15 is within 1 and 2.5 Ohm; if it is not, replace the throttle body; if it is, check that the throttle body is not mechanically blocked: if blocked, solve the problem and replace the body; if it is not, replace the control unit

DIAGNOSIS INSTRUMENT: LOGIC ERRORS

potentiometer 1 sensor, rear throttle position P0121

- signal not valid

Error cause

- Signal not within the expected value drawn according to the values of the intake pressure

Troubleshooting

- Check the parameter of the Potentiometer 1 front Throttle (voltage) to get which signal the control unit receives and to compare it to the Potentiometer 1 rear Throttle (voltage). Check the throttle body connector as well as the control unit connector. Check that cable resistance between the throttle body connector (PIN 1) and the control unit (PIN48) is a few tenths of an Ohm. If this is not the case, restore the cable harness. If the value is correct, replace the complete throttle body

potentiometer 2 sensor, rear throttle position P0123

- signal not valid

Error cause

- Signal not within the expected value drawn according to the values of the intake pressure

Troubleshooting

- Check the parameter of the Potentiometer 2 front Throttle (voltage) to get which signal the control unit receives and to compare it to the Potentiometer 2 rear Throttle (voltage). Check the throttle body connector as well as the control unit connector. Check that cable resistance between the throttle body connector (PIN 4) and the control unit (PIN 50) is a few tenths of an Ohm. If this is not the case, restore the cable harness. If the value is correct, replace the complete throttle body

rear throttle position potentiometer P0124

- incongruent signal

Error cause

- Potentiometer 1 and potentiometer 2 do not show a logical value: the sum of the two voltages should be constant. The cause may be a malfunction in one of the two sensors or an abnormal resistance in one of the two circuits

Troubleshooting

- Check the throttle body connector as well as the control unit connector. Check that cable resistance between the throttle body connector (PIN 1) and the control unit (PIN 48) is a few tenths of an Ohm. Check that cable resistance between the throttle body connector (PIN 4) and the control unit (PIN 50) is a few tenths of an Ohm. If one of the two is different, restore the cable harness. If correct, replace the complete throttle body.

potentiometer 1 sensor, front throttle position P0126

- signal not valid

Error cause

- Signal not within the expected value drawn according to the values of the intake pressure

Troubleshooting

- Check the parameter of the Potentiometer 1 rear throttle (voltage) to get which signal the control unit receives and to compare it to the Potentiometer 1 front throttle (voltage). Check the throttle body connector as well as the control unit connector. Check that cable resistance between the throttle body connector (PIN 1) and the control unit (PIN 36) is a few tenths of an Ohm. If this is not the case, restore the cable harness. If the value is correct, replace the complete throttle body

potentiometer 2 sensor, front throttle position P0128

- signal not valid

Error cause

- Signal not within the expected value drawn according to the values of the intake pressure

Troubleshooting

- Check the parameter of the Potentiometer 2 rear throttle (voltage) to get which signal the control unit receives and to compare it to the Potentiometer 2 front throttle (voltage). Check the throttle body connector as well as the control unit connector. Check that cable resistance between the throttle body connector (PIN 4) and the throttle control unit (PIN 21) is a few tenths of an Ohm. If this is not the case, restore the cable harness. If the value is correct, replace the complete throttle body

front throttle position potentiometer P0129

- incongruent signal

Error cause

- Potentiometer 1 and potentiometer 2 do not show a logical value: the sum of the two voltages should be constant. The cause may be a malfunction in one of the two sensors or an abnormal resistance in one of the two circuits

Troubleshooting

- Check the throttle body connector as well as the control unit connector. Check that cable resistance between the throttle body connector (PIN 1) and the control unit (PIN 36) is a few tenths of an Ohm. Check that cable resistance between the throttle body connector (PIN 4) and the throttle control unit (PIN 21) is a few tenths of an Ohm. If one of the two is different, restore the cable harness. If correct, replace the complete throttle body.

Rear throttle Limp Home self-acquisition P0160

- failed test

Error cause

- Throttle position, kept by the springs, not within the expected range (at each key ON). The instrument panel does not indicate the presence of this error even in the ATT status

Troubleshooting

- Check if the throttle body and the intake duct are clean. If OK, replace the throttle body

Rear throttle mechanical springs self-acquisition P0161

- failed test

Error cause

- Return time of the throttle, kept in position by the springs, not within the expected limits: the causes can be a deterioration of the performance of the springs or excessive throttle friction (at each key ON)

Troubleshooting

- Check if the throttle body and the intake duct are clean. If OK, replace the throttle body

Rear throttle minimum mechanical position self-acquisition P0162

- failed test

Error cause

- Position of the throttle stop not within the expected field (at each key ON)

Troubleshooting

- Check if the throttle body and the intake duct are clean. If OK, replace the throttle body

Detection of the rear throttle Recovery conditions (air temp., water temp.) P0163

- possible presence of ice

Error cause

- A correct throttle rotation cannot be detected given low ambient and engine temperatures: some ice may have formed in the duct (at each key ON). The instrument panel does not indicate the presence of this error even in the ATT status

Troubleshooting

- Check that the throttle body is clean and that there is no ice or condensation in the intake duct. If OK, replace the throttle body

Rear throttle power supply voltage during self-learning P0164

- low supply voltage

Error cause

- The throttle power supply voltage is too low to carry out the self-acquisition test correctly (at each key ON). The instrument panel does not indicate the presence of this error even in the ATT status

Troubleshooting

- Delete errors hindering throttle self-learning.

Rear throttle position error P0167

- misalignment between control and activation

Error cause

- The throttle mechanical control may be damaged

Troubleshooting

- Replace the throttle body

Front throttle Limp Home self-acquisition P0180

- failed test

Error cause

- Throttle position, kept by the springs, not within the expected range (at each key ON). The instrument panel does not indicate the presence of this error even in the ATT status

Troubleshooting

- Check if the throttle body and the intake duct are clean. If OK, replace the throttle body

Front throttle mechanical springs self-acquisition P0181

- failed test

Error cause

- Return time of the throttle, kept in position by the springs, not within the expected limits: the causes can be a deterioration of the performance of the springs or excessive throttle friction (at each key ON)

Troubleshooting

- Check if the throttle body and the intake duct are clean. If OK, replace the throttle body

Front throttle minimum mechanical position self-acquisition P0182

- failed test

Error cause

- Position of the throttle stop not within the expected field (at each key ON)

Troubleshooting

- Check if the throttle body and the intake duct are clean. If OK, replace the throttle body

Detection of the front throttle Recovery conditions (air temp., water temp.) P0183

- possible presence of ice

Error cause

- A correct throttle rotation cannot be detected given low ambient and engine temperatures: some ice may have formed in the duct (at each key ON). The instrument panel does not indicate the presence of this error even in the ATT status

Troubleshooting

- Check that the throttle body is clean and that there is no ice or condensation in the intake duct. If OK, replace the throttle body

Front throttle power supply voltage during self-learning P0184

- low supply voltage

Error cause

- The throttle power supply voltage is too low to carry out the self-acquisition test correctly (at each key ON). The instrument panel does not indicate the presence of this error even in the ATT status

Troubleshooting

- Delete errors hindering throttle self-learning.

Front throttle position error P0187

- misalignment between control and activation

Error cause

- The throttle mechanical control may be damaged

Troubleshooting

- Replace the throttle body

DIAGNOSIS INSTRUMENT: ADJUSTABLE PARAMETERS

Throttle Self-learning

NOTE

THROTTLE BODY ACTIVATION TAKES PLACE EVERY TIME THE KEY IS SET TO ON: CORRECT ACTIVATION IS INDICATED WHEN THE STOP LIGHTS TURN ON: IF DURING ACTIVATION, THE

ENGINE IS STARTED, THE ACTIVATION IS NOT COMPLETED AND THE STOP LIGHTS DO NOT TURN ON. EVERY 150 KEY-ONS, HOWEVER, THE THROTTLE VALVES ARE FORCED TO ACTIVATION. IF START-UP IS ATTEMPTED DURING THIS ACTIVATION (WHICH REQUIRES 3 SECONDS), THE ENGINE WILL NOT START.

FITTING: MECHANICAL/ELECTRICAL REFIT

RESET PROCEDURE

If a throttle body is replaced, after key is set to ON, do not start the engine within the 3 seconds; during this time the control unit carries out the throttle self-acquisition process: according to the throttle body replaced check that the status "Front throttle automatic self-learning" or "Rear throttle automatic self-learning" indicates: "carried out". If indication is not "Carried out", delete possible errors on the vehicle and then, with key set to ON, check that the statuses are "Carried out". If necessary, carry out "Throttle self-learning" process on the adjustable parameters screen page (screwdriver and hammer), and check again that the "Throttle self-learning with diagnostics instrument" status indicates: "Carried out" and that the "Front throttle automatic self-learning" or "Rear throttle automatic self-learning" indicate: "carried out"

Engine oil pressure sensor

Function

Indicates the instrument panel if there is enough oil pressure (0.5 +/-0.2 bar) in the engine.

Operation / operating principle

Normally closed switch (grounds the control unit signal); with pressure values above 0.5 ± 0.2 bar, the switch is tripped.

Level in wiring diagram:

Low fuel and oil pressure

Location:

- on the vehicle: front side of the engine, next to the oil filter.
- connector: on the sensor.

Electrical specifications: -

Pin out:

1. Voltage: 5 V

CAUTION

BEFORE CARRYING OUT ANY TROUBLESHOOTING, CAREFULLY READ THE GENERAL TROUBLESHOOTING CONCEPTS FOR ELECTRICAL DEVICES AT THE BEGINNING OF THE CHECK AND CONTROL SECTION IN THE ELECTRICAL SYSTEM CHAPTER.

INSTRUMENT PANEL

DSB 07: Oil pressure sensor



Error cause

- An oil sensor fault is signalled when, with engine off, it is detected that the sensor circuit is open. The test is performed only once when the key is set to ON. There is an error when the general warning light turns on.

Troubleshooting

- Check the sensor connector and the instrument panel connector (PIN 17): if they are not OK, restore. If OK, check continuity of the purple cable between the sensor connector and the instrument panel connector PIN 17: if not OK, restore the cable harness; if OK, replace the sensor.

DSB 08: Oil pressure

Error cause

- An oil sensor fault is signalled when, with engine running, it is detected that the sensor circuit is closed. There is an error when the general warning light turns on.

Troubleshooting

- Check if oil pressure is low with the specific gauge.

Neutral sensor

Function

It tells the gear position to the control unit, from the 1st gear to the 6th gear, and if the gear is neutral or riding.

Operation / Operating principle

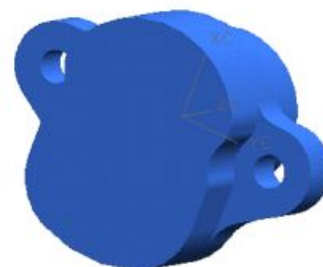
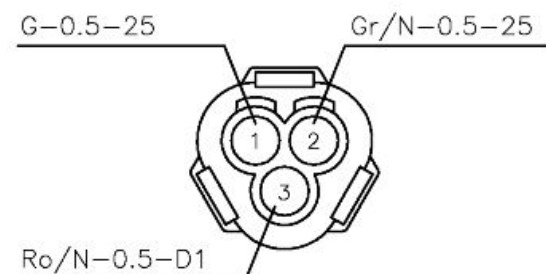
The sensor has 2 circuits: one to indicate the engaged gear, whose resistance varies according to the engaged gear: in this way, the injection ECU, according to detected electric voltage, identifies the engaged gear and sends the information via CAN to the instrument panel; the other indicates neutral gear, whose voltage is taken to zero if in neutral position.

Level in electrical circuit diagram:

Start-up enabling switches

Location:

- on the vehicle: under chain pinion, behind the pinion cover.



- connector: between head cover and filter box on left side (3-ways white connector).

Electrical specifications:

PIN 64: gear indication: closed circuit (continuity);

gear engaged: open circuit (infinite resistance).

Gear engaged circuit resistance: 1st gear: 0.8 kohm, 2nd gear 0.5 kohm, 3rd gear 15.0 kohm, 4th gear 6.9 kohm, 5th gear 2.8 kohm, 6th gear 1.5 kohm.

Pin out:

White/Black: ground from ECU, Light Blue: + 12V from ECU (gear), Pink: + 5V from ECU (gears).

CAUTION

BEFORE CARRYING OUT ANY TROUBLESHOOTING, CAREFULLY READ THE GENERAL TROUBLESHOOTING CONCEPTS FOR ELECTRICAL DEVICES AT THE BEGINNING OF THE CHECK AND CONTROL SECTION IN THE ELECTRICAL SYSTEM CHAPTER.

DIAGNOSTICS INSTRUMENT: STATUSES

Gearbox in neutral

- Yes/No

Gear engaged: 0 - 1 - 2- 3 - 4 - 5 - 6

DIAGNOSTICS INSTRUMENT: ELECTRICAL ERRORS

Gear sensor P0461

- shorted to positive or open circuit / shorted to negative.

Error cause

- If the circuit is open, shorted to positive: excessive voltage has been detected at PIN 72. If shorted to negative: voltage equal to zero has been detected at PIN 72.

Troubleshooting

- If the circuit is open, shorted to positive: the error is detected with gear engaged only. Check the sensor connector and the VEHICLE connector of the control unit: if not OK, restore; if they are OK, check the continuity of the Grey/Black cable between the two connectors: if not OK, restore; if they are OK, with key set to ON and control unit connector disconnected, check from the control unit side if the cable is in voltage: if it is in voltage, disconnect the sensor connector and check if the cable is in voltage: if it is in voltage, restore the cable harness; if it is not in voltage, replace the sensor (there is an interruption or shorted to positive of the Pink/Black cable in the section from the sensor connector to the sensor or inside the sensor).

- If shorted to negative: disconnect the sensor connector and with key set to ON, check Grey/Black cable voltage: if equal to zero, restore the cable harness; if equal to approx. 5 V, replace the sensor (there is short circuit to ground of the Pink/Black cable in the section from the sensor connector to the sensor or inside the sensor).

Clutch lever sensor

Function

It tells the clutch lever position to the control unit.

Operation / Operating principle

If there is gear engaged but the clutch is pulled, i.e. circuit closed to ground, vehicle start-up is not enabled.

Level in electrical circuit diagram:

Start-up enabling switches

Location:

- on the vehicle: on the handlebar.
- connector: on the sensor.

Electrical specifications:

- Clutch pulled: closed circuit (continuity)
- Clutch released: open circuit (infinite resistance).

Pin out:

1. voltage 5V
2. ground connection

CAUTION

BEFORE CARRYING OUT ANY TROUBLESHOOTING, CAREFULLY READ THE GENERAL TROUBLESHOOTING CONCEPTS FOR ELECTRICAL DEVICES AT THE BEGINNING OF THE CHECK AND CONTROL SECTION IN THE ELECTRICAL SYSTEM CHAPTER.

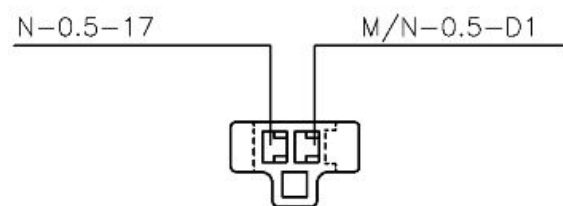
DIAGNOSIS INSTRUMENT: STATUSES

Clutch

- Indefinite_Released_Pulled

WARNING The statuses regularly viewed are Released and Pulled.

- Indication on Navigator always released: check the sensor connector, the engine-vehicle cable harness connector (special attention to PIN C3) and the control unit connector (special attention to PIN56): if not OK, restore cable harness; if OK, disconnect both terminals from



the sensor and check, with key set to ON, continuity to ground of PIN 2: if there is no continuity, restore the cable harness; if there is, replace the sensor.

- Indication on Navigator always pulled: disconnect the terminals from the sensor and check if there is continuity between the two PINS, with clutch released: if there is continuity, replace sensor; if the circuit is open, it means that there is short circuit to ground of black cable from sensor PIN 1 to engine-vehicle cable harness connector PIN C3 or of the white/purple cable from PIN C3 to VEHICLE connector PIN 56: restore the cable harness.

Side stand sensor

Function

it tells the side stand position to the control unit

Operation / Operating principle

If the gear is engaged and the side stand is unfolded, and therefore the circuit is open, the control unit does not enable vehicle start-up or shuts off the engine if it is rotating

Level in electrical circuit diagram:

Start-up enabling switches

Location:

- on the vehicle: on the stand
- connector: between head cover and filter box on left side (2-ways white connector)

Pin out:

1. Ground connection
2. Voltage 12V

Electrical specifications:

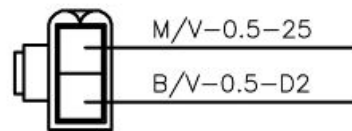
- Side Stand Up: closed circuit (continuity)
- Side Stand Down: open circuit (infinite resistance)

CAUTION

BEFORE CARRYING OUT ANY TROUBLESHOOTING, CAREFULLY READ THE GENERAL TROUBLESHOOTING CONCEPTS FOR ELECTRICAL DEVICES AT THE BEGINNING OF THE CHECK AND CONTROL SECTION IN THE ELECTRICAL SYSTEM CHAPTER.

DIAGNOSIS INSTRUMENT: STATUSES

Side stand sensor: up/down



- Indication on Navigator always down: check the connector: if not OK, restore; if it is OK, disconnect the two terminals from the sensor and check continuity to ground of PIN 1: if there is no continuity, restore the cable harness; if there is, replace the sensor
- Indication on Navigator always up: disconnect the terminals from the sensor and check if there is continuity between the two PINS, with stand down: if there is continuity, replace the sensor; if the circuit is open, it means that the brown/green cable from sensor PIN 2 to VEHICLE connector PIN 70 is short circuit to ground: restore the cable harness

Bank angle sensor

(if applicable)

Function

It tells the vehicle position to the control unit

Operation / Operating principle

When the sensor is inverted, the circuit is closed to ground: When the Marelli control unit detects this ground connection, it does not enable start-up or shuts off the engine.



Level in electrical circuit diagram:

Start-up enabling switches

Location:

- on the vehicle: sensor placed in the frame front niche.
- connector: next to the sensor (2-ways grey connector).



Electrical specifications:

- Sensor in vertical position: open circuit (resistance: 62 kOhm)
- Sensor inverted: closed circuit (continuity)

Pin out:

1. Ground connection
2. Voltage 5V

CAUTION

BEFORE CARRYING OUT ANY TROUBLESHOOTING, CAREFULLY READ THE GENERAL TROUBLESHOOTING CONCEPTS FOR ELECTRICAL DEVICES AT THE BEGINNING OF THE CHECK AND CONTROL SECTION IN THE ELECTRICAL SYSTEM CHAPTER.

DIAGNOSIS INSTRUMENT: STATUSES

Fall sensor: Normal / Tip over

- Indication on Navigator always Normal, even when the sensor is inverted: disconnect the connector and, with sensor inverted, check if there is continuity between the two PINS of the sensor: If there is not continuity, replace the sensor; if there is continuity, check the connector: if not OK, restore cable harness; if OK, check the ground continuity of PIN 1: if there is not continuity, restore cable harness; if there is continuity, check, with key ON, if there is voltage of 5 V at PIN 2; if there is not voltage, check Marelli control unit connector (with special attention to PIN 65) and check the vehicle-engine cable harness connector (with special attention to PIN B6).
- Indication on Navigator always Tip over: disconnect the connector and check if there is continuity between the two PINS when the sensor is in vertical position: if there is continuity, replace the sensor; if there is not, it means that, with key set to ON, there is no 5V voltage at PIN 2: restore the cable harness whose pink/white cable will be shorted to ground

CAUTION

BEFORE CARRYING OUT ANY TROUBLESHOOTING, CAREFULLY READ THE GENERAL TROUBLESHOOTING CONCEPTS FOR ELECTRICAL DEVICES AT THE BEGINNING OF THE CHECK AND CONTROL SECTION IN THE ELECTRICAL SYSTEM CHAPTER.

Electric fan circuit**Function**

Radiator fan and coolant - Operation

Operation / Operating principle

When the control unit detects a temperature of approx. 101 °C, it closes the fan control relay pickup circuit to ground

Level in electrical circuit diagram:

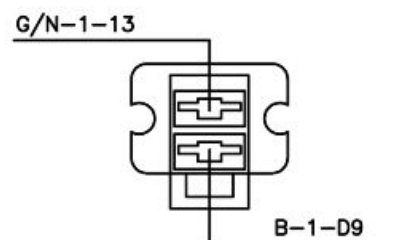
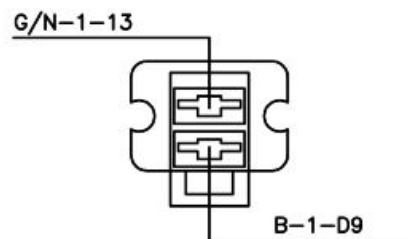
electric fan

Location:

- sensor: relay placed in the frame front niche, on the left
- connector: on the relay

Electrical characteristics:

- relay normally open;
- drive coil resistance 110 Ohm (+/- 10 %)

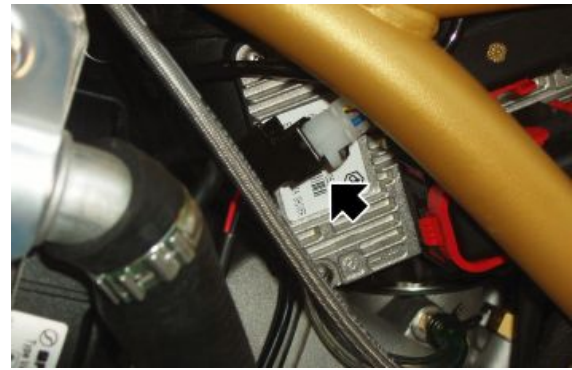
DIAGNOSIS INSTRUMENT: STATUSES**Fan relay**

- on/off

DIAGNOSIS INSTRUMENT: ACTIVATIONS

Fan

- The fan relay (No. 36 in the wiring diagram, placed in the headstock niche, left side; CHECK, however, the identification of the relay with the colour of the cables) is energised for 10 seconds. The continuity of the wiring is necessary for correct activation: no error indications are displayed in case of lack of activation



CAUTION

BEFORE CARRYING OUT ANY TROUBLESHOOTING, CAREFULLY READ THE GENERAL TROUBLESHOOTING CONCEPTS FOR ELECTRICAL DEVICES AT THE BEGINNING OF THE CHECK AND CONTROL SECTION IN THE ELECTRICAL SYSTEM CHAPTER.

DIAGNOSIS INSTRUMENT: ELECTRICAL ERRORS

Cooling fan relay P0480

- short circuit to positive/ short circuit to negative / open circuit

Error cause

- If shorted to positive: excessive voltage has been detected at PIN 61 of the VEHICLE connector. If shorted to negative: no voltage has been detected. If the circuit is open: 5V voltage has been detected. Error recognition carries out only when the fan relay is activated.

Troubleshooting

- If shorted to positive: check the relay electrical specifications are correct by disconnecting it from the cable harness. If not OK, replace the relay; if OK, restore the cable harness (brown cable)
- If shorted to negative: check the relay electrical specifications are correct by disconnecting it from the cable harness. If not OK, replace the relay; if OK, restore the cable harness (brown cable)
- If the circuit is open: check the relay electrical characteristics are correct by disconnecting it from the cable harness; if it is not OK, replace the relay, if it is OK, check relay connector, engine-vehicle cable harness connector and VEHICLE connector of the Marelli control unit: if not OK, restore; if OK, check continuity of cable harness (brown cable)

SAS valve actuator

Function

Quickly warms up the catalytic converter and keeps the combustion rich in some critical conditions

Operation / Operating principle

The valve coil is excited to open the air passage of the filter box to the exhaust manifold

Level in electrical circuit diagram:

Secondary air valve and lambda probe

Location:

- on the vehicle: under throttle bodies, in the V between the two front and rear cylinders banks
- connector: on the valve

Electrical characteristics:

Resistance at ambient temperature: $21 \pm 3 / - 1 \Omega$

Pin out:

1. Power supply V batt
2. Ground connection

DIAGNOSIS INSTRUMENT: PARAMETERS

Secondary air valve duty cycle

- Example value with key ON: 0 %
- Example value with engine on: %

Used only at 0 or 100%

CAUTION

BEFORE CARRYING OUT ANY TROUBLESHOOTING, CAREFULLY READ THE GENERAL TROUBLESHOOTING CONCEPTS FOR ELECTRICAL DEVICES AT THE BEGINNING OF THE CHECK AND CONTROL SECTION IN THE ELECTRICAL SYSTEM CHAPTER.

DIAGNOSIS INSTRUMENT: LOGIC ERRORS

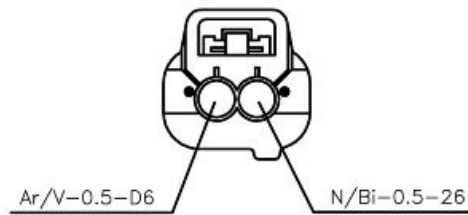
Secondary air valve control P0446

- short circuit to positive/ short circuit to negative / open circuit

Error cause

- If shorted to positive: excessive voltage has been detected at PIN 43. If shorted to negative/ open circuit: no voltage has been detected. The instrument panel does not indicate the presence of this error even in the ATT status.

Troubleshooting



- If shorted to positive: disconnect the component, set the key to ON, start the vehicle and check if the error symptom is still "shorted to positive": it means that short circuit is between black/white cable and a cable in voltage, therefore restore cable harness; if the error symptom is short circuit to ground, it means that short circuit is inside the valve and therefore, you must replace the component.
- If shorted to negative or open circuit: check the component connector and control unit connector: if not OK, restore; if OK, check the continuity of the black/white cable between the two connectors: if not OK, restore cable harness; if OK, with key ON, check if there is voltage at PIN 1: if there is not voltage, check orange/green cable; if there is voltage, check component electrical characteristics and replace the component

RUN/STOP switch

Function

It tells the control unit if the rider wishes to enable engine start-up or to keep the engine running.

Operation / Operating principle

If the rider wants to shut off the engine or to disable engine start-up, the switch should be open, i.e.

VEHICLE connector PIN 78 of the Marelli control unit must not be connected to ground.

Level in electrical circuit diagram:

Start-up enabling switches

Location:

- on the vehicle: right light switch.
- connector: inside the bow (4-ways black).

Electrical specifications:

- STOP position: the circuit is open
- RUN position: closed circuit (continuity)

Pin out:

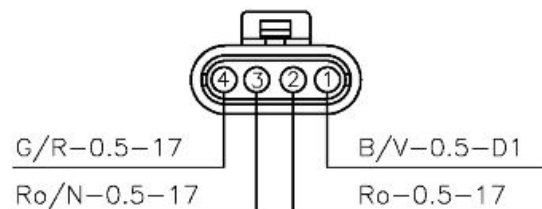
1 blue/green cable: ground connection

4 yellow/red cable: 5 V

CAUTION

BEFORE CARRYING OUT ANY TROUBLESHOOTING, CAREFULLY READ THE GENERAL TROUBLESHOOTING CONCEPTS FOR ELECTRICAL DEVICES AT THE BEGINNING OF THE CHECK AND CONTROL SECTION IN THE ELECTRICAL SYSTEM CHAPTER.

DIAGNOSIS INSTRUMENT: STATUSES



RUN / STOP switch

- Run/Stop

NOTES

- Indication on Navigator always STOP: disconnect the connector and, with the switch set to RUN, check if there is continuity towards the two cables switch - Blue/Green and Yellow/Red: If there is not continuity, replace the sensor; if there is continuity, check the connector: if not OK, restore the cable harness; if OK, check, with key set to ON, if there is voltage on Yellow/Red cable: if there is no voltage, restore the cable harness; if there is, check the Yellow/Red cable ground insulation: If there is continuity with ground connection, restore the cable harness; if OK, set the key to OFF and check the VEHICLE connector and the engine-vehicle cable harness connector: if not OK, restore; if OK, check continuity of the Pink cable between switch connector and PIN C7 of the engine-vehicle cable harness connector and between the PIN C7 and the VEHICLE connector PIN 78: if not OK, restore the cable harness; if OK, replace the Marelli control unit.
- Indication on Navigator always RUN: disconnect the connector and, with the switch set to STOP, check if there is continuity between the two cables of the switch: if there is continuity, replace the switch; if there is not continuity, it means that, with key set to ON, the Pink cable (between switch and the PIN C7 of the engine-vehicle cable harness connector or from the latter to the PIN 78 of the control unit connector) is shorted to positive: restore the cable harness.

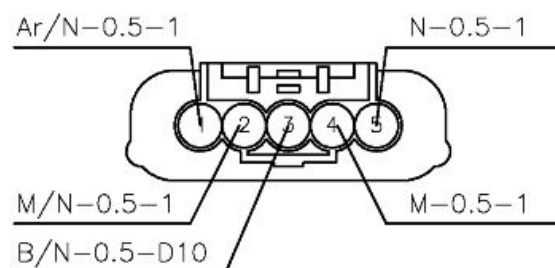
Butterfly valve in exhaust

Function

It is used to reduce exhaust noise. The exhaust butterfly valve is open, when a gear is engaged, in any condition, and closed in neutral if vehicle speed is equal to 0 km/h (if speed is different from zero, the valve is open).

Operation / Operating principle

The system consists of a throttle valve with a return spring placed on the exhaust pipe. The valve is closed via two cables actuated by an electric motor, which, in turn, is connected electrically to the instrument panel. The operating logic and motor control are, however, resident in the Marelli injection control unit, which dialogues with the instrument panel via the CAN.

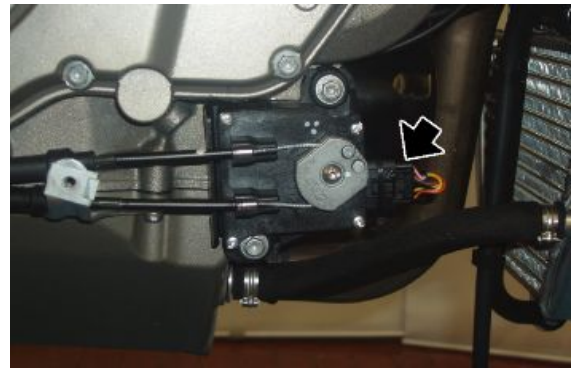


Level in electrical circuit diagram:

Exhaust butterfly valve

Location:

- on the vehicle: The motor is placed in the front lower part of the engine. The valve in the exhaust duct.
- connector: on the motor.

**Electrical characteristics:**

- Electrical motor resistance (PIN 4-5):
2--4 Ohm
- Potentiometer resistance (PIN 1-3):
10.1 kOhm +/- 10%

Pin out:

1. Power supply voltage 5V
2. Output signal (0- 5V)
3. Ground connection
4. Motor A supply
5. Motor B supply

DIAGNOSIS INSTRUMENT: PARAMETERS

Exhaust butterfly valve target position: 7 - 93 %

NOTE: Value that control unit sends to the instrument panel to activate the valve: 7% (closed valve), 93 % (open valve).

CAUTION

BEFORE CARRYING OUT ANY TROUBLESHOOTING, CAREFULLY READ THE GENERAL TROUBLESHOOTING CONCEPTS FOR ELECTRICAL DEVICES AT THE BEGINNING OF THE CHECK AND CONTROL SECTION IN THE ELECTRICAL SYSTEM CHAPTER.

DIAGNOSIS INSTRUMENT: STATUSES

Exhaust butterfly valve

- Indefinite/in research/activation with key ON/ in operation/stopped for detected malfunction/ research of zero position.

NOTE: If there is no problem, it appears: in operation

DIAGNOSIS INSTRUMENT: ELECTRICAL ERRORS

Exhaust butterfly valve stop research P0191

- potentiometer signal above maximum threshold/potentiometer signal below minimum threshold/excessive time/research not carried out or wrong stroke.

Error cause

- If potentiometer signal is above maximum threshold: voltage of the maximum end of stroke position (open valve) outside the foreseen field has been detected. If potentiometer signal is below maximum threshold: voltage of the minimum end of stroke position (closed valve) outside the foreseen field has been detected. If time is excessive: excessive time for stop search has been detected (possible mechanical problem of the valve, of the motor or cables not connected). If research has not been carried out or wrong stroke: this symptom may be caused when a new instrument panel is installed and the stop self-acquisition procedure is not carried out or if the stop between minimum and maximum is too short or too long.

Troubleshooting

- If potentiometer signal is above maximum threshold: during adjustment "Exhaust butterfly valve self-acquisition", voltage of maximum opening end of stroke outside the foreseen field is detected. Check correct tensioning of the two valve cables.
- If potentiometer signal is below maximum threshold: during adjustment "Exhaust butterfly valve self-acquisition", voltage of minimum opening end of stroke outside the foreseen field is detected. Check correct tensioning of the two valve cables.
- If time is excessive: check that the valve cables are in voltage: if they are not in voltage, fix them; if they are OK, check that mechanical rotation of the exhaust butterfly valve is without friction or deceleration: if they are not OK, restore normal valve rotation; if they are OK, check motor electrical characteristics: if they are not OK, replace the motor; if they are OK, check valve connector and instrument panel connector (with special attention to possible oxidation): if they are not OK, restore; if they are OK, replace the electrical motor. Or also free cables.
- If research has not been carried out or wrong stroke: adjust "Exhaust butterfly valve self-acquisition" if the stop self-acquisition procedure has not been carried out after installation of new instrument panel. If the instrument panel is not new, check correct calibration of the cables and if correct, check that there is not an obstacle for correct rotation of the valve.

Exhaust valve engine P0192

- open circuit, thermal overload protection, shorted to negative, shorted to positive or short circuit between both cables.

Error cause

- If the circuit is open: too low current has been detected at PIN 36 - 37 of the instrument panel connector. If thermal overload protection: instrument panel fault. If shorted to negative: voltage equal to zero has been detected. If shorted to positive or short circuit between both cables: excessive voltage has been detected.

Troubleshooting

- If the circuit is open: may occur due to loosen cables, therefore, make sure that cables are tight: if not tight, fix them; if cables are OK, check valve connector and instrument panel connector: if not OK, restore; if OK, check continuity of brown and black cables: if not OK, restore cable harness; if OK, check motor electrical characteristics and replace it.
- If thermal overload protection: replace the instrument panel.
- If shorted to negative: disconnect the valve connector and check, with key set to ON, if there is continuity with ground at PIN 4 of the connector: if there is ground connection, disconnect also the instrument panels connector and if it is still present, restore the brown cable; if there is not ground connection, replace the instrument panel; if there is not ground connection, check, with key set to ON, if there is continuity with ground connection at PIN 5 of the connector: if there is ground connection, disconnect also the instrument panel connector and if it is still present, restore the black cable; if there is not ground connection, replace the instrument panel; if there is not ground connection, check if PIN 4 or PIN 5 on the motor are in continuity with ground connection: if it is in continuity, replace the motor.
- If shorted to positive or short circuit between both cables: disconnect the instrument panel connector and check, with key set to ON if there is voltage on PIN 4 and PIN 5 of the connector: if there is, restore cable harness; if there is not, check, with key set to OFF and disconnecting also the valve connector, if both cables are insulated between them: if they are not insulated, restore cable harness; if insulated between them, it is possible that there is a shorted to positive inside the motor or instrument panel: it is necessary to replace one of the two components to identify which of them is faulty.

Exhaust valve potentiometer P0193

- shorted to positive / shorted to negative, open circuit.

Error cause

- If shorted to positive: excessive voltage has been detected at PIN 10 of the instrument panel.
If shorted to negative, the circuit is open: low voltage has been detected.

Troubleshooting

- If shorted to positive: disconnect the valve connector and check, with key set to ON, if there is voltage at PIN 2 of the connector: if there is voltage, disconnect also the instrument panel connector and if there is voltage, restore cable harness; if there is not voltage, replace instrument panel, if there is not voltage, replace motor.
- If shorted to negative, the circuit is open: check the valve connector and instrument panel connector: if not OK, restore; if OK, check continuity on the brown/black cable: if not OK, restore; if OK, always with two connectors disconnected, check ground insulation: if there is ground continuity, disconnect also the instrument panel and if it is still present, restore the cable harness; if there is not ground continuity, replace the instrument panel; if there is not ground continuity, replace the motor.

DIAGNOSTICS INSTRUMENT: LOGIC ERRORS

Exhaust butterfly valve position P0190

- position error.

Error cause

- Position indicated by potentiometer does not correspond with position set by control unit.

Troubleshooting

- Mechanically check the valve, its normal rotation (with cables disconnected from motor, manually activate the cables and see movement regularity and check valve complete stroke with correct operation of the return spring) and absence of foreign bodies which do not allow its rotation: if not OK, restore; if OK, check valve and instrument panel connectors (special attention to oxidation) and check cables resistance: if not OK, restore; if OK, always with cables disconnected and key set to ON, check normal rotation of the electric motor and replace motor (potentiometer does not work correctly).

DIAGNOSTICS INSTRUMENT: ADJUSTABLE PARAMETERS

- Acquire exhaust butterfly valve zero position.

NOTE: Motor is placed in a reference position to correctly search mechanical stop later.

- Exhaust butterfly valve self-acquisition

NOTE: Search minimum and maximum mechanical stop.

The system consists of a throttle valve (1) with a return spring placed in the exhaust pipe. The valve is closed via two cables actuated by an electric motor (2) which, in turn, is connected electrically to the instrument panel. The operating logic and motor control are, however, resident in the Marelli injection control unit, which dialogues with the instrument panel via the CAN.

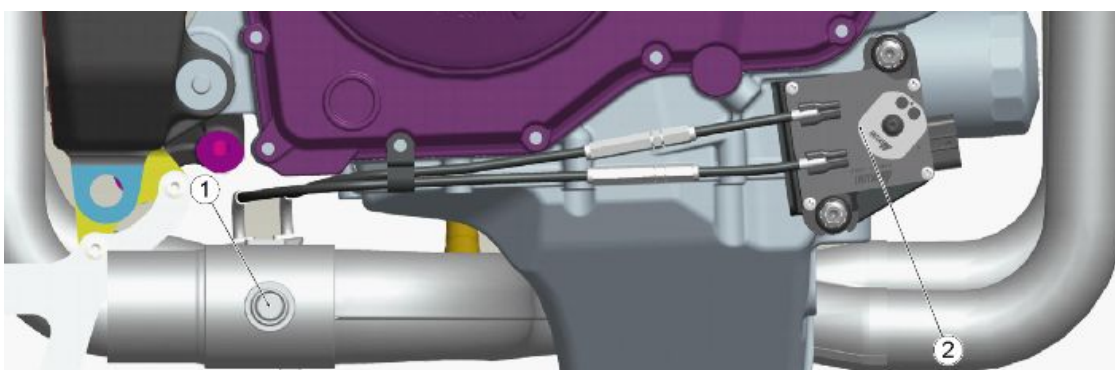
The motor unit (2) consists of a potentiometer for position detection and a DC electric motor (2).

At key-ON, a valve (1) self-cleaning cycle is performed.

In the event of malfunction (electric or mechanical), the valve (1) may remain stuck in the closed position.

In the event of a CAN line malfunction, the valve (1) is returned to the open position.

In the event of removal or replacement of one or more system components (cables, valve or motor), a calibration procedure is required.

**CAUTION**

BEFORE CARRYING OUT THIS OPERATION, CHECK THAT THE BATTERY VOLTAGE IS HIGHER THAN 12.5 V

CAUTION

OPERATE ON THE CONTROL MOTOR OF THE EXHAUST VALVE ONLY WITH THE KEY "OFF" OR ONLY AFTER DISCONNECTING THE NEGATIVE POLE OF THE BATTERY.

CAUTION

NEVER REMOVE THE PULLEY FROM THE CONTROL MOTOR

CAUTION

LOOSEN THE ADJUSTER SCREWS OF THE CONTROL CABLES BEFORE REMOVAL, TO AVOID HAVING TO FORCE THEM.

CAUTION

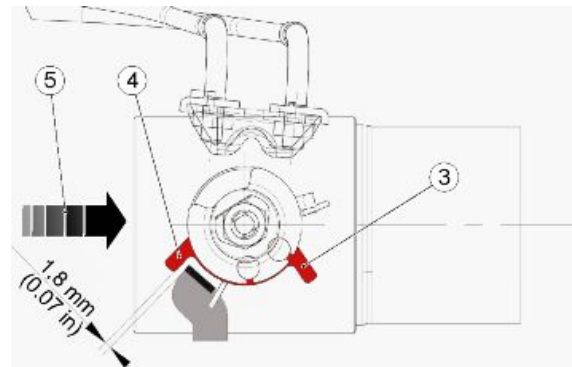
BEFORE REMOVING THE CONTROL CABLES, CHECK THAT THE MOTOR PULLEY IS IN THE "ZERO" POSITION. NEVER OPERATE ON THE CONTROL CABLES IF THE MOTOR PULLEY IS NOT IN THE "ZERO" POSITION

EXHAUST THROTTLE VALVE CALIBRATION

- Slacken the exhaust throttle valve cable tension.



- After having pressed the enter button for the zero position search, shut off the vehicle and leave the keys in OFF, even in the event that the instruments indicate the opposite.
- With the appropriate adjuster screw, tension the upper cable to leave approximately 1.8 mm (0.07 in) between the lock and opening travel limit (4) of the valve (1), with the appropriate adjuster screw, tension the lower cable so that the tensioning is as close as possible to that of the upper cable (otherwise the failure of the following regulation carried out with the instrument).
- Tightening the lower cable will probably have caused the travel limit to shift:



repeat the procedure until the correct position is obtained.

- Turn the key to ON.

CAUTION

INSTRUMENT PANEL WITH SIDE STAND WARNING LIGHT THE "ZERO SEARCH OF THE DISCHARGE VALVE MOTOR" PROCEDURE DOES NOT CANCEL THE PREVIOUS DATA STORAGE, THEREFORE UPON THE KEY ON, THE VALVE MAY MOVE AND THIS MAY CAUSE A CONFLICT WITH THIS ADJUSTMENT; PERFORM THE "SELF-TEACHING OF THE DISCHARGE VALVE" PROCEDURE AS SOON AS POSSIBLE. DO NOT CARRY OUT THIS OPERATION WHEN USING A NON-ORIGINAL EXHAUST SYSTEM WHERE ANY CABLES CONSIDERED NOT NECESSARY HAVE BEEN DISCONNECTED.

INSTRUMENT PANEL WITH a-PRC WARNING LIGHT THE "ZERO SEARCH OF THE DISCHARGE VALVE MOTOR" PROCEDURE ENTAILS RESETTING THE EXISTING MECHANICAL STOPS. AN ERROR FOR STOP SEARCH NOT CARRIED OUT IS THEN INDICATED, WHICH REMAINS UNTIL THE "SELF-TEACHING OF THE DISCHARGE VALVE" PROCEDURE IS PERFORMED. DO NOT CARRY OUT THIS OPERATION WHEN USING A NON-ORIGINAL EXHAUST SYSTEM WHERE ANY CABLES CONSIDERED NOT NECESSARY HAVE BEEN DISCONNECTED.

- Using the diagnostic tool, from the Adjustable parameters screen page, select:

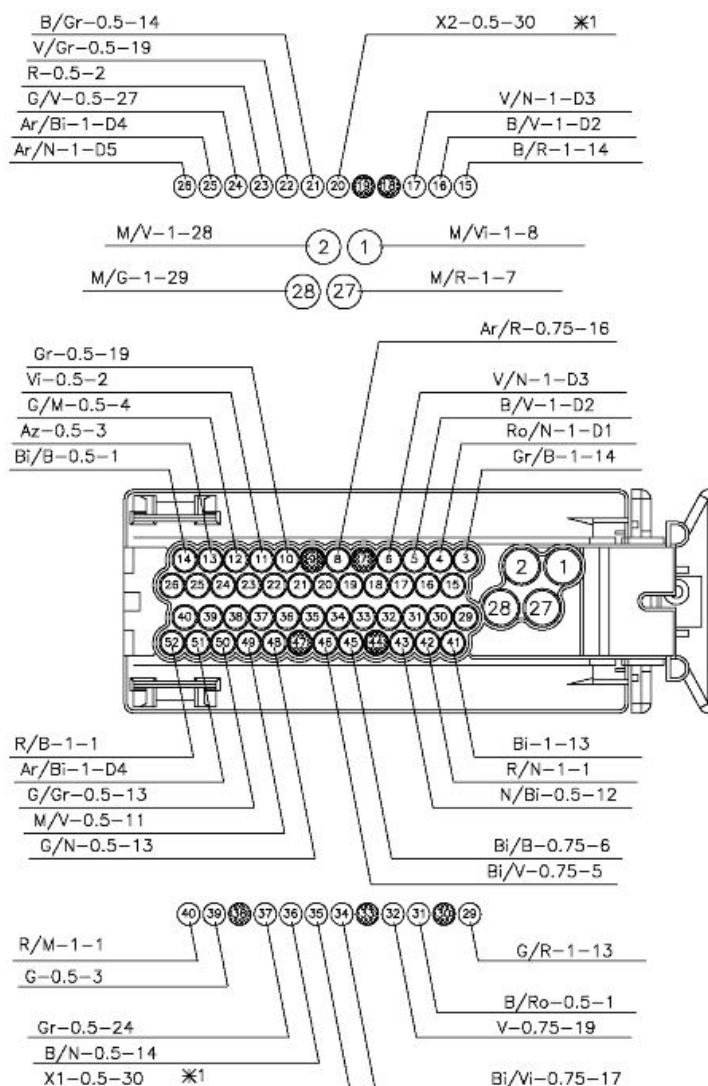
Exhaust valve self-acquisition, which acquires the opening travel limit (4) (valve open) and the closing travel limit (3) (valve closed).

During both normal operation and the self-cleaning cycle, the valve will only move within this range and without reaching the mechanical end stops, to prevent strain to the electric motor.

5 - exhaust fumes flow direction.

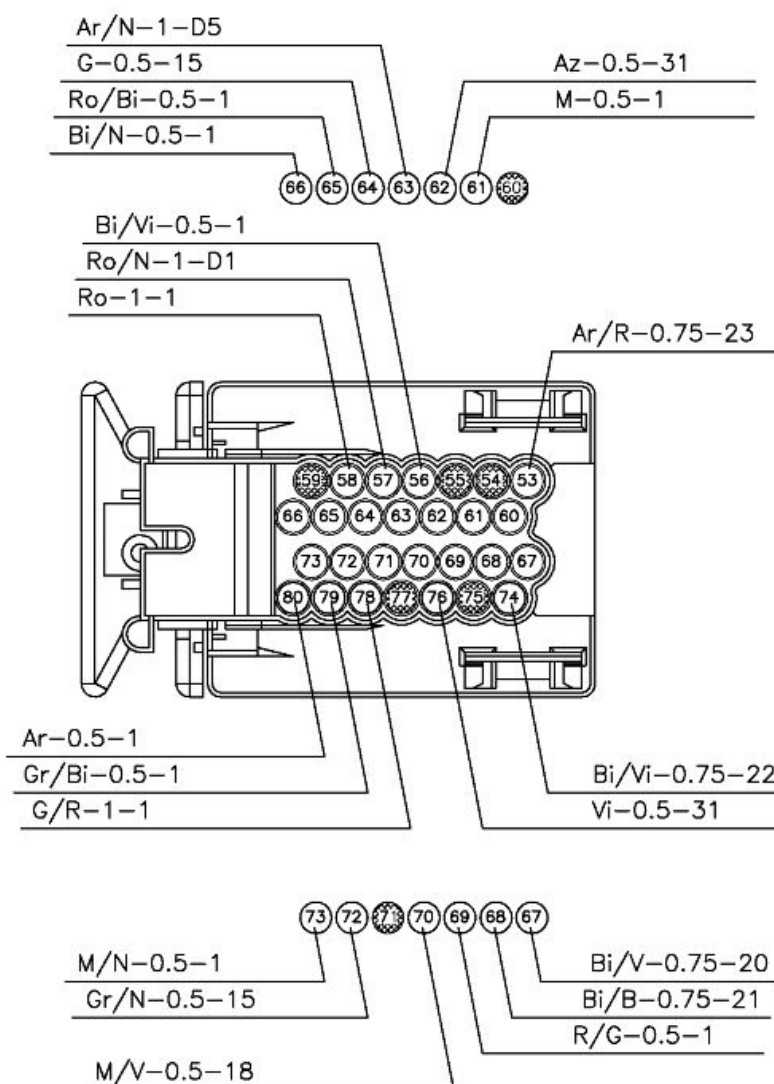
Connectors

ECU

**Engine pinout key:**

- Cylinder 4 coil control output **PIN 1**
- Cylinder 3 coil control output **PIN 2**
- Front throttle motor output (+) **PIN 3**
- Analogue ground connection 2 **PIN 4**
- Power ground connection 1 **PIN 5**
- Analogue ground connection 1 **PIN 6/17**
- Lower cylinder 1 injector control output **PIN 8**
- Lambda sensor input (+) **PIN 10**
- Track D throttle grip input **PIN 11**
- Water temp. sensor input **PIN 12**
- Track B throttle grip input **PIN 13**
- Serial line K for diagnosis **PIN 14**

Front throttle motor output (-) **PIN 15**
Power ground connection 2 **PIN 16**
Engine speed sensor input (-) **PIN 20**
Input for front throttle potentiometer 2 signal **PIN 21**
Lambda sensor input (-) **PIN 22**
Track C throttle grip input **PIN 23**
Rear cylinder intake pressure sensor input **PIN 24**
Reference voltage output + 5 V: tracks A-C, rear throttle and pressure sensor **PIN 25/51**
Reference voltage output + 5V: tracks B-D and front throttle **PIN 26**
Cylinder 2 coil control output **PIN 27**
Cylinder 1 coil control output **PIN 28**
Rear throttle motor output (-) **PIN 29**
STOP lights relay control output **PIN 31**
Lambda heating control output **PIN 32**
Lower cylinder 3 injector control output **PIN 34**
Engine speed sensor input (+) **PIN 35**
Input for front throttle potentiometer 1 signal **PIN 36**
Air temperature sensor input **PIN 37**
Track A throttle grip input **PIN 39**
Key input **PIN 40/42**
Rear throttle motor output (+) **PIN 41**
Secondary air valve control output **PIN 43**
Lower cylinder 4 injector control output **PIN 45**
Lower cylinder 2 injector control output **PIN 46**
Input for rear throttle potentiometer 1 signal **PIN 48**
Front cylinder intake pressure sensor input **PIN 49**
Input for rear throttle potentiometer 2 signal **PIN 50**
Direct power supply to control unit **PIN 52**



Vehicle pinout key:

- Upper cylinder 1 injector control output **PIN 53**
- Clutch sensor input **PIN 56**
- Analogue ground connection 2 **PIN 57**
- "Start engine" switch input **PIN 58**
- Electric fan relay control output **PIN 61**
- Variable geometry control unit control output **PIN 62** (If available)
- Reference voltage output + 5V: tracks B-D and front throttle **PIN 63**
- Neutral input **PIN 64**
- Fall sensor input **PIN 65**
- CAN L line (high speed) **PIN 66**
- Upper cylinder 2 injector control output **PIN 67**
- Upper cylinder 4 injector control output **PIN 68**
- Start-up control output **PIN 69**

Side stand input **PIN 70**

Gear input **PIN 72**

Injection relay control output **PIN 73**

Upper cylinder 3 injector control output **PIN 74**

Variable geometry control unit failure input **PIN 76** (If available)

"engine stop" input **PIN 78**

Vehicle speed input **PIN 79**

CAN H line (high speed) **PIN 80**

Engine - vehicle connector pinout key:

Key **PIN 1A**

Vehicle speed **PIN 2A**

STOP lights relay control output **PIN 3A**

- **PIN 4A**

- **PIN 5A**

- **PIN 6A**

Analogue ground connection 2 **PIN 7A**

Direct power supply to control unit **PIN 8A**

Injection supply **PIN 1B**

CAN H **PIN 2B**

CAN L **PIN 3B**

Key **PIN 4A**

Electric fan relay control **PIN 5B**

Fall sensor **PIN 6B**

Variable geometry power supply **PIN 7B**

Power ground connection 2 **PIN 8B**

Injection power supply **PIN 1C**

Serial line K for diagnosis **PIN 2C**

Clutch sensor **PIN 3C**

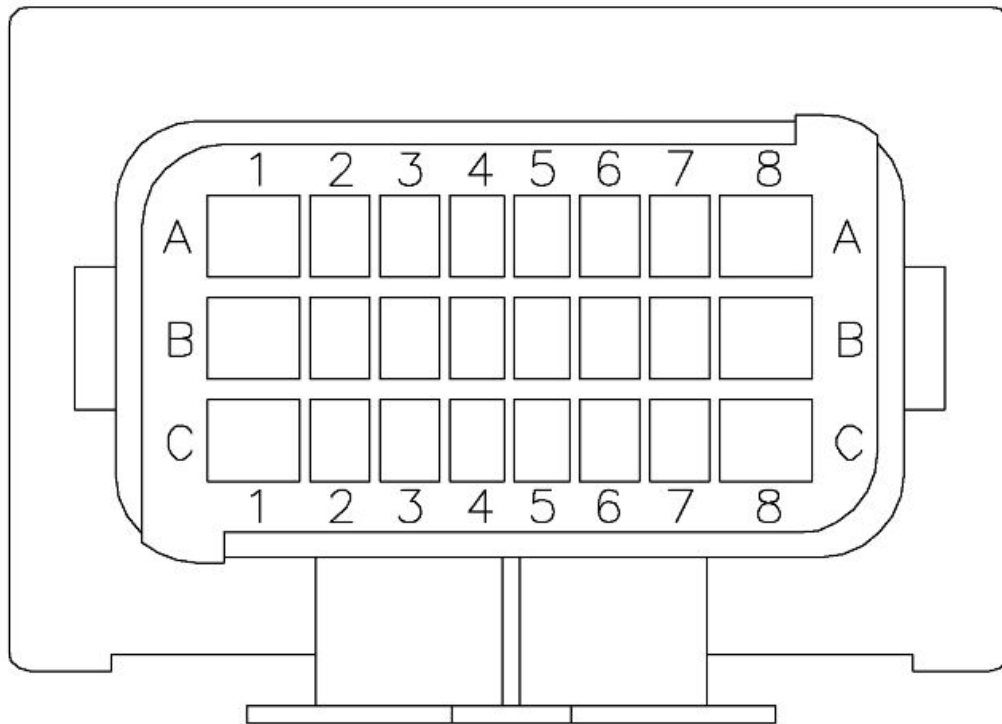
"Start engine" switch **PIN 4C**

Start-up control **PIN 5C**

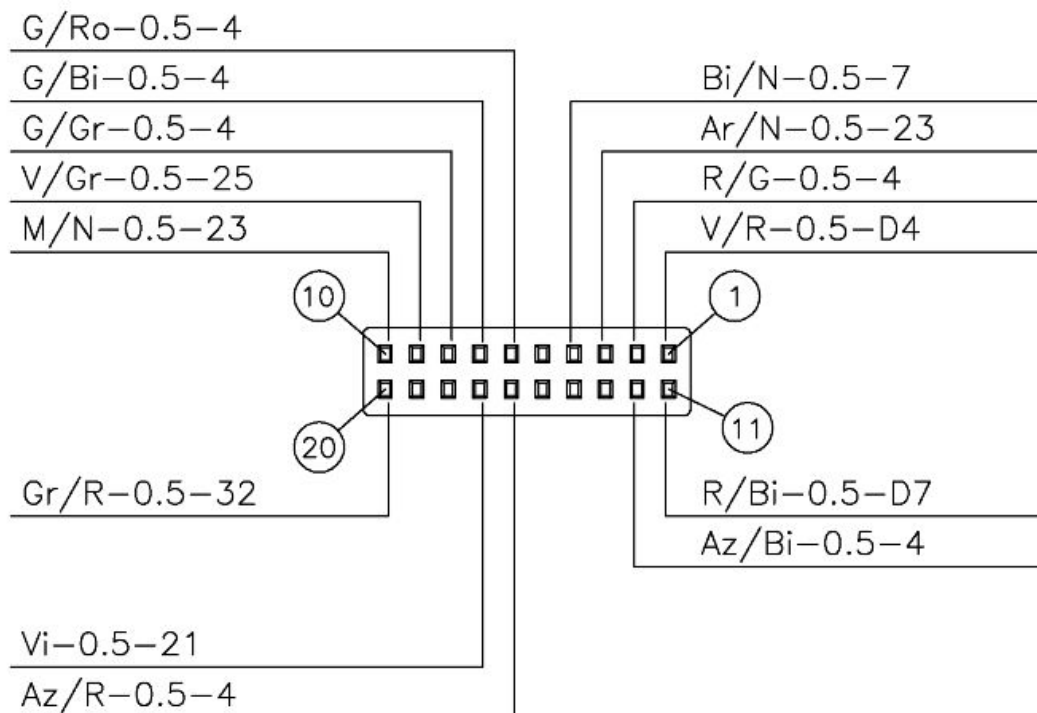
Injection relay **PIN 6C**

Engine stop **PIN 7C**

Power ground connection 2 **PIN 8C**



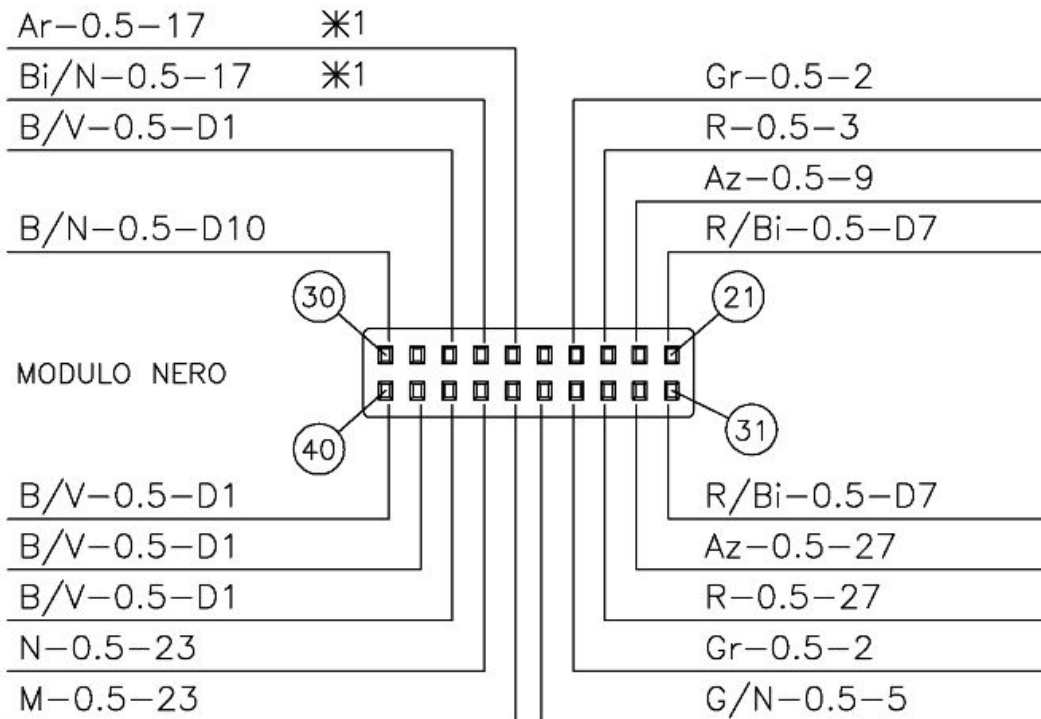
Dashboard



Grey-bodied instrument panel pinout key:

- 1 +Key
- 2 Right turn indicator control
- 3 Exhaust valve potentiometer power supply

- 4 High-beam lights input
- 5 Crono input
- 6 Select 3 (Set)
- 7 Select 2 (Down)
- 8 Select 1 (Up)
- 9 Low fuel sensor
- 10 Exhaust valve potentiometer signal input
- 11+ Battery
- 12 Left turn indicator control
- 13 *
- 14 *
- 15 *
- 16 Indicator reset
- 17 Oil sensor input
- 18 Tuono V4/RSV V4 selection
- 19 *
- 20 K line



Black-bodied instrument panel pinout key:

- 21 +Battery
- 22 Front left turn indicator activation
- 23 Front right turn indicator activation
- 24 Aerial 2

- 25 *
- 26 CAN H
- 27 CAN L
- 28 ABS warning light input (if present)
- 29 *
- 30 Sensors ground connection
- 31 +Battery
- 32 Rear left turn indicator activation
- 33 Rear right turn indicator activation
- 34 Aerial 1
- 35 Low beam light relay activation
- 36 Exhaust valve A control output
- 37 Exhaust valve B control output
- 38 Ground connection
- 39 Ground connection
- 40 Ground connection

Can line

Function

It allows communication between the Marelli injection ECU and the instrument panel.

Operation / operating principle

CAN SYSTEM ADVANTAGES

A CAN (controller Area network) line is a connection among the vehicle several electronic devices, organised as a computer network (Internet). The CAN network has greatly simplified the electrical system layout and consequently, its complexity. With this communication line, needless duplication of several sensors present on the motorbike has been obviated. The sensor signals are shared by the two electronic elaboration units (instrument panel and control unit).

- Cable number reduction: The CAN line travels through a twisted cable to several nodes.
- These nodes can also isolate the errors without causing a system breakdown (FaultsConfination).
- Immunity to interference: the signal travels through two cables and the signal reading is differential (voltage difference between the two signals on both cables). If the two signals are disturbed by an external factor, their difference remains unaltered.
- Communication speed: messages travel at a speed of 250 kbps (data arrive at nodes every 20 ms, i.e. 50 times/second).

CAN PROTOCOL (CONT. NETWORK AREA)

The communication protocol is CSMA/CD (Carrier Sense Multiple Access w/ Collision Detection).

In order to transmit, every node must first check that the BUS (the connection among all devices) is free before attempting to send a message with BUS (Carrier Sense).

If during this period there is no activity on BUS, every node has the same chance to send a message (Multiple Access). If two nodes start transmitting simultaneously, the nodes recognise the "collision" (Collision Detection) and initiate an exchange action based on message priority (messages remain unaltered during exchange and there is no delay for high priority messages).

CAN protocol is based on messages and not on addresses. The message itself is divided into several parts (frames), each of which has a meaning: message priority, data contained, error detection, reception confirmation, etc.

Every network node receives all the messages sent through the BUS (with reception confirmation or error messages) and each node decides if the message is to be processed or rejected. Besides, every node can request information from the other nodes (RTR = Remote Transmit Request).

Level in wiring diagram:

CAN line

Electrical characteristics:

- between PIN 66 and 80 of the control unit: approximately 130 Ohm
- between PIN 26 and 27 of the instrument panel: approximately 120 Ohm

Pin out:

- Line L: white/black cable between Marelli control unit PIN 66 and the black-bodied connector PIN 27 of the instrument panel.
- Line H: orange cable between Marelli control unit PIN 80 and the black-bodied connector PIN 26 of the instrument panel.

CAUTION

BEFORE CARRYING OUT ANY TROUBLESHOOTING, CAREFULLY READ THE GENERAL TROUBLESHOOTING CONCEPTS FOR ELECTRICAL DEVICES AT THE BEGINNING OF THE CHECK AND CONTROL SECTION IN THE ELECTRICAL SYSTEM CHAPTER.

DIAGNOSIS INSTRUMENT: ELECTRICAL ERRORS

CAN line "Mute Node" U1601

- Mute Node.

Error cause

- The injection ECU cannot send CAN signals; it receives signals from the instrument panel: the control unit may need replacing.

Troubleshooting

- Replace the Marelli control unit.

CAN line without signals U1602

- Bus Off.

Error cause

- No communication on CAN line (PIN 66 and/or PIN 80): problem on the whole network (for example, battery cut-off or short circuited or shorted to ground).

Troubleshooting

- check the Marelli control unit VEHICLE connector and the engine-vehicle cable harness connector: if not OK, restore; if OK, check the ground insulation of the two CAN lines from PIN 66 and PIN 80 of the VEHICLE connector: if not OK, restore cable harness; if OK, check the continuity of the two CAN lines from Marelli control unit VEHICLE connector to the instrument panel connector: if not OK, restore the cable harness; if OK, check that the two lines are not shorted to positive testing each of the 3 connectors (Marelli control unit, engine-vehicle cable harness connector and instrument panel connector) with 1 connector disconnected at a time and by setting the key to ON: If not OK, restore; if OK, replace the Marelli control unit.

CAN line towards instrument panel U1701

- no signal.

Error cause

- No signal is received from the instrument panel.

Troubleshooting

- Check the connector of the instrument panel: if not OK, restore; if OK, check the continuity of the two lines from the instrument panel connector to the VEHICLE connector of the Marelli control unit: if not OK, restore the cable harness; if OK, replace the instrument panel.

CAN line towards instrument panel U1702.

- Intermittent signal or communication error.

Error cause

- Probable bad contact in the CAN line.

Troubleshooting

- Check the Vehicle connector pins 66 and 80 and the vehicle-engine cable harness pins B2 and B3. If not OK, restore. If OK, check pins 26 and 27 and the instrument panel connector. If not OK, restore. If OK, check overall operation of the Marelli control unit and instrument panel: replace the affected component if you find any fault

CAN line toward CLF control unit U1712

- Intermittent signal or communication error.

Error cause

- Probable bad contact in the CAN line.

Troubleshooting

- Check the Vehicle connector pins 66 and 80 and the vehicle-engine cable harness pins B2 and B3. If not OK, restore. If OK, check pins 8 and 9 and the CLF control unit connector. If not OK, restore. If OK, check overall operation of the Marelli control unit and CLF control unit: replace the affected component if any fault is detected.

DIAGNOSIS INSTRUMENT: LOGIC ERRORS

CAN line toward CLF control unit U1711

- No signal/Configuration error

Error cause

- With no signal, no signal is received from the CLF control unit.

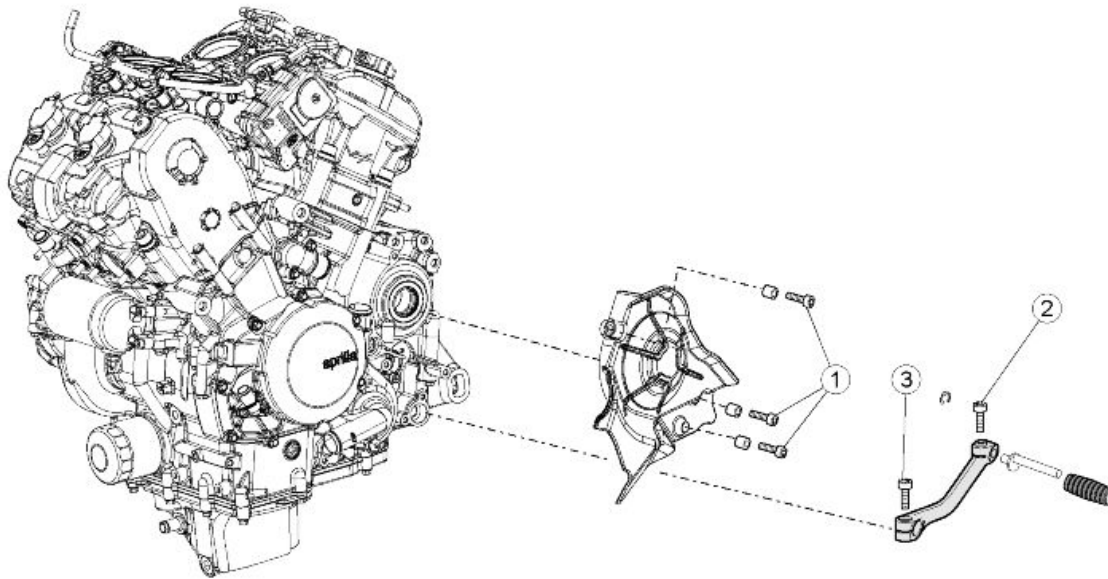
Troubleshooting

- With the diagnosis instrument carry out the specific adjustment that sets "NO PRESENT" to the Aprilia Traction Control status.
-

INDEX OF TOPICS

ENGINE FROM VEHICLE

ENG VE



ENGINE

pos.	Description	Type	Quantity	Torques	Notes
1	Pinion protector casing fixing screws	M6	3	8 Nm (5.9 lbf ft)	-
2	Gearbox lever pin fixing screw	M6	1	10 Nm (7.37 lbf ft)	-
3	Gearbox lever fixing screws	M6	1	10 Nm (7.37 lbf ft)	-

Vehicle preparation

Proceed as follows to remove from the chassis:

- Remove the underfairings, the fairing lug and the radiator cowl.
- Remove the fuel tank and the battery.
- Disconnect and remove the hand grip position sensor.
- Remove the throttle body and the filter box.
- Remove the complete exhaust.
- Remove the lubrication and cooling system radiators.
- Remove the side stand.
- Remove the left hand rider footpeg.

Position the vehicle as described:

- Fasten an appropriately sized belt for the weight of the vehicle to the semi-handlebars and to a hoist.
- Fit the rear and front stands.
- Fit the specific under-sump engine support plate.

Specific tooling

020864Y Engine mounting plate

See also[Fairing mounting panels](#)[Lower cowl](#)

Radiator cover

Fuel tank

Exhaust

[Twistgrip position sensor](#)[Air box](#)[Removing](#)

Side stand

Removing the engine from the vehicle

- Detach the clutch cable.



- Remove the timing sensor.



- Remove the engine oil pressure sensor.



- Remove the rubber cap.
- Unscrew and remove the nut, retrieve the washer and disconnect the starter motor.



- Unscrew and remove the screw, remove the cable grommet and detach the three ground cables.



- Unscrew and remove the nut and retrieve the washer.
- Detach the ground from the chassis.



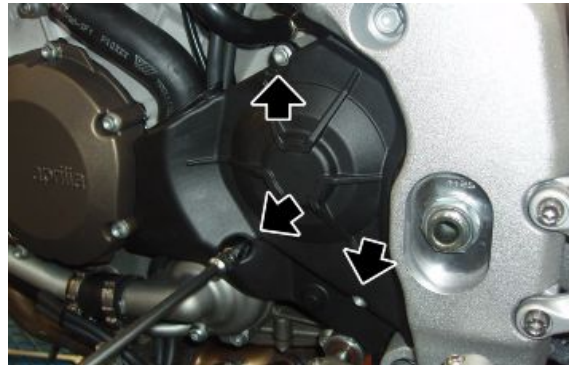
- Working on the right hand side of the vehicle, detach the exhaust valve control unit connector.



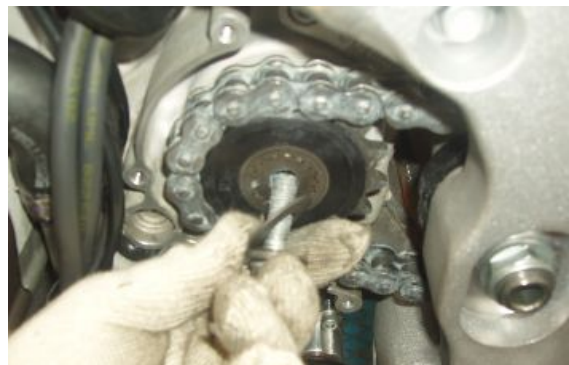
- Disconnect the vehicle cable harness/ engine cable harness connector



- Unscrew and remove the three screws and remove the pinion cover.



- Unscrew and remove the pinion fixing screw and retrieve the two washers.



- Loosen the drive chain adjuster screws.



- Loosen the rear wheel fixing nut.
- Remove the pinion, releasing it from the drive chain.



- Remove the side stand.
- Remove the two fuel breather pipes



- Detach the neutral sensor.



See also

Side stand

-
- Remove the hand grip position sensor from the chassis.



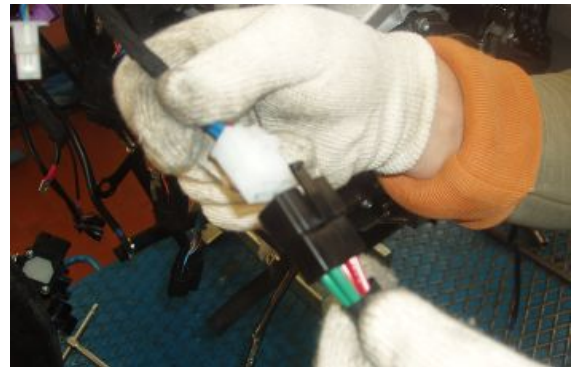
-
- Disconnect the voltage regulator connector.



See also

[Twistgrip position sensor](#)

-
- Disconnect the alternator connector.



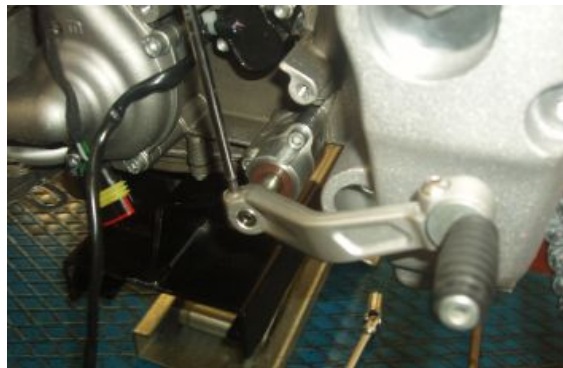
-
- Working from the left hand side of the vehicle, unscrew and remove the screw and retrieve the washer.



- Unscrew and remove the three plate fixing screws and remove the plate.



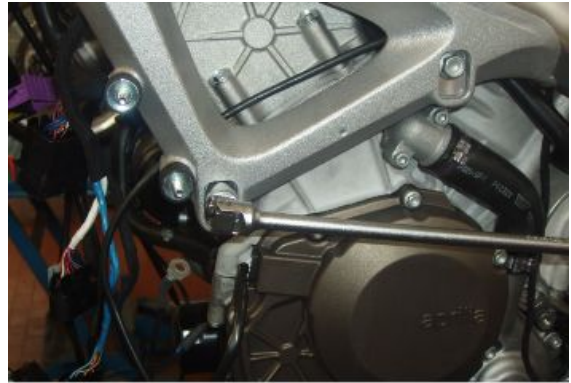
- Loosen the screw and ease off the gear lever.



- Unscrew and remove the subframe fixing screw and retrieve the washer, remove the radiator subframe.



- Working on the left side of the vehicle, undo and remove the two screws.



- Working on the right side of the vehicle, undo and remove the two screws and the washers.
- Also retrieve the shims on the inner side of the frame.



- Unscrew and remove the screw and retrieve the nut.



- Unscrew the upper adjuster screw bushing until it turns no more.



- Working on the right side of the vehicle, unscrew and remove the nut and retrieve the washer.
- Ease off the pin from the left hand side of the vehicle.



- Unscrew the lower adjuster screw bushing.



- Remove the clamps on the saddle mounting.

**CAUTION**

PERFORM THE OPERATIONS BELOW AIDED BY A SECOND OPERATOR.

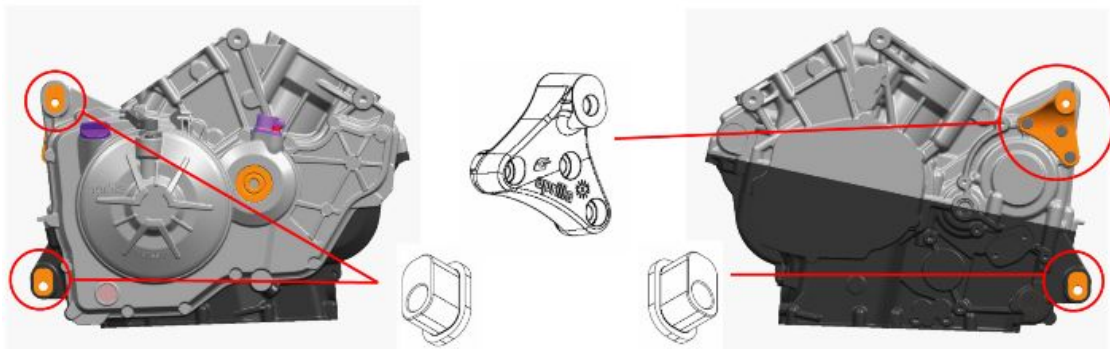
- Lower the engine
- Lift the front part of the vehicle.
- Remove the front stand.
- Release the belts from the hoist, supporting the front part of the vehicle.
- Remove the rear stand.
- Remove the chassis from the engine.

Installing the engine to the vehicle

- Before aligning the engine retainers, fit right and left inserts on the engine, taking the precautions described above, checking that the holes are facing downwards.

CAUTION

THE REAR RIGHT AND REAR LEFT LOWER INSERTS ARE THE SAME.



- Working from the vehicle left side, install the left upper engine attachment, tightening the three screws.



- With the help of a second operator, secure the vehicle chassis with a hoist and onto a front and rear stand and lift the engine to place it in position.

Specific tooling

020864Y Engine mounting plate

Centring the engine on the chassis

CAUTION

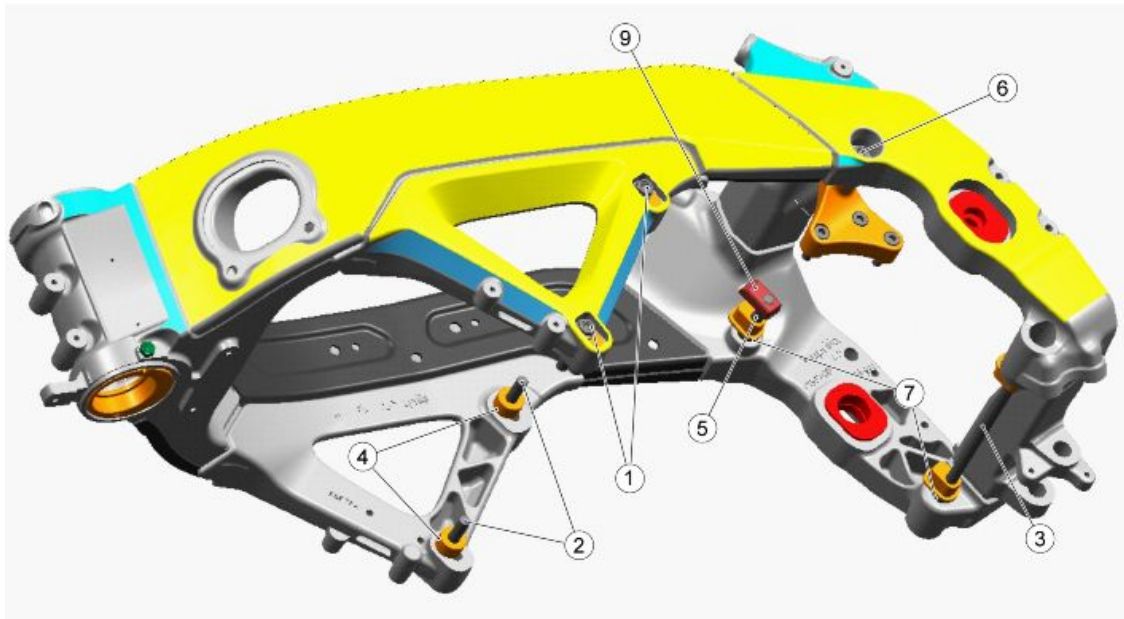
PAY SPECIAL ATTENTION DURING CENTRING PHASE OF THE ENGINE ON THE CHASSIS. OPERATE WITH CAUTION SO AS NOT TO DAMAGE THE SCREWS AND THE CHASSIS INTERNAL AND EXTERNAL SPACERS.

Working on the left side, place and screw without tighten:

- the two front fixing screws (1);
- the engine attachment upper fixing screw (6);
- the lower rear fixing pin (3), so as to centre the engine position.

Working on the right side, place and screw without tighten:

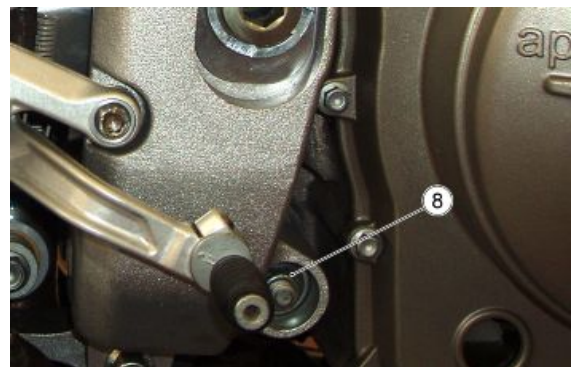
- the two front fixing screws (2) and, from the chassis internal side, the specific spacers (4);
- the upper rear fixing screws (5).



Engine retainer

CAUTION

AFTER ENGINE ALIGNMENT AND CENTRING ON THE CHASSIS, ASSURE THE CORRECT POSITION BEFORE TIGHTENING TO THE PRESCRIBED TORQUE ALL THE SCREWS IN THE ABOVE MENTIONED ORDER.



Working on the left side:

- tighten the two front screws (1) to the prescribed torque.
- Tighten the engine attachment upper fixing screw (6) to the prescribed torque, after placing the corresponding washer.
- Slide the lower rear fixing pin (3);

Working on the right side:

- slide the upper rear fixing screw (5).
- Place and tighten internally the two set pack bushings (7) to the prescribed torque.
- Place again on the left side, the lower rear fixing pin (3).
- Tighten the rear pin fastening nut (8).
- Place again the upper rear fixing screw (5) and tighten the lock nut (9) on the internal side of the chassis to the prescribed torque.
- Tighten the two engine screws (2) to the prescribed torque.

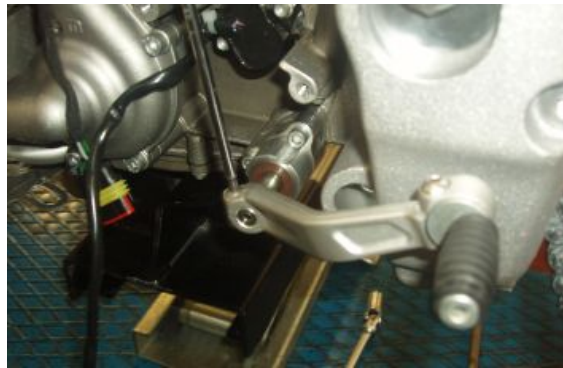
- Refit the clamps on the saddle mounting.



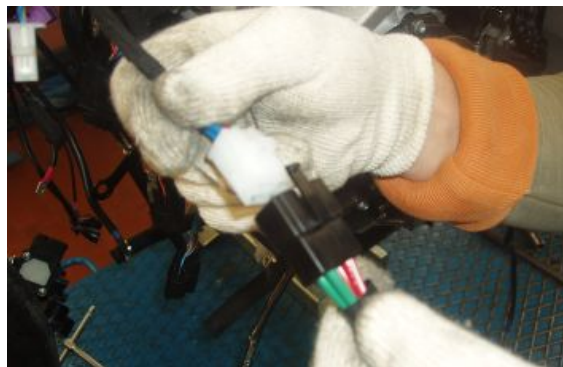
- Place the radiator frame, the washer and tighten the screw, fastening the frame to the engine.



- Place the gear lever and tighten the screw.



- Connect the alternator connector.



- Connect the voltage regulator connector.



- Position and fix the hand grip position sensor to the chassis.

WARNING

BEFORE POSITIONING THE DEMAND SENSOR APPLY SOME LOCTITE 243 ON THE SILENT BLOCKS.



- Connect the neutral sensor.



- Place the two fuel breather pipes.
- Install the side stand.



- Place the pinion and insert the transmission chain in the seat.
- Tighten the rear wheel fixing nut.



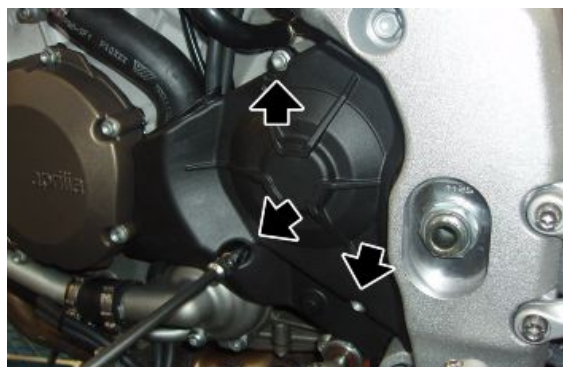
- Adjust the drive chain adjuster screws.



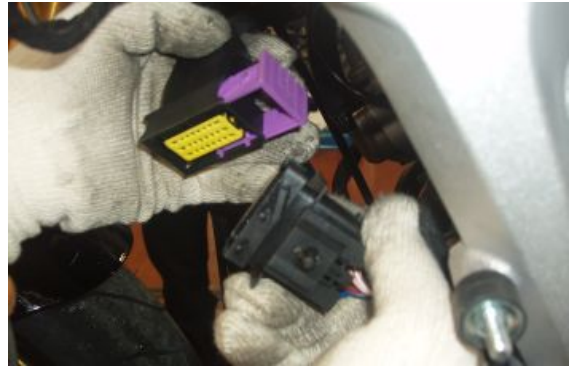
- Place the two washers and tighten the pinion fixing screw.



- Place the pinion cover and tighten the three screws.



- Connect the vehicle cable harness / engine cable harness connector.



- Working on the right side of the vehicle, connect the exhaust valve control unit connector.



- Place the ground on the frame.
- Fit the washer and tighten the nut.



- Place the cable grommet and the three cable leads as shown.
- Tighten the cable grommet fixing screw.



- Connect the starter motor, place the washer and tighten the nut.
- Place the rubber cap.



- Tighten the engine oil pressure sensor.



- Connect the timing sensor.

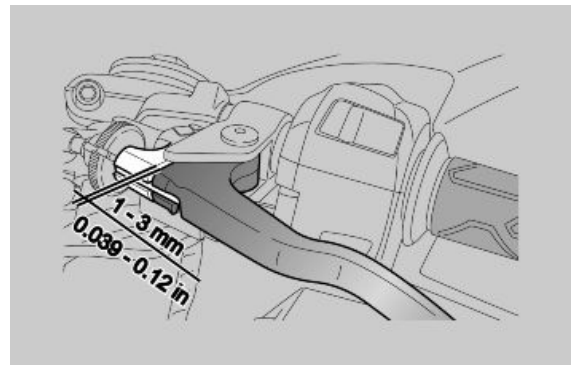


- Connect the clutch cable.





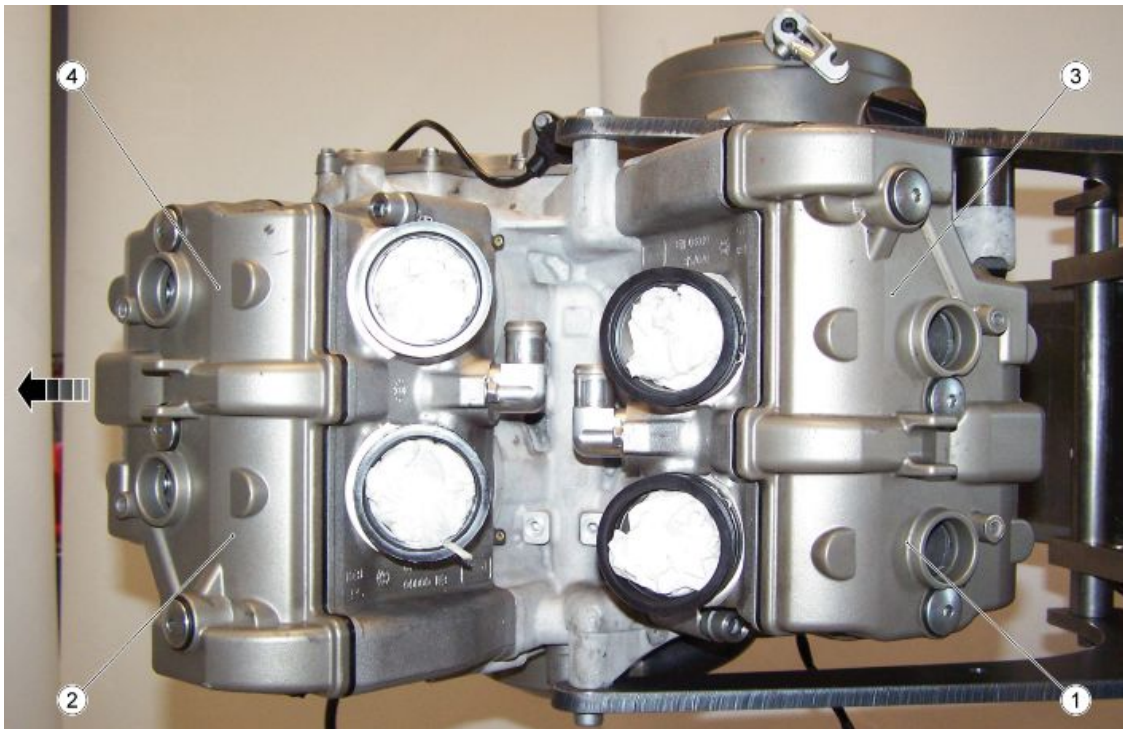
- Check and adjust the clutch lever clearance with the adjuster screw.
- The clutch lever clearance should be between 1-3 mm (0.039 - 0.12 in).



INDEX OF TOPICS

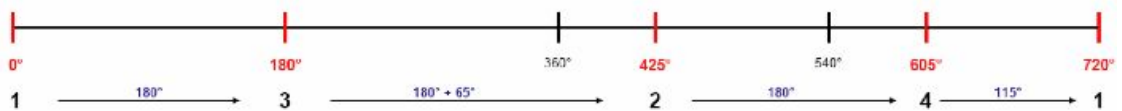
ENGINE

ENG



key:

- 1. rear left cylinder;
- 2. front left cylinder;
- 3. rear right cylinder;
- 4. front right cylinder.



Combustion sequence:

1 - 3 - 2 - 4

Combustion angle:

cyl 1: 0°

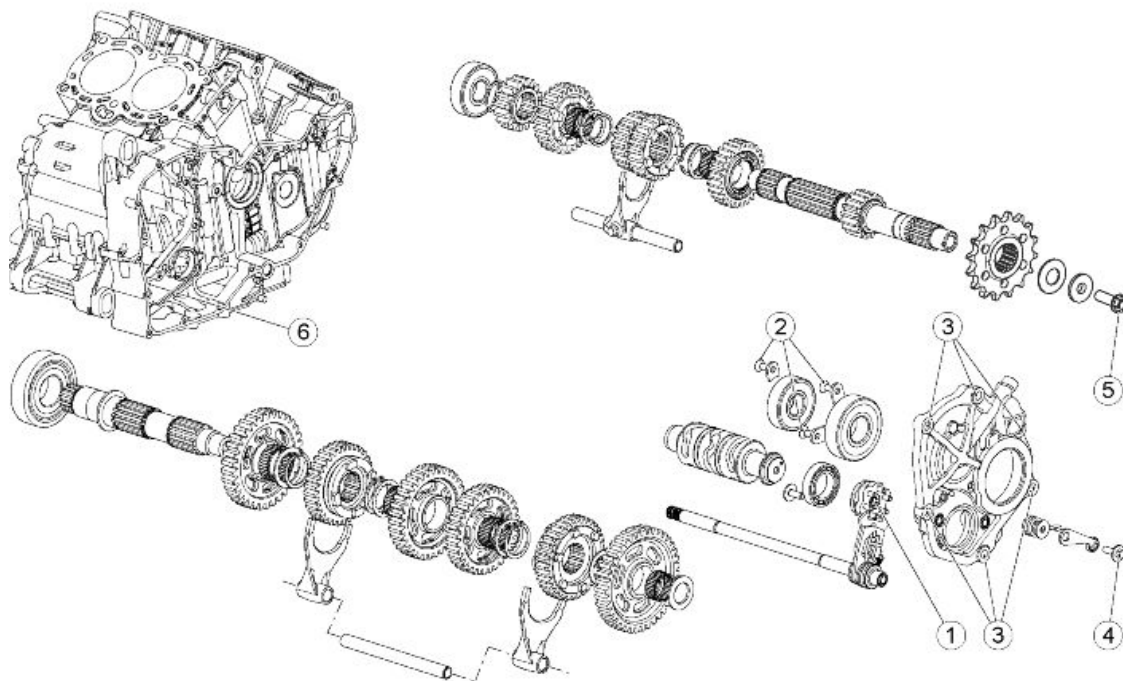
cyl 2: 180°

cyl 3: 425°

cyl 4: 605°

Gearbox

Diagram



GEAR

pos.	Description	Type	Quantity	Torque	Notes
1	Connector drum fastener screw	M6x20	1	10 Nm (7.37 lbf ft)	Loct. 243
2	Bearing retainer plate fixing screw	M6x16	3	10 Nm (7.37 lbf ft)	Loct. 243
3	Flange fixing screws	M8x25	6	25 Nm (18.44 lbf ft)	-
4	Index lever fixing screw	M6	1	10 Nm (7.37 lbf ft)	Loct. 243
5	Pinion retainer	-	1	50 Nm (36.88 lbf ft)	Loct. 243
6	Screw retaining pre-selector on crankcase	-	1	25 Nm (18.44 lbf ft)	Loct. 270
-	Gear indicator fixing screw	M5x15	2	6 Nm (4.42 lbf ft)	-

Removing the gearbox

- Remove the gearbox selector.
- Remove the clutch housing.
- Remove the gear sensor from the flywheel side.

- Remove the Seeger ring.
- Remove the water/oil pump control gear.

**See also**

[Removing the gear selector](#)
[Disassembling the clutch](#)

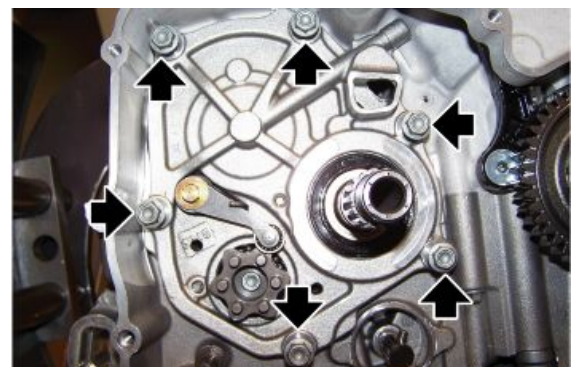
- Remove the water/oil pump control gear driving pin



- Loosen the screw.



- Unscrew and remove the six screws.



- Screw a M10x120 screw in the secondary shaft hole, from the alternator side, to make it easier to extract the gearbox unit.
- Use a rubber mallet to tap on the secondary shaft from the alternator side to detach the gearbox cover from the crankcase.
- Remove the complete gearbox unit.



Gearbox shafts

Disassembling the gearbox

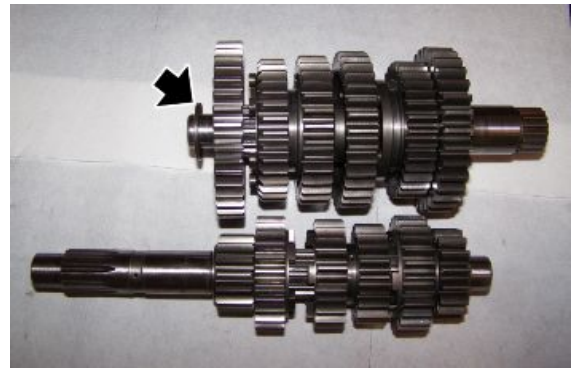
- Position the gear in neutral, checking that when the primary shaft rotates the secondary shaft does not move.
- Remove the gearbox unit.
- Slide off the gearbox primary shaft control rod together with the fork.



- Slide off the gearbox secondary shaft control rod together with the forks.



- Remove both gearbox shafts from the cover.
- Collect the shim washer that is located on the secondary shaft between the shaft and the cover.

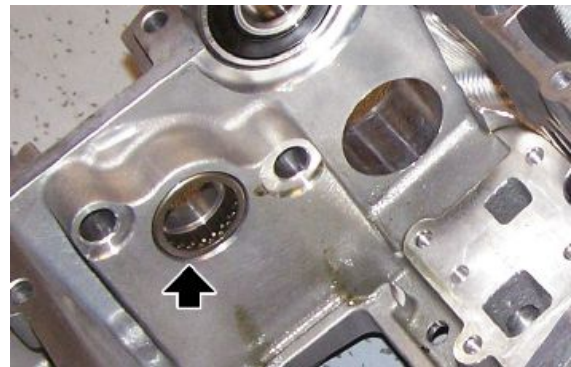


- Unscrew and remove the screw.
- Remove the selector drum.



DESMODROMIC GEARBOX CONTROL ROD DRUM ROLLER CAGE, ALTERNATOR SIDE

- Remove the lower crankcase.
- A suitable extractor must be used to remove the desmodromic gearbox control rod drum roller cage from the alternator side.



- A specific punch is required to install the desmodromic gearbox control rod drum roller cage.
- Lubricate the seat and insert the new roller cage.



Checking the primary shaft

Characteristic

Maximum wear limit for the selection gear grooves

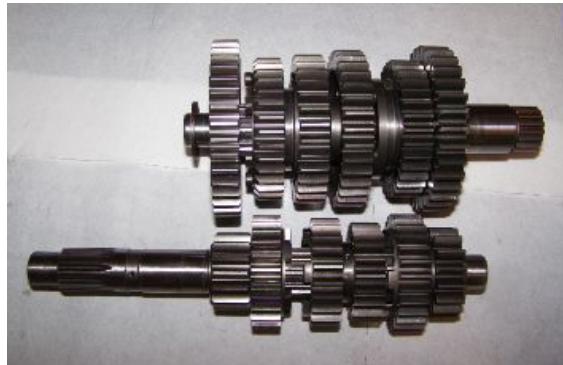
5.3 mm (0.21 in)

Minimum wear limit of the pinion side primary shaft seat

24.97 mm (0.98 in)

Minimum wear limit of the clutch side primary and secondary shaft seat

19.97 mm (0.79 in)



Checking the secondary shaft

Characteristic

Maximum wear limit for the selection gear grooves

5.3 mm (0.21 in)

Minimum wear limit of the pinion side secondary shaft seat

29.97 mm (1.18 in)

Minimum wear limit of the clutch side primary and secondary shaft seat

19.97 mm (0.79 in)

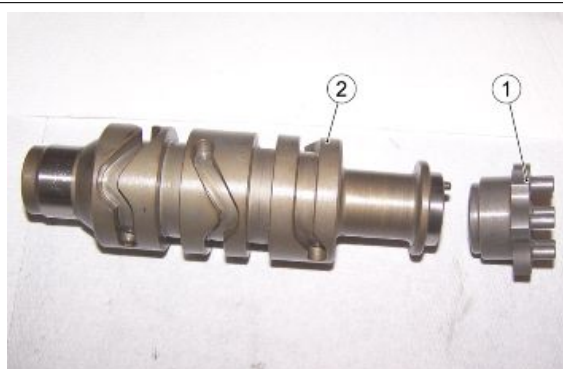


Checking the desmodromic drum

Check gear drum for damage, scratches and wear and replace the desmodromic if necessary.

Check the desmodromic segment (1) for damage and wear and replace it if necessary.

Check the desmodromic bearing (2) for damage and pitting and replace it if necessary.



Characteristic

Maximum selector shaft eccentricity

0.2 mm (0.0079 in)

Checking the forks

The purpose of the springs at the end of the gearbox control rods is to reduce vibration and make it easier to engage the gears.

Characteristic

Maximum selection fork axial clearance

0.5 mm (0.020 in)

Minimum wear limit of the selection fork guide pins

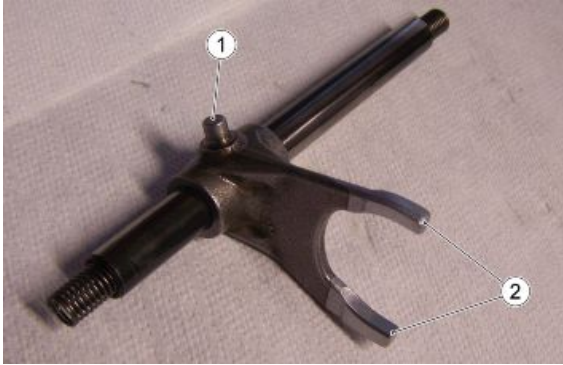
6.8 mm (0.27 in)

Maximum eccentricity of the two fork guide shafts

0.05 mm (0.0020 in)

NOTE

THE FOLLOWING PROCEDURE IS VALID FOR ALL GEARBOX FORKS.

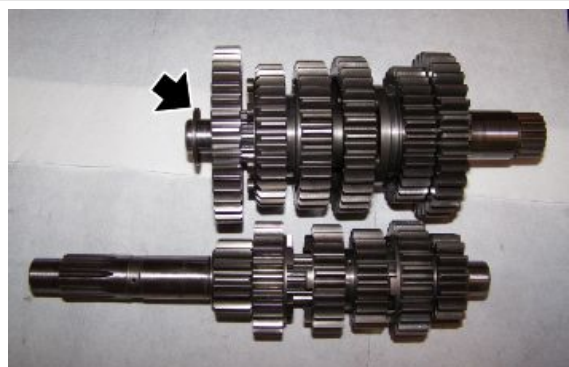
- Check the transmission fork cam roller «1» and the transmission fork tooth «2» for damage, deformation and wear.
 - Replace the transmission fork if necessary.
- 
- Check the transmission fork movement and if it is not regular, replace the transmission forks.

Assembling the gearbox

- Move the gearbox primary and secondary shafts together and fit them into the cover.

NOTE

SECURE THE SHIM WASHER TO THE SECONDARY SHAFT WITH GREASE.



NOTE

MAKE SURE THE SLIDING BUSHING IS PRESENT ON EVERY GEAR CONTROL FORK.

- Grease the bushings.



- Introduce the forks in their respective seats.
- Insert the desmodromic gearbox control rod on the cover.
- Position the selector drum.
- Turn the screw without tightening it.
- Position the fork bushings into the grooves on the desmodromic control rod.



- Insert the fork shafts, making sure the springs are present.





- Position the special tool from the alternator side in order to not ruin the edges of the oil seal.
- Insert the gearbox unit in the crankcase.

Specific tooling

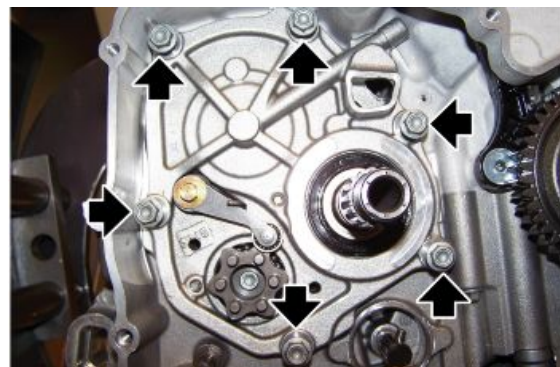
0277308 Guide bushing for secondary gearbox shaft



- Remove the special tool from the alternator side.
- Tighten the six screws that fasten the gearbox unit to the crankcase.

Specific tooling

0277308 Guide bushing for secondary gearbox shaft



- Tighten the selector drum screw.



- Insert the driving pin on the oil pump shaft.
- Install the water/oil pump control gear.
- Insert the Seeger ring.
- Install the gear sensor, making the pin coincide with the slot on the desmotic control rod.



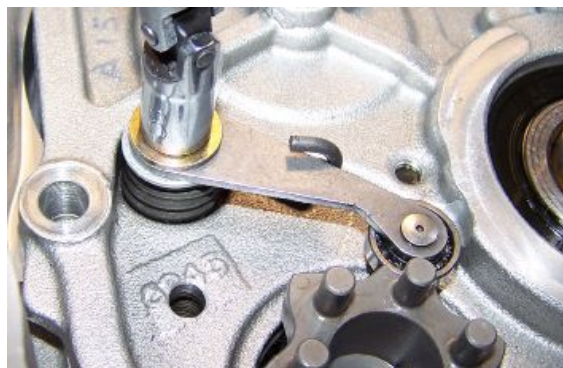
Gear selector

Removing the gear selector

- Drain the engine oil.
- Remove the clutch cover.
- Working from the clutch side, remove the selector control shaft.



- Remove the gear locking pawl and retrieve the washer and the spring.



**GEARBOX CONTROL ROD ROLLER CAGE,
CLUTCH SIDE**

- Remove the lower crankcase.
- The specific tool without an adaptor must be used to remove the gearbox control rod roller cage from the clutch side.

**Specific tooling****020862Y Gearbox control rod roller cage fitting punch**

- Fit the adaptor on the specific tool to insert the roller cage at the controlled depth.
- Lubricate the seat and insert the new roller cage from the clutch side.

**Specific tooling****020862Y Gearbox control rod roller cage fitting punch**

GEARBOX CONTROL ROD OIL SEAL AND ROLLER CAGE, SPACER

- Remove the gearbox control rod spacer.
- Remove the oil seal and the roller cage.
- Install a new gearbox control rod roller cage on the spacer, using the specific tool without an adaptor.

Specific tooling**020862Y Gearbox control rod roller cage fitting punch**

- Position a new oil seal on the spacer with the writing on the edge of the oil seal facing outward.
- Install the oil seal on the spacer using the specific tool without an adaptor.

**Specific tooling****020862Y Gearbox control rod roller cage fitting punch**

Checking the gear selector

Check the stop lever for damage and wear and make sure the ball rotates freely.

If necessary, replace the parts.

Check the gear selector spring for damage and wear.

If necessary, replace the part.



Check the selector shaft and its teeth for damage and wear.

If necessary, replace the part.

Check the lever spring for damage and wear.

If necessary, replace the part.



Reassembling the gear selector

- To refit, lubricate and carry out the removal operations but in reverse order.

Starter motor

Removing the idle gear

- Remove the clutch cover.
- Remove the intermediate gear.



Start-up system check

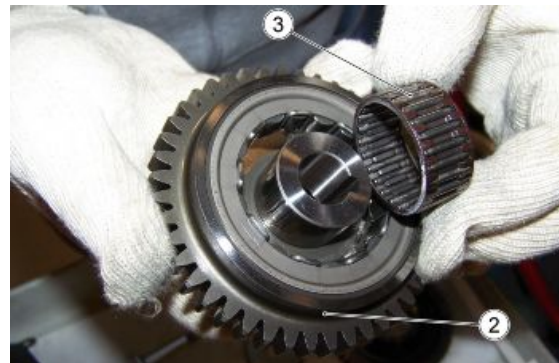


IF THE DUAL STARTER GEAR TOOTHING IS DEFORMED AFTER STARTING, THE STARTER MOTOR TOOTHING MUST BE CHECKED AS WELL.

Check the dual starter gear tooting (1) and the freewheel gear (2) to see if the material is damaged or deformed.



If deformations or broken material are found on the sliding surface, replace the freewheel gear (2).
 Check the freewheel sliding surface (2) for wear.
 Make sure that the woodruff key slot is in perfect condition.



Remove the needle cage (3) and the roller cage (4) from their housings on the freewheel (2) and check the rollers/needles for wear.

Check for wear on the freewheel sliding surface (2).

Fitting the idle gear

NOTE

BE CAREFUL IN MAINTAINING THE CORRECT GEAR RATIO, FOLLOWING THAT INDICATED IN THE TABLE.

MOTOR AND GEAR

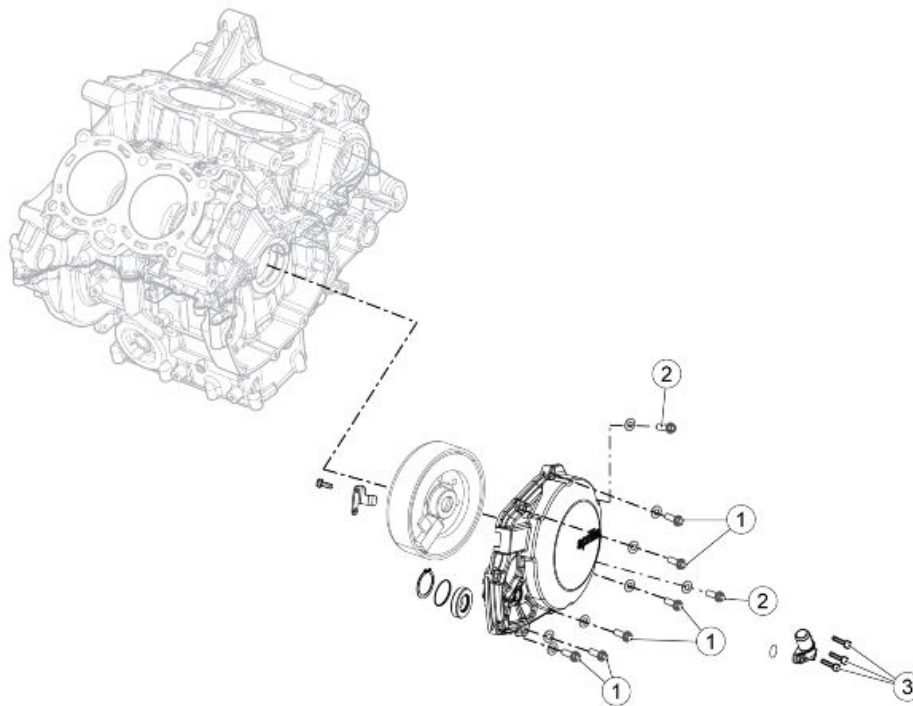
Model	Engine No.	Starter motor	Transmission	Freewheel gear
MY 2009/2010 - "V4" marking	From the beginning of production at No. 7419	Denso	Z=12/64	Z=49

Model	Engine No.	Starter motor	Transmission	Freewheel gear
MY 2010 - "V4" marking	From No. 7420 to No. 8922	Mitsuba	Z=12/64	Z=49
MY 2011 - "V4-A" marking	From the beginning of production at No. 1003	Mitsuba	Z=12/64	Z=49
MY 2011 - "V4-A" marking	From No. 1004 onwards	Denso	Z=12/64	Z=49

- Fit the intermediate gear.
- Fit the clutch cover.



Generator side



ALTERNATOR COVER

pos.	Description	Type	Quantity	Torque	Notes
1	Screws fastening cover onto centre pins	M6x25	6	12 Nm (8.85 lbf ft)	-
2	Cover fastener screws, alternator side	M6x40	2	12 Nm (8.85 lbf ft)	-
3	Blow-by union fastener screws	M5x16	3	7 Nm (5.16 lbf ft)	-
-	Stator fixing screw UNI 5931 CL8.8	M6x25	3	10 Nm (7.37 lbf ft)	Loct. 243
-	Flanged screw	M5x12	1	6 Nm (4.42 lbf ft)	Loct. 243

Removing the flywheel cover

- Release the clamp and detach the Blow-by pipe.
- Unscrew and remove the five screws (1).
- Unscrew and remove the two screws (2).
- Mark the screws (1 - 2) that have different lengths.
- Remove the cover together with the stator and retrieve the two centring dowels.



Magneto flywheel removal

THERE ARE TWO DIFFERENT TYPES OF FLYWHEEL, MITSUBISHI OR KOKUSAN, IN THIS ENGINE. THE TWO FLYWHEELS CANNOT BE INTERCHANGED AS WELL AS THE TOOLS USED FOR THEIR LOCKING AND REMOVAL.

TOOLS FOR KOKUSAN FLYWHEEL:

- Flywheel extractor cod. 020913Y
- Flywheel lock cod. 020914Y

TOOLS FOR MITSUBISHI FLYWHEEL

- Flywheel extractor cod. 020847Y
- Flywheel lock cod. 020848Y

FIND BELOW THE REMOVING AND REFITTING PROCEDURE OF THE MITSUBISHI FLYWHEEL, THE SAME PROCEDURE (EXCEPT FOR TOOLS) IS VALID ALSO FOR KOKUSAN FLYWHEEL.

See also

[Removing the flywheel cover](#)



- Remove the flywheel cover.
- Block flywheel rotation using the specific tool.
- Unscrew and remove the screw.

Specific tooling**020848Y Flywheel retainer (Mitsubishi)****020914Y Flywheel retainer**

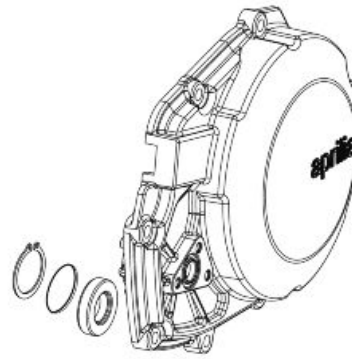
- Remove the tool for blocking flywheel rotation.
- Insert a TCEI M10x20 screw into the crankshaft hole, which will act as a mounting base for flywheel extraction.
- Remove the flywheel using the specific extractor.
- Collect the TCEI M10x20 screw.

**Specific tooling****020847Y Flywheel extractor (Mitsubishi)****020913Y Flywheel extractor (Kokusan)****See also**[Removing the flywheel cover](#)**Inspecting the cover components**

- Unscrew and remove the three Blow-by system fitting screws.
- Remove the Blow-by system fitting.
- Replace the O-ring with a new one of the same type



- Remove the flywheel cover.
- Remove the circlip, thrust washer and inner sealing ring or replace if they are spoiled or in case of oil leaks.



See also

[Removing the flywheel cover](#)

Installing the flywheel

- Position the flywheel on the crankshaft.
- Block flywheel rotation using the specific tool.
- Tighten the screw.

Specific tooling

020848Y Flywheel retainer (Mitsubishi)

020914Y Flywheel retainer



Flywheel cover installation

- Insert the centring dowels in the cover.
- Apply a layer of sealing paste along the external edge of the cover.
- Insert the cover together with the stator.

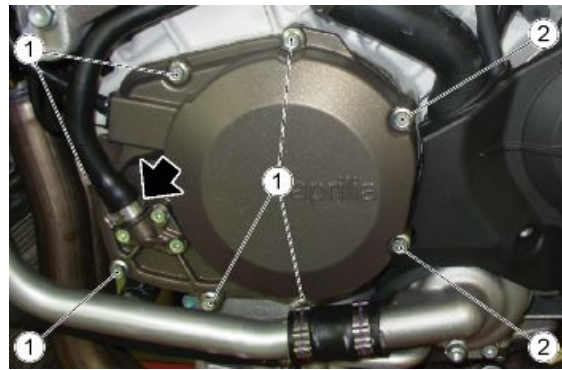
Recommended products

Three bond Sealing paste

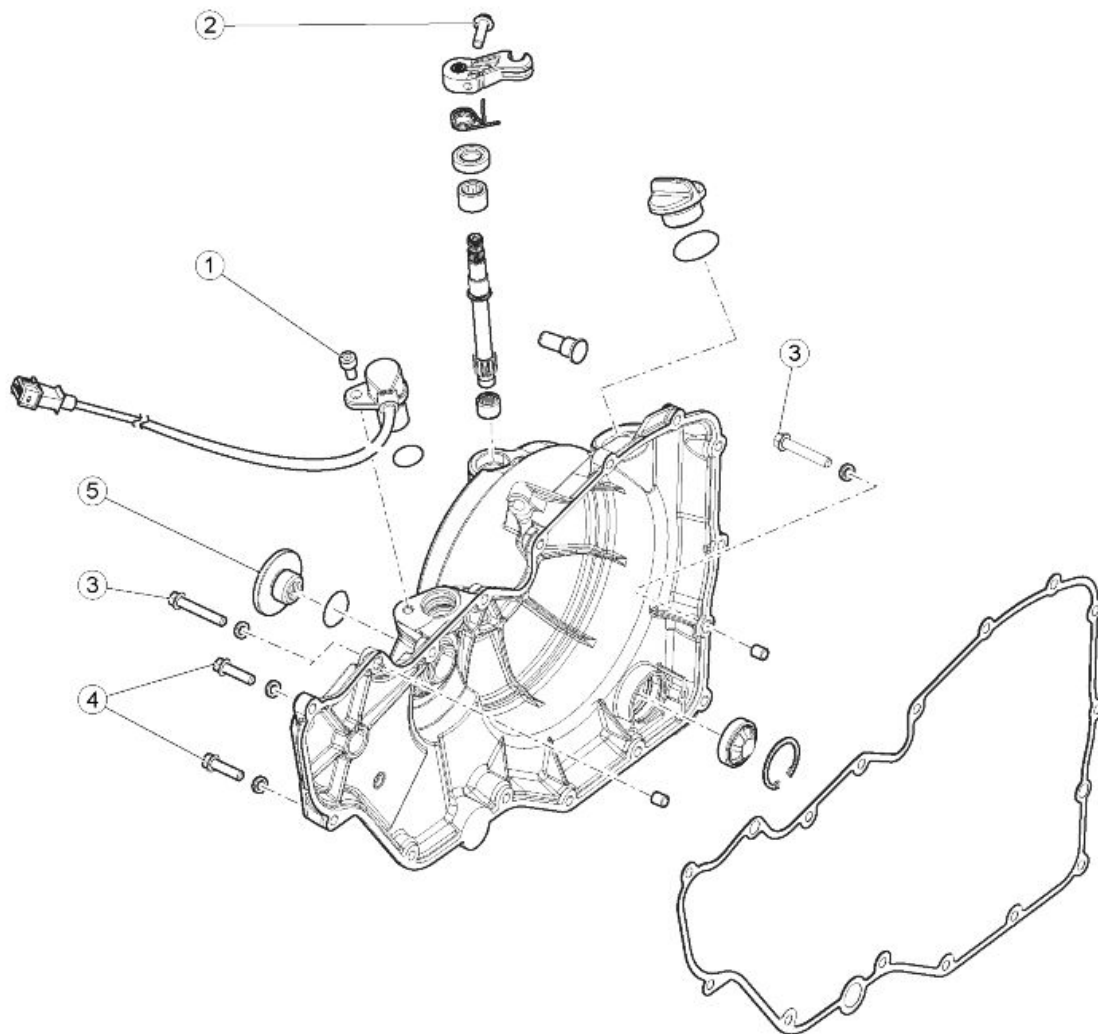
-



- Turn the five screws (1) and the two screws (2).
- Tighten the screws working in stages and diagonally.
- Insert the Blow-by system pipe and fasten it with a new clamp.



Clutch side



CLUTCH COVER

pos.	Description	Type	Quantity	Torque	Notes
1	Engine speed sensor fixing screw	-	1	8 Nm (5.9 lbf ft)	-
2	TE flanged screw	M6x20	1	12 Nm (8.85 lbf ft)	-
3	Flanged TE screws	M6x35	2	12 Nm (8.85 lbf ft)	-
4	Flanged TE screws	M6x22	16	12 Nm (8.85 lbf ft)	-

pos.	Description	Type	Quantity	Torque	Notes
5	Engine timing inspection cap	-	1	25 Nm (18.44 lbf ft)	-

Removing the clutch cover

- Drain the engine oil.
- Unscrew and remove the sixteen perimeter fixing screws and retrieve the washers

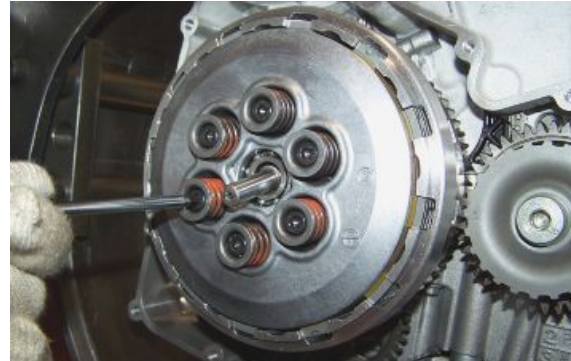


- Remove the clutch casing, retrieving the gasket, the two locator pins and the starter motor transmission gear.

Disassembling the clutch

- Unscrew and remove the tone wheel fixing screw.
- Remove the tone wheel.

- Remove the clutch cover.
- Unscrew and remove the six screws by loosening them 1/4 of a turn at a time; operate in stages and diagonally, and retrieve the washers and the clutch springs.



- Remove the thrust plate and the complete control rod.



- Remove the discs.

See also

[Removing the](#)

clutch cover

- Block clutch bell rotation using the specific tools.
- Unscrew and remove the clutch bell fixing nut.

Specific tooling**020849Y Clutch retainer**

- Remove the slipper unit.



- Remove the clutch hub.



- Remove the clutch hub cam tower.



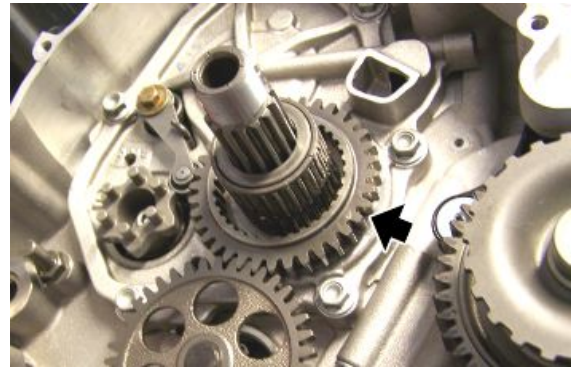
- Collect the shim washer.



- Collect the clutch housing.



- Remove the clutch gear that controls the oil/water pumps



- Remove the needle cage.



- Remove the spacer.



- Remove the thrust bearing.



Checking the clutch plates

Characteristic

Maximum clutch plate deformation (in comparison to a flat surface)

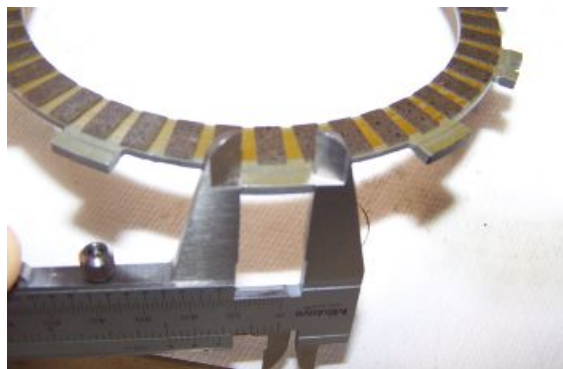
0.15 mm (0.0059 in)

Minimum wear limit of the clutch plate sliding teeth

13.5 mm (0.53 in)

Minimum wear limit of the complete clutch pack thickness (friction discs + steel discs)

47.6 mm (1.87 in)



Checking the clutch housing

Check the clutch bell for damage and wear that may result in clutch irregular operation. If necessary, replace the bell.

Check the riveted joint between the clutch housing and the primary drive sprocket for correct sealing and evenness.

Check the primary driven gear for damage and wear and, if necessary, replace the primary driven gear and the clutch bell all together.

Make sure there is not excessive noise during operation; if necessary, replace the primary drive gear and the clutch bell all together.



Checking the pusher plate

Check the thrust plate and the bearing for damage and wear. If necessary, replace the parts.

Characteristic

Maximum deformation permitted on the thrust plate compression surface

0.15 mm (0.0059 in)

Maximum depth of the thrust plate

27.3 mm (1.07 in)



Checking the clutch hub

Check the clutch hub for damage and wear that may result in clutch irregular operation. If necessary, replace the hub.



Checking the springs

NOTE

THE FOLLOWING PROCEDURE IS VALID FOR ALL CLUTCH SPRINGS.

- Check the springs for damage and, if necessary, replace them all together.
- Measure the clutch spring length when unloaded; if necessary, replace the springs all together.

**Characteristic**

Minimum wear limit in the release position of the ORANGE individual clutch springs

46.8 mm (1.84 in)

Assembling the clutch

- Insert the thrust bearing with the collar facing the gearbox



- Insert the spacer.



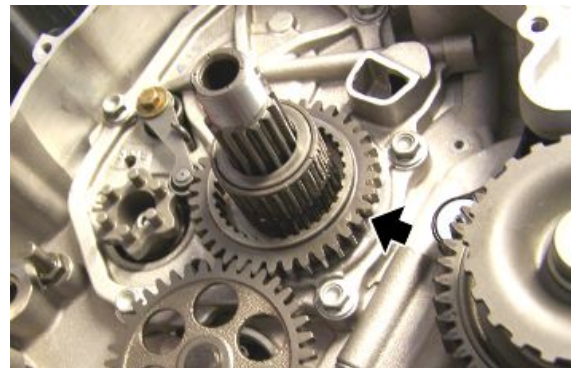
- Fit the needle cage.



- Install the clutch gear, making it mesh with the oil/water pump control gear



TURN THE CLUTCH GEAR COLLAR TOWARD THE CLUTCH BELL.



- Insert the clutch bell, making it engage with the engine pinion



- Fit the shim washer.



- Install the clutch hub cam tower.



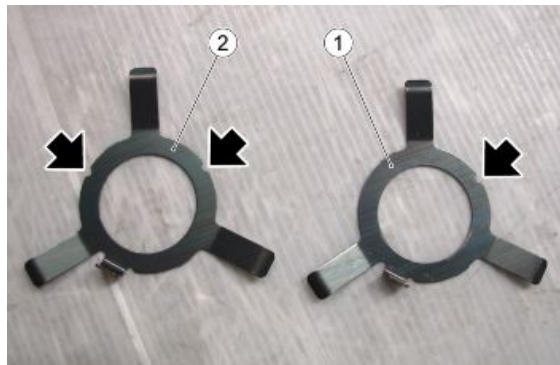
- Position the clutch hub.



HOUSE THE THREE CLUTCH HUB CAMS IN THE SPECIFIC CLUTCH HUB CAM TOWER INCLINES.



- The slipper springs are distinguishable by the cleats. In the 0.8mm spring (1) there is only one notch, while in the 0.9mm spring (2) there are two notches.



SLIPPER SPRINGS

First assembly solution

Specific assistance

Model - Engine No.	Spring No. - Thickness	Washer - Thickness	Spring No. - Thickness	Washer - Thickness
My2009/2010 - All engines	3 - 0.8 mm	NO	3 - 0.8 mm	NO
My2011 - up to No. 3637	3 - 0.8 mm	NO	Alternatively 2 - 0.9 mm	Alternatively YES - 0.9 mm
My2011 - from No. 3638	2 - 0.9 mm	YES - 0.9 mm	2 - 0.9 mm	YES - 0.9 mm

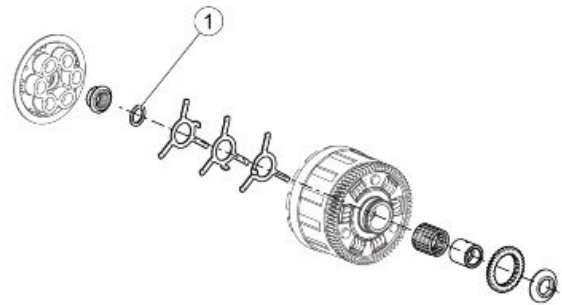
CAUTION

ONCE THE SPRINGS HAVE BEEN RECEIVED BY THE SPARE PARTS, VERIFY THE THICKNESS TO CHOOSE THE RIGHT COMBINATION AS IN THE TABLE

- Fit the three slipper unit clips, offsetting them by 120°.
- Install the slipper unit correctly.



- Where specified in the table, insert the washer (1)



- Block clutch bell rotation using the specific tool.
- Tighten the clutch bell fixing nut.

Specific tooling

020849Y Clutch retainer



- Insert the disc with friction material and the black tooth into the bell.



- Insert one of the metal discs into the bell.



- Insert the flat washer.
- Insert the belleville spring with the concave side facing outward.



- Insert the disc covered with the friction material into the bell.



- Continue inserting, alternating a metal disc with one with friction material, finishing with a friction material disc with a black tooth.



- Place the control rod together with the thrust bearing and the shim washer.
- Place the thrust plate.

**CAUTION**

IN THE EVENT OF AN ORANGE SPRING, IF YOU WANT TO LIGHTEN THE LOAD ON THE CLUTCH LEVER, INSERT THE SHIMMING WASHER IF NOT ALREADY PRESENT. IN THE EVENT OF A BLUE SPRING, THE SHIMMING WASHER MUST NOT BE INSERTED. THE SOLUTIONS ORANGE SPRING + SHIMMING WASHER AND BLUE WASHER ARE EQUAL AND CANNOT BE INTERCHANGED.

USE THE SAME SOLUTION FOR ALL THE STUD BOLTS.

ORANGE SPRING

CAUTION



PAY ATTENTION WHEN REFITTING, RESPECT THE SEQUENCE OF SCREW, CAP, LINING AND SPRING.

- Fit the clutch springs (4).
- Insert the spring holder cap (2) and the shimming washers (3) onto the screws (1).



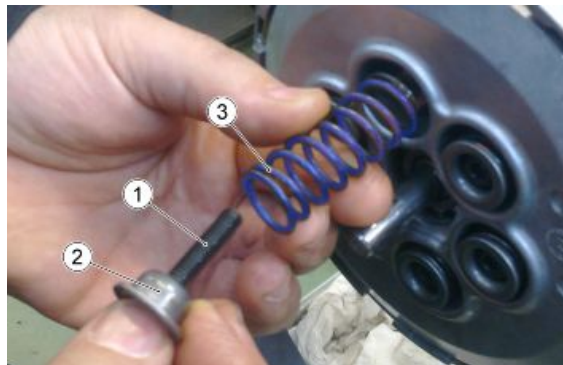
BLUE SPRING

CAUTION



PAY ATTENTION WHEN REFITTING, RESPECT THE SEQUENCE OF SCREW, CAP AND SPRING.

- Fit the clutch springs (3).
- Insert the spring holder cap (2) onto the screws (1).



- Tighten the six screws operating in stages and diagonally.



Installing the clutch cover

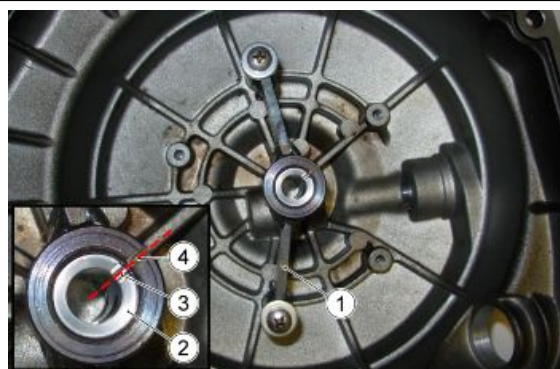
REMOVING THE CLUTCH CONTROL PIN BUSHING

- Before carrying out the removal of the bushing, it is necessary to thread the inside to allow the extractor to tighten sufficiently.



INSTALLING THE CLUTCH CONTROL PIN BUSHING

- Before carrying out the installation of the bushing, it is necessary to warm up the cover.
- Position the guide (1) to insert the bushing (2) as indicated in the figure.
- Insert the bushing so that the processing notch (3) is aligned with the notch on the guide (4).



Specific tooling

020926Y Tool for fitting the clutch control bushing

- Then insert the tool to push the bushing into the seat until it stops.



NOTE

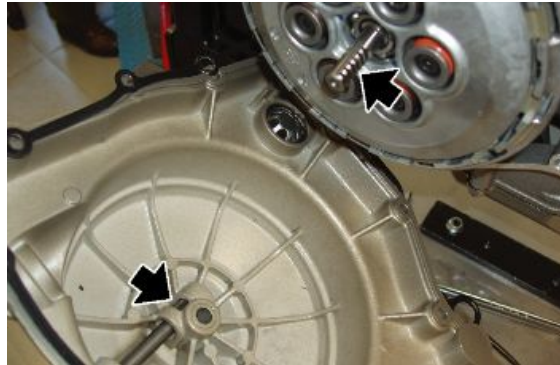
IN THE EVENT OF SHAFT OR OIL SEAL REPLACEMENT, REFER TO THE TABLE AND ALWAYS VERIFY THE CORRECT SIZING.

CLUTCH COVER AND COMPONENTS

Model	Engine No.	Clutch cover	Shaft	Oil seal
MY 2009/2010	Up to No. 2743	Seat Diam. 20 mm (0.79 in)	Diam. 10 mm (0.39)	Diam. 10x20 mm (0.39x0.79 in)

Model	Engine No.	Clutch cover	Shaft	Oil seal
MY 2009/2010	From No. 2744 onwards	Seat Diam. 20 mm (0.79 in)	Ø 12 mm (0.47 in)	Diam. 12x20 mm (0.47x0.79 in)
MY 2011 - "V4" marking	From No. 8001 to No. 8588	Seat Diam. 20 mm (0.79 in)	Ø 12 mm (0.47 in)	Diam. 12x20 mm (0.47x0.79 in)
MY 2011 - "V4-A" marking	From No. 1159 to No. 1456	Seat Diam. 20 mm (0.79 in)	Ø 12 mm (0.47 in)	Diam. 12x20 mm (0.47x0.79 in)
MY 2011 - "V4-A" marking	From No. 1456 onwards	Seat Diam. 22 mm (0.87 in)	Ø 12 mm (0.47 in)	Diam. 12x20 mm (0.47x0.79 in)

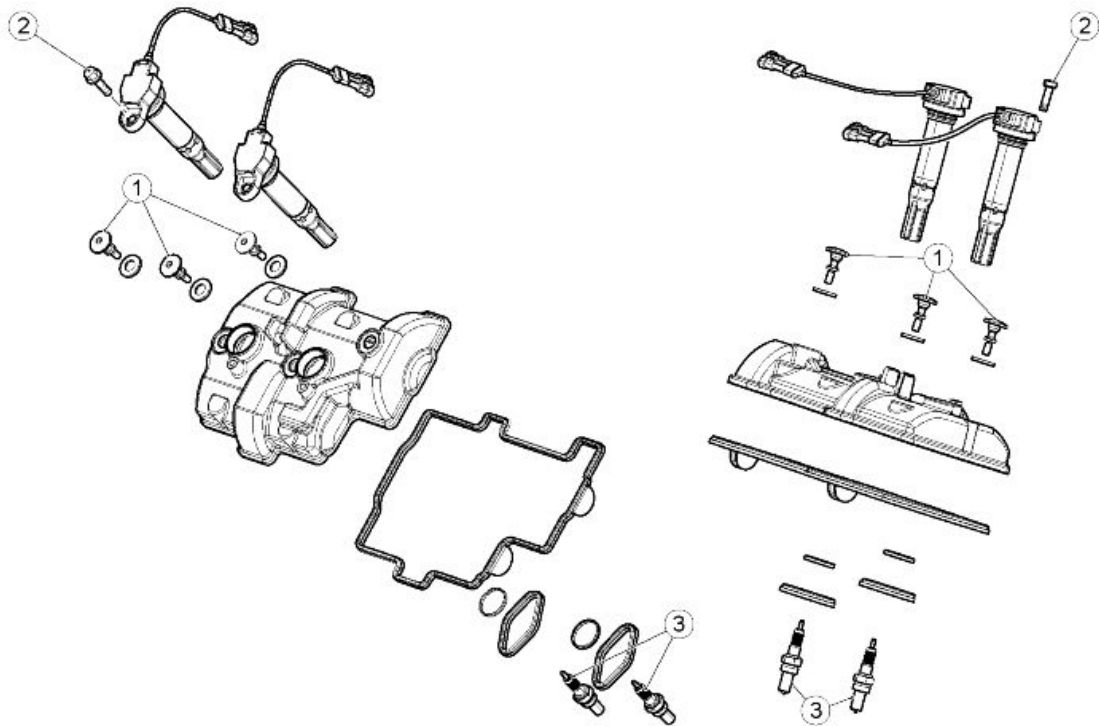
- Position the starting transmission gear on the crankcase.
- Position the gasket and the two dowel pins in the clutch cover.
- Insert the clutch cover, making sure to have correctly engaged the clutch control lever and the rack shaft.



- Screw the sixteen perimeter fixing screws with the washers.
- Tighten the screws working in stages and diagonally.
- Add engine oil up to the correct level.

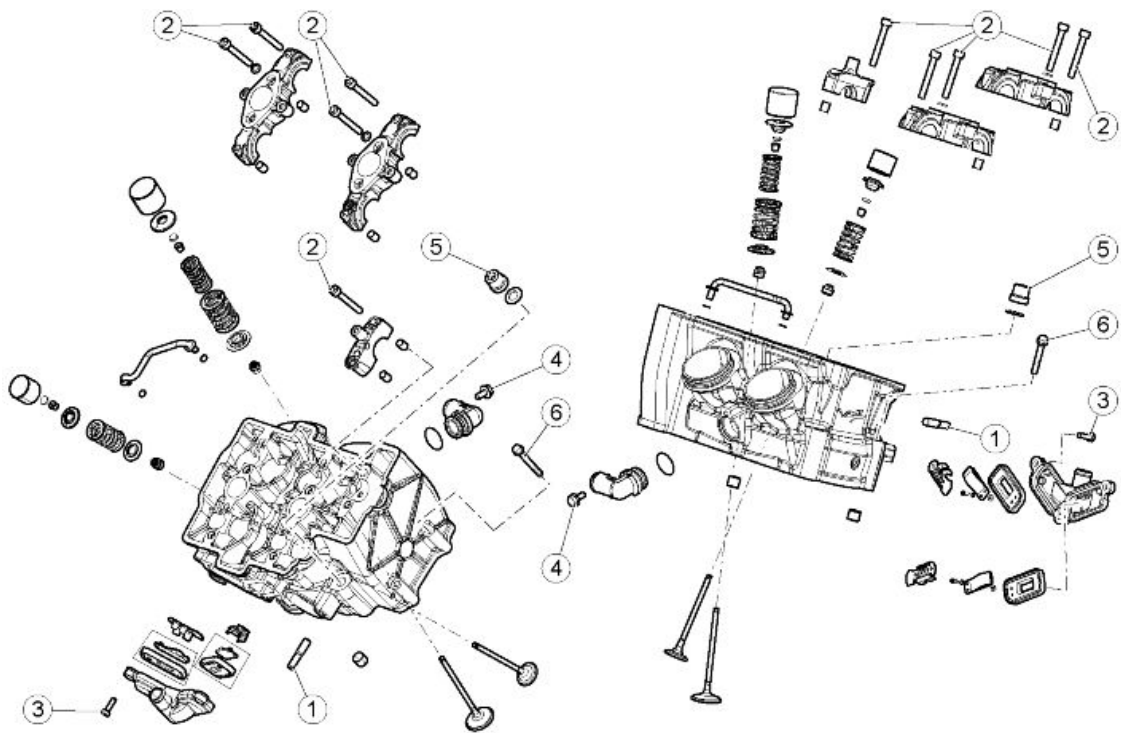


Heads



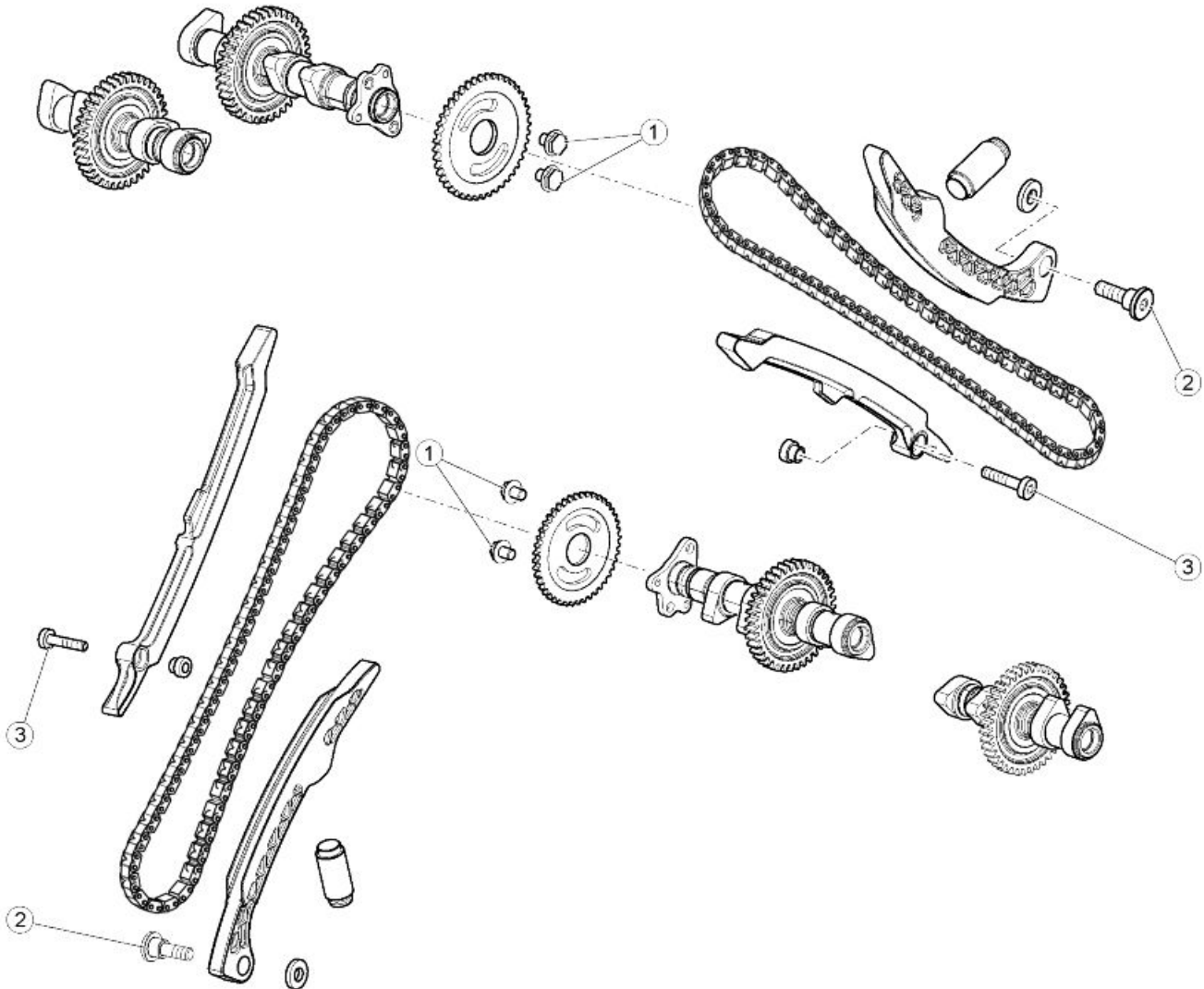
VALVE COVER

pos.	Description	Type	Quantity	Torque	Notes
1	Head cover fixing screws	-	6	10 Nm (7.37 lbf ft)	-
2	Coil fixing screws	-	4	8 Nm (5.9 lbf ft)	Loct. 243
3	Spark plugs	-	4	12 Nm (8.85 lbf ft)	-



HEADS

pos.	Description	Type	Quantity	Torque	Notes
1	Exhaust stud bolts	-	8	10 Nm (7.37 lbf ft)	-
2	Camshaft cam tower fixing screws	M6x45	20	12 Nm (8.85 lbf ft)	-
3	Reed valve cover fixing screws	-	6	6 Nm (4.42 lbf ft)	-
4	Water outlet union fixing screw	-	2	12 Nm (8.85 lbf ft)	Loct. 243
5	Flanged head nut	-	12	30 + 55 Nm (22.13 + 40.56 lbf ft)	Molykote spray on thread and under head
6	Head fastener screw, chain side	M6x55	4	12 Nm (8.85 lbf ft)	-



TIMING SYSTEM

pos.	Description	Type	Quantity	Torque	Notes
1	Screws fastening the timing system gear on the intake shaft	M8	4	30 Nm (22.13 lbf ft)	Loct. 243
2	Skid fastener screws	M8	2	20 Nm (14.75 lbf ft)	Loct. 243
3	Skid fastener screws	M6x18	2	10 Nm (7.37 lbf ft)	Loct. 243

Head cover removal

- Unscrew and remove the three screws with rubber washers.
- Remove the head cover together with the sealing gasket.



When refitting: spread a layer of sealing paste on the external corners of the head



DURING REFITTING REPLACE THE GASKET WITH A NEW ONE OF THE SAME TYPE.

Recommended products

Three bond Sealing paste

-



Front head

Removing camshafts

- Remove both head covers, the alternator side cover and remove the cap on the clutch cover in order to rotate the crankshaft.
- Remove the O ring.



See also

Head cover removal
[Removing the flywheel cover](#)

- Turn the crankshaft from the hole on the clutch cover.
- Move cylinder piston 1 (left rear piston) to the TDC overlap;
- Turn the crankshaft 150° in the direction of engine rotation (direction of travel).



- Insert the pin from the flywheel side, in the hole in the crankshaft.

NOTE

THE SPECIAL TOOL IS ONLY USED FOR IDENTIFYING THE CORRECT CRANKSHAFT POSITION. DO NOT USE IT FOR TIGHTENING OPERATIONS.

Specific tooling

020852Y Crankshaft timing pin



- Fit the pin for aligning the intake camshaft with the hole on U-bolt.
- If it was not possible before adjusting the valve clearance, check the engine timing.

Specific tooling

020851Y Camshaft timing pin



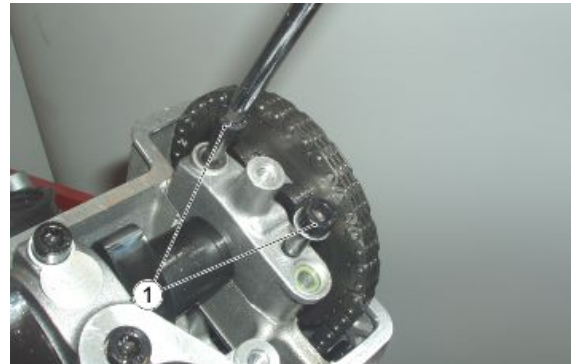
- Remove the two crankshaft and camshaft reference pins.
- Turn the crankshaft until the gear screw covered by the head when the hole on the camshaft gear is aligned with the hole on the U bolt, is visible.
- Block crankshaft rotation using one of the specific tools.
- Unscrew and remove the camshaft gear screw.
- Remove the crankshaft locking tool.



Specific tooling**020850Y Primary gear lock****020848Y Flywheel retainer**

Repeat the following operations:

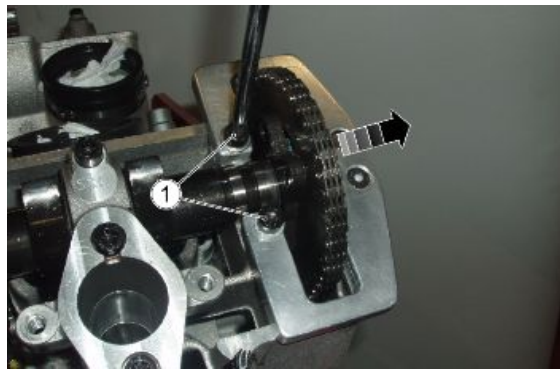
- move cylinder piston 1 (left rear piston) to TDC;
- turn the crankshaft 150° in the direction of engine rotation (direction of travel) in order to align the hole on the intake camshaft with the specific hole on the U bolt; this ensures that all the front cylinder bank valve springs are decompressed.
- Refit the camshaft timing setting pin in the hole in the U bolt on the front head, and refit the crankshaft timing pin from the flywheel side, to check that the timing setting was not altered while the engine was turned with only one camshaft drive gear fastener screw in place.
- Remove the camshaft timing pin.
- Unscrew and remove the two U bolt screws (1).
- Remove the U bolt and the oil pipe.

**Specific tooling****020851Y Camshaft timing pin****020852Y Crankshaft timing pin**

- Block crankshaft rotation using one of the specific tools.
- Unscrew and remove the second intake camshaft gear screw.
- Leave the gear on the camshaft.

**Specific tooling****020848Y Flywheel retainer****020850Y Primary gear lock**

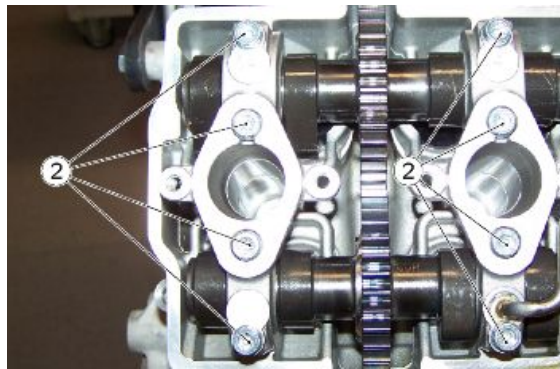
- Install the specific camshaft gear support tool.
- Fix it to the head using the two screws (1).
- Move the gear from the camshaft to the tool.



Specific tooling

020865Y Support for camshaft gear on head

- Unscrew and remove the eight screws (2), proceeding in stages and diagonally.
- Retrieve the washers from the screws near the spark plug holes.
- Remove the U bolts with the O rings and locator pins.



- Remove the intake and exhaust camshafts.

If the two camshafts are timed correctly, the exhaust camshaft gear tooth (indicated with a dot) is meshed with the trough of the intake camshaft gear (indicated with two dots).



Inspecting camshafts

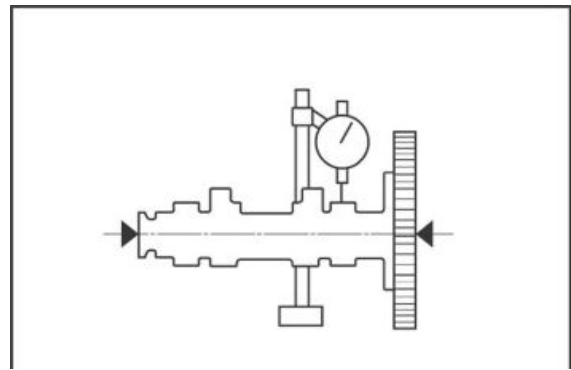
CAMSHAFT TOOTHED WHEEL CHECK

- Check that the camshaft gear works properly: if it is damaged or does not move smoothly, replace the timing chain and the camshaft gear.

CAMSHAFT LOBES

- Check that they do not show blue colouring, cracks or scratches; otherwise, replace the camshaft, gear and chain.

- Fasten the camshaft in horizontal position, as shown in the figure, and make it spin to check the eccentricity with a dial gauge; if necessary, replace the part.



Characteristic

Maximum camshaft axial clearance (intake/exhaust)

0.4 mm (0.0016 in)

WARNING

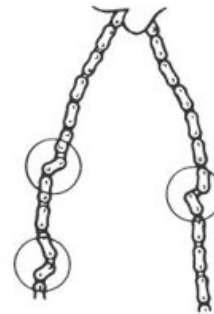
THE EXHAUST CAMSHAFTS OF THE FRONT AND REAR CYLINDER BANKS MUST BOTH BE OF THE SAME TYPE - EITHER WITH A CONVENTIONAL GEAR OR WITH A SELF-ADJUSTING CAM-SHAFT GEAR. THE TWO TYPES OF CAMSHAFT ARE INTERCHANGEABLE ON ALL ENGINES IRRESPECTIVE OF THE CAMSHAFT TYPE ORIGINALLY INSTALLED.

Check the timing chain for damage or stiffness while moving.

If necessary, replace the timing chain together with the camshaft gears.

Check the timing chain guide sliders for damage.

If necessary, replace the parts.



Installing camshafts

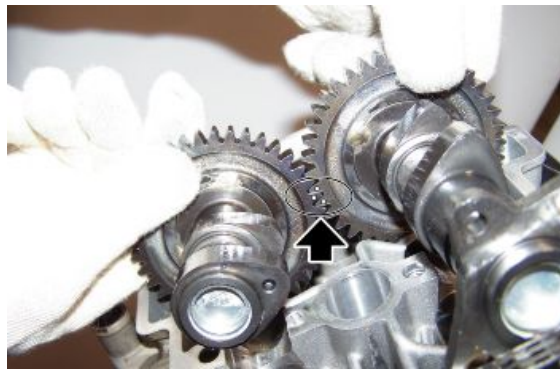
NOTE

Engines up to engine No. V4 2470 are equipped with conventional exhaust camshaft gears, while engines from engine No. V4 2471, are equipped with self-adjusting exhaust camshaft gears.



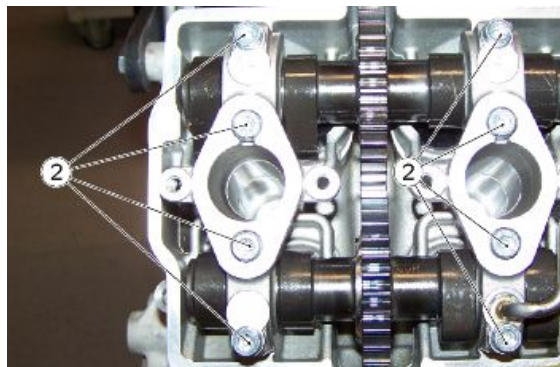
- Install the intake and exhaust camshafts on the front head, bearing in mind that:

the exhaust camshaft gear tooth (indicated with a dot) is meshed with the trough of the intake camshaft gear (indicated with two dots).



CLEAN THOROUGHLY THE SEATS OF THE GEAR RETAINER SCREWS, ON THE INTAKE CAMSHAFT.

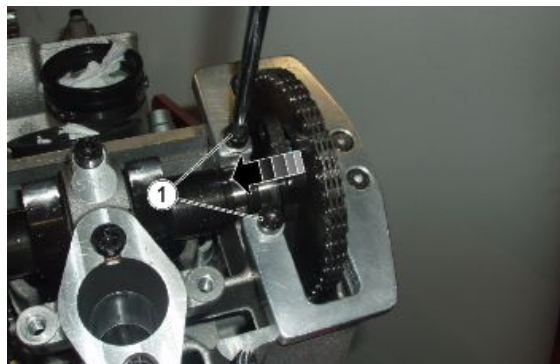
- Fit the U bolts with the nine O rings and locator pins.
- Fit the new washers under the screws (2) near the spark plug holes only.
- Tighten the seven screws (2) operating in stages and diagonally.
- Do not fit the eighth screw (2 - fastening the oil pipe) yet.



- Move the gear from the mounting tool to the camshaft.
- Unscrew and remove the two screws (1).
- Remove the tool.

Specific tooling

020865Y Support for camshaft gear on head



- Fit the U bolt and the oil pipe.
- Tighten the two U bolt screws (1) and the screw (2) that was not fitted previously.



- Align the intake camshaft with the specific hole on the U bolt.
- Insert the specified pin.

Specific tooling

020851Y Camshaft timing pin



- Apply Loctite 243 thread lock on the thread of the timing gear fastener screw. This screw must be replaced at each reassembly.
- Apply and loosely tighten the gear fixing screw on the camshaft.



- Block crankshaft rotation using one of the specific tools.
- Tighten the gear fixing screw on the camshaft to exactly the torque specified.
- Remove the crankshaft locking tool.



Specific tooling

020848Y Flywheel retainer

020850Y Primary gear lock

- Remove the two crankshaft and camshaft reference pins.
- Turn the crankshaft until the gear screw covered by the head when the hole on the camshaft gear is aligned with the hole on the U bolt, is visible.
- Block crankshaft rotation using one of the specific tools.
- Apply Loctite 243 thread lock on the thread of the second gear fastener



screw. This screw must be replaced at each reassembly.

- Tighten the second camshaft gear fixing screw to exactly the torque specified.
- Remove the crankshaft locking tool.

Specific tooling

020848Y Flywheel retainer

020850Y Primary gear lock

020851Y Camshaft timing pin

020852Y Crankshaft timing pin

- Turn the crankshaft back to the previous position in which the camshaft and U bolt holes were aligned; insert the reference pin while checking with the crankshaft reference pin, that the flywheel side hole and the hole on the crankshaft are perfectly aligned.
- If this is not the case, repeat the timing operations.

Specific tooling

020851Y Camshaft timing pin

020852Y Crankshaft timing pin

Front head removal

- Remove both head covers, the alternator side cover and remove the cap on the clutch cover in order to rotate the crankshaft.
- Remove the O ring.



See also

Head cover removal

[Removing the flywheel cover](#)

- Turn the crankshaft from the hole on the clutch cover.
- Move cylinder piston 1 (left rear piston) to the overlap TDC;
- Turn the crankshaft 150° in the engine rotation direction (direction of travel), in order to align the hole on the intake camshaft with the specific hole on the U bolt; this ensures that all the front cylinder bank valve springs are decompressed.



- Turn the crankshaft until the gear screw covered by the head when the hole on the camshaft gear is aligned with the hole on the U bolt, is visible.
- Block crankshaft rotation using one of the specific tools.
- Unscrew and remove the camshaft gear screw.
- Remove the crankshaft locking tool.



Specific tooling

020850Y Primary gear lock

020848Y Flywheel retainer

Repeat the following operations:

- move cylinder piston 1 (left rear piston) to TDC;
- turn the crankshaft 150° in the engine rotation direction (direction of travel), in order to align the hole on the intake camshaft with the specific hole on the U bolt; this ensures that all the front cylinder bank valve springs are decompressed.
- Block crankshaft rotation using one of the specific tools.



- Unscrew and remove the second intake camshaft gear screw.
- Remove the crankshaft locking tool.

Specific tooling

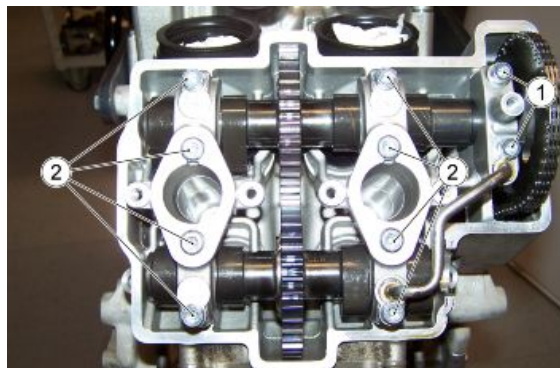
020850Y Primary gear lock

020848Y Flywheel retainer

- Slide the gear off the intake camshaft.
- Block the gear to the timing chain with a clamp.



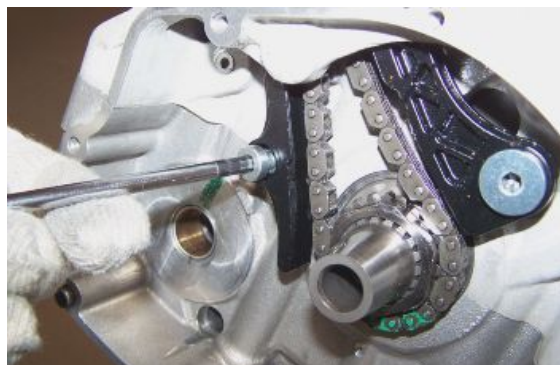
- Unscrew and remove the ten screws (1-2), proceeding in stages and in a crossed pattern.
- Retrieve the washers from the screws (2) near the spark plug holes.
- Remove the U bolts with the O rings and locator pins.



NOTE

MARK THE COMPONENTS TO PREVENT INCORRECT RE-FITTING.

- Remove the intake and exhaust camshafts from the front head.
- Unscrew and remove the fixed chain slider screw.
- Remove the fixed chain slider.



- Unscrew and remove the mobile chain slider screw.
- Remove the mobile chain slider.



- Remove the camshaft control gear connected with a clamp to the timing chain.



- Unscrew and remove the two head fixing screws (a - b) from the flywheel side.



- Loosen the six nuts on the stud bolts, proceeding in the following order 6 - 5 - 4 - 3 - 2 - 1.
- After loosening all nuts, remove them in order indicated above.



- Remove the front head, slipping it off the stud bolts.
- Collect the gasket and the two dowel pins.



- Remove the chain tensioner complete with O-ring using the specific tool.
- If the O-ring is not on the chain tensioner, make sure it was not left in the crankcase seat.



REPLACE THE O RING UPON EACH REMOVAL.

Specific tooling

020883Y Tool for fitting/removing the timing chain tensioner



Front head check

Check that:

- The contact surfaces with the cover and the crankcase are not scored or damaged so they jeopardise a perfect seal.
- Check the status of the valve seats.
- Check that the routing of the oil pipes is free and if required, clean them by blowing a jet of compressed air.

Front head fitting

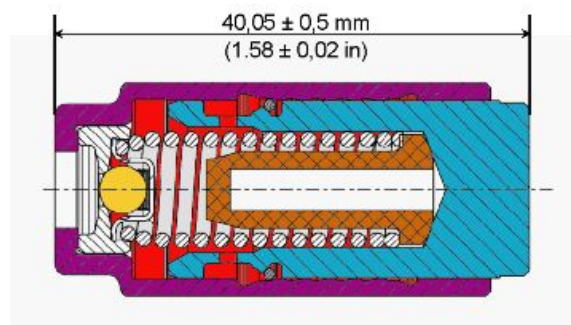
- Install a new O ring on the chain tensioner



REPLACE THE O RING UPON EACH REMOVAL.



- Compress the chain tensioner completely, making sure that the total length is 40.05 ± 0.5 mm (1.58 ± 0.02 in).



- Insert the chain tensioner into the crankcase, being careful to position it correctly.



WASHER

We recommend installing a washer between the crankcase and the chain tensioner to optimise the functionality of the timing system.

This washer is available as a spare part.



- Fit the washer onto the chain tensioner then install the chain tensioner in the relative seat in the crankcase. Take particular care to ensure that the washer seats correctly, as the

functionality of the timing system may be compromised if the washer is bent or incorrectly positioned.



THIS WASHER CANNOT BE INSTALLED ON THE CHAIN TENSIONER OF ONE CYLINDER BANK ALONE - ALWAYS INSTALL WASHERS ON BOTH CHAIN TENSIONERS.

- Place a new gasket between the crankcase and the head.
- Place the two dowel pins.



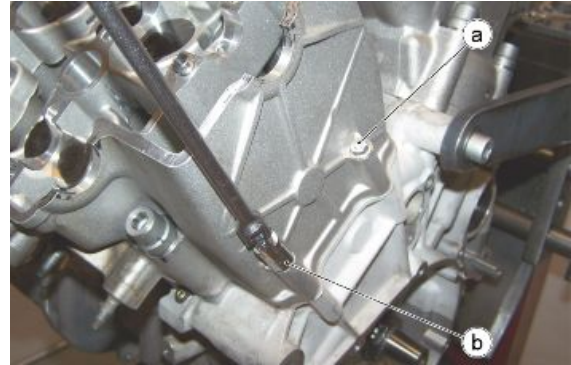
- Install the head.



- Pretighten the six nuts on the stud bolts proceeding in the following order: 1 - 2 - 3 - 4 - 5 - 6.
- Then tighten them fully following the same order.



- Tighten the two screws according to the sequence (a - b)



- Install the camshaft control gear connected with a clamp to the timing chain.
- Keep the gear in position with the chain tightened.



THE SIDE WITH THE BEVELLED HOLE IN THE TIMING SYSTEM GEAR MUST ALWAYS FACE THE EXTERIOR OF THE HEAD.



- Install both chain sliders and fasten them with the specific screws.



- Turn the crankshaft from the hole on the clutch cover.
- Move cylinder piston 1 (left rear piston) to the TDC overlap;
- Turn the crankshaft 150° in the direction of engine rotation (direction of travel).



- Insert the pin from the flywheel side, in the hole in the crankshaft.

NOTE

THE SPECIAL TOOL IS ONLY USED FOR IDENTIFYING THE CORRECT CRANKSHAFT POSITION. DO NOT USE IT FOR TIGHTENING OPERATIONS.

Specific tooling

020852Y Crankshaft timing pin

**NOTE**

THIS ENGINE HAS CAMSHAFTS OF THE EXHAUST VALVES WITH CLEARANCE RECOVERY.



- Install the intake and exhaust camshafts on the front head, bearing in mind that: the exhaust camshaft gear tooth (indicated with a dot) is meshed with the trough of the intake camshaft gear (indicated with two dots).



CLEAN THOROUGHLY THE SEATS OF THE GEAR RETAINER SCREWS, ON THE INTAKE CAMSHAFT.

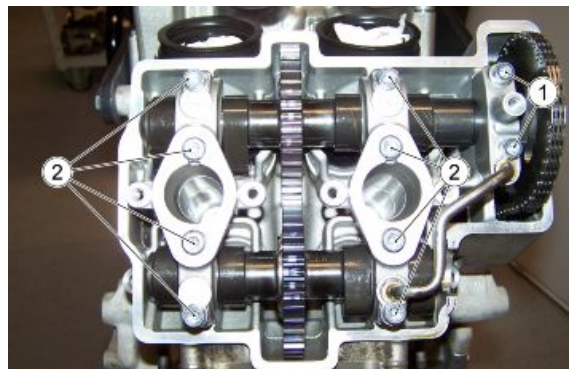
- Check the number engraved on the U bolts, which must correspond with the one engraved on the head.
- If the U bolts between the two heads are inverted, camshaft seizure may occur



IT IS NOT POSSIBLE TO REPLACE ONLY ONE U BOLT, IF NECESSARY: REPLACE THE ENTIRE HEAD.



- Fit the U bolts with the nine O rings and locator pins.
- Install the oil pipe.
- Fit the new washers under the screws (2) near the spark plug holes only.
- Tighten the ten screws (1 - 2) working in stages and diagonally.



- Cut the clamp that binds the chain to the gear.
- Position the gear on the camshaft so that the timing hole and the gear fixing screw hole are centred with the gear slot.
- Insert the specific timing pin.



Specific tooling

020851Y Camshaft timing pin



- Apply Loctite 243 thread lock on the thread of the timing gear fastener screw. This screw must be replaced at each reassembly.
- Apply and loosely tighten the gear fixing screw on the camshaft.



- Protect the edge of the head with rubber.
- Load the chain tensioner with special tool.

Specific tooling

020855Y Lever for engaging the chain tensioner

- Block crankshaft rotation using one of the specific tools.
- Tighten the gear fixing screw on the camshaft to exactly the torque specified.
- Remove the crankshaft locking tool.



Specific tooling

020848Y Flywheel retainer

020850Y Primary gear lock

- Remove the two crankshaft and camshaft reference pins.
- Turn the crankshaft until the gear screw covered by the head when the hole on the camshaft gear is aligned with the hole on the U bolt, is visible.
- Block crankshaft rotation using one of the specific tools.
- Apply Loctite 243 thread lock on the thread of the second gear fastener screw. This screw must be replaced at each reassembly.
- Tighten the second camshaft gear fixing screw to exactly the torque specified.
- Remove the crankshaft locking tool.



Specific tooling

020848Y Flywheel retainer

020850Y Primary gear lock

020851Y Camshaft timing pin

020852Y Crankshaft timing pin

- Turn the crankshaft back to the previous position in which the camshaft and U bolt holes were aligned; insert the reference pin while checking with the crankshaft reference pin, that the flywheel side hole and the hole on the crankshaft are perfectly aligned.
- If this is not the case, repeat the timing operations.

Specific tooling

020851Y Camshaft timing pin

020852Y Crankshaft timing pin

Rear head

Removing camshafts

- Remove the rear head cover and the clutch cover.
- Move cylinder piston 1 (left rear piston) to the TDC;
- Turn the crankshaft 450° (one complete turn + 90°) in the direction of motor rotation (direction of travel).

- Insert the pin from the clutch side into the hole in the crankshaft.

NOTE

THE SPECIAL TOOL IS ONLY USED FOR IDENTIFYING THE CORRECT CRANKSHAFT POSITION. DO NOT USE IT FOR TIGHTENING OPERATIONS.

Specific tooling

020852Y Crankshaft timing pin

**See also**

Head cover removal

[Removing the clutch cover](#)

- Fit the pin for aligning the intake camshaft with the hole on U-bolt.
- If it was not possible before adjusting the valve clearance, check the engine timing.

Specific tooling

020851Y Camshaft timing pin



- Remove the two crankshaft and camshaft reference pins.
- Turn the crankshaft until the gear screw covered by the head when the hole on the camshaft gear is aligned with the hole on the U bolt, is visible.
- Block crankshaft rotation using one of the specific tools.
- Unscrew and remove the camshaft gear screw.
- Remove the crankshaft locking tool.

Specific tooling

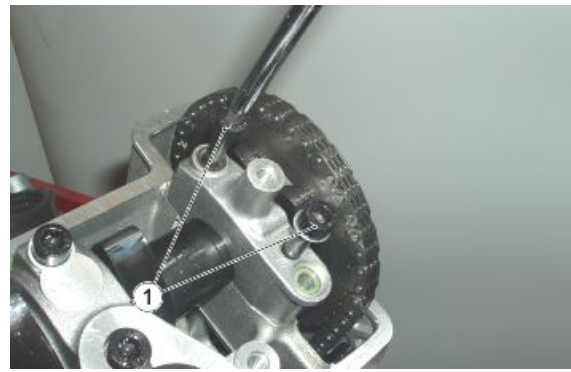
020850Y Primary gear lock

020848Y Flywheel retainer



Repeat the following operations:

- move cylinder piston 1 (left rear piston) to TDC;
- turn the crankshaft by 450° (one complete turn + 90°) in the direction of engine rotation (direction of travel) to align the hole on the intake camshaft with the specific hole on the U bolt. This ensures that all the rear cylinder bank valve springs are decompressed.
- Refit the camshaft timing setting pin in the hole in the U bolt on the rear head, and refit the crankshaft timing pin from the clutch side, to check that the timing setting was not altered while the engine was turned with only one camshaft drive gear fastener screw in place.
- Remove the camshaft timing pin.
- Unscrew and remove the two U bolt screws (1).
- Remove the U bolt and the oil pipe.



Specific tooling

020851Y Camshaft timing pin

020852Y Crankshaft timing pin

- Block crankshaft rotation using one of the specific tools.
- Unscrew and remove the second intake camshaft gear screw.
- Leave the gear on the camshaft.

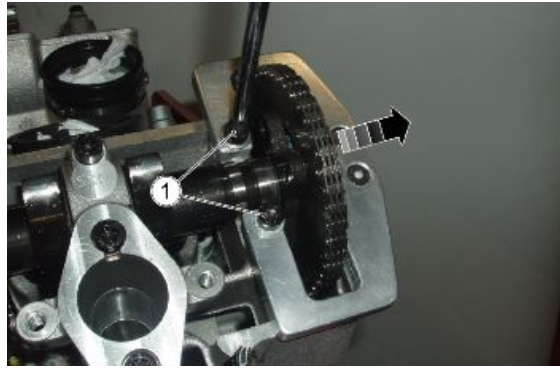
Specific tooling

020848Y Flywheel retainer

020850Y Primary gear lock



- Install the specific camshaft gear support tool.
- Fix it to the head using the two screws (1).
- Move the gear from the camshaft to the tool.



Specific tooling

020865Y Support for camshaft gear on head

- Unscrew and remove the eight screws (2), proceeding in stages and diagonally.
- Retrieve the washers from the screws near the spark plug holes.
- Remove the U bolts with the O rings and locator pins.



- Remove the intake and exhaust camshafts.

If the two camshafts are timed correctly, the intake camshaft gear tooth (indicated with one dot) is meshed with the trough of the exhaust camshaft gear (indicated with two dots).



Inspecting camshafts

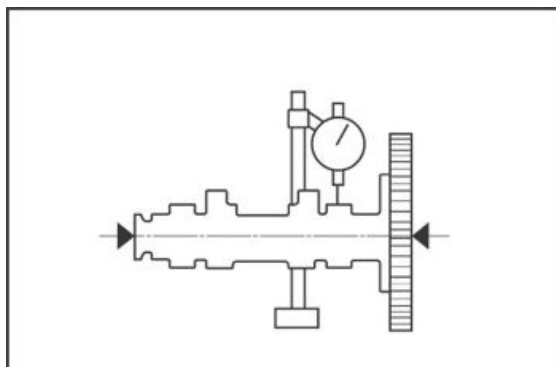
CAMSHAFT TOOTHED WHEEL CHECK

- Check that the camshaft gear works properly: if it is damaged or does not move smoothly, replace the timing chain and the camshaft gear.

CAMSHAFT LOBES

- Check that they do not show blue colouring, cracks or scratches; otherwise, replace the camshaft, gear and chain.

- Fasten the camshaft in horizontal position, as shown in the figure, and make it spin to check the eccentricity with a dial gauge; if necessary, replace the part.



Characteristic

Maximum camshaft axial clearance (intake/exhaust)

0.4 mm (0.0016 in)

WARNING

THE EXHAUST CAMSHAFTS OF THE FRONT AND REAR CYLINDER BANKS MUST BOTH BE OF THE SAME TYPE - EITHER WITH A CONVENTIONAL GEAR OR WITH A SELF-ADJUSTING CAMSHAFT GEAR. THE TWO TYPES OF CAMSHAFT ARE INTERCHANGEABLE ON ALL ENGINES IRRESPECTIVE OF THE CAMSHAFT TYPE ORIGINALLY INSTALLED.

Check the timing chain for damage or stiffness while moving.

If necessary, replace the timing chain together with the camshaft gears.

Check the timing chain guide sliders for damage.

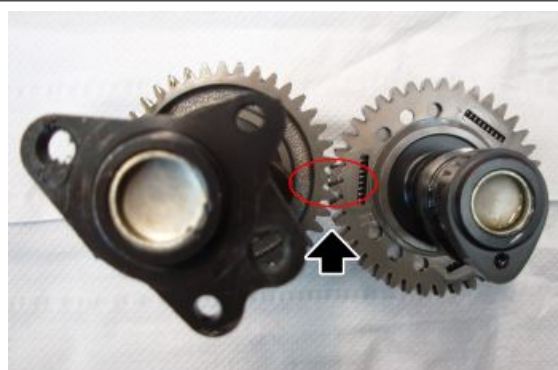
If necessary, replace the parts.



Installing camshafts

NOTE

Engines up to engine No. V4 2470 are equipped with conventional exhaust camshaft gears, while engines from engine No. V4 2471, are equipped with self-adjusting exhaust camshaft gears.



- Install the intake and exhaust camshafts on the rear head, remembering that:

the intake camshaft gear tooth (indicated with a dot) is inserted in the groove of the exhaust camshaft gear (indicated with two dots).



CLEAN THOROUGHLY THE SEATS OF THE GEAR RETAINER SCREWS, ON THE INTAKE CAMSHAFT.



- Fit the U bolts with the nine O rings and locator pins.
- Fit the new washers under the screws (2) near the spark plug holes only.
- Tighten the seven screws (2) operating in stages and diagonally.
- Do not fit the eighth screw (2 - fastening the oil pipe) yet.



- Move the gear from the mounting tool to the camshaft.
- Unscrew and remove the two screws (1).
- Remove the tool.

Specific tooling

020865Y Support for camshaft gear on head



- Fit the U bolt and the oil pipe.
- Tighten the two U bolt screws (1) and the screw (2) that was not fitted previously.



- Align the intake camshaft with the specific hole on the U bolt.
- Insert the specified pin.

Specific tooling

020851Y Camshaft timing pin



- Apply Loctite 243 thread lock on the thread of the timing gear fastener screw. This screw must be replaced at each reassembly.
- Apply and loosely tighten the gear fixing screw on the camshaft.



- Block crankshaft rotation using one of the specific tools.
- Tighten the gear fixing screw on the camshaft to exactly the torque specified.
- Remove the crankshaft locking tool.



Specific tooling

020848Y Flywheel retainer

020850Y Primary gear lock

- Remove the two crankshaft and camshaft reference pins.
- Turn the crankshaft until the gear screw covered by the head when the hole on the camshaft gear is aligned with the hole on the U bolt, is visible.
- Block crankshaft rotation using one of the specific tools.
- Apply Loctite 243 thread lock on the thread of the second gear fastener



screw. This screw must be replaced at each reassembly.

- Tighten the second camshaft gear fixing screw to exactly the torque specified.
- Remove the crankshaft locking tool.

Specific tooling

020848Y Flywheel retainer

020850Y Primary gear lock

020851Y Camshaft timing pin

020852Y Crankshaft timing pin

- Turn the crankshaft back to the previous position in which the camshaft and U bolt holes were aligned; Refit the reference pin while checking, using the crankshaft reference pin, that the clutch side hole and the hole in the crankshaft are perfectly aligned.
- If this is not the case, repeat the timing operations.

Specific tooling

020851Y Camshaft timing pin

020852Y Crankshaft timing pin

Rear head removal

- Remove the rear head cover and the clutch cover.
- Move cylinder piston 1 (left rear piston) to the TDC;
- Turn the crankshaft 450° (one complete turn + 90°) in the direction of motor rotation (direction of travel) in order to align the hole on the intake camshaft gear with the hole on the U-bolt. This ensures that all the rear cylinder bank valve springs are decompressed.

- Turn the crankshaft until the gear screw covered by the head when the hole on the camshaft gear is aligned with the hole on the U bolt, is visible.
- Block crankshaft rotation using one of the specific tools.
- Unscrew and remove the camshaft gear screw.
- Remove the crankshaft locking tool.



Specific tooling

020850Y Primary gear lock

020848Y Flywheel retainer**See also**

Head cover removal

[Removing the clutch cover](#)

Repeat the following operations:

- move cylinder piston 1 (left rear piston) to TDC;
- turn the crankshaft by 450° (one complete turn + 90°) in the direction of engine rotation (direction of travel) to align the hole on the intake camshaft with the specific hole on the U bolt. This ensures that all the rear cylinder bank valve springs are decompressed.
- Block crankshaft rotation using one of the specific tools.
- Unscrew and remove the second intake camshaft gear screw.
- Remove the crankshaft locking tool.

**Specific tooling**

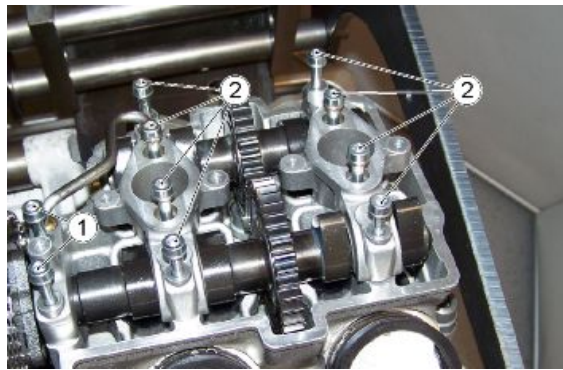
020850Y Primary gear lock

020848Y Flywheel retainer

- Slide the gear off the intake camshaft.
- Block the gear to the timing chain with a clamp.



- Unscrew and remove the ten screws (1-2), proceeding in stages and in a crossed pattern.
- Retrieve the washers from the screws (2) near the spark plug holes.
- Remove the U bolts with the O rings and locator pins.

**NOTE**

MARK THE COMPONENTS TO PREVENT INCORRECT RE-FITTING.

- Remove the intake and exhaust camshafts from the rear head.

- Unscrew and remove the mobile chain slider screw.
- Remove the mobile chain slider.



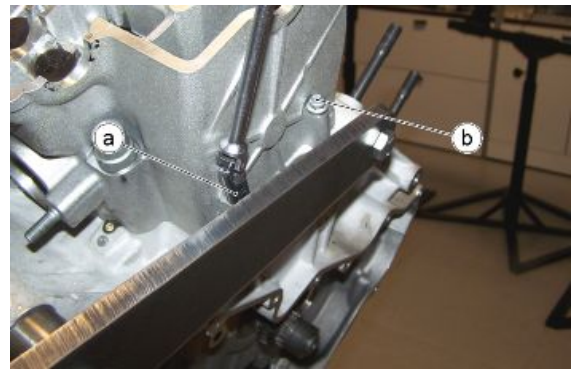
- Unscrew and remove the fixed chain slider screw.
- Remove the fixed chain slider.



- Remove the camshaft control gear connected with a clamp to the timing chain.



- Unscrew and remove the two head fastener screws (a - b) from the clutch side.



- Loosen the six nuts on the stud bolts, proceeding in the following order 6 - 5 - 4 - 3 - 2 - 1.
- After loosening all nuts, remove them in order indicated above.



- Remove the rear head, slipping it off the stud bolts.
- Collect the gasket and the two dowel pins.



- Remove the chain tensioner complete with O-ring using the specific tool.
- If the O-ring is not on the chain tensioner, make sure it was not left in the crankcase seat.

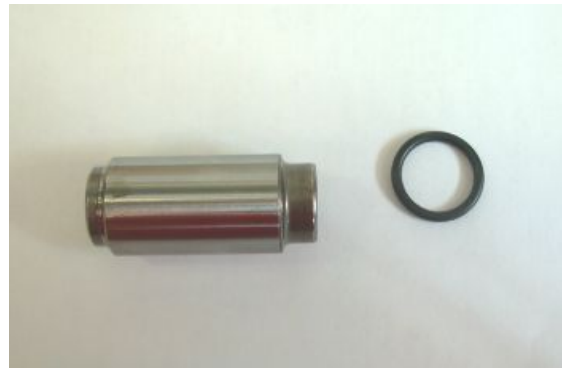


REPLACE THE O RING UPON EACH REMOVAL.

Specific tooling

020883Y Tool for fitting/removing the timing chain tensioner





Rear head check

Check that:

- The contact surfaces with the cover and the crankcase are not scored or damaged so they jeopardise a perfect seal.
- Check the status of the valve seats.
- Check that the routing of the oil pipes is free and if required, clean them by blowing a jet of compressed air.

Rear head fitting

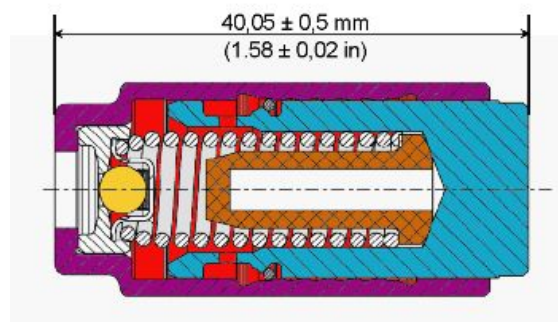
- Install a new O ring on the chain tensioner



REPLACE THE O RING UPON EACH REMOVAL.



- Compress the chain tensioner completely, making sure that the total length is $40,05 \pm 0,5$ mm ($1,58 \pm 0,02$ in).



- Insert the chain tensioner into the crankcase, being careful to position it correctly.



WASHER

We recommend installing a washer between the crankcase and the chain tensioner to optimise the functionality of the timing system.

This washer is available as a spare part.



- Fit the washer onto the chain tensioner then install the chain tensioner in the relative seat in the crankcase. Take particular care to ensure that the washer seats correctly, as the functionality of the timing system may be compromised if the washer is bent or incorrectly positioned.



THIS WASHER CANNOT BE INSTALLED ON THE CHAIN TENSIONER OF ONE CYLINDER BANK ALONE - ALWAYS INSTALL WASHERS ON BOTH CHAIN TENSIONERS.

- Place a new gasket between the crankcase and the head.
- Place the two dowel pins.



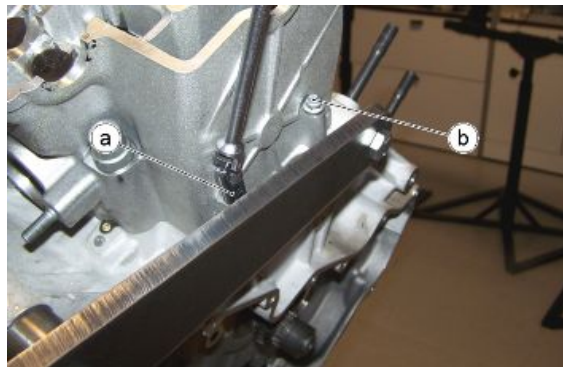
- Install the head.



- Pretighten the six nuts on the stud bolts proceeding in the following order: 1 - 2 - 3 - 4 - 5 - 6.
- Then tighten them fully following the same order.



- Tighten the two screws according to the sequence (a - b)



- Install the camshaft control gear connected with a clamp to the timing chain.
- Keep the gear in position with the chain tightened.



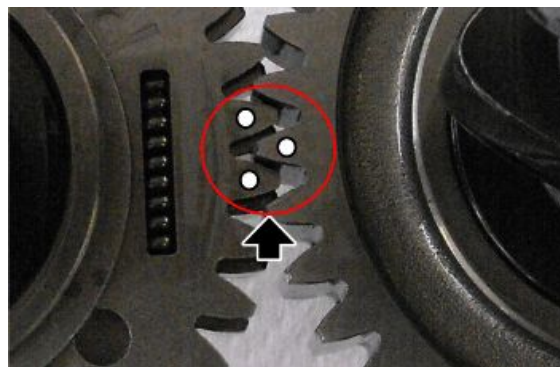
THE SIDE WITH THE BEVELLED HOLE IN THE TIMING SYSTEM GEAR MUST ALWAYS FACE THE EXTERIOR OF THE HEAD.



- Install both chain sliders and fasten them with the specific screws.

**NOTE**

THIS ENGINE HAS CAMSHAFTS OF THE EXHAUST VALVES WITH CLEARANCE RECOVERY.



- Install the intake and exhaust camshafts on the rear head, remembering that: the intake camshaft gear tooth (indicated with a dot) is inserted in the groove of the exhaust camshaft gear (indicated with two dots).



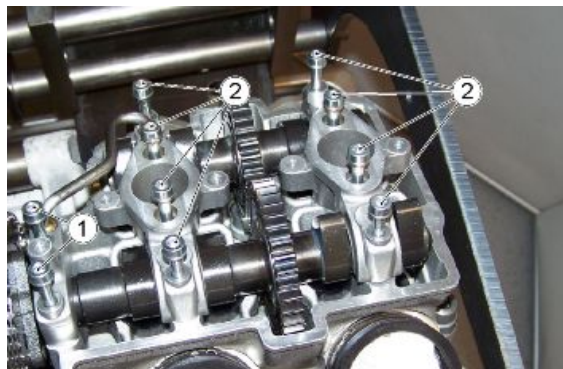
CLEAN THOROUGHLY THE SEATS OF THE GEAR RETAINER SCREWS, ON THE INTAKE CAMSHAFT.

- Check the number engraved on the U bolts, which must correspond with the one engraved on the head.
- If the U bolts between the two heads are inverted, camshaft seizure may occur



IT IS NOT POSSIBLE TO REPLACE ONLY ONE U BOLT, IF NECESSARY: REPLACE THE ENTIRE HEAD.

- Fit the U bolts with the nine O rings and locator pins.
- Install the oil pipe.
- Fit the new washers under the screws (2) near the spark plug holes only.
- Tighten the ten screws (1 - 2) working in stages and diagonally.



- Cut the clamp that binds the chain to the gear.
- Position the gear on the camshaft so that the timing hole and the gear fixing screw hole are centred with the gear slot.
- Insert the specific timing pin.



Specific tooling

020851Y Camshaft timing pin

- Apply Loctite 243 thread lock on the thread of the timing gear fastener screw. This screw must be replaced at each reassembly.
- Apply and loosely tighten the gear fixing screw on the camshaft.





- Protect the edge of the head with rubber.
- Load the chain tensioner with special tool.

Specific tooling

020855Y Lever for engaging the chain tensioner

- Block crankshaft rotation using one of the specific tools.
- Tighten the gear fixing screw on the camshaft to exactly the torque specified.
- Remove the crankshaft locking tool.



Specific tooling

020848Y Flywheel retainer

020850Y Primary gear lock

- Remove the two crankshaft and camshaft reference pins.
- Turn the crankshaft until the gear screw covered by the head when the hole on the camshaft gear is aligned with the hole on the U bolt, is visible.
- Block crankshaft rotation using one of the specific tools.
- Apply Loctite 243 thread lock on the thread of the second gear fastener screw. This screw must be replaced at each reassembly.
- Tighten the second camshaft gear fixing screw to exactly the torque specified.



- Remove the crankshaft locking tool.

Specific tooling

020848Y Flywheel retainer

020850Y Primary gear lock

020851Y Camshaft timing pin

020852Y Crankshaft timing pin

- Turn the crankshaft back to the previous position in which the camshaft and U bolt holes were aligned; Refit the reference pin while checking, using the crankshaft reference pin, that the clutch side hole and the hole in the crankshaft are perfectly aligned.
- If this is not the case, repeat the timing operations.

Specific tooling

020851Y Camshaft timing pin

020852Y Crankshaft timing pin

Valves

Valve removal

- Remove the head.
- Place the head on supporting surface.
- Number the valves and their bucket tappets in order to position them correctly upon refitting.
- Remove the bucket tappets and the adjustment shims using a magnet.



- Compress the valve springs with the specific wrench and with the spring compressing tool.



Specific tooling

AP8140179 Valve spring compressor

020853Y Intake valve spring compressor

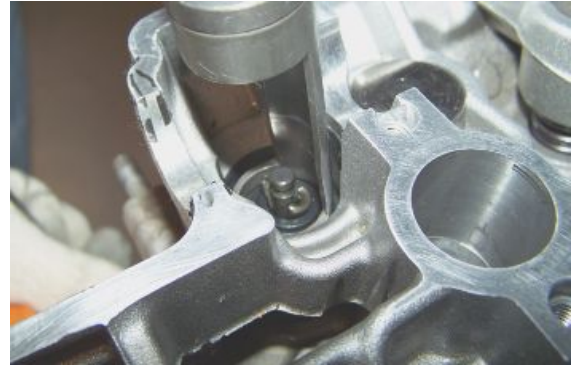
020854Y Exhaust valve spring compressor

See also

Front head removal

Rear head removal

- Remove the cotters using a magnet.



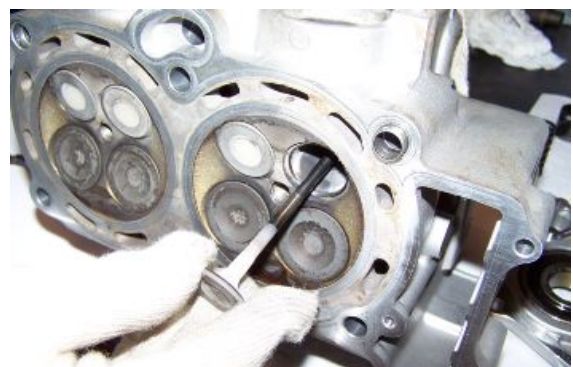
- Release the valve springs.
- Remove the upper cap and the springs.

CAUTION

THE INTAKE VALVES HAVE A DOUBLE SPRING WHEREAS THE EXHAUST VALVES HAVE A SINGLE SPRING.



- Remove the valves.



Valve check

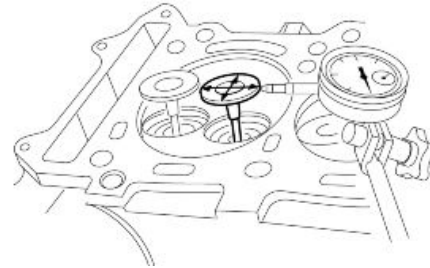
CAUTION

REPLACE THE VALVES ONE AT A TIME. DO NOT MIX THE COMPONENTS. EACH VALVE MUST BE INSERTED INTO ITS SEAT, WHICH IS MARKED PRIOR TO REMOVAL.

VALVE STEM DEVIATION

Lift up the valve approx. 10 mm (0.39 in) from its seat.

Measure the valve stem deviation in two perpendicular directions and position the dial gauge as shown in the figure.



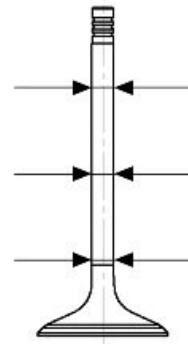
Characteristic

Valve stem distortion

0.25 mm (0.0098 in)

If the valve stem, when measured with a micrometer, is worn to its limit and the clearance exceeds the specified limit, replace the valve.

Recheck the clearance after replacing the valve.



Characteristic

Intake valve stem diameter

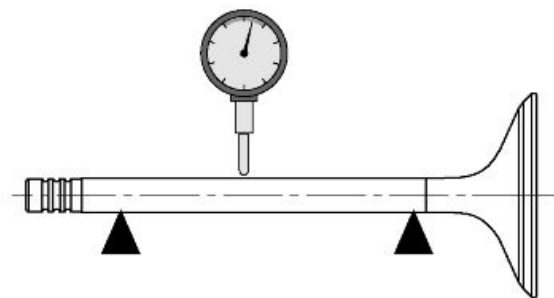
4.985 - 4.965 mm (0.1963 - 0.1954 in)

Exhaust valve stem diameter

4.975 - 4.955 mm (0.1959 - 0.1951 in)

Support the valve with two "V" blocks as shown and check the run-out with a dial gauge.

If the run-out exceeds the specified limit, replace the valve.



Characteristic

Valve stem run-out

0.05 mm (0.0020 in)

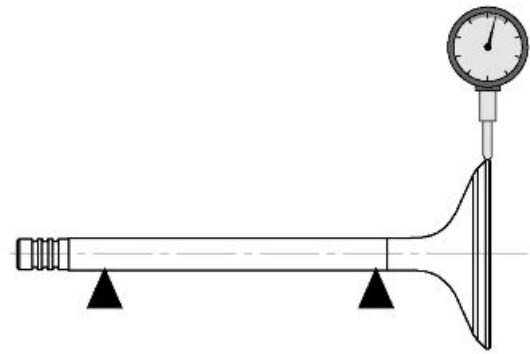
Position the dial gauge at a right angle to the valve head face and measure the eccentricity.

If the eccentricity exceeds the specified limit, replace the valve.

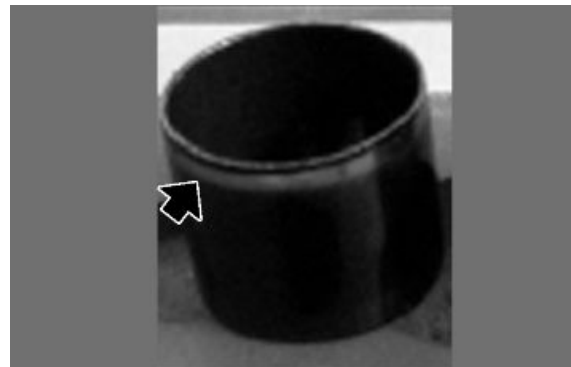
Characteristic

Valve head eccentricity

0.03 mm (0.0012 in)

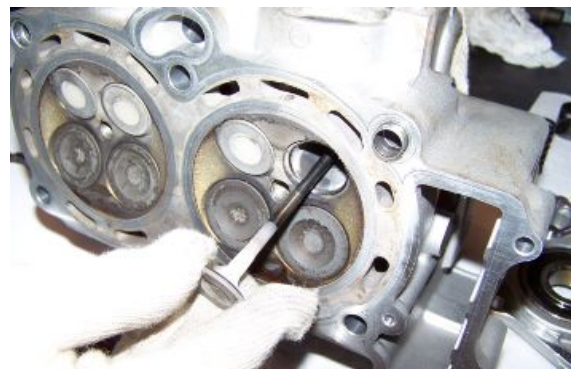


Coating may get slightly damaged in the indicated area.



Valve installation

- Lubricate the valve stem and insert the valves on the valve guide.



- Position the springs with the closest turns facing the head of the valve

CAUTION

THE INTAKE VALVES HAVE A DOUBLE SPRING WHEREAS THE EXHAUST VALVES HAVE A SINGLE SPRING.



- Fit the caps.



- Compress the valve springs with the specific wrench and with the spring compressing tool.
- Insert the cotters into the seat



Specific tooling

AP8140179 Valve spring compressor

020853Y Intake valve spring compressor

020854Y Exhaust valve spring compressor

- Release the wrench, checking that the cotters are positioned correctly in the valve grooves.
- Position the adjustment shims and then the bucket tappets.



NEW SPRING KIT

From engine number:

- V4-A 4215 onwards

and on the following engine numbers:

- V4-A 3017
- V4-A 3635
- V4-A 4153
- V4-A 4180
- V4-A 4205

the engine has been equipped with a new valve timing system spring kit.

The procedure for installing the new springs is the same as the procedure described for the previous springs.

CAUTION

THE NEW VALVE KIT MAY ALSO BE INSTALLED ON ALL PRIOR ENGINES.

CAUTION

THE NEW SPRINGS CANNOT BE INSTALLED TOGETHER WITH OLD SPRINGS. WHEN USING THE NEW SPRINGS, THE SPRINGS ON ALL SIXTEEN VALVES MUST BE REPLACED.

As before, the intake valves are fitted with two springs while the exhaust valves are fitted with a single spring.

The new intake valve springs are marked blue and the new exhaust springs are marked red.

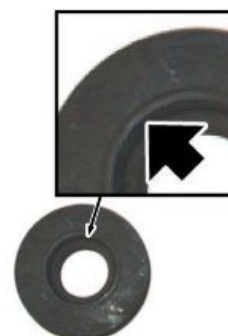
The old intake valve springs are marked blue and the old exhaust springs are marked yellow.

The new springs are identifiable as they are marked differently than the old springs; on the new springs, the first turn is coloured completely whereas the old springs are marked with lines on the side.

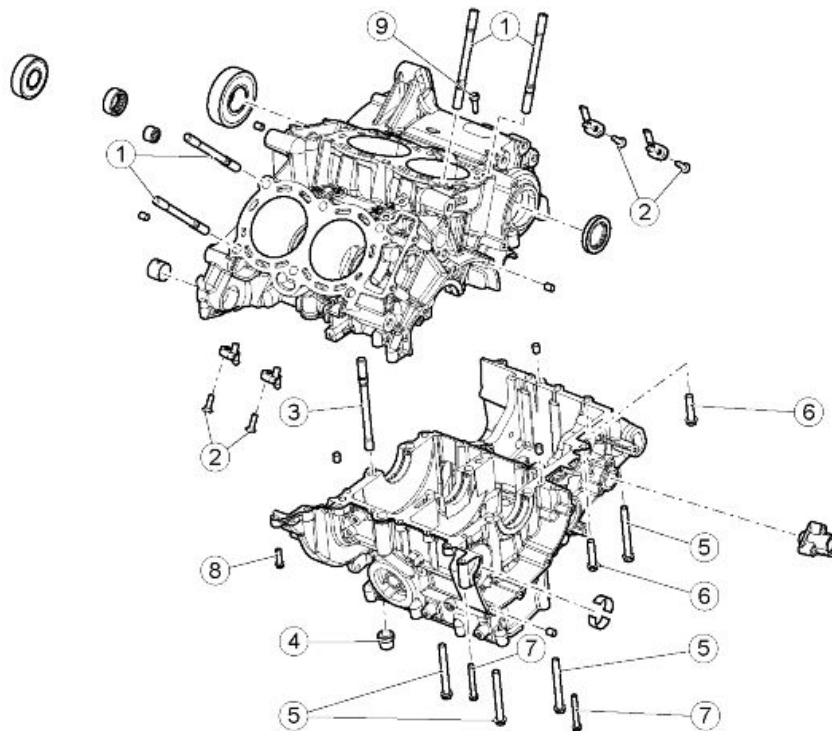


CAUTION

WHEN REPLACING ALL THE SPRINGS, IT IS ALSO NECESSARY TO REPLACE ALL THE LOWER CAPS OF THE INTAKE VALVES. THE NEW CAPS CAN BE DISTINGUISHED FROM THE OLD CAPS AS THEY HAVE A CIRCULAR GROOVE WHICH IS ABSENT ON THE OLD VALVES. THE CAPS OF THE EXHAUST VALVES ARE THE SAME AS BEFORE

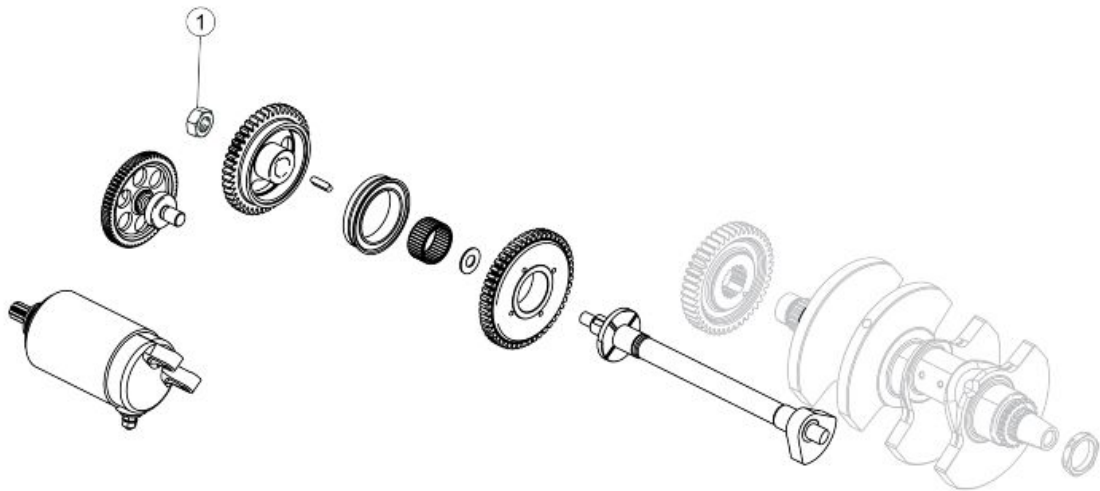


Crankcase



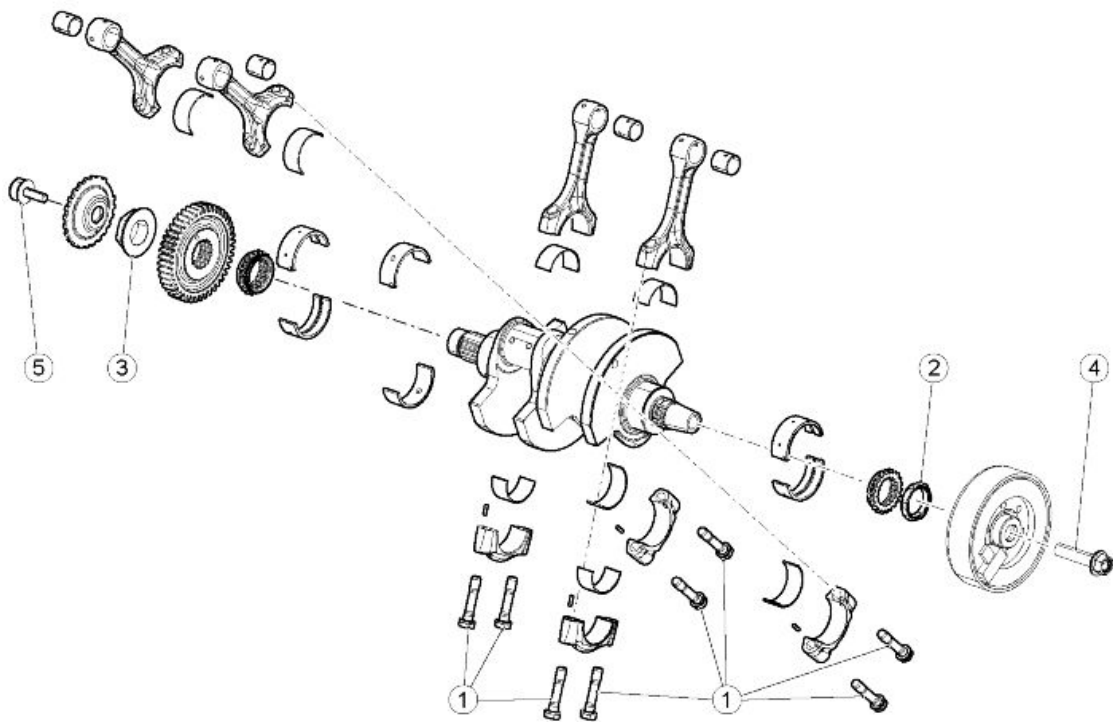
CRANKCASES

pos.	Description	Type	Quantity	Torque	Notes
1	Head stud bolts	-	12	20 Nm (14.75 lbf ft)	Loct. 648 or 270
2	Special screw for piston cooling oil jet	-	4	6 Nm (4.42 lbf ft)	Loct. 2045
3	Crankcase stud bolts	-	6	20 Nm (14.75 lbf ft)	Loct. 648 or 270
4	Main crank flanged nut	-	6	30 + 55 Nm (22.13 + 40.57 lbf ft)	Molykote - lubricate the thread and under the head
5	Crankcase fixing screw	M8x70	4	25 Nm (18.44 lbf ft)	Lubricate the thread and under the head
6	Crankcase fixing screw	M8x35	3	25 Nm (18.44 lbf ft)	Lubricate the thread and under the head
7	Crankcase fixing screw	M6x45	2	10 Nm (7.37 lbf ft)	Lubricate the thread and under the head
8	Crankcase fixing screw	M6x20	5	10 Nm (7.37 lbf ft)	Lubricate the thread and under the head
9	Crankcase fixing screw	M6x20	5	10 Nm (7.37 lbf ft)	Lubricate the thread and under the head



IGNITION UNIT

pos.	Description	Type	Quantity	Torque	Notes
1	Hex headed nut, cl.10 type 2 ISO 8674	M10x1	1	50 Nm (36.88 lbf ft)	Loct. 243

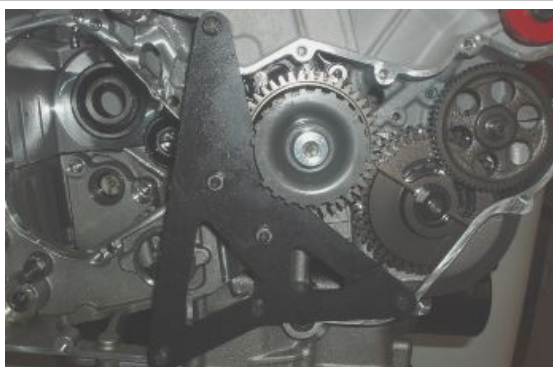


CRANKSHAFT

pos.	Description	Type	Quantity	Torque	Notes
1	Connecting rod screws	-	8	15 Nm (11.06 lbf ft) + 40° + 60°	Lubricate the thread and under the head with Molykote
2	Fastener ring nut for alternator side timing sprocket	-	1	100 Nm (73.76 lbf ft)	Loct. 243
3	Primary sprocket fixing ring nut	-	1	200 Nm (147.51 lbf ft)	Loct. 243
4	Alternator fixing screw	M12x1.25	1	120 Nm (88.51 lbf ft)	-
5	Tone wheel fixing screw	M8x1.25	1	50 Nm (36.88 lbf ft)	Loct. 3M or 270

Balancing countershaft removal

- To extract the balancing countershaft, first remove: the clutch cover and the alternator cover.
- Turn the crankshaft and align the references on the countershaft gear and the primary shaft gear.
- Block crankshaft rotation using the specific tool.

**Specific tooling****020850Y Primary gear lock**

- Remove the starting intermediate gear.
- Unscrew and remove the nut.

**See also**

[Removing the clutch cover](#)

[Removing the flywheel cover](#)

- Remove the countershaft from the alternator side.



- Remove the countershaft gear.



- Remove the spacer.



Balancing countershaft fitting

- Install the spacer.



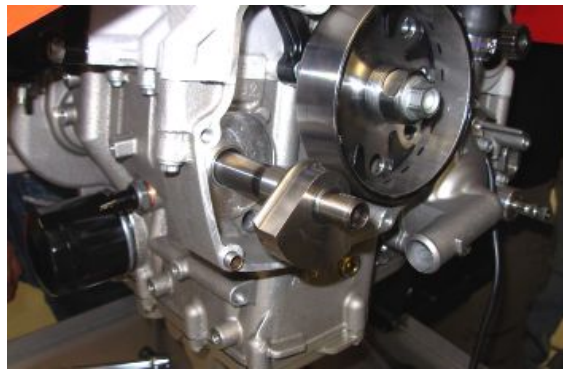
- Install the countershaft gear aligning the references on the countershaft gear and the primary shaft gear.

NOTE

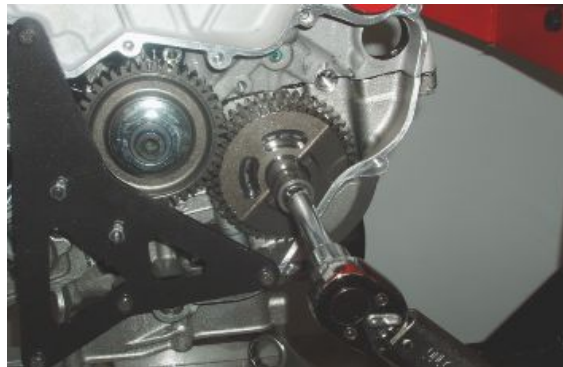
THE BURIN ON THE PRIMARY SHAFT GEAR TOOTH MUST BE INSERTED INTO THE SLOT IDENTIFIED WITH TWO BURINS ON THE COUNTERSHAFT GEAR.



- Insert the countershaft from the alternator side.
- Turn the countershaft until aligning the key seat on the countershaft and on the gear.
- Insert the drive key.



- Turn the nut on the countershaft.
- Block crankshaft rotation using the specific tool.
- Tighten the nut on the countershaft.

**Specific tooling**

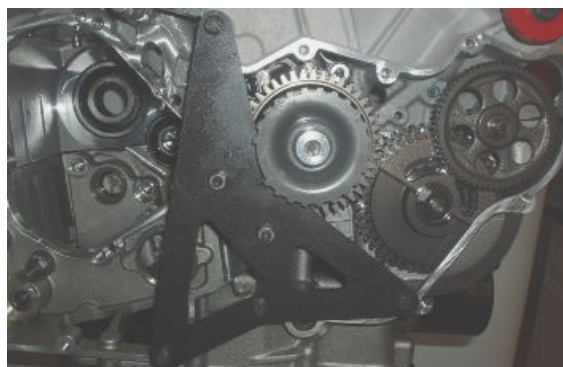
020850Y Primary gear lock

Main transmission gear removal

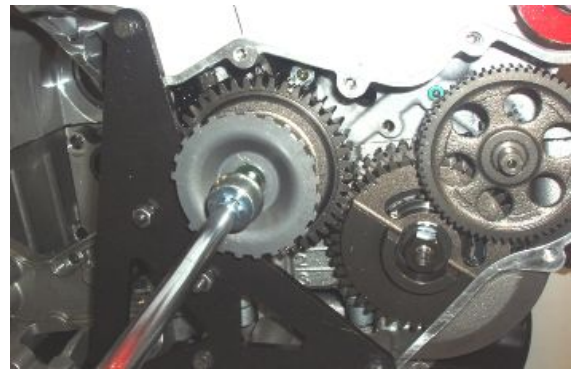
- Remove the clutch.
- Turn the crankshaft and align the references on the countershaft gear and the primary shaft gear.
- Block crankshaft rotation using the specific tool.

Specific tooling

020850Y Primary gear lock



- Unscrew and remove the tone wheel fixing screw.
- Remove the tone wheel.

**See also**

[Disassembling the clutch](#)

- Unscrew and remove the primary shaft fixing nut.
- Remove the crankshaft blocking tool.

Specific tooling

020850Y Primary gear lock

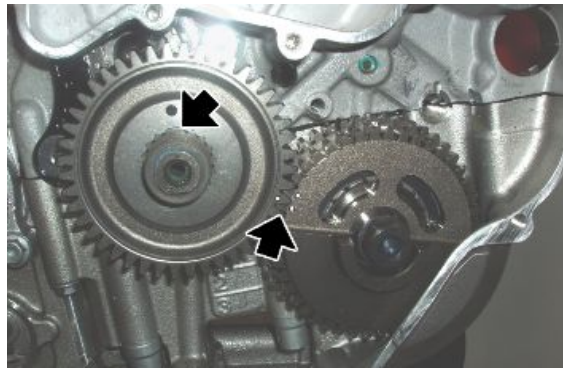


- Remove the primary shaft gear.



Installing the primary drive gear

- Install the primary shaft gear correctly in its seat on the crankshaft from the clutch side.
- Make the references on the gears of the primary shaft and the countershaft coincide.



NOTE

THE BURIN ON THE PRIMARY SHAFT GEAR TOOTH MUST BE INSERTED INTO THE SLOT IDENTIFIED WITH TWO BURINS ON THE COUNTERSHAFT GEAR.

- Install the crankshaft blocking tool.
- Tighten the primary shaft fixing nut.

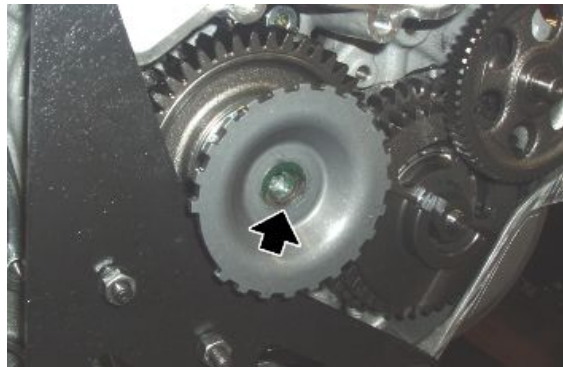
Specific tooling

020850Y Primary gear lock



- Insert the tone wheel on the crankshaft.

The crankshaft and the tone wheel have a bevel that identifies the fitting direction



- Tighten the tone wheel fixing screw.
- Remove the special tool.

Specific tooling

020850Y Primary gear lock



Preparation

To open the crankcase, first remove the following components:

- alternator;
- water pump;
- gearbox unit;
- primary drive shaft gear
- both timing chains;
- the chain sliders;
- oil sump;
- the gear selector pin spacer;
- starter motor and intermediate gear;
- countershaft.

See also

Magneto flywheel removal

Water pump

[Disassembling the gearbox](#)

[Main](#)

transmission gear removal

Front head removal

Rear head removal

[Removing the](#)

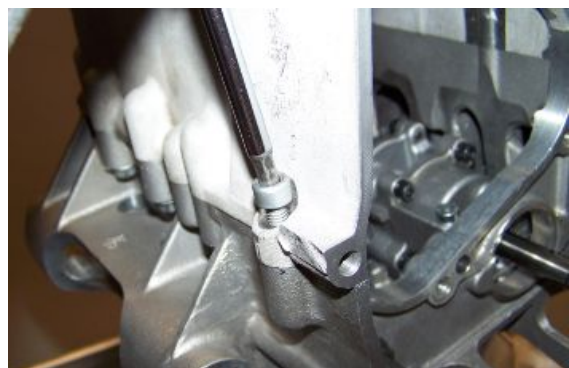
oil sump

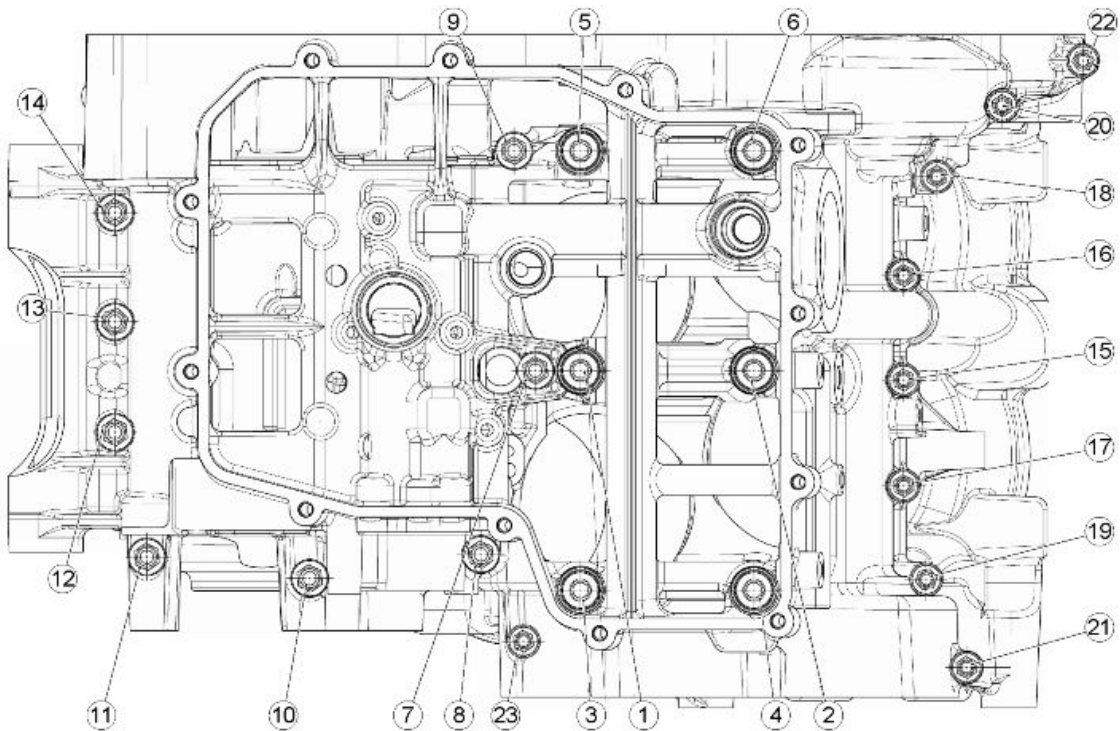
[Balancing](#)

countershaft removal

Crankcase opening

- Position the engine with the heads facing upward, unscrew and remove the screw (24).





- Turn the engine with the heads facing downward and loosen the screws in the following order: 23 - 22 - 21 - 20 - 19 - 18 - 17 - 16 - 15 - 14 - 13 - 12 - 11 - 10 - 9 - 8 - 7.
- After loosening all screws, remove them in order indicated above.
- Loosen the six nuts on the stud bolts, proceeding in the following order 6 - 5 - 4 - 3 - 2 - 1.
- After loosening all nuts, remove them in order indicated above.

- Separate the crankcases, removing the lower part
- Collect the three dowel pins.
- The crankshaft, the pistons and the connecting rods remain in the upper crankcase.



Removing connecting rods - pistons

- Remove both heads.
- Open the crankcases.
- Install the tool that keeps the crankshaft in position.

Specific tooling

020857Y Crankshaft bearing U bolt



See also

Front head removal

Rear head removal

- Unscrew and remove the two connecting rod screws.
- Remove the connecting rod cap.

NOTE

MARK THE COMPONENTS TO PREVENT INCORRECT RE-FITTING.



- Remove the piston connected to the connecting rod from the cylinder side.
- Extract the snap ring, slide off the pin



- Mark the piston crown on the exhaust side so as to remember the refitting position.
- Remove the piston.



Crankshaft removal

- Separate the crankcases, removing the lower part
- If the heads were removed, position the specific special tool to keep the pistons from coming out.

Specific tooling

020858Y Device for holding the pistons in the cylinders

- Unscrew and remove the eight connecting rod screws.
- Remove the four connecting rod caps.

NOTE

MARK THE COMPONENTS TO PREVENT INCORRECT RE-FITTING.



- Take out the crankshaft.



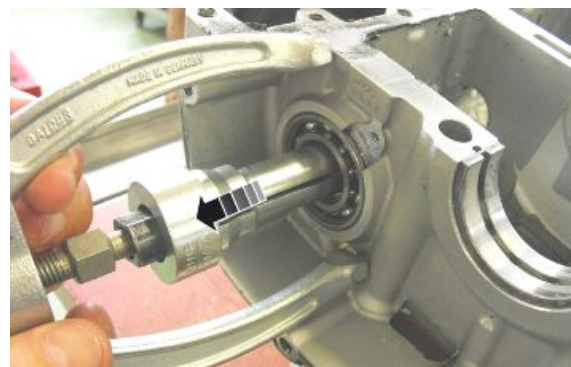
Bearing removal

BALANCING COUNTERSHAFT BEARING REMOVAL

- Remove the lower crankcase.
- Remove the countershaft.

FLYWHEEL-SIDE

- Unscrew and remove the bearing retainer screw.
 - Remove the lock.
-
- Heat up the crankcase to 150°C (302° F)
 - Position the general tool to pull out bearings.
 - Remove the bearing.



See also

Crankcase opening

CLUTCH-SIDE

- Unscrew and remove the bearing retainer screw.
- Remove the lock.



-
- Heat up the crankcase to 150°C (302° F)
 - Position the general tool to pull out bearings.
 - Remove the bearing.



Crankshaft check

Characteristic

Maximum crankshaft axial clearance after closing the crankcase

0.5 mm (0.0197 in)

Maximum radial clearance between the main bearings and the crankshaft pins

0.05 mm (0.00197 in)



Balancing countershaft check

Characteristic

Wear limit (maximum inner diameter) of the countershaft bushings

20.06 mm (0.790 in)

Maximum radial clearance between the countershaft and the relative bushings

0.107 mm (0.0042 in)

Maximum countershaft axial clearance after closing the crankcase

0.1 mm (0.0039 in)

Connecting rod check

Characteristic

Maximum wear limit of the rod small end

17.05 mm (0.671 in)

Maximum rod small end radial clearance

0.055 mm (0.0022 in)

Maximum axial clearance between the connecting rod and the crank pin

0.55 mm (0.022 in)

Maximum connection rod pin clearance

0.08 mm (0.0031 in)



Inspecting pistons

WITHOUT CLASS SELECTION

Characteristic

Minimum piston diameter

77.914 mm (3.067 in)

Maximum clearance between the cylinder and piston

0.1 mm (0.0039 in)

Maximum wear limit of the clearance between pin and pin hole on the piston

0.040 mm (0.0016 in)

Maximum allowed clearance between the first piston ring and respective slot on the piston

0.1 mm (0.0039 in)

Maximum allowed clearance between the second piston ring and respective slot on the piston

0.1 mm (0.0039 in)

Maximum opening of the piston ring fit on the pin First piston ring

0.5 mm (0.0197 in)

Second piston ring

0.7 mm (0.0275 in)

WITH CLASS SELECTION**CAUTION**

THE MEASUREMENT OF THE PISTON DIAMETER IS PERFORMED AT 6 mm (0.24 in) FROM ITS BASE

Characteristic**Piston diameter**

Class A: 77.961-77.971 mm (3.0693-3.0697 in).

Class B: 77.971-77.981 mm (3.0697-3.0701 in)

Maximum clearance between the cylinder and piston

0.1 mm (0.0039 in)

Maximum wear limit of the clearance between pin and pin hole on the piston

0.040 mm (0.0016 in)

Maximum allowed clearance between the first piston ring and respective slot on the piston

0.1 mm (0.0039 in)

Maximum allowed clearance between the second piston ring and respective slot on the piston

0.1 mm (0.0039 in)

Maximum opening of the piston ring fit on the pin First piston ring

0.5 mm (0.0197 in)

Second piston ring

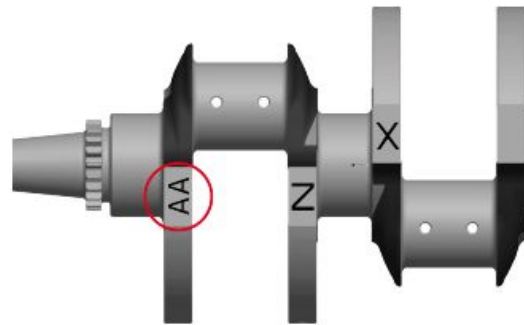
0.7 mm (0.0275 in)

**Selecting connecting rods****SELECTING CRANKSHAFTS AND CONNECTING RODS IN RELATION TO BALANCING CLASS**

On engines equipped with crankshafts with NON extractable sprockets, from engine number:

- V4 A 4382 onwards

crankshafts and connecting rods have been introduced which are matched with each other in relation to their balancing class. The class is easily identifiable as it is marked on the component itself.



CAUTION

IT IS NOT POSSIBLE TO ORDER CERTAIN CONNECTING ROD AND CRANKSHAFTS CLASSES, THEREFORE, IF NECESSARY, REPLACE THE CONNECTING RODS OR CRANKSHAFTS, FOLLOW THE TABLE BELOW.

The permitted crankshaft-connecting rod balancing class combinations are listed in the following table:

CRANKSHAFT-CONNECTING ROD BALANCING CLASSES

Crankshaft balancing classes	Balancing class combinations for alternator side connecting rod pair	Balancing class combinations for primary drive side connecting rod pair
AA	BB+BB	BB+BB
BB *	BB+BB	BB+BB
CC	CC+CC / **BB+DD**	CC+CC / **BB+DD**
DD	DD+DD	DD+DD
EE *	EE+EE	EE+EE
FF	EE+EE	EE+EE

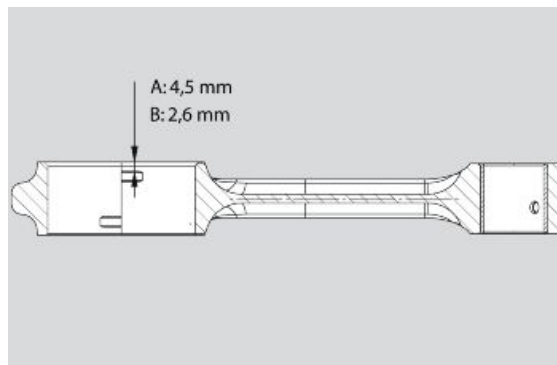
* if necessary replace a crankshaft of a class not available as spare part by keeping the connecting rods in the engine:

- for CRANKSHAFT BB - order CRANKSHAFT AA
- for CRANKSHAFT EE - order CRANKSHAFT FF

CAUTION

THERE ARE TWO TYPES OF CONNECTING RODS THAT CAN BE DISTINGUISHED FOR A DIFFERENT MACHINING IN THE SEATING OF THE BUSHING AND FOR THE TYPE OF BUSHING (THE LENGTH VARIES). THE TWO TYPES OF CONNECTING RODS ARE NOT INTERCHANGEABLE. THE MOTORS MUST BE FITTED WITH FOUR CONNECTING RODS OF THE SAME TYPE.

THE WEIGHT CATEGORIES OF THE CONNECTING RODS AND THEREFORE THE COUPLINGS WITH THE CRANKSHAFTS REMAIN IDENTICAL FOR THE TWO DIFFERENT TYPES OF CONNECTING ROD.

**CAUTION**

WHEN REPLACING A CRANKSHAFT WITH NO IDENTIFIABLE BALANCING CLASS (ON ENGINES PRIOR TO THE INTRODUCTION OF THE MODIFICATION), A CLASS "CC" CRANKSHAFT MAY BE USED.

CAUTION

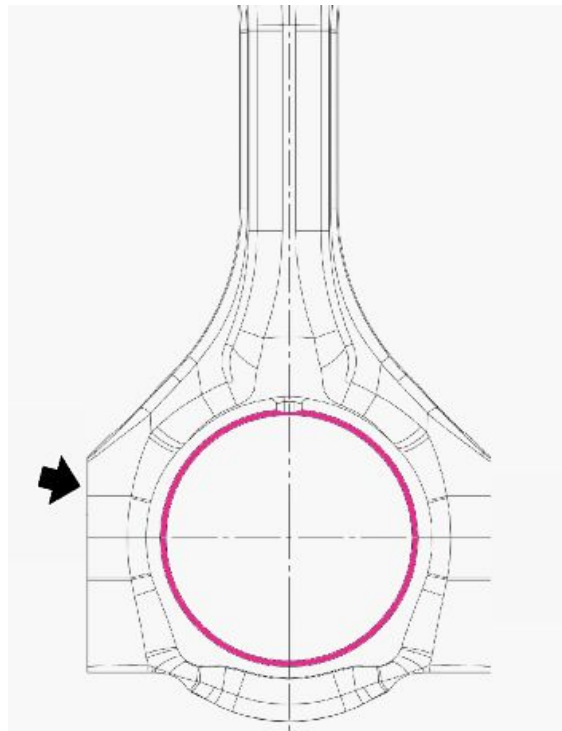
WHEN REPLACING CONNECTING RODS ON CRANKSHAFTS WITH NO IDENTIFIABLE BALANCING CLASS (ON ENGINES PRIOR TO THE INTRODUCTION OF THE MODIFICATION), A CLASS "DD" CONNECTING RODS MAY BE USED.

It is fundamental that, in case of replacement of a connecting rod, also the other one installed on the same crankpin is always replaced:

- if the piston 1 connecting rod is replaced, the one relative to piston 2 must also be replaced and vice versa;
- if the piston 3 connecting rod is replaced, the one relative to piston 4 must also be replaced and vice versa;



The connecting rod class is stamped on its left side, viewed from the front, from the side with the bevelling on the big end hole.



Bushing selection

CRANKSHAFT BUSHINGS

CRANKCASE CATEGORY

Three crankcase classes are available (A - B - C) which differentiate in the diameter of the hole in the bearings.

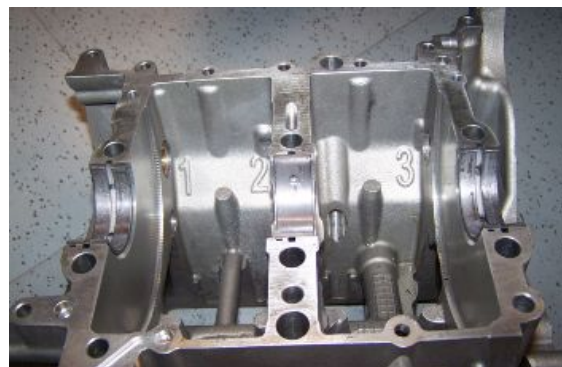
The category is marked on the crankcase, on the right side, in the area below the crankshaft.

Different classes of bearings can be used (e.g.: A - B - C or B - B - C or A - B - A).



A number that indicates the position of the main journal is stamped on the crankcase:

1. flywheel side;
2. central;
3. clutch side



CRANKCASE CATEGORY

Specification	Desc./Quantity
Class A	Bushing seat diameter 52.023 - 52.018 mm (2.0481 - 2.0479 in)
Class B	Bushing seat diameter 52.018 - 52.013 mm (2.0479 - 2.0477 in)
Class C	Bushing seat diameter 52.013 - 52.008 mm (2.0477 - 2.0475 in)

SHAFT CATEGORY

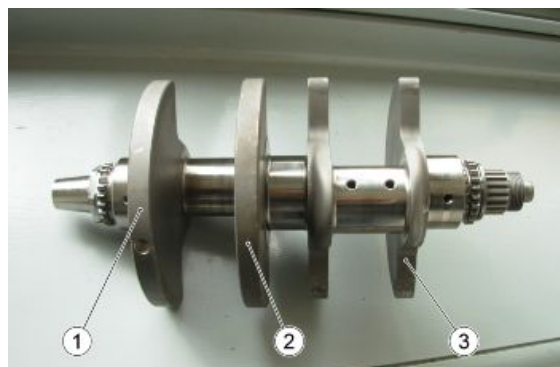
The three crankshaft main journals

1. flywheel side;
2. central;
3. clutch side

they are each selectable in two pairs of classes, A-B (up to engine No. 3990) or C-D-E (from Engine No. 3991).

The class is stamped on the flat face of the counterweight, as shown in the image.

The three main journals may have different classes to each other according to the type of coupling (e.g. A - B - A or B - B - A etc.) or (e.g.: C - D - E or D - C - C etc.)

**CRANKSHAFT CATEGORY UP TO ENGINE No. 3990**

Specification	Desc./Quantity
Class A	Main journals - diameter: 46,005 - 46,000 mm (1,8112 - 1,8110 in)
Class B	Main journals - diameter: 46,000 - 45,995 mm (1,8110 - 1,8108 in)

CRANKSHAFT CATEGORY FROM ENGINE No. 3991

Specification	Desc./Quantity
Class C	Main journals - diameter: 46,008 - 46,003 mm (1,8113 - 1,8111 in)
Class D	Main journals - diameter: 46,003 - 45,998 mm (1,8111 - 1,8109 in)
Class E	Main journals - diameter: 45,998 - 45,993 mm (1,8109 - 1,8107 in)

Once the categories below are checked:

1. crankcase;
2. flywheel side main journal;
3. centre main journal;
4. clutch side main journal.

Choose the bushings used for assembly from the following table

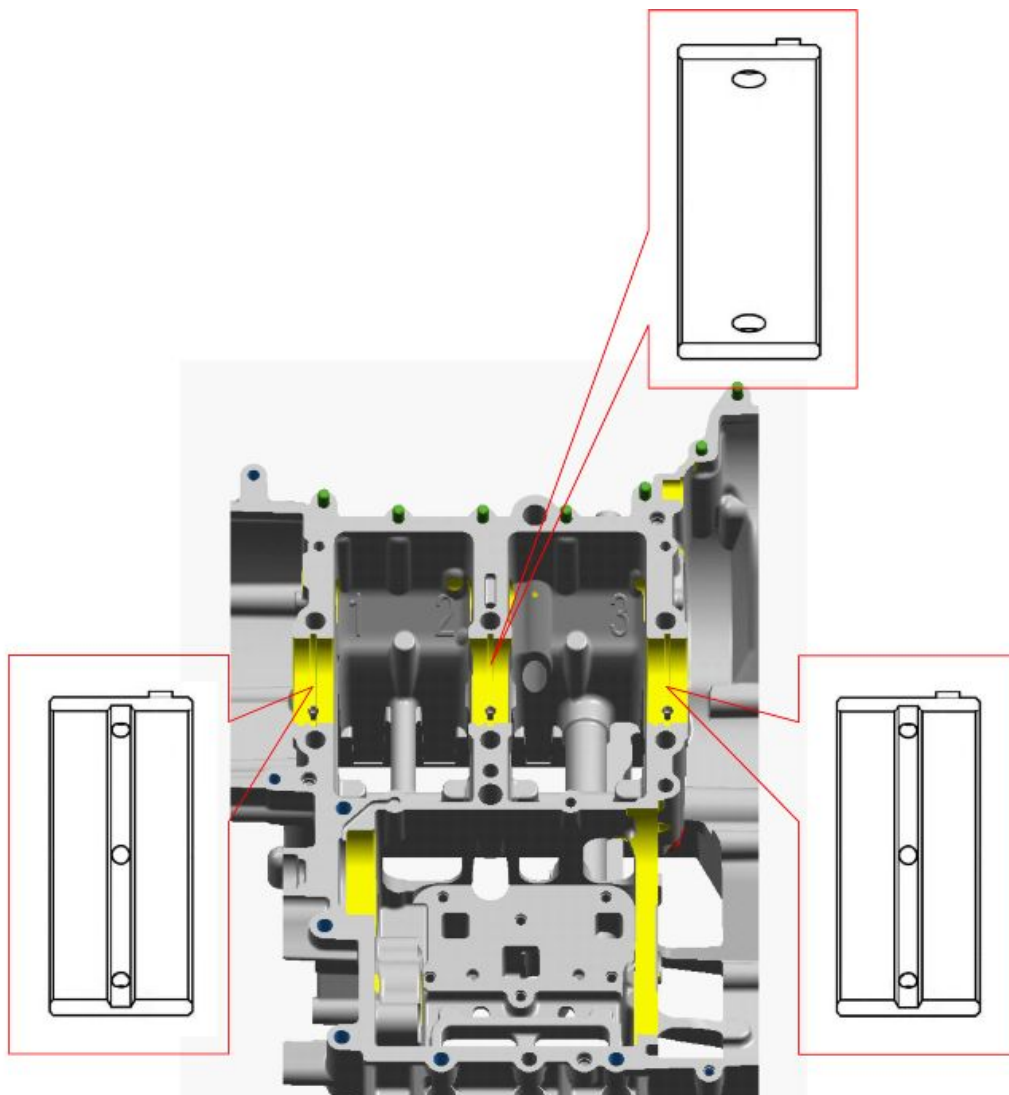
CRANKSHAFT BUSHINGS UP TO No. 3990

Crankshaft main journal	Class A crankcase	Class B crankcase	Class C crankcase
Class A main journal	Bushing (blue)	Bushing (blue)	Bushing (red)
Class B main journal	Bushing (yellow)	Bushing (blue)	Bushing (blue)

CRANKSHAFT BUSHINGS FROM No. 3991

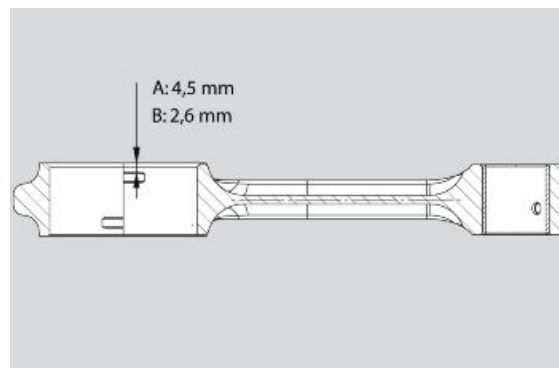
Crankshaft main journal	Class A crankcase	Class B crankcase	Class C crankcase
Class C main journal	Bushing (blue)	Bushing (red)	Bushing (red)
Class D main journal	Bushing (blue)	Bushing (blue)	Bushing (red)
Class E main journal	Bushing (yellow)	Bushing (blue)	Bushing (blue)

The flywheel side and clutch side main bearings are different from the central ones and therefore, so are the respective replacement part numbers.



CRANKSHAFT BUSHINGS - CONNECTING RODS

There are two different connecting rod types distinguished by the operation practised on the semi-bushings seat.

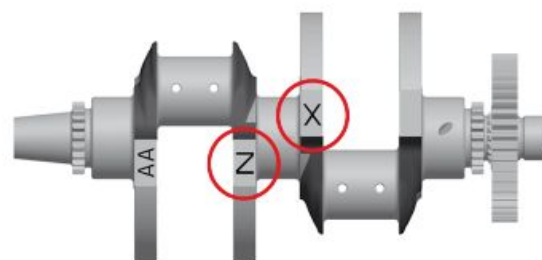


For the type "A" connecting rod, three types of semi-bushings are available:

- Red
- Blue
- Yellow

For the coupling of the connecting rod with the crankshaft, coupling classes are not indicated, but in alternative the two following semi-bushings are available:

1. BLUE - BLUE (recommended solution)
2. YELLOW - RED (if combination is not possible)



In combination 2, the YELLOW semi-bushing must be installed on the connecting rod shank and the RED semi-bushing must be installed on the cap.

For the type "B" connecting rods, three types of semi-bushings are available:

- Blue
- Yellow
- Green

For the coupling of the connecting rod with the crankshaft, according to the engraving on the counterweights, observe the following table:

CONNECTING ROD COUPLING "TYPE 2" - CRANKSHAFT

Selection connecting rod pin dimension	Connecting rod pin dimension	Bushing colours	Provided clearance
X	39.008 - 39.003 mm	Blue + Yellow	0.054 - 0.026
Y	39.003 - 38.998 mm	Yellow + Yellow/ *Blue + Green*	0.054 - 0.026
Z	38.998 - 38.992 mm	Yellow + Green	0.055 - 0.026

key:

* Selection of colours that can be fitted as an alternative to the main selection

BIG END BUSHING REPLACEMENT PROCEDURE

When replacing the big end bushings, make sure that the tang of the semi-bushing is correctly housed in the corresponding notch in the connecting rod stem or cap.



Bearing fitting

BALANCING COUNTERSHAFT BEARING INSTALLATION FLYWHEEL-SIDE

- Heat up the crankcase to 150°C (302°F).
- Prepare the following tools:

Specific tooling

020364Y 25 mm Adaptor

020359Y 42 x 47 mm punch

020376Y Adapter handle

- Position the new bearing with its groove on the outside diameter facing outward with respect to the crankcase. In this way it will be possible to install the bearing retainer in the groove.



-
- Using the suitable tools, fit the bearing in the crankcase until tool stops



-
- Fit the retainer in the bearing groove.
 - Tighten the bearing retainer screw.



CLUTCH-SIDE

- Heat up the crankcase to 150°C (302°F).
- Prepare the following tools:

Specific tooling

020363Y Crankshaft oil seal punch D 20 mm

020359Y 42 x 47 mm punch

020376Y Adapter handle

-
- Position the new bearings with their groove on the outside diameter facing outward with respect to the crankcase. In this way it will be possible to install the bearing retainer in the groove.



- Using the suitable tools, fit the bearing in the crankcase until tool stops.



- Fit the retainer in the bearing groove.
- Tighten the bearing retainer screw.
- Install the balancing countershaft.



Crankshaft fitting

NOTE



ACCORDING TO THE TYPE OF CRANKSHAFT, ITS INSTALLATION WILL FOLLOW TWO DIFFERENT PROCEDURES ("OPTION 1" AND "OPTION 2").

OPTION 1

Crankshaft with removable gear.

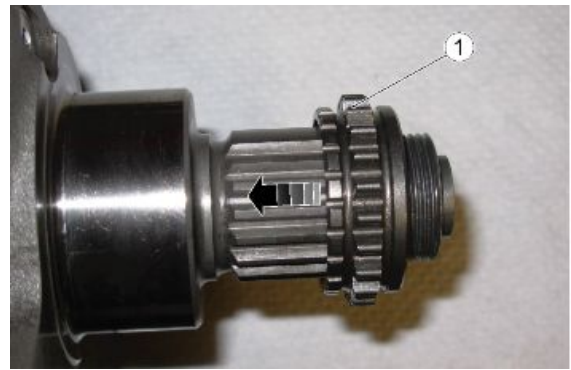
If the two timing chain control sprockets (1 - 2) on the crankshaft were removed, check their exact positioning carefully because the two components cannot be interchanged.

Remember that the thicker sprocket (1) must be positioned from the clutch side of the crankshaft.



Position the sprocket (1) with the smooth side facing outward of the crankshaft.

Move the sprocket (1) up against the crankshaft shoulder.



- Lubricate the crankshaft pins and insert them into their positions.



- Install the connecting rod shank piston assembly in the relative cylinders.
- Join the crankcases.
- If the special tool was used, remove it to keep the pistons from coming out.

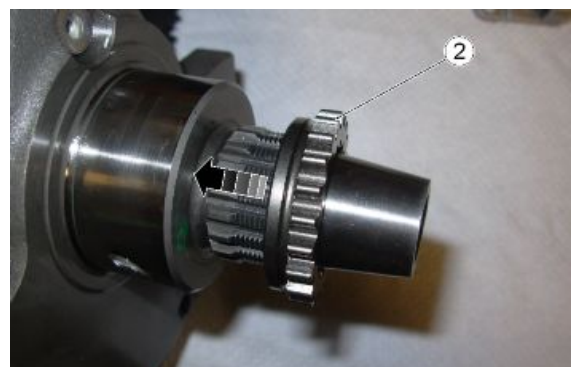


Specific tooling

020858Y Device for holding the pistons in the cylinders

Position the sprocket (2) with the smooth side facing the inside of the crankshaft.

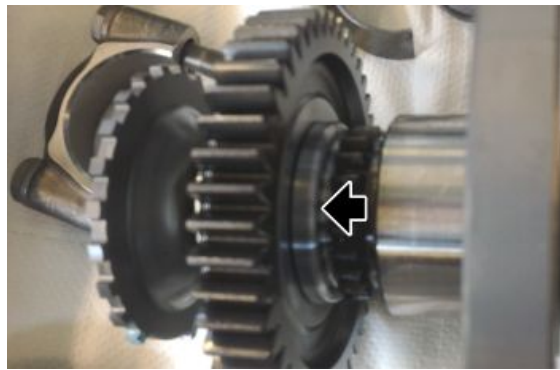
Move the sprocket (2) up against the crankshaft shoulder.



OPTION 2

Crankshaft with non removable gear.

When refitting the primary gear, remember to first place the lining as shown in the figure. The greater diameter side is facing outwards the engine.



- Install the primary shaft gear correctly in its seat on the crankshaft from the clutch side.
- Make the references on the gears of the primary shaft and the countershaft coincide.



NOTE

THE BURIN ON THE PRIMARY SHAFT GEAR TOOTH MUST BE INSERTED INTO THE SLOT IDENTIFIED WITH TWO BURINS ON THE COUNTERSHAFT GEAR.

- Install the crankshaft blocking tool.
- Tighten the primary shaft fixing nut.



Specific tooling

020850Y Primary gear lock

- Insert the tone wheel on the crankshaft.

The crankshaft and the tone wheel have a bevel that identifies the fitting direction



- Tighten the tone wheel fixing screw.
- Remove the special tool.



Specific tooling

020850Y Primary gear lock

Installing connecting rods - pistons

CAUTION

(*) REPLACE PISTONS THUS MARKED "A" "B" AT THE SAME TIME. THE NEW DETAILS WILL NO LONGER BE 'MARKED "A" "B", BUT WITH THE CODE "AW" "BW"

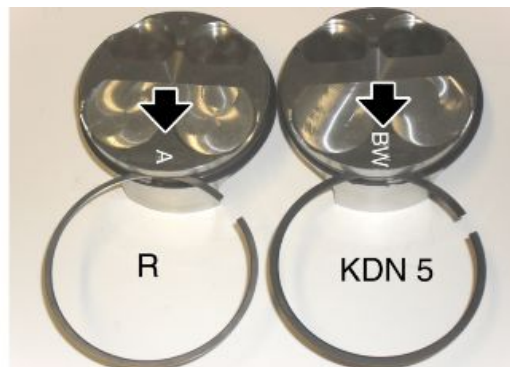
PISTONS AND PISTON RINGS COUPLING

Model	Engine No.	Crankcase selections	Piston type	Piston ring
MY 2009/2010 - "V4" Marking (all engines)	from 1006 to 9269	NO	without marking	Chrome steel band
EUROPE MY2011 - "V4" Marking (all engines)	from 8001 to 8588	YES	with "A" or "B" marking (*)	Chrome steel band
EUROPE MY2011 - "V4-A" Marking	from 1159 to 1346	YES	with "AW" or "BW" marking	Cast iron band
EUROPE MY2011 - "V4-A" Marking	from 1455 to 2110	YES	with "A" or "B" marking (*)	Chrome steel band
EUROPE MY2011 - "V4-A" Marking	from 2111 onwards	YES	with "AW" or "BW" marking	Cast iron band
USA MY2011 - "V4-A" Marking	all engines	YES	with "AW" or "BW" marking	Cast iron band

The piston rings are different and must be fitted with the markings "R" or "KDN5" (for the upper one) and "RN" (for the lower one) facing upward.

The upper ring can be of a different type according to the type of piston used.

The pistons with the letter "W" on the crown next to the selection marking (A or B), fit an upper ring (cast iron) different from the pistons that do not have this marking (chrome steel). This ring can be identified with the code "KDN 5" which, when fitting, must be placed upwards.

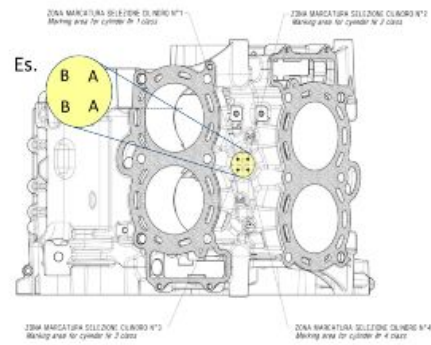


CAUTION

THE TWO RINGS ("R" AND "KDN5") CANNOT BE INTERCHANGED, THE PISTONS WITH MARKING "W" HAVE A DEEPER SEAT FOR THE FIRST RING, WHICH IS WHY THEY CANNOT BE INTERCHANGED.

The five ring gaps (two piston rings, two oil scraper rings, one oil scraper spring) are fitted displaced 90° to each other, starting from the exhaust side stud bolt opposite the chain and continuing clockwise.

The fitted pistons have two selections A and B. Therefore they are coupled with the cylinder according to the selection of the latter, which is marked on the upper crankcase halves.



NOTE

THERE ARE THREE TYPES OF PISTON MARKINGS ON THE ENGINE:

- PISTON WITHOUT MARKING.
- PISTON WITH MARKING "A" OR "B".
- PISTON WITH MARKING "AW" OR "BW".

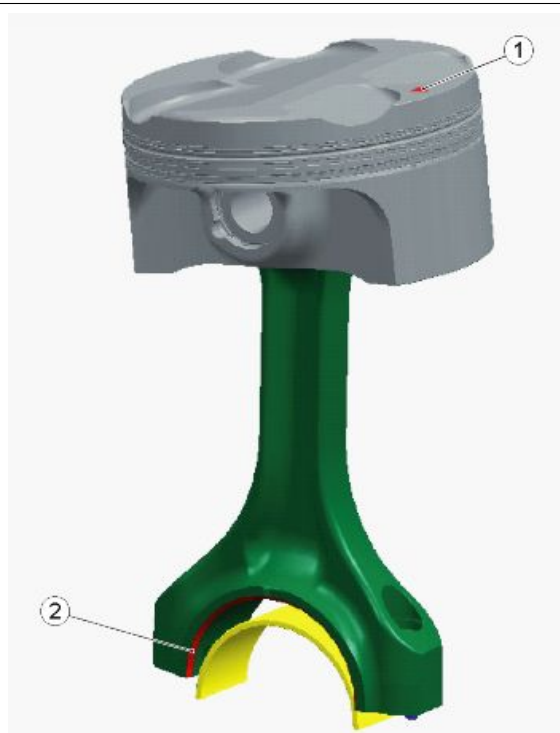
ACCORDING TO THE TYPE OF PISTON MARKING, SELECT THE CORRESPONDING RING.



Preassemble the pistons on the workbench with the connecting rod shank and the respective semi-bushing.

The pre-assembly procedure is identical for all four pistons and must be done as follows:

- with the piston crown parallel to the workbench and the arrow (1) positioned from the side opposite of the operator, fit the connecting rod shank with the bevelling (2), on the hole of the big end, on the right side.



- Position the special tool on the crankcase.
- Partially insert the connecting rod shank - piston assembly in the corresponding cylinder with the arrow (on the piston) twisted 45° towards the exhaust.
- When the connecting rod head is low, and has exceeded its lubricating jet, rotate the connecting rod shank - piston assembly with the arrow on the piston crown towards the exhaust; the beveling on the connecting rod head must face outward of its crank pin.



Specific tooling

020856Y Piston installation ring

- Remember to couple the connecting rod shank and cap correctly, combining the respective numerical references.
- Use new connecting rod screws, lubricating the thread and under the head..



- Proceed with tightening according to the procedure described in the tightening torque table using the torque wrench and angular tightening with a goniometer.



Crankcase closing

- Insert the crankshaft together with connecting rods and pistons in the upper crankcase.
- Position the three centring dowels in the crankcase.
- Insert a new oil seal O ring in the specific seat.



- Apply a layer of sealing paste along the external edge of the crankcase.
- Join the two crankcases.



Recommended products

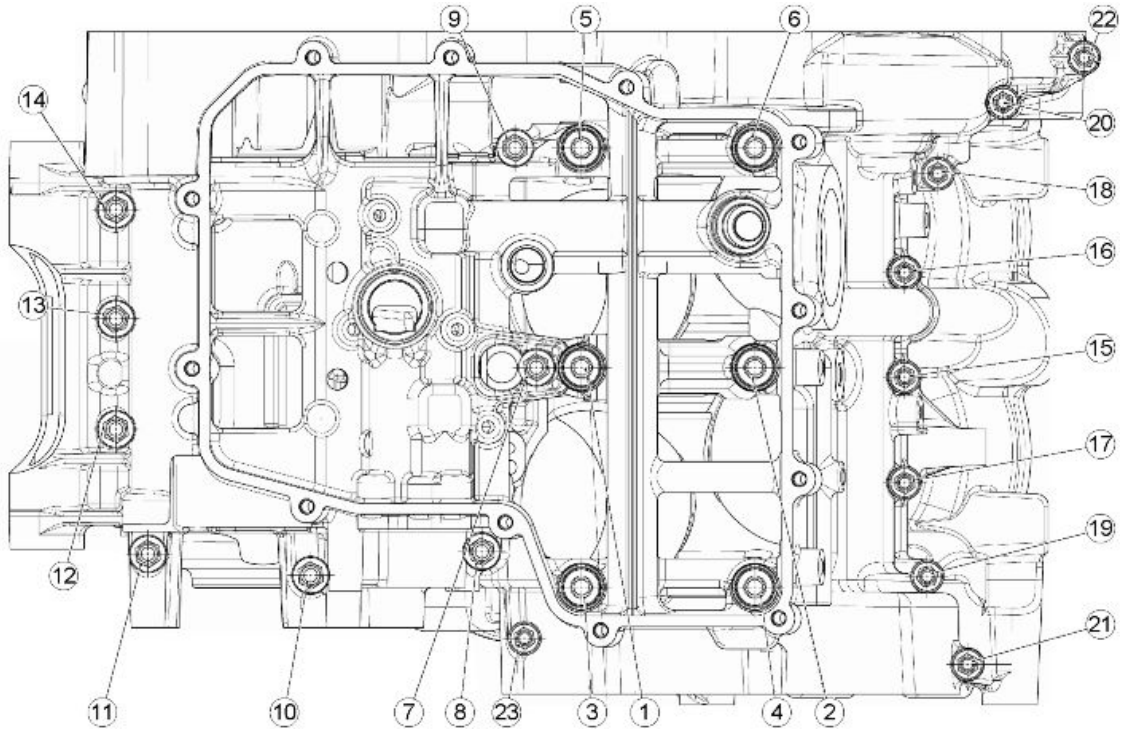
Three bond Sealing paste

-

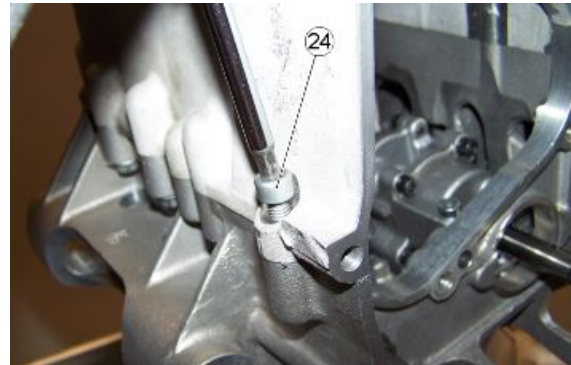


- Pretighten the six nuts on the stud bolts proceeding in the following order: 1 - 2 - 3 - 4 - 5 - 6.

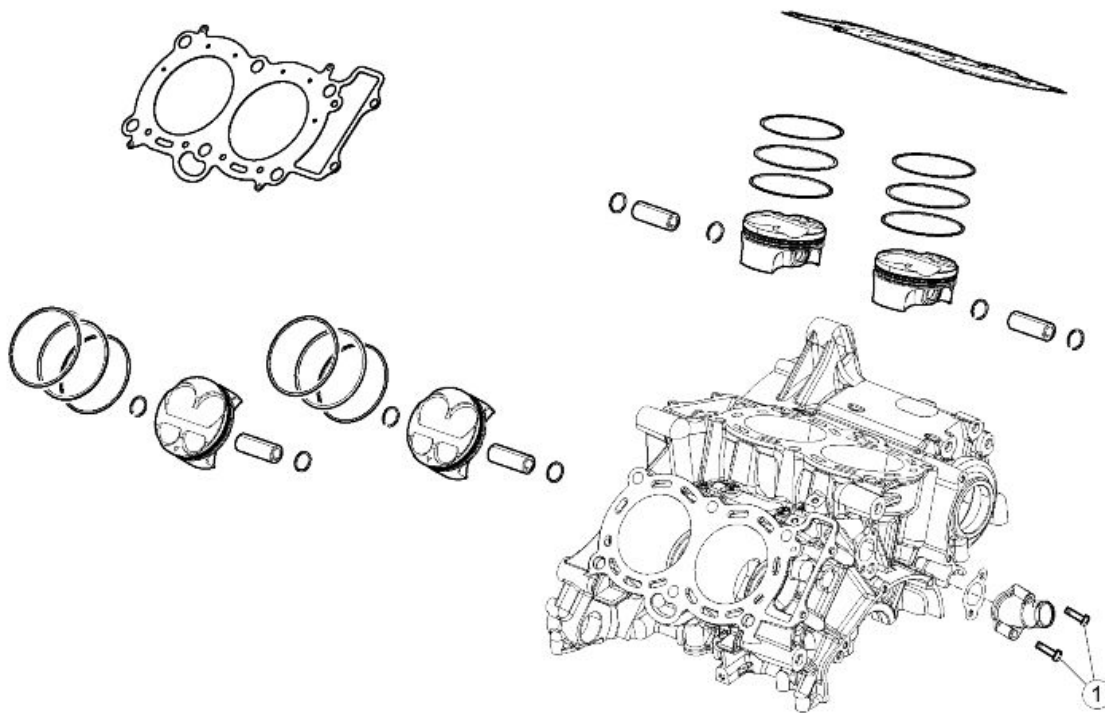
- Then tighten them fully following the same order.
- Pre-tighten the screws in the following order: 7 - 8 - 9 - 10 - 11 - 12 - 13 - 14 - 15 - 16 - 17 - 18 - 19 - 20 - 21 - 22 - 23.
- Then tighten them fully following the same order.



- Turn the engine with the heads facing upward.
- Tighten the screw (24).



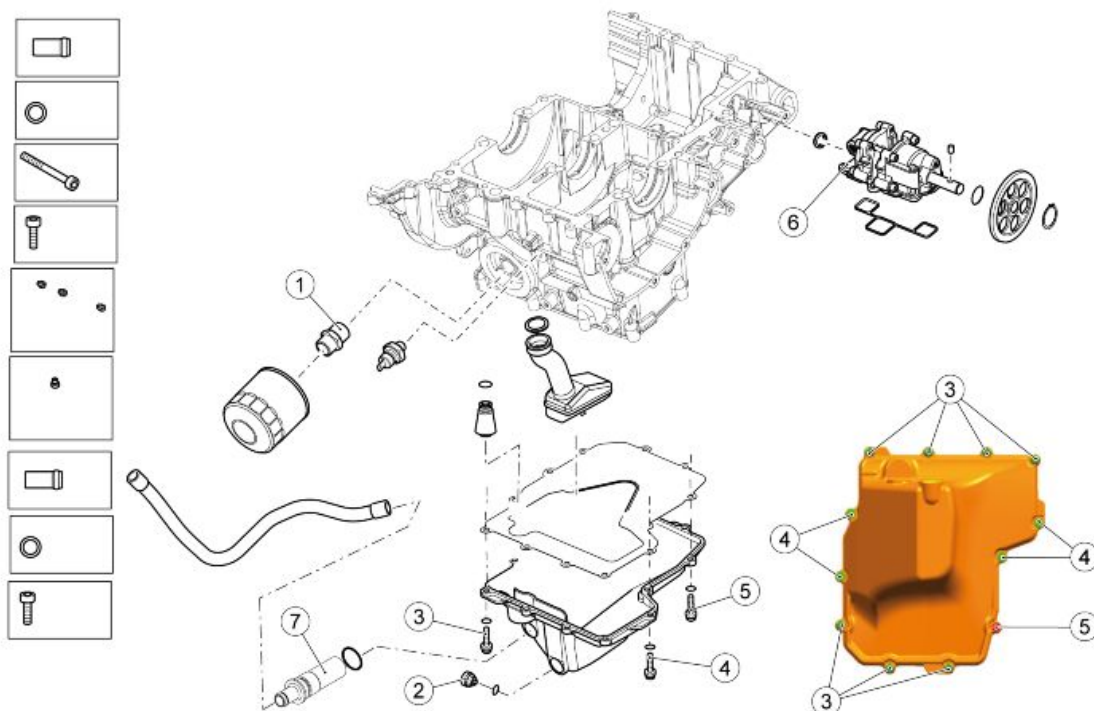
Thermal group



CYLINDERS - PISTON

pos.	Description	Type	Quantity	Torque	Notes
1	Screws fastening water union onto crankcase	M6x40	2	10 Nm (7.37 lbf ft)	-

Lubrication

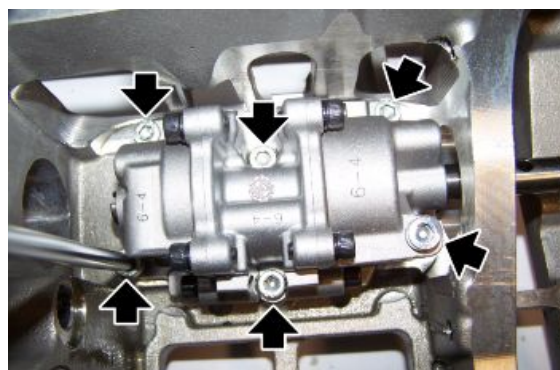


LUBRICATION

pos.	Description	Type	Quantity	Torque	Notes
1	Oil filter union fixing screw	-	1	30 Nm (22.13 lbf ft)	-
2	Oil drainage plug	-	1	30 Nm (22.12 lbf ft)	-
3	Oil sump fixing screws	M6x30	7	12 Nm (8.85 lbf ft)	-
4	Oil sump fixing screws	M6x22	4	12 Nm (8.85 lbf ft)	-
5	Oil sump fixing screws	M6x25	1	12 Nm (8.85 lbf ft)	-
6	Screws fastening the pump to the crankcase	M6	5+1	10 Nm (7.37 lbf ft)	-
7	Oil pipe union fixing screw	M6	1	8 Nm (5.90 lbf ft)	Loct. 243
-	Screw fastening the diffuser in the oil sump	-	1	10 Nm (7.37 lbf ft)	-

Oil pump**Removing**

- Remove the gearbox.
- Remove the water pump.
- Unscrew and remove the six screws fastening the oil pump to the crankcase.
- Remove the oil pumps.

**OIL PUMP REMOVAL**

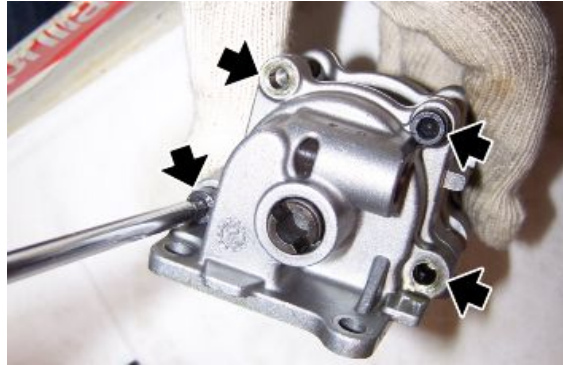
- Place the oil pumps on a work table.
- Remove the gasket.

**See also**

[Removing the gearbox](#)

Water pump

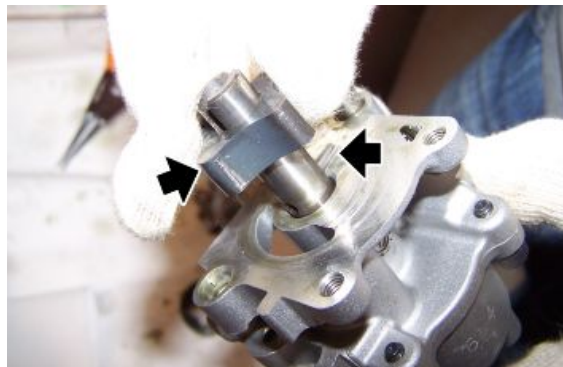
- Unscrew and remove the four cooling oil pump cover screws



- Remove the cooling oil pump cover.
- Collect the two dowel pins.
- Remove the external rotor from the cover.



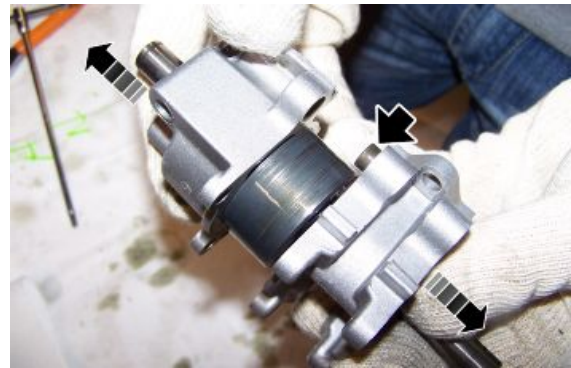
- Remove the internal oil cooling rotor.
- Collect the hitch pin.



- Unscrew and remove the four lubrication oil pump cover screws.



- Remove the lubrication oil pump cover and the intermediate pump casing from the shaft.
- Collect the two dowel pins.



- Remove the external lubrication rotor.



- Remove the internal oil lubrication rotor
- Collect the drive spindle.



Installing

- Position the lubrication pump internal rotor on the oil pump control shaft

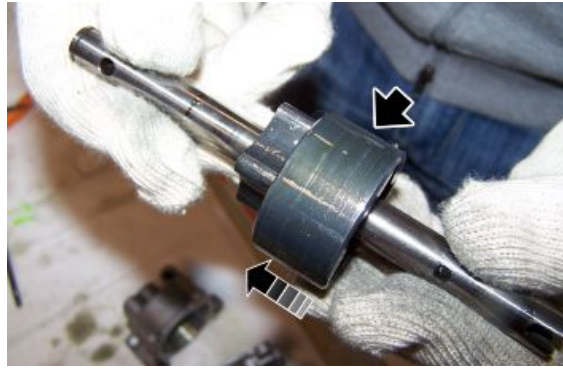
The lubrication pump components are larger than the cooling pump components.

The lubrication pump must be fit onto the shaft from the side with the Seeger ring seat for fastening the gear.

- Install the drive spindle on the shaft.



- Position the external rotor on the lubrication pump's internal rotor.



- Position the dowel pins.
- Position the pump cover and the intermediate pump casing on the lubrication pump's external rotor.

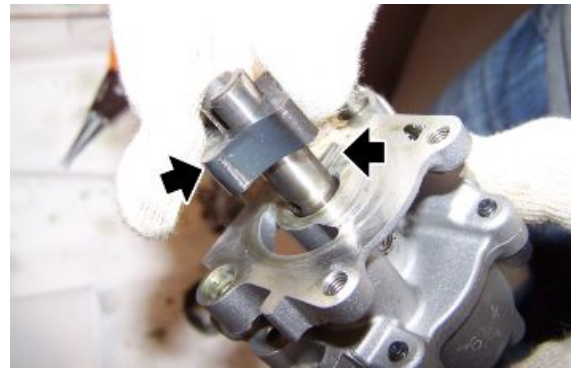
To check that the intermediate casing is oriented correctly, check the gasket seat.



- Tighten the four lubrication oil pump cover screws.



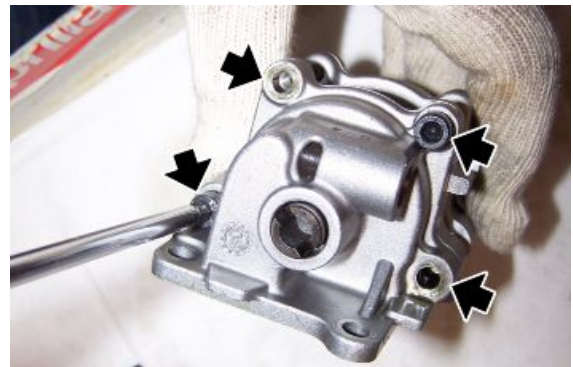
- Position the hitch pin on the oil pump control shaft.
- Position the oil cooling pump's internal rotor.



- Position the dowel pins and the external rotor on the cooling oil pump cover.
- Fit the pump cover on the internal rotor.

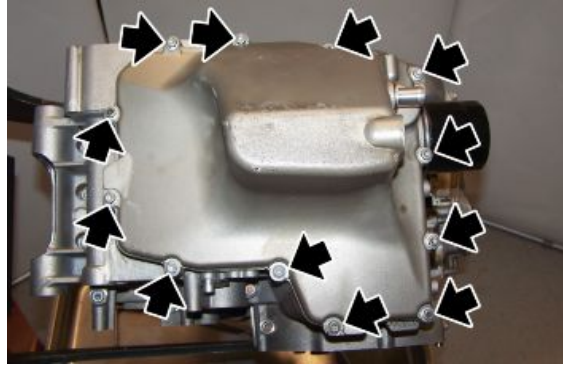


- Tighten the four cooling oil pump cover screws.
- Fit a new gasket.



Removing the oil sump

- Drain the engine oil.
- Unscrew and remove the twelve oil sump screws.



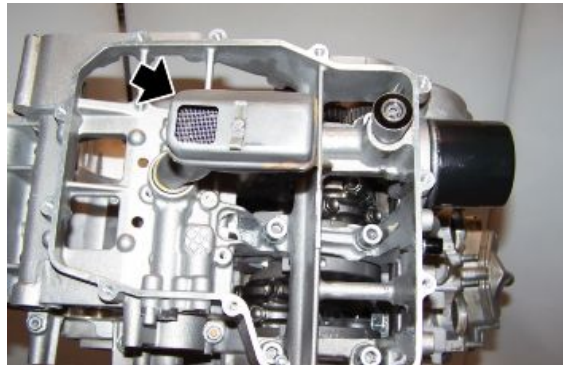
- Remove the oil sump.
- Remove the metal gasket.



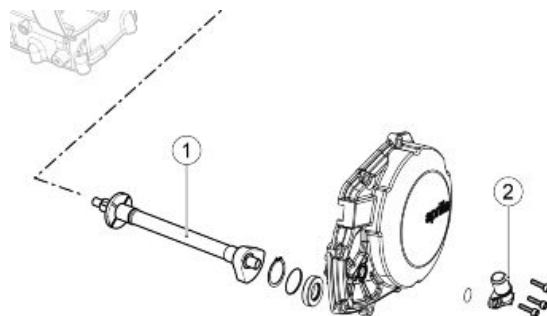
- Remove the rose pipe together with the gasket.



DURING REFITTING REPLACE THE GASKET WITH A NEW ONE OF THE SAME TYPE.



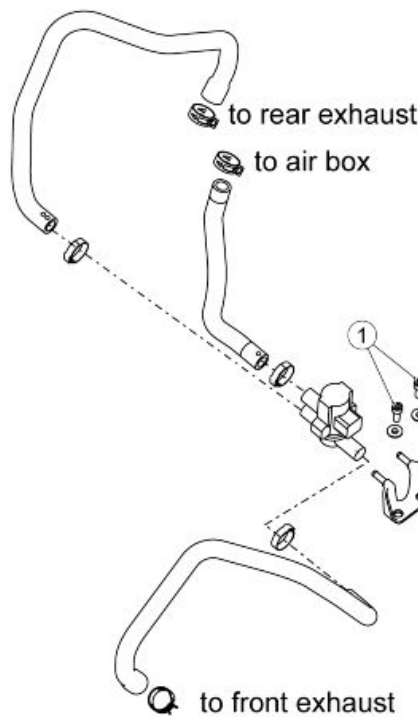
Blow-by



The Blow-by system uses the rotation of the countershaft (1) to separate the engine oil into oil vapour and liquid.

The oil vapours exit from the fitting (2) on the alternator cover and enter the air filter box whereas the liquid returns to the oil sump.

SAS valve



SECONDARY AIR SYSTEM

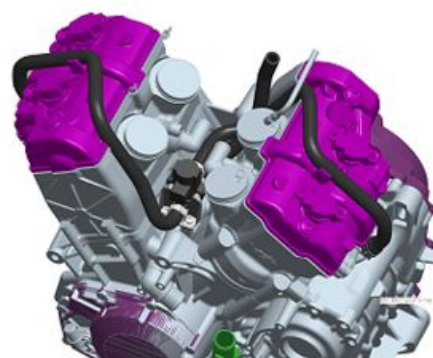
pos.	Description	Type	Quantity	Torque	Notes
1	Secondary air system solenoid screws	-	2	10 Nm (7.37 lbf ft)	-

Diagram

Valve controlled by control unit which delivers aspirated air from the filter box to the exhaust manifolds.

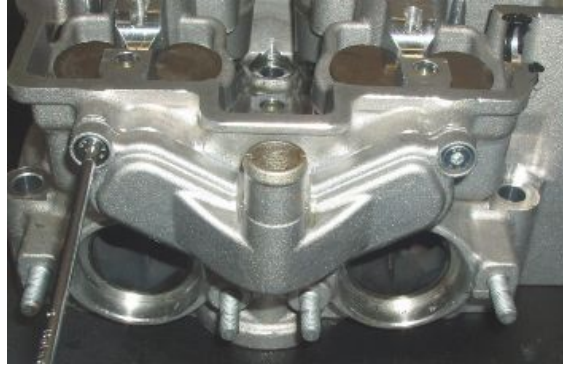
The advantages of this function are twofold:

- the catalytic converter reaches the operating temperature more quickly;
- it permits the use of richer mixtures in some critical conditions (e.g. at idle or low engine speeds).



Inspecting the one-way valve

- Unscrew and remove the three screws.



- Remove the cover together with the two secondary air system valves.



INDEX OF TOPICS

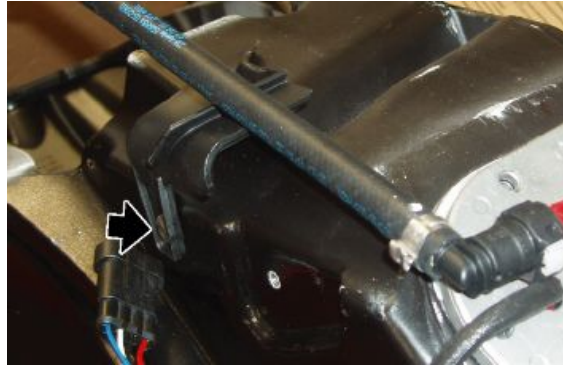
POWER SUPPLY

P SUPP

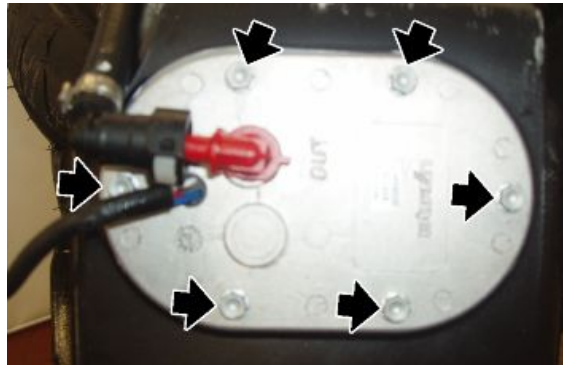
Fuel pump

Removing

- Remove and empty the fuel tank.
- Loosen the pipe grommet screw.
- Detach the fuel pipe.

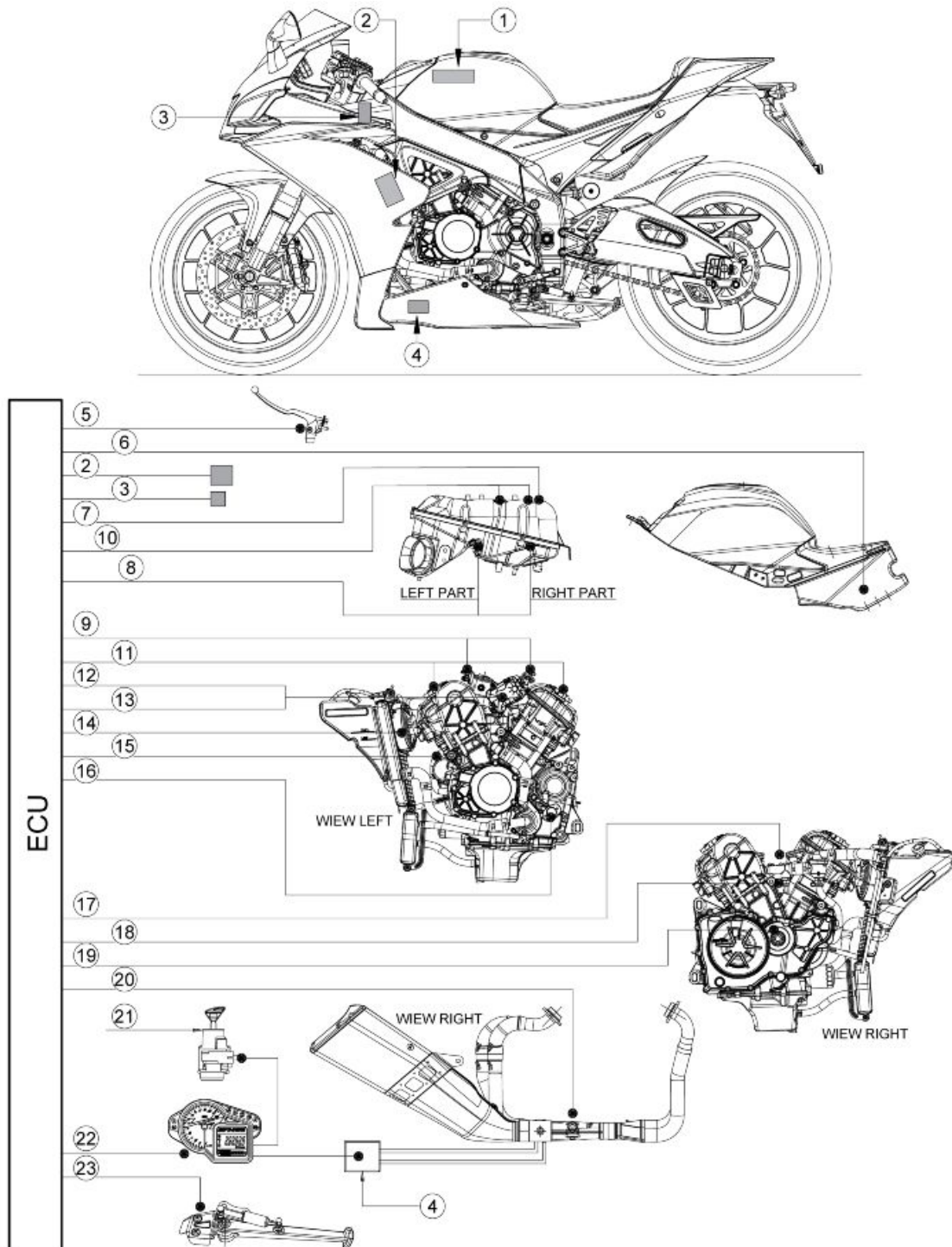


- Unscrew and remove the screws.
- Remove the fuel pump.



Injection

Diagram



key:

- 1. Control unit position
- 2. Hand grip position sensor
- 3. Fall sensor
- 4. Outlet valve

5. Clutch position sensor
 6. Fuel pump (inside the tank)
 7. Air temperature sensor
 8. Air pressure sensor (MAP)
 9. Lower injectors
 10. Upper injectors
 11. Coils (spark plug cover)
 12. Engine throttle valves
 13. Throttle valve position sensor
 14. Electric fan
 15. Starter motor
 16. Gear position sensor
 17. Secondary air injection valve
 18. Coolant temperature sensor
 19. Crankshaft position sensor
 20. Oxygen sensor
 21. Ignition switch
 22. Instrument panel
 23. Side stand sensor
-

Ride by Wire

Operating logic

Those riding motorbikes do not require a specific throttle valve opening from their engines but actually a specific torque. The Ride by Wire system has been so designed that the throttles of the throttle bodies are mechanically isolated from the throttle control; their actuation depends exclusively on 2 electrical motors controlled by the control unit. The control unit refers to specific handle maps to determine by how much and how quickly the throttle valves are opened. The parameters influencing the handle map are as follows:

- Handle aperture
- Engine rpm
- Handle aperture rate

The Marelli control unit performs the following functions:

1. Implements the necessary strategies for calculating torque demand
 2. Operates the sensors and actuators necessary for system function
 3. Safety checks for the Ride by Wire system
-

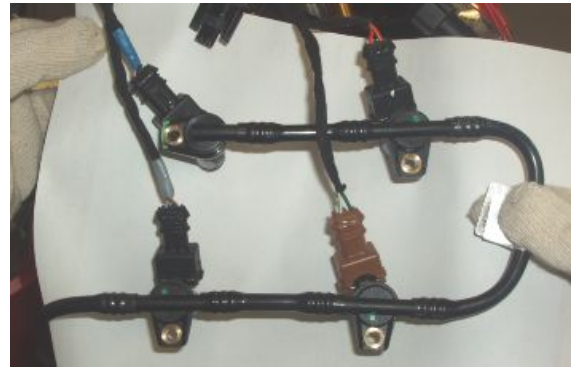
Removing the injector

To optimise engine performance, there are four lower injectors on the throttle bodies and four upper injectors on the filter box. Except during transition stages, only the lower or the upper injectors are working at any given time.

- The lower injectors optimise tractability and reduce emissions and fuel consumption
- The upper injectors are designed for maximum power output and, as a result, have a high fuel flow rate

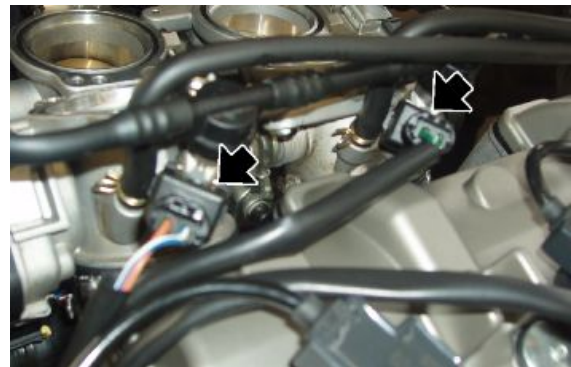
The electrical connectors are colour coded as follows to prevent accidentally swapping the injector connectors:

- Cylinder 1: Black
- Cylinder 2: Brown
- Cylinder 3: Green
- Cylinder 4: Grey



LOWER INJECTORS

- Remove the air filter box.
- Disconnect the injector connectors.



- Unscrew and remove the injector fixing screws.
- Remove the lower injectors, identified by grey collars.

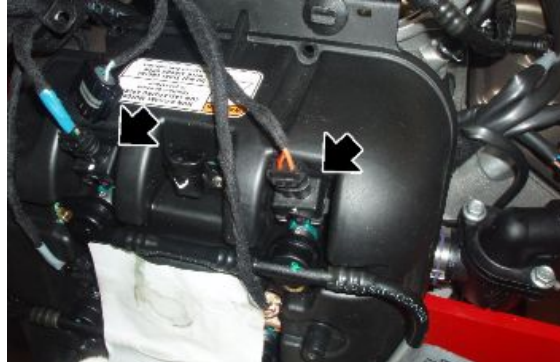


See also

[Air box](#)

UPPER INJECTORS

- Remove the control unit.
- Disconnect the injector connectors.



- Unscrew and remove the injector fixing screws.
- Remove the upper injectors, identified by green collars.

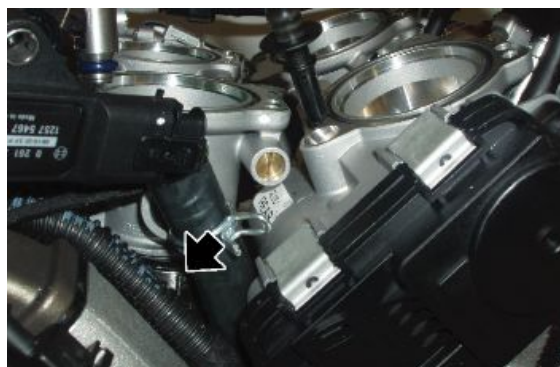
**See also**[Control unit](#)

Removing the throttle body

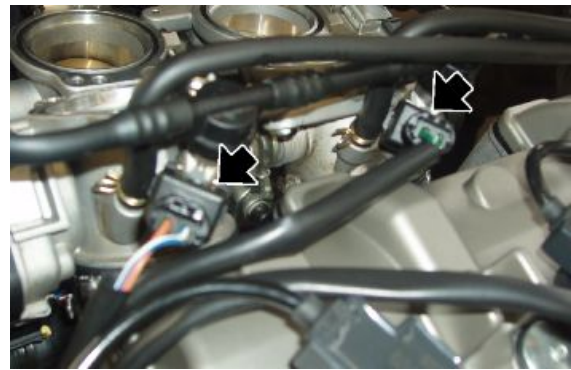
- Completely remove the air filter box.
- Disconnect the injector fuel pipe.
- Release the snap fit clamp on the collars from the engine.

NOTE

DO NOT RELEASE THE CLAMPS COMPLETELY. LEAVE IN AN INTERMEDIATE POSITION TO FACILITATE REFITTING.



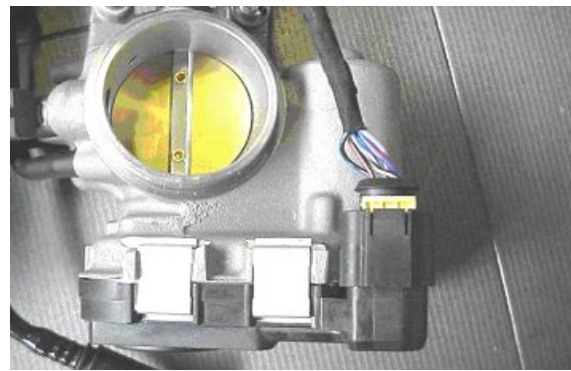
- Disconnect the lower injector connectors.



See also

[Air box](#)

- Disconnect the connector.
- Remove the complete throttle body.



Checking the throttle body

The throttle bodies are maintenance free and are not serviceable. Replace the entire assembly in the event of malfunction.

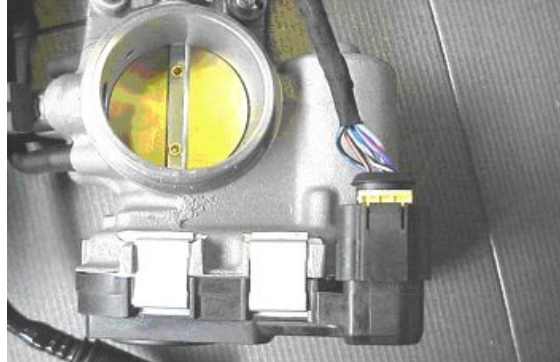
As all the internal components of the throttle body assembly (potentiometers and electrical motor) are contactless, no electrical diagnosis is possible. Functional tests are performed on the throttle body assembly by the control unit during vehicle operation, with the results visible on the diagnostic instrument.

The only action possible before replacing the component is checking the connectors and cable harnesses.



Installing the throttle body

- When installing the throttle body, refer to the electrical system section for the correct cable routing.
- Ensure that the injector connectors are correctly fastened.
- Connect the control unit connector, ensuring that the security lock is in the locked position.



Stepper motor

The control unit regulates the idle speed by controlling the throttle body motors directly. As a result, idle speed adjustment and maintenance of the components involved in idle speed regulation (stepper motors, thermoactuators, etc.) are not necessary.

Variable geometry intake

(IF AVAILABLE)

To access the variable geometry intake system, remove the air filter box cover.

The system consists of: two intake ducts for each manifold, which may be joined (long ducts) or separated (short ducts)

CAUTION

TAKE PARTICULAR CARE DURING REASSEMBLY: THE SCREW SEAT WITH THE CHAMFER IS ASSEMBLED IN THE FRONT PART



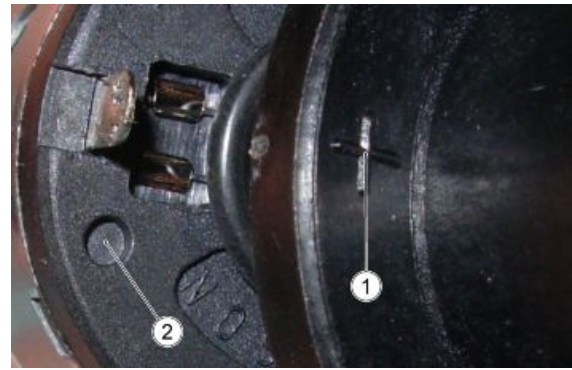
Electric motor

This is a DC motor actuating the upper portion of the intake ducts through an endless circuit.

CAUTION

TAKE PARTICULAR CARE DURING REASSEMBLY. THE POSITIVE SIDE (1) OF THE CONNECTOR MUST MATCH WITH THE SIDE WHERE A NOTCH (2) IS INDICATED.





a variable geometry control unit for managing the system, interfaced with the engine injection control unit



Operation

At key-ON, the variable geometry control unit lowers the ducts (if still in the raised position).

Subsequently, depending on the control voltage on PIN 2 from the injection ECU (0V down, 5V up), the ECU drives the electric motor with the relative polarity for raising or lowering the ducts.

The drive voltage delivered to the motor is determined in relation to battery voltage and the motor is stopped once a given current limit is reached or if the time-out period of 500 ms has elapsed.

There is no feedback relative to duct position! If in doubt, use the diagnostic instrument to actuate the ducts.

In the case of a defect in the variable geometry control unit, an error message is sent immediately to the engine injection ECU.

The variable geometry control unit does store errors



See also

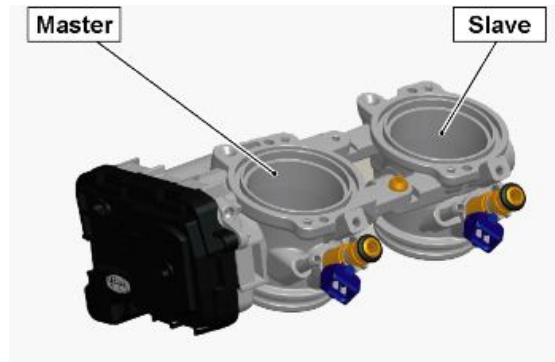
Variable geometry intake

Variable geometry intake

Cylinders synchronisation

The control unit receives information on the intake pressure in the four ducts from the two pressure sensors: as the control unit knows the timing phase of the cylinders, it can calculate the individual pressure of the four cylinders.

The control unit can equalise the depression between the front and rear cylinder banks by controlling two motors that are independent of the throttle bodies, but cannot equalise the pressure between the master cylinder (the cylinder closest to the motor) and the slave cylinder.



If irregular idling is noted, the By-pass screws can be checked and adjusted if necessary to ensure correct equalisation between cylinders 1-3 and 2-4.

On the diagnostic instrument, select Cylinder pressure equalisation from the Adjustable parameters screen.

In order for the procedure to start:

- the engine must have a water temperature above 80 °C (176 °F);
- be at the idling speed;
- there may not be any control unit errors.

As soon as the fans are activated (approx. 101°C - 214°F), the procedure is aborted and cannot be carried out.

During the procedure, the position of the handgrip position sensor is not considered.

A screen is displayed indicating the By-pass screws for cylinders 1 and 3 and whether the screw setting is correct, or whether it must be opened/closed by a small (1/8 turn) or large (1/4 turn) amount.

If the operation concerns slave screws, no removal of components is necessary.

If the operation concerns master screws, the air filter box must be removed.



After making any adjustment, wait for confirmation that the position of the adjusted screw position is now correct.



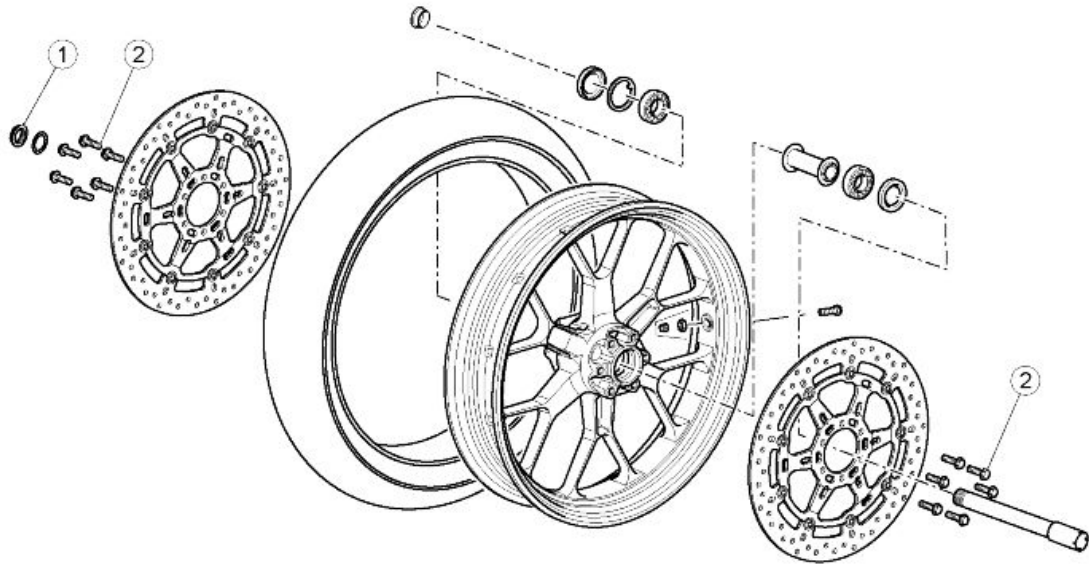
The procedure then continues with screws 2 and 4.

To ensure correct engine operation, one of the two screws of each throttle body must **always** be closed. Motorcycles are factory set with screws 1 and 2 turned by half a turn and screws 3 and 4 closed.

INDEX OF TOPICS

SUSPENSIONS

SUSP

Front
**FRONT WHEEL**

pos.	Description	Type	Quantity	Torque	Notes
1	Front wheel spindle nut	M25x1.5	1	80 Nm (59 lb ft)	-
2	Front brake disc fixing screws	M8	6 + 6	30 Nm (22.13 lb ft)	Loct. 243

Removing the front wheel

- Hold the vehicle front part.
- Remove the front mudguard.
- Unscrew the screws fixing the front pliers and slide them off the disc.



- Remove the wheel axle fixing nut.
- Retrieve the sealing washer.



- Loosen the screws on the wheel axle clamps.



- Tap the wheel axle slightly with a rubber mallet so that the hole on the opposite side is exposed.
- Remove the wheel axle by inserting a screwdriver in the holes on the pin.



- During extraction, support the wheel and then remove it.



Checking the front wheel

FRONT WHEEL BEARINGS

Carry out the check with the bearings fitted on the wheel.



CHECK THAT ALL PARTS ARE IN GOOD CONDITION, ESPECIALLY THOSE LISTED AS FOLLOWS.

ROTATION CHECK

- Manually rotate the inside ring of each bearing. Rotation must be constant, smooth and noiseless.

If one or both bearings do not fall within the control parameters:

- Replace both wheel bearings.

RADIAL AND AXIAL CLEARANCE CHECK

- Check the radial and axial clearance.

Axial clearance: a minimum axial clearance is allowed.

Radial clearance: none.

If one or both bearings do not fall within the control parameters:

- Replace both wheel bearings.



ALWAYS REPLACE BOTH BEARINGS.

ALWAYS REPLACE THE BEARINGS WITH OTHERS OF THE SAME TYPE.

GASKETS

- Check that the gaskets are in good conditions; replace them if they show signs of damage or excessive wear.

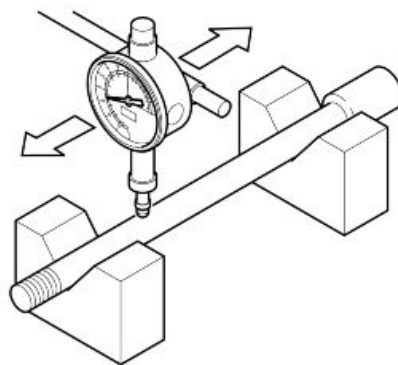


ALWAYS REPLACE BOTH GASKETS.

ALWAYS REPLACE THE GASKETS WITH OTHERS OF THE SAME TYPE.

WHEEL AXLE

- Use a dial gauge to check the wheel axle eccentricity. Replace the wheel axle if the eccentricity exceeds the limit value.

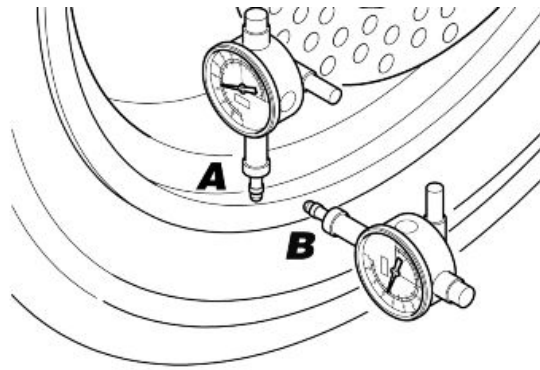


Characteristic

Maximum eccentricity:

0.25 mm (0.0098 in)

- Using a dial gauge, check that the radial (A) and the axial (B) eccentricities of the rim do not exceed the limit value. An excessive eccentricity is usually caused by worn or damaged bearings. Replace the rim if, after replacing the bearings, the value is not within the specified limit.

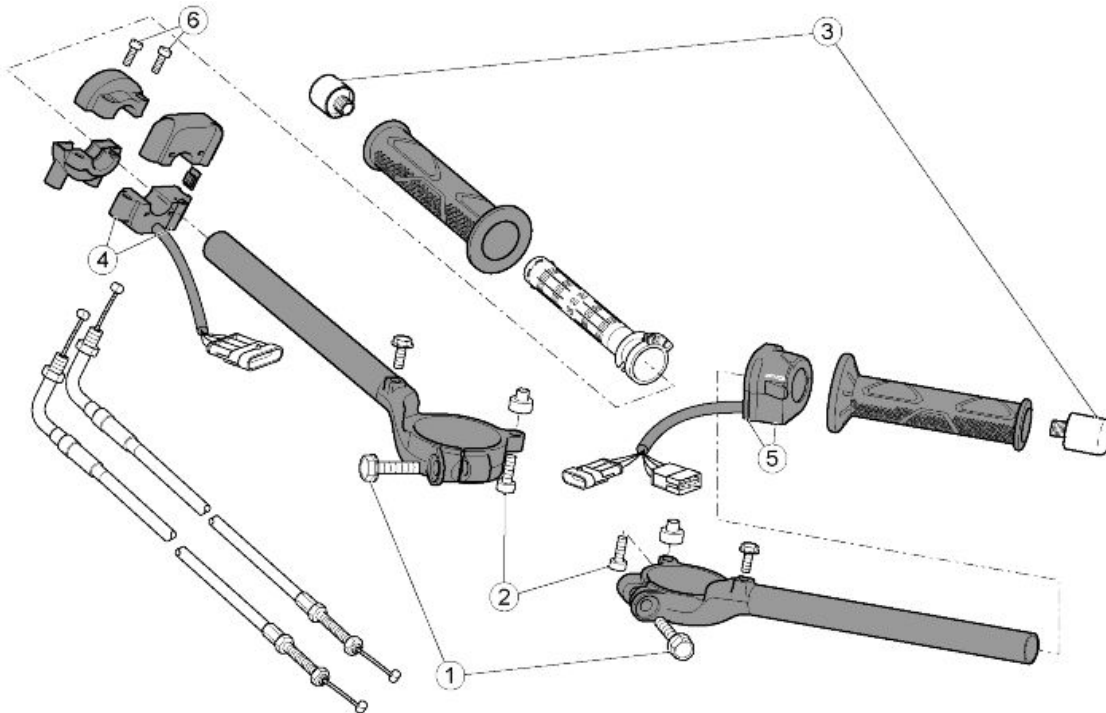


Characteristic

Maximum radial and axial eccentricity:

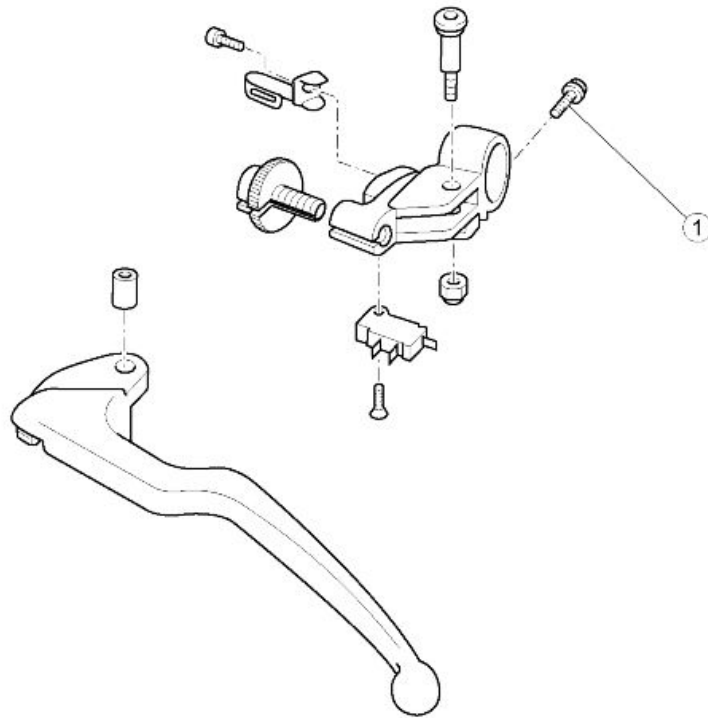
0.8 mm (0.031 in)

Handlebar



HANDLEBAR AND CONTROLS

pos.	Description	Type	Quantity	Torque	Notes
1	Screw fastening the semi-handlebar collar to the fork sleeves	M8	1 + 1	25 Nm (18.44 lbf ft)	-
2	Semi-handlebar safety screw	M6	1+1	10 Nm (7.37 lbf ft)	-
3	Anti-vibration counterweight fastener	M18x1.5	1+1	20 Nm (14.75 lbf ft)	-
4	Right light switch	M4	2	1.5 Nm (1.11 lbf ft)	-
5	Left light switch	M5	2	1.5 Nm (1.11 lbf ft)	-
6	Throttle control fixing screws	M5	2	2 Nm (1.47 lbf ft)	-

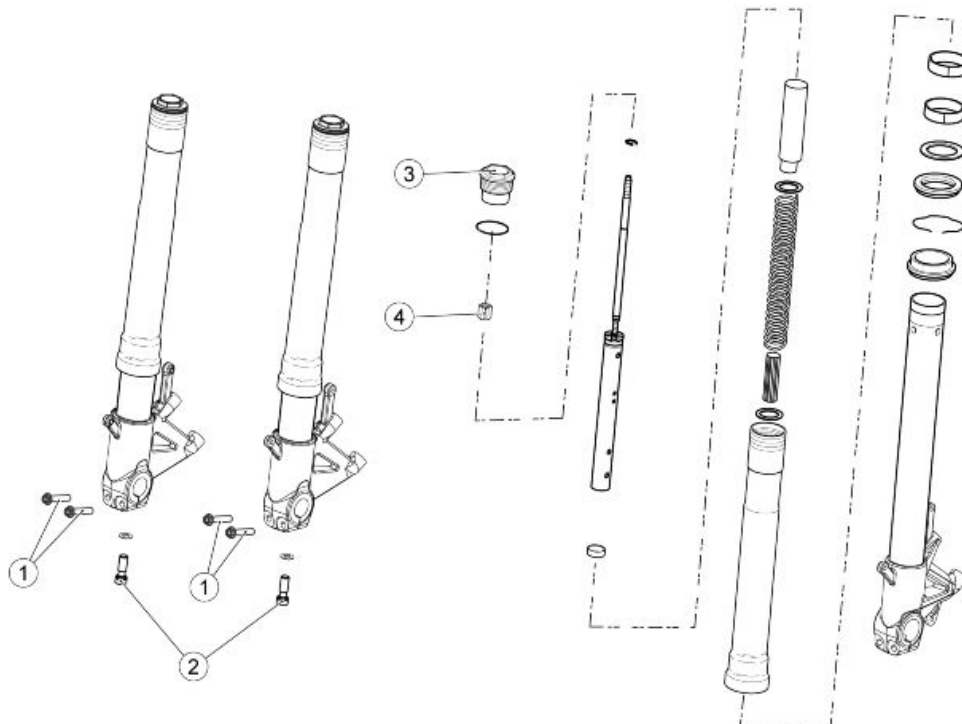


CLUTCH LEVER

pos.	Description	Type	Quantity	Torque	Notes
1	Clutch lever collar fixing screws	M6	1	10 Nm (7.37 lbf ft)	-

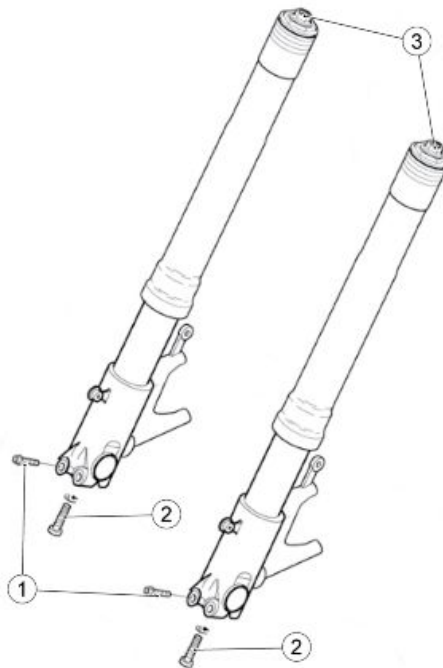
Front fork

Diagram



FRONT FORK - SACHS

pos.	Description	Type	Quantity	Torque	Notes
1	TEFL screw (fasten onto Fork Hubs)	M6x40	4	10 Nm (7.37 lb ft)	-
2	Screw (Piston fixing to the stem base)	-	2	30 Nm (22.13 lb ft)	-
3	Upper cover	-	2	20 Nm (14.75 lb ft)	-
4	Upper cover locking nut	-	2	20 Nm (14.75 lb ft)	-
-	Speed sensor bracket screw	M5x12	1	0.6 Nm (0.44 lb ft)	-



FRONT FORK - SHOWA

pos.	Description	Type	Quantity	Torque	Notes
1	Calliper mounting bracket fixing screws	M8	2+2	22 Nm (16.23 lbf ft)	-
2	Pumping member fixing screw	-	1+1	30 - 39 Nm (22.13 - 28.76 lbf ft)	-
3	Sleeve top cap	-	1+1	30 - 39 Nm (22.13 - 28.76 lbf ft)	-
-	Speed sensor bracket screws	-	1	-	-

Adjustment

NOTE

THE FOLLOWING OPERATIONS REFER TO THE SACHS FORKS.

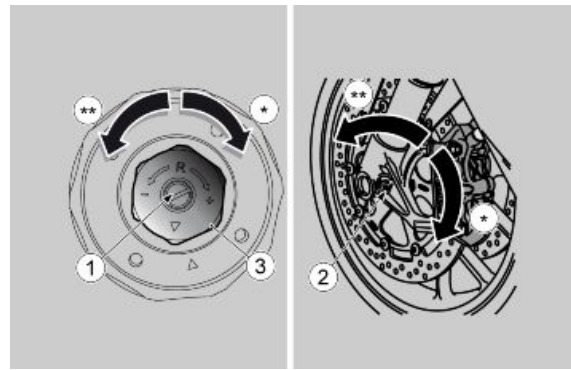
Standard front fork setting is adjusted to suit most high and low speed riding conditions, whether the vehicle is partially or fully loaded.

However, the setting can be modified for specific needs according to vehicle use.

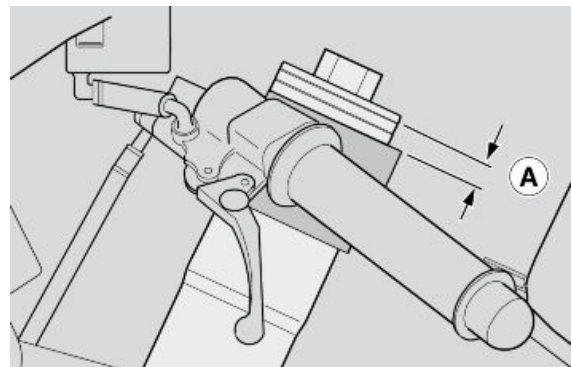


RACING TRACK SETTINGS MUST BE DONE ONLY FOR OFFICIAL COMPETITIONS OR SPORTS EVENTS WHICH ARE, IN ALL CASES, AWAY FROM NORMAL ROAD TRAFFIC AND WITH THE AUTHORISATION OF THE RELEVANT AUTHORITIES.

IT IS STRICTLY FORBIDDEN TO RIDE A VEHICLE SET FOR RACING ON ROADS AND MOTORWAYS.



WHEN COUNTING THE NUMBER OF CLICKS AND/OR TURNS OF ADJUSTMENT SCREWS (1 - 2), ALWAYS START FROM THE STIFFEST SETTING (ADJUSTER SCREW TURNED FULLY CLOCKWISE). WHEN COUNTING THE NUMBER OF CLICKS AND/OR TURNS OF ADJUSTMENT SCREW (3), ALWAYS START FROM THE SOFTEST SETTING (ADJUSTER SCREW TURNED FULLY ANTI-CLOCKWISE).



FRONT FORK - RSV4 R - STANDARD SETTING (SACHS - FOR ROAD USE ONLY)

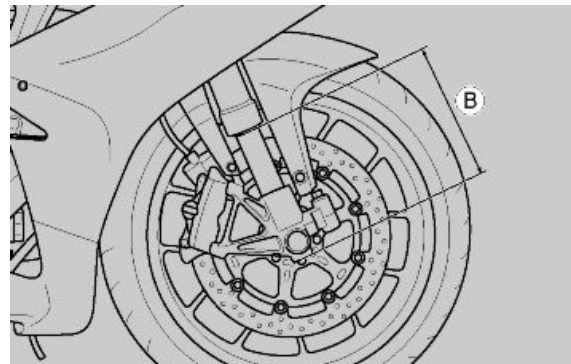
Specification	Desc./Quantity
Rebound damping adjustment, screw (1)	Unscrew (**) 10 clicks from fully closed (*)
Compression damping adjustment, screw (2)	Unscrew (**) 6 clicks from fully closed (*)
Spring preloading, nut (3)	screw (*) 5 turns from fully open (**)
Stems (A) (***) protrusion from top plate (excluding cover)	1 notches/ 4 mm (1 notches/0.16 in)
Theoretical fork failure (motorcycle + rider 70kg - 154lb) (B)	33-35 +/- 1 mm (1.30-1.38 +/- 0.039 in)

FRONT FORK - RSV4 R - RACING ADJUSTMENT RANGE (SACHS - TRACK USE ONLY)

Specification	Desc./Quantity
Rebound damping adjustment, screw (1)	Unscrew (**) 7-8 clicks (*) from fully closed
Compression damping adjustment, screw (2)	Unscrew (**) 5-4 clicks (*) from fully closed
Spring preloading, nut (3)	screw (*) 5 turns from fully open (**)
Stems (A) (***) protrusion from top plate (excluding cover)	1 notches/ 4 mm (1 notches/0.16 in)
Theoretical fork failure (motorcycle + rider 70kg - 154lb) (B)	33-35 +/- 1 mm (1.30-1.38 +/- 0.039 in)

(*) = clockwise

(**) = anticlockwise



NOTE

TO CHECK FOR FRONT FORK FAILURE, MEASURE THE DIFFERENCE BETWEEN THE BEGINNING OF THE WHEEL HUB AND THE END OF THE FORK SLEEVE

NOTE

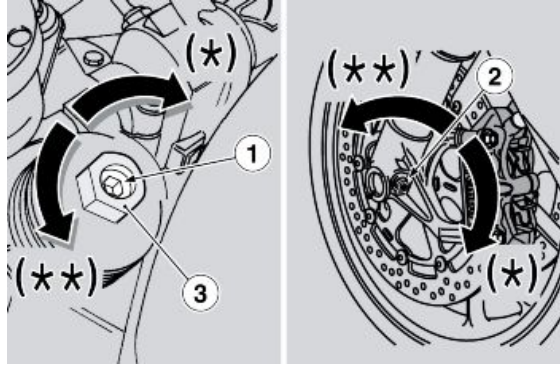
THE FOLLOWING OPERATIONS REFER TO THE SHOWA FORKS.

Standard front fork setting is adjusted to suit most high and low speed riding conditions, whether the vehicle is partially or fully loaded.

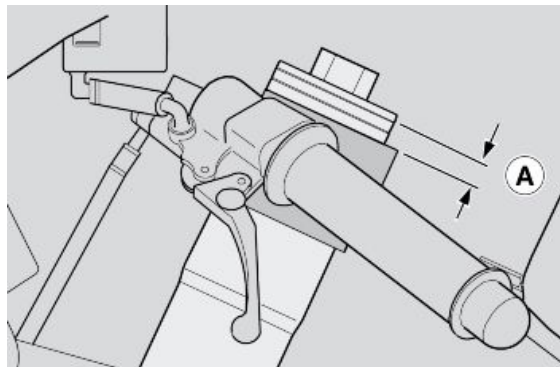
However, the setting can be modified for specific needs according to vehicle use.



**RACING TRACK SETTINGS MUST BE DONE ONLY FOR OFFICIAL COMPETITIONS OR SPORTS EVENTS WHICH ARE, IN ALL CASES, AWAY FROM NORMAL ROAD TRAFFIC AND WITH THE AUTHORISATION OF THE RELEVANT AUTHORITIES.
IT IS STRICTLY FORBIDDEN TO RIDE A VEHICLE SET FOR RACING ON ROADS AND MOTORWAYS.**



WHEN COUNTING THE NUMBER OF CLICKS AND/OR TURNS OF ADJUSTMENT SCREWS (1 - 2), ALWAYS START FROM THE STIFFEST SETTING (ADJUSTER SCREW TURNED FULLY CLOCKWISE). WHEN COUNTING THE NUMBER OF CLICKS AND/OR TURNS OF ADJUSTMENT SCREW (3), ALWAYS START FROM THE SOFTEST SETTING (ADJUSTER SCREW TURNED FULLY ANTI-CLOCKWISE).



FRONT FORK - STANDARD SETTING (FOR ROAD USE ONLY)

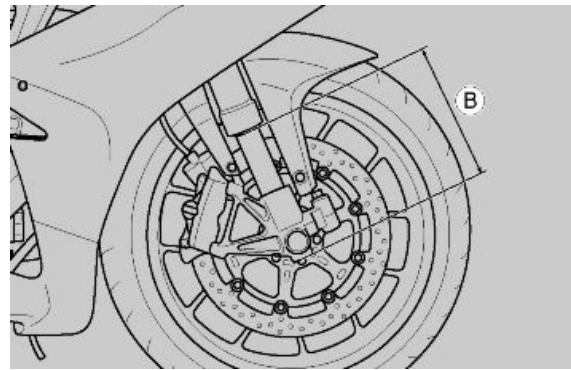
Specification	Desc./Quantity
Rebound damping adjustment, screw (1)	Unscrew (**) 1.5 turns from fully closed (*)
Compression damping adjustment, screw (2)	Unscrew (**) 1 turn from fully closed (*)
Spring preloading, nut (3)	Unscrew (**) 5 notches from fully closed (*)
Stems (A) (***) protrusion from top plate (excluding cover)	3 notches/ 12 mm (3 notches/0.47 in)
Theoretical fork failure (motorcycle + rider 70kg - 154lb) (B)	33-35 +/- 1 mm (1.30-1.38 +/- 0.039 in)

FRONT FORK - RACING ADJUSTMENT RANGE (TRACK USE ONLY)

Specification	Desc./Quantity
Rebound damping adjustment, screw (1)	Unscrew (**) 3/4 - 1 turn (*) from fully closed
Compression damping adjustment, screw (2)	Unscrew (**) 0.5 turn from fully closed (*)
Spring preloading, nut (3)	Unscrew (**) 4 - 5 notches from fully closed (*)
Stems (A) (***) protrusion from top plate (excluding cover)	3 notches/ 12 mm (3 notches/0.47 in)
Theoretical fork failure (motorcycle + rider 70kg - 154lb) (B)	35 +/- 1 mm (1.38 +/- 0.039 in)

(*) = clockwise

(**) = anticlockwise



NOTE

TO CHECK FOR FRONT FORK FAILURE, MEASURE THE DIFFERENCE BETWEEN THE BEGINNING OF THE WHEEL HUB AND THE END OF THE FORK SLEEVE

Removing the fork legs

- Remove the front wheel.
- Support the fork stanchion and loosen the screws on the upper yoke.



- Loosen the screws on the semi-handlebars.



- Loosen the lower yoke screws.
- Remove the stanchion.



See also

Removing the front wheel

Draining oil

NOTE

THE FOLLOWING OPERATIONS REFER TO THE SACHS FORKS.

NOTE

THE OPERATIONS DESCRIBED BELOW ARE VALID FOR BOTH STEMS.

- Using the appropriate tool fasten the fork in the vice.



Specific tooling

AP8140149 Protection for fitting operations

- Operating on the upper screw, unload the spring.



- Loosen the cover without unscrewing it completely.



- Place the fork vertically locking it in a vice by the specific tool.
- Completely unscrew the plug.

Specific tooling**AP8140149 Protection for fitting operations**

- Using the specific tool, fixed to the pre-loading pipe, compress the spring.
- Insert a spanner in the lock nut of the cover.

Specific tooling**020888Y Pliers for pre-fill pipe**

- Unscrew the cap and remove it.



- Remove the spring preload pipe.



- Remove the lock nut and the washer.



- Remove the spring paying attention to drain the oil correctly.



- Drain the oil into a container of suitable capacity to collect fluids.



DO NOT DISPOSE OF OIL INTO THE ENVIRONMENT. DISPOSE OF ENGINE OIL STORED IN A SEALED CONTAINER AND TAKE IT TO YOUR SUPPLIER OR TO THE NEAREST USED OIL RECLAMATION FIRM.



NOTE

THE FOLLOWING OPERATIONS REFER TO THE SHOWA FORKS.

- Lock the clamp sleeve using the specified tool.
- Reduce spring load to the minimum.

Specific tooling

8140149 Cover removal operations



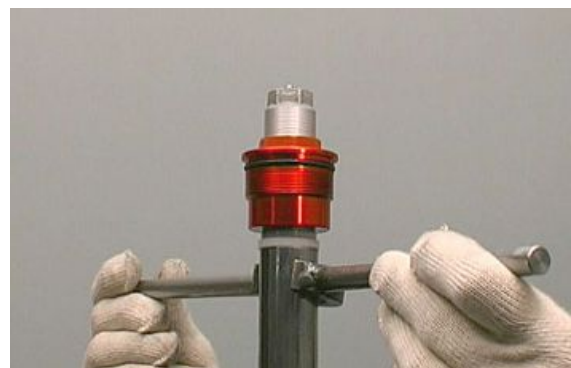
- Unscrew the sleeve top cap.



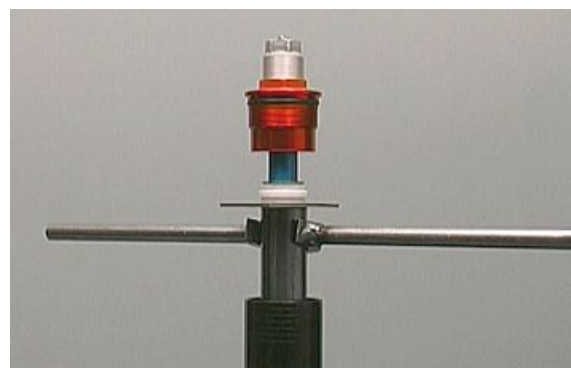
- Lock the fork end on a vice paying attention not to damage it.



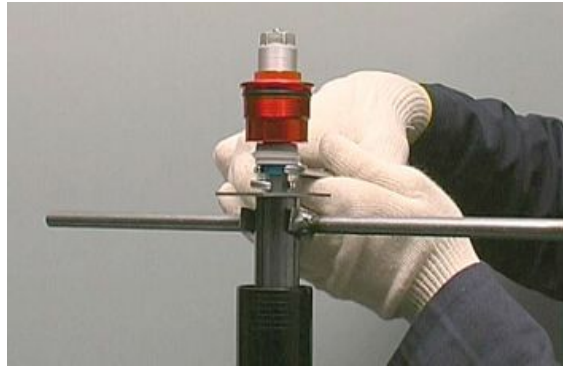
- Fit the specified tool on the spring coupling.



- Push down the tool to compress the spring and then fit the tool spacer below the cartridge lock nut.



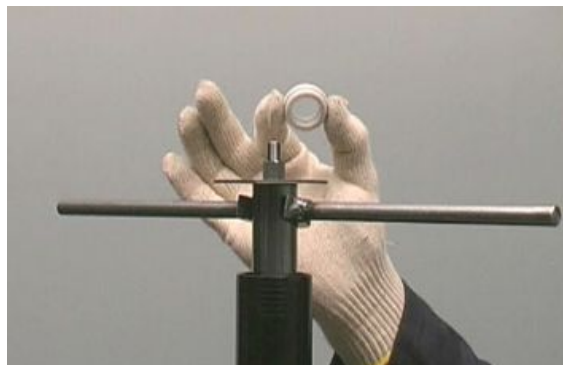
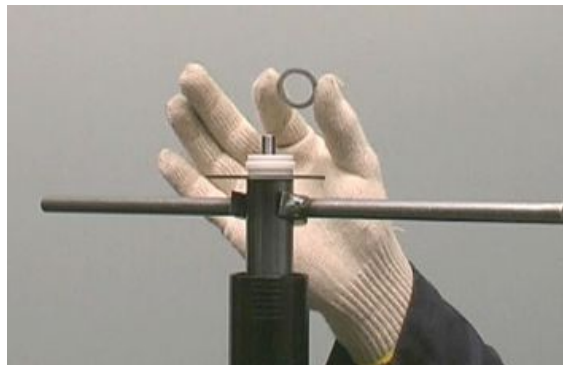
- Loosen the cap by the key grip and by making the lock nut turn.



- Remove the complete cap.



- Remove the spacer and the washer.
- Push down and compress the spring, slide off the spacer.



- Remove the spring coupling.



- Drain off oil into a collecting container and remove the spring.



Disassembling the fork

NOTE

THE FOLLOWING OPERATIONS REFER TO THE SACHS FORKS.

- Discharge the fork, remove the internal dipstick of the pumping member pin (1) and the washer (2).
- Operate repeatedly on the pumping member pin (3) so as to drain completely the oil from inside.



- Slide off the dust scraper from the sleeve using a screwdriver as a lever.
- During this operation, pay attention not to damage the sleeve rim.

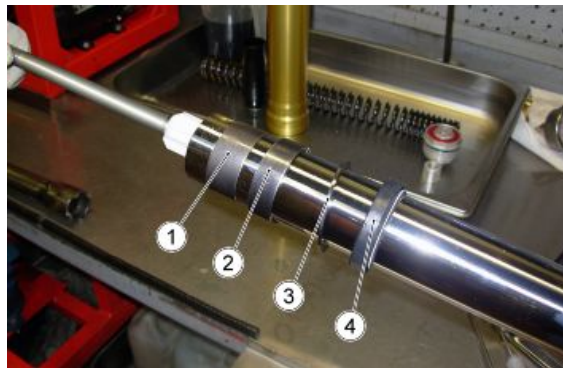


- Remove the retainer ring.

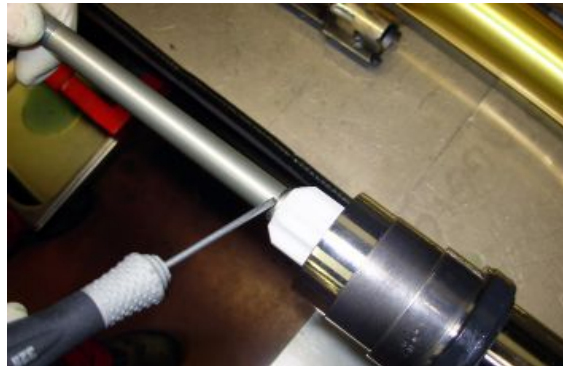


- Take out the sleeve from the stem using the stem as a hammer puller.

- Remove the fixed bushing (1), the movable bushing (2), the ring (3) and the oil seal (4) from the stem.



- Remove the lock seeger ring of the spring guide.
- Remove the spring guide.



- Using a hook spanner lock the pumping member pin
- Remove the stem bottom screw.

Specific tooling

020889Y Piston ring nut locking spanner

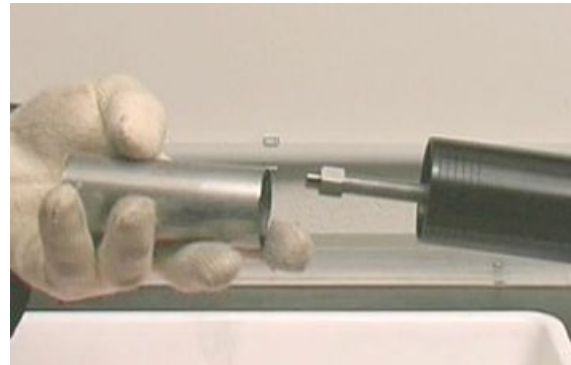


- Remove the pumping member pin.

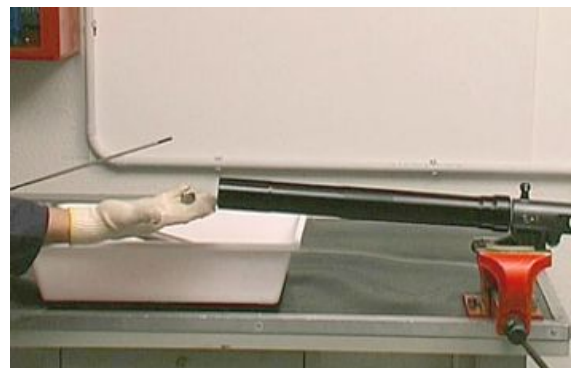
**NOTE**

THE FOLLOWING OPERATIONS REFER TO THE SHOWA FORKS.

- After emptying the oil, fasten the caliper mounting bracket of the fork stanchion in a vice.
- Position the washer and the lower spacer.



- Unscrew the cartridge fixing screw on the fork feet.
- Retrieve the centring bushing.



- Slide off the dust scraper from the sleeve using a screwdriver as a lever.
- During this operation, pay attention not to damage the sleeve rim.



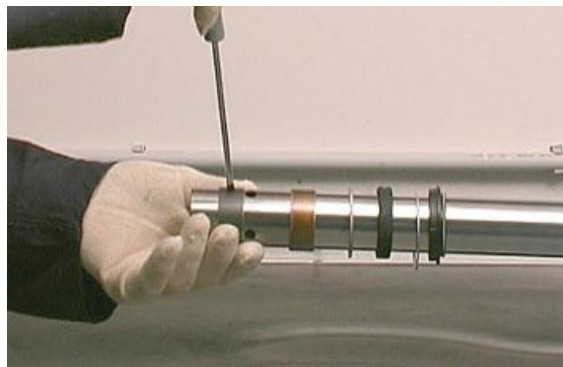
- Remove the retainer ring.

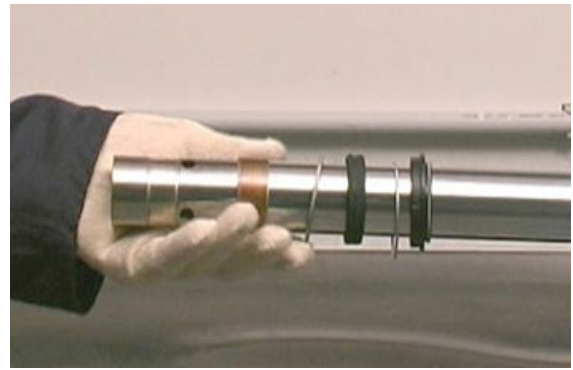


- Take out the sleeve from the stem using the stem as a hammer puller.



- From the stem remove the fixed fitted bushing, the movable bushing, the ring and the oil seal.





- Remove the ring and the dust guard.



See also

[Draining oil](#)

Checking the components

NOTE

THE FOLLOWING OPERATIONS REFER TO THE SACHS FORKS.

Stem

Check the sliding surface for scorings and/or scratches.

These scorings can be eliminated by rubbing them with wet sandpaper (grain 1).

If the scorings are deep, replace the stem.

Use a dial gauge to check that the stem bending is below the limit value.

If over the value, replace the stem.

CAUTION

A BENT STEM SHOULD NEVER BE STRAIGHTENED BECAUSE ITS STRUCTURE WOULD BE WEAKENED AND USING THE VEHICLE MAY BECOME DANGEROUS.

Characteristic**Bending limit:**

0.2 mm (0.00787 in)

Sleeve

Check that there are no damages and/or cracks; otherwise, replace it.

Spring

Check that the spring is in good conditions. Check that the spring length is within the limit value.

Replace the spring if its length does not fall within the limit values.

SPRING MINIMUM LENGTH WHEN UNLOADED: 265 mm (10.4 in)

Check that the following components are in good conditions:

- upper bushing;



- lower bushing;



- piston.

If there are signs of excessive wear or damage, replace the affected component.

CAUTION

REMOVE ANY IMPURITY IN THE BUSHINGS, TAKING CARE NOT TO SCRATCH THEIR SURFACE.



Replace the following components with new ones:

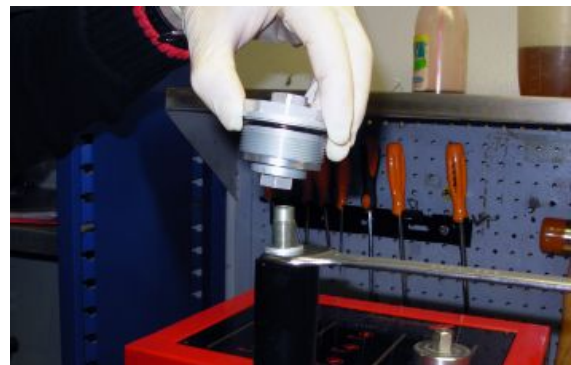
- seal ring;

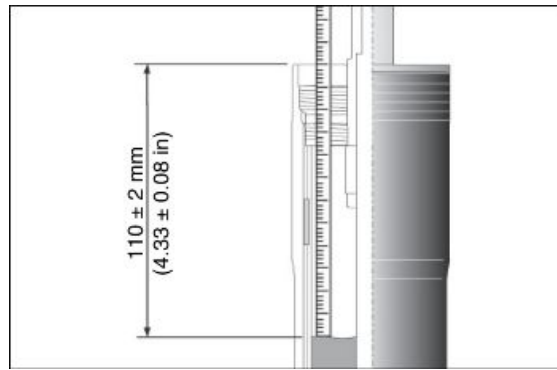


- dust gaiter;



- O-Ring on the cap.





Oil level: 110 +/- 2 mm (4.33 - 0.08 in) (from the sleeve edge, without a spring and with preload pipe).



THE SLEEVE MUST BE PERFECTLY UPRIGHT IN ORDER TO MEASURE THE CORRECT OIL LEVEL. THE OIL LEVEL MUST BE THE SAME IN BOTH STANCHIONS.

Characteristic

Fork oil

427 +/- 5 cm³ (26.06 +/- 0.30 cu.in) (for each stem)

NOTE

THE FOLLOWING OPERATIONS REFER TO THE SHOWA FORKS.

Stem

Check the sliding surface for scorings and/or scratches.

These scorings can be eliminated by rubbing them with wet sandpaper (grain 1).

If the scorings are deep, replace the stem.

Use a dial gauge to check that the stem bending is below the limit value.

If over the value, replace the stem.

CAUTION

A BENT STEM SHOULD NEVER BE STRAIGHTENED BECAUSE ITS STRUCTURE WOULD BE WEAKENED AND USING THE VEHICLE MAY BECOME DANGEROUS.

Characteristic

Bending limit:

0.2 mm (0.00787 in)

Sleeve

Check that there are no damages and/or cracks; otherwise, replace it.

Spring

Check that the spring is in good conditions. Check that the spring length is within the limit value.

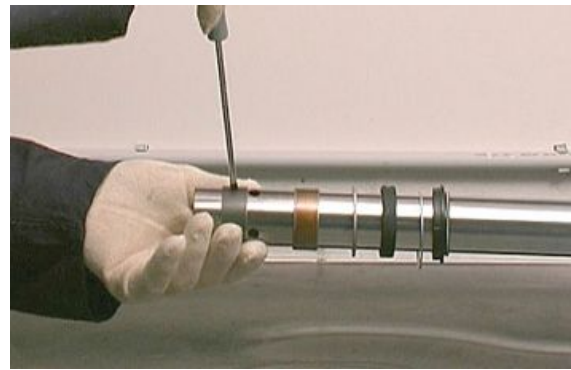
Replace the spring if its length does not fall within the limit values.

SPRING MINIMUM LENGTH WHEN UNLOADED: 284 mm (11.2 in)

Check that the following components are in good conditions:

- sliding bushing;
- guide bushing;

- piston.



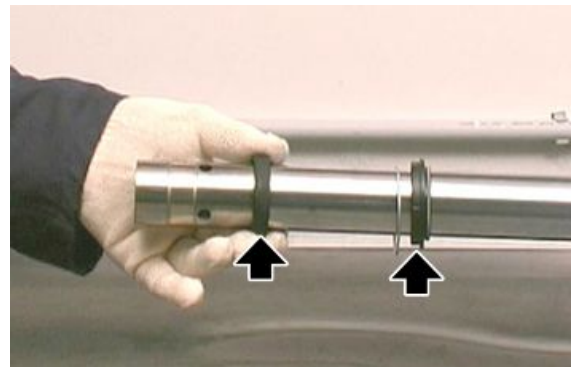
If there are signs of excessive wear or damage, replace the affected component.

CAUTION

REMOVE ANY IMPURITY IN THE BUSHINGS, TAKING CARE NOT TO SCRATCH THEIR SURFACE.

Replace the following components with new ones:

- gasket;
- dust guard gasket;
- the two O-rings on the regulator.



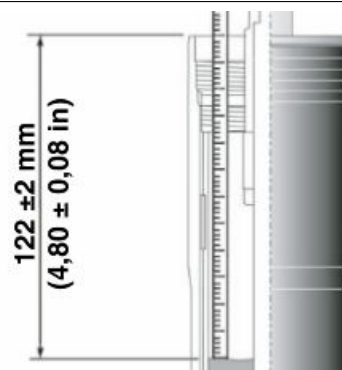
Oil level: 122 ± 2 mm (4.80 ± 0.08 in) (from the sleeve rim).



THE SLEEVE MUST BE PERFECTLY UPRIGHT IN ORDER TO MEASURE THE CORRECT OIL LEVEL. THE OIL LEVEL MUST BE THE SAME IN BOTH STANCHIONS.

Characteristic

Oil for R fork



520.0 +/- 2.5 cm³ (31.73 +/- 1.15 cu.in) (for each stem)

Reassembling the fork

NOTE

THE FOLLOWING OPERATIONS REFER TO THE SACHS FORKS.

NOTE

THE OPERATIONS DESCRIBED BELOW ARE VALID FOR BOTH STEMS.

- Lock the stem in a vice without damaging the surface.
- Protect the bearing tube end with adhesive tape.
- Lubricate the sliding edges with fork oil or sealing grease.
- Fit the dust gaiter, the retainer ring and the dust scraper on the stem.



- Fit the ring, the movable bushing and, after removing the tape, fit the fixed bushing.



- Fit the sleeve on the stem and set the oil seal into position with the aid of the specific tool.

Specific tooling

AP8140189 Oil seal fitting tool for Ø 43 mm (1.69 in) orifices

AP8140146 Weight



- Insert the retainer ring in its position.



- Fit the dust gaiter with the specific tool.

Specific tooling

AP8140189 Oil seal fitting tool for Ø 43 mm (1.69 in) orifices

AP8140146 Weight



- Insert the pumping member pin in the stem.



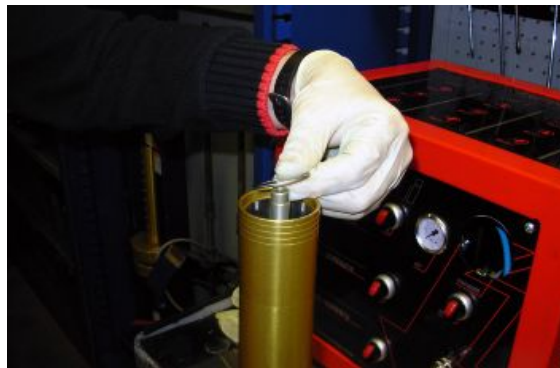
- Using a hook spanner lock the pumping member pin and tighten the fixing screw on the fork end to the prescribed torque.



Specific tooling

020889Y Piston ring nut locking spanner

- Insert the spring guide and lock it by the appropriate seeger.
- Place the fork vertically.
- Insert the washer.



- Refill the fork with oil according to the prescribed quantity.



- Fit the spring.

CAUTION

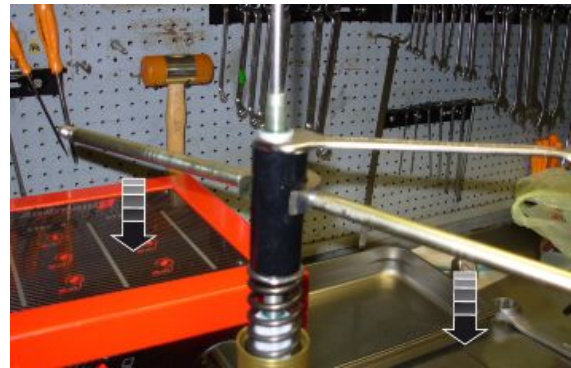
BE CAREFUL WHEN INSERTING THE SPRING SINCE THE COMPRESSED SPIRAL PART MUST BE PLACED DOWNWARDS.



See also

[Filling oil](#)

- Insert the washer that will be supported on the spring
- Insert and hand tighten the nut on the pumping member pin
- Place the preload pipe.
- Tighten the appropriate tool on the pumping member pin rod and keep it raised to allow, inserting a wrench in the nut by compressing the spring.



Specific tooling

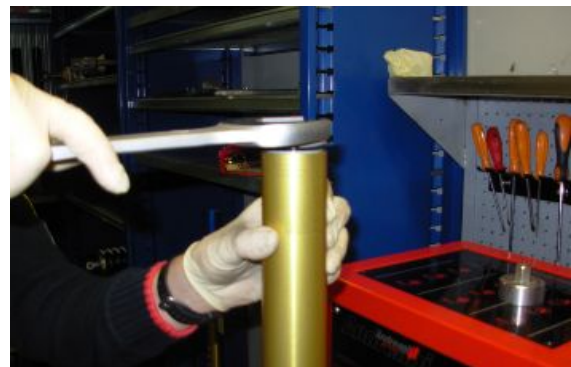
020890Y Piston stanchion support rod

AP8140147 Spacer tool

- Tighten the nut as much as possible.
- Insert the cover and tighten until it stops.



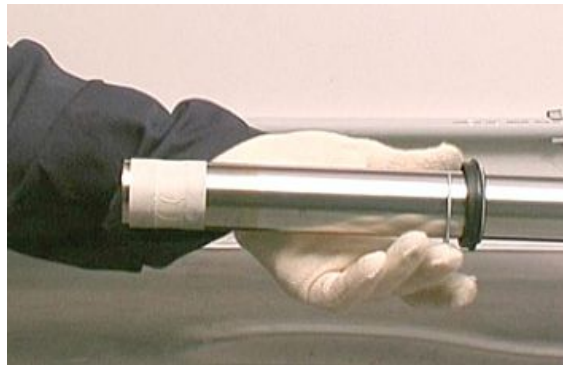
- Remove the specific tools.
- Screw the cover in the sleeve to the prescribed torque.



NOTE

THE FOLLOWING OPERATIONS REFER TO THE SHOWA FORKS.

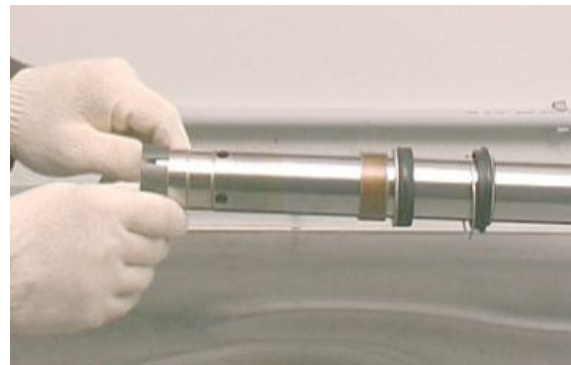
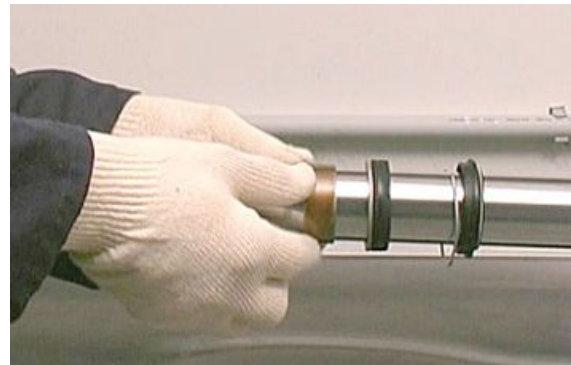
- Lock the stem in a vice without damaging the surface.
- Protect the bearing tube end with adhesive tape.
- Lubricate the sliding edges with fork oil or sealing grease.
- Fit on the slider the dust scraper, the retainer ring and the seal ring.



- The sealing ring must be placed with the stamped part facing the dust gaiter.



- Fit the ring, the movable bushing and, after removing the tape, fit the fixed bushing.



- Fit the sleeve on the stem and set the oil seal into position with the aid of the specific tool.

Specific tooling

8140145 Fitting tool for Ø 41 mm (1.61 in) sealing ring

8140146 Weight to be applied to the tool:
8140145



- Insert the retainer ring in its position.



- Fit the oil seal with the specific tool.

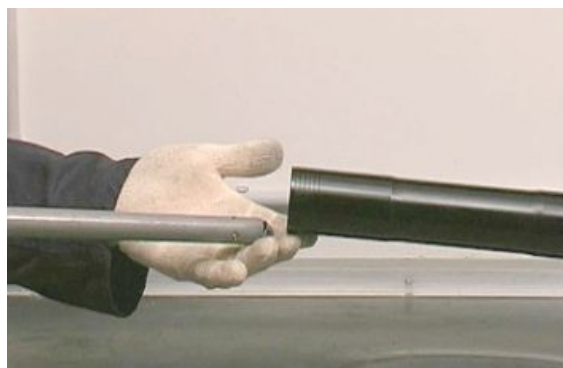
Specific tooling

8140145 Fitting tool for \varnothing 41 mm (1.61 in) sealing ring

**8140146 Weight to be applied to the tool:
8140145**



- Fit the centring bushing on the cartridge and insert the whole assembly in the fork.



- Tighten the screw fixing the pumping member on the fork end to the prescribed torque.



- Position the lower spacer and the washer.



- Fit the fork spring.
- Perform the fork oil filling.



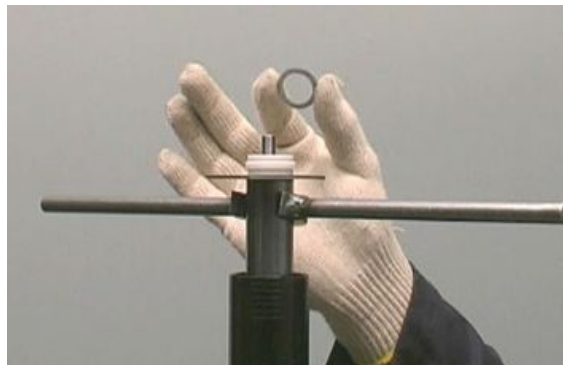
- Keep the sleeve in vertical position.
- Fill up the fork so that air bubbles trapped inside are freed.
- Fit the spring coupling.



- Fit the specified tool on the spring coupling so that the cartridge stem is locked in position.

Specific tooling**AP8140147 Spacer tool****8140148 Spacer / pumping member separating plate**

- Position the spacer and the washer.



- Screw the upper cover on the cartridge stem.





- Place the sleeve in the vice using the specified tool.
- Screw the upper cover, tightening it to the prescribed torque.

Specific tooling

AP8140149 Protection for fitting operations



Filling oil

NOTE

THE FOLLOWING OPERATIONS REFER TO THE SACHS FORKS.

- Place the sleeve upright in a vice fitted with protection shoes.
- Compress the sleeve in the stem. Place a support under the stem in order to leave it compressed.
- Pour part of the fork oil into the sleeve.
- Wait some minutes until the oil fills all the ducts.
- Pour the remaining oil.
- Pump out oil a few times.
- Measure the air gap between the oil level and the rim.



THE SLEEVE MUST BE PERFECTLY UPRIGHT IN ORDER TO MEASURE THE CORRECT OIL LEVEL. THE OIL LEVEL MUST BE THE SAME IN BOTH STANCHIONS.

Specific tooling

AP8140149 Protection for fitting operations

Oil level: 110 +/- 2 mm (4.33 - 0.08 in) (from the sleeve edge, without a spring and with preload pipe).

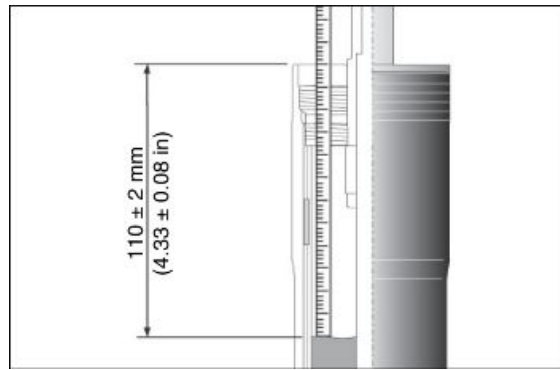


THE SLEEVE MUST BE PERFECTLY UPRIGHT IN ORDER TO MEASURE THE CORRECT OIL LEVEL. THE OIL LEVEL MUST BE THE SAME IN BOTH STANCHIONS.

Characteristic

Fork oil

427 +/- 5 cm³ (26.06 +/- 0.30 cu.in) (for each stem)



NOTE

THE FOLLOWING OPERATIONS REFER TO THE SHOWA FORKS.

- Place the sleeve upright in a vice fitted with protection shoes.
- Compress the sleeve in the stem. Place a support under the stem in order to leave it compressed.
- Pour part of the fork oil into the sleeve.
- Wait some minutes until the oil fills all the ducts.
- Pour the remaining oil.
- Pump out oil a few times.
- Measure the air gap between the oil level and the rim.



THE SLEEVE MUST BE PERFECTLY UPRIGHT IN ORDER TO MEASURE THE CORRECT OIL LEVEL. THE OIL LEVEL MUST BE THE SAME IN BOTH STANCHIONS.

Specific tooling

AP8140149 Protection for fitting operations

Oil level: 122 ± 2 mm (4.80 ± 0.08 in) (from the sleeve rim).

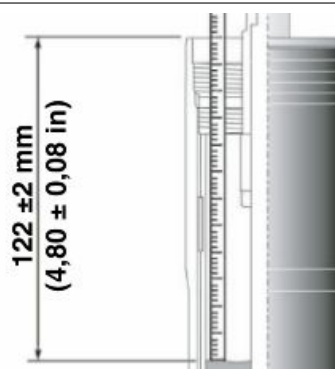


THE SLEEVE MUST BE PERFECTLY UPRIGHT IN ORDER TO MEASURE THE CORRECT OIL LEVEL. THE OIL LEVEL MUST BE THE SAME IN BOTH STANCHIONS.

Characteristic

Oil for R fork

520.0 +/- 2.5 cm³ (31.73 +/- 1.15 cu.in) (for each stem)



Steering damper

Adjusting

- It is not possible to make any adjustment on the steering damper.

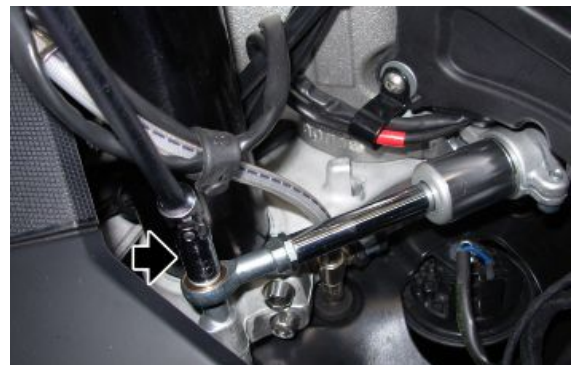


Removing

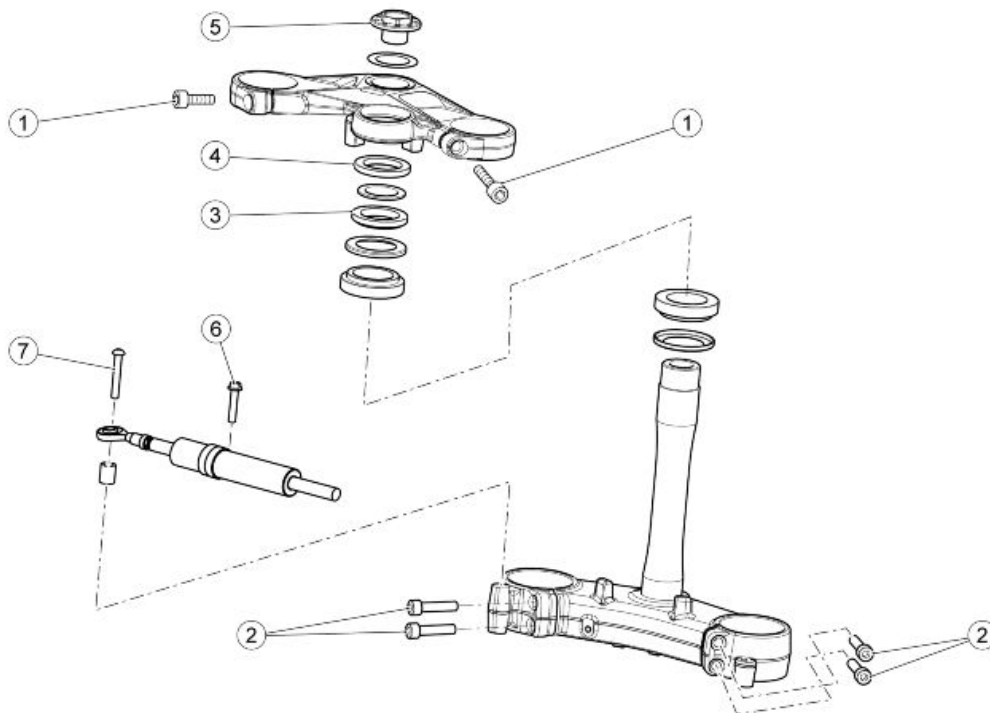
The steering damper steering more precise and stable, improving motorcycle handling in all conditions. The damper is fastened at the front of the motorcycle between the base of the headstock and the frame

Removal:

- Undo the frame fixing screw operating on the upper side through the hole.
- Unscrew the fixing screw at the base of the headstock.
- Remove the steering damper.



Steering bearing



STEERING

pos.	Description	Type	Quantity	Torque	Notes
1	Screws fastening upper yoke to stanchions	M8	2	25 Nm (18.44 lb ft)	-
2	Screws fastening lower yoke to stanchions	M8	4	25 Nm (18.44 lb ft)	-
3	Headstock lock ring	M35x1	1	35 ± 5 Nm (25.81 ± 3.69 lb ft)	Bend the tabs into the notches in the lock ring
4	Headstock counter-lock ring	M35x1	1	Manual +35°	Bend the tabs into the notches in the lock ring
5	Upper yoke fixing cap	-	1	100 Nm (73.76 lb ft)	-
6	Screw fastening shock absorber to frame	M6	1	10 Nm (7.37 lb ft)	-
7	Screw fastening shock absorber to lower yoke	M6	1	10 Nm (7.37 lb ft)	-

Adjusting play

- Place the vehicle so that the front wheel is off the ground.
- Carry out a handlebar rotation test, using a dynamometer at the hand grip external end.
- The handlebar resistance to rotation must be of 450 (+250 / -100 g) (0.88 +0.55 / -0.22 lb) in both directions.
- Adjust if clearance is detected.

NOTE

**THE STEERING COLUMN RESISTANCE TO ROTATION MUST BE PERFORMED IN THE TWO OPPOSITE ROTATION DIRECTIONS.
THE STEERING DAMPER MUST BE DISCONNECTED DURING MEASUREMENT.**

-
- Unscrew and remove the upper plate fixing cover on the headstock and collect the washer.



-
- Loosen the screws fixing the fork stations to the upper yoke.



-
- Working from both sides, unscrew and remove the semi-handlebar screws.



-
- Remove the upper yoke



- Rivet the safety washer on the head-stock.



- Undo the counter-lock ring, remove the safety washer then unscrew the lower lock ring in order to adjust the steering free play correctly.



- Adjust the preloading of the steering bearings by tightening the lower ring nut to the prescribed torque.
- Turn the steering 3-4 times completely from right to left and then check correct tightening torque of such ring nut.



-
- Place the safety washer, bending two opposite tongues inside the ring nut notches.



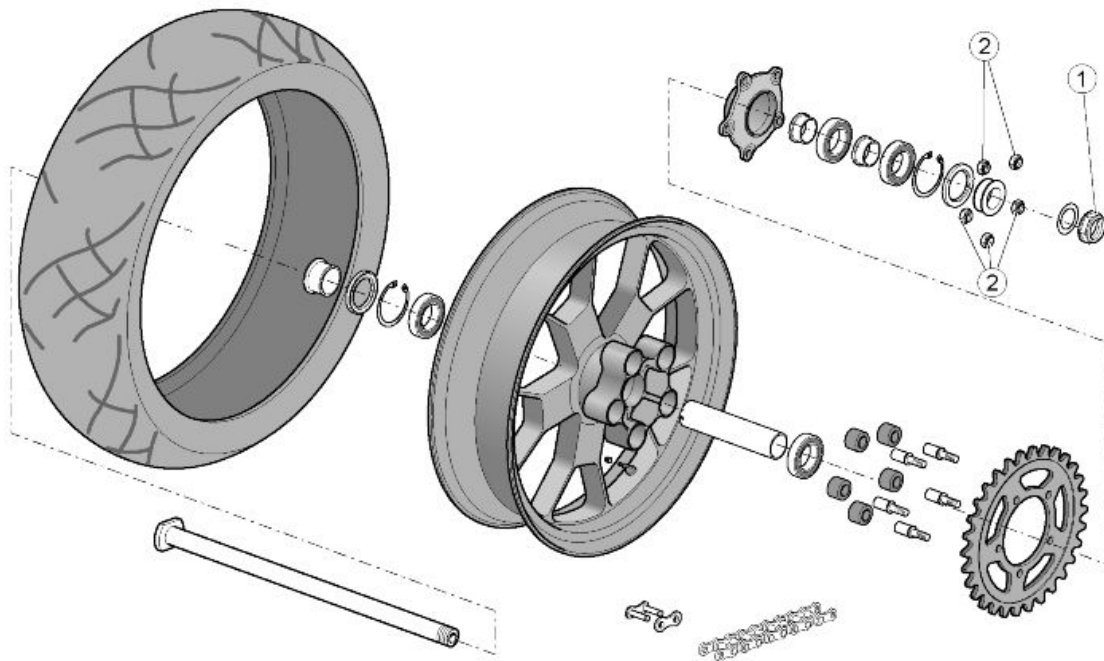
-
- Mount the upper ring nut and tighten it manually, another 35 degrees so that the grooves match the safety washer tongues.



- Rivet the tongues on the upper ring nut.
-
- Fit the upper fork plate by performing demounting operations in reverse order.



Rear



REAR WHEEL

pos.	Description	Type	Quantity	Torque	Notes
1	Rear wheel spindle nut	M25x1.5	1	120 Nm (88.5 lbf ft)	-
2	Screws fastening sprocket on sprocket mount	M10	5	50 Nm (36.88 lbf ft)	-

Removing the rear wheel

- Place the vehicle on its rear service stand.
- Loosen and remove the nut on the wheel axle.
- Retrieve the thrust washer and the left hand chain tensioner slider.



- Tap the wheel axle slightly to extract the head from its seat.
- Make the wheel move forward and release the gearing chain from the sprocket.



- Remove the wheel spindle together with the right hand chain tensioner skid.
- Remove the wheel by freeing the disc from the brake calliper.



- Holding the outer rim of the sprocket with both hands, slide off the final transmission unit by pulling it parallel to the wheel axis.



OPERATE WITH CAUTION. IF THE FINAL TRANSMISSION UNIT IS INSTALLED ON THE ANTI-VIBRATION BUFFER HOLDER, DO NOT TURN OVER OR ROTATE THE REAR WHEEL SPROCKET SIDE HORIZONTALLY, OR THE FINAL TRANSMISSION UNIT COULD SLIDE OUT AND FALL, AND THE SPROCKET MAY GET DAMAGED.

CAUTION

DO NOT UNSCREW THE FIVE NUTS. THE FINAL TRANSMISSION UNIT CAN BE SLID OFF COMPLETELY FROM THE ANTI-VIBRATION BUFFER HOLDER.

- Remove the final transmission unit.

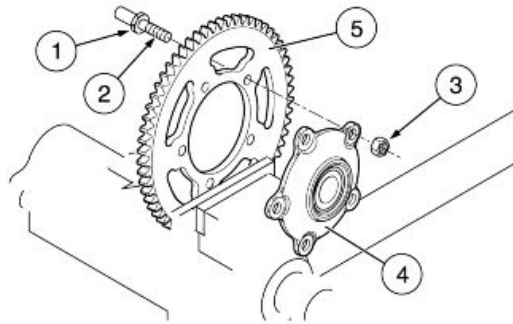
CAUTION

THE FLEXIBLE COUPLINGS REMAIN FITTED ON THEIR HOLDER.



- Remove all the flexible couplings.

- Using an Allen spanner on the related seat (1), lock the rotation of the threaded pin (2), unscrew and remove the self-locking nut (3) and the threaded pin (2).

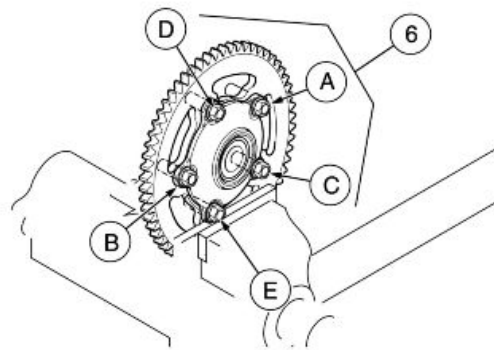


THE SELF-LOCKING NUTS (3) MUST BE REPLACED EVERY THREE SPROCKET REMOVALS. REPLACE THE SELF-LOCKING NUTS (3) WITH NUTS OF THE SAME TYPE.

- Remove the sprocket mounting (4).
- Clean the sprocket (5) and the sprocket mounting (4) with fresh detergent.

Reassembly:

- Fit the five threaded pins (2) on the sprocket (5).
- Install the sprocket mounting on the sprocket mounting - threaded pin assembly.
- Hand-tighten the five self-locking nuts (3).



NEVER INSTALL THE FINAL TRANSMISSION UNIT (6) ON THE WHEEL TO TIGHTEN THE SELF-LOCKING NUTS.



TO PROTECT THE SPROCKET, INSTALL (WOODEN OR ALUMINIUM) PROTECTIONS ON THE VICE JAWS. LOCK THE SPROCKET ONLY IN A VICE. DO NOT LOCK ANY OTHER COMPONENT OF THE FINAL TRANSMISSION UNIT.

- Lock sprocket in a vice.

CAUTION

TO AVOID POTENTIAL DISTORTIONS AND/OR INCORRECT COUPLING, TIGHTEN AS FOLLOWS:

- Using an Allen key on the specific seat (1), lock the rotation of the threaded pin (2), and applying half the specified torque, tighten the diametrically opposed elements in this sequence: (A) (B) (C) (D) (E).
- Repeat the previous operation, applying the specified tightening torque.

CAUTION

IN THIS WAY THE PRESSURE EXERTED BY THE FIXING ELEMENTS WILL BE EVENLY DISTRIBUTED ON THE COUPLING SURFACE.

Checking the rear wheel



CHECK THAT ALL PARTS ARE IN GOOD CONDITION, ESPECIALLY THOSE LISTED AS FOLLOWS.

REAR WHEEL BEARINGS

Carry out the check with the bearings fitted on the wheel.

ROTATION CHECK

- Manually rotate the inside ring of each bearing. Rotation must be constant, smooth and noiseless.

If one or both bearings do not fall within the control parameters:

- Replace both wheel bearings.



ALWAYS REPLACE BOTH BEARINGS.

ALWAYS REPLACE THE BEARINGS WITH OTHERS OF THE SAME TYPE.

- Check the radial and axial clearance.

Axial clearance: a minimum axial clearance is allowed.

Radial clearance: none.

If one or both bearings do not fall within the control parameters:

- Replace both wheel bearings.

REAR WHEEL GASKETS

- Check that the gaskets are in good conditions; replace them if they show signs of damage or excessive wear.

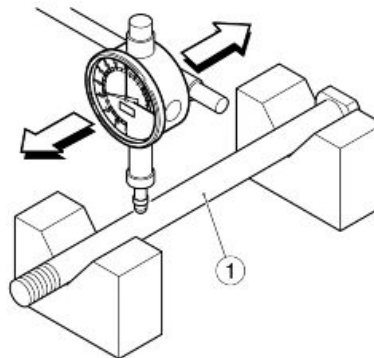


ALWAYS REPLACE BOTH GASKETS.

ALWAYS REPLACE THE GASKETS WITH OTHERS OF THE SAME TYPE.

REAR WHEEL AXLE

- Use a dial gauge to check the wheel axle eccentricity (1). Replace the wheel axle if the eccentricity exceeds the limit value (1).



Characteristic

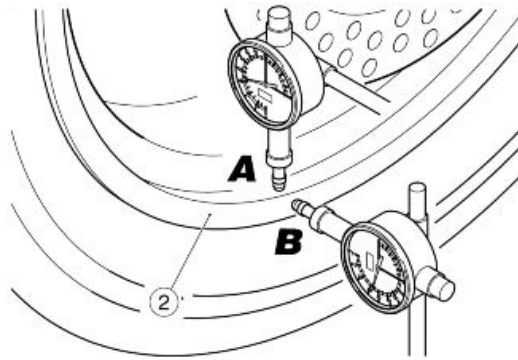
Maximum eccentricity:

0.25 mm (0.0098 in)

REAR WHEEL RIM

- Using a dial gauge, check that the radial (A) and the axial eccentricity (B) of the rim (2) do not exceed the limit value.

An excessive eccentricity is usually caused by worn or damaged bearings. Replace the rim (2) if after replacing the bearings, the value is not within the specified limit.



Characteristic

Maximum radial and axial eccentricity:

0.8 mm (0.031 in)

FINAL DRIVE UNIT BEARINGS

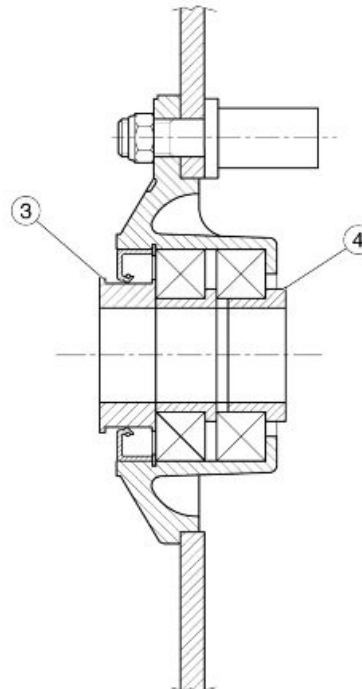
Carry out the check with the bearings fitted on the final drive unit.

ROTATION CHECK

- Remove the left spacer (3).
- Remove the right spacer (4).
- Manually rotate the inside ring of each bearing. Rotation must be constant, smooth and noiseless.

If one or both bearings do not fall within the control parameters:

- Replace both bearings of the final drive unit.



RADIAL AND AXIAL CLEARANCE CHECK

- Check the radial and axial clearance. Axial clearance: a minimum axial clearance is allowed. Radial clearance: none.

If one or both bearings do not fall within the control parameters:

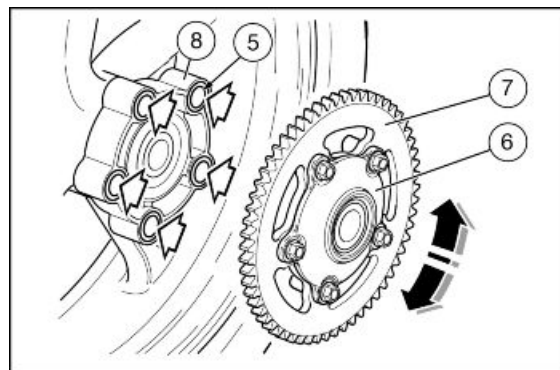
- Replace both bearings of the final drive unit.

FLEXIBLE COUPLING

Check that the flexible couplings (5) are not damaged or excessively worn.

To check:

- Fit the entire final drive unit (6) to the wheel.
- Manually rotate the sprocket (7) to right and left, and check the clearance between the flexible couplings (5) and their holder (8).



If there is excessive clearance:

- Replace all the flexible couplings (5).



ALWAYS REPLACE ALL THE FLEXIBLE COUPLINGS WITH OTHERS OF THE SAME TYPE.

SPROCKET

- Check the sprocket (7) tooting for proper conditions.

If there is excessive wear:

- Replace the sprocket.



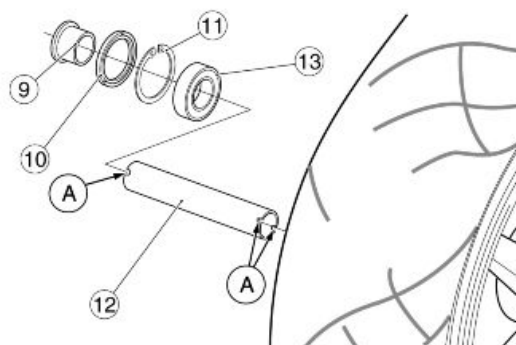
TO PREVENT EARLY WEAR OF NEW COMPONENTS, REPLACE THE SPROCKET, PINION AND TRANSMISSION CHAIN AT THE SAME TIME.

REAR WHEEL BEARINGS

- Remove the rear wheel.
- Clean the two sides of the hub with a cloth.

Working from the wheel right side:

- Remove the right spacer (9).
- Remove the sealing gasket (10).
- Remove the circlip (11).



CAUTION

THE CIRCLIP (11) IS FITTED ONLY ON THE WHEEL RIGHT SIDE.

The spacer end (12) is fitted with slots (A) for the extractor teeth to pass through.

- Take out the right bearing (13) with the specific extractor.

Specific tooling

AP8140180 Extractor for bushings

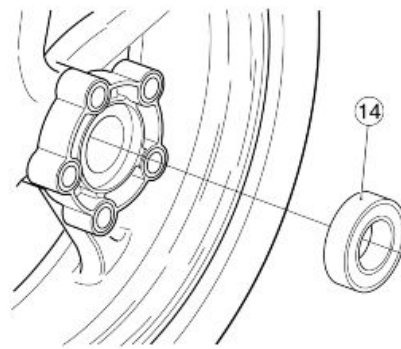
- Collect the inside spacer (12).

Working from the wheel left side:

- Take out the left bearing (16) with the specific extractor.

Specific tooling

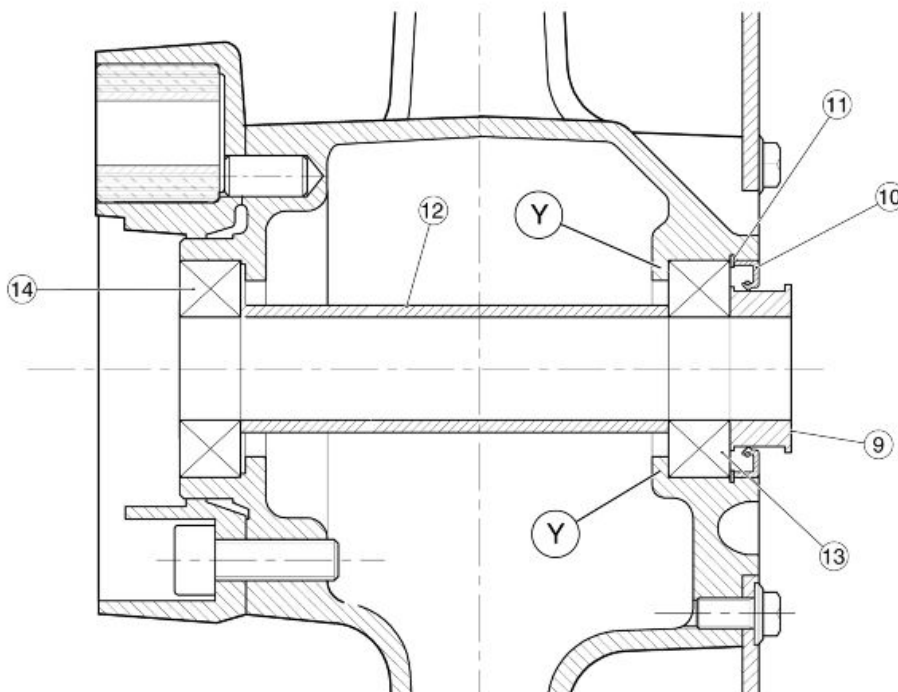
AP8140180 Extractor for bushings



- Clean the inside of the hub thoroughly.

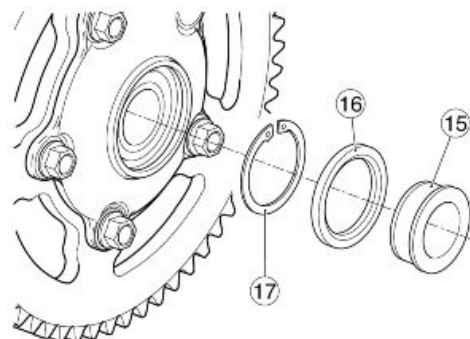
CAUTION

WASH ALL THE PARTS WITH CLEAN DETERGENT.



FINAL DRIVE UNIT - BEARING REMOVAL

- Remove the final drive unit.
- Clean the two sides of the hub with a cloth.
- Remove the left spacer (15).
- Remove the sealing gasket (16).
- Remove the circlip (17).



CAUTION

THE CIRCLIP (17) IS FITTED ONLY ON THE FINAL DRIVE UNIT, LEFT SIDE.

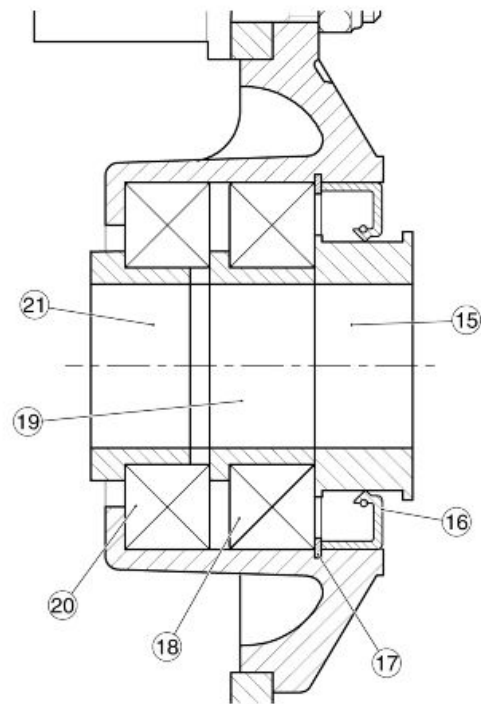
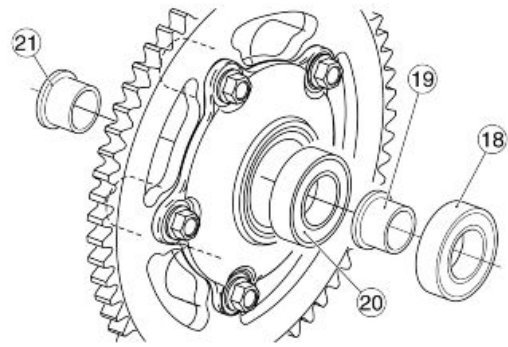
- Remove the left bearing (18) with the specific extractor.
- Collect the inside spacer (19).
- Remove the right bearing (20) with the specific extractor.
- Retrieve the right hand spacer (21).
- Clean the inside of the hub thoroughly.

CAUTION

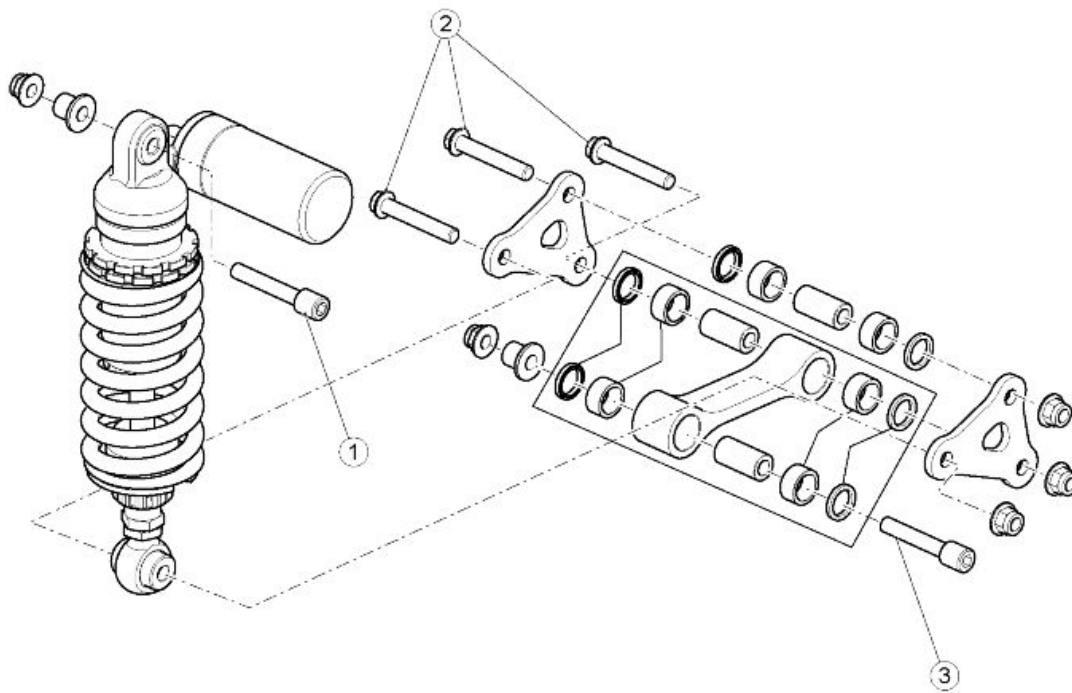
WASH ALL THE PARTS WITH CLEAN DETERGENT.

Specific tooling

AP8140180 Extractor for bushings



Shock absorbers



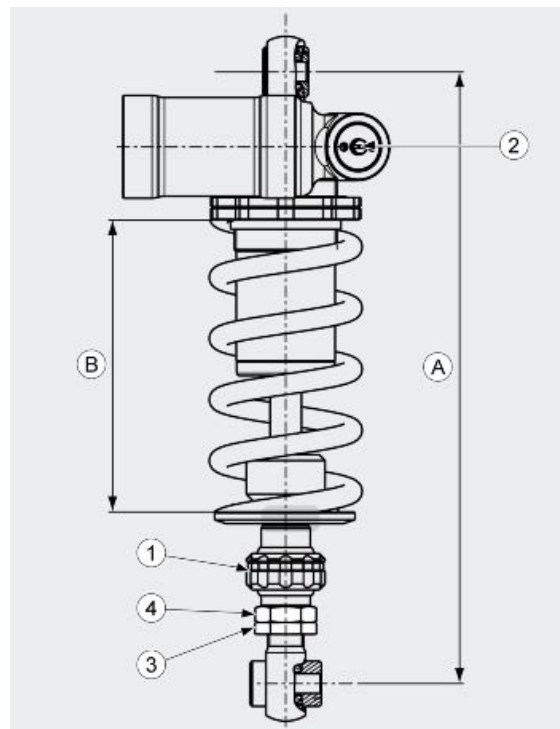
REAR SHOCK ABSORBER

pos.	Description	Type	Quantity	Torque	Notes
1	Upper shock absorber fixing screw	M10	1	50 Nm (36.88 lbf ft)	-
2	Dual connecting rod fixing screw	M10	3	50 Nm (36.88 lbf ft)	-
3	Screw fastening single connecting rod to chassis	M10	1	50 Nm (36.88 lbf ft)	-

Adjusting



SPORT SETTINGS MAY BE USED ONLY FOR OFFICIAL COMPETITIONS TO BE CARRIED OUT ON TRACKS, AWAY FROM NORMAL ROAD TRAFFIC AND WITH THE AUTHORISATION OF THE RELEVANT AUTHORITIES.



REAR SHOCK ABSORBER - STANDARD ADJUSTMENT (FOR USE ON ROAD)

Specification	Desc./Quantity
Shock absorber centre-to-centre distance (A)	310 ± 1.5 mm (12.20 ± 0.059 in)
(preloaded) Spring (B) length	148 ± 1.5 mm (5.83 ± 0.059 in)
Rebound adjustment, ring nut (1)	open (**) 20 ± 1 clicks from fully closed (*)
Compression adjustment, knob (2)	open (**) 1.5 click from fully closed (*)
Theoretical shock absorber failure (motorcycle + rider 70kg - 154lb) (C)	25 +/- 1 mm (0.98 +/- 0.039 in)

REAR SHOCK ABSORBER - RACING ADJUSTMENT RANGE (ONLY ON THE RACING TRACK)

Specification	Desc./Quantity
Shock absorber centre-to-centre distance (A)	313 +/- 1.5 mm (12.32 +/- 0.059 in)
(preloaded) Spring (B) length	144 - 145.5 mm (5.67 - 5.73 in) (2-3 turns)
Rebound adjustment, ring nut (1)	open (**) 13 +/- 2 clicks from fully closed (*)
Compression adjustment, knob (2)	open (**) 0.5 click from fully closed (*)
Theoretical shock absorber failure (motorcycle + rider 70kg - 154lb) (C)	20 +/- 1 mm (0.79 +/- 0.039 in)

(*) = clockwise

(**) = anticlockwise

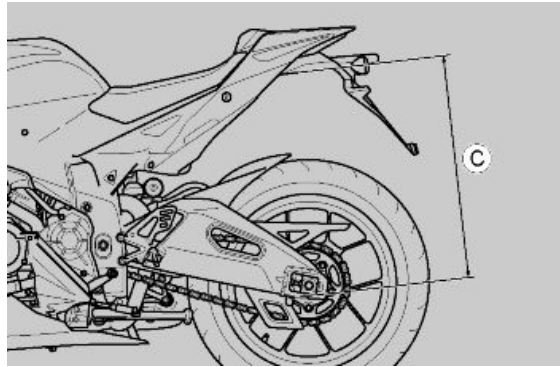


DO NOT LOOSEN THE LOCK NUT (5) AND THE ADJUSTER SCREW (6) BEYOND THE GROOVE ON THE SHOCK ABSORBER NEAR THE LOWER CONNECTION.

NOTE

TO CHECK FOR REAR FAILURE, MEASURE THE DIFFERENCE BETWEEN THE FOLLOWING TWO FIXED POINTS:

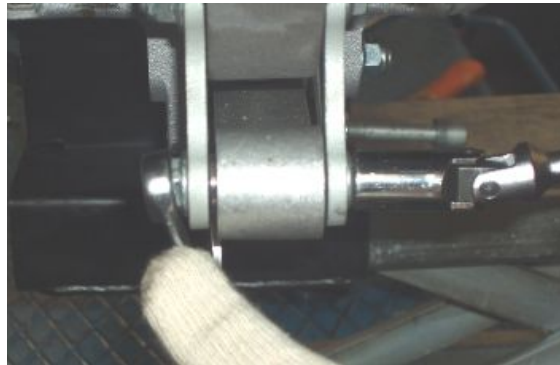
- CENTRE OF THE FRONT SCREW FASTENING THE LICENSE PLATE HOLDER TO UNDERTAIL SECTION AND
- UPPER CORNER OF THE SCREW FASTENING THE REAR STAND PIN ON THE SWING-ARM

**Removing**

- Secure the vehicle using a belt and hoist.
- Remove the silencer and the right hand rider footpeg.
- Unscrew and remove the lower screw and retrieve the nut.

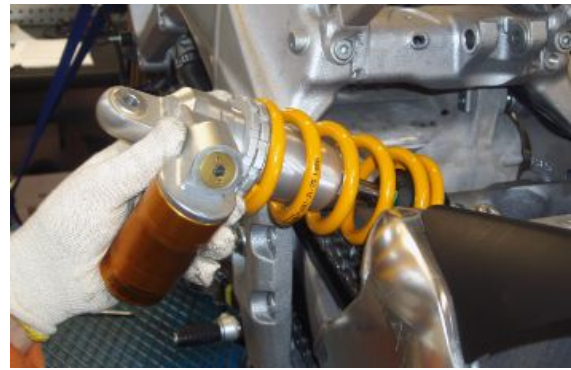


- Unscrew and remove the screw fixing the dual linkage rod to the single linkage.
- Retrieve the nut.



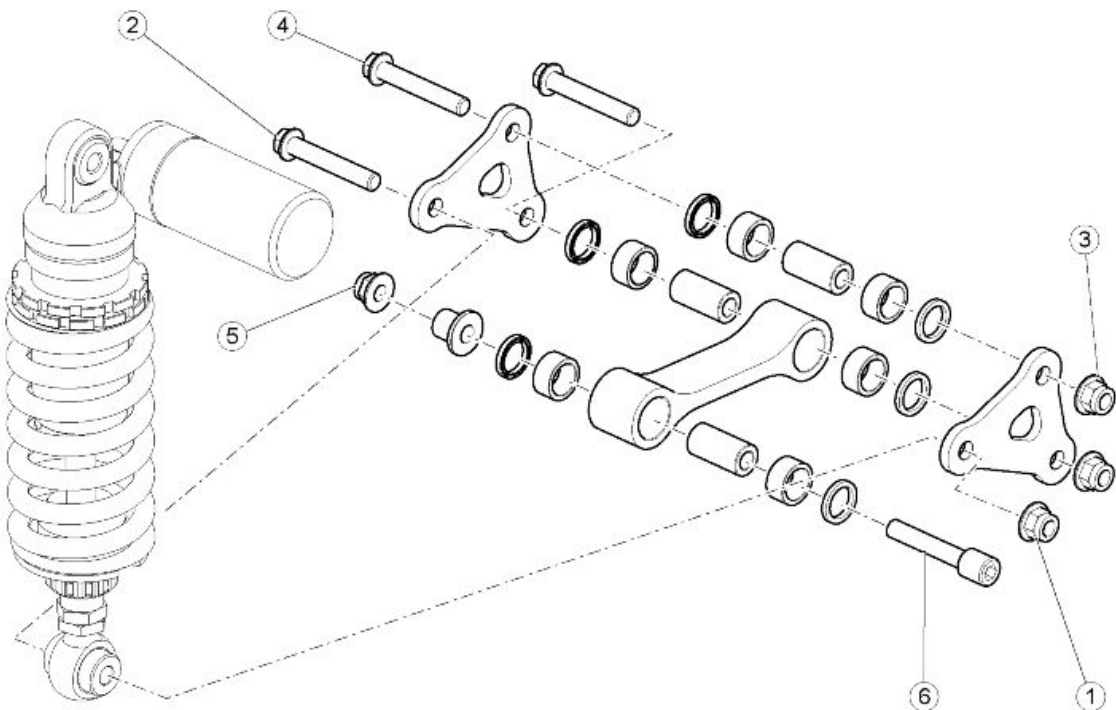
- Unscrew and remove the upper screw and retrieve the nut.
- Remove the shock absorber from the right side.





Linkages

Removing



- Working from the left side of the vehicle, loosen and remove the nut (1).
- Slide off the screw (2) from the opposite side.
- Loosen and remove the nut (3).
- Slide off the screw (4) from the opposite side.
- Loosen and remove the nut (5).
- Slide off the screw (6) from the opposite side.
- Remove the complete suspension connecting rod assembly unit.

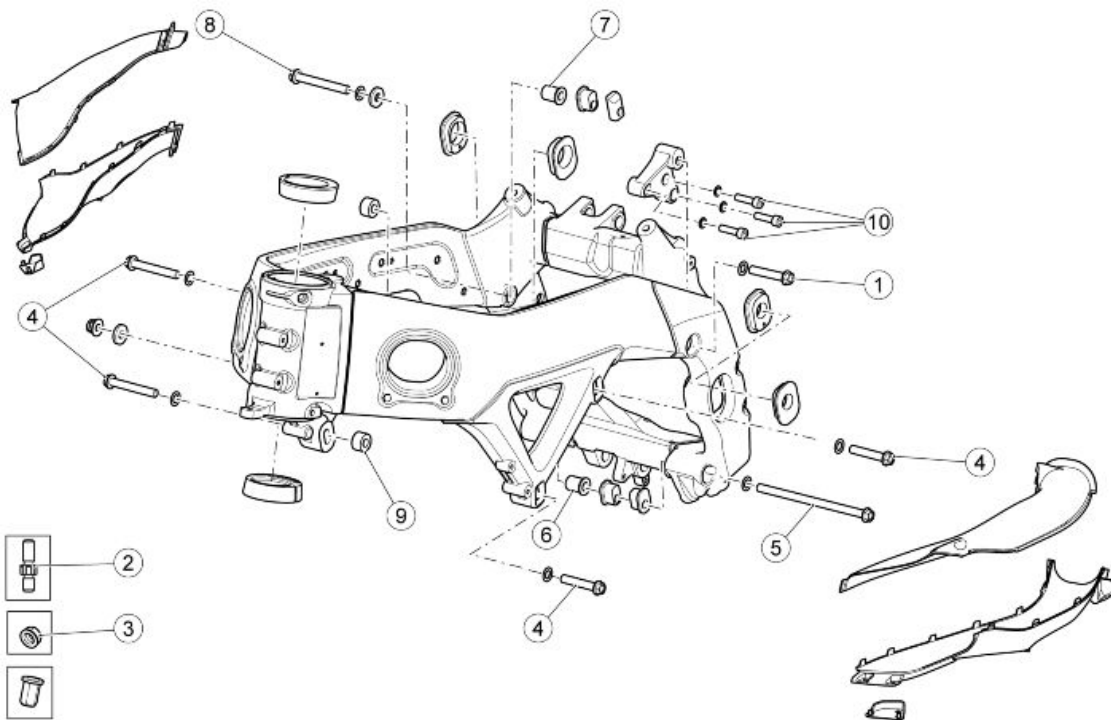
CAUTION

UPON REFITTING, GREASE THE FULCRUM POINTS ON THE CONNECTING ROD ASSEMBLY. PAY SPECIAL ATTENTION TO THE CORRECT POSITIONING OF THE PARTS AND CHECK SEVERAL TIMES THAT JOINTS MOVE SMOOTHLY.

INDEX OF TOPICS

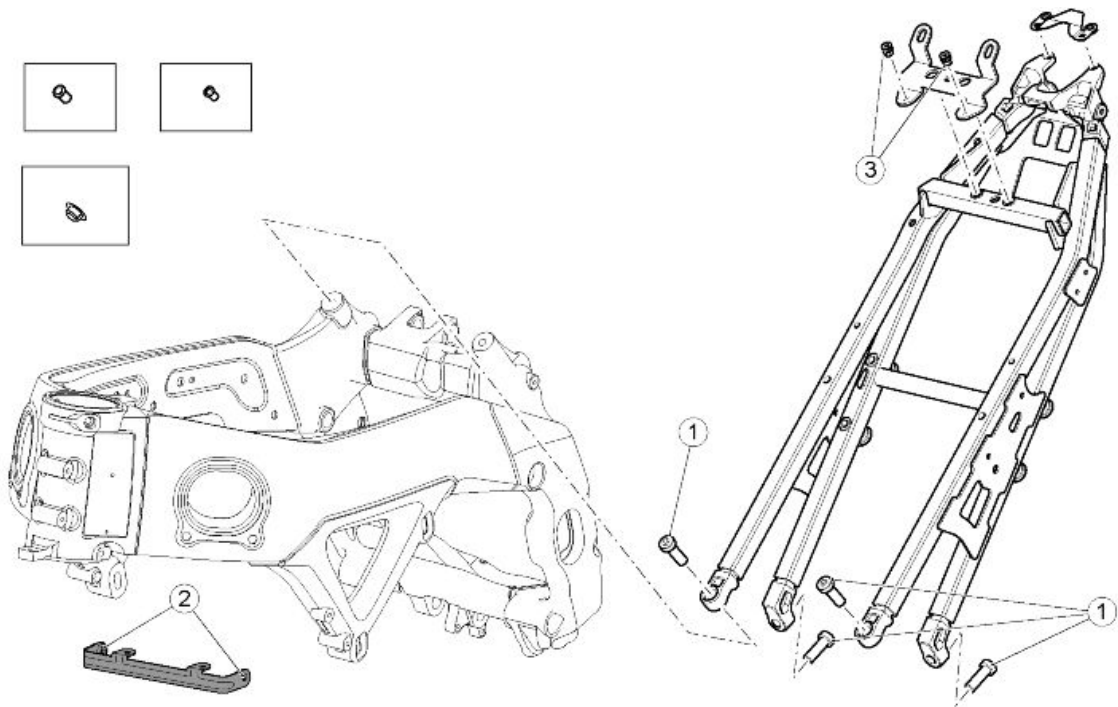
CHASSIS

CHAS



FRONT CHASSIS

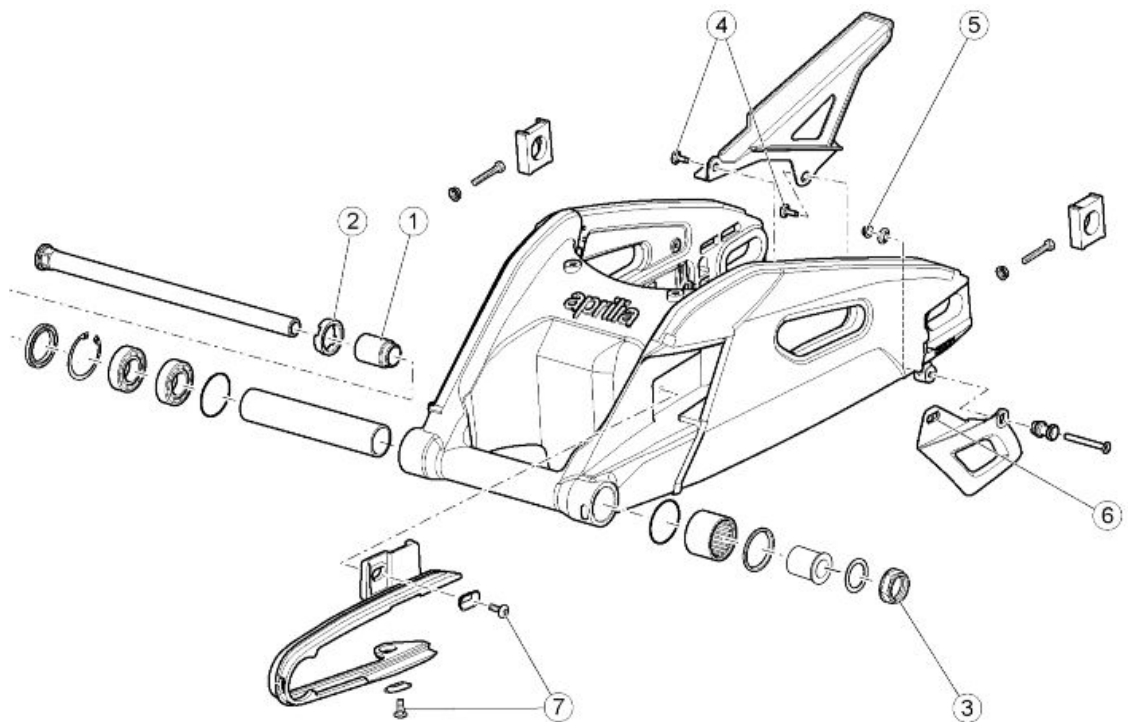
pos.	Description	Type	Quantity	Torque	Notes
1	Upper rear mount	M10	1	50 Nm (36.88 lbf ft)	-
2	Threaded intake duct fastener pins	M6	2 + 2	4 Nm (2.95 lbf ft)	Loct. 243
3	Intake duct fixing nuts	M6	2 + 2	Manual	-
4	Front mounts	M10	2 + 2	50 Nm (36.88 lbf ft)	-
5	Lower rear mount	M10	1	50 Nm (36.88 lbf ft)	-
6	Lower rear right hand adjuster screw bushing	M18x1.5	1	12 Nm (8.85 lbf ft)	-
7	Upper rear right hand adjuster screw bushing	M18x1.5	1	12 Nm (8.85 lbf ft)	-
8	Upper rear right hand mount	M10	1	50 Nm (36.88 lbf ft)	-
9	Right fairing spacer	M6	1	10 Nm (7.37 lbf ft)	Loct. 243
10	Upper rear left hand engine mount fastener screws	M8	3	25 Nm (18.44 lbf ft)	-
-	Screw fastening the ground cable to the left side chassis	M6	1	6 Nm (4.42 lbf ft)	-



REAR CHASSIS

pos.	Description	Type	Quantity	Torque	Notes
1	Saddle mounting fixing screws	M10	4	50 Nm (36.88 lbf ft)	-
2	Screws fastening oil radiator mounting bracket to engine	M6	2	8 Nm (5.9 lbf ft)	-
3	Passenger saddle and saddle cover catch plate fixing screws	M6	2	8 Nm (5.9 lbf ft)	-

Swinging arm



REAR SWINGARM

pos.	Description	Type	Quantity	Torque	Notes
1	Swingarm adjuster screw bushing	M30x1.5	1	12 Nm (8.85 lbf ft)	-
2	Swingarm ring nut	M30x1.5	1	60 Nm (44.25 lbf ft)	-
3	Swingarm pin nut	M20x1.5	1	65 Nm (47.94 lbf ft)	AGIP GREASE SM2
4	Chain casing fixing screws	M5	2	4 Nm (2.95 lbf ft)	-
5	Front chain guide fixing screw	M5	1	4 Nm (2.95 lbf ft)	-
6	Rear chain guide fixing nut	M6	1	7 Nm (5.16 lbf ft)	-
7	Chain skid fixing screws	M5	2	2 Nm (1.47 lbf ft)	-
-	Lower chain slider fixing screws	M6	2	10 Nm (7.37 lbf ft)	-
-	Chain guide fixing screw	M6	1	8 Nm (5.90 lbf ft)	-

Removing

- Remove the exhaust system.
- Remove the rear mudguard.
- Remove the rear shock absorber.
- Remove the rear wheel.
- Secure the rear part of the vehicle with a belt and a hoist.
- Unscrew and remove the two pipe grommet screws.
- Remove the rear brake calliper off the swingarm.



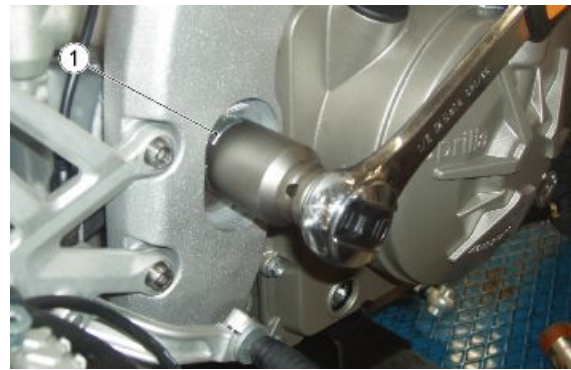
- Unscrew and remove the screw and retrieve the washer.
- Slide off the pinion from the chain and remove.



- Unscrew and remove the nut and retrieve the washer.



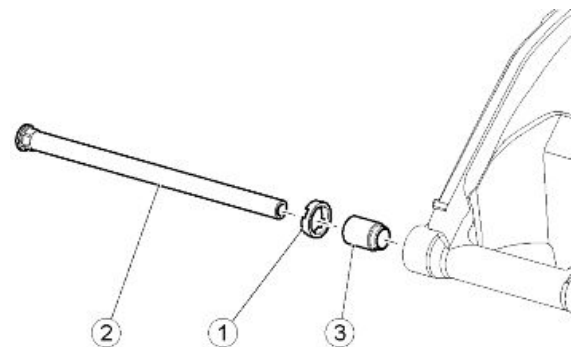
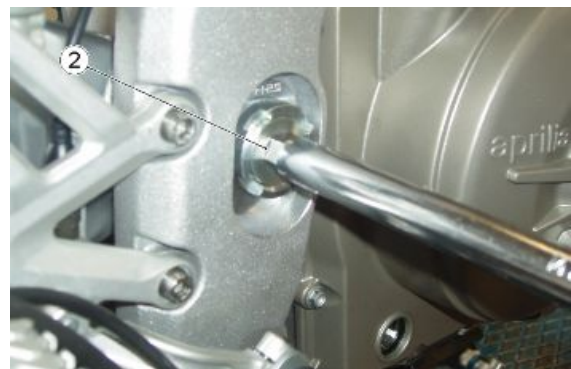
- Working from the right side, loosen and remove the locking ring nut.



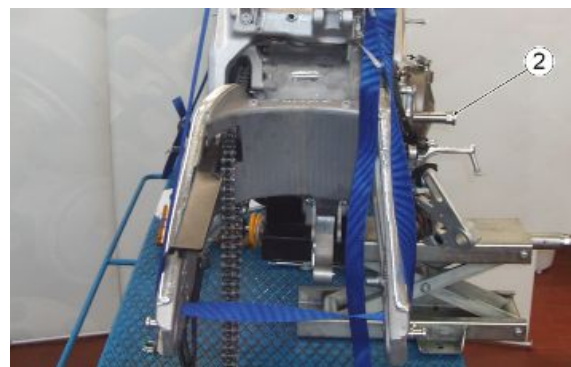
- Turn the swingarm pin (2) anticlockwise, which turns and loosens the adjustment bushing (3) completely.



REMOVAL SHOULD BE CARRIED OUT WITH UTMOST CAUTION. SUPPORT THE SWINGARM FROM THE FRONT TO AVOID ACCIDENTAL FALLS. PLACE A WOODEN SUPPORT UNDER THE FRONT PART OF THE REAR SWINGARM TO PREVENT IT FROM LOWERING AND TO KEEP IT UPRIGHT.



- Place a mounting under the front part of the swingarm.
- Support the swingarm from the front.
- Remove the swingarm pin (2) from the right hand side.
- Support the front part of the swingarm and be ready to accompany it.
- Using the rear mounting stand, remove the swingarm completely from the vehicle from the rear.



- Remove the adjustment bushing from the swingarm pin (2).



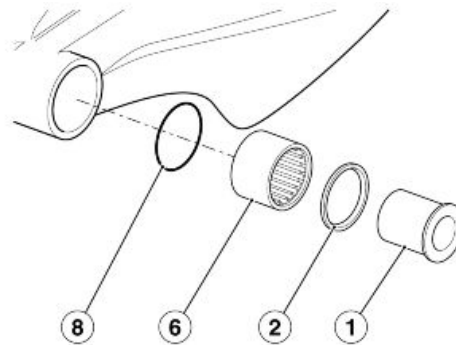
UPON REMOVING THE REAR SWINGARM PAY ATTENTION NOT TO JAM THE GEARING CHAIN.

- If necessary, use a specific tool to remove a pin from the drive chain.
- Open and remove the chain.



Checking

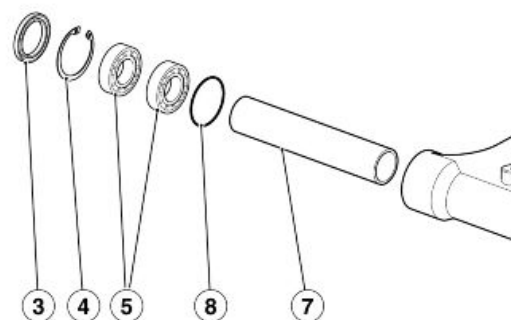
- Remove the swingarm.
- Clean the two sides of the bearing seats with a cloth.
- Slide off the bushing (1).
- Remove the sealing gasket (2).
- Remove the sealing gasket (3).
- Remove the circlip (4).
- Use the specific special tool to extract the two bearings (5) and the roller bearing (6).



CHECK AND, IF REQUIRED, REPLACE THE BEARINGS AFTER EVERY BEARING REMOVAL.

Specific tooling

AP8140180 Extractor for bushings



- Remove the inner spacer (7) and collect the two OR seals (8).
- Carefully clean inside the bearing seat.

CAUTION

WASH ALL THE PARTS WITH CLEAN DETERGENT.



UPON REFITTING, USE A BUFFER WITH A DIAMETER EQUAL TO THE EXTERNAL RING OF THE BEARINGS TO INSERT THE BEARINGS.

DO NOT HIT THE BALLS AND/OR THE INTERNAL RING.



CHECK THAT ALL PARTS ARE IN GOOD CONDITION, ESPECIALLY THOSE LISTED AS FOLLOWS.

SWINGARM BEARINGS

Carry out the check with the bearings fitted on the swingarm.

ROTATION CHECK

- Manually rotate the inside ring of each bearing. Rotation must be constant, smooth and noiseless.

If one or both bearings do not fall within the control parameters:

- Replace both swingarm bearings.

RADIAL AND AXIAL CLEARANCE CHECK

- Check the radial and axial clearance.

Axial clearance: a minimum axial clearance is allowed.

Radial clearance: none.

If one or both bearings do not fall within the control parameters:

- Replace both swingarm bearings.



ALWAYS REPLACE BOTH BEARINGS.

ALWAYS REPLACE THE BEARINGS WITH OTHERS OF THE SAME TYPE.

SWINGARM SEALS

- Check that the gaskets are in good conditions; replace them if they show signs of damage or excessive wear.



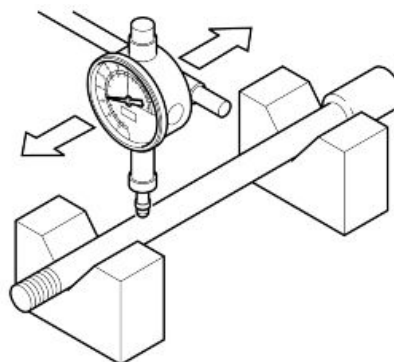
ALWAYS REPLACE BOTH GASKETS.

ALWAYS REPLACE THE GASKETS WITH OTHERS OF THE SAME TYPE.

SWINGARM PIN

- Use a dial gauge to check the swingarm pin eccentricity. If the eccentricity exceeds the limit value, replace the swingarm pin.

Maximum eccentricity: 0.3 mm (0.012 in)

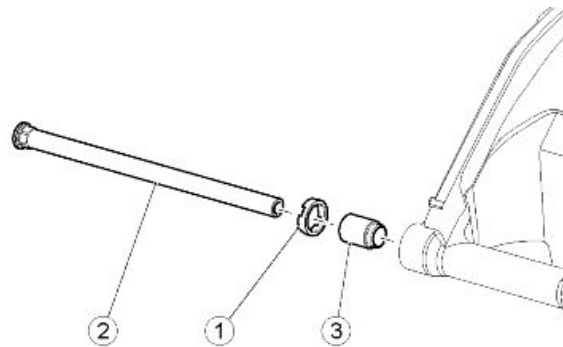


Installing

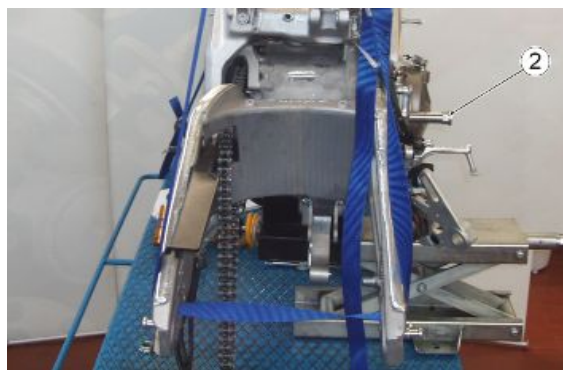
- Spread a thin layer of lubricating grease all along the swingarm pin.
- Fit the adjustment bushing (3) to its seat and tighten it manually.

CAUTION

THE ADJUSTMENT BUSHING (3) MUST NOT PROTRUDE BEYOND THE CHASSIS INTERNAL EDGE.



- Place a wooden support under the front of the swingarm to prevent it from dropping and hold in position.
- Support the swingarm from the front; move it into position so that the holes are aligned and simultaneously insert the pin (2) fully.
- Ensure that the hexagonal area on the pin head (2) is inserted correctly in the hexagonal seat inside the adjustment bushing (3).
- Fit and hand-tighten the counter-lock ring nut by a few turns (1).



- Put some grease on the swingarm pin nut as indicated

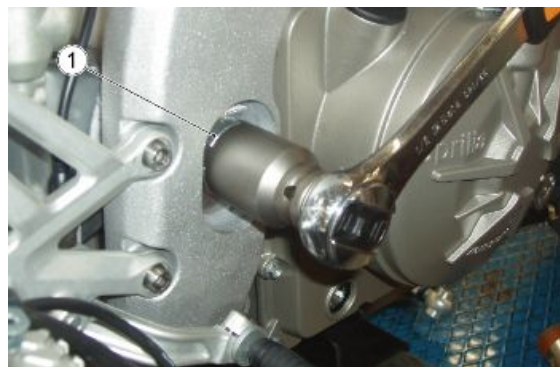


- Fit the washer and the swingarm pin fixing nut on the pin and hand-tighten the nut.

- Working from the right hand side of the vehicle, turn the swingarm pin (2) clockwise. This turns the adjustment bushing (3), driving the swingarm in until fully seated.



- Tighten the locking ring nut (1).



- Screw the nut.



- Refit the chain on the drive pinion

CAUTION

APPLY LOCTITE ANTI-SEIZE ON THE INTERNAL TOOTHING OF THE TRANSMISSION PINION.



- Fit the pinion and the chain on the shaft.

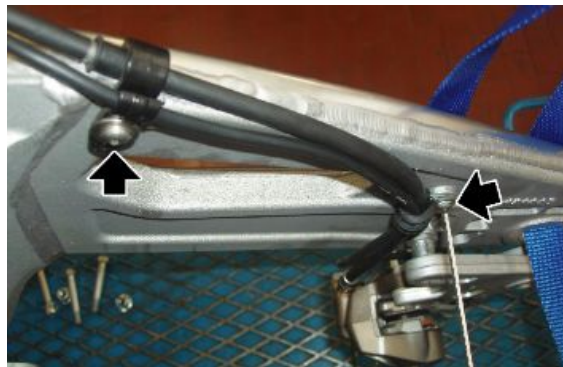
CAUTION

APPLY LOCTITE 243 ON THE SCREW THREAD.

- Fit the washer on the screw
- Tighten the screw.



- Install the rear shock absorber and the linkages.
- Fit the rear brake calliper plate.
- Fasten the two pipe grommets on the swingarm



- Install the rear wheel and the exhaust system.
- Fit the pinion casing.
- Adjust the chain tension

Drive chain

Adjusting

The vehicle is fitted with an endless chain, without master link.

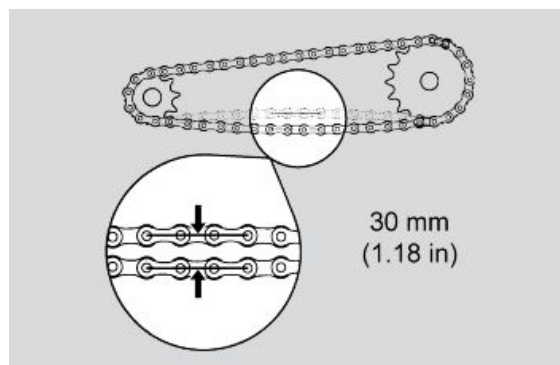
NOTE

CARRY OUT MAINTENANCE OPERATIONS AT HALF THE INTERVALS SPECIFIED IF THE VEHICLE IS USED IN PARTICULAR RAINY OR DUSTY CONDITIONS, OFF ROAD OR FOR TRACK USE.

CLEARANCE CHECK

To check clearance:

- Shut off the engine.
- Rest the vehicle on its stand.
- Engage neutral gear.
- Check that the vertical oscillation at a point between the pinion and the sprocket on the lower branch of the chain is around 30 mm (1,18 in).



- Move the vehicle forward so as to check vertical oscillation in other positions too. clearance should remain constant at all wheel rotation phases.

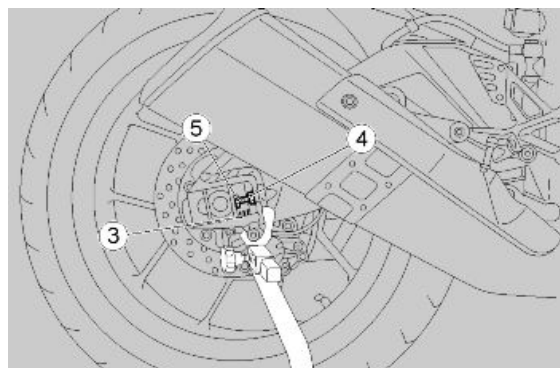
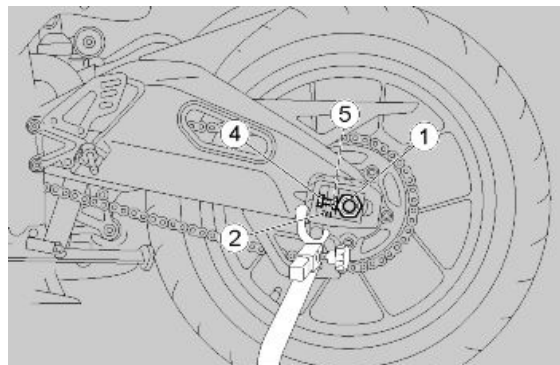
ADJUSTMENT

CAUTION

GET A SPECIFIC REAR SERVICE STAND (OPT) TO ADJUST THE CHAIN.

If you need to adjust chain tension after the check:

- Place the vehicle on its rear service stand (OPT).
- Loosen the nut (1) completely.
- Loosen both lock nuts (4).
- Actuate on the adjuster screws (5) and adjust the chain clearance checking that the references (2-3) match on both sides of the vehicle.
- Tighten both lock nuts (4).
- Tighten the nut (1).
- Check chain clearance.



CAUTION

TO ENSURE THAT THE WHEEL IS CORRECTLY CENTRED, THERE ARE FIXED REFERENCE MARKINGS (2-3) INSIDE THE CHAIN TENSIONER SLIDER SEATS ON THE SWINGARMS, IN FRONT OF THE WHEEL AXLE.

CHECKING THE CHAIN, THE PINION AND THE SPROCKET FOR WEAR

Furthermore, check the following parts and make sure the chain, the pinion and the sprocket do not show:

- damaged rollers;
- loosened pins;
- dry, rusty, flattened or jammed chain links;
- excessive wear;
- missing sealing rings;
- excessively worn or damaged pinion or sprocket teeth.



IF THE CHAIN ROLLERS ARE DAMAGED, THE PINS ARE LOOSE AND/OR THE SEAL RINGS ARE MISSING OR DAMAGED, THE WHOLE CHAIN UNIT (PINION, SPROCKET AND CHAIN) SHOULD BE REPLACED.

LUBRICATE THE CHAIN ON A REGULAR BASIS, PARTICULARLY IF YOU DETECT DRY OR RUSTY PARTS.

FLATTENED OR JAMMED CHAIN LINKS SHOULD BE LUBRICATED AND GOOD OPERATING CONDITIONS RESTORED.



THE GEARING CHAIN HAS SEALING RINGS AMONG THE LINKS THAT KEEP THE GREASE INSIDE.

ADJUST, LUBRICATE, WASH AND REPLACE THE CHAIN WITH UTMOST CAUTION.

CLEANING AND LUBRICATION

Do not wash the chain with water jets, steam jets, high-pressure water jets and highly flammable solvents.

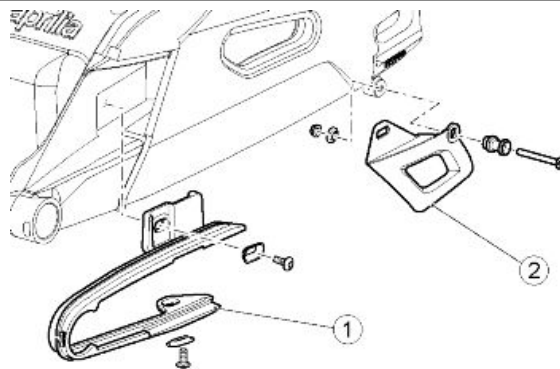
- Wash the chain with fuel oil or kerosene. Maintenance operations should be more frequent if there are signs of quick rust.

Lubricate the chain at the intervals specified on the routine maintenance table and whenever necessary.

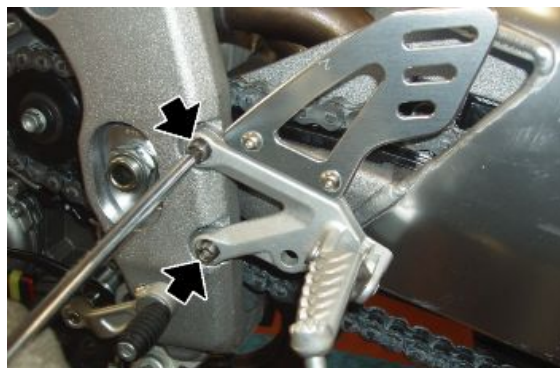
- Wash the chain, allow to dry and lubricate with spray grease for sealed chains.

Chain sliders

- Place the vehicle on its OPTIONAL rear service stand.
- Check that the pad (1) is not worn or damaged. Replace it with a new one if it is.
- Check the chain guide (2) for wear.



- Unscrew and remove the two screws from the left rider footpeg protection.



- Remove the rear wheel.

- Unscrew and remove the upper screw fixing the chain slider and retrieve the washer.

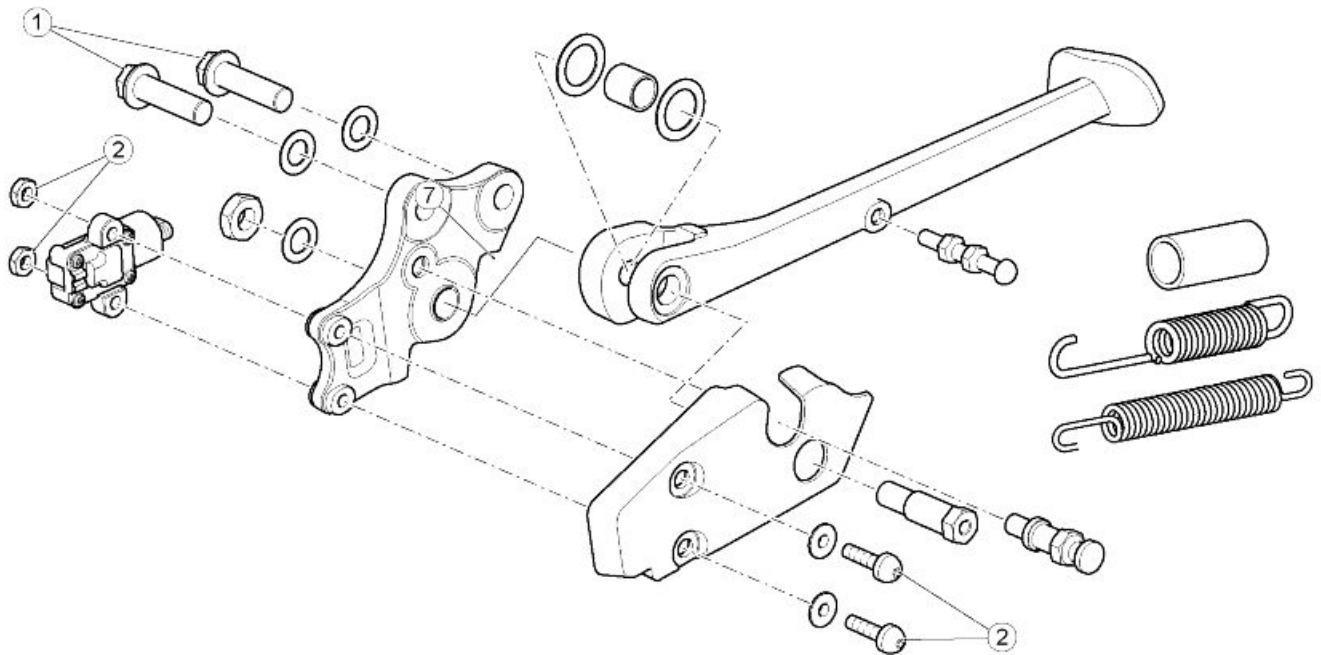


- Unscrew and remove the lower screw fixing the chain pad and retrieve the washers.



- Remove the chain skid (1).

Stand



SIDE STAND

pos.	Description	Type	Quantity	Torque	Notes
1	Screws fastening the stand to the chassis	M10	2	45 Nm (33.19 lbf ft)	Loct. 243
2	Linear switch retainer	M5	2	4 Nm (2.95 lbf ft)	-
-	Rear stand bushing fastening screws	M6	2	7 Nm (5.16 lbf ft)	-

Side stand

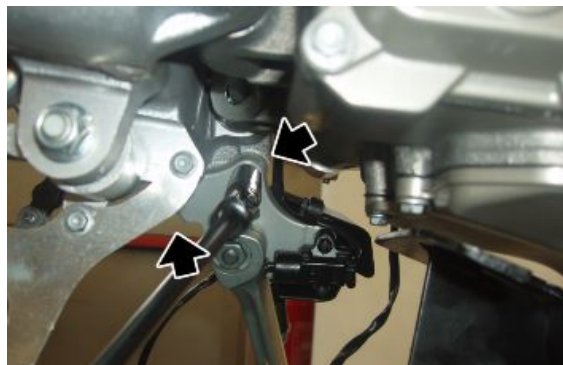
- Remove the clamp.



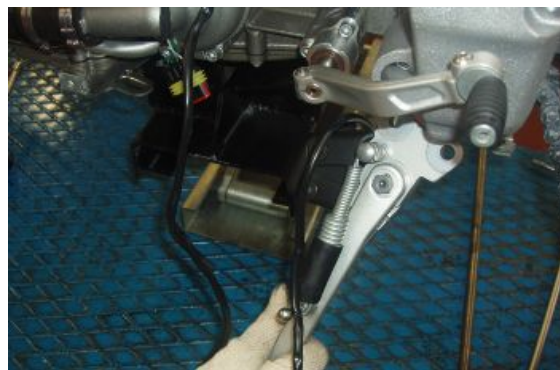
- Disconnect the stand connector.



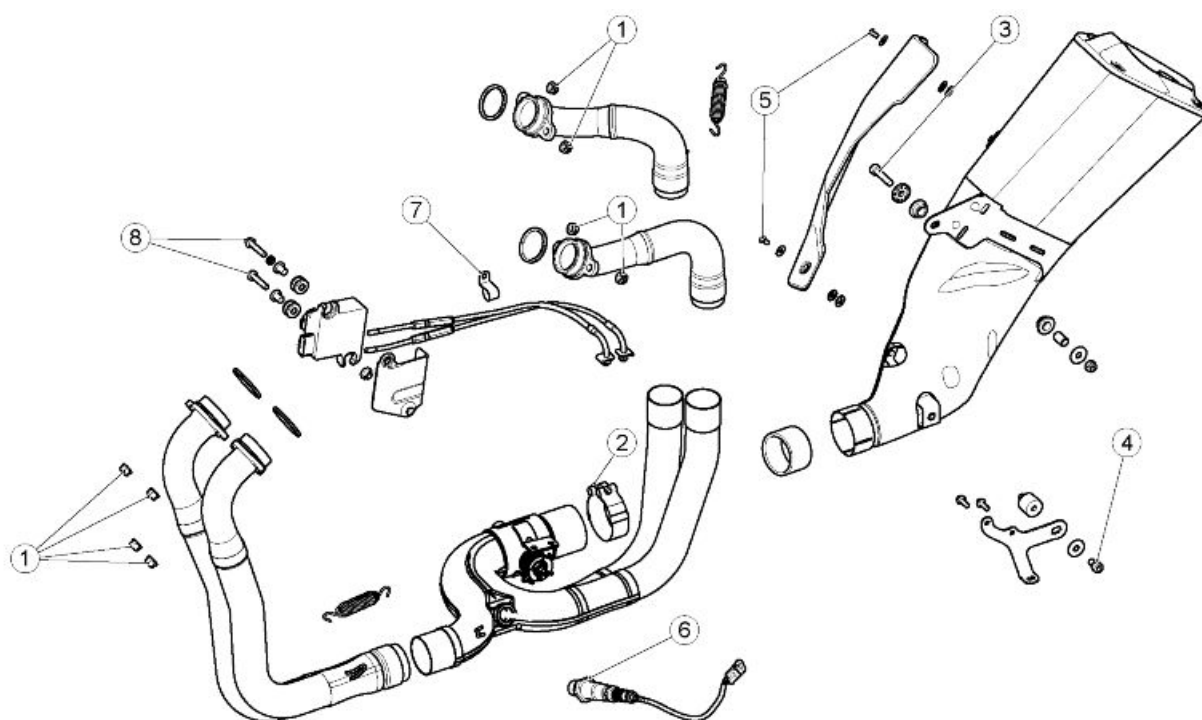
- Unscrew and remove the two screws.



- Remove the side stand.



Exhaust



EXHAUST

pos.	Description	Type	Quantity	Torque	Notes
1	Exhaust manifold flange fixing nuts	M7	8	13 Nm (9.59 lbf ft)	-
2	Silencer clamp fixing screw	M6	1	10 Nm (7.37 lbf ft)	-
3	Screw fastening silencer to right hand footpeg mounting	M8	1	25 Nm (18.44 lbf ft)	-
4	Screw fastening silencer to central lower fairing bracket	M8	1	20 Nm (14.75 lbf ft)	-
5	Cosmetic silencer shield fixing screw	M5	2	5 Nm (3.69 lbf ft)	-
6	Oxygen sensor fastener	M18x1.5	1	38 Nm (28.03 lbf ft)	-
7	Fastener screw for cable grommet for exhaust butterfly valve cables	M6	1	10 Nm (7.37 lbf ft)	-
8	Exhaust butterfly valve actuator fixing screws	M6	2	10 Nm (7.37 lbf ft)	-

Removing the tail pipe

- Loosen the sealing clamp between the exhaust and the central manifold.



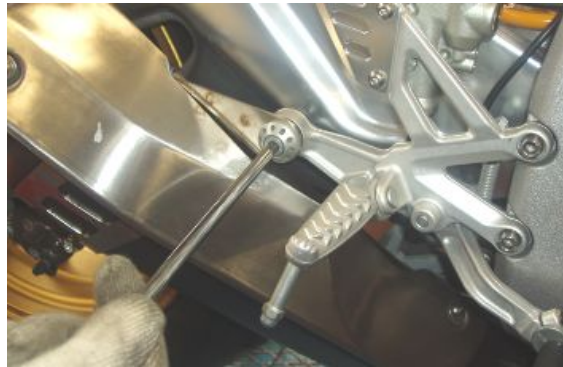
- Unscrew and remove the front screw fastening the exhaust to the chassis.



- Unscrew and remove the upper attachment screw fixing the exhaust pipe to the chassis; retrieve the collar, the washer and the nut.



DURING THIS OPERATION SUPPORT THE EXHAUST PIPE SO THAT IT DOES NOT FALL.

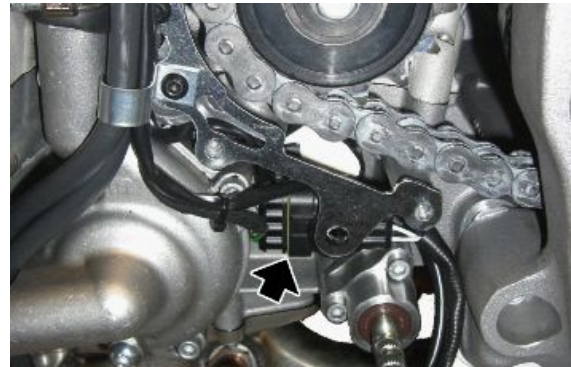


- Remove the exhaust end.

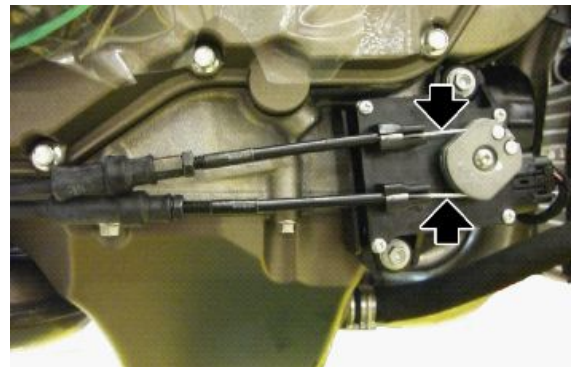


Removing the catalytic converter

- Remove the exhaust end.
- Remove the front exhaust manifold.
- Remove the pinion crankcase
- Disconnect the lambda sensor connector.
- Release the oxygen sensor cable harness from the clamps.



- Disconnect the two exhaust butterfly valve control cables



- Unscrew and remove the screw from the cable grommet for the two exhaust butterfly valve control cables.

CAUTION

ON REASSEMBLY, POSITION AND TIGHTEN THE SCREW BUT NOT THE CABLE GROMMET.



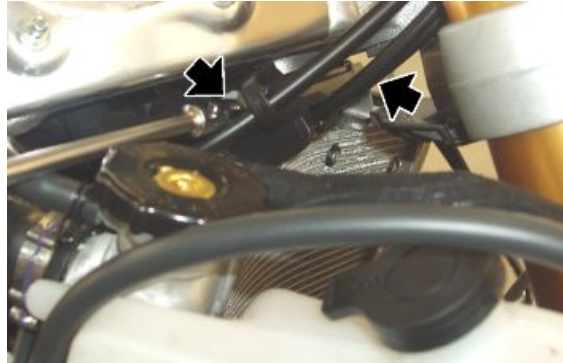
- Release the springs between the rear exhaust manifolds and the catalytic converter
- Remove the catalytic converter.



Removing the exhaust manifold

2 IN 1 FRONT EXHAUST MANIFOLD

- Remove the front underfairings.
- Remove the hand grip position sensor control unit.
- Unscrew and remove both radiator upper fixing screws.



See also

[Fairing mounting panels](#)
[Twistgrip position sensor](#)

- Release the springs between the front exhaust manifolds and the catalytic converter



- Move the radiator forward.
- Unscrew and remove the four nuts fastening the front exhaust manifold and retrieve the washers.



- Remove the front exhaust manifold.



REAR EXHAUST MANIFOLDS

- Remove the catalytic converter.
- Remove the left rider footpeg.
- Unscrew and remove the four nuts fastening the rear exhaust manifolds and retrieve the washers.
- Remove both rear exhaust manifolds.

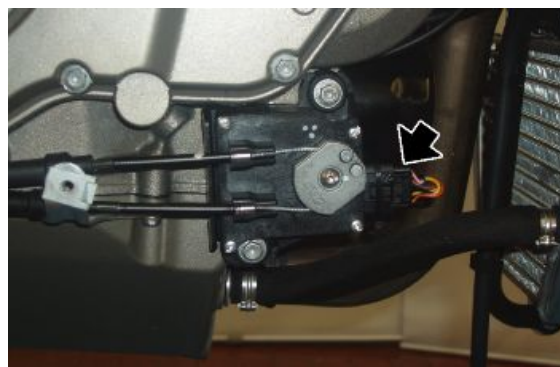


Butterfly valve in exhaust

To check correct operation and calibration of the exhaust valve, see electrical system section.

REMOVING THE EXHAUST THROTTLE VALVE

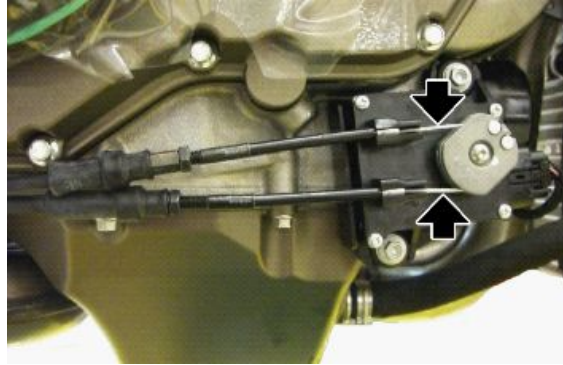
- Remove the fairing lug.
- Disconnect the connector from the valve actuator motor.



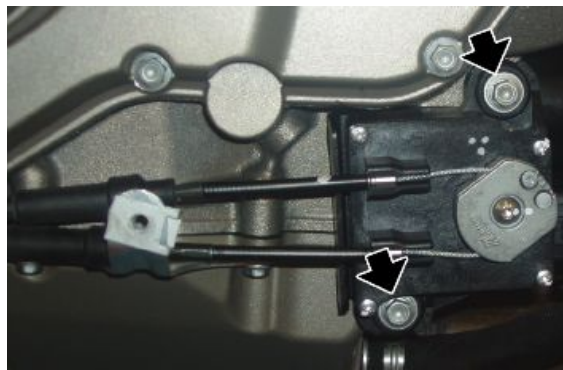
See also

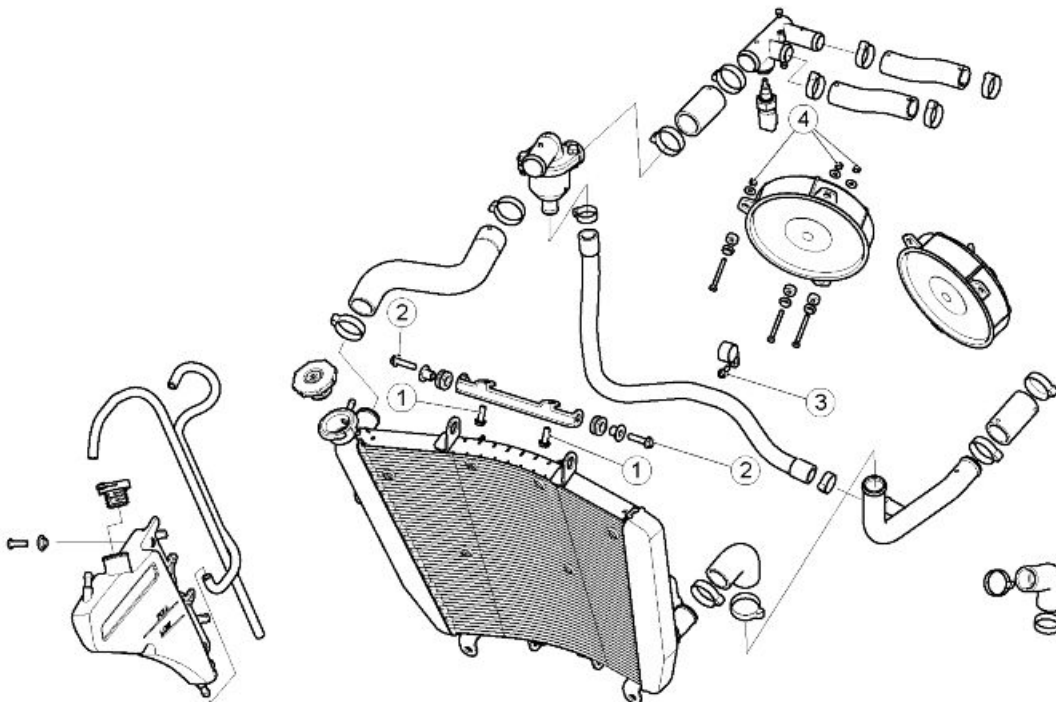
Lower cowl

- Disconnect the two exhaust butterfly valve control cables



- Unscrew and remove the two valve actuator motor screws
- Remove the valve actuator motor together with the heat shield.



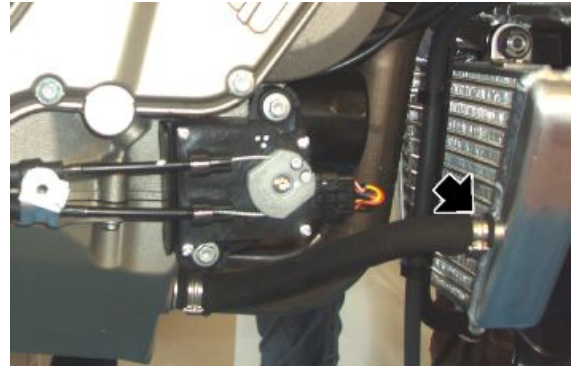
Engine oil cooler

OIL RADIATOR

pos.	Description	Type	Quantity	Torque	Notes
1	Screws fastening oil radiator to mounting bracket	M6	1	7 Nm (5.16 lbf ft)	-

Removing

- Drain the engine oil.
- Remove both fairings and the radiator cowl.
- Release the clamp and disconnect the right hand radiator pipe.



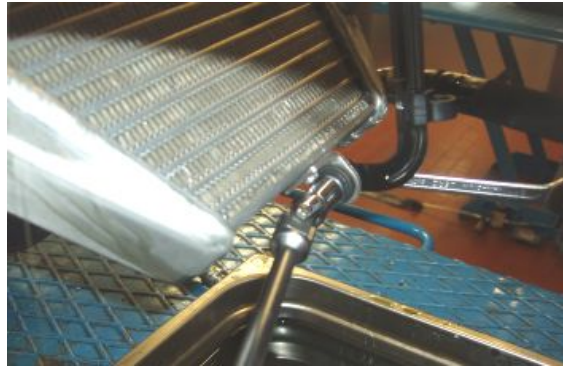
- Release the clamp and disconnect the left hand radiator pipe.

**See also**[Replacement](#)

- Remove the split pin.
- From the opposite site, remove the coolant radiator-oil radiator connector pin.



- Unscrew and remove the lower radiator retainer.
- Remove the radiator, draining completely of oil.

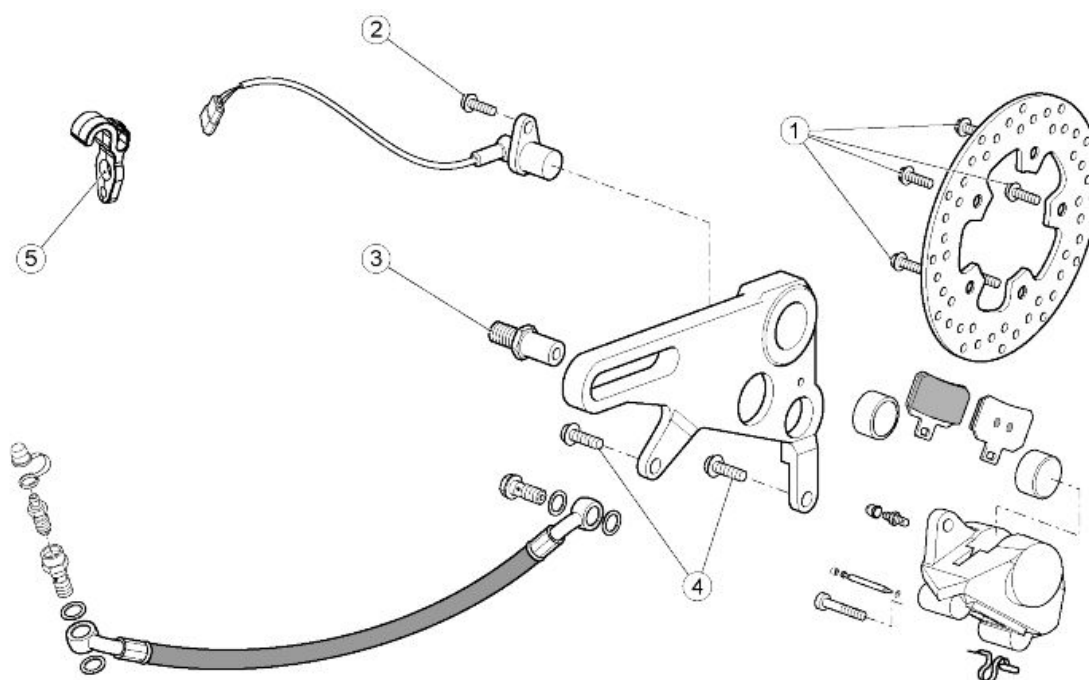


INDEX OF TOPICS

BRAKING SYSTEM

BRAK SYS

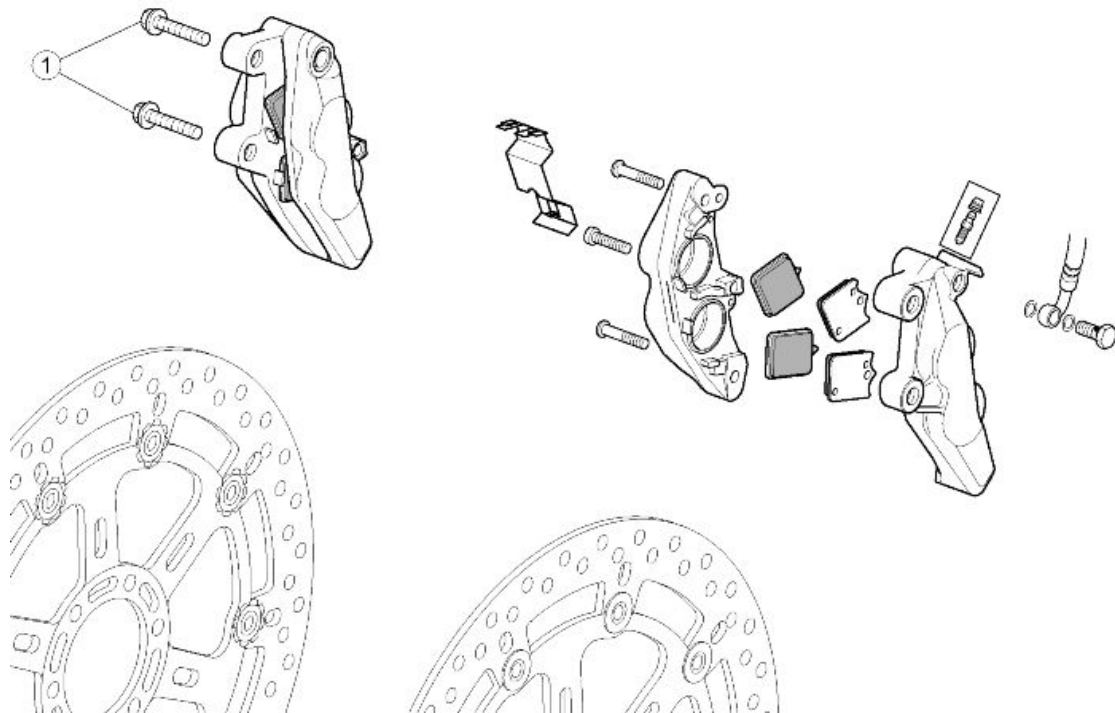
Rear brake calliper



REAR BRAKE CALLIPER

pos.	Description	Type	Quantity	Torque	Notes
1	Rear brake disc fixing screws	M8	5	30 Nm (22.13 lbf ft)	Loct. 243
2	Screw fastening odometer sensor onto rear brake calliper mounting	M6	1	12 Nm (8.85 lbf ft)	-
3	Rear brake calliper mounting plate lock pin	M12	1	50 Nm (36.88 lbf ft)	Loct. 243
4	Rear calliper fixing screw	M5	2	25 Nm (18.44 lbf ft)	-
5	Brake pipe clamp fixing screw	M5	2	4 Nm (2.95 lbf ft)	-
-	Brake pipe bracket fixing screw	M5	2	4 Nm (2.95 lbf ft)	-

Front brake calliper



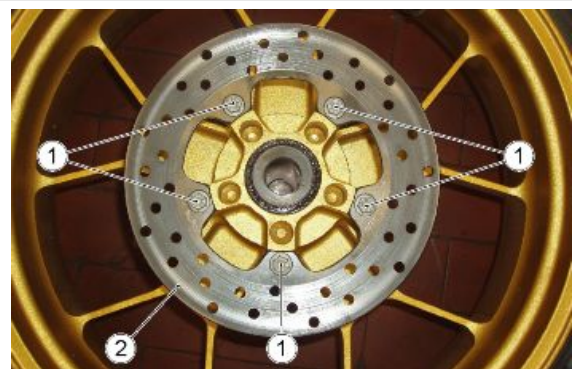
FRONT BRAKE CALLIPER

pos.	Description	Type	Quantity	Torque	Notes
1	Front brake calliper fixing screws	M10x1.25	2 + 2	50 Nm (36.88 lb ft)	-

Rear brake disc

Removal

- Remove the rear wheel.



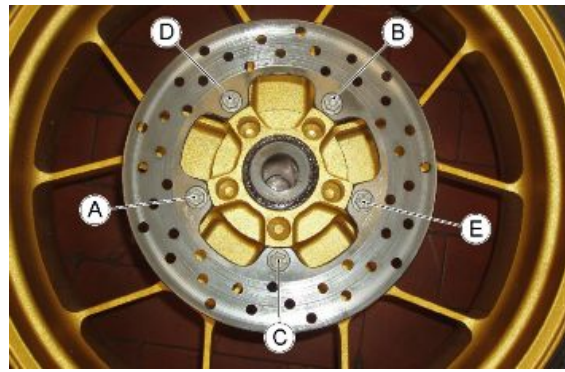
- Unscrew and remove the five brake disc screws (1).
- Remove the brake disc (2).



DURING REFITTING, APPLY LOCTITE 243 ON THE THREAD OF THE BRAKE DISC SCREWS (1).

CAUTION

UPON REFITTING, TIGHTEN ALL THE SCREWS (1) MANUALLY AND FASTEN THEM OPERATING DIAGONALLY FOLLOWING THIS SEQUENCE: A-B-C-D-E.



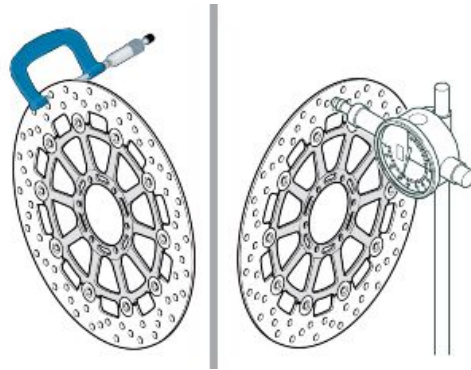
See also

[Removing the rear wheel](#)

Disc Inspection

The operations must be carried out with the brake disc fitted on the wheel.

- Check the disc for wear by measuring the minimum thickness with a micrometer in different points.
- If the minimum thickness, even in a single point of the disc, is less than the minimum value, replace the disc.



Disc thickness minimum value: 4.5 mm (0.18 in)

- Using a dial gauge, check that the maximum oscillation of the disc does not exceed the tolerance; otherwise, replace it.

Disc oscillation tolerance: 0.1 mm (0.0039 in)

Front brake disc

Removal

- Remove the front wheel.

The following operations refers to a single disc but apply to both.

To unscrew the screws (1), use an air screwer gun to give a clean blow, which will detach the screws stuck with LOCTITE 243.

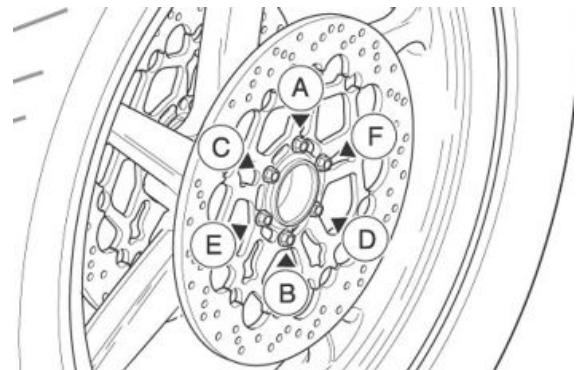
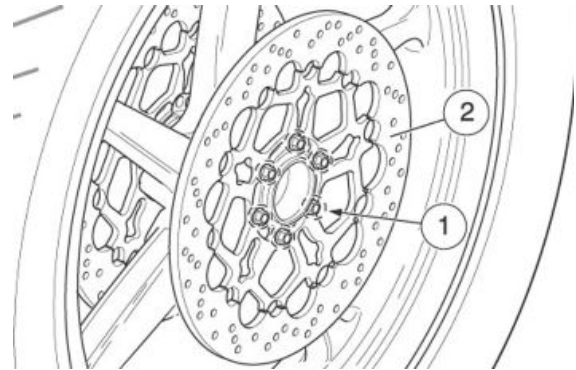
- Unscrew and remove the six brake disc screws (1).
- Remove the brake disc (2).



UPON REFITTING, APPLY LOCTITE 243 ON THE THREAD OF THE BRAKE DISC SCREWS (1).

CAUTION

UPON REFITTING, SCREW ALL THE SCREWS (1) MANUALLY AND TIGHTEN THEM OPERATING DIAGONALLY FOLLOWING THIS SEQUENCE: A-B-C-D-E-F.



See also

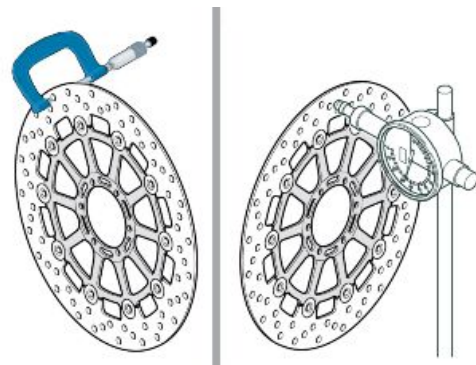
[Removing the front wheel](#)

Disc Inspection

- The following operations must be carried out with the brake discs fitted on the wheel; they refer to a single disc, but are valid for both.
- Check the disc for wear by measuring the minimum thickness with a micrometer in different points. If the minimum thickness, even in a single point of the disc, is less than the minimum value, replace the disc.

Disc thickness minimum value: 4 mm (0.16 in)

- Using a dial gauge, check that the maximum oscillation of the disc does not exceed the tolerance; otherwise, replace it.



Disc oscillation tolerance: 0.15 mm (0.0059 in)

Front brake pads

Removal



THIS VEHICLE IS FITTED WITH A DOUBLE DISC FRONT BRAKING SYSTEM (RIGHT AND LEFT SIDE).

ALWAYS REPLACE ALL THE PADS FROM BOTH FRONT BRAKE CALLIPERS.

REPLACING THE PADS OF ONLY ONE FRONT CALLIPER MAY JEOPARDISE THE VEHICLE STABILITY AND SAFETY, POSING SERIOUS DANGER FOR PEOPLE, OBJECTS AND THE VEHICLE ITSELF.

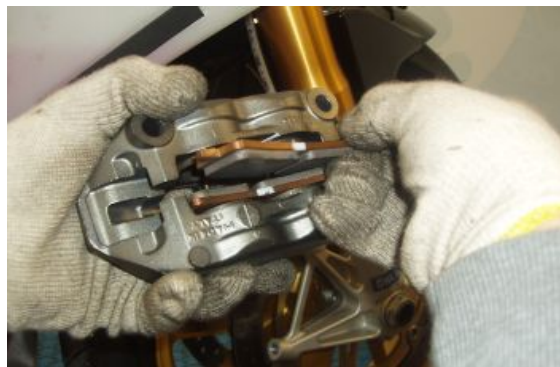
CAUTION

THE FOLLOWING OPERATIONS REFER TO A SINGLE CALLIPER, BUT APPLY TO BOTH.

- Unscrew and remove the two screws (1).
- Slide off the disc from the front brake calliper.



- Separate the brake calliper pistons.
- Remove the pads from the brake calliper.
- Retrieve the clip.



AFTER REMOVING THE PADS, DO NOT OPERATE THE BRAKE CONTROL LEVER OR THE CALLIPER PLUNGERS COULD GO OUT OF THEIR SEATS RESULTING IN BRAKE FLUID LEAKAGE.

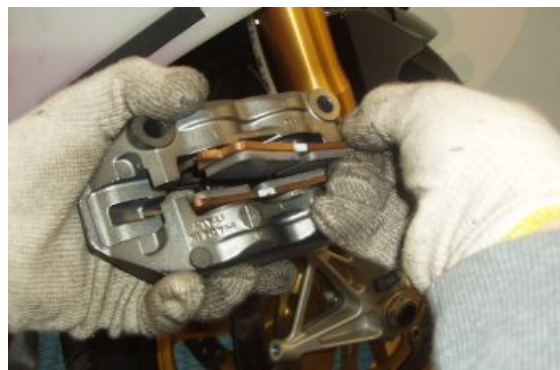
Installing

- An arrow is stamped on the brake calliper and on the clip, which must always point in the direction of rotation of the front wheel.
- Fit the clip in the brake calliper.

- Fit the two new pads in the correct position.



ALWAYS REPLACE THE FOUR PADS AND MAKE SURE THEY ARE CORRECTLY POSITIONED INSIDE THE CALIPER.



- Fit the front brake calliper on the disc.
- Hand-tighten the two screws (1) fully.
- Pull the front brake lever to seat the brake calliper correctly.
- Tighten the two screws (1).
- Check the front brake fluid level.



Rear brake pads

Removal

- Rest the vehicle on its stand.
- Remove the rear brake calliper.

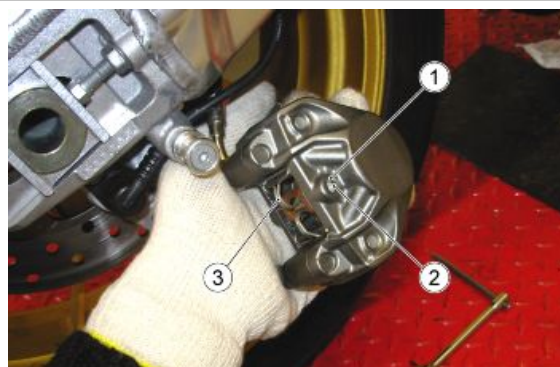
CAUTION

DO NOT ACTUATE ON THE REAR BRAKE LEVER AFTER REMOVING THE WHEEL, OTHERWISE THE CALLIPER PLUNGER COULD GO OUT OF ITS SEAT, RESULTING IN BRAKE FLUID LEAKAGE.

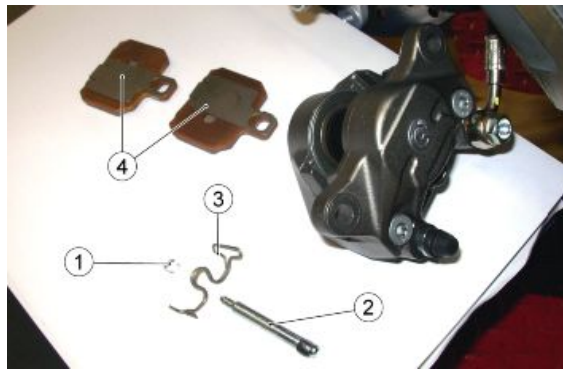
- Remove the snap ring (1).



BEFORE REMOVING THE PIN (2), CHECK THAT THE SAFETY SPRING (3) IS CORRECTLY POSITIONED; WHEN REFITTED, IT MUST BE POSITIONED IN THE SAME WAY.



- Remove the pin (2) and retrieve the safety spring (3).
- Extract the two pads (4) and retrieve the noise damping plates.
- If worn, replace the vibration damping plates.



AFTER REMOVING THE PADS, DO NOT OPERATE THE BRAKE CONTROL LEVER OR THE CALLIPER PLUNGERS COULD GO OUT OF THEIR SEATS RESULTING IN BRAKE FLUID LEAKAGE.

Installing

- Insert two new pads and the vibration-damping plates, placing them so that the holes are aligned with the calliper holes.



UPON REFITTING, MAKE SURE THE ARROWS ON THE VIBRATION-DAMPING PLATES FACE THE DIRECTION OF ROTATION OF THE WHEEL.

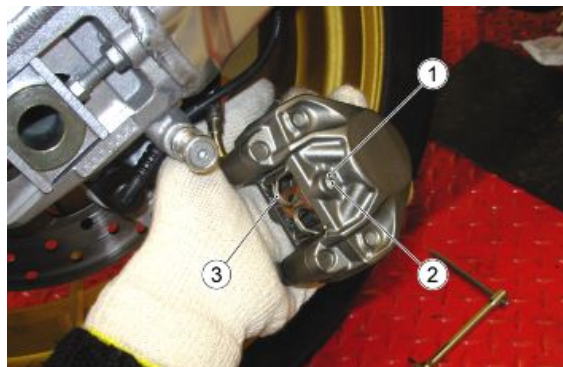
CAUTION



ALWAYS REPLACE BOTH PADS AND MAKE SURE THEY ARE CORRECTLY POSITIONED INSIDE THE CALLIPER.



- Place the safety spring (3).
- Hold the centre of the safety spring (3) depressed and insert the pin (2) so it passes above the spring.
- Fit the retainer ring (1).
- Check the brake fluid.



Bleeding the braking system

Front

Any air trapped in the hydraulic circuit acts as a cushion, absorbing much of the pressure applied by the brake pump and minimising the braking power of the calliper.

The presence of air is signalled by the "sponginess" of the brake control and by poor braking efficiency.

CAUTION

CONSIDERING THE DANGER FOR VEHICLE AND RIDER, IT IS STRICTLY NECESSARY, AFTER REFITTING BRAKES AND RESTORING THE BRAKING SYSTEM TO THE REGULAR USE CONDITIONS, THAT THE HYDRAULIC CIRCUIT BE AIR PURGED.

NOTE

THE FOLLOWING OPERATIONS REFER TO ONLY ONE FRONT BRAKE CALLIPER BUT APPLY TO BOTH CALLIPERS. THE VEHICLE MUST BE ON LEVEL GROUND TO BE PURGED. WHILE PURGING THE HYDRAULIC SYSTEM, FILL THE RESERVOIR WITH THE NECESSARY QUANTITY OF BRAKE FLUID. CHECK THAT, DURING THE OPERATION, THERE IS ALWAYS BRAKE FLUID IN THE RESERVOIR.

- Remove the rubber protection cover from the bleed valve.
 - Insert the transparent plastic pipe in the front brake calliper bleed valve and slide the other end of this pipe in a container to collect the fluid.
 - Remove the front brake oil reservoir cap.
 - Operate the brake lever and then open the bleed valve on the calliper 1/4 of a turn to let the air out.
 - Close the bleed again before reaching the lever end of the stroke and repeat the operation until there is no air.
 - Repeat the procedure for both callipers.
-
- Screw the bleeding valve and remove the pipe.
 - Top-up the reservoir until the correct brake fluid level is obtained.
 - Refit and block the front brake oil reservoir cap.
 - Refit the rubber protection cover.



Rear

Any air trapped in the hydraulic circuit acts as a cushion, absorbing much of the pressure applied by the brake pump and minimising the braking power of the calliper.

The presence of air is signalled by the "sponginess" of the brake control and by poor braking efficiency.

CAUTION

CONSIDERING THE DANGER FOR VEHICLE AND RIDER, IT IS STRICTLY NECESSARY, AFTER REFITTING BRAKES AND RESTORING THE BRAKING SYSTEM TO THE REGULAR USE CONDITIONS, THAT THE HYDRAULIC CIRCUIT BE AIR PURGED.

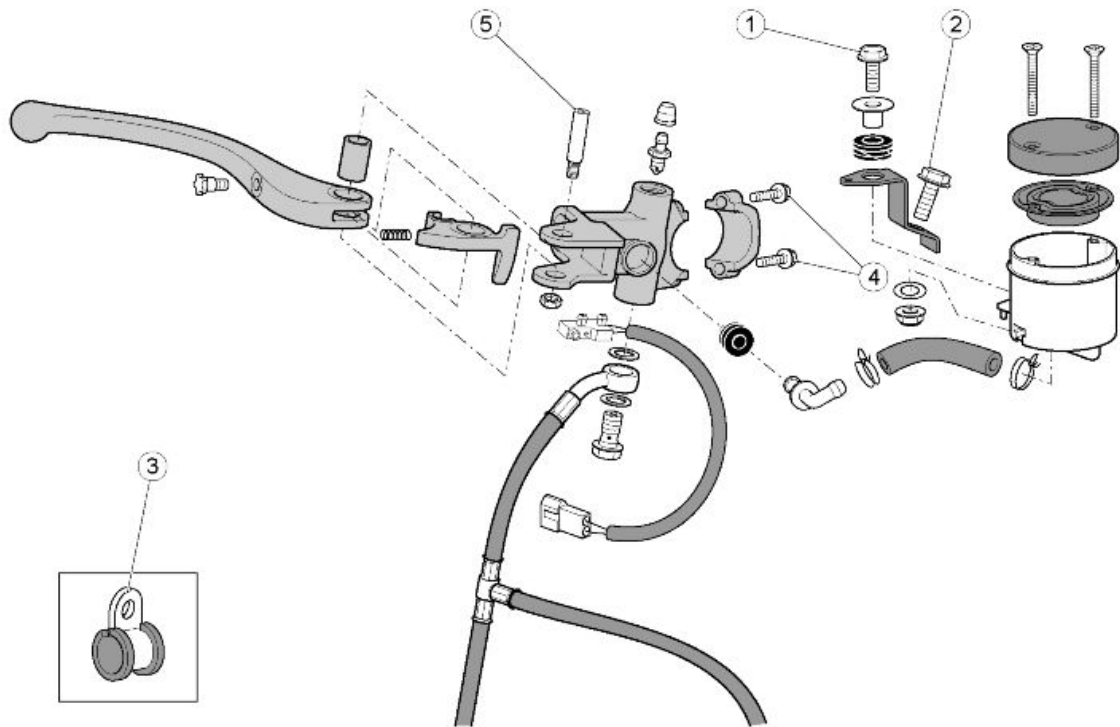
NOTE

THE VEHICLE MUST BE ON LEVEL GROUND TO BE PURGED. WHILE PURGING THE HYDRAULIC SYSTEM, FILL THE RESERVOIR WITH THE NECESSARY QUANTITY OF BRAKE FLUID. CHECK THAT, DURING THE OPERATION, THERE IS ALWAYS BRAKE FLUID IN THE RESERVOIR.

- Remove the rubber protection cover from the bleed valve.
- Insert the transparent plastic pipe in the rear brake calliper bleed valve and insert the other end of this pipe into a container to collect the fluid.
- Remove the rear brake oil reservoir cap.
- Operate the brake lever and then open the bleed valve on the calliper 1/4 of a turn to let the air out.
- Close the bleed again before reaching the lever end of the stroke and repeat the operation until there is no air.
- Screw the bleeding valve and remove the pipe.
- Top-up the reservoir until the correct brake fluid level is obtained.
- Refit and lock the rear brake oil reservoir cap.
- Refit the rubber protection cover.



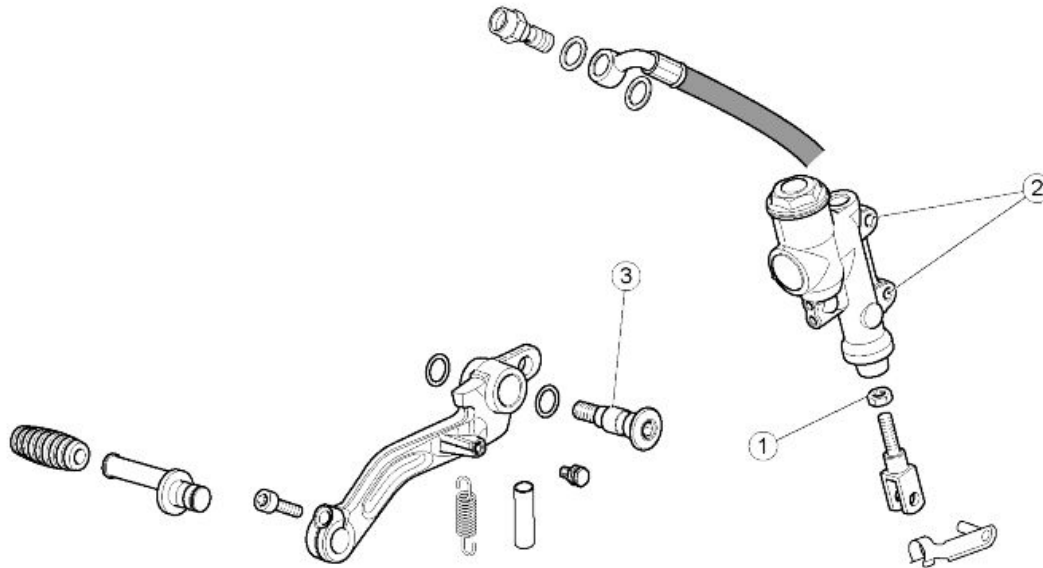
Front brake pump



FRONT BRAKE PUMP

pos.	Description	Type	Quantity	Torque	Notes
1	Screw fastening front brake fluid reservoir to bracket	M6	1	7 Nm (5.16 lbf ft)	-
2	Screw fastening brake fluid reservoir mounting bracket to handlebar	M6	1	7 Nm (5.16 lbf ft)	-
3	Screw fastening brake pipe grommet to the lower yoke	M5	1	8 Nm (5.9 lbf ft)	-
4	Front brake pump U bolt clamp	M6	2	10 Nm (7.37 lbf ft)	-
5	Front brake lever pin fixing screw	M6	1	10 Nm (7.37 lbf ft)	-

Rear brake pump

**REAR BRAKE PUMP**

pos.	Description	Type	Quantity	Torque	Notes
1	Rear brake rod lock nut	M6	1	12 Nm (8.85 lbf ft)	-
2	Rear brake pump fixing screws	M6	2	8 Nm (5.9 lbf ft)	-
3	Rear brake lever fixing screw	M8	1	25 Nm (18.44 lbf ft)	-

INDEX OF TOPICS

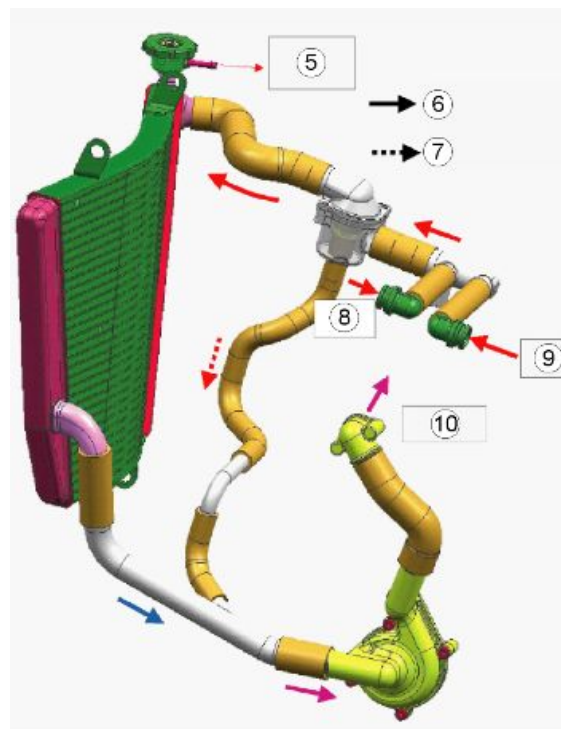
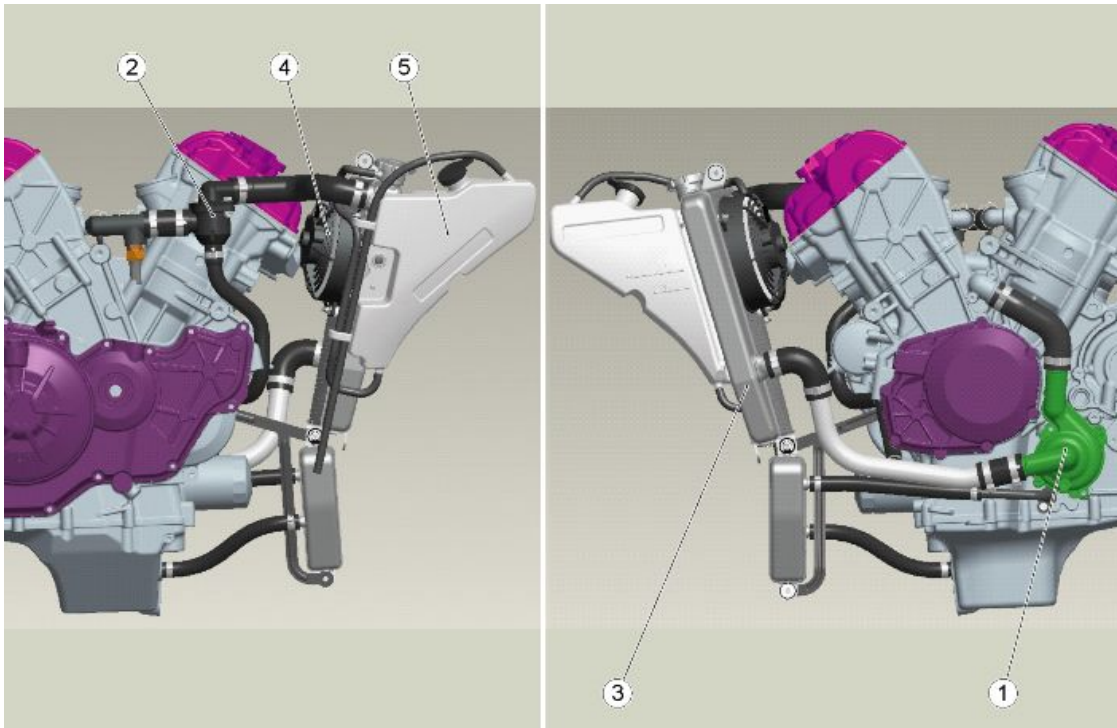
COOLING SYSTEM

COOL SYS

Circuit diagram

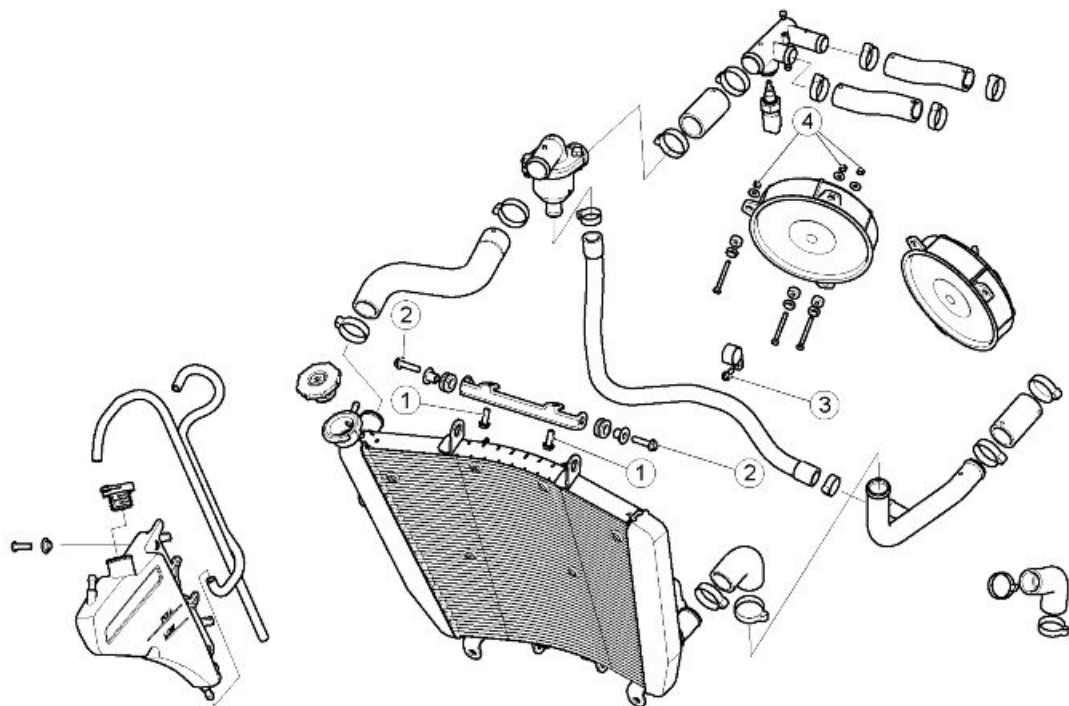
SYSTEM TYPE

Self bleeding cooling circuit with aspirating centrifugal pump (1), three-way thermostat valve (2), cooling radiator (3) with electric fans (4) and expansion tank (5).



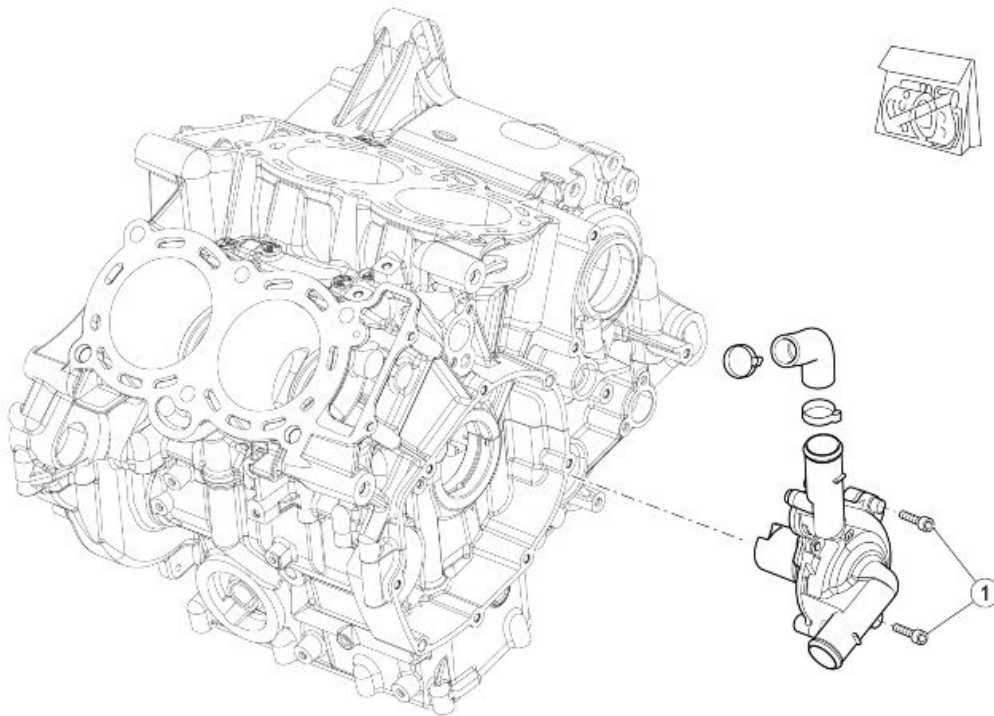
key:

1. Centrifugal pump
2. Thermostatic valve
3. Radiator
4. Electric fans
5. Expansion tank
6. With the thermostat open
7. With the thermostat closed
8. From front head
9. From rear head
10. To upper crankcase



COOLING

pos.	Description	Type	Quantity	Torque	Notes
1	Screws fastening water radiator mounting bracket to chassis	M6	2	10 Nm (7.37 lbf ft)	-
2	Screws fastening water radiator to mounting bracket	M6	2	7 Nm (5.16 lbf ft)	-
3	Screw fastening pipe grommet for By-pass water hose	M5	1	6 Nm (4.42 lbf ft)	-
4	Screws fastening electric fan to water radiator	M4	6	2 Nm (1.47 lbf ft)	-

**WATER PUMP**

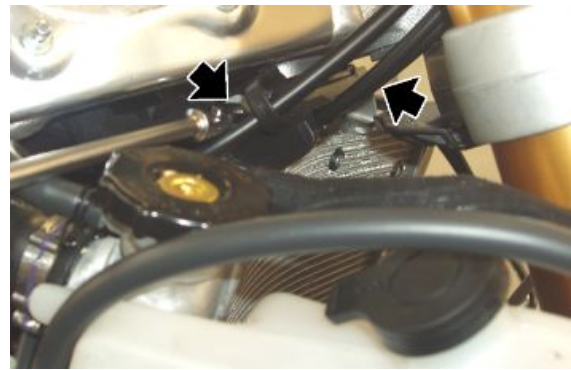
pos.	Description	Type	Quantity	Torque	Notes
1	Screws fastening the pump to the crankcase	M6x25	2	10 Nm (7.37 lbf ft)	-

Electric fan**ELECTRIC FAN REMOVAL (OPT.1)**

- Remove the front underfairings and the hand grip position sensor
- Disconnect the cooling fan connector to be replaced.



- Unscrew and remove both radiator upper fixing screws.



See also

[Fairing mounting panels](#)
[Twistgrip position sensor](#)

- Move the radiator forward.
- Unscrew and remove the three fan retainers and retrieve the washers.



ELECTRIC FAN REMOVAL (OPT.2)

- Remove the front underfairings and the hand grip position sensor
- Disconnect the cooling fan connector to be replaced.



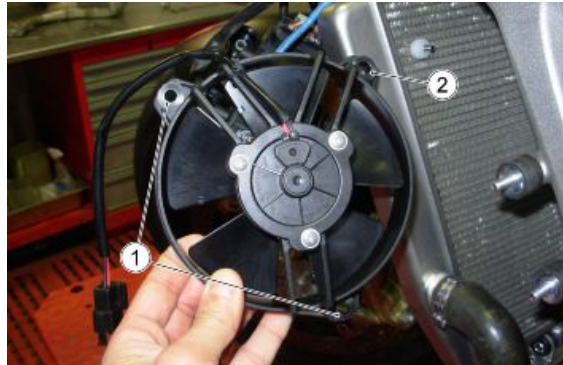
- Internally blocking the nuts, unscrew the fixing screw from the internal part.
- Make sure that the nuts and washers are retrieved.



See also

[Fairing mounting panels](#)
[Twistgrip position sensor](#)

- The retainer points of the electric fan are not the same as the hole (2), compared to the holes (1), has a different thickness and is therefore fixed from the internal side using a threaded "T" bushing.



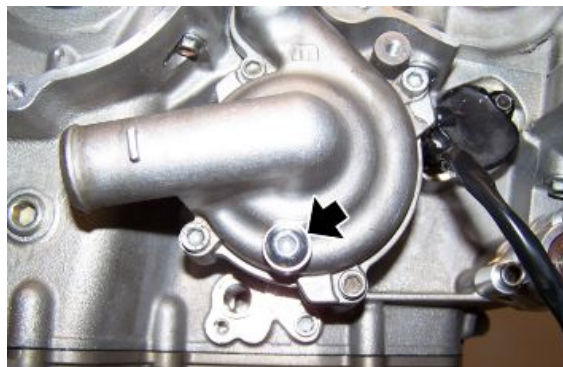
- Now it is possible to remove the electric fan.

Coolant replacement

- Remove both fairings.
- Place a container with a suitable capacity under the coolant pump.
- Remove the radiator cap/valve to help the fluid drain out.



- Unscrew and remove the system drain screw and retrieve the sealing washer.
- Wait for the entire circuit to drain (engine+pipes+radiator)
- Refit the system drain screw complete with a new washer.

**FILLING**

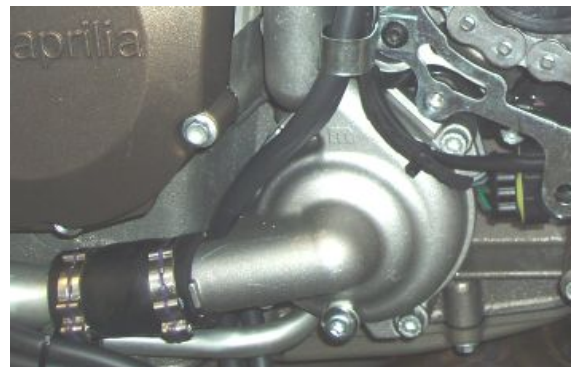
- Via the filler orifice on the radiator, fill with the quantity of coolant (approx. 2.2 l - 0.48 UK gal) necessary to reach the edge.
- Fit the cap / valve.

- Via the filler orifice on the expansion tank, fill with the quantity of coolant necessary to reach the FULL marking, then refit the cap.
- Start the engine, run at idle speed and wait for the electric fans to activate (approx. 101 °C - 213 °F) then turn off the engine and wait for it to cool.
- With the vehicle standing vertically, check the liquid level both in the radiator and in the expansion tank and top up if necessary.

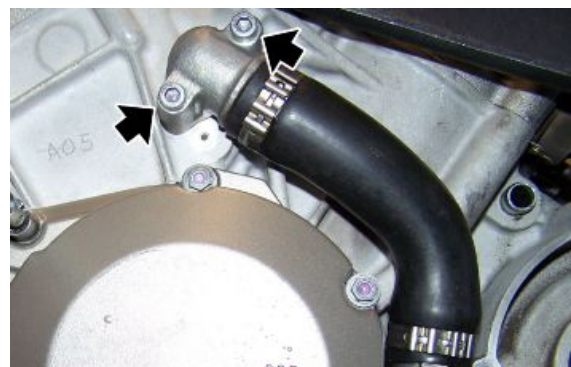


Water pump

- Drain the coolant.
- Remove the pipe from the radiator.



- Unscrew and remove the two screws fastening the pipe to the engine.
- Retrieve the gasket and replace with a new component when refitting.



See also

Coolant replacement

- Unscrew and remove the two screws fastening the pump to the engine.
- Remove the coolant pump.



- Unscrew and remove the two external pump cover fixing screws.



- Unscrew and remove the inner screw.
- Remove the pump cover.



TO PREVENT IRREPARABLE DAMAGE TO THE PUMP, UNSCREW AND REMOVE THE INNER SCREW BEFORE REMOVING THE COVER.



- At each removal, replace the inner gasket between the pump casing and the cover and the O ring on the pump casing.

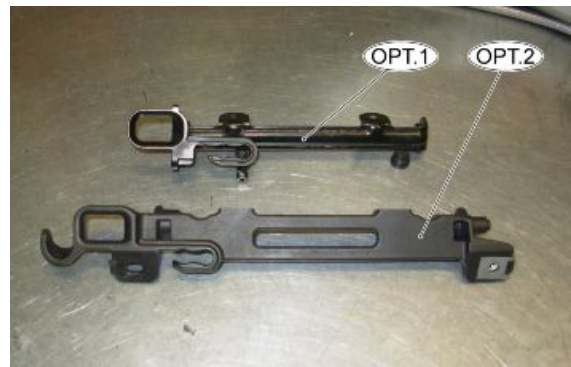
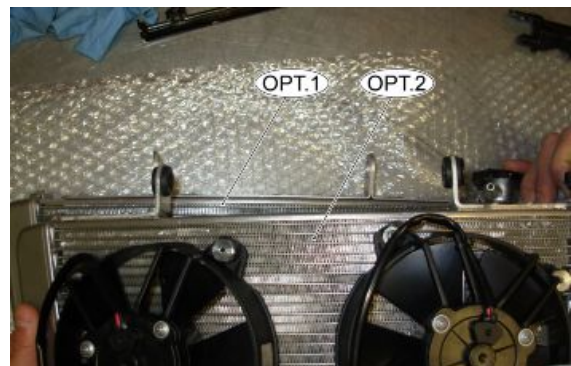


ENSURE THAT THE LIQUID PASSAGE ORIFICES ARE NOT OBSTRUCTED.



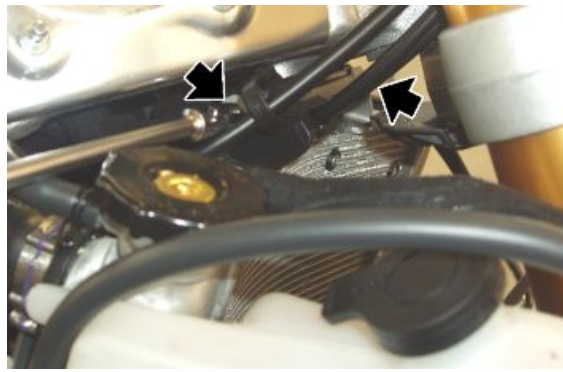
Removing the radiator

Following the optimization of the product, there may be two types of radiators with corresponding electric fans and retainer brackets.



RADIATOR BRACKET REMOVAL (OPT.1)

- Unscrew and remove both radiator upper fixing screws.



- Remove the two chassis bracket fixing screws.
- Then remove the radiator retainer bracket.



RADIATOR BRACKET REMOVAL (OPT.2)

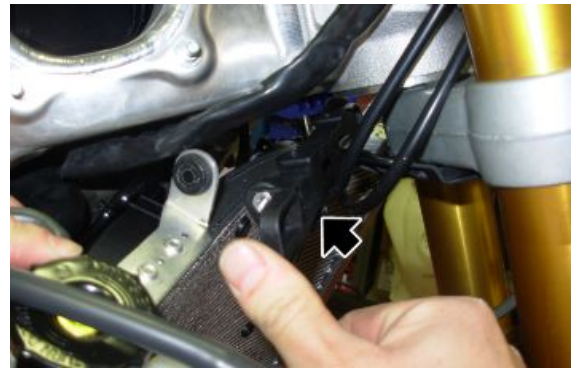
- Operating from the right side of the motorcycle, move the main cable harness and remove the screw fixing the radiator to the retainer bracket.



- Remove the two chassis bracket fixing screws.
- Then remove the radiator retainer bracket.



- Moving the bracket outwards, it is then possible to remove it by sliding it out.

**CAUTION**

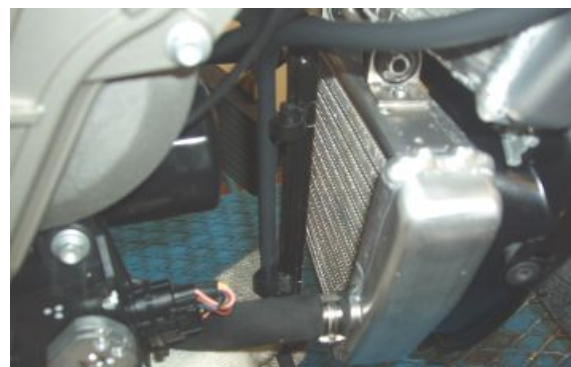
DURING THE REFIT PHASE, MAKE SURE THAT THE MAIN CABLE HARNESS IS CORRECTLY POSITIONED ON THE CAVITY OF THE RADIATOR RETAINER BRACKET, IN ORDER TO PREVENT THE CABLE HARNESS FROM COMING INTO CONTACT WITH THE RADIATOR AT HIGH TEMPERATURE AND DAMAGING ITSELF.

RADIATOR REMOVAL

- Drain off the cooling system.
- Remove the front underfairings and the hand grip position sensor
- Disconnect both cooling fan connectors.

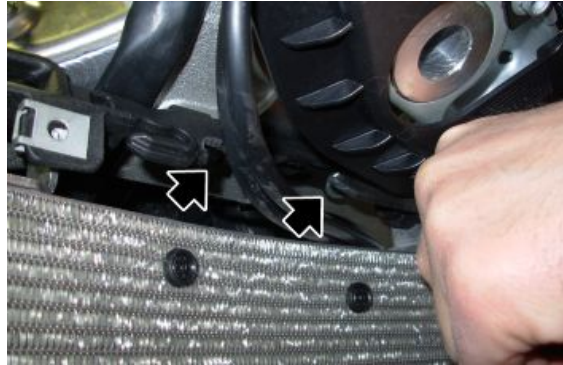


- Disconnect the expansion tank breather pipe from the pipe grommet.

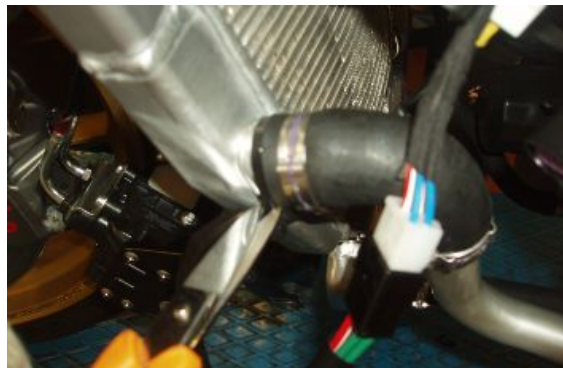
**See also**

Coolant replacement
[Fairing mounting panels](#)
[Twistgrip position sensor](#)

- Remove the two fixing screws of the radiator bracket.



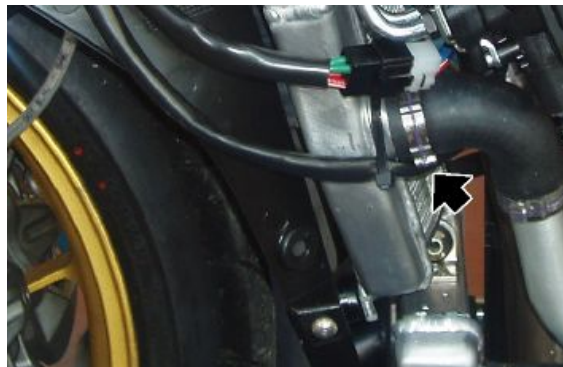
- Cut the clamp fastening the cable harness to the radiator return pipe on the left hand side.



- Release the clamp fastening the return pipe to the radiator pipe



UPON REFITTING, REPLACE CLIC CLAMP REMOVED WITH A NEW ONE OF EQUAL SIZE. DO NOT REFIT THE CLIP-ON CLAMP REMOVED PREVIOUSLY AS IT IS NO LONGER USABLE. DO NOT REPLACE THE CLIP-ON CLAMP REMOVED PREVIOUSLY WITH A SCREW CLAMP OR ANY OTHER TYPE OF CLAMP.



- Release the clamp fastening the delivery pipe to the radiator pipe



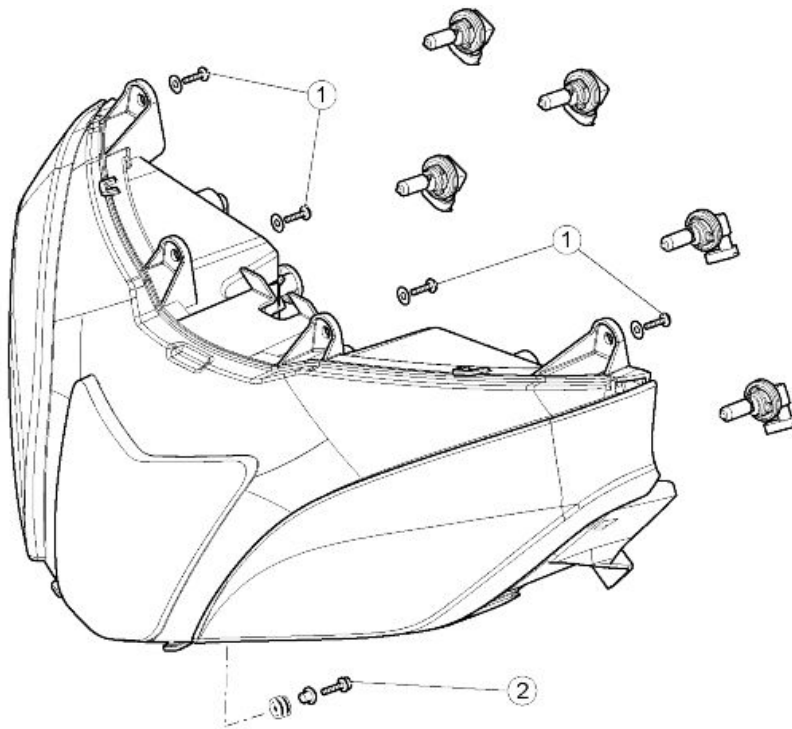
UPON REFITTING, REPLACE CLIC CLAMP REMOVED WITH A NEW ONE OF EQUAL SIZE. DO NOT REFIT THE CLIP-ON CLAMP REMOVED PREVIOUSLY AS IT IS NO LONGER USABLE. DO NOT REPLACE THE CLIP-ON CLAMP REMOVED PREVIOUSLY WITH A SCREW CLAMP OR ANY OTHER TYPE OF CLAMP.



INDEX OF TOPICS

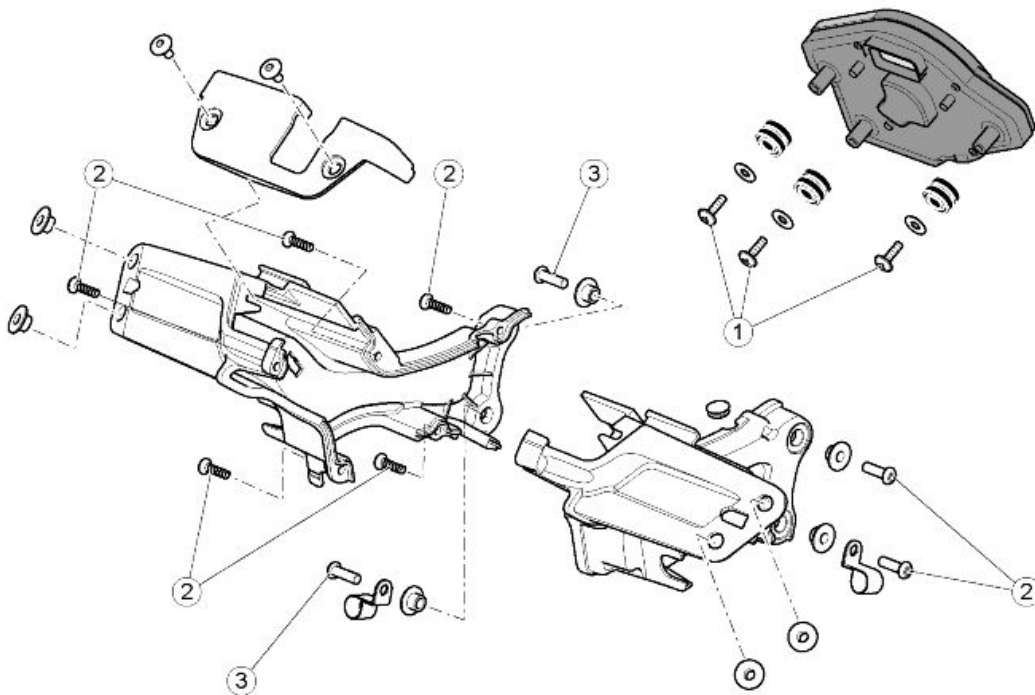
BODYWORK

BODYW



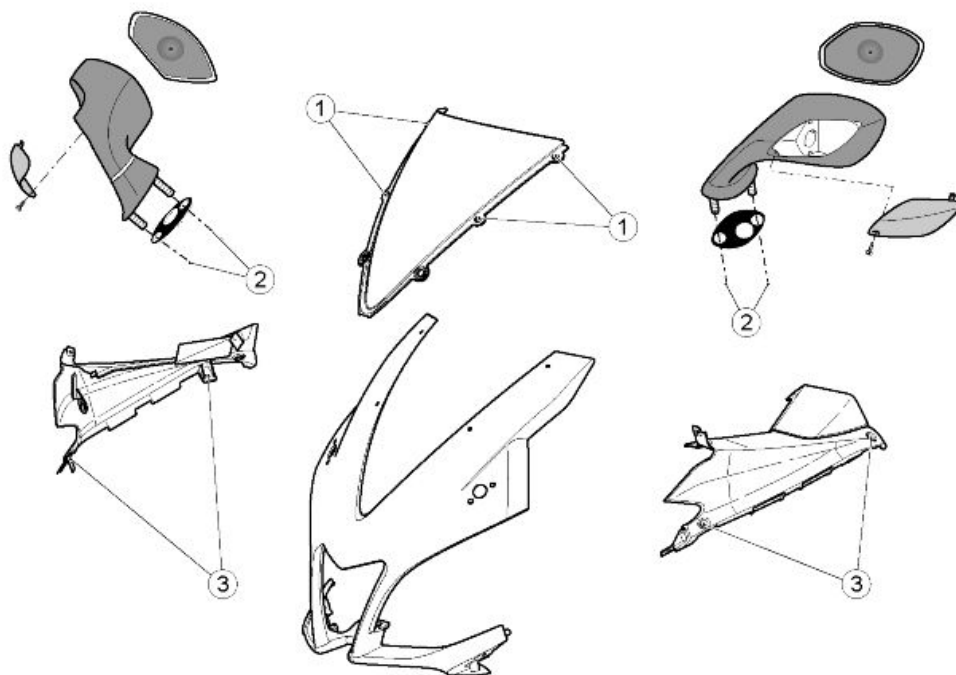
HEADLAMP

pos.	Description	Type	Quantity	Torque	Notes
1	Screw fastening headlamp to front fairing	SWP 4.9	4	2 Nm (1.47 lbf ft)	-
2	Headlamp fixing screw	M5	2 + 1	2 Nm (1.47 lbf ft)	-



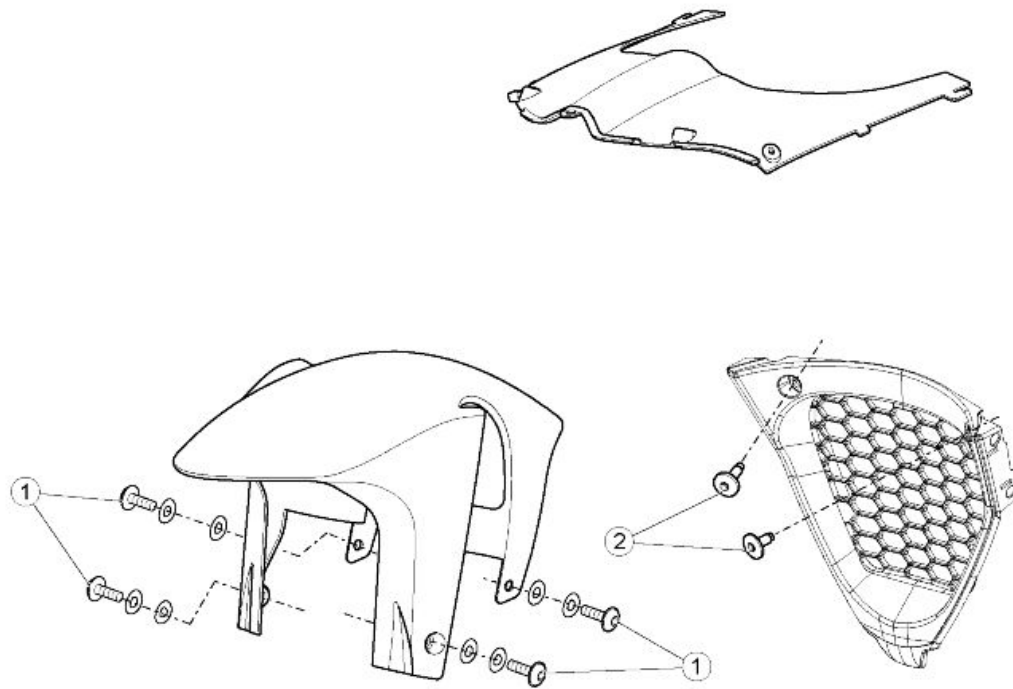
INSTRUMENT PANEL

pos.	Description	Type	Quantity	Torque	Notes
1	Screws fastening the rubber rings to the instrument panel	SWP 4.9	3	3 Nm (2.21 lbf ft)	-
2	Instrument panel mounting shell fixing screws	SWP 4.9	5	2 Nm (1.47 lbf ft)	-
3	Screws fastening instrument panel mounting to chassis	M6	4	8 Nm (5.9 lbf ft)	-



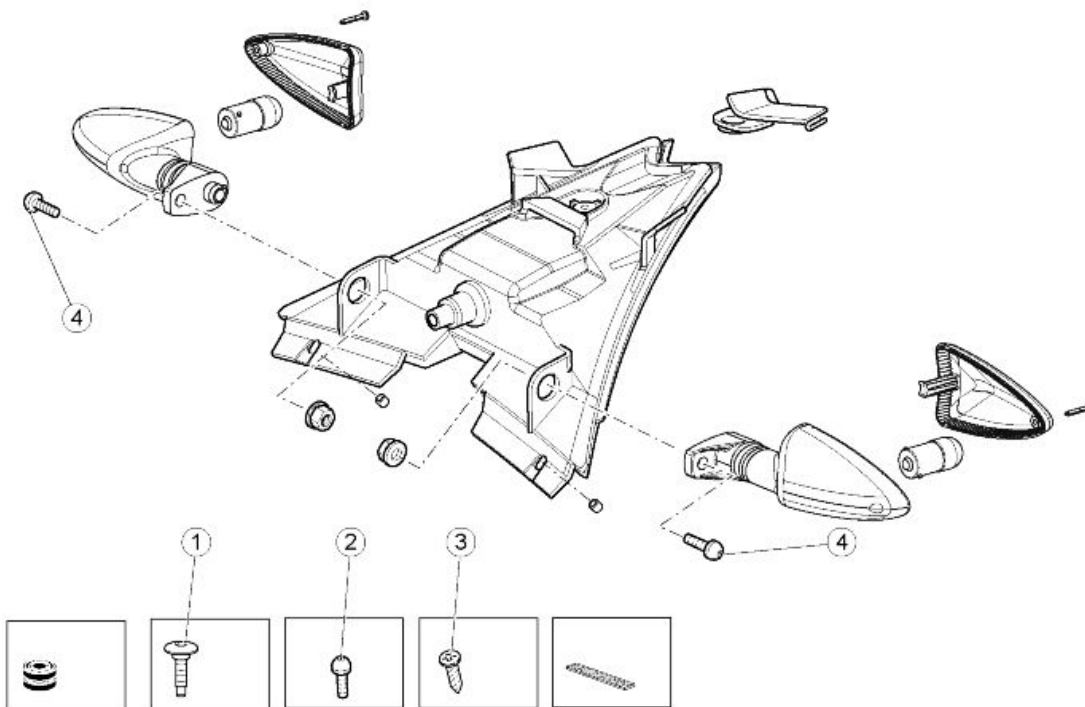
WINDSHIELD

pos.	Description	Type	Quantity	Torque	Notes
1	Windshield fixing screws	M4	4	0.5 Nm (0.37 lbf ft)	-
2	Rear-view mirror fixing nuts	M6	2 + 2	10 Nm (7.37 lbf ft)	-
3	- Screws fastening the side fairings to front fairing	M5	4	1 Nm (0.74 lbf ft)	-



FRONT MUDGUARD

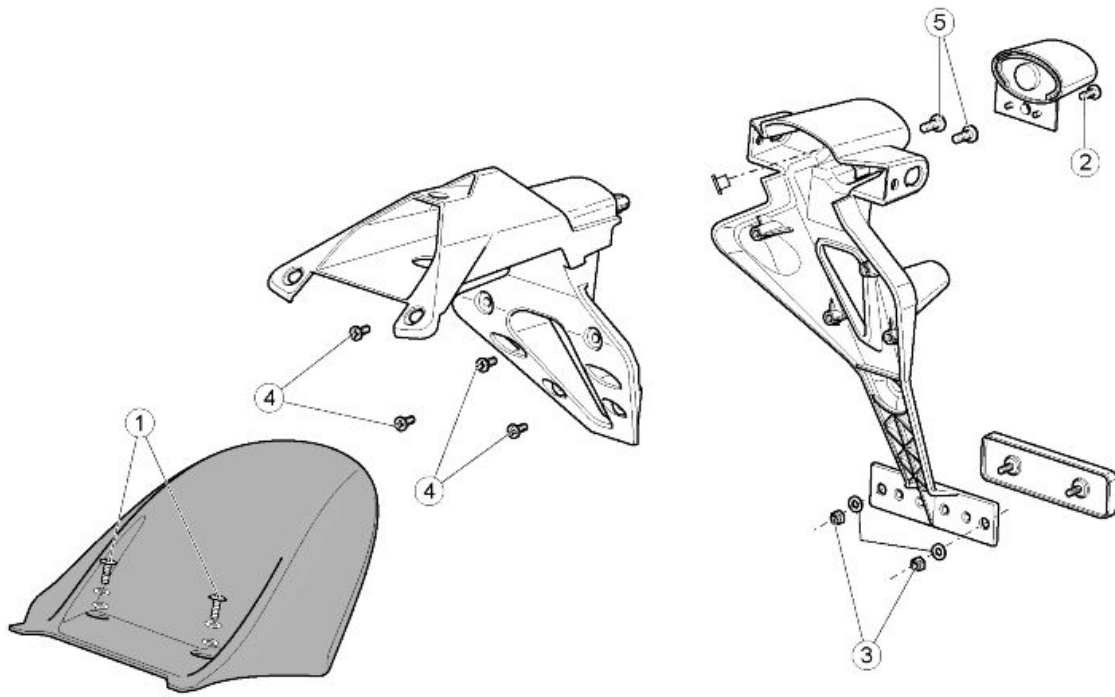
pos.	Description	Type	Quantity	Torque	Notes
1	Front mudguard fixing screws	M5	4	3 Nm (2.21 lbf ft)	-
2	Lug fixing screws	M5	2	4 Nm (2.95 lbf ft)	-



TAILLIGHT

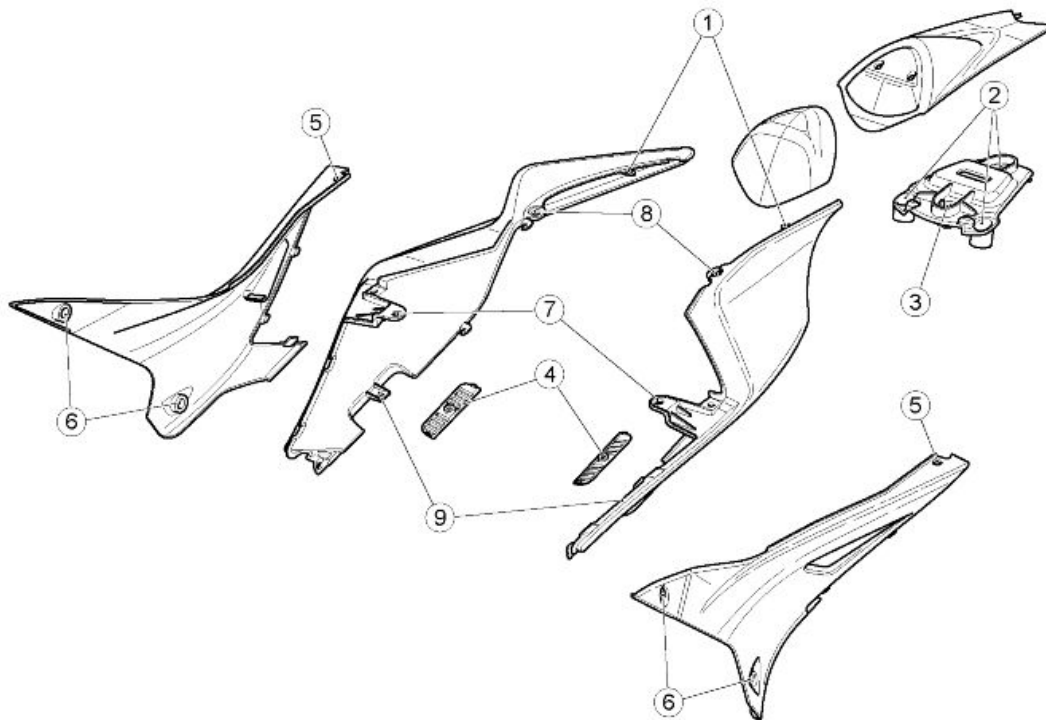
pos.	Description	Type	Quantity	Torque	Notes
1	Taillight fixing screws	M5	2	3 Nm (2.21 lbf ft)	-

pos.	Description	Type	Quantity	Torque	Notes
2	Taillight mounting bracket fixing screws	M5	2	4 Nm (2.95 lbf ft)	-
3	Rear turn indicator fixing screws	M6	2	2.5 Nm (1.84 lbf ft)	-
4	Taillight cover fixing screws	SWP 2.9	1	0.5 Nm (0.37 lbf ft)	-



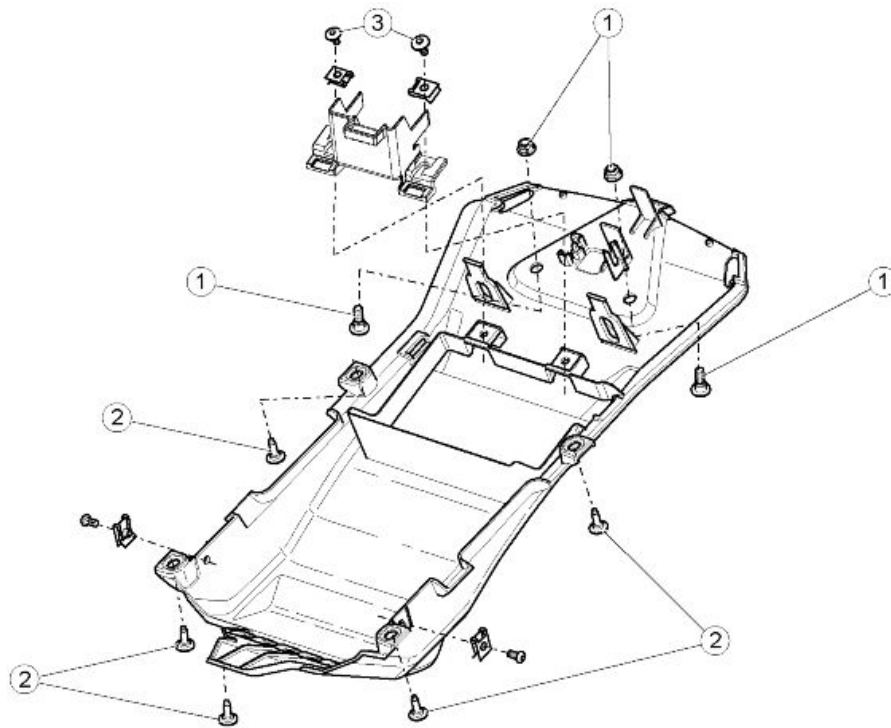
LICENSE PLATE HOLDER

pos.	Description	Type	Quantity	Torque	Notes
1	Rear mudguard fixing screws	M6	2	3 Nm (2.21 lbf ft)	-
2	License plate light fixing screws	M4	1	1 Nm (0.74 lbf ft)	-
3	Reflector fixing nuts	M4	2	1 Nm (0.74 lbf ft)	-
4	Screws fastening rear license plate holder to front license plate holder	SWP 3.9	4	1 Nm (0.74 lbf ft)	-
5	Screws fastening rear license plate holder to front license plate holder	SWP 4.9	2	2 Nm (1.47 lbf ft)	-
-	Screws fastening license plate mounting to saddle mounting casting	M6	3	4 Nm (2.95 lbf ft)	-



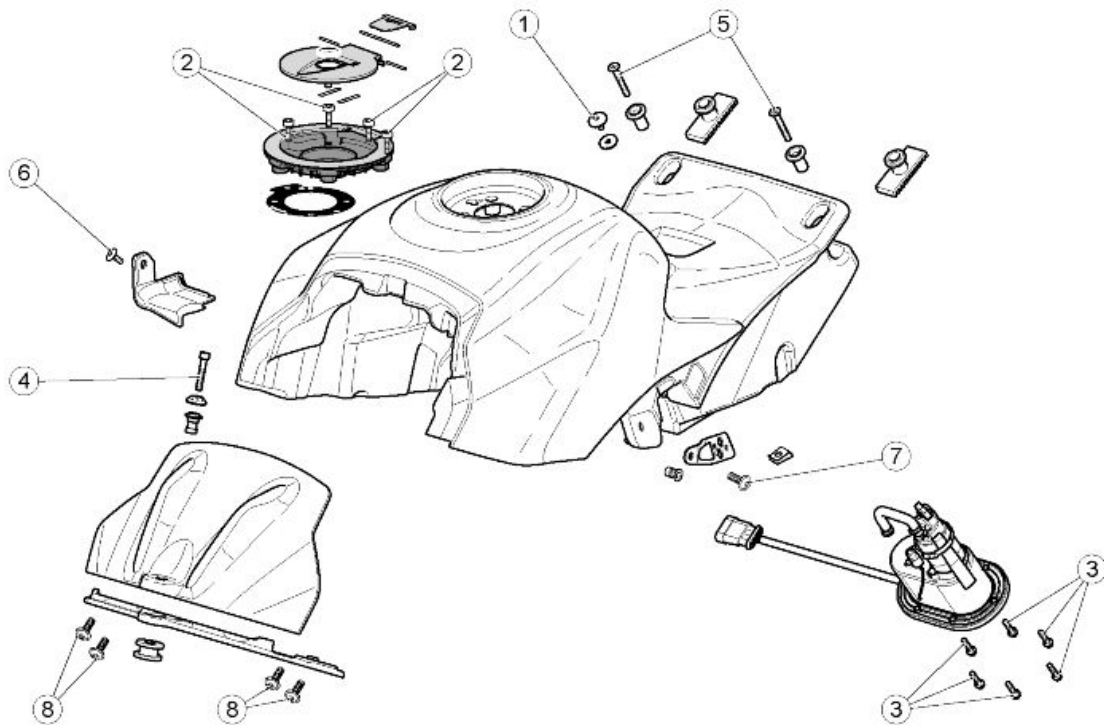
TAIL FAIRING

pos.	Description	Type	Quantity	Torque	Notes
1	Rear screws fastening tail fairing to taillight bracket	M5	2	3 Nm (2.21 lbf ft)	-
2	Screws fastening the saddle cover base to the saddle cover	SWP 2.9	3	1 Nm (0.74 lbf ft)	-
3	Saddle cover pin fixing screws	M4	1	1.5 Nm (1.11 lbf ft)	-
4	Screws fastening grilles to tail fairing	M5	2	0.5 Nm (0.37 lbf ft)	-
5	Screws fastening side fairings to tail fairing	M5	2	1 Nm (0.74 lbf ft)	-
6	Screws fixing side fairings to tank	M5	2 + 2	2 Nm (1.47 lbf ft)	-
7	Screws fastening tail fairing to saddle mounting	M5	2	3 Nm (2.21 lbf ft)	-
8	Screws fastening tail fairing to saddle mounting bracket	M5	2	2 Nm (1.47 lbf ft)	-
9	Screws fixing tail fairing to lower saddle mounting fastener	M5	2	3 Nm (2.21 lbf ft)	-



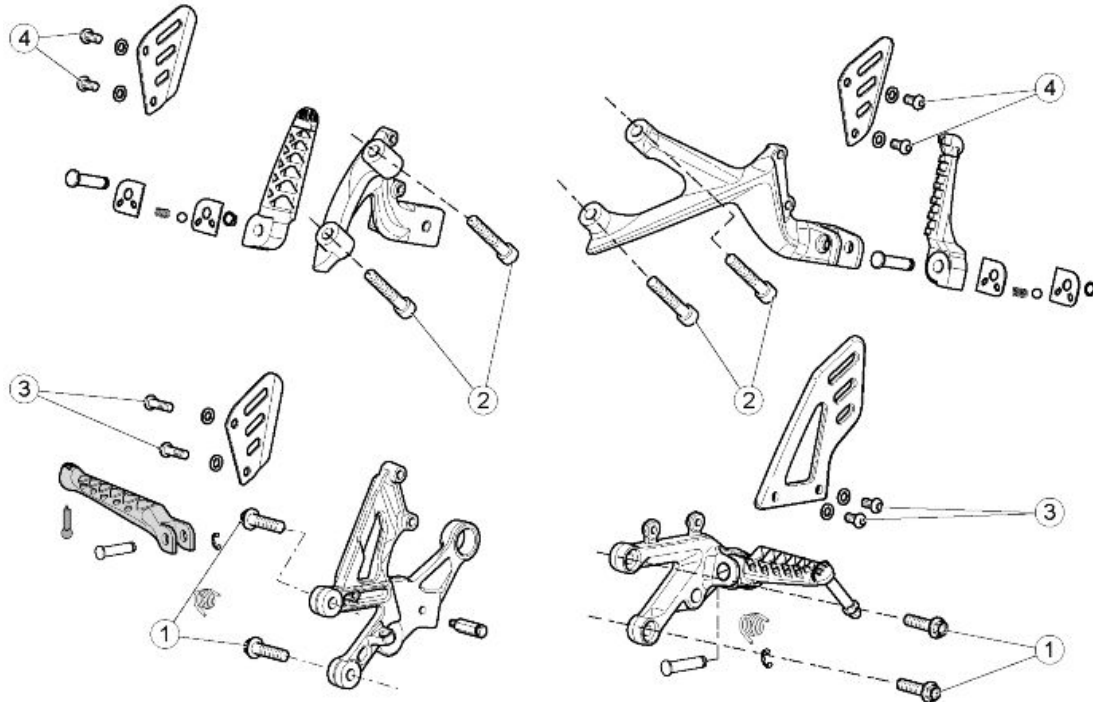
HELMET COMPARTMENT

pos.	Description	Type	Quantity	Torque	Notes
1	Screws and nuts for fastening license plate holder to saddle mounting plate	M6	2	4 Nm (2.95 lbf ft)	-
2	Lower saddle mounting fastener fixing screws	M5	5	3 Nm (2.21 lbf ft)	-
3	Battery bracket fixing screws	M5	2	2 Nm (1.47 lbf ft)	-



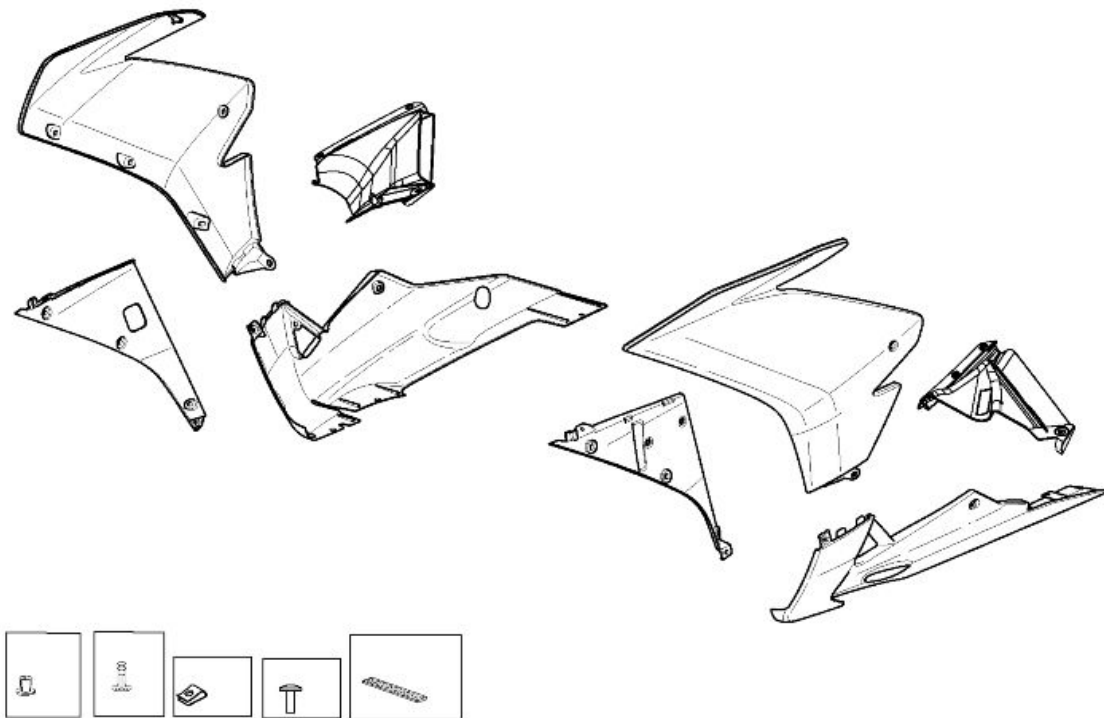
FUEL TANK

pos.	Description	Type	Quantity	Torque	Notes
1	Special screw fastening rider saddle to the tank	M6	1	4 Nm (2.95 lbf ft)	-
2	Screws fixing the filler to the tank	M5	4	4 Nm (2.95 lbf ft)	-
3	Screws fixing the fuel pump flange to the tank	M5	8	3 Nm (2.21 lbf ft)	-
4	Front screws fastening the tank to the chassis	M6	1	8 Nm (5.9 lbf ft)	-
5	Rear screws fastening the tank to the rear chassis	M6	2	7 Nm (5.16 lbf ft)	-
6	Screws fastening plastic fuel pipe mounting	M5	1	2.5 Nm (1.84 lbf ft)	-
7	Left fairing mounting bracket fixing screws	M5	1	3 Nm (2.21 lbf ft)	-
8	Screws fastening structural tank mounting to tank	M6	4	3 Nm (2.21 lbf ft)	-
-	Central screw fastening the cover to the tank	M4	1	0.5 Nm (0.37 lbf ft)	-
-	Fuel tank breather pipe unions	M7	2	3 Nm (2.21 lbf ft)	-



FOOTRESTS

pos.	Description	Type	Quantity	Torques	Notes
1	Screws fastening rider footpegs to chassis	M8	2 + 2	25 Nm (18.44 lbf ft)	-
2	Screws fastening passenger footpegs to chassis	M8	2 + 2	18 Nm (13.28 lbf ft)	For countries in which passenger footpegs are mandatory or for two seat configuration
3	Rider heelrest fixing screws	M6	2 + 2	8 Nm (5.9 lbf ft)	-
4	Passenger heelrest fixing screws	M6	2 + 2	8 Nm (5.9 lbf ft)	-
-	Anti-slip pin	M6	1	8 Nm (5.9 lbf ft)	-

**FAIRING**

pos.	Description	Type	Quantity	Torque	Notes
-	Centre screws fastening lower fairing	M6	2	10 Nm (7.37 lb ft)	-
-	Right hand lower fairing mounting bracket	M6	2	10 Nm (7.37 lb ft)	-
-	Left hand lower fairing mounting bracket	M6	2	10 Nm (7.37 lb ft)	-
-	Screws fixing the side fairings to the side spacers	M5	2	1.5 Nm (1.11 lb ft)	-
-	Screws fixing upper fairing fastener to intake duct	M5	2	1.5 Nm (1.11 lb ft)	-
-	Screws fixing upper fairing fastener to front fairing	M5	2	1.5 Nm (1.11 lb ft)	-
-	Screws fixing upper fairing fastener to intake duct	self-tapping	2	1 Nm (0.74 lb ft)	-
-	Screws fixing upper fairing fastener to headlamp	self-tapping	2	1 Nm (0.74 lb ft)	-
-	Screws fastening the lower fairing to the bracket	M5	2 + 2	1 Nm (0.74 lb ft)	-
-	Screws fastening the lower fairing to the lug	M5	2	2 Nm (1.47 lb ft)	-
-	Lower fairing lower fastening screws	M5	2	2 Nm (1.47 lb ft)	-
-	Lower fork fastener fixing screws	M6	2	8 Nm (5.90 lb ft)	-
-	Screws fixing lower front fairing fastener to intake ducts	SWP 3.9	2	1 Nm (0.74 lb ft)	-
-	Inner screws fixing fairing to the lower front fairing fastener	M4	2	0.5 Nm (0.37 lb ft)	-
-	Inner screws fastening the fairing to the lug	M5	2	2 Nm (1.47 lb ft)	-

Driving mirrors

- The following procedure is for a single rear view mirror, but is applicable to both mirrors.
- Unscrew and remove the two nuts, supporting the rear view mirror.



-
- Disconnect the turn indicator connector from the relative fixed connector on the instrument panel.



- Guiding the turn indicator cable through the relative hole on the windshield, remove the rear view mirror.
-

Instrument panel

- Remove the windshield.
- Unscrew and remove the two screws.



- Remove the instrument panel mounting cover.
- Move the instrument panel, removing the rubber rings from the seats on the support.



- Rotate the instrument panel connector retainer lever.
- Remove the connector.
- Remove the instrument panel.

NOTE

WHEN REFITTING THE CONNECTORS, THE SLIDES MUST MOVE FREELY TO THE END OF STROKE, WHICH HELPS WITH THE INSERTION OF THE CONNECTOR: YOU MUST HEAR THE RELEASE OF THE RETAINING TANG AT THE END OF STROKE.



Headlight fairing

- Remove the side fairings.
- Disconnect the turn indicator connectors from the fixed connector on the instrument panel mounting.
- Remove the two rear view mirrors if necessary.
- Remove the three lower inserts.

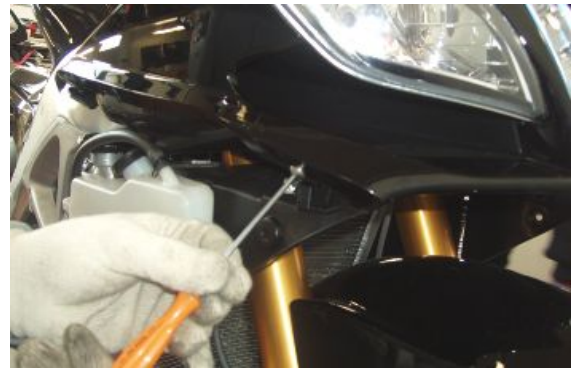


See also

Side fairings

- Working from both sides, unscrew and remove the four screws.





- Supporting the windshield, move it forward to create the minimum space necessary to work on the front bulb connectors.
- Disconnect the front bulb connectors.



- Remove the windshield in a forward motion.



Side fairings

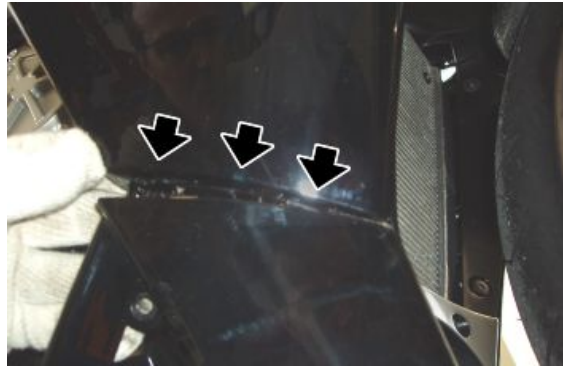
SIDE FAIRINGS

The following procedure is relative to a single fairing, but is applicable to both.

- Remove the lower side fairing.
- Unscrew and remove the three screws.



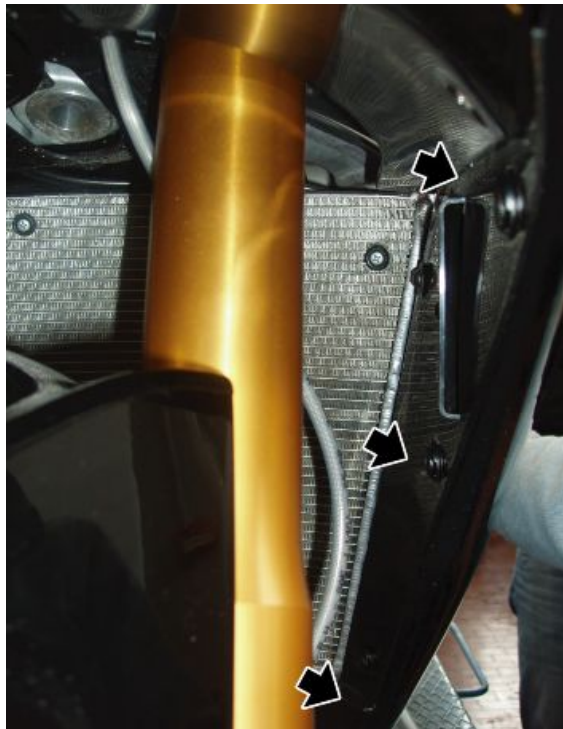
- Ease off the side fairing, taking particular care not to damage the fitting with the lower side fairing and the tabs fastening the side fairing to the lug.



- Release the insert on the retainer with the duct.



- Release the three inserts on the inner fairing.



- To refit, repeat the above procedure in reverse order, taking particular care not to damage the components involved.

NOTE

HANDLE PAINTED AND PLASTIC COMPONENTS WITH CARE; BE CAREFUL NOT TO SCRATCH OR DAMAGE THEM.

LOWER SIDE FAIRINGS

- The operations described below are valid for both lower side fairings.
- Remove the side fairing.
- Unscrew and remove the screw and remove the lower side fairing.

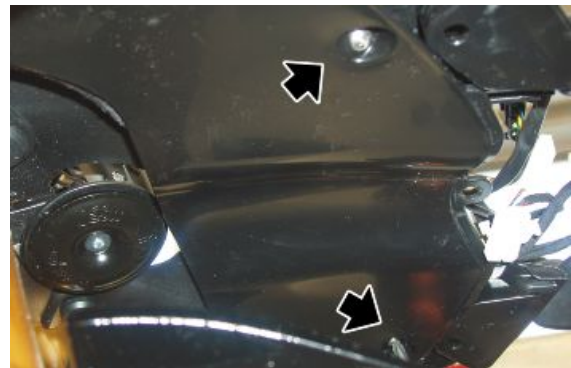


Fairing mounting panels**CENTRAL UNDERFAIRING**

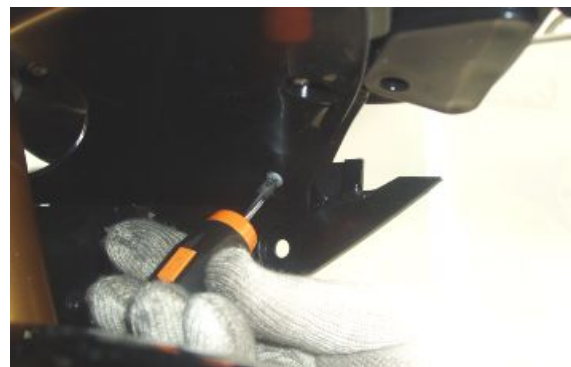
- Remove the three windshield fixing inserts.



- Unscrew and remove the two screws.
- Ease off the central underfairing, taking care not to damage the fittings with the lateral underfairings and the windshield.

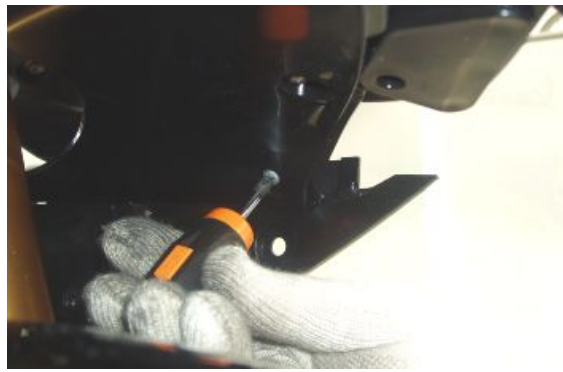


- Working from both sides, unscrew and remove the lower screw.



LATERAL UNDERFAIRINGS

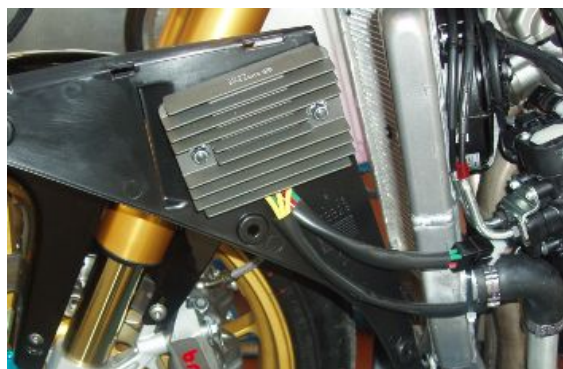
- The following procedure is relative to a single lateral underfairing, but is applicable to both, except where specified otherwise.
- Unscrew and remove the central underfairing fixing screw.



-
- Remove the respective side fairing.
 - Unscrew and remove the lower screw.



-
- When working on the left hand side of the vehicle, remove the underfairing taking particular care not to damage the fittings with the central underfairing.
 - When working on the left hand side of the vehicle, support the left hand underfairing, unscrew and remove the two nuts, retrieve the screws and lower the regulator.
 - Remove the underfairing.



Air box

FILTER BOX COVER REMOVAL

- Remove the control unit.
- Disconnect the air temperature sensor connector.



-
- Move the two rear coil connectors



See also

[Control unit](#)

-
- Unscrew and remove the four upper injector screws.
 - Move the upper injector mounting.



-
- Disconnect the variable geometry intake system connector. (if connected)



- Unscrew and remove the eight air filter box cover screws.
- Remove the air filter box cover.



FILTER BOX BASE

- Open the air filter box cover.
- Unscrew and remove the air intake duct fixing screws.



- Disconnect the variable geometry intake system connector. (If connected)

- Working from both sides, unscrew and remove the air pressure sensor fixing screw.



- Disconnect both front coil connectors (cylinders 2 and 4).



- Working from both sides, disconnect the Blow-by system intake pipes.



- Release the cable harness from the cable grommet on the filter box.
- Remove the air filter box base.



Rear mudguard

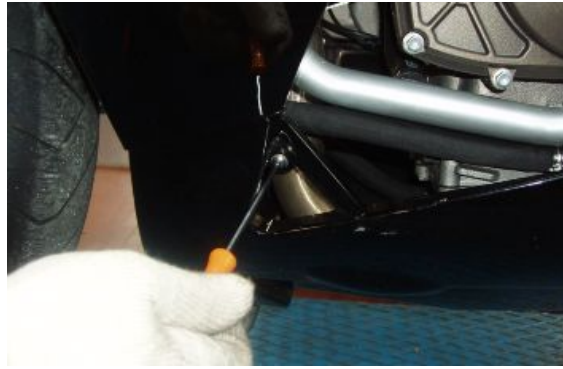
- Unscrew and remove the two screws.
- Remove the rear mudguard.



Lower cowl

- The following procedure is applicable to both parts of the fairing lug.
- Remove the lower side fairing.

- Unscrew and remove the front screw.



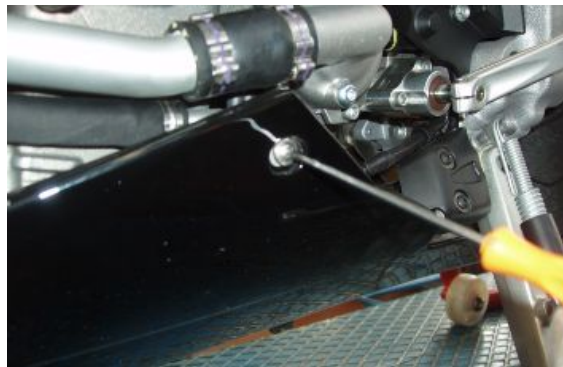
See also

Side fairings

- Unscrew and remove the lower screw.



- Supporting the right fairing lug, unscrew and remove the right lug fixing screw and remove the lug.
- Remove the left fairing lug in the same manner.



Fuel tank

- Unscrew and remove the front screw fixing the tank.



-
- Remove the rider saddle.
 - Unscrew and remove the two rear screws.



-
- Release the clamps.
 - Remove the two tank breather pipes.



-
- Disconnect the fuel pipe.



- Disconnect the fuel pump connector.
- Remove the tank.



Front mudguard

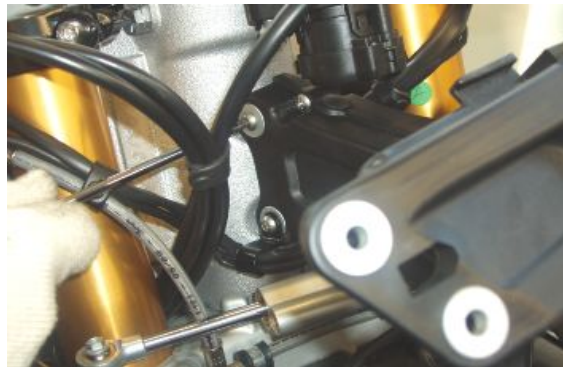
- Working from both sides, unscrew and remove the two screws.
- Remove the front mudguard.



Instrument cluster support

REMOVAL

- Remove the instrument panel.
 - Working on both sides, unscrew and remove the two screws fastening the arch brace to the headstock.
 - Retrieve the cable grommet.
-
- Unscrew and remove the five semi-arch brace fixing screws.



See also

Instrument panel

- Separate and remove the two semi-arch braces



FITTING

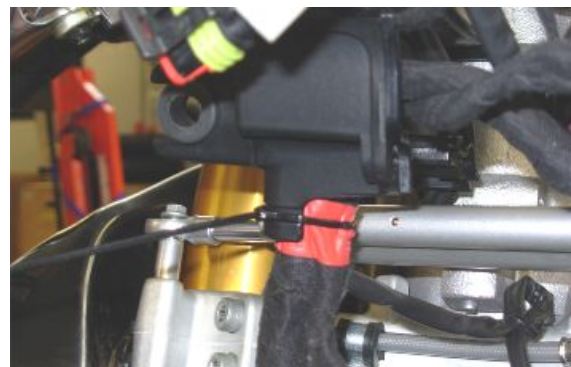
- Fit the right semi-arch brace, fixing it to the headstock with two screws.



-
- Connect the Immobilizer aerial cables.



- Fasten the main cable harness to the semi-arch brace with a clamp.



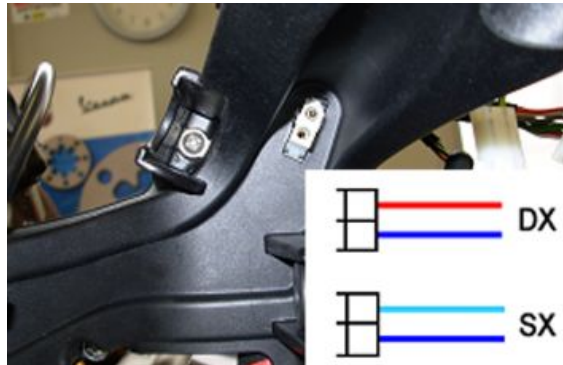
- Gather the cables on the right semi-arch brace and fasten them provisionally with a clamp.
- Fit the left semi-arch brace, applying the five coupling screws. Do not strain the connection between the two semi-arch braces, as this would prevent the removal of the clamp.



- Cut and remove the provisional clamp.
- Fit the cable grommet from the left hand side of the arch brace, tighten the two screws on the headstock.
- Tighten the five coupling screws.



- Fit the turn indicator connectors in the relative housings, noting the colours of the wires identifying the correct side.



- Join the remaining connectors and arrange the cable carefully in the space available within the arch brace. Note that there are two pairs of connectors which may be connected incorrectly.

The male connector on the cable with the red strip must be connected to the female connector on the longer cable.



- Reconnect the instrument panel connector

NOTE

WHEN REFITTING THE CONNECTORS, THE SLIDES MUST MOVE FREELY TO THE END OF STROKE, WHICH HELPS WITH THE INSERTION OF THE CONNECTOR: YOU MUST HEAR THE RELEASE OF THE RETAINING TANG AT THE END OF STROKE.

**Radiator cover**

- Remove the side fairings.
- Remove the fairing lug.
- Working from both sides, unscrew and remove the screw.



- Supporting the radiator cover and working from the right side of the vehicle, unscrew and remove the screw and retrieve the washer and the nut.

**See also**

[Lower cowl](#)

Side fairings

Side air deflectors

The following procedure is for a single lateral duct but is applicable to both.

- Remove the windshield.
- Unscrew and remove the two fixing nuts.



- Remove the duct from its seat on the frame.

CAUTION

DURING REASSEMBLY, THE DUCT MUST BE SEATED CORRECTLY ON THE FRAME TO ENSURE THAT IT IS FLUSH WITH THE ADJACENT PARTS.

See also

Headlight fairing

INDEX OF TOPICS

PRE-DELIVERY

PRE DE

Carry out the listed checks before delivering the motorcycle.

WARNING

HANDLE FUEL WITH CARE.

Aesthetic inspection

- Paintwork
 - Fitting of Plastic Parts
 - Scratches
 - Dirt
-

Tightening torques inspection

- Safety fasteners:
 - front and rear suspension unit
 - front and rear brake calliper retainer unit
 - front and rear wheel unit
 - engine - chassis retainers
 - steering assembly
 - Plastic parts fixing screws
-

Electrical system

- Main switch
 - Headlamps: high beam lights, low beam lights, tail lights (front and rear) and their warning lights
 - Headlight adjustment according to regulations in force
 - Front and rear stop light switches and their bulbs
 - Turn indicators and their warning lights
 - Instrument panel lights
 - Instrument panel: fuel and temperature indicator (if present)
 - Instrument panel warning lights
 - Horn
 - Electric starter
 - Engine stop via emergency stop switch and side stand
 - Helmet compartment electrical opening switch (if present)
-

-
- Through the diagnosis tool, check that the last mapping version is present in the control unit/s and, if required, program the control unit/s again: consult the technical service website to know about available upgrades and details regarding the operation.

CAUTION

TO ENSURE MAXIMUM PERFORMANCE, THE BATTERY MUST BE CHARGED BEFORE USE. INADEQUATE CHARGING OF THE BATTERY WITH A LOW LEVEL OF ELECTROLYTE BEFORE IT IS FIRST USED SHORTENS BATTERY LIFE.

CAUTION

WHEN INSTALLING THE BATTERY, ATTACH THE POSITIVE LEAD FIRST AND THEN THE NEGATIVE ONE, AND PERFORM THE REVERSE OPERATION DURING REMOVAL.

WARNING

THE BATTERY ELECTROLYTE IS POISONOUS AS IT MAY CAUSE SERIOUS BURNS. IT CONTAINS SULPHURIC ACID. AVOID CONTACT WITH YOUR EYES, SKIN AND CLOTHING. IF IT ACCIDENTALLY COMES INTO CONTACT WITH YOUR EYES OR SKIN, WASH WITH ABUNDANT WATER FOR APPROX. 15 MIN. AND SEEK IMMEDIATE MEDICAL ATTENTION. IF ACCIDENTALLY SWALLOWED, IMMEDIATELY DRINK LARGE QUANTITIES OF WATER OR VEGETABLE OIL. SEEK IMMEDIATE MEDICAL ATTENTION. BATTERIES PRODUCE EXPLOSIVE GASES; KEEP CLEAR OF NAKED FLAMES, SPARKS OR CIGARETTES. VENTILATE THE AREA WHEN RECHARGING INDOORS. ALWAYS WEAR EYE PROTECTION WHEN WORKING IN THE PROXIMITY OF BATTERIES. KEEP OUT OF THE REACH OF CHILDREN

CAUTION

NEVER USE FUSES WITH A CAPACITY HIGHER THAN THE RECOMMENDED CAPACITY. USING A FUSE OF UNSUITABLE RATING MAY SERIOUSLY DAMAGE THE VEHICLE OR EVEN CAUSE A FIRE.

Levels check

- Hydraulic braking system fluid level
- Clutch system fluid level (if present)
- Gearbox oil level (if present)
- Transmission oil level (if present)
- Engine coolant level (if present)
- Engine oil level
- Mixer oil level (if present)

Road test

- Cold start
- Instrument panel operation

-
- Response to throttle control
 - Stability when accelerating and braking
 - Front and rear brake efficiency
 - Front and rear suspension efficiency
 - Abnormal noise
-

Static test

Static check after test drive:

- Restarting when warmed up
 - Starter operation (if present)
 - Minimum holding (turning the handlebar)
 - Uniform turning of the steering
 - Possible leaks
 - Radiator electric fan operation (if present)
-

Functional inspection

- Hydraulic braking system
- Stroke of brake and clutch levers (if present)
- Clutch - Check for correct operation
- Engine - Check for correct general operation and absence of abnormal noise
- Other
- Documentation check:
- Chassis and engine numbers check
- Supplied tools check
- License plate fitting
- Locks checking
- Tyre pressure check
- Installation of mirrors and any possible accessories



NEVER EXCEED THE RECOMMENDED INFLATION PRESSURES AS TYRES MAY BURST.

CAUTION



CHECK AND ADJUST TYRE PRESSURE WITH TYRES AT AMBIENT TEMPERATURE.

Specific operations for the vehicle

WARNING

OPERATIONS REQUIRED TO RENDER VEHICLE COMPLIANT WITH TWO SEATER TYPE APPROVAL.

- Remove the screw (2).
- Remove the plastic cover (1).



- Fit the rear pedal in its seat.
- Fit the two TCEI M8X45 screws and tighten with a torque wrench to a torque of 18 Nm (13.27 lbf ft)

**NOTE**

REPEAT THE STEPS TO FIT THE PASSENGER FOOTPEG ON THE OPPOSITE SIDE.

Sostituzione sella

- Insert the key in the lock and turn it clockwise.
- Remove the tail fairing.



- Fit the two-seater saddle.



Regolazione snodo degli specchietti retrovisori

- With the mirror closed (base turned 90° in relation to the mirror) check that the nut is closed properly, as indicated by the arrow, (you should be able to see about 0.5 mm - 1mm (0.02 in - 0.04 in) of the threaded pin projecting from the nut and the Loctite 270).



If the nut is not closed correctly, proceed as follows:

- Close the mirror (base turned 90° in relation to the mirror).
- Remove the glass from the indicator light.



- Cut the cable harness clamp (if there is one), disconnect the cable harness connector and pull the cable harness away from the mirror.



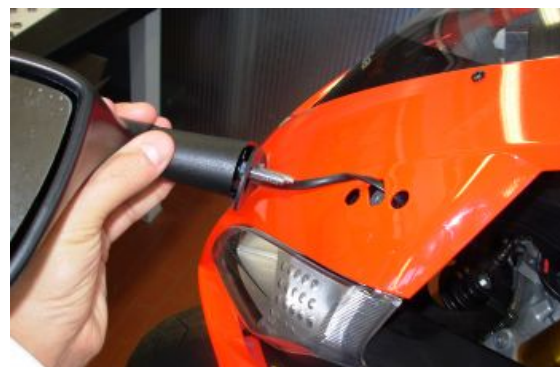


- Loosen the nut so its upper surface is about 0.5 mm (0.02 in) above the end of the threaded pin.
- Put some Loctite 270 inside the nut.



- Screw the nut back down until its upper surface is about 0.5 mm - 1 mm (0.02 in - 0.04 in) away from the end of the pin.
- Wait 24 hours for the Loctite to dry well before moving the mirror.

- Assemble the rear-view mirror.
- Pass the cable harness through the specific hole and place the rear-view mirror in its seat.



- Tighten the two fixing nuts of the rear-view mirror.



- Connect the connector.



A

Air filter: 66

Air temperature sensor: 174

Alternator:

B

Battery: 143, 154

Brake: 452–454, 456, 457, 461, 462

Brake calliper: 452, 453

Brake disc: 453, 454

Brake pads: 456, 457

Brake pump: 461, 462

Bulbs:

Bushings:

C

CAN line: 227

Catalytic converter: 445

Chain: 13, 438, 440

Clutch: 77, 207, 253, 268–270, 272–274, 281, 304, 311, 328, 331

Coil: 189

Connecting rods: 335, 339, 351

Connectors: 220

coolant: 468, 469, 473

Coolant: 468, 469, 473

Countershaft: 328, 329, 333, 338

Crankcase: 326, 333, 337, 354

Crankshaft: 336, 338, 348

Cylinder: 70, 76

D

Desmodromic drum: 256

Drive chain: 13, 438

E

ECU: 221

Electric fan: 210, 466

Electrical system: 13, 95, 98, 502

Engine oil: 64, 448

Engine temperature sensor: 171

Exhaust: 140, 214, 233, 443, 445, 447

Exhaust manifold: 445

F

Fairings: 486, 487, 494, 499

Fork: 381, 385, 391, 400

Forks: 257

Front cylinder head valves: 70

Front head: 285, 292, 296, 297, 321, 333, 335

Front wheel: 377, 378, 386, 455

Fuel: 67, 147, 188, 233, 366, 495

Fuel pump: 147, 188, 366
Fuses: 147

H

Handlebar: 380
Head cover: 68–70, 76, 285, 292, 304, 311
Headlight: 486, 500
Helmet compartment:

I

Identification: 11
Instrument panel: 139, 485, 497
Intake pressure sensor: 166

L

License plate holder:
Linkages: 427

M

Magneto flywheel: 265, 333
Maintenance: 8, 62
Maintenance Table:
Mirrors: 484
Mudguard: 493, 496

O

Oil filter: 66
Oil pressure sensor: 204
Oil sump: 333, 362
One-way valve: 364

P

Pistons: 335, 338, 351
Primary shaft: 256

R

Radiator: 233, 471, 499
Rear cylinder head valves: 76
Rear head: 303, 310, 314, 321, 333, 335
Rear wheel: 416, 419, 454
Recommended products: 51
Ride by wire: 368
Run/Stop switch: 213

S

Saddle:
SAS valve actuator: 212
Secondary air system:
Secondary shaft: 256
Shock absorber:
Shock absorbers: 424
Side fairings: 487
Side stand: 208, 442
Side stand sensor: 208
Spark plug: 63, 68, 69
Speed sensor: 155

Stand: 208, 233, 236, 441, 442

Start-up: 146, 262

Starter motor: 262

Steering damper: 410

Stepper motor: 372

T

Tank: 67, 233, 495

Throttle body: 68, 69, 193, 370–372

Transmission: 12, 330, 333

Tyres: 14

V

Variable geometry intake: 156, 372, 374

W

Warning lights:

Water pump: 333, 357, 469

Windshield:

Wiring diagram: 134