

# RONDA mastertech 8000

XXL Chronographs,  
Retrograde and Big Date

*Caliber 8040.B – 15'''*

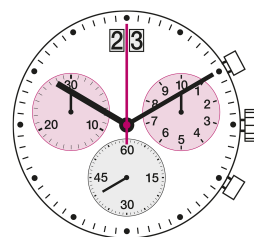

## Product Specifications

Analog quartz movement

Line mastertech

Caliber 8040.B

Size 15'''

Version Swiss Made 13 Jewels / gold plated

Standard battery life 48 months

Hand fitting height 1

## Features

- Repairable metal watch movement
- Very long battery life
- Power saving mechanism with pulled out stem: Reduction of consumption approximately 70%
- Very easy handling by two pushers
- Big date with quick change

**Functions**

- 3 eyes
- Chronograph
- Center stop second (1/1 sec)
- 1/10 seconds up to 30 minutes
- 30 minute counter
- 10 hour counter
- ADD and SPLIT functions
- Big date
- Small second

**Technical Specifications**

Diameter Total	34.60 mm
Case fitting	33.80 mm
Movement height	5.60 mm
Height over standard battery	5.60 mm
Movement rest	0.60 mm
Height over stem	3.30 mm
Length of stem travel	1.00 mm
Force to push the stem for screwed crown	10 / 15 N
Stem thread	0.90 mm
Standard battery	395
Standard battery life	48 months
Battery voltage	1.5 V
Current consumption – typical	1.48 $\mu$ A (Date Mechanism not in Gear)
Current consumption – maximum	2 $\mu$ A (Date Mechanism not in Gear)
Useful torque second – typical	6 $\mu$ Nm
Useful torque minute – typical	300 $\mu$ Nm
Useful torque center stop second – typical	7 $\mu$ Nm
Operating temperature	0 - 50 °C
Instantaneous rate	-10/ +20 sec/month
Resistance to magnetic fields	18.8 Oe
Resistance against shock	NIHS 91-10



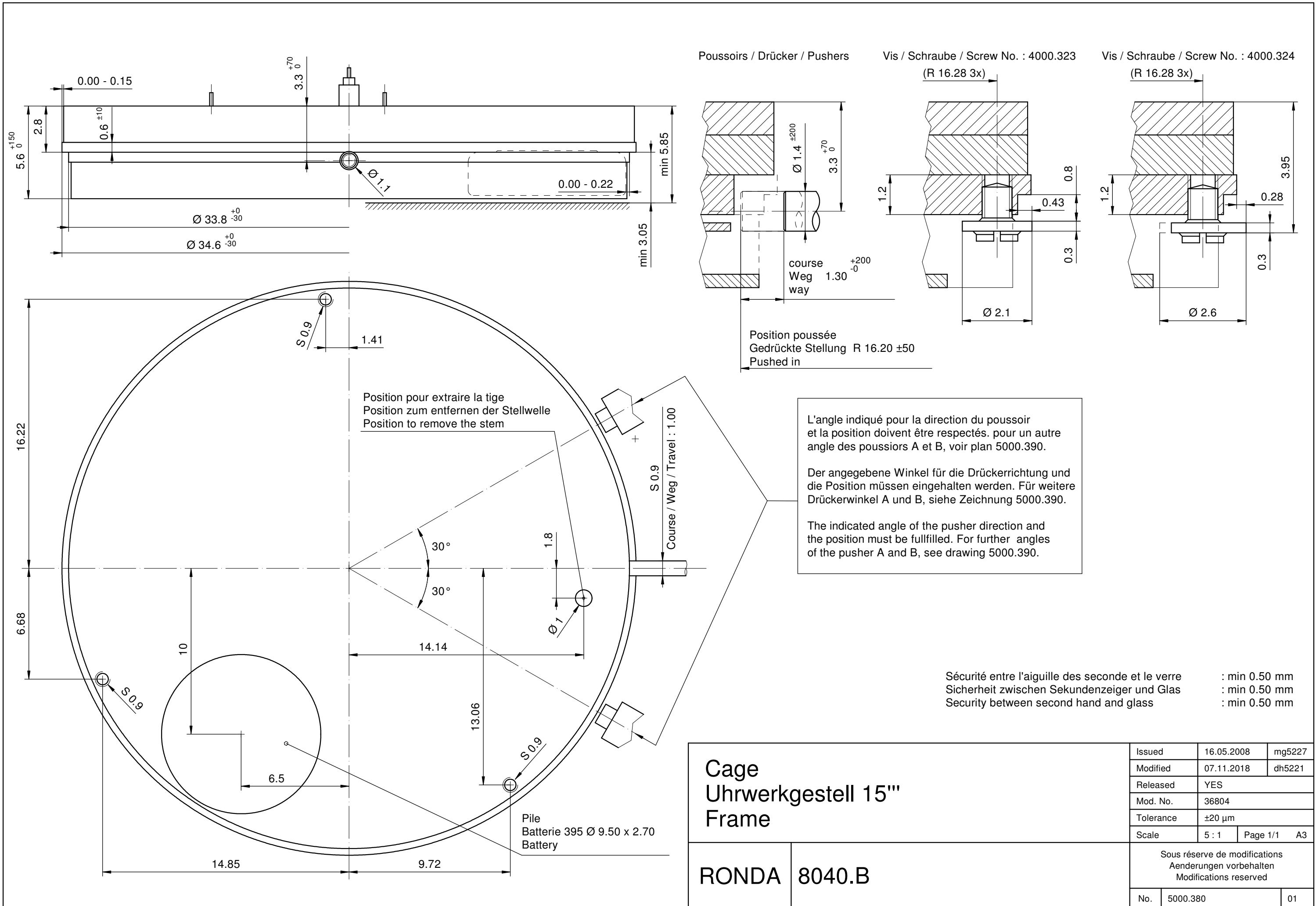

Cage Uhrwerkgestell 15" Frame		Issued	16.05.2008	mg5227
		Modified	07.11.2018	dh5221
RONDA 8040.B		Released	YES	
		Mod. No.	36804	
		Tolerance	±20 µm	
		Scale	5 : 1	Page 1/1
		Sous réserve de modifications Änderungen vorbehalten Modifications reserved		
No.	5000.380	01		

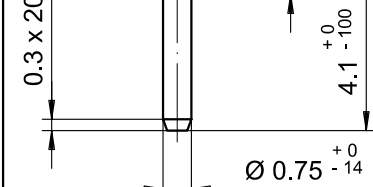
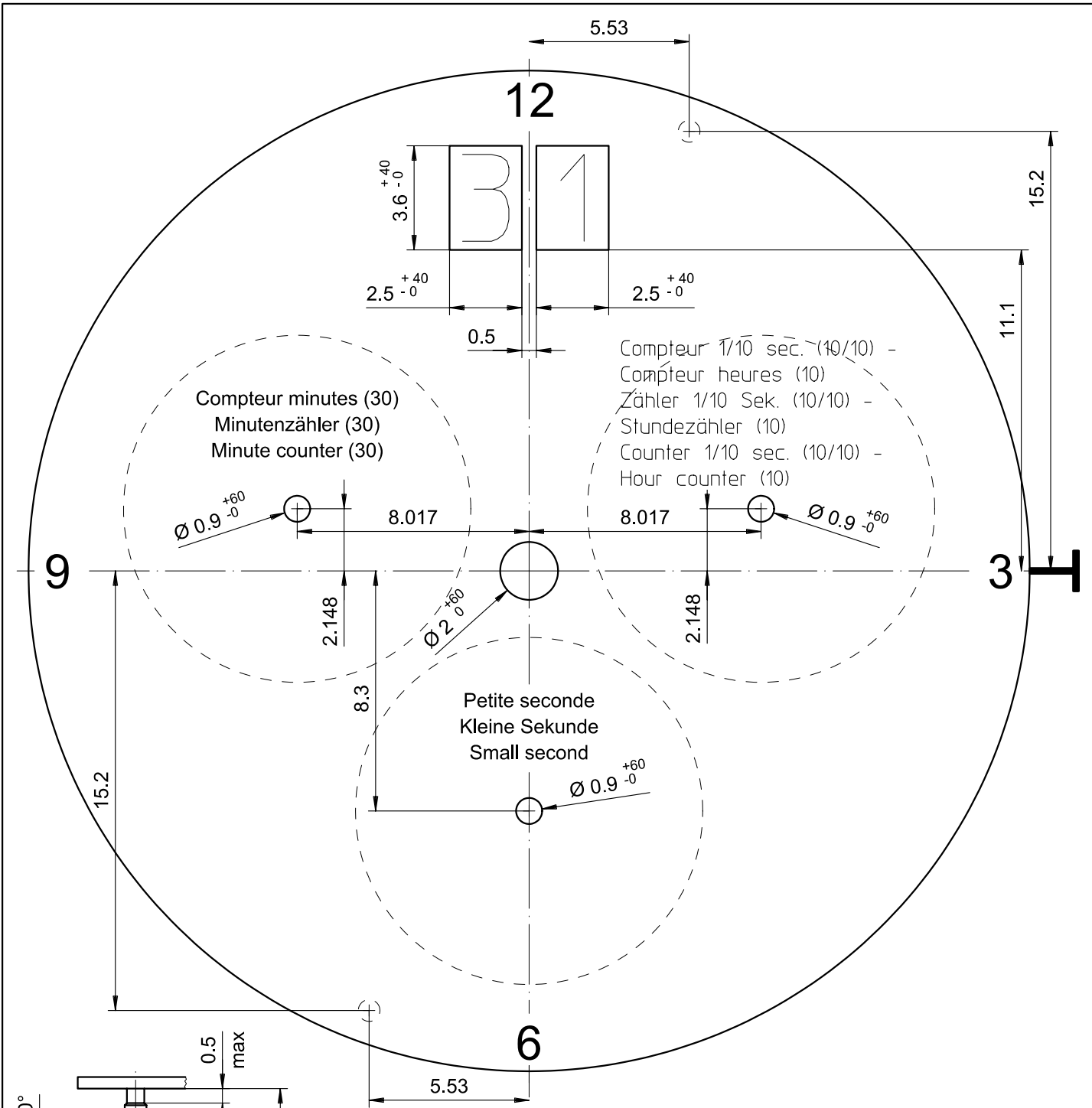

Epaisseur du cadran selon hauteur de l'aiguillage  
 Zifferblattdicke gemäss Zeigerwerkhöhen  
 Dial thickness according to hand fitting heights

Tige	Date
Stellw.	Datum
Stem	Date
<b>3H</b>	<b>12H</b>

<b>Cadran</b> <b>Zifferblatt</b> <b>Dial</b>	<b>15'''</b>	Issued	16 Mai 2008	mg
		Modified	12 Feb 2010 ÄA 5198	fl
		Released	YES	
		Tolerance	+/- 20 µm	
		Scale	5 : 1 (A4V)	
<b>RONDA</b>	<b>8040.B</b>	Sous réserve de modifications Aenderungen vorbehalten Modifications reserved		
		No.	5010.805	00

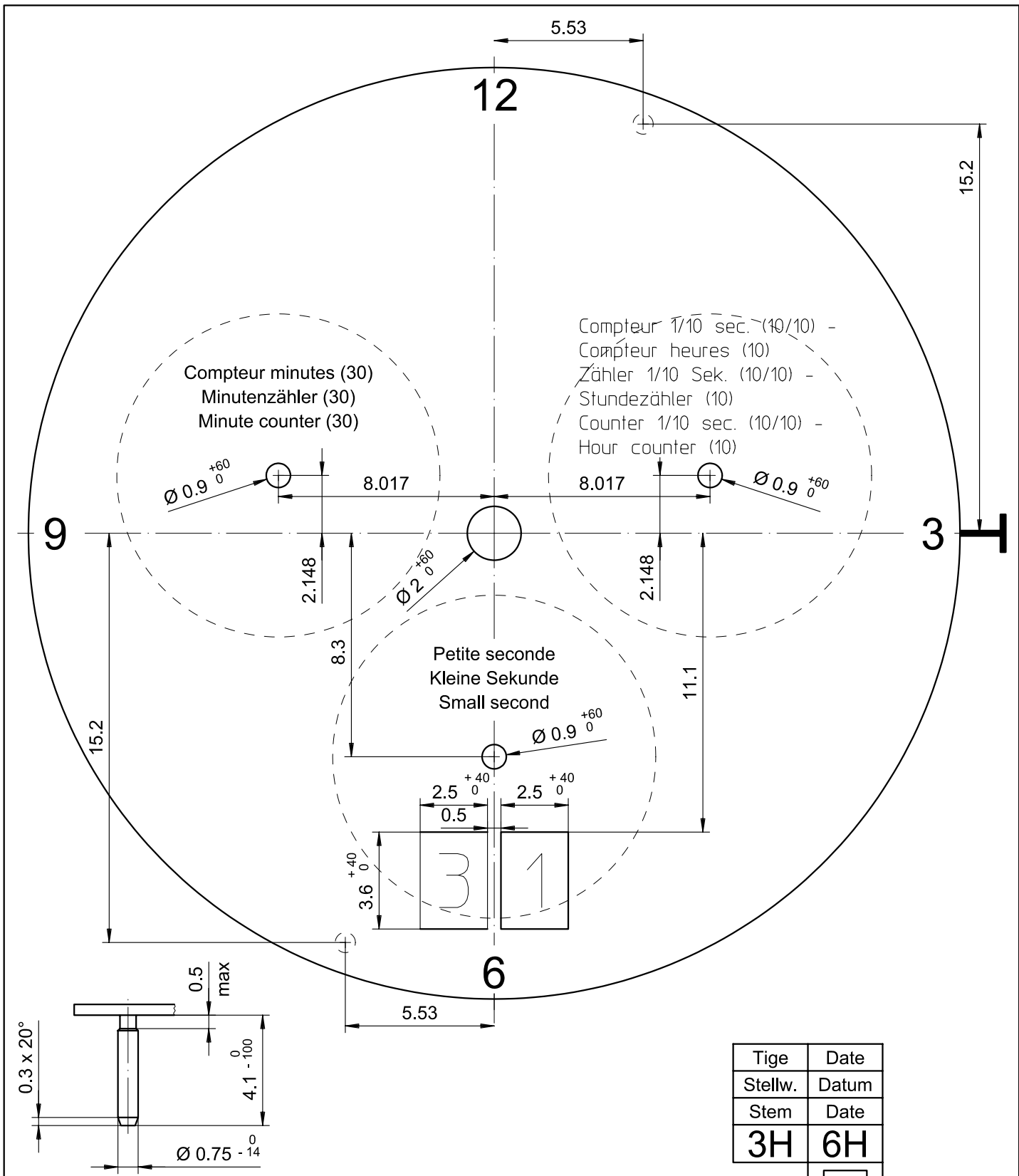

Tige	Date
Stellw.	Datum
Stem	Date
<b>3H</b>	<b>6H</b>
□	

Epaisseur du cadran selon hauteur de l'aiguillage  
Zifferblattdicke gemäss Zeigerwerkhöhen  
Dial thickness according to hand fitting heights

<b>Cadran</b> <b>Zifferblatt</b> <b>Dial</b>	<b>15'''</b>	Issued	06.12.2010	dh
		Modified	06.12.20100 ÄA 10074	dh
		Released	YES	
		Tolerance	+/- 20 µm	
		Scale	5 : 1 (A4V)	
<b>RONDA</b>	<b>8040.B</b>	Sous réserve de modifications Änderungen vorbehalten Modifications reserved		
		No.	5010.014	00

Ajustement aiguille des minutes  
Minutenzeigerpassung  
Minute hand fitting

Ajustement aiguille des heures  
Stundenzeigerpassung  
Hour hand fitting

Ajustement aiguille des secondes chrono  
Stopp-Sekundenzeigerpassung  
Chrono second hand fitting

Ajustement aiguille  
Zeigerpassung  
Hand fitting

Ajustement aiguille  
Zeigerpassung  
Hand fitting

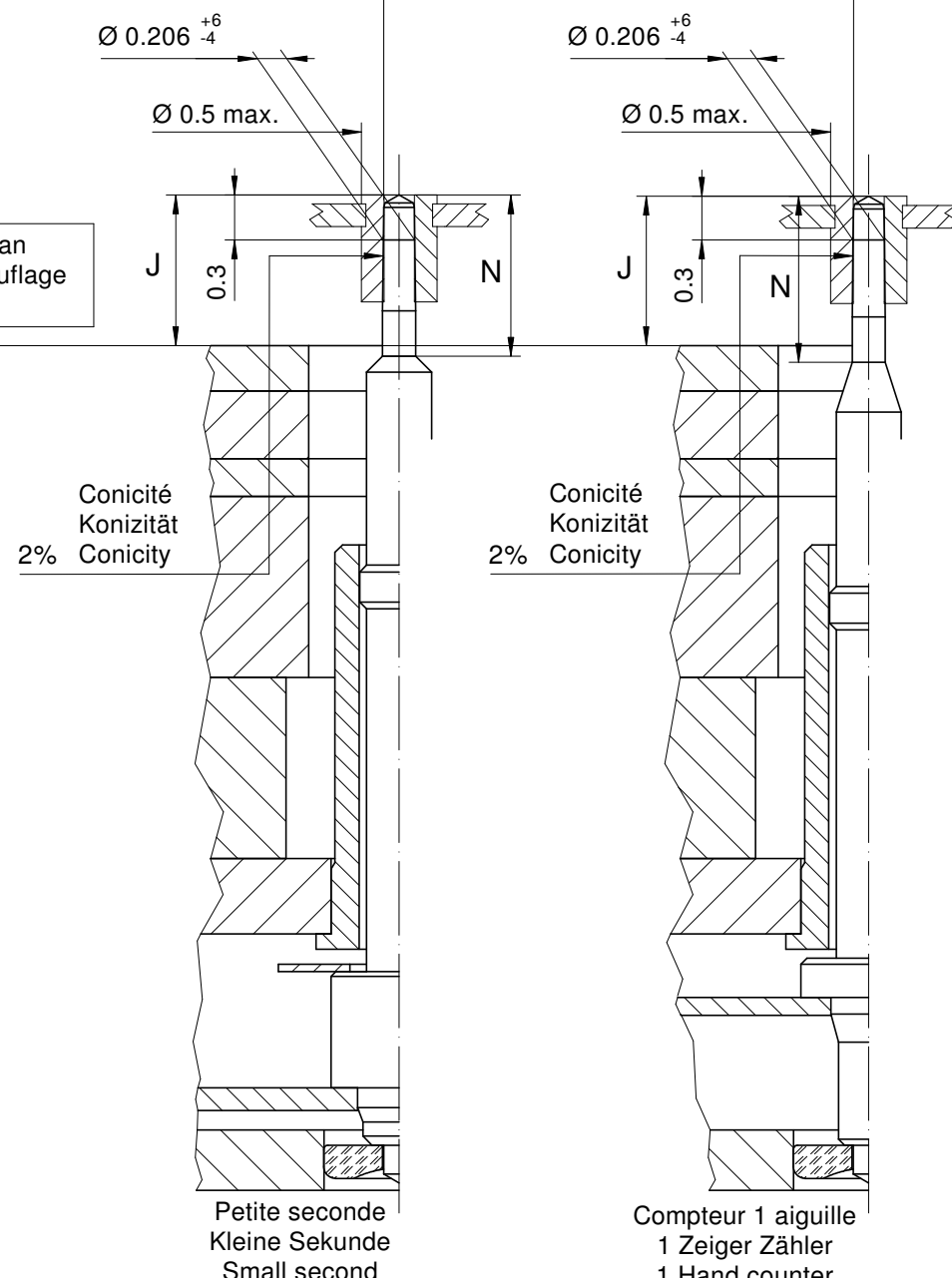
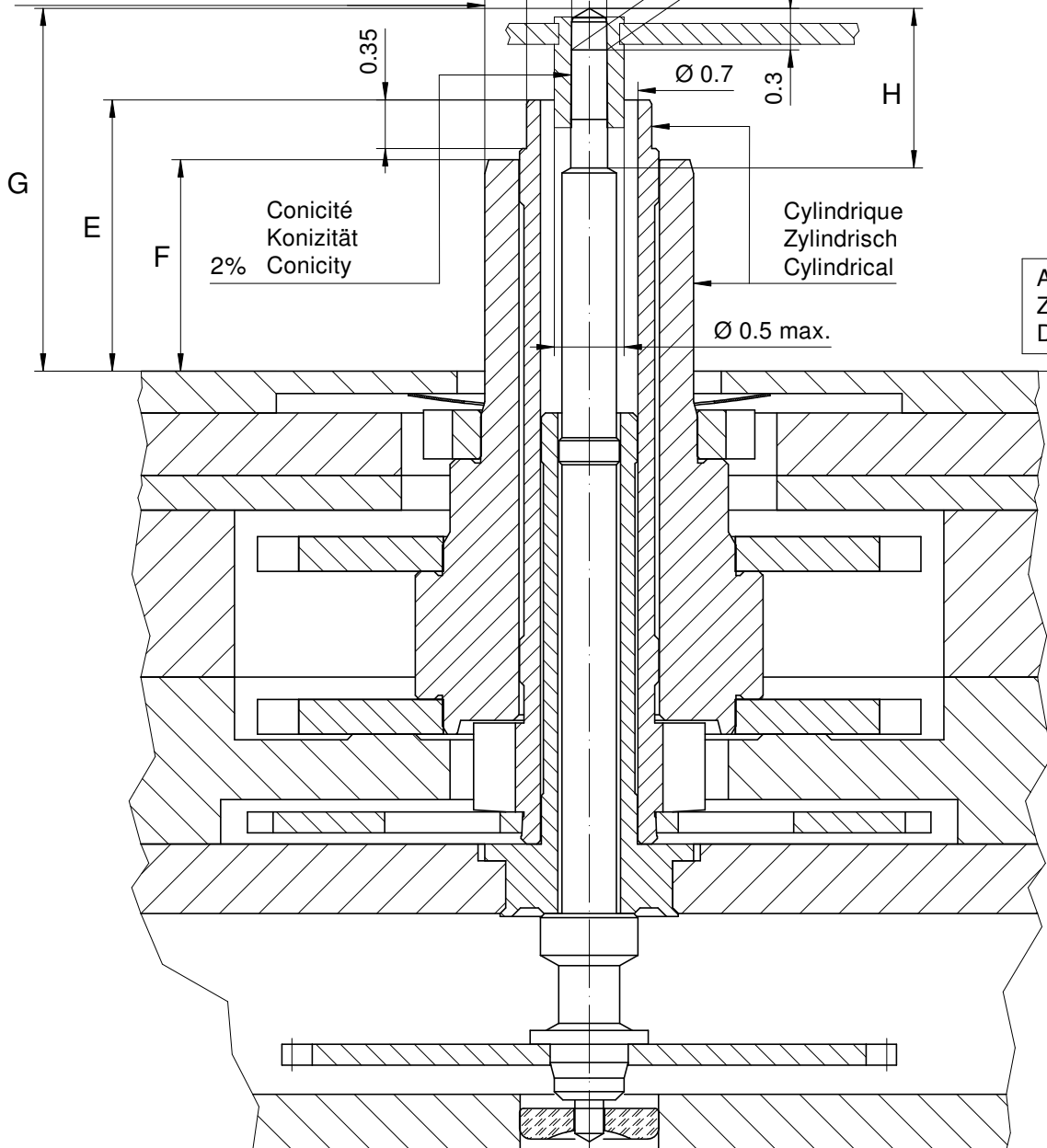

Heures / minutes / secondes chrono  
Stunden / Minuten / Stopp-Sekunden  
Hours / minutes / chrono seconds

Petite seconde  
Kleine Sekunde  
Small second

Compteur 1 aiguille  
1 Zeiger Zähler  
1 Hand counter

Aiguillages Zeigerwerkhöhe Hand fitting height							
Dépassement Höhe über Zifferblattauflage Height over dial seat							
No	G	E	F	H	N	J	J
1	2.61	1.95	1.52	1.15	1.05	1.00	1.00
-							

Aiguillages Zeigerwerkhöhe Hand fitting height						
Peinture comprise / inkl. Farbe / Paint included						
Epaisseur maximum du cadran Maximale Zifferblattdicke Maximum dial thickness						
No	Sous l'aiguille des secondes chrono Unter Stopp-Sekundenzeiger Under chrono second hand	Sous l'aiguille des minutes Unter Minutenzeiger Under minute hand	Sous l'aiguille des heures Unter Stundenzeiger Under hour hand	Sous l'aiguille de petite seconde Unter kleine Sekundenzeiger Under small second hand	Sous l'aiguille compteur 1 aiguille Unter Zeiger 1 Zeiger Zähler Under hand 1 hand counter	Epaisseur des aiguilles Zeigerdicke Hands thickness
1	2.10	1.55	1.10	0.55	0.55	0.15
-						

	Aig. des sec. chrono Stopp-Sekundenzeiger Chrono second hand	Aig. des minutes Minutenzeiger Minute hand	Aig. des heures Stundenzeiger Hour hand	Aig. petite secondes Kleine Sekundenzeiger Small second hand	Aiguille compteur minute Zähler Zeiger Minute Counter hand minute	Aiguille compteur 1/10 sec. Zähler Zeiger 1/10 Sek. Counter hand 1/10 sec.	Lors de la pose d'aiguilles, le mouvement doit être soutenu. Beim Zeigersetzen muss das Werk abgestützt werden. The movement needs to be supported for hand setting.
mg max.	10	30	30	10	10	10	Masse / Masse / weight
µNm max.	0.06	0.80	0.80	0.07	0.03	0.02	Balourd / Unwucht / unbalance
gmm <sup>2</sup> max.	1.0	--	--	0.4	1.0	1.0	Inertie / Massenträgheit / Inertia
N max.	30	40	40	30	30	30	Force de chassage / Aufpresskraft / Force

<h2>Aiguillages Zeigerwerkhöhen 15 ''' Hand fitting heights</h2> <p><b>RONDA 8040.B</b></p>		Issued	02 Jun 2008	mg
		Modified	15 Okt 2014 ÄÄ 13275	dh
		Released	Yes	
		Tolerance	µm	
		Scale	20 : 1 (A3H)	
		Sous réserve de modifications Aenderungen vorbehalten Modifications reserved		
No.	3316.123	02		

\* En cas de données différentes, veuillez contacter le service après-vente

\* Bei abweichenden Werten, bitte technischen Kundendienst anfragen

\* In case of different values, please contact the customer service

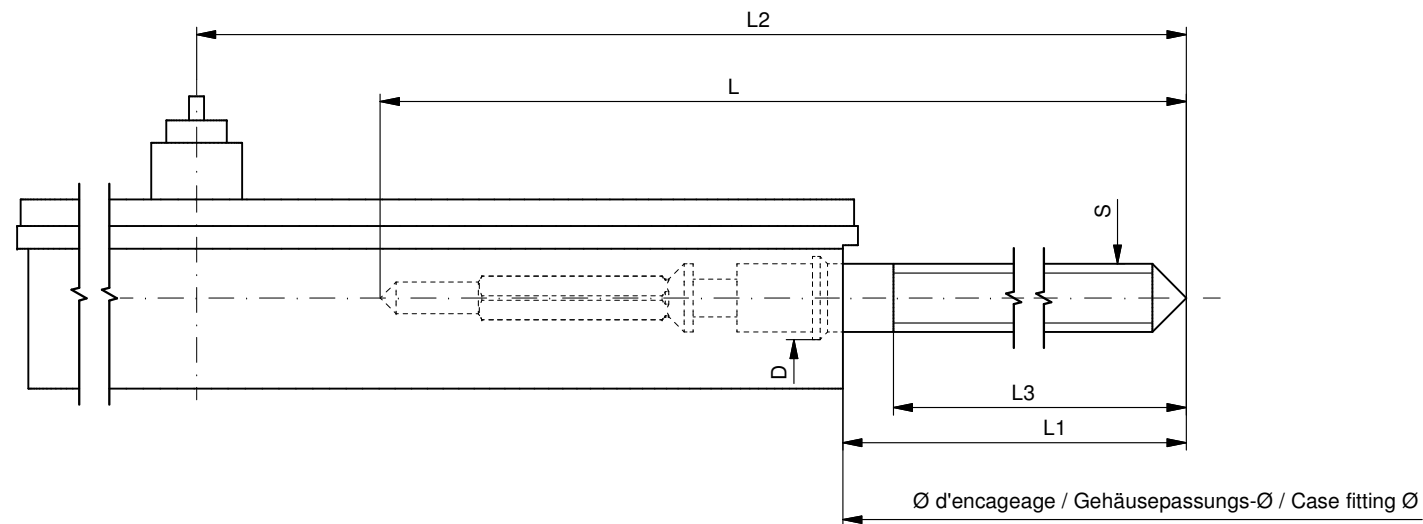

Tige de travail (intégrée dans le mouvement)  
 Arbeitstellwelle (im Werk eingebaut)  
 Working stem (implemented in the movement)

No. d'article Artikelnummer Part number	L	L1	L2	L3	S	D
3000.203.CO	21.30	11.67	28.57	11.12	0.90	1.10

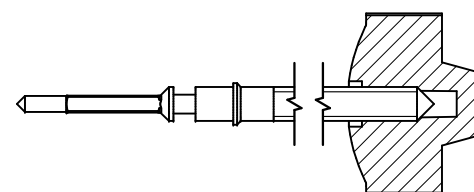

Couleur de la couronne Kronenfarbe Crown color	gris foncé dunkelgrau dark grey
Code	UN 7005

Tige (normale) / Stellwelle (normal) / Stem (normal)

No. d'article Artikelnummer Part number	L	L1	L2	L3	S	D
3000.203	21.30	11.67	28.57	11.12	0.90	1.10

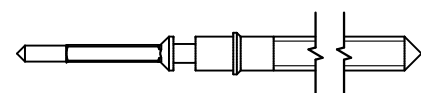

Couronne normale  
 Normale Krone  
 Normal crown

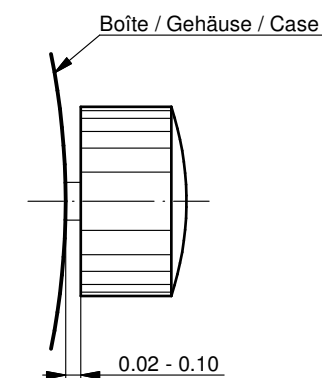

Couronne vissée  
 Geschraubte Krone  
 Screwed crown

Force ⇐ min. Kraft ⇐ min. Force ⇐ min.	10 N
Force ⇐ max. Kraft ⇐ max. Force ⇐ max.	15 N

Rallonge de tige / Stellwelle Verlängerung / Stem extension

No. d'article Artikelnummer Part number	L4	L5 (min)	L6	S1	S2	D1
3000.040	12.00	1.90	2.60	0.90	0.90	1.35

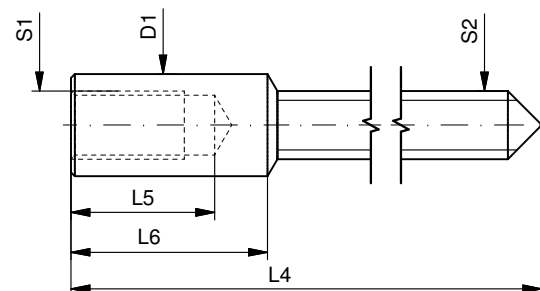

Tige (dimensions / forces)  
 Stellwelle (Dimensionen / Kräfte)  
 Stem (dimensions / forces)

RONDA 8040.B, 8040.N

Issued	07 Sep 2012	ds5222
Modified	25 Apr 2017 ÄA 34582	mg5224
Released	YES	
Tolerance	---	
Scale	10:1 (A3)	

Sous réserve de modifications  
 Änderungen vorbehalten  
 Modifications reserved

No.	5030.023	01
-----	----------	----



**Movement holder**  
Removing setting stem  
H8XXX.1T



**Movement holder**  
Setting hands  
H8XXX.1A

**Fitting dial and hands**

- Crown in position II
- Wind crown, until date 02 appears
- Crown in position III
- Wind hour hand forwards, until date changes to 03
- Remove working hand
- Fit dial
- Point all hands towards 12 o'clock
- Set time
- Zero chrono hand\*
- Crown in position II
- Set date
- Crown in position I

**Date switching duration**

First and tenth digit discs

~2hrs

**\*Zeroing chronograph hand**

- Activate pushers A and B for 2 seconds at the same time  
(Chrono seconds hand rotates once)
- Pusher A → to correct chrono seconds hand
- Pusher B → to jump to hour hand
- Pusher A → to correct hand position
- Pusher B → Jo jump to minute hand
- Pusher A → to correct minute hand

**Details:** See Instruction Manual

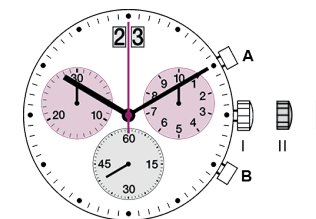
**General Instructions**

Removing the setting stem can only be effected in Pos. I.

The use of supporting screws is essential when mounting the hands.

Permitted hand setting strengths:

Hr / min. hands: <40N

Other hands: <30N

During quick date correction (setting stem in position II), a date switching speed of 5 d/s must not be exceeded.



You have decided to buy a watch, which was assembled by a watchmaker using a Ronda movement. Please note that no watches are produced or distributed under the Ronda brand.

**In case of repairs, guarantee claims and questions concerning the functioning of a watch, purchasers and consumers should contact their retailer or the watch manufacturer, for which the relevant information can be found in the sales or guarantee documentation provided with the watch.**

**Description of the display and control buttons**

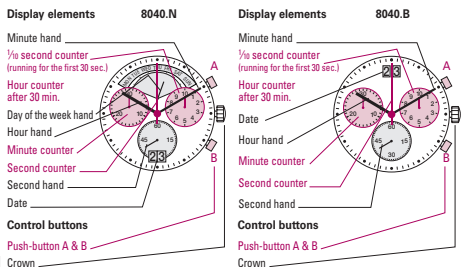

**Chronograph: Basic function**

(Start / Stop / Reset)

Example:

- Start:** Press push-button A.
- Stop:** to stop the timing, press push-button A once more and read the chronograph counters:  
4 min / 38 sec / 1/2 sec
- Zero positioning:** Press push-button B. (The chronograph hands will be reset to their zero positions.)

05

**Chronograph: Accumulated timing**

Example:

- Start:** (start timing)
- Stop:** (e.g. 15 min 5 sec following 1)
- Restart:** (timing is resumed)
- Stop:** (e.g. 5 min 12 sec following 3)  
= 20 min 17 sec  
(The accumulated measured time is shown)

**Reset:** The chronograph hands are returned to their zero positions.

**Please note:** Following 4, the accumulation of the timing can be continued by pressing push-button A (Restart / Stop, Restart / Stop, ...).

06

**Chronograph: Intermediate or interval timing**

Example:

- Start:** (start timing)
- Display interval:** e.g. 20 minutes 17 seconds (timing continues in the background)
- Making up the measured time:** (the chronograph hands are quickly advanced to the ongoing measured time.)
- Stop:** (Final time is displayed)
- Reset:** The chronograph hands are returned to their zero position.

**Please note:** Following 4, further intervals or intermediates can be displayed by pressing push-button B (display interval / make up measured time, ...).

07

**Setting the time**

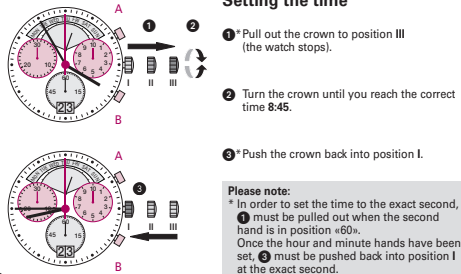

02

**Adjusting the chronograph hands to zero position**

Example:  
One or several chronograph hands are not in their correct zero positions and have to be adjusted (e.g. following a battery change).

- Pull out the crown to position III (all chronograph hands are in their correct or incorrect zero position.)
- Keep push-buttons A and B depressed simultaneously for at least 2 seconds (the second counter hand rotates by 360° → corrective mode is activated.)

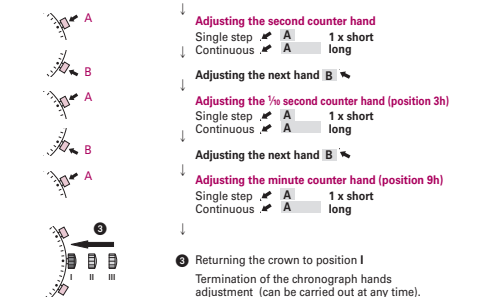

08

**Setting the date (quick mode)**

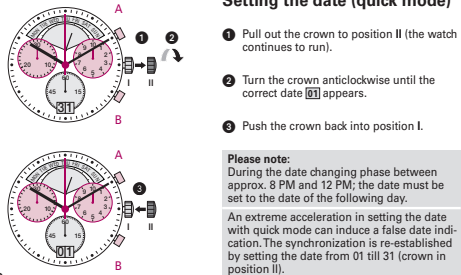

03

**Setting the date, day of the week (8040.N), time**

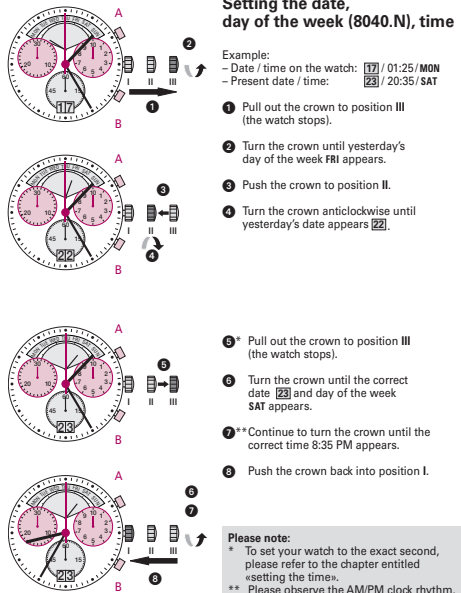

04







Battery type: 395 / SR927SW  
 Accuracy: +20 / -10 seconds per month

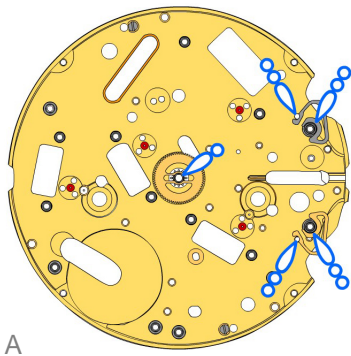





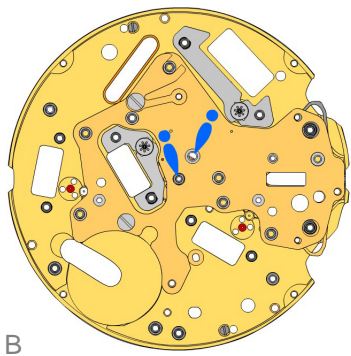

07/2017











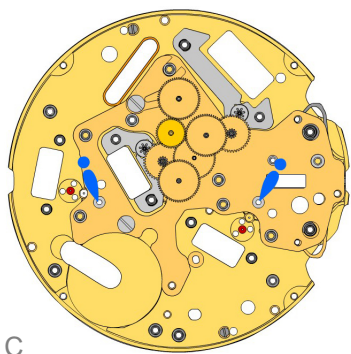

2000.700.G 1.		Main plate
3406.038 2.		Pusher jumper A Put the yellow jumper between the two posts on the closer side.
3406.030 3.		Pusher jumper B Put the grey jumper between the two posts on the further side.
3305.364.CO 4.		Canon pinion (Aig.1)



2030.029 5.		Center bridge Center bride held by 2 screws 4000.250.
4000.250 6.		Screw
3406.040 7.		Friction spring Friction spring held by 1 screw 4000.250.
4000.250 8.		Screw
3622.055 9.		Stator
3622.054 10.		Stator chrono Mark  1  on stator.
3715.119.RK 11.		Rotor
3715.119.RK 12.		Rotor



3147.073.CO 13.		Intermediate wheel
3147.074.CO 14.		Intermediate wheel chrono
3122.067.CO 15.		Third wheel
3136.180.CO 16.		Chronograph wheel
3136.179.CO 17.		Second wheel
3136.178.CO 18.		Small second wheel
3004.203.CO 19.		Reverse wheel

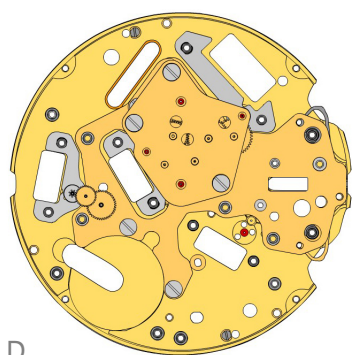

D

2020.188.G  
20.  **Train wheel bridge**  
Train wheel bridge held by 2 screws 4000.250.

4000.250  
21.  **Screw**

3622.039  
22.  **Stator**

3402.012.CO  
23.  **Minute counting wheel (30min)**

3715.120.RK  
24.  **Rotor**

3147.076.CO  
25.  **Intermediate wheel (counter 30min)**

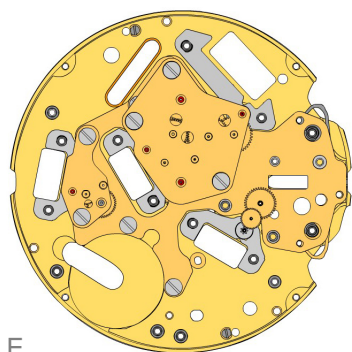

E

2020.191.G  
26.  **Counter train wheel bridge (9h30)**  
Train wheel bridge held by 2 screws 40000.250. Mark [2].

4000.250  
27.  **Screw**

3622.039  
28.  **Stator**

3402.013.CO  
29.  **Counting wheel (1/10 s)**

3715.120.RK  
30.  **Rotor**

3147.075.CO  
31.  **Intermediate wheel (counter 1/10 s)**

2020.190.G  
32.  **Counter train wheel bridge (2h30)**  
Train wheel bridge held by 2 screws 40000.250. Mark [2].

4000.250  
33.  **Screw**

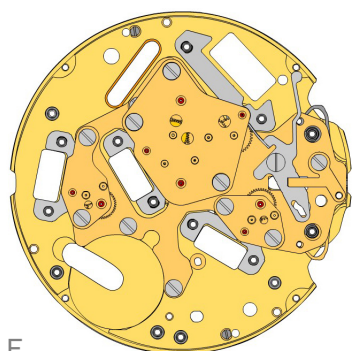

F





3016.029  
34.  **Stop lever**  
Stop lever held by 1 screw 4000.249.

4000.249  
35.  **Screw**

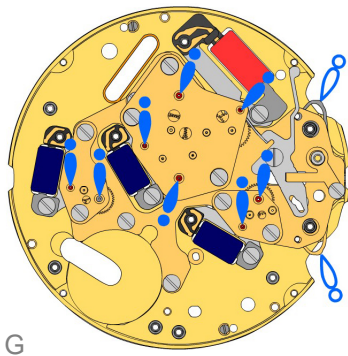



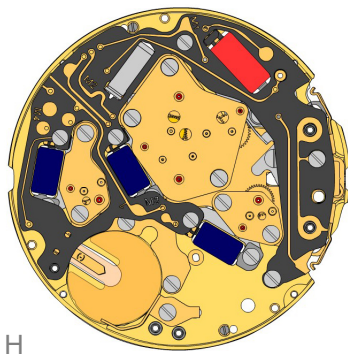

2130.222  
36.  **Maintaining plate**  
Maintaining plate held by 1 screw 4000.248

4000.248  
37.  **Screw**







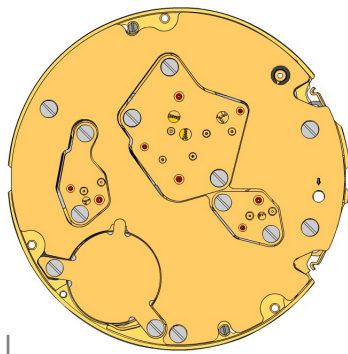

3621.072.RK 38.		<b>Coil</b> Attention: Please don't hold the coil on the black side. Else the wire support can break.
3621.055.RK 39.		<b>Coil counter</b> Attention: Please don't hold the coils on the black side. Else the wire support can break.
3621.055.RK 40.		<b>Coil counter</b> Attention: Please don't hold the coils on the black side. Else the wire support can break.
3621.055.RK 41.		<b>Coil counter</b> Attention: Please don't hold the coils on the black side. Else the wire support can break.
4000.250 42.		<b>Screw</b>



3603.089 43.		<b>Battery insulator</b>
3601.134 44.		<b>Pusher contact spring</b>
3612.218 45.		<b>Electronic module</b> Electronic module held by 6 screws.
4000.248 46.		<b>Screw</b> 4 screws 4000.248 for pressing the module on the coils.
4000.250 47.		<b>Screw</b> 2 screws 4000.248 for pressing the module on the 2 posts.
3601.132.G 48.		<b>Lateral bridle</b> Lateral bridle held by 1 screw 4000.250.
4000.250 49.		<b>Screw</b>



3603.090 50.		<b>Circuit insulator</b>
2130.206.G.M01.8040B 51.		<b>Electronic module cover</b> Electronic module cover held by 4 screws 4000.250
4000.250 52.		<b>Screw</b>
3600.010.HGF 53.		<b>Battery 395</b>
3601.133.G 54.		<b>Bridle +</b> Bridle + held by 2 screws 4000.250.
4000.250 55.		<b>Screw</b>

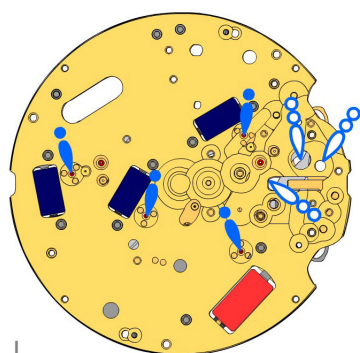

J

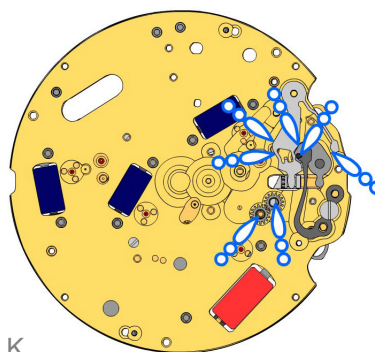

K

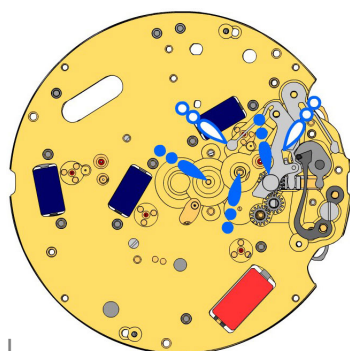

L

 2000.700.G  
56.

Main plate

 3017.054.CO  
57.

Setting lever

 3001.046  
58.

Sliding pinion

 3015.088  
59.

Yoke

 3905.063  
60.

 Setting lever jumper  
Lever held by 1 screw 4000.282

 4000.282  
61.

Screw

 3004.200  
62.



Corrector setting wheel

 3004.200  
63.

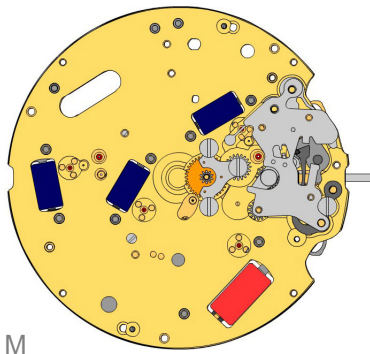

Corrector setting wheel

 3015.087.CO  
64.



Setting wheel yoke

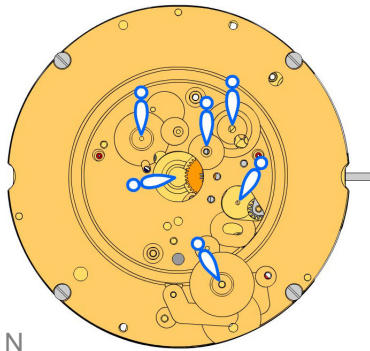

M

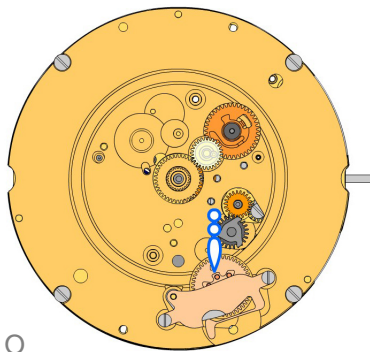

N





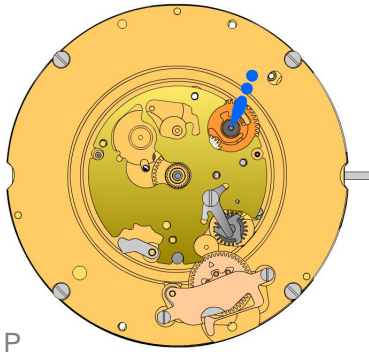

O





2130.208 65.		<b>Setting mecanism cover</b> Setting meca cover held by 4 screws 4000.305.
4000.305 66.		<b>Screw</b>
3000.203.CO 67.		<b>Setting stem</b> Attention on the right position of the sliding pinion.
3004.222 68.		<b>Intermediate setting wheel</b>
3007.079.CO 69.		<b>Minute wheel</b>
2130.209 70.		<b>Minute train bridge</b> Minute train bridge held by 3 screws 4000.278.
4000.278 71.		<b>Screw</b>
2000.671.G 72.		<b>Main plate retro</b> Minute train bridge held by 4 screws 4000.248.
4000.248 73.		<b>Screw</b>
3004.220 74.		<b>Tens indicator driving wheel</b> The short tooth of the tens indicator driving wheel must point to the center of the movement.
3500.072 75.		<b>Tens jumper</b>
2130.187 76.		<b>Tens jumper maintaining plate</b> Tens jumper maintaining plate held by 2 screws 4000.279. Tensioning the spring arm.
4000.279 77.		<b>Screw</b>
3301.292.CO 78.		<b>Hour wheel</b>
3004.208.CO 79.		<b>Date indicator driving wheel</b>
3147.061 80.		<b>Intermediate date wheel</b>
3147.066.CO 81.		<b>Date corrector setting wheel</b>







**P**





**Q**

**R**

2130.188 82.		Date indicator plate
3905.068 83.		Date corrector spring Date corrector spring held by 1 screw 4000.244.
4000.244 84.		Screw
3500.068 85.		Date jumper

3504.229.AF.1.A 86.		Units indicator (standard) Nick of the indicator at 3 o'clock.
2130.189 87.		Date indicator maintaining plate Date indicator maintaining plate held by 1 screw.
4000.250 88.		Screw
3905.064 89.		Date jumper spring Insert the date jumper spring in the previous opening.
3147.062 90.		Tens intermediate wheel Arrow positioning radially outwards.

3504.230.AF.1.A 91.		Tens indicator (standard) Nick of the indicator at 3 o'clock.
3315.003 92.		Friction spring
2130.190.G 93.		Date mechanism maintaining plate Date mechanism maintaining plate held by 3 screws 4000.320.
4000.320 94.		Screw
3506.077.G 95.		Intermediate Dial support Polished version first.
3506.076.G 96.		Dial support

8200 97.		Moebius 8200
9014 98.		Moebius 9014
124 99.		Jismaa 124
9020 100.		Moebius 9020

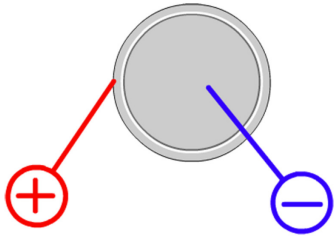

Battery	<b>395</b>
Voltage	<b>1.55 V</b>

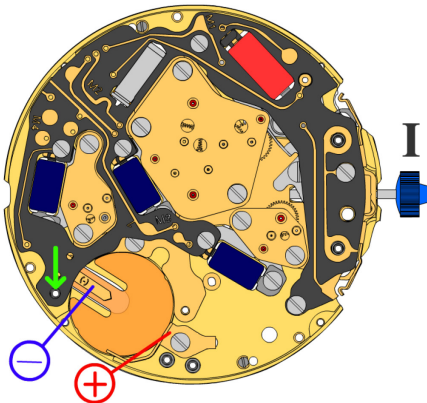

*Setting stem in position I, calendar not in gear,  
60 s measuring interval for rate and consumption:*

Typical consumption	<b>1.48 <math>\mu</math>A</b>
Maximal consumption	<b>2.00 <math>\mu</math>A</b>
Rate	<b>-10s/M. .. +20s/M.</b>
Lower working voltage limit	<b>1.20 V</b>

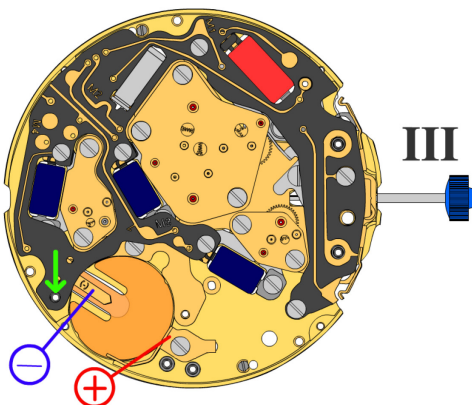

*Setting stem in position III, 60 s measuring interval:*

Typical consumption	<b>0.10 <math>\mu</math>A</b>
Maximal consumption	<b>0.30 <math>\mu</math>A</b>



*Hold down the electrical module to allow the electronic flow.*



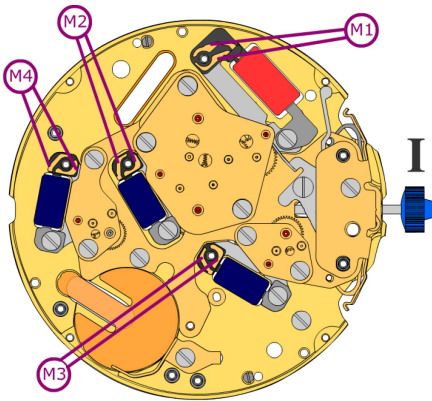

Coil resistance M1 **1.50 k $\Omega$  .. 1.70 k $\Omega$**

Coil resistance M2 **1.68 k $\Omega$  .. 1.88 k $\Omega$**

Coil resistance M3 **1.68 k $\Omega$  .. 1.88 k $\Omega$**

Coil resistance M4 **1.68 k $\Omega$  .. 1.88 k $\Omega$**

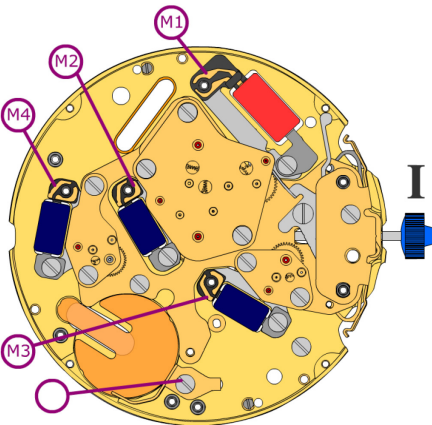

Coil isolation M1/M2/M3/M4  **$\infty$  k $\Omega$**

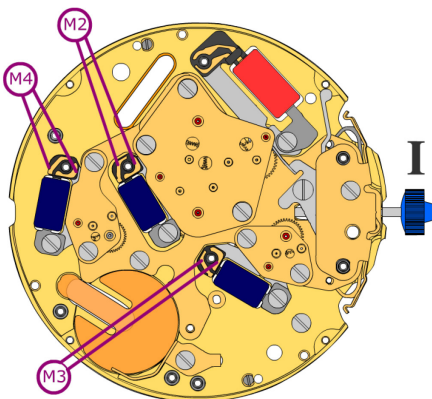

*Signal generator (4.9 ms, 8 Hz):*

Lower working voltage limit  
M2/M3/M4 **1.20 V**