

DE	Gebrauchsanleitung / Montageanleitung	2
FR	Mode d'emploi / Instructions de montage	3
EN	Instructions for use / assembly instructions	4
IT	Istruzioni per l'uso / Istruzioni per Installazione	5
ES	Modo de empleo / Instrucciones de montaje	6
NL	Gebruiksaanwijzing / Handleiding	7
DK	Brugsanvisning / Monteringsvejledning	8
PT	Instruções para uso / Manual de Instalação	9
PL	Instrukcja obsługi / Instrukcja montażu	10
CS	Návod k použití / Montážní návod	11
SK	Návod na použitie / Montážny návod	12
ZH	用户手册 / 组装说明	13
RU	Руководство пользователя / Инструкция по монтажу	14
FI	Käyttöohje / Asennusohje	15
SV	Bruksanvisning / Monteringsanvisning	16
LT	Vartotojo instrukcija / Montavimo instrukcijos	17
HR	Upute za uporabu / Uputstva za instalaciju	18
TR	Kullanım kılavuzu / Montaj kılavuzu	19
RO	Manual de utilizare / Instrucțiuni de montare	20
EL	Οδηγίες χρήσης / Οδηγία συναρμολόγησης	21
SI	Navodilo za uporabo / Navodila za montažo	22
ET	Kasutusjuhend / Paigaldusjuhend	23
LV	Lietošanas pamācība / Montāžas instrukcija	24
SR	Uputstvo za upotrebu / Uputstvo za montažu	25
NO	Bruksanvisning / Montasjeveiledning	26
BG	Инструкция за употреба / Ръководство за монтаж	27
SQ	Udhëzuesi i përdorimit / Udhëzime rreth montimit	28
AR	دليل الاستخدام / تعليمات التجميع	29
HU	Használati útmutató / Szerelési útmutató	30
JP	取扱説明書 / 施工説明書	32

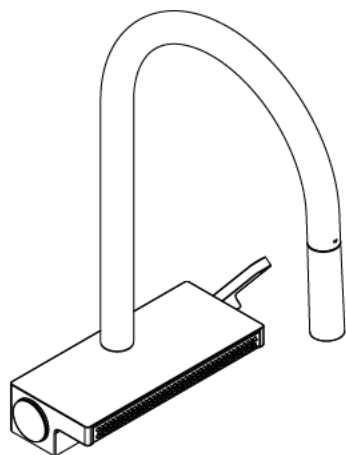

Aquano Select M81 170 3jet sBox
73831XXX / 73834XXX

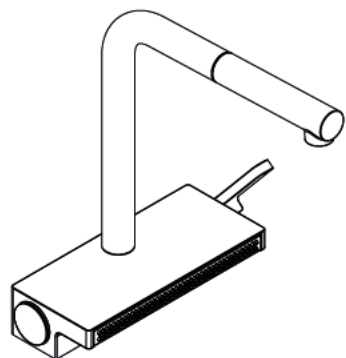

Aquano Select M81 250 2jet sBox
73830XXX / 73835XXX



Sicherheitshinweise

- Bei der Montage müssen zur Vermeidung von Quetsch- und Schnittverletzungen Handschuhe getragen werden.
- Große Druckunterschiede zwischen den Kalt- und Warmwasseranschlüssen müssen ausgeglichen werden.

Montagehinweise

- Vor der Montage muss das Produkt auf Transportschäden untersucht werden. Nach dem Einbau werden keine Transport- oder Oberflächenschäden anerkannt.
- Die Leitungen und die Armatur müssen nach den gültigen Normen montiert, gespült und geprüft werden.
- Die in den Ländern jeweils gültigen Installationsrichtlinien sind einzuhalten.

Technische Daten

Betriebsdruck:	max. 1 MPa
Empfohlener Betriebsdruck:	0,1 - 0,5 MPa
Prüfdruck:	1,6 MPa (1 MPa = 10 bar = 147 PSI)
Heißwassertemperatur:	max. 70 °C
Empfohlene Heißwassertemperatur:	65 °C
Thermische Desinfektion:	max. 70 °C / 4 min

Das Produkt ist ausschließlich für Trinkwasser konzipiert!

Symbolerklärung

 Kein essigsäurehaltiges Silikon verwenden!

Justierung (siehe Seite 41)

Einstellen der Warmwasserbegrenzung. In Verbindung mit Durchlauferhitzern ist eine Warmwassersperre nicht zu empfehlen.

Störung	Ursache	Abhilfe
SatinFlow zu gering / wenig Wasser	- Düsen und / oder Durchflussbegrenzer verschmutzt / verkalkt	- Düsen und Durchflussbegrenzer ausbauen und reinigen.
Umstellung auf SatinFlow klemmt	- Umstellknopf verschmutzt	- Umstellknopf entfernen und reinigen
Armatur tropft	- Kartusche defekt	- Kartusche austauschen
Zu wenig Wasser am Ausziehauslauf	- Rückflussverhinderer im Schlauchanschluss und Strahlregler verkalkt / verschmutzt	- Rückflussverhinderer und Strahlregler reinigen
Wasseraustritt am Befestigungsschaft	- Anschlusschläuche nicht ganz in den Grundkörper eingeschraubt	- Anschlusschläuche von Hand festziehen
Ausziehlänge Schlauch zu kurz (kleiner 500 mm)	- Schlauchgewicht an falsche Position montiert	- Schlauchgewicht entsprechend der Montageanleitung montieren

Wartung (siehe Seite 56)

Rückflussverhinderer müssen gemäß EN 806-5 regelmäßig in Übereinstimmung mit nationalen oder regionalen Bestimmungen auf ihre Funktion geprüft werden (mindestens einmal jährlich).

Maße (siehe Seite 42)

Durchflussdiagramm (siehe Seite 42)

Serviceteile (siehe Seite 48)

XXX = Farbcodierung
000 = Chrom
670 = Mattschwarz
800 = Stainless Steel Optic

Sonderzubehör

(nicht im Lieferumfang enthalten)

 Verlängerung #43333000 (siehe Seite 47)

Reinigung (siehe Seite 56)

Bedienung (siehe Seite 50)

Hansgrohe empfiehlt, morgens oder nach längeren Stagnationszeiten den ersten halben Liter nicht als Trinkwasser zu verwenden.

Prüfzeichen (siehe Seite 50)



Consignes de sécurité

△ Lors du montage, porter des gants de protection pour éviter toute blessure par écrasement ou coupure.

△ Il est conseillé d'équilibrer les pressions de l'eau chaude et froide.

Instructions pour le montage

- Avant son montage, s'assurer que le produit n'a subi aucun dommage pendant le transport. Après le montage, tout dommage de transport ou de surface ne pourra pas être reconnu.
- Les conduites et la robinetterie doivent être montés, rincés et contrôlés selon les normes en vigueur.
- Les directives d'installation en vigueur dans le pays concerné doivent être respectées.

Informations techniques

Pression de service autorisée: max. 1 MPa
 Pression de service conseillée: 0,1 - 0,5 MPa
 Pression maximum de contrôle: 1,6 MPa
 (1 MPa = 10 bar = 147 PSI)
 Température d'eau chaude: max. 70 °C
 Température recommandée: 65 °C
 Désinfection thermique: max. 70 °C / 4 min
 Le produit est exclusivement conçu pour de l'eau potable!

Description du symbole



Ne pas utiliser de silicone contenant de l'acide acétique!



Étalonnage (voir pages 41)

Réglage de la limitation d'eau chaude. En liaison avec les chauffe-eau, un blocage de l'eau chaude n'est pas recommandable.



Entretien (voir pages 56)

Les clapets anti-retour doivent être examinés régulièrement conformément à la norme EN 806-5 ou conformément aux dispositions nationales ou régionales quant à leur fonction (au moins une fois par an).



Dimensions (voir pages 42)



Diagramme du débit

(voir pages 42)



Pièces détachées (voir pages 48)

XXX = Couleurs

000 = Chromé

670 = Matt Black

800 = Stainless Steel Optic

Accessoires en option

(ne fait pas partie de la fourniture)



jeu de rallonge #43333000 (voir pages 47)



Nettoyage (voir pages 56)



Instructions de service

(voir pages 50)

Hansgrohe recommande de ne pas utiliser le premier demi-litre le matin ou après une période de stagnation prolongée.



Classification acoustique et débit

(voir pages 50)

Dysfonctionnement	Origine	Solution
SatinFlow trop faible / peu d'eau	- Buses et / ou limiteur de débit sale / entartré	- Démonter et nettoyer les buses et le limiteur de débit.
Le passage sur SatinFlow coince	- Bouton d'inversion encrassé	- Enlever et nettoyer le bouton d'inversion
Le mitigeur goutte	- Cartouche défectueuse	- Changer la cartouche
Trop peu d'eau au niveau du bec extractible	- Le clapet anti-reflux dans le raccord du tuyau et le régulateur de jet sont entartrés / encrassés	- Nettoyer le clapet anti-reflux et le régulateur de jet
Fuite à la fixation sous le mitigeur	- Les flexibles de raccordement ne sont pas correctement vissés dans le corps.	- Resserer le flexible à la main.
Longueur d'extraction du tuyau trop courte (inférieure à 500 mm)	- Le poids du tuyau est mal positionné	- Monter le poids du tuyau conformément aux instructions de montage



Safety Notes

- ⚠ Gloves should be worn during installation to prevent crushing and cutting injuries.
- ⚠ The hot and cold supplies must be of equal pressures.

Installation Instructions

- Prior to installation, inspect the product for transport damages. After it has been installed, no transport or surface damage will be honoured.
- The pipes and the fixture must be installed, flushed and tested as per the applicable standards.
- The plumbing codes applicable in the respective countries must be observed.

Technical Data

Operating pressure:	max. 1 MPa
Recommended operating pressure:	0,1 - 0,5 MPa
Test pressure:	1,6 MPa (1 MPa = 10 bar = 147 PSI)
Hot water temperature:	max. 70 °C
Recommended hot water temp.:	65 °C
Thermal disinfection:	max. 70 °C / 4 min
The product is exclusively designed for drinking water!	

Symbol description

 Do not use silicone containing acetic acid!

Adjustment (see page 41)

To adjust the hot water limiter. Using a hot water limiter in combination with a continuous flow water heater is not recommended.

Maintenance (see page 56)

The check valves must be checked regularly according to EN 806-5 in accordance with national or regional regulations (at least once a year).

Dimensions (see page 42)

Flow diagram (see page 42)

Spare parts (see page 48)

XXX = Colors
000 = Chrome Plated
670 = Matt Black
800 = Stainless Steel Optic

Special accessories (order as an extra)

 extension #43333000 (see page 47)

Cleaning (see page 56)

Operation (see page 50)

Hansgrohe recommends not to use as drinking water the first half liter of water drawn in the morning or after a prolonged period of non-use.

Test certificate (see page 50)

Fault	Cause	Remedy
SatinFlow too low / little water	- Nozzles and / or flow restrictor fouled / calcified	- Dismantle and clean nozzles and flow restrictor.
Changeover to SatinFlow is stuck	- Changeover button fouled	- Detach and clean changeover button
Mixer dripping	- Cartridge defective	- Exchange cartridge
To little water at the pull-out spout	- Backflow preventer in the hose connection and faucet aerator calcified / fouled	- Clean backflow preventer and faucet aerator
Water escaping at the threaded base	- connection hoses not completely screwed into basic body	- Tighten connection hoses by hand
Pull-out length hose too short (less than 500 mm)	- Hose weight assembled in wrong position	- Assemble hose weight according to the assembly instructions



Indicazioni sulla sicurezza

- ⚠ Durante il montaggio, per evitare ferite da schiacciamento e da taglio bisogna indossare guanti protettivi.
- ⚠ Attenzione! Compensare le differenze di pressione tra i collegamenti dell'acqua fredda e dell'acqua calda.

Istruzioni per il montaggio

- Prima del montaggio è necessario controllare che non ci siano stati danni durante il trasporto. Una volta eseguito il montaggio, non verranno riconosciuti eventuali danni di trasporto o delle superfici.
- Montare, lavare e controllare tubature e rubinetteria rispettando le norme correnti.
- Vanno rispettate le direttive di installazione nazionali vigenti nel rispettivo paese.

Dati tecnici

Pressione d'uso: max. 1 MPa
 Pressione d'uso consigliata: 0,1 - 0,5 MPa
 Pressione di prova: 1,6 MPa
 (1 MPa = 10 bar = 147 PSI)

Temperatura dell'acqua calda: max. 70 °C
 Temp. dell'acqua calda consigliata: 65 °C
 Disinfezione termica: max. 70 °C / 4 min

Il prodotto è concepito esclusivamente per acqua potabile!

Descrizione simbolo



Non utilizzare silicone contenente acido acetico!



Taratura (vedi pagg. 41)

Regolazione del limitatore di erogazione d'acqua calda. Un limitatore di erogazione di acqua calda in combinazione con le caldaie istantanee non è consigliabile.



Manutenzione (vedi pagg. 56)

La valvola di non ritorno deve essere controllata regolarmente come da EN 806-5, secondo le normative nazionali e regionali (almeno una volta all'anno).



Ingombri (vedi pagg. 42)



Diagramma flusso (vedi pagg. 42)



Parti di ricambio (vedi pagg. 48)

XXX = Trattamento

000 = Cromato

670 = Matt Black

800 = Stainless Steel Optic

Accessori speciali

(non contenuto nel volume di fornitura)



prolunga #43333000 (vedi pagg. 47)



Pulitura (vedi pagg. 56)



Procedura (vedi pagg. 50)

Hansgrohe raccomanda, di mattina oppure dopo lunghi tempi di stagnazione, di non utilizzare il primo mezzo litro come acqua potabile.



Segno di verifica (vedi pagg. 50)

Problema	Possibile causa	Rimedio
SatinFlow troppo poco / poca acqua	- Diffusori e/o limitatori di flusso sporchi / calcificati	- Smontare e pulire i diffusori e i limitatori di flusso.
L'inversione a SatinFlow è bloccata	- Il pomello inversore è sporco	- Rimuovere e pulire il pomello inversore
Miscelatore gocciola	- Cartuccia difettosa	- Sostituire la cartuccia
Troppo poca acqua dall'erogatore estraibile	- Dispositivo antiriflusso nel raccordo del tubo flessibile e regolatore di getto calcificati / sporchi	- Pulire il dispositivo antiriflusso e il regolatore di getto
Perdita di acqua al set di fissaggio	- I raccordi dei flessibili avvitati male nel corpo incasso	- Avvitare i raccordi flessibili a mano
Lunghezza estraibile del tubo flessibile troppo corta (minore di 500 mm)	- Il peso del flessibile è montato nella posizione sbagliata	- Montare il peso del flessibile in base alle istruzioni di montaggio



Indicaciones de seguridad

- ⚠ Durante el montaje deben utilizarse guantes para evitar heridas por aplastamiento o corte.
- ⚠ Grandes diferencias de presión en servicio entre agua fría y agua caliente deben equilibrarse.

Indicaciones para el montaje

- Antes del montaje se debe examinar el producto contra daños de transporte. Después de la instalación no se reconoce ningún daño de transporte o de superficie.
- Los conductos y la grifería deben montarse, lavarse y comprobarse según las normas vigentes.
- Es obligatorio el cumplimiento de las directrices de instalación vigentes en el país respectivo.

Datos técnicos

Presión en servicio:	max. 1 MPa
Presión recomendada en servicio:	0,1 - 0,5 MPa
Presión de prueba:	1,6 MPa (1 MPa = 10 bar = 147 PSI)
Temperatura del agua caliente:	max. 70 °C
Temp. recomendada del agua caliente:	65 °C
Desinfección térmica:	max. 70 °C / 4 min

El producto ha sido concebido exclusivamente para agua potable.

Descripción de símbolos



No utilizar silicona que contiene ácido acético!



Ajuste (ver página 41)

Ajuste del límite de agua caliente. En combinación con calentadores continuos no es recomendable utilizar un bloqueo de agua caliente.



Mantenimiento (ver página 56)

Las válvulas anti-retorno tienen que ser controladas regularmente según la norma EN 806-5, en acuerdo con las regulaciones nacionales o regionales (una vez al año, por lo menos).



Dimensiones (ver página 42)



Diagrama de circulación (ver página 42)



Repuestos (ver página 48)

XXX = Acabados

000 = Cromado

670 = Matt Black

800 = Stainless Steel Optic

Opcional (no incluido en el suministro)



Prolongación #43333000 (ver página 47)



Limpiar (ver página 56)



Manejo (ver página 50)

Hansgrohe recomienda no utilizar el primer medio litro como agua potable por las mañanas o tras un largo periodo de inactividad.



Marca de verificación (ver página 50)

Problema	Causa	Solución
SatinFlow muy bajo/ cantidad de agua muy baja	- Boquillas y/o limitador de flujo sucios/con sedimentos de cal	- Desmontar y limpiar las boquillas y el limitador de flujo.
El cambio a StainFlow está atorado	- Botón de cambio sucio	- Retirar y limpiar el botón de cambio
Grifo pierde agua	- cartucho dañado	- cambiar el cartucho
Cantidad de agua muy baja en la salida de extracción	- Válvula de retención en la conexión de la manguera y el regulador de chorro llena de cal/sucia	- Limpiar la válvula de retención y el regulador de chorro
Pérdida de agua en el set de fijación	- Conexión flexible mal atornillada al cuerpo del caño.	- Apretar a mano la conexión flexible
Longitud de extensión de la manguera demasiado corta (menor a 500 mm)	- Pesa de manguera montada en posición falsa	- Montar la pesa de la manguera según las instrucciones de montaje





Veiligheidsinstructies

- △ Bij de montage moeten ter voorkoming van knel- en snijwonden handschoenen worden gedragen.
- △ Grote drukverschillen tussen de koud- en warmwater-toevoer dienen vermeden te worden.

Montage-instructies

- Vóór de montage moet het product gecontroleerd worden op transportschade. Na de inbouw wordt geen transport- of oppervlakteschade meer aanvaard.
- De leidingen en armaturen moeten gemonteerd, gespoeld en gecontroleerd worden volgens de geldige normen.
- De in de overeenkomstige landen geldende installatierichtlijnen moeten nageleefd worden.

Technische gegevens

Werkdruk: max. max. 1 MPa
 Aanbevolen werkdruk: 0,1 - 0,5 MPa
 Getest bij: 1,6 MPa
 (1 MPa = 10 bar = 147 PSI)

Temperatuur warm water: max. 70°C
 Aanbevolen warm water temp.: 65°C
 Thermische desinfectie: max. 70°C / 4 min

Het product is uitsluitend ontworpen voor drinkwater!

Symboolbeschrijving



Gebruik geen zuurhoudende silicone!



Instellen (zie blz. 41)

Instellen van de warmwaterbegrenzing. In combinatie met een doorstromer is een warmwaterblokkering niet aanbevelenswaardig.



Onderhoud (zie blz. 56)

Keerkleppen moeten volgens EN 806-5 regelmatig en volgens plaatselijk geldende eisen op het functioneren gecontroleerd worden. (Tenminste een keer per jaar)



Maten (zie blz. 42)



Doorstroomdiagram (zie blz. 42)



Service onderdelen (zie blz. 48)

XXX = Kleuren
 000 = Verchroomd
 670 = Matt Black
 800 = Stainless Steel Optic

Toebehoren

(behoort niet tot het leveringspakket)



Verlengstuk #43333000 (zie blz. 47)



Reinigen (zie blz. 56)



Bediening (zie blz. 50)

Hansgrohe raadt aan om 's morgens na langere stagnatietijden de eerste halve liter niet als drinkwater te gebruiken.



Keurmerk (zie blz. 50)

Storing	Oorzaak	Oplossing
SatinFlow te klein / weinig water	- Sproeiers en / of debietbegrenzer vervuild / verklakt	- Sproeiers en debietbegrenzer demonteren en reinigen.
Omschakeling naar SatinFlow klem	- Omschakelknop vervuild	- Omschakelknop verwijderen en reinigen
Mengkraan lekt	- Kardoes defect	- Kardoes uitwisselen
Te weinig water aan de uittrekit-loop	- Terugslagklep in de slangaansluiting en de straalregelaar verkalkt / vervuild	- Terugslagklep en straalregelaar reinigen
Lekkage op montageschacht	- Aansluitslangen niet geheel in kraanhuis vastgedraaid	- Aansluitslangen handvast aandraaien
Uittrek lengte van de slang te kort (kleiner dan 500 mm)	- Slanggewicht onjuiste positie gemonteerd	- Slanggewicht aan de hand van de montagehandleiding monteren



Sikkerhedsanvisninger

- △ Ved monteringen skal der bruges handsker for at undgå kvæstelser og snitsår.
- △ Større trykforskel mellem koldt og varmt vand bør udjævnes.

Monteringsanvisninger

- Før monteringen skal produktet kontrolleres for transportskader. Efter monteringen godkendes transportskader eller skader på overfladen ikke længere.
- Ledningerne og armaturerne skal monteres, skylles og kontrolleres iht. de gældende standarder.
- Installationsbestemmelserne, der gælder i det enkelte land, skal overholdes.

Tekniske data

Driftstryk:	max. 1 MPa
Anbefalet driftstryk:	0,1 - 0,5 MPa
Prøvetryk:	1,6 MPa (1 MPa = 10 bar = 147 PSI)
Varmtvandstemperatur:	max. 70 °C
Anbefalet varmtvandstemperatur:	65 °C
Termisk desinfektion:	max. 70 °C / 4 min
Produktet er udelukkende beregnet til drikkevand!	

Symbolbeskrivelse



Der må ikke benyttes eddikesyreholdig silikone!



Forindstilling (se s. 41)

Indstilling af varmvandsbegrænsningen. I forbindelse med gennemstrømningsvandvarmere anbefaler vi ikke en varmvandsspærre.



Service (se s. 56)

Ifølge EN 806-5 skal gennemstrømningsbegrænsere i overensstemmelse med nationale regler afprøves regelmæssigt (mindst en gang om året).



Målene (se s. 42)



Gennemstrømningsdiagram (se s. 42)



Reserve dele (se s. 48)

XXX = Overflade

000 = Krom

670 = Matt Black

800 = Stainless Steel Optic

Specialtilbehør (ikke med i leveringsomfang)



Forlængersæt #43333000 (se s. 47)



Rengøring (se s. 56)



Brugsanvisning (se s. 50)

Hansgrohe anbefaler at den første halve liter om morgenen eller efter længere stagneringstider ikke anvendes som drikkevand.



Godkendelse (se s. 50)

Fejl

Årsag

Hjælp

SatinFlow for lavt / lidt vand	- Dyser og / eller gennemstrømningsbegrænsere tilsmudset / kalket til	- Afmonter og rengør gennemstrømningsbegrænsere.
Omstilling til SatinFlow fastklæmt	- Omstillingsknap tilsmudset	- Fjern og rengør omstillingsknappen
Armaturet drypper	- Defekt kartusche	- Udskift kartusche
For lidt vand ved udrækningsudløbet	- Kontraventilen og strålerregulatoren kalket til / tilsmudset	- Rengør kontraventilen og strålerregulatoren
Armaturet er utæt ved befæstelsesdelene	- Tilslutningsslangerne er ikke skruet korrekt op i armaturet.	- Med håndkraft skures tilslutningsslangen strammere på.
Udvidelseslængde slange for kort (under 500 mm)	- Slangelod monteret på forkert position	- Monter slangelod i henhold til monteringsvejledningen





Avisos de segurança

- ⚠ Durante a montagem devem ser utilizadas luvas de protecção, de modo a evitar ferimentos resultantes de entalamentos e de cortes.
- ⚠ Grandes diferenças entre as pressões das águas quente e fria devem ser compensadas.

Avisos de montagem

- Antes da montagem deve-se controlar o produto relativamente a danos de transporte. Após a montagem não são aceites quaisquer danos de transporte ou de superfície.
- As tubagens e a torneira têm que ser montadas, enxaguadas e verificadas de acordo com as normas em vigor.
- A prescrições de instalação válidas nos respetivos países devem ser respeitadas.

Dados Técnicos

Pressão de funcionamento: max. 1 MPa
 Pressão de func. recomendada: 0,1 - 0,5 MPa
 Pressão testada: 1,6 MPa
 (1 MPa = 10 bar = 147 PSI)

Temperatura da água quente: max. 70 °C
 Temp. água quente recomendada: 65 °C
 Desinfecção térmica: max. 70 °C / 4 min
 Este produto foi única e exclusivamente concebido para água potável!

Descrição do símbolo



Não utilizar silicone que contenha ácido acético!



Afinação (ver página 41)

Ajuste do limitador de água quente. Em combinação com um esquentador, não é recomendável o uso de um bloqueio de água quente.



Manutenção (ver página 56)

As válvulas anti-retorno devem ser verificadas regularmente de acordo com a EN 806-5 segundo os regulamentos nacionais ou regionais (pelo menos uma vez por ano).



Medidas (ver página 42)



Fluxograma (ver página 42)



Peças de substituição

(ver página 48)

XXX = Acabamentos

000 = Cromado

670 = Matt Black

800 = Stainless Steel Optic

Acessórios especiais

(não incluído no volume de fornecimento)



Crescente #43333000 (ver página 47)



Limpeza (ver página 56)



Funcionamento (ver página 50)

A Hansgrohe recomenda a não utilização do primeiro meio litro de água, de manhã ou após longas paragens, para fins de consumo.



Marca de controlo (ver página 50)

Falha	Causa	Solução
SatinFlow muito fraco / pouca água	- Bocais e / ou redutor de caudal com sujidade / calcificados	- Desmontar e limpar os bocais e o redutor de caudal.
Inversão para SatinFlow encravada	- Botão inversor com sujidade	- Remover o botão inversor e limpar
Misturadora a pingar	- Cartucho defeituoso	- Substituir o cartucho
Pouca água na bica extensível	- Válvula antirretorno na ligação do tubo e regulador do jato calcificados / com sujidade	- Limpar a válvula antirretorno e o regulador do jato
Perde água pela base roscada	- Tubos de ligação não estão completamente enroscados	- Apertar os tubos de ligação à mão
Comprimento de extração do tubo muito curto (inferior a 500 mm)	- Peso do tubo montado na posição incorreta	- Montar o peso da mangueira de acordo com as instruções de montagem



Wskazówki bezpieczeństwa

- △ Aby uniknąć zranień na skutek zgniecenia lub przecięcia, podczas montażu należy nosić rękawice ochronne.
- △ Znaczne różnice ciśnień na dopływach ciepłej i zimnej wody muszą zostać wyrównane.

Wskazówki montażowe

- Przed montażem należy skontrolować produkt pod kątem szkód transportowych. Po montażu nie widać żadnych szkód transportowych ani szkód na powierzchni.
- Przewody i armatura muszą być montowane, płukane i kontrolowane według obowiązujących norm.
- Należy przestrzegać wytycznych instalacyjnych obowiązujących w danym kraju.

Dane techniczne

Ciśnienie robocze:	maks. 1 MPa
Zalecane ciśnienie robocze:	0,1 - 0,5 MPa
Ciśnienie próbne:	1,6 MPa (1 MPa = 10 bary = 147 PSI)
Temperatura wody gorącej:	maks. 70°C
Zalecana temperatura wody gorącej:	65°C
Dezynfekcja termiczna:	maks. 70°C / 4 min
Produkt przeznaczony wyłącznie do wody pitnej!	

Opis symbolu



Nie stosować silikonów zawierających kwas octowy!



Ustawianie (patrz strona 41)

Ustawianie ogranicznika ciepłej wody. Używanie ogranicznika temperatury wody w połączeniu z

przepływowym podgrzewaczem wody nie jest zalecane.



Konserwacja (patrz strona 56)

Zgodnie z normą EN 806-5, krajowymi i miejscowymi przepisami, działanie zabezpieczeń przed przepływem zwrótnym musi być kontrolowane (przynajmniej raz w roku).



Wymiary (patrz strona 42)



Schemat przepływu (patrz strona 42)



Części serwisowe (patrz strona 48)

XXX = Kody kolorów
000 = Chrom
670 = Matt Black
800 = Stainless Steel Optic

Wyposażenie specjalne

(Nie jest częścią dostawy)



Przedłużka #43333000 (patrz strona 47)



Czyszczenie (patrz strona 56)



Obsługa (patrz strona 50)

Hansgrohe zaleca, by z rana lub po dłuższym czasie niekorzystania, pierwsze pół litra wody nie używać jako wody pitnej.



Znak jakości (patrz strona 50)

Usterka	Przyczyna	Pomoc
SatinFlow za mały / mało wody	- Dysze i / lub ogranicznik przepływu zabrudzone / pokryte kamieniem	- Zdemontować i wyczyścić dysze i ogranicznik przepływu.
Przestawianie na SatinFlow zacina się	- Zabrudzony przycisk przełączania	- Usunąć przycisk i wyczyścić
Armatura cieknie	- Uszkodzony wkład	- Wymiana wkładu
Za mało wody na wyciąganej końcówce	- Zawór zwrótny w przyłączu węża i regulator strumienia pokryte kamieniem/zabrudzone	- Wyczyścić zawór zwrótny i regulator strumienia
Wyciek wody przy mocowaniu od dołu	- Zbyt słabo wkręcone wężyki w korpus	- Dokręcić wężyki
Długość węża do wyciągnięcia za krótka (mniej niż 500 mm)	- Obciążnik wodny zamontowany w złym miejscu	- Obciążnik wodny założyć zgodnie z instrukcją montażu





Bezpečnostní pokyny

- △ Pro zabránění řezným zraněním a pohmožděninám je nutné při montáži nosit rukavice.
- △ Je nutné vyrovnat velké rozdíly tlaku mezi přípoji studené a teplé vody.

Pokyny k montáži

- Před montáží je třeba produkt zkontrolovat, zda nebyl při transportu poškozen. Po zabudování nebudou uznány žádné škody způsobené transportem nebo poškození povrchu.
- Vedení a armatura musí být namontovány, propláchnuty a otestovány podle platných norem.
- Je třeba dodržovat montážní pravidla platné v dané zemi.

Technické údaje

Provozní tlak: max. 1 MPa
 Doporučený provozní tlak: 0,1 - 0,5 MPa
 Zkušební tlak: 1,6 MPa
 (1 MPa = 10 bar = 147 PSI)

Teplota horké vody: max. 70 °C
 Doporučená teplota horké vody: 65 °C
 Tepelná desinfekce: max. 70 °C / 4 min

Výrobky Hansgrohe jsou vhodné pro přímý kontakt s pitnou vodou.

Popis symbolů



Nepoužívat silikon s obsahem kyseliny octové!



Nastavení (viz strana 41)

Nastavení omezovače teplé vody. Ve spojení s průtokovým ohříváčem se použítí uzávěru teplé vody nedoporučuje.

Porucha	Příčina	Odstranění
SatinFlow příliš nízký / málo vody	- Trysky a / nebo omezovač průtoku znečištěný / ucpaný vodním kamenem	- Demontovat a vyčistit trysky a omezovač průtoku.
Přepnutí na SatinFlow se zaseklo	- Přepínací hlava znečištěna	- Odstranit a vyčistit přepínací hlavu
Armatura odkapává	- Kartuše je vadná	- Kartuši vyměnit
Příliš málo vody na vytahovacím výstupu	- Omezovač zpětného průtoku v hadicové přípojce a regulátoru postřiku je zanesený vodním kamenem / znečištěný	- Vyčistit omezovač zpětného průtoku a regulátor postřiku
výstup vody na upevňovacím násadci	- přípojovací hadice nejsou dostatečně zašroubovány do tělesa	- přípojovací hadice utáhnout rukou
Délka vytažení hadice příliš krátká (menší než 500 mm)	- Závaží hadice přimontováno v chybné pozici	- Závaží hadice přimontujte dle návodu k montáži



Údržba (viz strana 56)

U zpětných ventilů se musí podle EN 806-5 v souladu s národními nebo regionálními předpisy testovat jejich funkčnost (alespoň jednou ročně).



Rozměry (viz strana 42)



Diagram průtoku (viz strana 42)



Servisní díly (viz strana 48)

XXX = Kód povrchové úpravy
 000 = Chrom
 670 = Matt Black
 800 = Stainless Steel Optic

Zvláštní příslušenství

(není součástí dodávky)



prodloužení #43333000 (viz strana 47)



Čištění (viz strana 56)



Ovládání (viz strana 50)

Hansgrohe doporučuje ráno nebo po delších přestávkách nepoužívat prvního půl litru jako pitnou vodu.



Zkušební značka (viz strana 50)



Bezpečnostné pokyny

- △ Pri montáži musíte nosiť rukavice, aby ste predišli pomliaždeninám a rezným poraneniam.
- △ Veľké rozdiely v tlaku medzi prípojkami studenej a teplej vody musia byť vyrovnané.

Pokyny pre montáž

- Pred montážou musíte produkt skontrolovať, či nebol počas transportu poškodený. Po zabudovaní nebudú uznané žiadne škody spôsobené transportom alebo poškodenia povrchu.
- Potrubia a vybavenie musia byť namontované, prepláchnuté a vybavené v platnom normami.
- Je potrebné dodržiavať smernice o inštalácii, ktoré sú práve teraz platné v krajinách.

Technické údaje

Prevádzkový tlak:	max. 1 MPa
Doporučený prevádzkový tlak:	0,1 - 0,5 MPa
Skúšobný tlak:	1,6 MPa
	(1 MPa = 10 bar = 147 PSI)
Teplota teplej vody:	max. 70 °C
Doporučená teplota teplej vody:	65 °C
Termická dezinfekcia:	max. 70 °C / 4 min

Výrobok je koncipovaný výhradne pre pitnú vodu!

Popis symbolov



Nepoužívať silikón s obsahom kyseliny octovej!



Nastavenie (vid' strana 41)

Nastavenie obmedzenia teplej vody. V spojení s prietokovými ohrievačmi sa neodporúča použitie obmedzovača teplej vody.

Porucha	Príčina	Pomoc
SatinFlow príliš nízky / málo vody	- Dýzy a / alebo obmedzovač prietoku znečistené(-ý) / zanesené(-ý) vodným kameňom	- Demontujte a vyčistite dýzy a obmedzovač prietoku.
Prestavenie na SatinFlow sa zasekáva	- Prestavovací gombík je znečistený	- Odstráňte a vyčistite prestavovací gombík
Z armatúry kvapká voda	- Kartuša je poškodená	- Vymeniť kartušu
Príliš málo vody na vyťahovacom výtoku	- Zabraňovač spätnému toku v hadicovej prípojke a regulátor prúdu zanesený vodným kameňom / znečistený	- Vyčistite zabraňovač spätnému toku a regulátor prúdu
Uhajanie vode ob pritrídilnem nastavku	- Hadice pripojenia nie sú celkom zaskrutkované do základného telesa	- Hadice pripojenia dotiahnuť ručne
Dĺžka vytiahnutia hadice je príliš krátka (menšia ako 500 mm)	- Závažie na hadicu namontované v nesprávnej pozícii	- Závažie na hadicu namontujte podľa návodu na montáž



Údržba (vid' strana 56)

Pri spätných ventiloch sa musí podľa EN 806-5 v súlade s národnými alebo regionálnymi predpismi testovať ich funkčnosť (aspoň raz ročne).



Rozmery (vid' strana 42)



Diagram prietoku (vid' strana 42)



Servisné diely (vid' strana 48)

XXX = Farebné označenie

000 = Chróm

670 = Matt Black

800 = Stainless Steel Optic

Zvláštne príslušenstvo

(nie je súčasťou dodávky)



Predĺženie #43333000 (vid' strana 47)



Čistenie (vid' strana 56)



Obsluha (vid' strana 50)

Hansgrohe odporúča ráno a po dlhších dobách odstavky nepoužiť prvého pol litra vody ako pitnú vodu.



Osvedčenie o skúške (vid' strana 50)





安全技巧

- △ 装配时为避免挤压和切割受伤，必须戴上手套。
- △ 冷热水管间过大的压力差必须予以平衡。

安装提示

- 安装前必须检查产品是否受到运输损害。安装后将不认可运输损害或表面损伤。
- 管道和阀门必须根据通用标准进行安装、冲洗和检查。
- 请遵守当地国家现行的安装规定。

技术参数

工作压力:	最大 1 MPa
推荐工作压力:	0,1 - 0,5 MPa
测试压强:	1,6 MPa (1 MPa = 10 bar = 147 PSI)
热水温度:	最大 70°C
推荐热水温度:	65°C
热力消毒:	最大 70°C / 4 分钟

该产品专为饮用水设计！

符号说明



请勿使用含有乙酸的硅胶！



调节 (参见第页 41)

热水温度调节。如果使用即热式喷头，则不建议安装热水阀门。



保养 (参见第页 56)

单向阀必须在符合国家或当地的法律的情况下按照EN 806-5定期检查 (至少一年一次)。



大小 (参见第页 42)



流量示意图 (参见第页 42)



备用零件 (参见第页 48)

XXX = 颜色代码
000 = 镀铬
670 = Matt Black
800 = Stainless Steel Optic

选装附件 (不在供货范围内)



加长件 #43333000 (参见第页 47)



清洗 (参见第页 56)



操作 (参见第页 50)

汉斯格雅建议，清晨或在水流长时间停滞后，前半升水不作饮用水使用。



检验标记 (参见第页 50)

问题	原因	补救
SatinFlow 流量过低 / 水量太少	- 喷嘴及/或流量限制器有污垢/水垢	- 拆下喷嘴和流量限制器并进行清洁。
SatinFlow 上的转换装置卡死	- 转换按钮有污垢	- 拆下转换按钮并进行清洁
龙头滴水	- 阀芯损坏	- 更换阀芯
抽拉式水嘴出水过少	- 软管接口和射束调节器上的止回阀有水垢/污垢	- 清洁止回阀和射束调节器
水从螺纹底座中流出	- 连接软管没有完全旋入基体	- 用手拧紧连接软管
软管的可抽拉长度过短 (小于 500mm)	- 软管配重块安装位置错误	- 按照安装说明书安装软管配重块

安装 (参见第页 33)



Указания по технике безопасности

- Во время монтажа следует надеть перчатки во избежание прищемления и порезов.
- донного клапа. Перед установкой смесителя необходимо регулировочными кранами выровнять давление холодной и горячей воды при помощи вентилей регулирующих подачу воды в квартиру.

Указания по монтажу

- Перед монтажом следует проверить изделие на предмет повреждений при перевозке. После монтажа претензии о возмещении ущерба за повреждения при перевозке или повреждения поверхностей не принимаются.
- Трубы и арматура должны быть установлены, промыты и проверены в соответствии с действующими нормами.
- Необходимо соблюдать требования по монтажу, действующие в соответствующих странах.

Технические данные

Рабочее давление: не более, 1 МПа
 Рекомендуемое рабочее давление: 0,1 - 0,5 МПа
 Давление: 1,6 МПа
 (1 МПа = 10 bar = 147 PSI)
 Температура горячей воды: не более, 70°C
 Рекомендуемая темп. гор. воды: 65°C
 Термическая дезинфекция: не более, 70°C / 4 мин
 Изделие предназначено исключительно для питьевой воды!

Описание символов



Не применяйте силикон, содержащий уксусную кислоту.



Подгонка (см. стр. 41)

Регулировка ограничителя горячей воды. В сочетании с проточными нагревателями не рекомендуется использовать блокировку воды.



Техническое обслуживание (см. стр. 56)

Защита обратного тока должна регулярно проверяться (минимум один раз в год) по стандарту EN 806-5 или в соответствии с национальными или региональными нормативами



Размеры (см. стр. 42)



Схема потока (см. стр. 42)



Комплект (см. стр. 48)

XXX = Цветная кодировка
 000 = Хром
 670 = Matt Black
 800 = Stainless Steel Optic

Специальные принадлежности

(не включено в объем поставки!)



Удлинение #43333000 (см. стр. 47)



Очистка (см. стр. 56)



Эксплуатация (см. стр. 50)

Hansgrohe рекомендует по утрам либо после длительного перерыва в использовании не использовать первые поллитра воды для питья.



Знак технического контроля (см. стр. 50)

Неисправность	Причина	Устранение неисправности
SatinFlow слишком слаб / мало воды	- Форсунки и/или ограничитель потока засорены / покрылись известью	- Демонтировать и почистить форсунки и ограничитель потока.
Переключение на SatinFlow не срабатывает	- Кнопка переключения засорилась	- Снять кнопку переключения и почистить
Арматура протекает	- Картридж неисправен	- Замените картридж
Слишком мало воды в вытяжном сливном устройстве	- Прерыватель обратного потока в соединении шланга и регулятор струи покрылись известью / засорены	- Почистить прерыватель обратного потока и регулятор струи
Выход воды у основания крепления	- Шланги подключения не полностью завернуты в корпус	- Затяните шланги подключения вручную
Слишком маленькая длина вытяжного шланга (менее 500 мм)	- Утяжелитель шланга монтирован в неподходящем месте	- Утяжелитель шланга монтировать в соответствии с монтажной инструкцией





Turvallisuusohjeet

- △ Asennuksessa on käytettävä käsiineitä puristumien ja viiltojen aiheuttamien tapaturmien estämiseksi.
- △ Suuret paine-erot kylmä- ja kuumavesiliitäntöjen välillä on tasattava.

Asennusohjeet

- Ennen asennusta on tarkastettava tuotteen mahdolliset kuljetusvahingot. Asennuksen jälkeen kuljetus- ja pintavaurioita ei hyväksytä.
- Putket ja hana on asennettava, huuhdeltava ja tarkastettava voimassa olevien standardien mukaisesti.
- Jokaisessa maassa on noudatettava siellä päteviä asennusohjeita.

Tekniset tiedot

Käyttöpaine:	maks. 1 MPa
Suosittelut käyttöpaine:	0,1 - 0,5 MPa
Koestuspaine:	1,6 MPa (1 MPa = 10 bar = 147 PSI)
Kuuman veden lämpötila:	maks. 70 °C
Kuuman veden suosituslämpötila:	65 °C
Lämpödesinfektio:	maks. 70 °C / 4 min

Tuote on suunniteltu käytettäväksi ainoastaan juomaveden kanssa!

Merkin kuvaus



Älä käytä etikkahappopitoista silikonia!



Säätö (katso sivu 41)

Lämpötilan rajoittimen säätäminen. Emme suosittele käyttämään lämpötilan rajoitinta vedenlämmittimen (läpivirtauskuumennin) yhteydessä.



Huolto (katso sivu 56)

Vastaventiilien toiminta on tarkastettava säännöllisesti paikallisten ja kansallisten määräysten mukaisesti (EN 806-5, vähintään kerran vuodessa).



Mitat (katso sivu 42)



Virtausdiagrammi (katso sivu 42)



Varaosat (katso sivu 48)

XXX = Värikoodaus

000 = Kromi

670 = Matt Black

800 = Stainless Steel Optic

Erityisvaruste (ei kuulu toimitukseen)



Pidennys #43333000 (katso sivu 47)



Puhdistus (katso sivu 56)



Käyttö (katso sivu 50)

Hansgrohe suosittelee, että ensimmäistä puolta litraa ei käytetä juomavetenä aamuisin eikä silloin, kun laitetta ei ole käytetty pitkään aikaan.



Koestusmerkki (katso sivu 50)

Häiriö

Syy

Toimenpide

SatinFlow liian pieni / vähän vettä	- Suuttimet ja/tai läpivirtausrajoittimet likaisia/kalkkeutuneita	- Irrota ja puhdista suuttimet ja läpivirtausrajoittimet
Vaihto SatinFlow jumissa	- Vaihtonuppi likainen	- Poista ja puhdista vaihtonuppi
Hanasta tippuu vettä	- Patruuna rikki	- Vaihda patruuna
Liian vähän vettä ulos vedettävässä juoksuputkessa	- Paluuvirtausrajoitin letkuliitinnässä ja suihkunsäätimessä kalkkeutunut/likainen	- Puhdista paluuvirtausrajoitin ja suihkunsäädin
Vettä valuu kiinnityskauluksesta	- Liitosletkut eivät ole kierretty kiinni perusrunkoon pohjaan asti	- Kierrä liitosletkut kiinni käsikireyteen
Letkun ulosvetopituus liian lyhyt (alle 500 mm)	- Letkupaino asennettu väärään kohtaan	- Asenna letkupaino asennusohjeen mukaisesti



Säkerhetsanvisningar

- △ Handskar ska bäras under monteringsarbetet så att man kan undvika kläm- och skärskador.
- △ Stora tryckskillnader mellan anslutningarna för varmt och kallt vatten måste utjämnas.

Monteringsanvisningar

- Det måste undersökas om produkten har transportskador innan den monteras. Efter monteringen accepteras inga transport- eller ytskiktsskador.
- Ledningarna och blandaren måste monteras, spolas igenom och kontrolleras enligt de gällande normerna.
- De installationsriktlinjer som gäller i länderna ska följas.

Tekniska data

Driftstryck:	max. 1 MPa
Rek. driftstryck:	0,1 - 0,5 MPa
Tryck vid provtryckning:	1,6 MPa (1 MPa = 10 bar = 147 PSI)
Varmvattentemperatur:	max. 70 °C
Rek. varmvattentemp.:	65 °C
Termisk desinfektion:	max. 70 °C / 4 min

Produkten är enbart avsedd för dricksvatten!

Symbolförklaring



Använd inte silikon som innehåller ättiksyra!



Justering (se sidan 41)

Ställa in varmvattenregleringen. Tillsammans med varmvattenberedare rekommenderas inte en varmvattenspär.



Skötsel (se sidan 56)

Backventilens funktion måste kontrolleras regelbundet enligt nationella eller regionala bestämmelser i enlighet med EN 806-5 (minst en gång per år).



Måtten (se sidan 42)



Flödesschema (se sidan 42)



Reservdelar (se sidan 48)

XXX = Färgkodning
000 = Krom
670 = Matt Black
800 = Stainless Steel Optic

Specialtillbehör (medföljer ej leveransen)



Förlängning #43333000 (se sidan 47)



Rengöring (se sidan 56)



Hantering (se sidan 50)

Hansgrohe rekommenderar att den första halvlitern inte används som dricksvatten på morgonen eller efter längre perioder utan användning.



Testsgill (se sidan 50)

Störning

Orsak

Åtgärd

SatinFlow för låg / lite vatten	- Munstycken och/eller flödeskontroll nedsmutsad/täckt av kalk	- Ta av munstycken och flödeskontroll och rengör.
Omställning till SatinFlow fastklämd	- Omställningsknappen nedsmutsad	- Ta av omställningsknappen och rengör
Blandare droppar	- Patron defekt	- Byt ut patron
För lite vatten i utdragsutloppet	- Backventilen i slanganslutningen och strålregulatorn täckt av kalk/nedsmutsad	- Rengör backventil och strålregulatorn
Vatten kommer ut vid monteringsstaget	- Anslutningsslangar inte helt inskruvade i grundkonstruktionen	- Drag fast anslutningsslangar för hand.
Slangens utdragningslängd för kort (mindre än 500 mm)	- Slangviket monterad vid felaktig position	- Montera slangvikten enligt monteringsbeskrivningen



Saugumo technikos nurodymai

⚠️ Apsaugai nuo užspaudimo ir įsijovimo montavimo metu mūvėkite pirštines.

⚠️ Turi būti išlyginti šalto ir karšto slėgio nelygumai.

Montavimo instrukcija

- Prieš montuojant būtina patikrinti, ar gaminys nebuvo pažeistas transportavimo metu. Sumontavus pretenzijos dėl transportavimo ir paviršiaus pažeidimų nepriimamos.
- Vamzdžiai ir sujungimai turi būti montuojami, plaunami ir tikrinami pagal galiojančias normas.
- Laikykites atitinkamoje šalyje galiojančių direktyvų dėl įrengimo.

Techniniai duomenys

Darbinis slėgis: ne daugiau kaip 1 MPa

Rekomenduojamas slėgis: 0,1 - 0,5 MPa

Bandomasis slėgis: 1,6 MPa

(1 MPa = 10 barų = 147 PSI)

Karšto vandens temperatūra: ne daugiau kaip 70°C

Rekomenduojama karšto vandens temperatūra: 65°C

Terminis dezinfekavimas: ne daugiau kaip 70°C / 4 min

Produktas skirtas tik geriamajam vandeniui!

Simbolio aprašymas



Nenaudokite silikono, kurio sudėtyje yra acto rūgšties!



Reguliavimas (žr. psl. 41)

Karšto vandens ribojimas. Kartu su cirkuliaciniais šildytuvais nerekomenduojama naudoti karšto vandens blokavimo įtaisų.



Techninis aptarnavimas

(žr. psl. 56)

Atbulinio vožtuvo apsauga privalo būti tikrinama reguliariai (mažiausiai kartą per metus) pagal EN 806-5 arba pagal galiojančias nacionalines arba regionines normas.



Išmatavimai (žr. psl. 42)



Pralaidumo diagrama (žr. psl. 42)



Atsarginės dalys (žr. psl. 48)

XXX = Spalvos

000 = Chrom

670 = Matt Black

800 = Stainless Steel Optic

Specialūs priedai (nėra pridedama)



Ilgiklis #43333000 (žr. psl. 47)



Valymas (žr. psl. 56)



Eksplotacija (žr. psl. 50)

Naudojant po ilgesnės pertraukos, „Hansgrohe“ rekomenduoja pirmo pusės litro vandens nevartoti kaip geriamojo.



Bandymo pažyma (žr. psl. 50)

Gedimas	Priežastis	Priemonė
„SatinFlow“ per mažai / per daug vandens	- Užsiteršę / užkalkėję purškikliai ir / arba vandens srauto ribotuvai	- Išmontuoti ir išvalyti purškiklius ir srauto ribotuvus.
Stringa perjungiklis į „SatinFlow“	- Užsiteršęs perjungimo mygtukas	- Išimti ir išvalyti perjungimo mygtuką
Maišytuvus praleidžia vandenį	- Kasetė pažeista	- Pakeisti kasetę
Per mažai vandens ištraukiamoje žarnosje	- Užkalkėję / užsiteršę atbulinis vožtuvas žarnos jungtyje ir srauto reguliatorius	- Išvalykite atbulinį vožtuvą ir srauto reguliatorių
Prateka vanduo per tvirtinimo kotą	- Prijungimo žarnos nepilnai įsuktos į korpusą	- Prijungimo žarnas prisukti ranka
Per mažas žarnos ištraukimo ilgis (mažiau nei 500 mm)	- Pripučiamas svarmuo primontuotas netinkamoje vietoje	- Pripučiamą svarmenį primontuokite tinkamoje vietoje

**Sigurnosne upute**

- △ Prilikom montaže se radi sprječavanja prignječenja i posjekotina moraju nositi rukavice.
- △ Velika razlika u pritisku između vruće i hladne vode mora biti izbalansirana.

Upute za montažu

- Prije montaže mora se provjeriti je li proizvod oštećen prilikom transporta. Nakon ugradnje se ne priznaju nikakve reklamacije koje se odnose na površinska i transportna oštećenja.
- Cijevi i armatura moraju biti postavljeni, isprani i testirani prema važećim normama.
- Obvezno se moraju uvažiti propisi o instalacijama koji vrijede u dotičnoj zemlji.

Tehnički podatci

Najveći dopušteni tlak:	tlak 1 MPa
Preporučeni tlak:	0,1 - 0,5 MPa
Probni tlak:	1,6 MPa
	(1 MPa = 10 bar = 147 PSI)
Temperatura vruće vode:	tlak 70 °C
Preporučena temperatura vruće vode:	65 °C
Termička dezinfekcija:	tlak 70 °C / 4 min
Proizvod je koncipiran isključivo za pitku vodu!	

Opis simbola

Nemojte koristiti silikon koji sadrži octenu kiselinu!

**Regulacija (pogledaj stranicu 41)**

Namještanje limitera tople vode. U kombinaciji s protočnim bojlerima nije preporučljiva primjena sustava za blokiranje dotoka tople vode.

**Održavanje (pogledaj stranicu 56)**

Ispravnost nepovratnog ventila mora se redovito provjeravati prema standardu EN 806-5 i u skladu sa važećim propisima (najmanje jednom godišnje).

**Mjere (pogledaj stranicu 42)****Dijagram protoka (pogledaj stranicu 42)****Rezervni djelovi (pogledaj stranicu 48)**

XXX = Boje
000 = Krom
670 = Matt Black
800 = Stainless Steel Optic

Posebni pribor (Nije sadržano u isporuci!)

Produljenje
#43333000 (pogledaj stranicu 47)

**Čišćenje (pogledaj stranicu 56)****Upotreba (pogledaj stranicu 50)**

Hansgrohe preporuča da ujutro ili nakon duljeg nekorištenja prvih 1/2 litre vode ne upotrebljavate za piće.

**Oznaka testiranja (pogledaj stranicu 50)**

Greška	Uzrok	Otklanjanje
SatinFlow premali protok / premalo vode	- Mlaznice i/ili limitator protoka zaprljani / s naslagama vapnenca	- Izvadite i očistite mlaznice i limitator protoka.
Preusmjerivač na SatinFlow	- Gumb za preusmjeravanje zaprljan	- Uklonite i očistite gumb za preusmjeravanje
Slavina kaplje	- Neispravan uložak	- Zamijenite uložak
Premalo vode u izvlačnom ispustu	- Nepovratni ventil u priključku crijeva i regulatoru mlaza s naslagama vapnenca	- Očistite nepovratni ventil i regulator mlaza
Voda izlazi na dijelu gdje je slavina učvršćena	- Priključna crijeva nisu potpuno učvršćena na tijelo	- Priključna crijeva učvrstite rukom
Prekratka izvlačna duljina crijeva (manje od 500 mm)	- Uteg crijeva montiran na pogrešnom mjestu	- Montirajte uteg crijeva prema uputama za montažu





Güvenlik uyarıları

- ⚠ Montaj esnasında ezilme ve kesilme gibi yaralanmaları önlemek için eldiven kullanılmalıdır.
- ⚠ Sıcak ve soğuk su bağlantıları arasında büyük basınç farklılıkları varsa, bu basınç farklılıklarının dengelenmesi gerekir.

Montaj açıklamaları

- Montaj işleminden önce ürün nakliye hasarları yönünden kontrol edilmelidir. Montaj işleminden sonra nakliye veya yüzey hasarları için sorumluluk üstlenilmemektedir.
- Boruların ve armatürün montajı, yıkanması ve kontrolü geçerli normlara göre yapılmalıdır.
- Ülkelerde geçerli kurulum yönetmeliklerine riayet edilmelidir.

Teknik bilgiler

İşletme basıncı:	azami 1 MPa
Tavsiye edilen işletme basıncı:	0,1 - 0,5 MPa
Kontrol basıncı:	1,6 MPa (1 MPa = 10 bar = 147 PSI)
Sıcak su sıcaklığı:	azami 70°C
Tavsiye edilen su ısıtı:	65°C
Termik dezenfeksiyon:	azami 70°C / 4 dak

Ürün sadece şebeke suyu için tasarlanmıştır!

Simge açıklaması



Asetik asit içeren silikon kullanmayın!



Ayarlama (bakınız sayfa 41)

Sıcak su sınırlamasının ayarlanması. Sıcak su kilidinin sürekli ısıtıcıyla kullanılması tavsiye edilmez.



Bakım (bakınız sayfa 56)

EN 806-5 ve ulusal standartlar doğrultusunda Çek valfler düzenli olarak kontrol edilmelidir. (en az yılda bir kez)



Ölçüleri (bakınız sayfa 42)



Akış diyagramı (bakınız sayfa 42)



Yedek Parçalar (bakınız sayfa 48)

XXX = Renkler

000 = Krom

670 = Matt Black

800 = Stainless Steel Optic

Özel aksesuarlar

(Teslimat kapsamına dahil değildir)



Uzatma #43333000 (bakınız sayfa 47)



Temizleme (bakınız sayfa 56)



Kullanımı (bakınız sayfa 50)

Hansgrohe sabahları uzun durgunluk süresi sonrasında ilk yarım litre suyun içme suyu olarak kullanılmamasını önerir.



Kontrol işareti (bakınız sayfa 50)

arıza	sebebi	yardım
SatinFlow çok düşük / az su	- Memeler ve / veya akış sınırlayıcı kirli / kireçli	- Memeleri ve akış sınırlayıcıyı söküp temizleyin.
SatinFlow' a değişiklik sıkışıyor	- Değiştirme düğmesi kirli	- Değiştirme düğmesini çıkarıp temizleyin
Batarya su damlatıyor	- Kartuş bozuk olabilir	- Kartuşu değiştirin
Çekme çıkışında çok az su	- Hortum bağlantısındaki ve havalandırıcıdaki geri akış önleyici kireçlenmiş / kirlenmiş	- Geri akış önleyiciyi ve havalandırıcıyı temizleyin
Sabitleme kutusundan su çıkışı	- Bağlantı hortumları ana gövdeye tamamen vidalanmamış	- Bağlantı hortumlarını elinizle sıkın
Hortumun çıkarma uzunluğu çok az (500 mm altında)	- Hortum ağırlığı yanlış konuma takıldı	- Hortum ağırlığını montaj kılavuzu uyarınca takın



Instrucțiuni de siguranță

- ⚠ La montare utilizați mănuși pentru evitarea contuziunilor și tăierii mâinilor.
- ⚠ Diferențele de presiune mari între alimentarea cu apă rece și apă caldă trebuie echilibrate.

Instrucțiuni de montare

- Înainte de instalare verificați, dacă produsul prezintă deteriorări de transport. După instalare garanția nu acoperă deteriorările de transport și cele de suprafață.
- Conductele și bateriile trebuie montate, spălate și verificate conform normelor în vigoare.
- Respectați reglementările referitoare la instalare valabile în țara respectivă.

Date tehnice

Presiune de funcționare:	max. 1 MPa
Presiune de funcționare recomandată:	0,1 - 0,5 MPa
Presiune de verificare:	1,6 MPa
	(1 MPa = 10 bar = 147 PSI)
Temperatura apei calde:	max. 70 °C
Temperatura recomandată a apei calde:	65 °C
Dezinfecție termică:	max. 70 °C / 4 min
Produsul este destinat exclusiv pentru apă potabilă.	

Descrierea simbolurilor



Nu utilizați silicon cu conținut de acid acetic!



Reglare (vezi pag. 41)

Reglarea limitatorului de apă caldă. Nu se recomandă folosirea unui limitator de apă caldă în combinație cu un boiler instant.



Întreținere (vezi pag. 56)

Supapele antiretur trebuie verificate regulat conform EN 806-5 și standardele naționale sau regionale (cel puțin o dată pe an).



Dimensiuni (vezi pag. 42)



Diagrama de debit (vezi pag. 42)



Piese de schimb (vezi pag. 48)

XXX = Coduri de culori
 000 = Crom
 670 = Matt Black
 800 = Stainless Steel Optic

Accesorii opționale

(nu este inclus în setul livrat)



Prelungitor #43333000 (vezi pag. 47)



Curățare (vezi pag. 56)



Utilizare (vezi pag. 50)

Hansgrohe vă recomandă, ca dimineața sau după perioade mai lungi de pauză să nu folosiți prima jumătate de litru de apă pentru băut.



Certificat de testare (vezi pag. 50)

Deranjament	Cauza	Măsurile de remediere
SatinFlow prea redus / puțină apă	- Duzele și / limitatoarele de debit sunt murdare / calcificate	- Demontați duzele și limitatoarele de debit și curățați-le.
Butonul de comutare pe SatinFlow se blochează	- Butonul de comutare este murdar	- Demontați și curățați butonul de comutare
Bateria picură	- Cartuș defect	- Schimbați cartușul.
Prea puțină apă la evacuarea de aspirare	- Elementul de reținere la racordul pentru furtun și regulatorul de jet sunt calcificate / murdare	- Curățați elementul de reținere și regulatorul de jet.
Scurgere de apă la șaftul de fixare.	- Furtunurile de racordare nu sunt bine înșurubate în corpul bateriei.	- Strângeți cu mâna furtunurile de racordare.
Lungimea de tracțiune a furtunului este prea redusă (sub 500 mm)	- Greutatea de furtun este montată în poziția incorectă	- Montați greutatea de furtun conform instrucțiunilor de montare



Υποδειξεις ασφαλείας

- Για να αποφύγετε τραυματισμούς κατά τη συναρμολόγηση πρέπει να φοράτε γάντια.
- Οι διαφορές της πίεσης μεταξύ της σύνδεσης κρύου και ζεστού νερού θα πρέπει να αντισταθμίζονται.

Οδηγίες συναρμολόγησης

- Πριν τη συναρμολόγηση πρέπει να εξεταστεί το προϊόν για ζημιές μεταφοράς. Μετά την εγκατάσταση δεν αναγνωρίζονται ζημιές από τη μεταφορά ή επιφανειακές ζημιές.
- Οι σωλήνες και η μπαταρία πρέπει να τοποθετηθούν σύμφωνα με τα ισχύοντα πρότυπα, να τεθούν υπό πίεση και να δοκιμαστούν.
- Θα πρέπει να τηρούνται οι οδηγίες εγκατάστασης που ισχύουν σε κάθε κράτος.

Τεχνικά Χαρακτηριστικά

Λειτουργία πίεσης:	έως 1 MPa
Συνιστώμενη λειτουργία πίεσης:	0,1 - 0,5 MPa
Πίεση ελέγχου:	1,6 MPa (1 MPa = 10 bar = 147 PSI)
Θερμοκρασία ζεστού νερού:	έως 70 °C
Συνιστώμενη θερμοκρασία ζεστού νερού:	65 °C
Θερμική απολύμανση:	έως 70 °C / 4 min

Το προϊόν έχει σχεδιαστεί αποκλειστικά για πόσιμο νερό!

Περιγραφή συμβόλων



Μην χρησιμοποιείτε οσλικόνη που περιέχει οξικό οξύ!

Ρύθμιση (βλ. Σελίδα 41)

Ρύθμιση του δοσομετρητή ζεστού νερού. Δεν συνιστάται η διάταξη φραγής ζεστού νερού σε συνδυασμό με ταχυθερμοσίφωνα.

Συντήρηση (βλ. Σελίδα 56)

Οι βαλβίδες αντεπιστροφής πρέπει να ελέγχονται τακτικά ως προς τη λειτουργία τους, σύμφωνα με το πρότυπο EN 806-5, σε σχέση με τους ισχύοντες εθνικούς ή τοπικούς κανόνες (το ελάχιστο μια φορά το χρόνο).

Διαστάσεις (βλ. Σελίδα 42)

Διάγραμμα ροής (βλ. Σελίδα 42)

Ανταλλακτικά (βλ. Σελίδα 48)

XXX = Χρώματα
000 = Επιχρωμιωμένο
670 = Matt Black
800 = Stainless Steel Optic

Ειδικά αξεσουάρ (δεν περιλαμβάνεται στον παραδοτέο εξοπλισμό)

 Σωλήνας επιμήκυνσης
#43333000 (βλ. Σελίδα 47)

 Καθαρισμός (βλ. Σελίδα 56)

 Χειρισμός (βλ. Σελίδα 50)

Η Hansgrohe συνιστά το πρωί ή μετά από μεγάλα χρονικά διαστήματα αχρησίας να μην χρησιμοποιείτε το πρώτο μισό λίτρο νερό σαν πόσιμο.

 Σήμα ελέγχου (βλ. Σελίδα 50)

Βλάβη	Αιτία	Διόρθωση
Πολύ μικρό SatinFlow / λίγο νερό	- Ακροφύσια και / ή μειωτής ροής έχουν ακαθαρσίες / άλατα	- Ακροφύσια και μειωτής ροής πρέπει να αποσυναρμολογηθούν και να καθαριστούν.
Η επαναφορά στο SatinFlow κολλάει	- Ακάθαρτο κουμπί επαναφοράς	- Αφαιρέστε το κουμπί επαναφοράς και καθαρίστε το
Η μπαταρία στάζει	- Ελαττωματικό φυσιγγίο	- Αλλαγή φυσιγγίου
Πολύ λίγο νερό στο εκτεινόμενο ρουζούνι	- Η διάταξη αντεπιστροφής νερού στη σύνδεση σωλήνα παροχής και στον ρυθμιστή δέσμης έχει άλατα / ακαθαρσίες	- Καθαρίστε τη διάταξη αντεπιστροφής νερού και τον ρυθμιστή δέσμης
Διαρροή νερού στον άξονα στερέωσης	- Οι σωλήνες σύνδεσης δεν είναι πλήρως βιδωμένοι στο βασικό κορμό	- Σφίξτε τους σωλήνες σύνδεσης με το χέρι
Το μήκος του εκτεινόμενου σπιδράλ σωλήνα παροχής δεν επαρκεί (μικρότερο από 500 mm)	- Το βάρος του σωλήνα παροχής έχει συναρμολογηθεί σε λάθος θέση	- Συναρμολογήστε το βάρος του σωλήνα παροχής σύμφωνα με τις οδηγίες συναρμολόγησης



Varnostna opozorila

- ⚠ Pri montaži je treba nositi rokavice, da se preprečijo poškodbe zaradi zmečkanja ali urezov.
- ⚠ Velike razlike v tlaku med priključkom za mrzlo in priključkom za toplo vodo je potrebno izravnati.

Navodila za montažo

- Pred montažo je treba izdelek preveriti glede morebitnih transportnih poškodb. Po vgradnji transportne ali površinske poškodbe ne bodo več priznane.
- Cevi in armaturo je treba montirati, izprati in preveriti po veljavnih standardih.
- Upoštevati je treba pravilnike o inštalacijah, ki veljajo v posamezni državi.

Tehnični podatki

Delovni tlak:	maks. 1 MPa
Priporočeni delovni tlak:	0,1 - 0,5 MPa
Preskusni tlak:	1,6 MPa (1 MPa = 10 bar = 147 PSI)
Temperatura tople vode:	maks. 70 °C
Priporočena temperatura tople vode:	65 °C
Termična dezinfekcija:	maks. 70 °C / 4 min

Proizvod je zasnovan izključno za sanitarno vodo!

Opis simbola



Ne smete uporabiti silikona, ki vsebuje ocetno kislino!



Justiranje (glejte stran 41)

Nastavitev omejevalnika tople vode. V povezavi s pretočnimi grelniki uporaba zapore tople vode ni priporočljiva.



Vzdrževanje (glejte stran 56)

Delovanje protipovratnega ventila je potrebno v skladu z EN 806-5 in skladno z državnimi in regionalnimi določili redno testirati (najmanj enkrat letno).



Mere (glejte stran 42)



Diagram pretoka (glejte stran 42)



Rezervni deli (glejte stran 48)

XXX = Barve
000 = Krom
670 = Matt Black
800 = Stainless Steel Optic

Poseben pribor (Ni vključeno)



Podaljšek #43333000 (glejte stran 47)



Čiščenje (glejte stran 56)



Upravljanje (glejte stran 50)

Hansgrohe priporoča, da zjutraj ali po daljšem času stagnacije prvega pol litra vode ne uporabite kot pitno vodo.



Preskusni znak (glejte stran 50)

Napaka	Vzrok	Pomoč
Pretok SatinFlow premajhen/premalo vode	- Umazane/vodni kamen v šobah in/ali omejevalniku pretoka	- Demontirajte in očistite šobe in omejevalnik pretoka.
Preklop na SatinFlow se zatika	- Umazan gumb za preklop	- Odstranite in očistite gumb za preklop
Iz armature kaplja	- Pokvarjen vložek	- Zamenjajte vložek
Premalo vode na izvlečnem izlivu	- Protipovratni ventil v cevnem priključku in regulator curka je poln vodnega kamna/umazan	- Očistite protipovratni ventil in regulator curka
Uhajanje vode ob pritrdilnem nastavku	- Priključne cevi niso popolnoma privijačene v osnovno ogrodje	- Ročno zatisnite priključne cevi
Izvelčna dolžina cevi prekratka (manj kot 500 mm)	- Obtežitev cevi nameščena v napačnem položaju	- Obtežitev cevi namestite v skladu z navodili za montažo



Ohutusjuhised

- △ Kandke paigaldamisel muljumis- ja löikevigastuste vältimiseks kindaid.
- △ Kui külma ja kuumaa vee ühenduste surve on väga erinev, tuleb need tasakaalustada.

Paigaldamisjuhised



- Enne paigaldamist tuleb toodet kontrollida transpordikahjustuste osas. Pärast paigaldamist ei tunnustata enam transpordi- või pinnakahjustuste kaebuseid.
- Voolikut ja segisti paigaldamisel, loputamisel ja kontrollimisel tuleb lähtuda kehtivatest normatiividest.
- Vastavas riigis kehtivaid paigalduseeskirju tuleb järgida.

Tehnilised andmed

Töörõhk	maks. 1 MPa
Soovitatav töörõhk:	0,1 - 0,5 MPa
Kontrollsurve:	1,6 MPa (1 MPa = 10 baari = 147 PSI)
Kuumaa vee temperatuur:	maks. 70°C
Soovitatav kuumaa vee temperatuur:	65°C
Termiline desinfektsioon:	maks. 70°C / 4 min

Toode on ette nähtud eranditult joogivee jaoks!

Sümbolite kirjeldus

-  Ärge kasutage äädikhapet sisaldavat silikooni!
-  **Reguleerimine** (vt lk 41)

Sooja vee piirangu seadistamine. Ühenduses boileritega ei ole sooja vee blokeeringu soovitatav.

Hooldus (vt lk 56)

Tagasilöögiklappide toimimist tuleb kooskõlas riiklike ja regionaalsete määrustega regulaarselt kontrollida vastavalt standardile EN 806-5 (vähemalt kord aastas).

Rike	Põhjus	Lahendus
SatinFlow liiga madal/vähe vett	- Düüsid ja/või veehulgapiiraja määratud/lubjastunud	- Eemaldage ja puhastage düüsid ja veehulgapiiraja.
Ümberseadistus SatinFlow peale kinni kiilunud	- Ümberseadistusnupp määratud	- Eemaldage ja puhastage ümberseadistusnuppu
Segisti tilgub	- Tööelement on katkine	- Vahetage tööelement
Väljatõmmatavast tilast tuleb liiga vähe vett	- Voolikuühenduse tagasivoolupiiraja ja joaregulaator lubjastunud/määratud	- Puhastage tagasivoolupiirajat ja joaregulaatorit
Veeleke kinnituse juures	- Ühendusvoolikud ei ole korralikult põhikorpuse külge kruvitud	- Kruvige ühendusvoolikud käega kinni
Väljatõmmatava vooliku pikkus liiga lühike (vähem kui 500 mm)	- Voolikuraskus paigaldatud valesse positsiooni	- Monteeri voolikuraskus vastavalt paigaldusjuhendile

Mõõtude (vt lk 42)



Läbivooludiagramm (vt lk 42)

Varuosad (vt lk 48)

- XXX = Värvid
- 000 = Kroom
- 670 = Matt Black
- 800 = Stainless Steel Optic

Spetsiaalne lisavarustus (ei sisaldu komplektis)

 Pikendus #43333000 (vt lk 47)

 **Puhastamine** (vt lk 56)

 **Kasutamine** (vt lk 50)

Hansgrohe soovib mitte kasutada esimest poolt liitrit hommikuti või pärast pikemat seisakuvaega joogiveena.

 **Kontrollsertifikaat** (vt lk 50)



Drošības norādes

- △ Montāžas laikā, lai izvairītos no saspiedumiem un iegriezumiem, nepieciešams nēsāt cimdus.
- △ Jāizlīdzina spiediena atšķirības starp aukstā un karstā ūdens pievadiem.

Norādījumi montāžai

- Pirms montāžas nepieciešams pārbaudīt, vai produktam transportēšanas laikā nav radušies bojājumi. Pēc iebūvēšanas bojājumi, kas radušies transportēšanas laikā, vai virsmas bojājumi netiek atzīti.
- Caurulvadi un armatūra ir jāuzstāda, jāizskalo un jāpārbauda saskaņā ar spēkā esošajiem standartiem.
- Jāievēro attiecīgās valstīs spēkā esošās montāžas prasības.

Tehniskie dati

Darba spiediens: maks. 1 MPa
 Ieteicamais darba spiediens: 0,1 - 0,5 MPa
 Pārbaudes spiediens: 1,6 MPa
 (1 MPa = 10 bar = 147 PSI)

Karstā ūdens temperatūra: maks. 70 °C
 Ieteicamā karstā ūdens temperatūra: 65 °C
 Termiskā dezinfekcija: maks. 70 °C / 4 min

Izstrādājums ir paredzēts tikai dzeramajam ūdenim!

Simbolu nozīme



Neizmantojiet silikonu, kas satur etiķskābi!



Ieregulēšana (skat. lpp. 41)

Karsta ūdens ierobežotāja regulēšana. Kopā ar caurteces sildītājiem nav ieteicams izmantot ūdens bloķētāju.



Apkope (skat. lpp. 56)

Regulāri jāpārbauda pretvārsta funkcija saskaņā ar EN 806-5 saistībā ar nacionālajiem vai vietējiem noteikumiem (vismaz vienreiz gadā).



Izmērus (skat. lpp. 42)



Caurplūdes diagramma (skat. lpp. 42)



Rezerves daļas (skat. lpp. 48)

XXX = Krāsu kodi
 000 = Hroma
 670 = Matt Black
 800 = Stainless Steel Optic

Speciāli aksesuāri

(komplektā netiek piegādāts)



Pagarinājums #43333000 (skat. lpp. 47)



Tīrīšana (skat. lpp. 56)



Lietošana (skat. lpp. 50)

Hansgrohe iesaka no rīta vai pēc ilgākiem pārtraukumiem nelietot pirmo puslitru ūdens dzeršanai.



Pārbaudes zīme (skat. lpp. 50)

Traucējums	Iemesls	Bojājumu novēršana
SatinFlow pārāk vājš / pārāk maz ūdens	- Sprauslas un / vai plūsmas ierobežotājs aizsērējis / apkalkots	- Demontēt un iztīrīt sprauslas un plūsmas ierobežotāju.
Pārslēgšanās uz SatinFlow aizķeras	- Pārslēgšanas taustiņš aizsērējis	- Izņemt pārslēgšanas taustiņu un iztīrīt
Jaucējkrāns pil	- Bojāta kartuša	- Nomainīt kartušu
Pārāk maz ūdens izvelkamajā izplūdes ierīcē	- Atpakaļplūsmas ierobežotājs šļūtenes plūsmā un strūkļas regulētājs apkalkots / aizsērējis	- Iztīrīt atpakaļplūsmas ierobežotāju un strūkļas regulētāju
Ūdens noplūde pie nostiprinājuma	- Pieslēguma šļūtenes nav līdz galam ieskrūvētas pamatelementā	- Pieslēguma šļūtenes ar roku pievilkt stingrāk
Izvelkamās šļūtenes garums pārāk mazs (mazāk par 500 mm)	- Šļūtenes svars montēts nepareizā pozīcijā	- Montēt šļūtenes svaru atbilstoši montāžas instrukcijai





Sigurnosne napomene

- △ Prilikom montaže se radi sprečavanja prignječenja i posekotine moraju nositi rukavice.
- △ Velika razlika u pritisku između vruće i hladne vode mora biti izbalansirana.

Instrukcije za montažu

- Pre montaže se mora proveriti da li je proizvod oštećen pri transportu. Nakon ugradnje se ne priznaju nikakve reklamacije koje se odnose na površinska i transportna oštećenja.
- Vodovi i armatura moraju biti postavljeni, isprani i testirani prema važećim normama.
- Treba se pridržavati propisa koji u određenim zemljama važe za instalacije.

Tehnički podaci

Radni pritisak:	maks. 1 MPa
Preporučeni radni pritisak:	0,1 - 0,5 MPa
Probni pritisak:	1,6 MPa
	(1 MPa = 10 bar = 147 PSI)
Temperatura vruće vode:	maks. 70°C
Preporučena temperatura vruće vode:	65°C
Termička dezinfekcija:	maks. 70°C / 4 min

Proizvod je koncipiran isključivo za pijaću vodu!

Opis simbola



Nemojte koristiti silikon koji sadrži sirćetnu kiselinu!



Podešavanje (vidi stranu 41)

Podešavanje ograničivača tople vode. U kombinaciji sa protočnim bojlerima ne preporučuje se primena sistema za blokiranje dotoka tople vode.



Održavanje (vidi stranu 56)

Ispravno funkcionisanje nepovratnog ventila se mora redovno proveravati prema standardu EN 806-5 i u skladu s važećim nacionalnim ili regionalnim propisima (najmanje jednom godišnje).



Mere (vidi stranu 42)



Dijagram protoka (vidi stranu 42)



Rezervni delovi (vidi stranu 48)

XXX = Oznake boja

000 = Hrom

670 = Matt Black

800 = Stainless Steel Optic

Poseban pribor (Nije sadržano u isporuci)



Produžetak #43333000 (vidi stranu 47)



Čišćenje (vidi stranu 56)



Rukovanje (vidi stranu 50)

Hansgrohe preporučuje da ujutru ili nakon dužeg nekorisćenja prvih pola litre vode ne koristite za piće.



Ispitni znak (vidi stranu 50)

Smetnja	Uzrok	Pomoć
SatinFlow premali protok / premalo vode	- Mlaznice i/ili ograničivač protoka zaprljani / sa naslagama kamenca	- Izvadite i očistite mlaznice i ograničivač protoka.
Preusmerivač na SatinFlow	- Dugme preusmerivača zaprljano	- Skinite i očistite dugme preusmerivača
Slavina kaplje	- Neispravna kartuša	- Zamenite kartušu
Premalo vode u izvlačnom ispustu	- Nepovratni ventil u priključku creva i regulatoru mlaza sa naslagama kamenca	- Očistite nepovratni ventil i regulator mlaza
Voda izlazi na delu gde je slavina učvršćena	- Priključna creva nisu potpuno učvršćena na telo	- Priključna creva učvrstite rukom
Prekratka izvlačna dužina creva (manje od 500 mm)	- Teg creva montiran na pogrešnom mestu	- Montirajte teg creva u skladu sa uputstvom za montažu



Sikkerhetshenvisninger

- △ Bruk hansker under montasjen for å unngå klem- og kuttskader.
- △ Store trykkdifferanser mellom kaldt- og varmtvannstilkoblinger skal utlignes.

Montagehenvisninger

- Før montasjen skal produktet sjekkes for transportskader. Etter monteringen aksepteres ikke noen transport- eller overflateskader.
- Ledningene og armaturen skal monteres, spyles og sjekkes iht. de gyldige normer.
- Gjeldende retningslinjer for rørleggerarbeid i de enkelte land skal følges.

Tekniske data

Driftstrykk	maks. 1 MPa
Anbefalt driftstrykk:	0,1 - 0,5 MPa
Prøvetrykk	1,6 MPa (1 MPa = 10 bar = 147 PSI)
Varmtvannstemperatur	maks. 70°C
Anbefalt temperatur for varmt vann	65°C
Termisk desinfisering:	maks. 70°C / 4 min

Produktet er utelukkende designet for drikkevann!

Symbolbeskrivelse



Ikke bruk silikon som inneholder eddiksyre!



Justering (se side 41)

Innstilling av varmtvannsbegrensning. I forbindelse med gjennomstrømningsvarmere er det ikke anbefalt å bruke en varmtvannsperre.



Vedlikehold (se side 56)

Funksjonen til returløspssperren skal iht. EN 806-5 og i samsvar med de nasjonale og lokale forskrifter sjekkes regelmessig (minst en gang i året).



Mål (se side 42)



Gjennomstrømningsdiagram

(se side 42)



Serviceleder (se side 48)

XXX = Fargekode

000 = Krom

670 = Matt Black

800 = Stainless Steel Optic

Ekstratilbehør (ikke med i leveransen)



Forlengelse #43333000 (se side 47)



Rengjøring (se side 56)



Betjening (se side 50)

Om morgen og etter lengre stagnasjonstider anbefaler Hansgrohe å ikke bruke den første halvliteren som drikkevann.



Prøvemerket (se side 50)

Feil	Årsak	Feilrettelse
SatinFlow for lav / lite vann	- Dyser og / eller strømningsbegrensninger skitten / forkalket	- Demonter dyser og strømningsbegrensninger og rengjør dem.
Omstilling til SatinFlow i klemme	- Omstillingsknappen skitten	- Ta av omstillingsknappen og rengjør den
Armatur drypper	- Kartusj defekt	- Kartusj byttes
For lite vann i uttrekksavløpet	- Tilbakeslagsventilen i slangekoblingen og strålerregulatoren forkalket / skitten	- Rengjør tilbakeslagsventilen og strålerregulatoren
Vannlekkasje på festeskaft	- Tilkoblingsslanger ikke skrudd helt inn i basiselement	- Tilkoblingsslanger trekkes fast fra hånd
Uttrekkslengden på slangen er for kort (mindre enn 500 mm)	- Slangevekten er montert i feil posisjon	- Monter slangevekten i henhold til monteringsanvisningen





Указания за безопасност

- △ При монтажа трябва да се носят ръкавици, за да се избегнат наранявания поради притискане или порязване.
- △ Големите разлики в налягането между изводите за студената и топлата вода трябва да се изравняват.

Указания за монтаж

- Преди монтажа продуктът трябва да се провери за транспортни щети. След монтажа не се признават транспортни или повърхностни щети.
- Тръбопроводите и арматурата трябва да се монтира, промият и проверят в съответствие с валидните норми.
- Трябва да бъдат спазвани валидните в съответните страни предписания за инсталиране.

Технически данни

Работно налягане: макс. 1 МПа
 Препоръчително работно налягане: 0,1 - 0,5 МПа
 Контролно налягане: 1,6 МПа
 (1 МПа = 10 bar = 147 PSI)
 Температура на горещата вода: макс. 70 °C
 Препоръчителна температура на горещата вода: 65 °C
 Термична дезинфекция: макс. 70 °C / 4 мин
 Продуктът е разработен само за питейна вода!

Описание на символите



Не използвайте силикон, съдържащ оцветна киселина!



Юстиране (вижте стр. 41)

Настройка на ограничителя за топлата вода. Във връзка с проточни нагреватели не се препоръчва блокировка за топлата вода



Поддръжка (вижте стр. 56)

Съгласно EN 806-5 функционирането на приспособленията за предотвратяване на обратния поток трябва редовно да се проверява в съответствие с националните или регионални изисквания (поне веднъж годишно).



Размери (вижте стр. 42)



Диаграма на потока (вижте стр. 42)



Сервизни части (вижте стр. 48)

XXX = Цветово кодиране
 000 = Хром
 670 = Matt Black
 800 = Stainless Steel Optic

Специални принадлежности

(не се съдържа в обема на доставка)



Удължител #43333000 (вижте стр. 47)



Почистване (вижте стр. 56)



Обслужване (вижте стр. 50)

Hansgrohe препоръчва, сутрин и след по-продължително спиране първият половин литър да не се използва като питейна вода.



Контролен знак (вижте стр. 50)

Неизправност	Причина	Помощ
SatinFlow твърде малък / малко вода	- Дюзите и/или ограничителят на протичане са замърсени/покрити с варовик	- Свалете дюзите и ограничителя на протичане и ги почистете.
Преходникът за SatinFlow заяжда	- Копчето за превключване е замърсено	- Свалете копчето за превключване и го почистете
Арматурата капе	- Дефектна гилза	- Сменете гилзата
Твърде малко вода от издърпващия се душ	- Приспособлението за предотвратяване на обратния поток в извода за маркуча и регулатора на струята са покрити с варовик/замърсени	- Почистете приспособлението за предотвратяване на обратния поток и регулатора на струята
Избиване на вода от закрепващата шийка	- Свързващите маркучи не са напълно завинтени в основното тяло	- Затегнете на ръка свързващите маркучи
Дължината на изтегляне на маркуча е твърде къса (по-малка от 500 mm)	- Тежестта за маркуча е монтирана на грешното място	- Монтирайте тежестта за маркуча съгласно ръководството за монтаж



Udhëzime sigurie

- △ Për të evituar lëndimet e pickimeve ose të prerjeve gjatë procesit të montimit duhet që të vishni doreza.
- △ Ndryshimet e mëdha të presionit mes lidhjeve të ujit të ftohtë dhe atij të ngrohtë duhen ekuilibruar.

Udhëzime për montimin

- Përpara montimit duhet që produkti të kontrollohet për dëmtime nga transporti. Pas instalimit nuk do të njihet asnjë dëmtim nga transporti ose dëmtim i sipërfaqes.
- Tubacionet dhe rubinetet duhet që të montohen, të shpëlahen dhe të kontrollohen sipas standardeve në fuqi
- Duhet të respektohen linjat udhëzuese të instalimit, të vlefshme për vendet respektive.

Të dhëna teknike

Presioni gjatë punës	maks. 1 MPa
Presioni i rekomanduar:	0,1 - 0,5 MPa
Presioni për provë:	1,6 MPa (1 MPa = 10 bar = 147 PSI)
Temperatura e ujit të ngrohtë	maks. 70°C
Temperatura e rekomanduar e ujit të ngrohtë:	65°C
Dezinfektim Termik:	maks. 70°C / 4 min
Produkti është projektuar ekskluzivisht për ujë të pijshëm!	

Përshkrimi i simbolit



Mos përdorni silikon që në përbërje ka acid acetik.



Justimi (shih faqen 41)

Rregullimi i kufizimit me ujë të nxehtë. Një kombinim me një bojler ujit nuk është i rekomanduar.

Dëmtim	Shkaku	Ndihme
SatinFlow shumë i ulët/pak ujë	- Ndotje/kalcifikim i hundëzave dhe/ose kufizuesit të rrjedhës	- Çmontoni dhe pastroni hundëzat dhe kufizuesin e rrjedhës.
Konvertimi në SatinFlow ka ngecur	- Butoni i konvertimit është i ndotur	- Hiqni dhe pastroni butonin e konvertimit
Armatura pikon	- Kartusha me defekt	- Kembeni kartushen
Ka shumë pak ujë në grykën e tërheqshme	- Kalcifikim/ndotje e valvulit të moskthimit në bashkuesin e zorrës dhe rregullatorit të prurjes	- Pastroni valvulin e moskthimit dhe rregullatorin e prurjes
Dalje e ujit në cilindrin fiksues	- Tubat e lidhjes jo komplet të vidhosur në karkasen baze	- Shtrengojini manualisht tubat e lidhur
Gjatësia e tërheqjes së zorrës shumë e shkurtër (më pak se 500 mm)	- Kundërpesha e zorrës është montuar në pozicion të gabuar	- Montojeni kundërpeshën e zorrës sipas udhëzimeve të montimit



Mirëmbajtja (shih faqen 56)

Penguesit e rrjedhjes në drejtim të kundërt duhen kontrolluar rregullisht në bazë të normave EN 806-5 konform normave nacionale dhe regionale (së paku një herë në vit).



Përmasat (shih faqen 42)



Diagrami i qarkullimit (shih faqen 42)



Pjesët e servisit (shih faqen 48)

XXX = Kodimi me anë të ngjyrave
000 = Krom
670 = Matt Black
800 = Stainless Steel Optic

Pajisje të posaçme

(nuk përfshihet në vëllimin e furnizimit)



Zgjatës #43333000 (shih faqen 47)



Pastrimi (shih faqen 56)



Përdorimi (shih faqen 50)

Hansgrohe rekomandon që në mëngjes ose pas periudhave të gjata që gjysmë litri i parë mos të pihet



Shenja e kontrollit (shih faqen 50)





الصيانة (راجع صفحة 56)

يجب فحص صمام عدم الرجوع بصفة منتظمة حسب المواصفة 5-EN 806 وذلك طبقاً للوائح الوطنية أو الإقليمية (مرة واحد سنوياً على الأقل).

أبعاد (راجع صفحة 42)

رسم للصراف (راجع صفحة 42)

قطع الغيار (راجع صفحة 48)

الألوان = XXX

كروم = 000

Mat Black = 670

Stainless Steel Optic = 800

ملحقات خاصة

(غير مدرج مع المحتويات المسلمة)

وصلة إطالة #43333000 (راجع صفحة 47)

التنظيف (راجع صفحة 56)

التشغيل (راجع صفحة 50)

تتصح شركة هانز جروهي Hansgrohe بعدم استخدام أول نصف لتر من الماء لغرض الشرب وذلك في الصباح أو بعد توقف استخدام الماء لفترات طويلة نسبياً.

شهادة اختبار (راجع صفحة 50)

تنبيهات الأمان

- ⚠ يجب إرتداء قفازات لليد أثناء التركيب لتجنب حدوث أضرار الإنحشار أو الجروح.
- ⚠ يجب أن يكون تيار الماء الساخن والماء البارد متعادلين في الضغط.

تعليمات التركيب

- قبل القيام بعملية التركيب، يجب فحص المنتج للتأكد من خلوه من أية تلفيات ناتجة عن النقل. بعد القيام بعملية التركيب، لن يتم الاعتراف بوجود أية تلفيات سطحية أو تلفيات ناتجة عن عملية النقل.
- يجب تركيب وغسيل واختبار التوصيلات وخلطات المياه طبقاً للمعايير السارية.
- يجب مراعاة القواعد الخاصة بالتركيب وأعمال السباكة وفقاً للوائح الخاصة بكل بلد.

المواصفات الفنية

- ضغط التشغيل: الحد الأقصى 1 ميجاباسكال
- ضغط التشغيل الموصى به: 0,1 - 0,5 ميجاباسكال
- ضغط الاختبار: 1,6 ميجاباسكال
- (1 ميجاباسكال = 10 بار = 147 PSI)
- درجة حرارة الماء الساخن: الحد الأقصى 70°C
- درجة الحرارة الموصى بها للماء الساخن: 65°C
- تقديم حراري: الحد الأقصى 4 / 70°C الدقيقة
- المنتج مخصص فقط لماء الشرب!

وصف الرمز

هام! لا تستخدم السليكون الذي يحتوي على أحماض!

الضبط (راجع صفحة 41)

ضبط تحديد المياه الدافئة. لا ينصح باستخدام محدّد المياه الدافئة مع سخان المياه الوقتي.

العطل	السبب	العلاج والإصلاح
SatinFlow لكمية قليلة جداً / قليلة من الماء	- إذا كانت الفوهات و/أو ضابطة التدفق متسخة/متكلسة	- فقم بحلّ الفوهات وضابطة التدفق وتنظيفها
إذا كان التحويل إلى SatinFlow عالقاً	- إذا كان مفتاح التحويل متسخ	- فقم بإزالة مفتاح التحويل ونظفه
تساقط قطرات مياه من الخلاط	- الخرطوشة تالفة	- قم بتغيير الخرطوشة
إذا كانت هناك كميات قليلة جداً من الماء في مخرّج التمديد	- إذا كان مانع الارتجاع في وصلة الخرطوم والفوهة المُنظمة للتدفق متسخان / مُتكلسان	- فقم بتنظيف مانع الارتجاع والفوهة المُنظمة للتدفق
خروج الماء من جزء التثبيت	- خرطوم التوصيل ليست مربوطة في الجزء الرئيسي بشكل كامل	- اربط خرطوم التوصيل بيدك
إذا كان طول خرطوم التمديد قصير جداً (أقل من 500 مم)	- وكان ثقل الخرطوم مثبت في الوضع الخاطئ	- فقم بتثبيت ثقل الخرطوم وفقاً لتعليمات التركيب



Biztonsági utasítások

- △ A szerelésnél a zúzódások és vágási sérülések elkerülése érdekében kesztyűt kell viselni.
- △ A hidegvíz- és a melegvíz-csatlakozások közötti nagy nyomáskülönbséget kikell egyenlíteni!

Szerelési utasítások

- A szerelés előtt ellenőrizni kell, hogy a terméknek nincs-e szállítási sérülése. Beépítés után a szállítási- vagy felületi sérüléseket nem ismerik el.
- A vezetékeket és a csaptelepet az érvényes szabványoknak megfelelően kell felszerelni, öblíteni és ellenőrizni
- Az egyes országokban érvényes installációs irányelveket be kell tartani.

Műszaki adatok

Üzemi nyomás:	max. 1 MPa
Ajánlott üzemi nyomás:	0,1 - 0,5 MPa
Nyomáspróba:	1,6 MPa
	(1 MPa = 10 bar = 147 PSI)
Forróvíz hőmérséklet:	max. 70 °C
Forróvíz javasolt hőmérséklete:	65 °C
Termikus fertőtlenítés:	max. 70 °C / 4 perc

A terméket kizárólag ivóvízhez tervezték!

Szimbólumok leírása



Ne használjon ecetsavtartalmú szilikon!



Beállítás (lásd a oldalon 41)

A meleg víz korlátozás beállítása. Átfolyós vízmelegítőknél meleg víz korlátozó használata nem ajánlott.



Karbantartás (lásd a oldalon 56)

A visszafolyásgátlók működése a EN 806-5 szabványnak megfelelően, a nemzeti vagy területi rendelkezésekkel összhangban, évente egyszer ellenőrizendő!



Méretet (lásd a oldalon 42)



Átfolyási diagramm

(lásd a oldalon 42)



Tartozékok (lásd a oldalon 48)

XXX = Színkódolás

000 = Króm

670 = Matt Black

800 = Stainless Steel Optic

Egyéb tartozékok

(a szállítási egység nem tartalmazza)



Hosszabbítás #43333000 (lásd a oldalon 47)



Tisztítás (lásd a oldalon 56)



Használat (lásd a oldalon 50)

- A csaptelepeken átfolyt víz hőmérséklete fogyasztásra szánt víz esetében a 65 °C-ot nem haladhatja meg. A csaptelep nem eredményezheti az emberi fogyasztásra (pl. ivás és főzés céljából) szánt víz minőségromlását.
- Beüzemelés és üzemszünetek után szigorúan be kell tartani a használati útmutatóban leírtakat. Beüzemeléskor a csaptelepet át kell öblíteni, legalább 2 percig történő hideg- és melegvízes folyamatot javasolunk. Minimum 1 napos üzemszünet után fogyasztás előtt a csaptelepben stagnáló hideg- illetve melegvíz fogyasztása nem javasolt, a csaptelepben stagnáló vizet ki kell engedni, legalább 2 perces folytatás javasolt. A kifolytatás során nyert vizet ivóvízként, illetve ételkészítési céllal felhasználni nem szabad.
- Tekintettel arra, hogy a forró víz fémoldó képessége a hideg víznél nagyobb, emiatt főzés ivás céljából az OKI a hideg víz használatát javasolja.
- A csaptelepek perlátorát javasolt havonta vízkőtelepíteni, illetve fertőtleníteni. A csaptelepek tisztítása, fertőtlenítése során kizárólag olyan vegyszer alkalmazható, amely megfelel a 201/2001. (X.25) Kormányrendelet, illetve a 38/2003. (VII.7) ÉSzcSM-FVM-KvVM együttes rendeletben leírtaknak.
- A perlátor működési elvéből adódóan jelentős aeroszolt képez, így Legionella expozíció szempontjából fokozott kockázatot jelent. Ezért alkalmazása nem javasolt az egészségügyi intézmények fekvőbeteg ellátó szobáiban, illetve minden olyan helyen, ahol a hideg és / vagy használati melegvíz Legionella csírászama eléri a 49/2015 (XI.6.) EMMI rendelet alapján meghatározott beavatkozási szintet.



Vizsgajel (lásd a oldalon 50)



Hiba	Ok	Megoldás
SatinFlow túl kicsi / kevés víz	- Fűvókák és / vagy átfolyás-szabályozó elszennyeződött / vízköves	- Szerelje ki és tisztítsa meg a fűvókákat és az átfolyás-szabályozót.
A SatinFlow átállítása szorul	- Az átállító gomb elszennyeződött	- Távolítsa el és tisztítsa meg az átállító gombot
Csöpög a csap.	- A kerámiabetét meghibásodott.	- A kerámiabetétet ki kell cserélni.
Túl kevés víz van a szívókifolyónál	- A visszafolyás-gátló a tömlőcsatlakozónál és sugárszabályozó vízköves / elszennyeződött	- Tisztítsa meg a visszafolyás-gátlót és sugárszabályozót
Vízkilépés a rögzítőrúdon	- A csatlakozótömlők nincsenek teljesen becsavarozva az akaptestbe	- A csatlakozótömlőket kézzel meghúzni
Tömlő szívóhosszúság túl rövid (rövidebb, mint 500 mm)	- A tömlősúly nincs megfelelő helyzetben	- Szerelje fel a tömlősúlyt a szerelési utasításnak megfelelően

**安全上の注意**

- △ 施工の際は手を挟んだり怪我をしないように、手袋をはめてください。
- △ 給水・湯の圧力差は0.1(MPa)以内としてください。

施工上の注意

- 製品の施工前に輸送でのダメージがないか確認してください。施工後のキズ等のお申し出はお断りさせて頂いています。
- 配管と水栓は、関連法規に従って施工、洗浄、および試験を行ってください。
- 施工行う地域に適用される関連法規をお守りください。

技術資料

使用圧力:	最大 1 MPa
推奨使用水圧:	0,1 - 0,5 MPa
耐圧試験圧力:	1,6 MPa

(1 MPa = 10 bar = 147 PSI)

給湯温度:	最大 70°C
推奨給湯温度:	65°C
お湯による高温消毒:	最大 70°C / 4分

この製品は飲料水での使用が前提となっています(日本においては水道法に適合する飲料水)!

アイコンの説明

酢酸系シリコンをご使用にならないでください!



調整 (次のページを参照 41)

お湯の流量制限の設定方法。瞬間湯沸かし器をご利用の際はお湯の流量制限はしないでください。



メンテナンス (次のページを参照 56)

逆止弁は、EN 806-5に従って定期的(少なくとも年に1回)に確認をしてください(日本においては関連法規に従ってください)。



寸法 (次のページを参照 42)



流量曲線図 (次のページを参照 42)



スペアパーツ

(次のページを参照 48)

XXX = 仕上げ色

000 = Chrome

670 = Matt Black

800 = Stainless Steel Optic

スペシャルパーツ (別手配部品)



延長部材 #43333000

(次のページを参照 47)



お手入れ方法

(次のページを参照 56)



使用方法 (次のページを参照 50)

ハンスグローエは、朝または長い間使用されなかった後に吐水する最初の0.5リットルは飲料水として使用しないことをお勧めします。



認証について

(次のページを参照 50)

症状	原因	対応策
SatinFlowが少なすぎる/水量が少ない。	- ノズルや流量制限器の汚れ/石灰沈着	- ノズルと流量制限器を取り外して清掃します。
SatinFlowへの変換が止まっています。	- 変換ボタンが汚れています。	- 変換ボタンを取り外して清掃します。
水栓の水漏れ	- カートリッジの不良	- カートリッジを交換してください
引き出し式水栓ヘッドへの水量が少なすぎます。	- ホース接続部の逆流防止装置およびジェットレギュレーターの石灰沈着/汚れ	- 逆流防止装置とジェットレギュレーターを清掃します。
固定ネジ部分から水が漏れる	- 接続ホースが本体に完全にねじ込まれていない	- 接続ホースを手で増し締めしてください
引き出しホースが短すぎます(500 mm未満)。	- ホースの重力ボールが間違った位置に取り付けられています。	- 組立説明書に従って重力ボールを取り付けます。

施工方法 (次のページを参照 33)



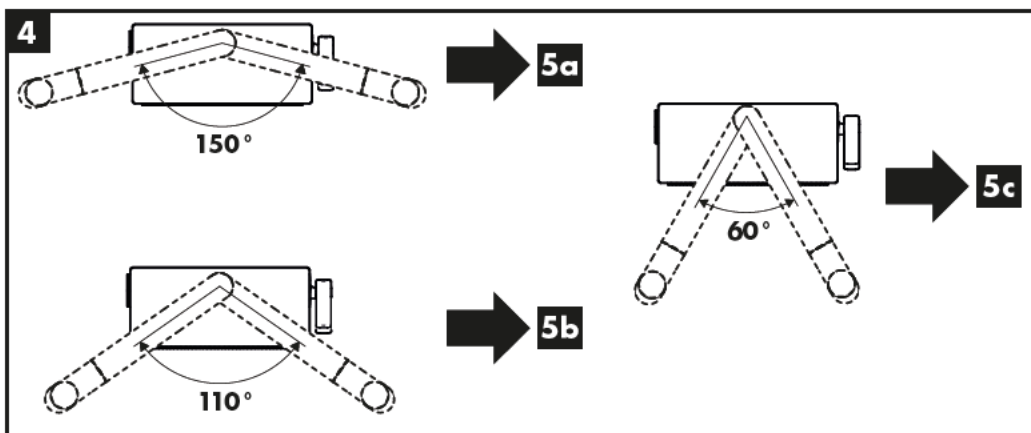
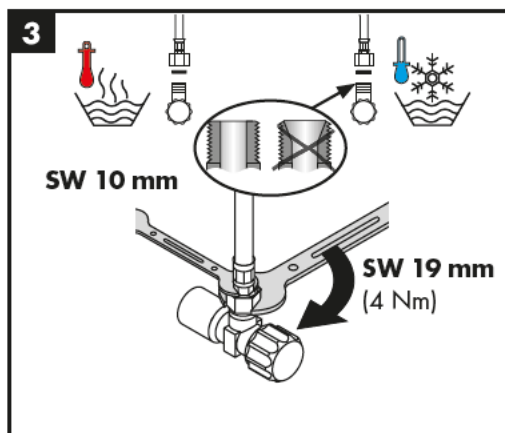
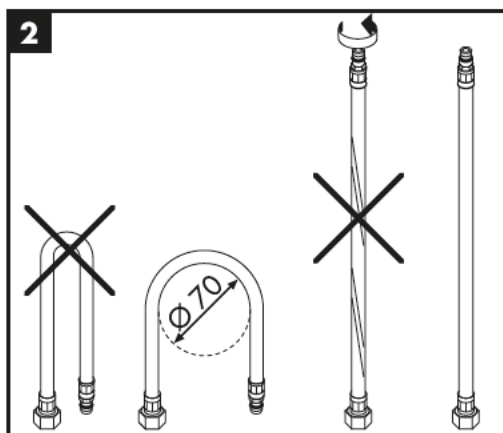
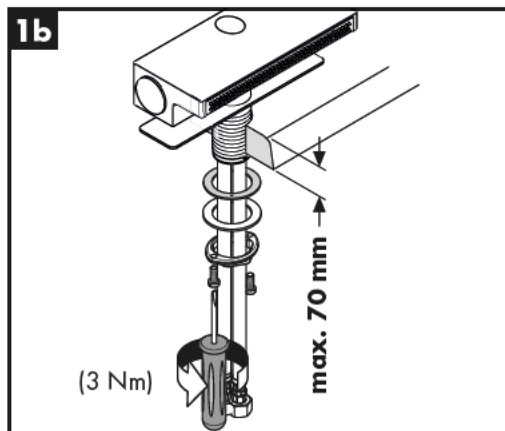
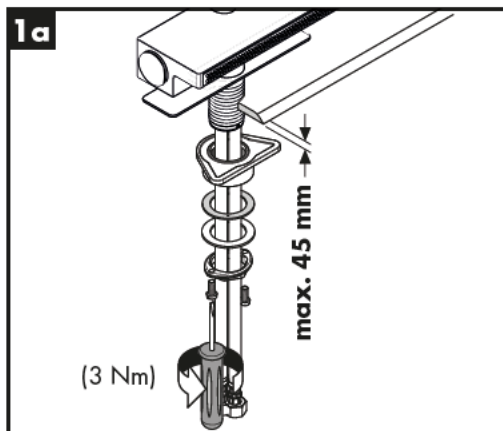



5a

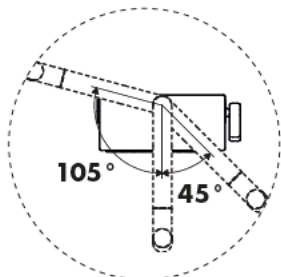
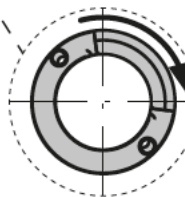
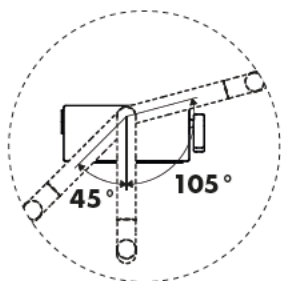
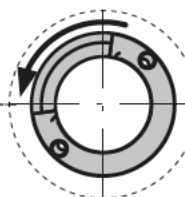
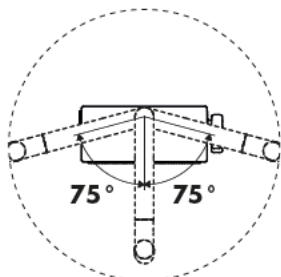
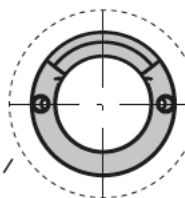
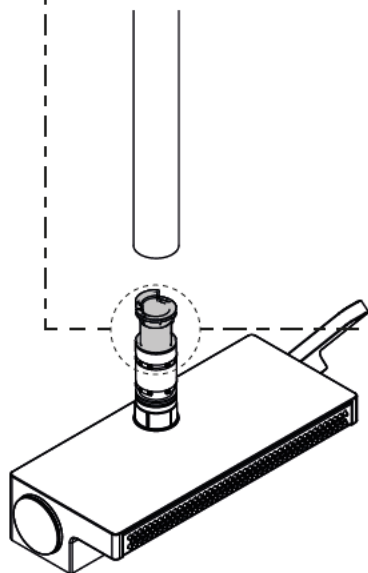
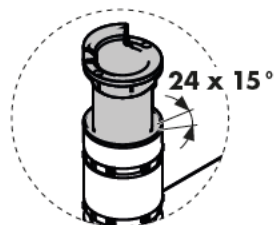
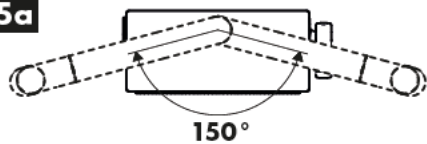



5b

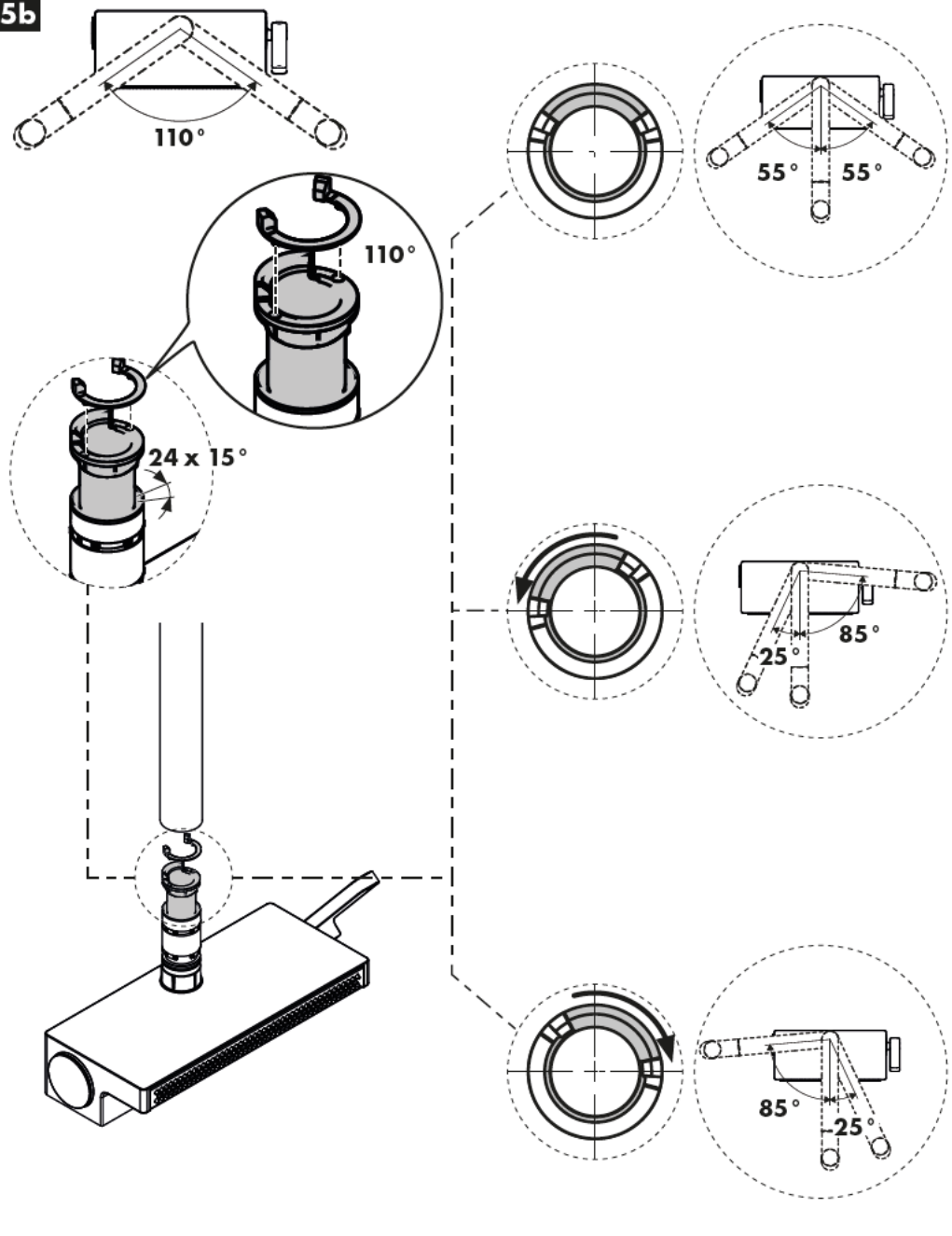



5c

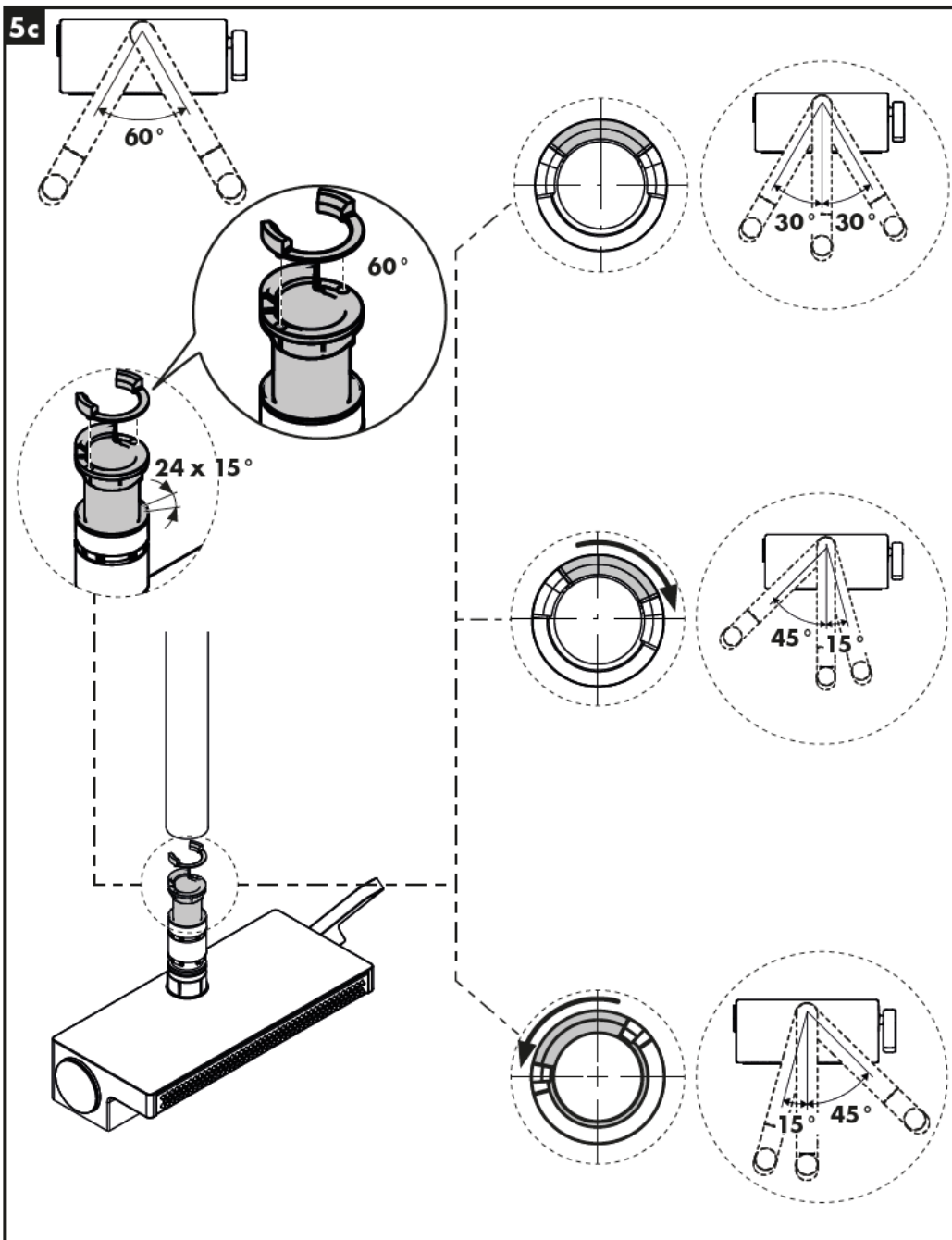

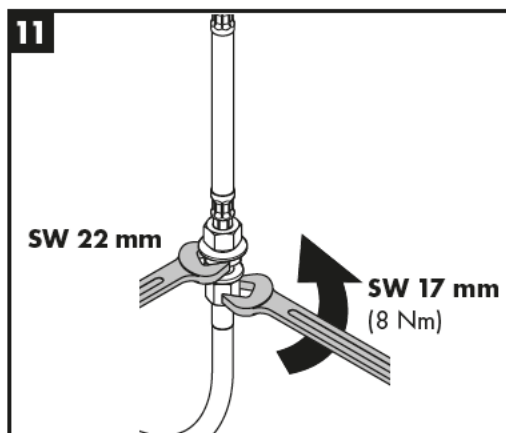
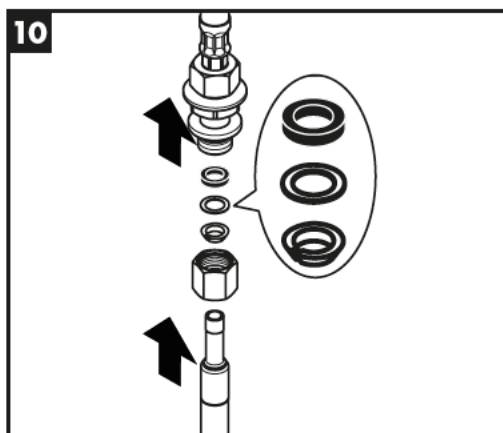
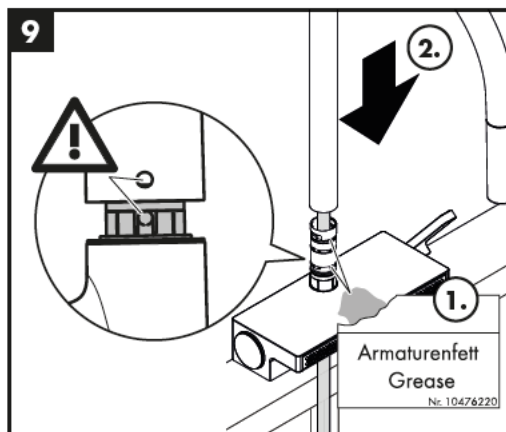
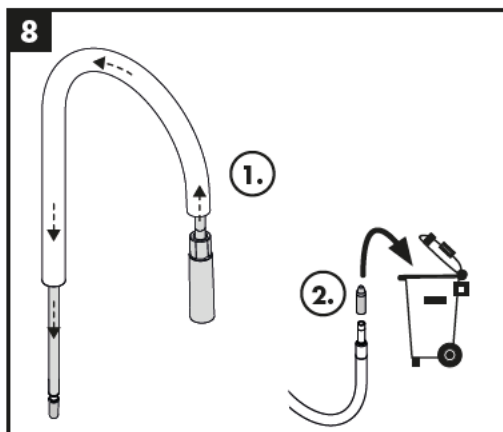
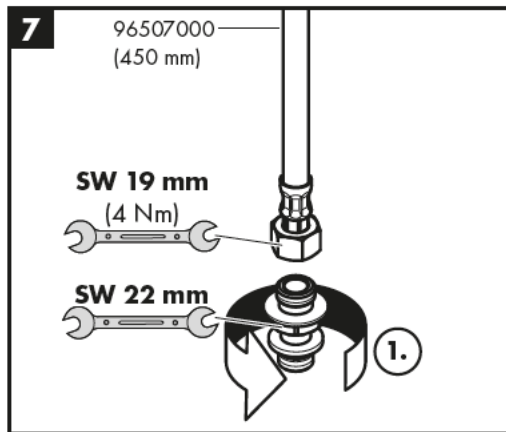
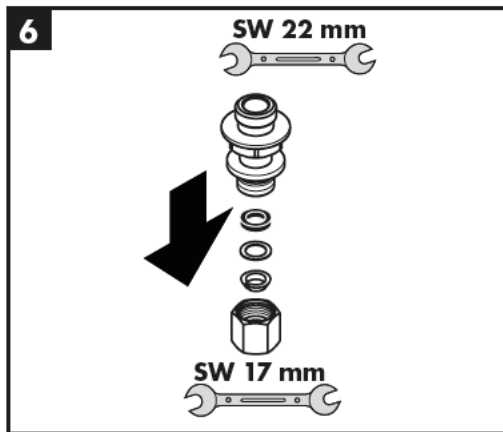

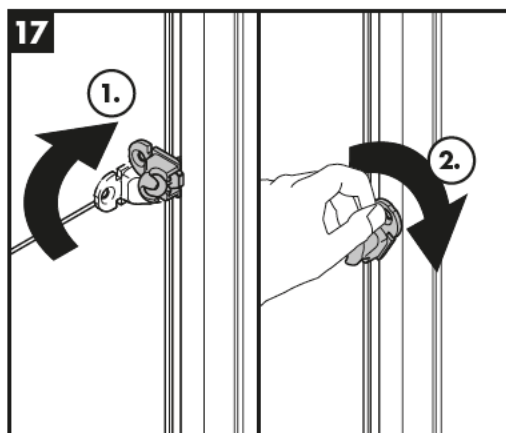
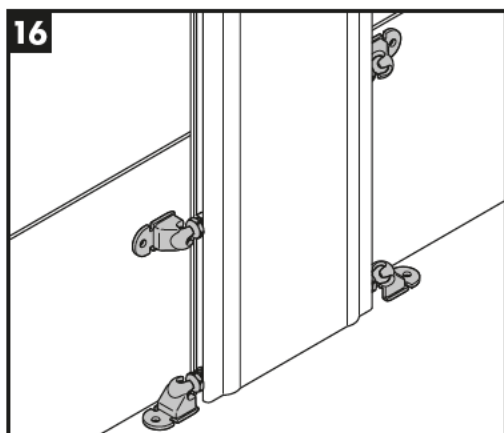
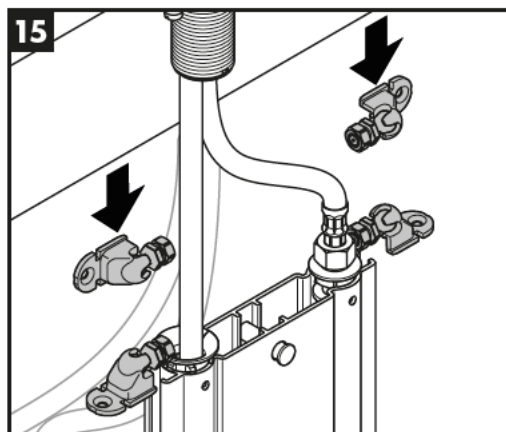
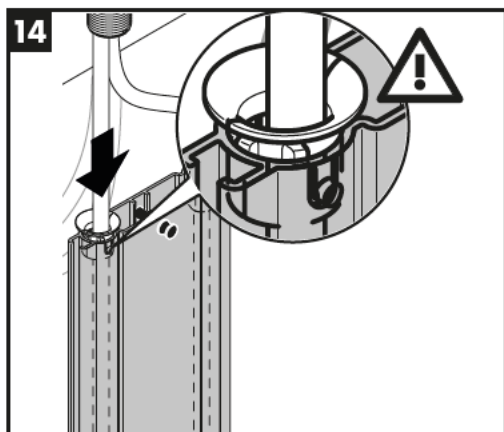
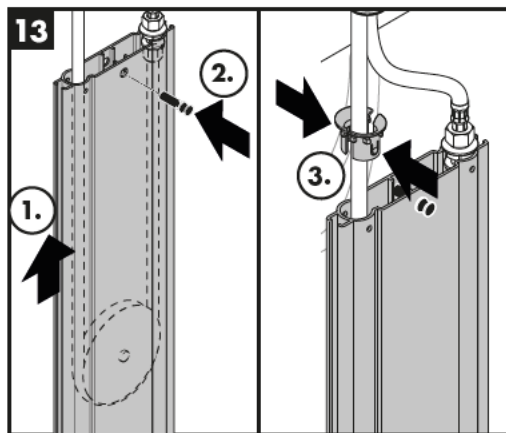
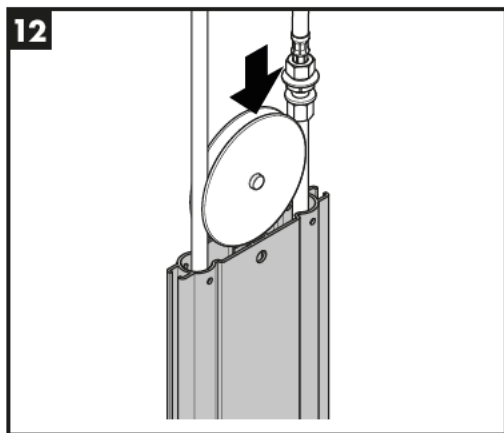

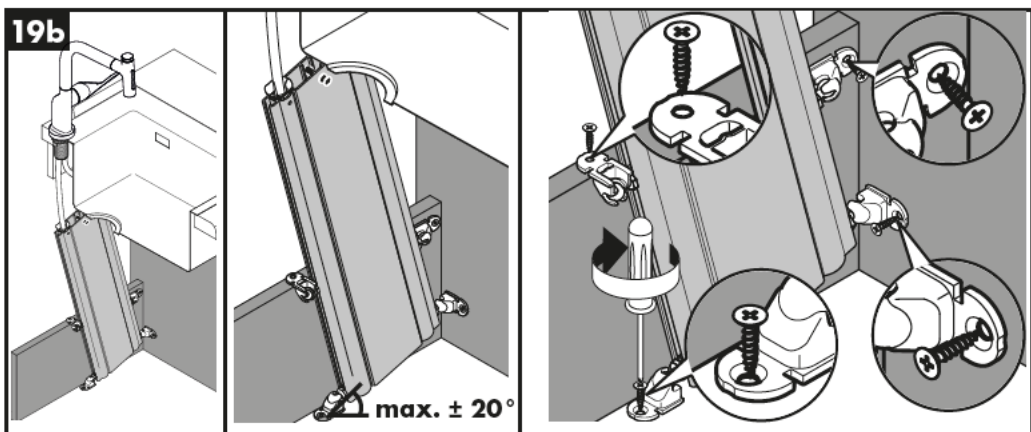
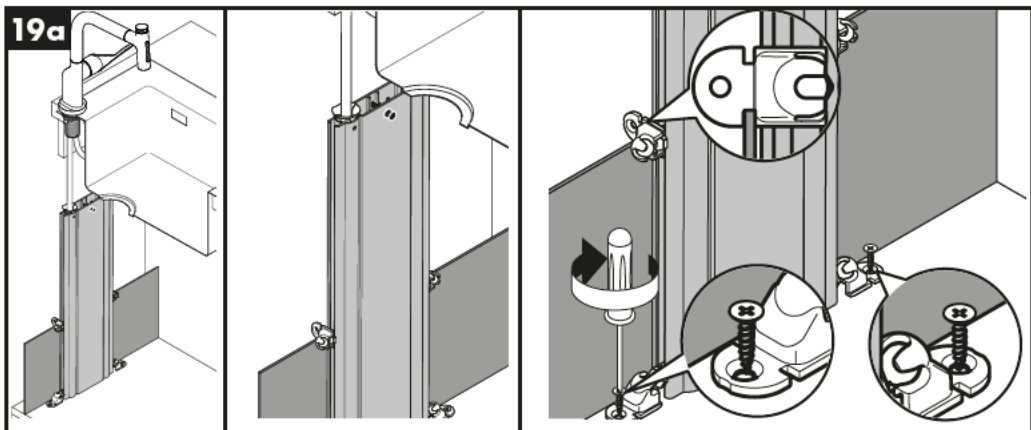
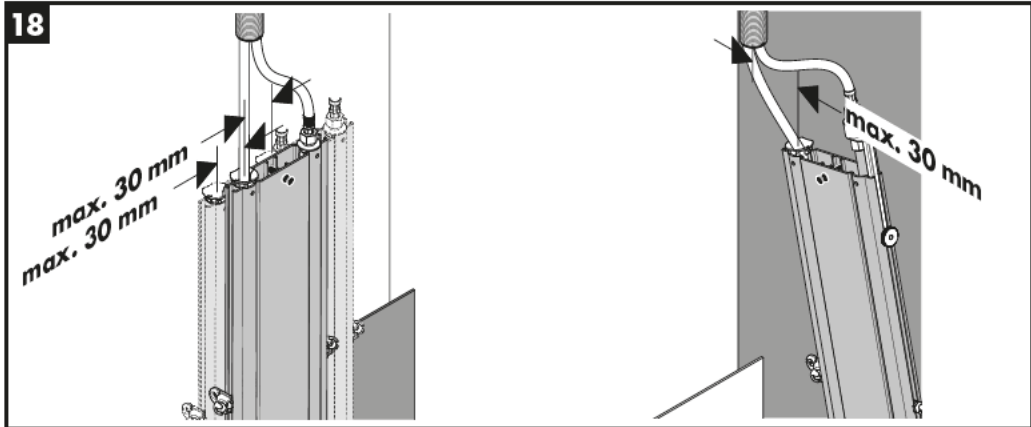

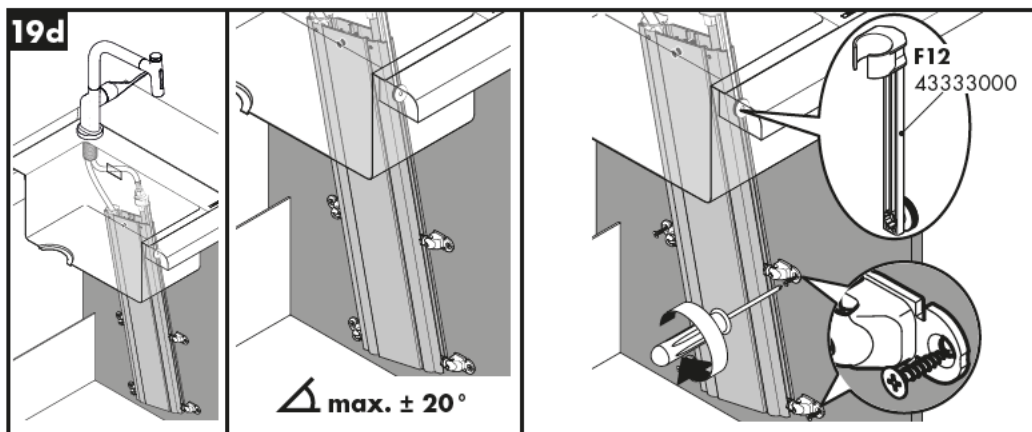
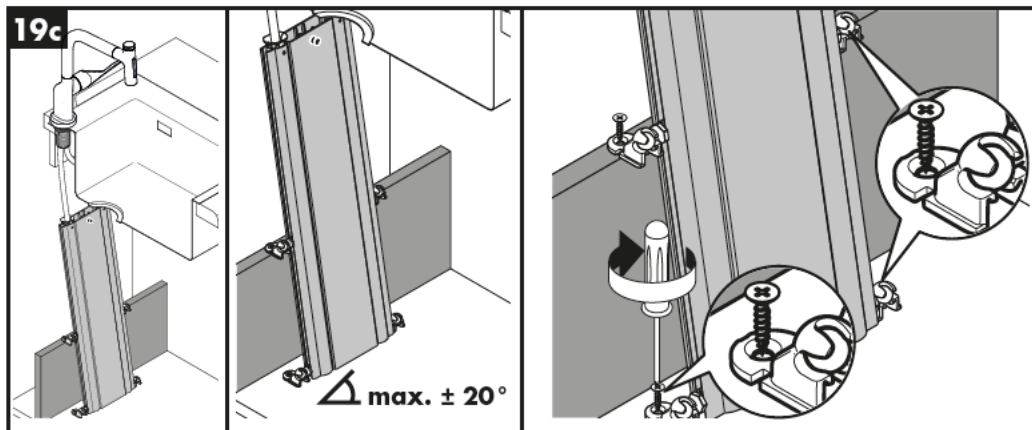



60 °C



10 °C



0,3 MPa

0,3 MPa

0,3 MPa لاکسیجیہ

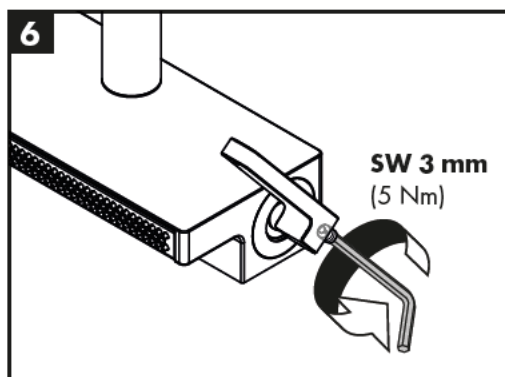
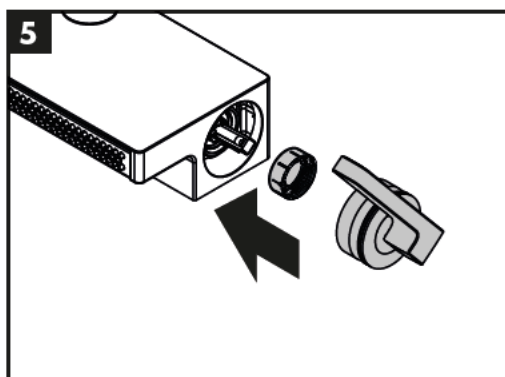
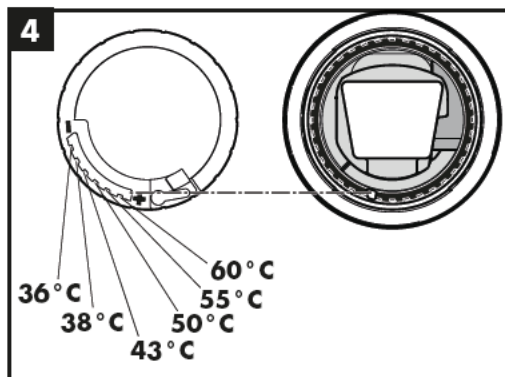
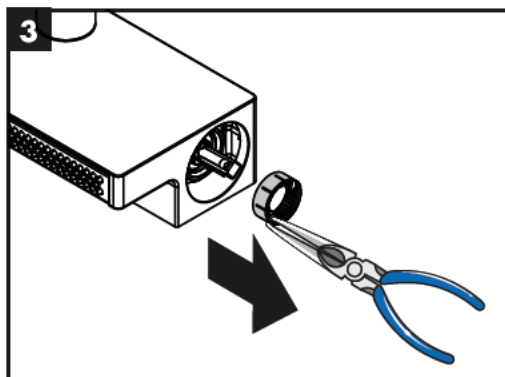
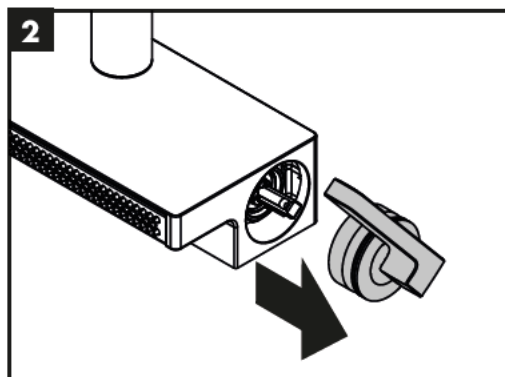
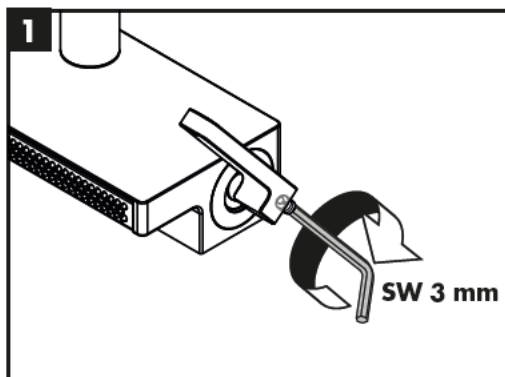



Aquno Select M81 170 3jet sBox

73831XXX

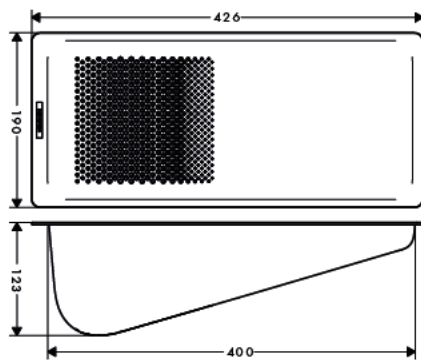
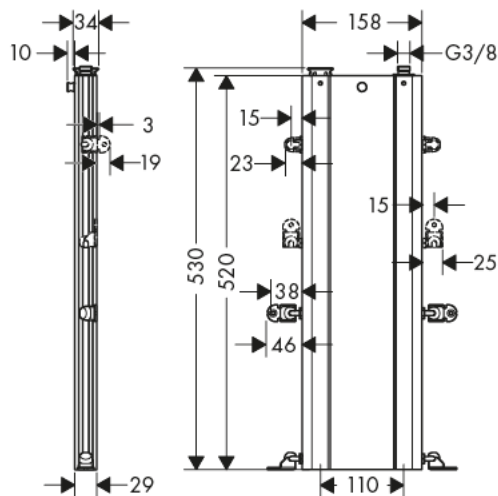
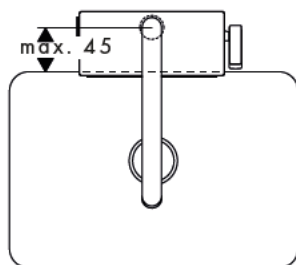
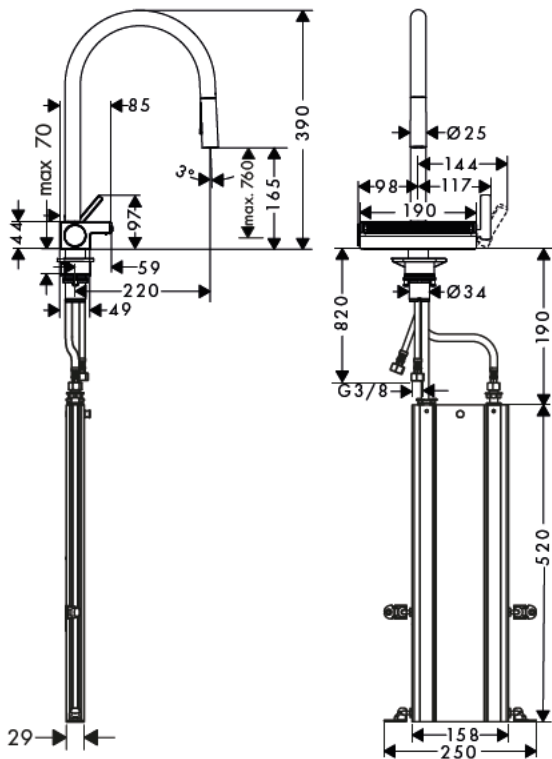



Aquno Select M81 170 3jet sBox

73834XXX

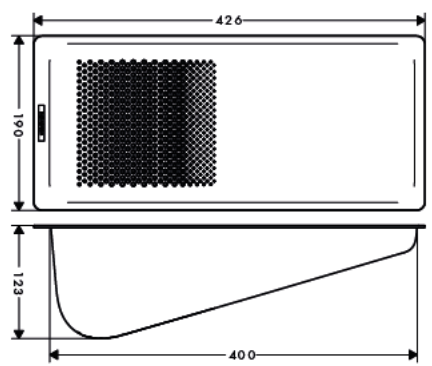
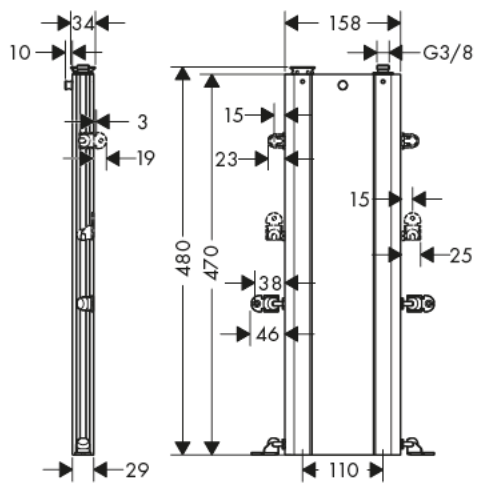
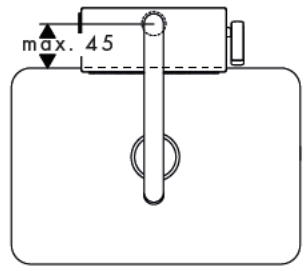
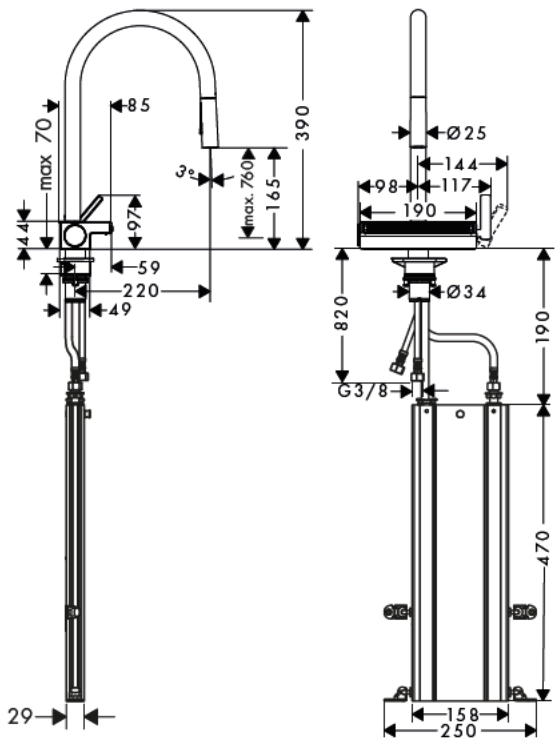



Aquno Select M81 250 2jet sBox

73830XXX

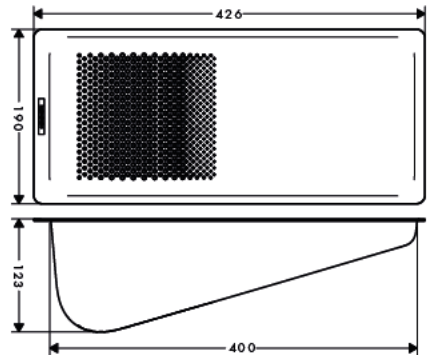
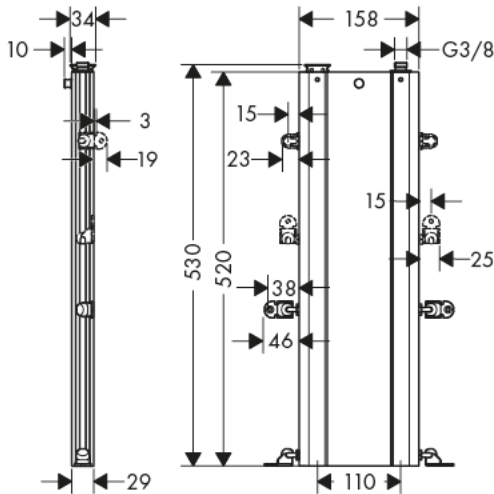
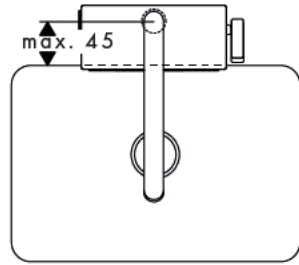
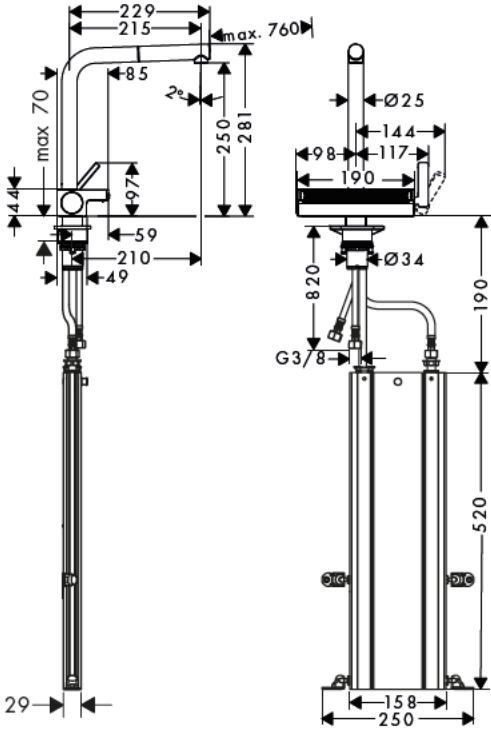



Aquno Select M81 250 2jet sBox

73835XXX

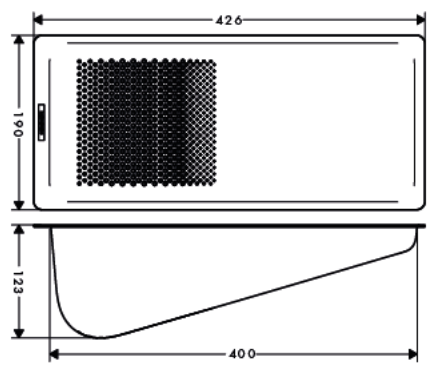
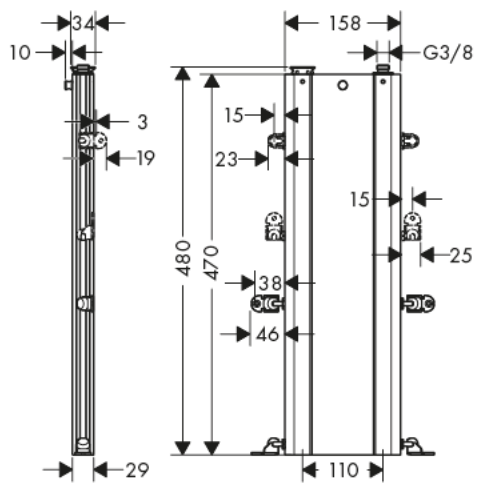
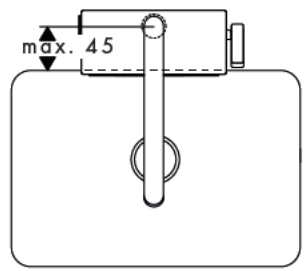
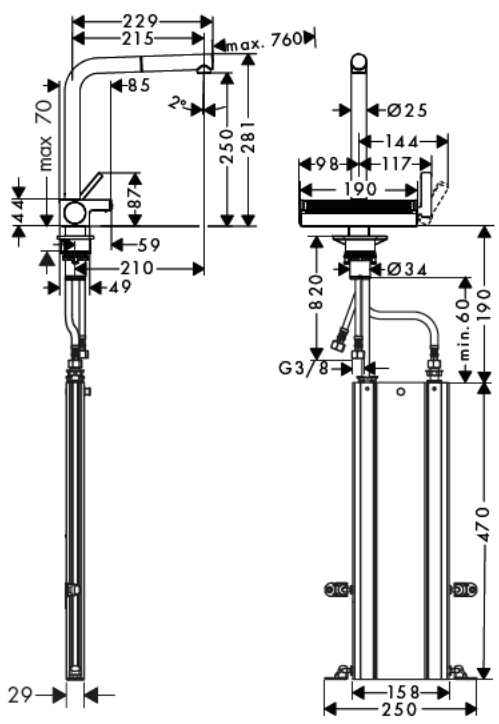



Aquno Select M81 170 3jet sBox

73831XXX / 73834XXX

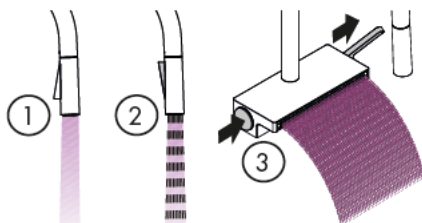
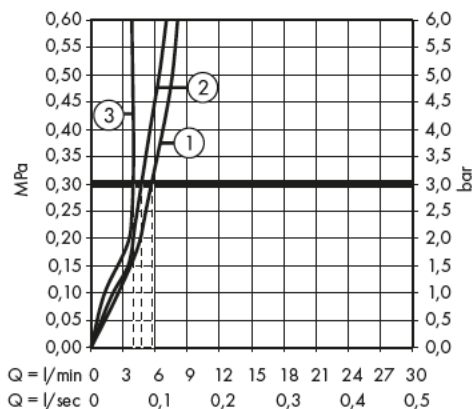

Aquno Select M81 250 2jet sBox

73830XXX / 73835XXX

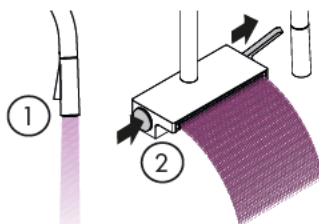
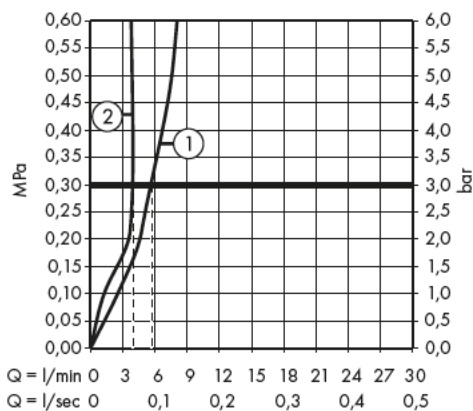



F12
43333000

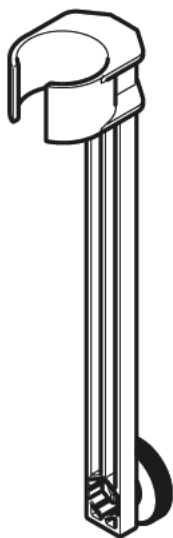

1

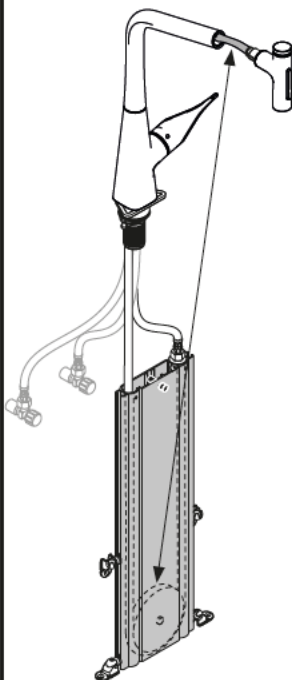

2

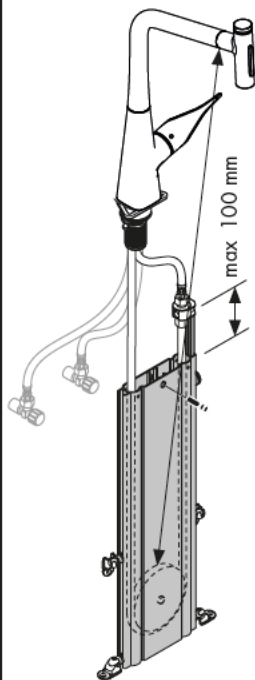



Aquno Select M81 170 3jet sBox

73831XXX / 73834XXX

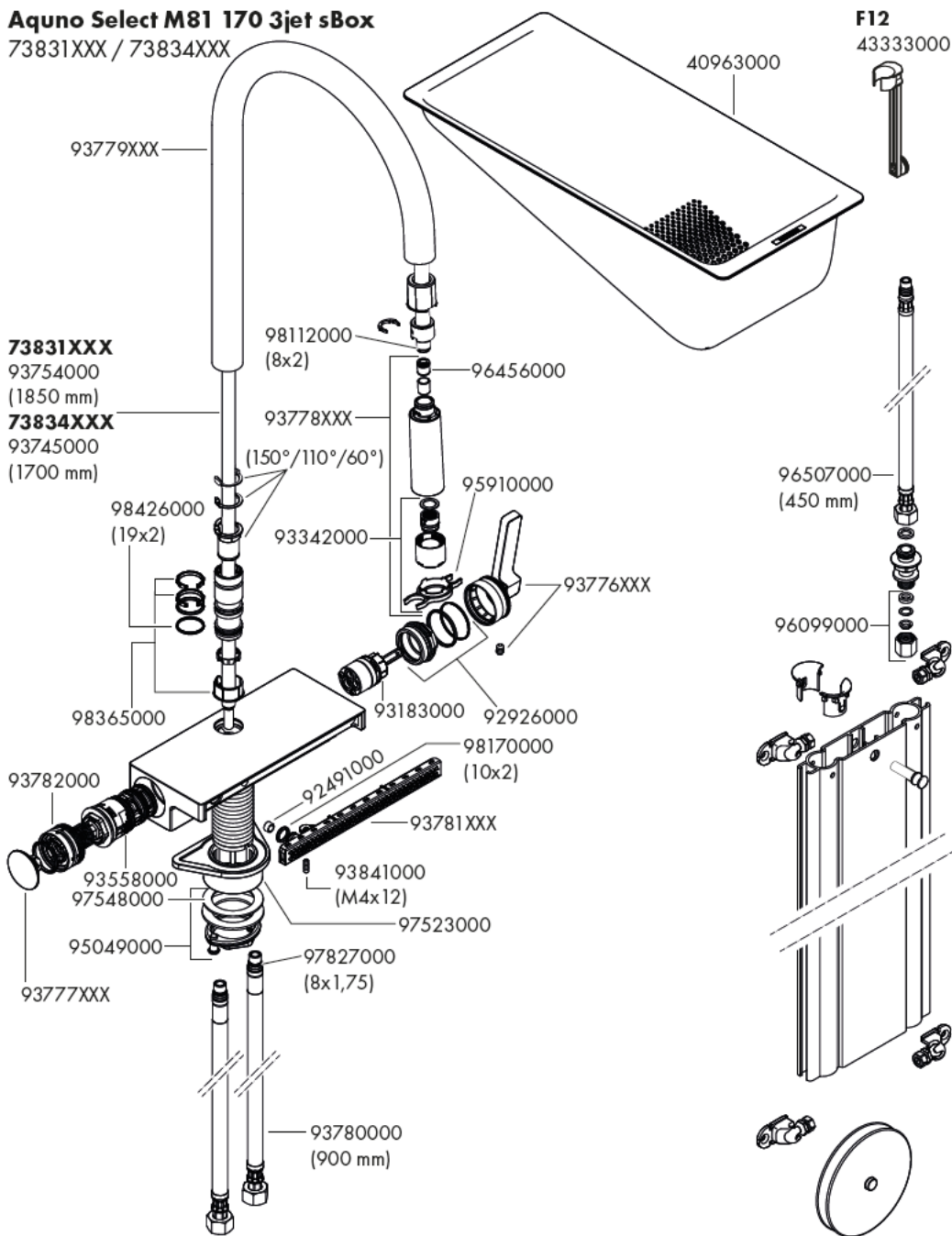

Aquino Select M81 250 2jet sBox
73830XXX / 73835XXX

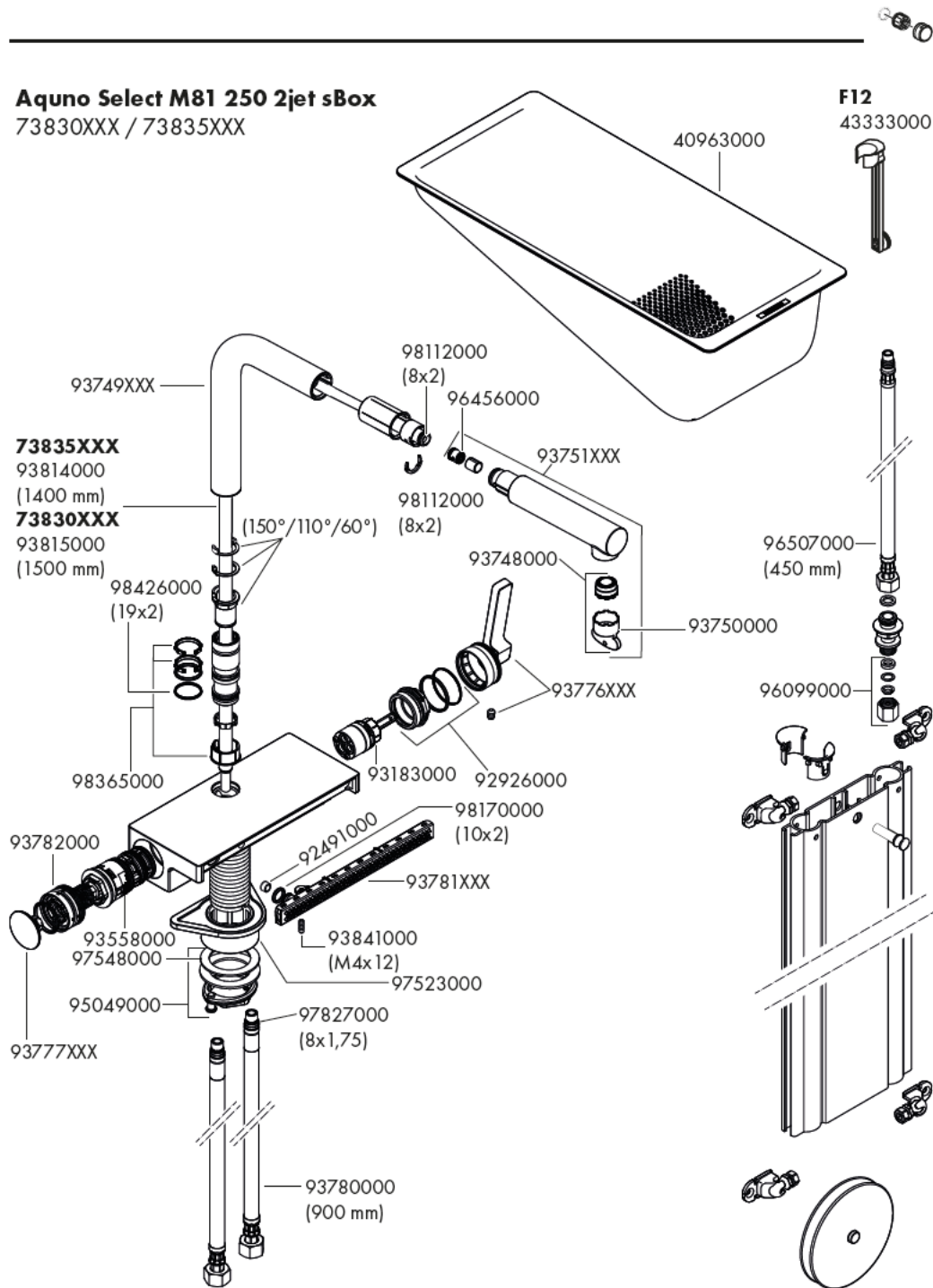

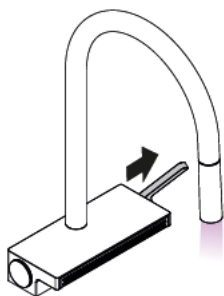

öffnen / ouvert / open / aperto / abierto / open /
 åbne / abrir / otworzyć / otevřít / otvorit / 开 /
 открыть / nyitás / avaaminen / öppna / atidaryti /
 Отваранje / açmak / deschide / ανοικτό / odpreti /
 avage / atvērt / otvoriti / åpne / отварање / hare /
 فتح / 開く

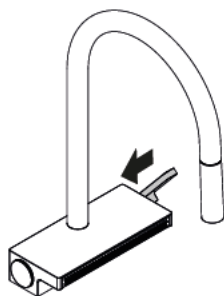

schließen / fermé / close / chiudere / cerrar / sluiten /
 lukke / fechar / zamknąć / zavřít / uzavrieť / 关 /
 закрыть / bezárás / sulkeminen / stänga / uždaryti /
 Затваранje / kapatmak / închide / κλειστό / zapreti /
 sulgege / aizvērt / zatvori / lukke / затваряње /
 mbylle / إغلاق / 閉じる

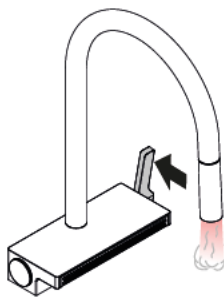

warm / chaud / hot / caldo / caliente / warm / varmt /
 quente / ciepła / teplá / teplá / 热 / горячая / meleg /
 lämmin / varmt / karštas / Vruća voda / sıcak / cald /
 ζεστό / toplo / kuum / karsts / topla / varm / тепло /
 i ngrohtë / ساخن / 温かい

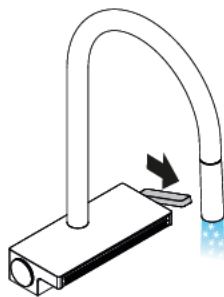

kalt / froid / cold / freddo / frío / koud / koldt / fria /
 zimna / studená / studená / 冷 / холодная / hideg /
 kylmä / kallt / šaltas / Hladno / soğuk / tese / κρύο /
 mrzlo / külm / auksts / hladno / kaldt / студено /
 i ftohtë / بارد / 冷たい

Aquno Select M81 170 3jet sBox 73831XXX / 73834XXX

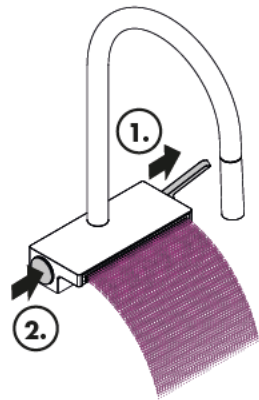
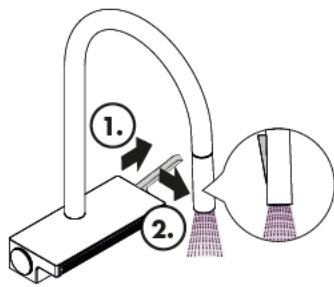
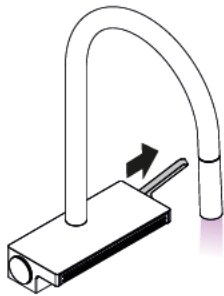

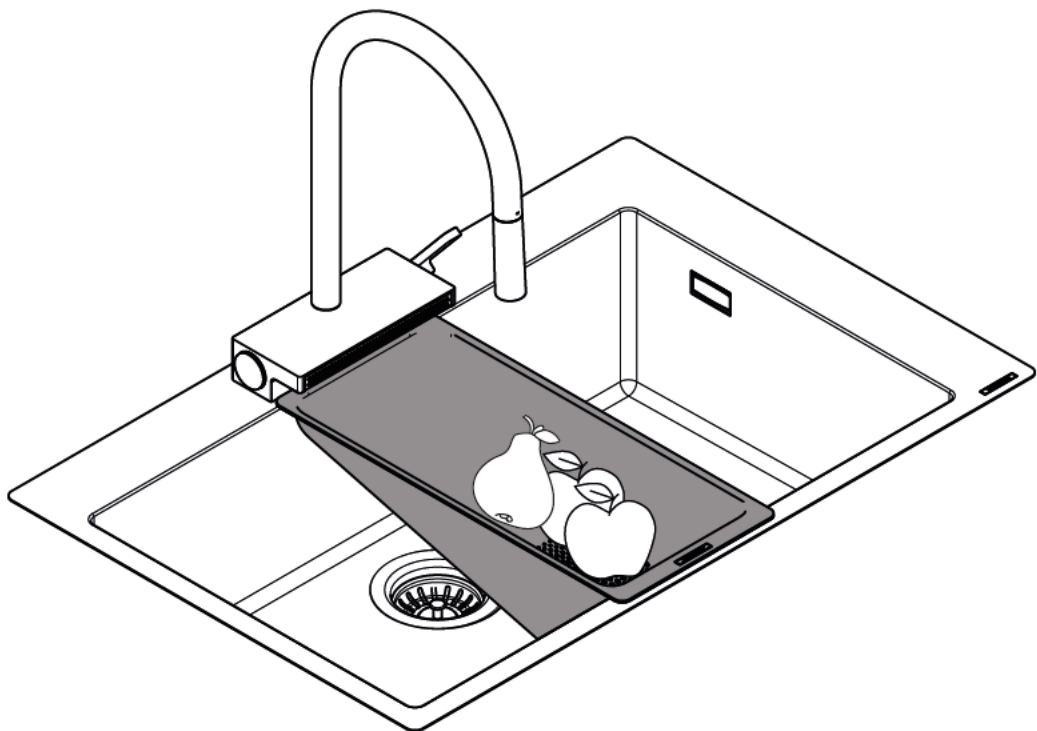

P-IX

VDGW SINTEF NF



ETA



GODKENDT
TIL DRILLEKVVAND



73830XXX P-IX 29857/100 X

73831XXX P-IX 29858/1000 X

73834XXX

73835XXX





- DE** Reinigungsempfehlung / Garantie / Kontakt
- FR** Recommandation pour le nettoyage / Garanties / Contact
- EN** Cleaning recommendation / Warranty / Contact
- IT** Raccomandazione di pulizia / Garanzia / Contatto
- ES** Recomendaciones para la limpieza / Garantía / Contacto
- NL** Aanbevelingen inzake reiniging / Garantie / Contact
- DK** Rensning, anbefaling / Garanti / Kontakt
- PT** Recomendações de limpeza / Garantia / Contacto
- PL** Zalecenie dotyczące pielęgnacji / Gwarancja / Kontakt
- CS** Doporučení k čištění / Záruka / Kontakt
- SK** Odporúčania pre čistenie / Záruka / Kontakt
- ZH** 清洁指南 / 担保 / 接触
- RU** Рекомендации по очистке / Гарантия / Контакты
- FI** Puhdistussuositus / Takuu / Kosketus
- SV** Rengöringsrekommendationer / Garanti / Contacto
- LT** Valymo rekomendacijos / Garantija / Kontaktai
- HR** Preporuke za čišćenje / Garancija / Kontakt
- TR** Temizleme önerisi / Garanti / Temas
- RO** Recomandări pentru curățare / Garanție / Contact
- EL** Σύσταση καθαρισμού / Εγγύηση / επαφή
- SL** Priporočilo za čiščenje / Garancija / Kontakt
- ET** Puhastussuovitused / Garantii / Kontakt
- LV** Tīrīšanas ieteikumi / Garantija / Kontakti
- SR** Preporuke za čišćenje / Garancija / Kontakt
- NO** Anbefaling for rengjøring / Garanti / Kontakt
- BG** Препоръка за почистване / Гаранция / Контакт
- SQ** Këshilla rreth pastrimit / Garancia / Kontakt
- KO** 세정시 권장사항 / 품질보증 / 접촉
- AR** توصيات التنظيف / الضمان (الولايات المتحدة الأمريكية) / اتصال
- HU** Tisztítási tanácsok / Garancia / érintkezés
- JP** お手入れの方法 / 保証について / ご連絡先



[www.hansgrohe.com/
cleaning-recommendation](http://www.hansgrohe.com/cleaning-recommendation)

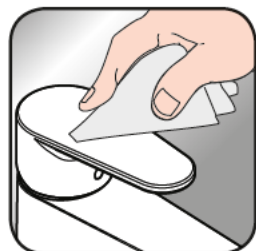

[www.hansgrohe.com/
cleaning-recommendation](http://www.hansgrohe.com/cleaning-recommendation)



[www.hansgrohe.com/
cleaning-recommendation](http://www.hansgrohe.com/cleaning-recommendation)



[www.hansgrohe.com/
cleaning-recommendation](http://www.hansgrohe.com/cleaning-recommendation)

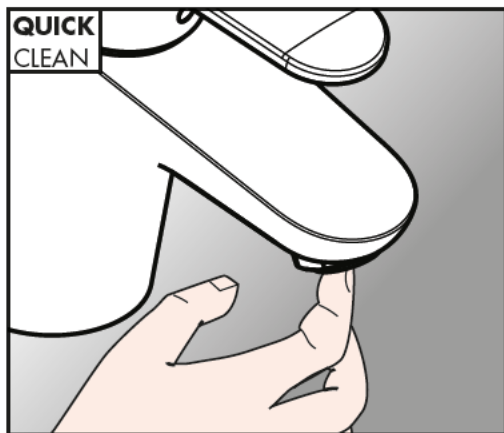

- DE** Einfach sauber: Kalk lässt sich von den Noppen ganz leicht abrubbeln.
- FR** La propreté en toute simplicité: les dépôts formés sur les buses élastiques en silicone s'éliminent par un simple passage de la main.
- EN** Just clean: simply rub over the spray nozzles to remove lime scale.
- IT** Facile da pulire: Il calcare viene eliminato semplicemente dagli ugelli elastici in silicone.
- ES** Fácil aseó: La cal se puede retirar sencillamente frotando con los dedos de las toberas elásticas de silicona.
- NL** Eenvoudig schoon: Kalk kan eenvoudig van de noppen worden gewreven.
- DK** Enkel rengøring: Det er let at fjerne kalkaflejringer fra stråledyserne.
- PT** Simplesmente limpo: o calcário pode ser simplesmente retirado das saiências através de fricção.
- PL** Po prostu czysto: Pęczki można całkiem łatwo oczyścić z kamienia.
- CS** Jednoduše čistě: Vapenné usazeniny můžete z popků snadno odstranit oříháním.
- SK** Jednoducho čistý: Vodný kameň sa dá zo štetín celkom ľahko odstrániť.
- ZH** 清洁: 只需要揉搓花洒表面的出水孔即可去除水垢。
- RU** Простота чистки: известь очень легко стирается с утолщений.
- FI** Yksinkertaisesti puhdas: kalkin voi helposti hieroa irti nypystä.
- SV** Enkelt att göra rent: det är lätt att ta bort kalk från popporna.
- LT** Paprasta švara: kalkės lengvai nugrandomos nuo kilpos.
- HR** Jednostavno čisto: Kamenac se sasvim lako uklanja s izbočina.
- TR** Sadece temiz: Kireç, düğümlerle kolayca ovalanabilir.
- RO** Pur și simplu curat: Calcarul se îndepărtează ușor de pe noduri prin frecare.
- EL** Απλά τέλεια καθαριότητα: Τα αλάτα μπορούν να αφαιρεθούν με μεγάλη ευκολία από τα στόμια.
- SL** Preprosto čisto: arpenec se z lahkoto podrgne z vozličkov.
- ET** Lihtsalt puhas: luoja saab nuppuheldi lihtsalt maha hõõruda.
- LV** Vienkārša tīrīšana: kaļķis no izvirzījumiem ir viegli norubināms.
- SR** Jednostavno čisto: Kamenac se sasvim lako skida sa izbočina.
- NO** Simpelten ren: Ved å gnikke er det lett å fjerne kalk fra nuppene.
- BG** Просто чисто: Варовикът лесно може да се изтърси от удебеленията.
- SQ** Thjesht dhe pastër. Mbetjet gëlqerore mund të hiqen me fërkim të lehtë.
- AR** إنه سهل التنظيف، حيث يسقط الجير بسهولة شديدة من الأجزاء الناتئة
- HU** Egyszerűen tiszta: a vízkő egészen könnyen ledörzsölhető a csomókról.
- JP** 清掃が簡単: カルキは突起部から簡単にこすり落とすことができます。

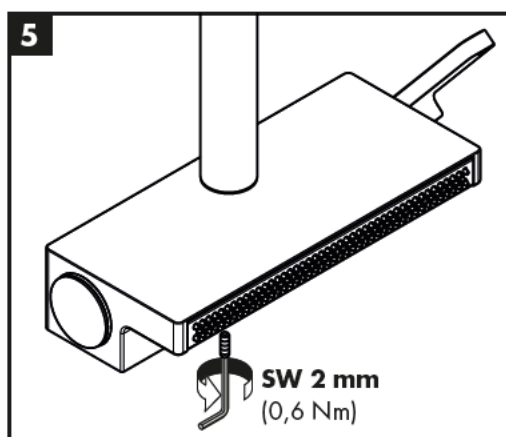
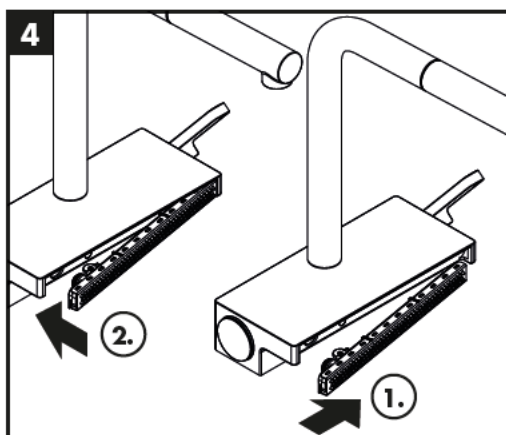
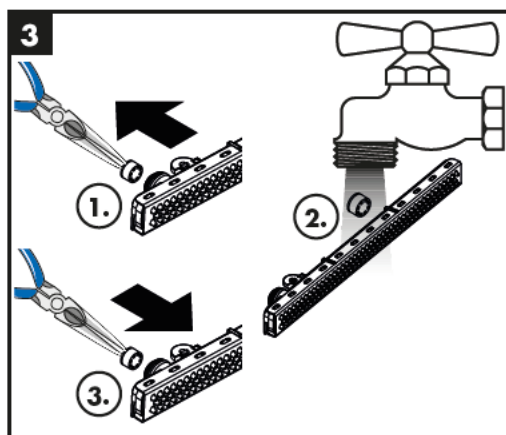
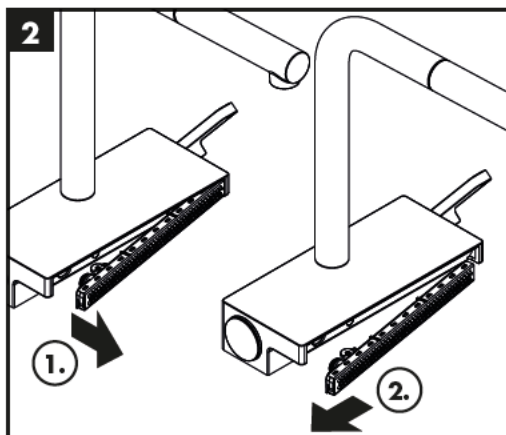
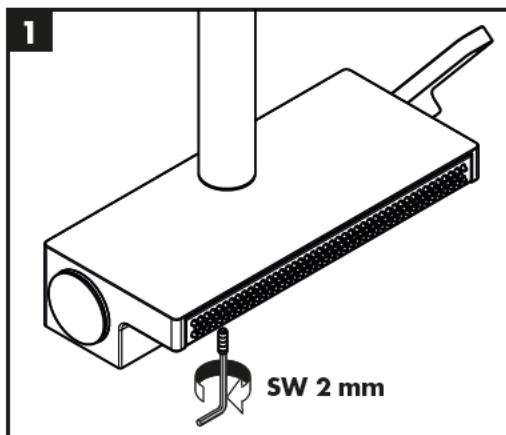

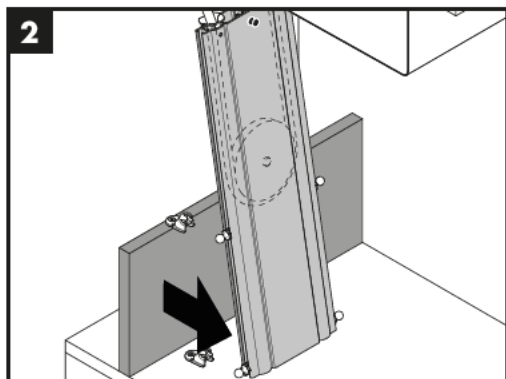
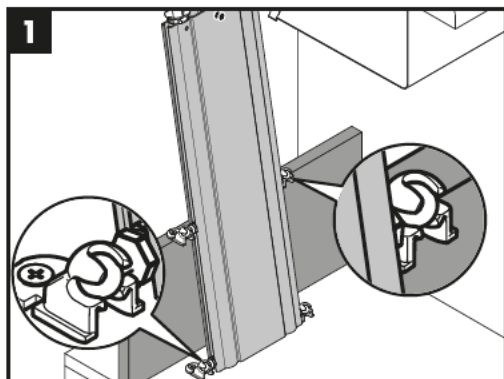
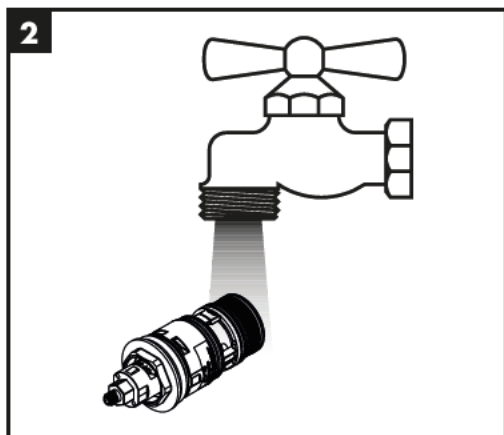
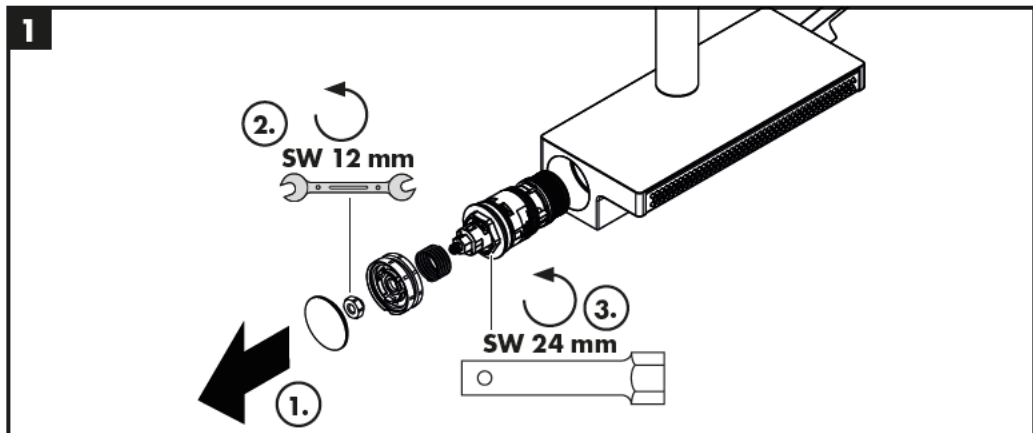

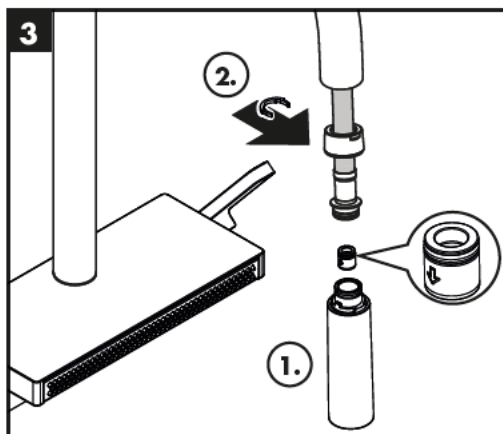
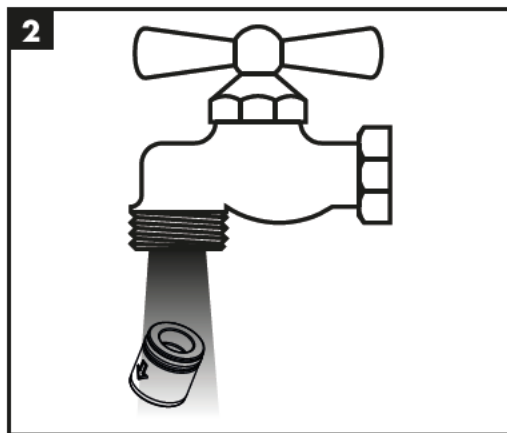
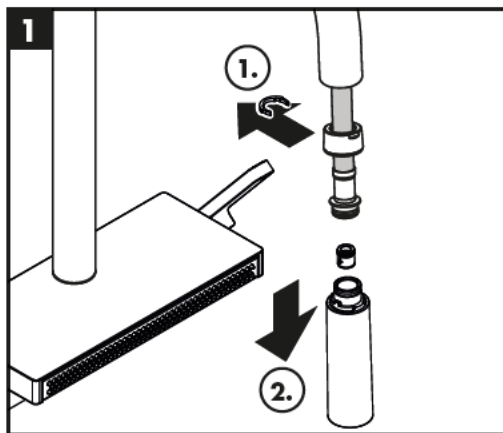

hansgrohe

Hansgrohe · Avestraße 5 · 9 · D-77761 Schlittach · Telefon +49 (0) 78 36/51-1282 · Telefax +49 (0) 7836/511440
E-Mail: Info@hansgrohe.com · Internet: www.hansgrohe.com

08/2020
9.071.6301