

Installation Guide

Smart Cube Energy Controller Home

Single-phase System



Copyright Notice

- Copyright© 2024 Qingdao NaHui Intelligent Technologies Co.,Ltd. All Rights Reserved.
- Description in this document may contain predictive statements regarding financial and operating results, product portfolio, new technology, configurations and features of product. Several factors could cause difference between actual results and those expressed or implied in the predictive statements. Therefore, description in this document is provided for reference purpose only and constitutes neither an offer nor an acceptance. Qingdao NaHui Intelligent Technology Co., Ltd. may change the information at any time without notice.

Contents

Overview	5
Chapter 1 General Requirements.	4
Chapter 2 Personnel Requirements	6
Chapter 3 Handling and Transportation Requirements	6
3.1 Routine Requirements	6
3.2 BatteryPack	7
Chapter 4 Storage Requirements	8
Chapter 5 Operating Requirements	10
5.1 Routine Requirements	10
5.2 Equipment Installation	11
5.3 Cable Connection	12
5.4 Equipment Maintenance and Replacement	12
Chapter 6 Introduction to Single-phase System	13
6.1 Introduction to Networking	13
6.2 Appearance and Dimensions	16
6.3 Port Descriptions	16
Chapter 7 Pre-installation	17
Chapter 8. Site Selection Requirements	19
Chapter 8 Installation of inverter and battery pack	21
8.1 Floor Installation	21
8.2 Wall Installation	30
Chapter 10 Cable Connection and Component Installationn	32
10.1 Recommended Cabling installation	32
10.2 Protective Ground Cable of Inverter	33

Contents

9.3 AC Output Cable of Inverter	32
9.4 RS485 Signal Cable	34
9.4.1 RS485 Signal Cable of inverter	35
9.5 RJ45 Cable of Inverter	35
9.6 CommMod Installation	38
9.7 WLAN antenna stick Installation	38
9.7 DC input cable of Inverter	39
Chapter 11 Post–installation Check	41
Chapter 12 Installation of the Decorative Cover	42
Chapter 13. Equipment Power–On	42
Chapter 14 Downloading “Haier Smart Cube” App and Creating New System	45

Overview

Introduction

- This document describes the precautions for installing, operating, and maintaining of the devices in the Energy Controller Home.



Target readers

This document is intended for:

- Trained and qualified installation personnel
- Technical support engineer

Sign Definition

- The following signs may be used in the document to indicate security precautions or key information. Before installation and operation, familiarize yourself with signs and their definitions.

Signs	Definition
 Danger	Danger. Failure to comply may result in death or serious personal injury.
 Warning	Danger. Failure to comply may result in serious personal injury or property damage.
 Caution	Caution. Failure to comply may result in equipment damage and property loss.
Tips	Important or key information, and supplementary operation tips.

Chapter 1 General Requirements

Before installing, operating, and maintaining the equipment, familiarize yourself with this document.

The "Danger", "Warning", and "Caution" items described in this manual are only supplementary to all precautions.

The Company shall not be liable for equipment damage or property loss caused by the following reasons:

- The installation environment does not meet international, national, or regional standards.
- Failure to comply with local laws regulations, and regulations when transporting, installing, operating, or maintaining the equipment.
- The installation area does not meet the requirements of the equipment.
- Cables and tools used do not meet international, national, or regional standards.
- Damage caused by storage conditions that do not meet equipment requirements.
- Failure to follow the instructions and precautions in this document.
- Failure to handle the equipment with care or violent installation may result in equipment damage and liquid leakage and pose a risk of fire or explosion hazards.
- Failure to follow the warning labels on equipment or tools.
- Negligent, improper operation or intentional damage.
- Battery pack capacity loss or irreversible damage caused by failure to timely charge the equipment due to customer reasons.
- Damage caused by the customer or the third party company changing the use of our company's equipment (such as mixing our company's battery pack with other battery pack, using our company's battery pack with other brands of inverters or converters, etc.).
- The equipment is damaged because the customer or a third-party company fails to use the accessories supplied with the packing box or purchase and install accessories of the same specification.
- Equipment damage caused by improper operations such as disassembling, replacing, or modifying the software code without authorization.
- Equipment damage caused by force majeure (such as war, earthquake, fire, storm, lightning, flood, debris flow, etc.).

- Damage caused by the failure of the natural environment or external power parameters to meet the standard requirements of the equipment during actual operation (for example, the actual operating temperature of the equipment is too high or too low).
- The equipment was stolen.
- The equipment is damaged after the warranty period.

Chapter 2 Personnel Requirements

The personnel responsible for installation and maintenance of the equipment must receive strict training and get relevant certificates, be familiar with local laws, regulations, and related standards, understand the structure and working principles of the power generation system, understand various safety precautions, master the correct operation methods, and possess the operation qualifications required by the local country.

Chapter 3 Handling and Transportation Requirements

3.1 Routine Requirements

- Wear personal protective equipment, such as protective gloves and safety shoes, when moving equipment.
- Select a proper transport mode based on the weight of the equipment.
- Carry the equipment in the direction specified on the package. Do not tilt or invert the equipment.
- The incline angle of the equipment belt package shall be no more than 15° , and the incline angle after unpacking shall be no more than 10° . If more than one person is moving the equipment, consider the height of the person moving the equipment to ensure stability.
- To avoid injury, lift or move the equipment slowly.
- When using a forklift, place the fork knife in the middle of the equipment, and bind the fork knife according to the actual situation. When moving, a special person should take care of it. No movement under the fork knife.
- Place the equipment according to the stacking requirements on the package. Stacking requires strapping and fastening.
- The equipment should be placed firmly, and inverting or tilting is prohibited during transportation.
- It is advisable to use protected means of transport. The equipment is prohibited from being subjected to rain, water immersion, etc.

3.2 Battery Pack

Caution

- Do not use the equipment if it has been dropped, subjected to mechanical shock, submerged in water, or otherwise exposed to water.
- If the equipment has been exposed to rain or snow, please have it evaluated by a professional before using it again.

Tips

The equipment belongs to Class 9 Dangerous Goods and has been approved by UN38.3 (UN38.3: Section 38.3 of the sixth Revised Edition of the Recommendations on the Transport of Dangerous Goods: Section 38.3 of the sixth revised edition of the recommendations on the transport of dangerous goods: Manual of Tests and Criteria) and SN/T 0370.2-2009 "Inspection Procedures for Packaging of Dangerous Goods for Export Part 2: Performance Inspection".

Loading and Unloading Requirements:

- Load and unload the equipment according to local laws, regulations, and industry standards. Violent loading and unloading are prohibited. Handle the equipment with care; otherwise, it may break, leak, fire, or explode.

Prior to Transportation:

- Before transportation, ensure that the package is intact and no odor, smoke, or fire occurs. Otherwise, do not transport the equipment.
- Before transportation, ensure that the equipment are securely placed and protected from moisture.
- It is forbidden to place the equipment in the same vehicle or container with common articles such as food, medicine and animal feed.
- If the equipment must be shipped with common goods, please take the following measures:
 - ▶ The space between common articles and equipment is ≥ 0.8 m.
 - ▶ Use isolators as high as the equipment package for isolation.
- Never arrange the equipment in the same vehicle or container with flammable, explosive or corrosive materials.

During Transportation:

- Please comply with international regulations on the transport of dangerous goods and meet the requirements of the local transport regulatory authorities of the countries of shipment, route, and destination.
- It is prohibited to transport by rail and by air.
- For transport by sea, please observe the transport requirements of the International Maritime Dangerous Goods CODE (IMDG CODE).
- For land transport, please follow the requirements of the European Agreement Concerning the International Carriage of Dangerous Goods by Road (ADR) or the Regulations Concerning Road Transportation of Dangerous Goods (JT/T 617).
- It is recommended to transport by sea or choose a road with good road conditions, and minimize turbulence or tilt in the process of transport.

Chapter 4 Storage Requirements

- The storage location must comply with local laws and regulations.
- Do not unpack the storage equipment.
- Do not store battery packs with other items. Fire fighting facilities such as fire extinguishers that meet requirements must be placed at the battery pack storage site.
- Do not expose the equipment to direct sunlight or to wet, dewy, dirty, rainy, flammable, explosive or corrosive environments.
- The storage location should be well protected against insects and rodents.
- When storing the equipment, place it according to the storage requirements on the package.
- During storage, periodically record the temperature and humidity of the storage environment.
 - ▶ Storage temperature: -25°C to 60°C , and 20°C to 30°C is recommended.
 - ▶ Relative humidity: 5% to 95% RH. Do not install the battery pack if the battery pack interface is moist and dewy.
- Before storing the battery pack, ensure that the capacity of the battery pack is $40\% \pm 5\%$ SOC.
- When storing the battery pack, the warehouse manager needs to count and report the inventory status monthly. When the recharge period is approaching, please arrange to recharge in time.

Storage temperature requirement	Actual storage temperature	Recharge period
-25°C < T ≤ 60°C	T ≤ -25°C	Not allowed
	-25°C < T ≤ 25°C	15 months
	25°C < T ≤ 35°C	9 months
	35°C < T ≤ 60°C	6 months
	60°C < T	Not allowed

- The storage time of battery packs is calculated from the shipping time on the outer packaging. After the battery is properly charged, update the latest charging time (YYYY-MM-DD is recommended).
- It is not recommended to store battery packs beyond the recommended storage period. After first 12 months at the recommended storage temperature, the irreversible capacity loss is 3% to 10%. If battery packs are stored beyond the expiration date, expiry date, they should be checked and tested by qualified personnel before use.
- Please follow the "first-in, first-out" principle when shipping the equipment.

Chapter 5 Operating Requirements

5.1 Routine Requirements

Danger

High voltage, danger:

- Live operation of the equipment (including but not limited to installation, wiring, replacement, etc.) is prohibited.
- Do not touch the battery pack plug-in with sharp objects.
- Do not operate the equipment in bad weather (including but not limited to thunder, rain, snow, typhoon, etc.).
- Do not clean or soak the equipment with water, alcohol, or oil to avoid power leakage or battery pack leakage.
- Do not hit, drag, or step on the equipment.
- Check the equipment for damage before operating it. Do not perform this operation if there is any abnormality (for example, deformed appearance or strange smell)
- When operating the equipment, wear protective equipment such as insulation gloves, shoes, and safety helmets. Conductive ornaments such as metal bracelets, rings and necklaces are prohibited.
- Use insulation tools when installing and connecting cables.
- Devices that need to be grounded are permanently connected to the protection ground. When connecting cables, connect the ground cable first. Before replacement of any equipment, remove the ground cable at last.
- Before touching the terminal, measure the voltage of the contact point to ensure that there is no danger of electric shock.
- Do not drop any foreign objects into the equipment when operating it.

Caution

- If scratches appear on the equipment's surface, repair the paint in time. Rust and other equipment damage caused by failure to repair paint in a timely manner is not covered by our warranty.

5.2 Equipment Installation

Warning

- When handling the equipment, be prepared to support the load in order to avoid slips and injuries.
- Do not use the battery pack if it has been dropped or subjected to mechanical shock.

Ladder Safety

- Do not use ladders without training or instruction.
- Do not use unqualified ladders (including but not limited to damaged, broken, deformed, and temporary ladders).
- Do not use a ladder that does not meet the load-bearing requirements.
- Use wooden or fiberglass ladders when there is a possibility of electrical work at height.
- When an extension ladder is used, the inclination of the ladder is 60° to 70°.
- When working on a ladder, do not throw objects from height.
- When working on a ladder, it is recommended that another person supervises the operation.
- Lock the door when using the ladder at the entrance of the passageway.

Drilling Safety

- Do not drill holes on the equipment.
- Wear safety goggles and protective gloves when drilling holes.
- Do not place the equipment near the drilling position to prevent debris from falling into the equipment.
- After drilling holes, clean them in time.

5.3 Cable Connection

Danger

- Before connecting cables, ensure that the equipment is not damaged.
 - Before connecting or removing cables, ensure that the front and rear switches of the equipment and its own switches are disconnected.
-
- Do not intertwine or cross cables. You are advised to bundle cables by category.
 - Do not use cables whose insulation layer is damaged, and do not have sharp edges or burrs in the holes where cables pass through.
 - Keep cables away from heat sources to prevent cable aging in a high temperature environment.
 - The lower the ambient temperature is, the more brittle the plastic cable skin will be. To prevent skin cracking during installation, install the cable at a temperature higher than 0°C and handle the cable with caution. If cables are stored in an environment below 0°C for a long time, move them to an environment above 0°C for at least 24 hours before using them.

5.4 Equipment Maintenance and Replacement

- Before maintaining or replacing the equipment, power off the equipment and wait for a sufficient period of time according to the delay label on the equipment. Power on the equipment only after the fault is completely rectified or the replacement is complete.
- Battery energy storage systems have high fire risk, and faulty battery packs may release flammable and toxic gases. Battery pack replacement can only be performed or supervised by professionals who are familiar with the preventive measures.
- When replacing the battery pack, use the battery pack of our company. Do not mix batteries of other brands.
- When the battery pack is faulty, the surface temperature may be too high. Do not touch it with your bare hands.
- Do not store faulty battery packs in flammable or explosive environments, and do not allow non-professionals to approach them.
- During storage of faulty battery packs, monitor them periodically to ensure that no electrolyte leakage, heat, or flame occurs.

⚠ Caution

- Trained or experienced electrical personnel are required to operate the equipment.
- Operators should be familiar with national/regional laws, regulations and standards, the structure and working principle of relevant systems.
- Please read carefully the operating requirements and precautions in this document and "Important Notice" before operating. Failure to do so may result in damage to the equipment that is not covered by the warranty.
- Please consult with the owner for expansion requirements (for example, adding battery packs) before operating. If any, please reserve necessary expansion space and cable length during installation.

Chapter 6 Introduction to Single-phase System

6.1 Introduction to Networking

Backup networking

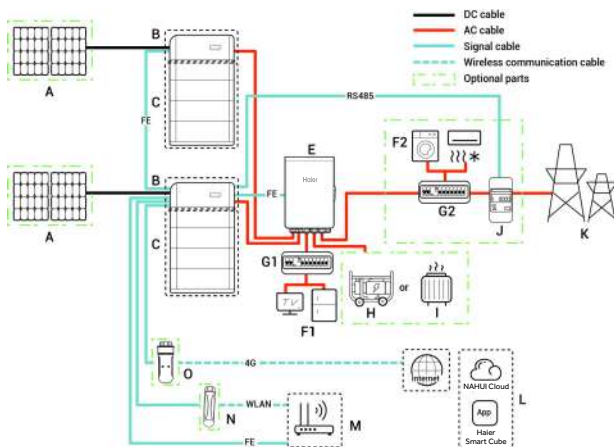

Non-backup networking

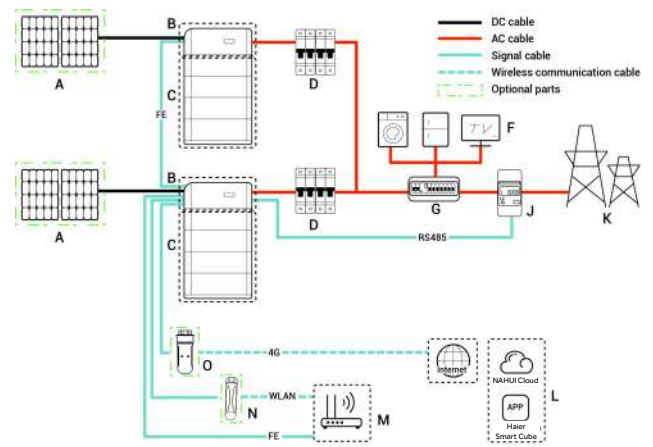

Tips

It is recommended to use FE and WLAN for communication with inverter. CommMod users must top up their own 4G data plan after a period of 2 years.

Code	Equipment/component	Model/version	Function specification
A	PV module	–	–
B	Energy Controller	HH1P-3K/3.6K/4K/4.6K/5K/6K-A	Inverter; it can be used in photovoltaic energy storage scenarios and needs to be used together with PV modules and Battery.
C	Battery	HBP-5.0/8.0-A	Battery pack; it can store electric energy.
D	AC switch	–	The rated voltage of the AC switch connected to each inverter should be ≥ 240 Va.c., and the rated current is recommended: <ul style="list-style-type: none"> •HH1P-(3K-4K)-A: The rated current is 25 A. •HH1P-(4.6K-6K)-A: The rated current is 40 A.
E	Gateway	HG-SS	It's applicable for PV storage and pure storage applications to facilitate data acquisition and monitoring, off-grid backup power switching, diesel generator control, energy management; it must be used with Battery and inverter. Gateway is a must-have for backup networking; for partial backup power and zero-power grid connection control networking, the Gateway and power sensor must be arranged.
F	Electric equipment	–	In the backup networking, F1 is the electric equipment for backup; F2 is non-backup the electric equipment.
G	Distribution panel	–	<ul style="list-style-type: none"> • In the backup networking, G1 is the backup panel, requiring a residual current device with rated residual operating current of 30 mA; G2 is the non-backup Distribution panel. • The rated voltage of the AC switch of the distribution panel should be not less than 240 Va.c., And the rated current is recommended: that is, not less than the maximum output current of an inverter the number of inverters in parallel connection 1.25[1].

Code	Equipment/component	Model/version	Function specification
Y(T- x ((P (xyz" (z (± (≤ 2 ≥(± 2 } (x x - (-zx ("(x } ≥(-x(x Wk x ((} (x(≥ x(x - (y (fm x ² (x }) - x (
[S y ≤ (x}	(S y ≤ (x} (-z ≤} (x x (≥ ≥ - (x x (x } ((kx (≥ x ≥ (± (x(≥ - (x x (x } (; F n 9G (P8
](f ((Yc i 7P 2 Tc AB; c e TRI i 3 Yc i 7Sk; A: P(2 Tc ; A: Sk(C: ≥ P3	Tx x(xz - (± (z z - (- (xy ≤ ((z z - d ((- (} } (± (x ≥ } (xyz" (" - 2
a	f (z (((
b	P (Yx- (i ≥ x (S y (P } } (E8 ((e i ; AB (x } (
c	h ((k (y (} (± (VU9n bPd(z ≥ ≥ zx -
d	P x((k (y (} (± (n bPd(z ≥ ≥ zx -
e(S ≥ ≥ zx - (≥ } ≤ (YS7I CW	k (y (} (± (CM(z ≥ ≥ zx -

Tips

For further information on the installation and wiring of Gateway, refer to the HG-SS Installation Guide .

6.2 Appearance and Dimensions

Inverter and battery pack

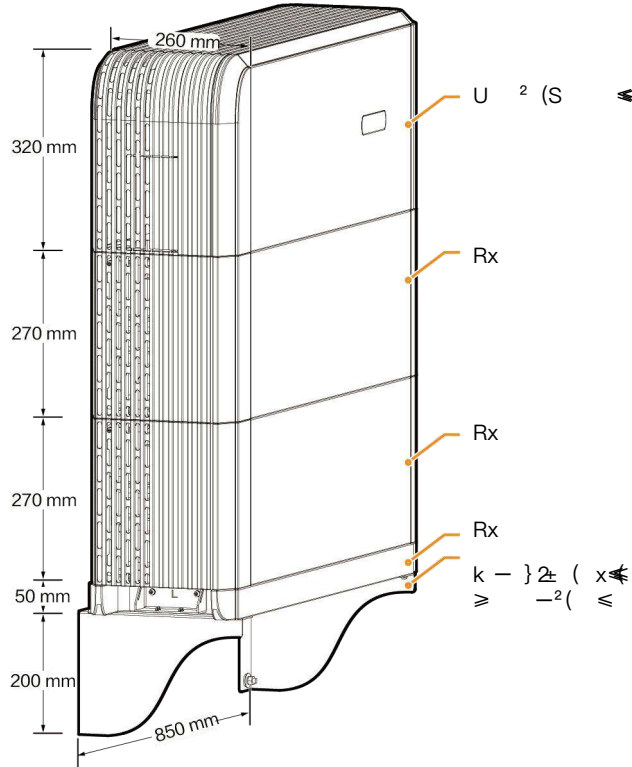

6.3 Port Descriptions

Energy Controller Left View

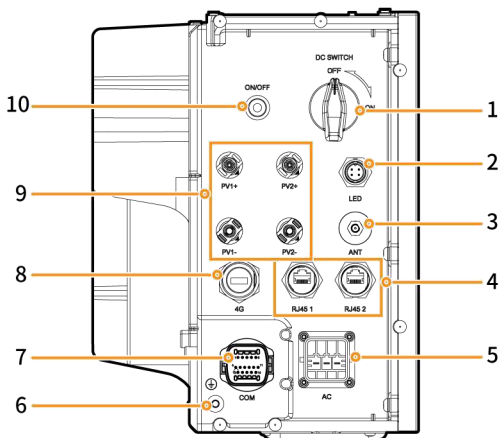

S/N	Name	Marking
1	DC switch	DC SWITCH
2	Decorative cover light strip connector	LED
3	Antenna interface	ANT
4	Cable interface	RJ45 1/ RJ45 2
5	AC output interface	AC
6	Ground screw	-
7	Communication interface	COM
8	CommMod interface	4G
9	DC input interface	PV1+/PV2+ / PV1-/PV2-
10	Switch button	ON/OFF

Chapter 7. Pre-installation Check

- Check whether the components are entirely supplied against the packing list and whether the appearance is in good condition. For any problem, contact your sales representative.
- Check personal protective equipment and installation tools to ensure that they are complete; If not, please make them up.
- Check and ensure the completeness of personal protective equipment and installation tools; replenish if necessary.

Protective equipment



Installation tool

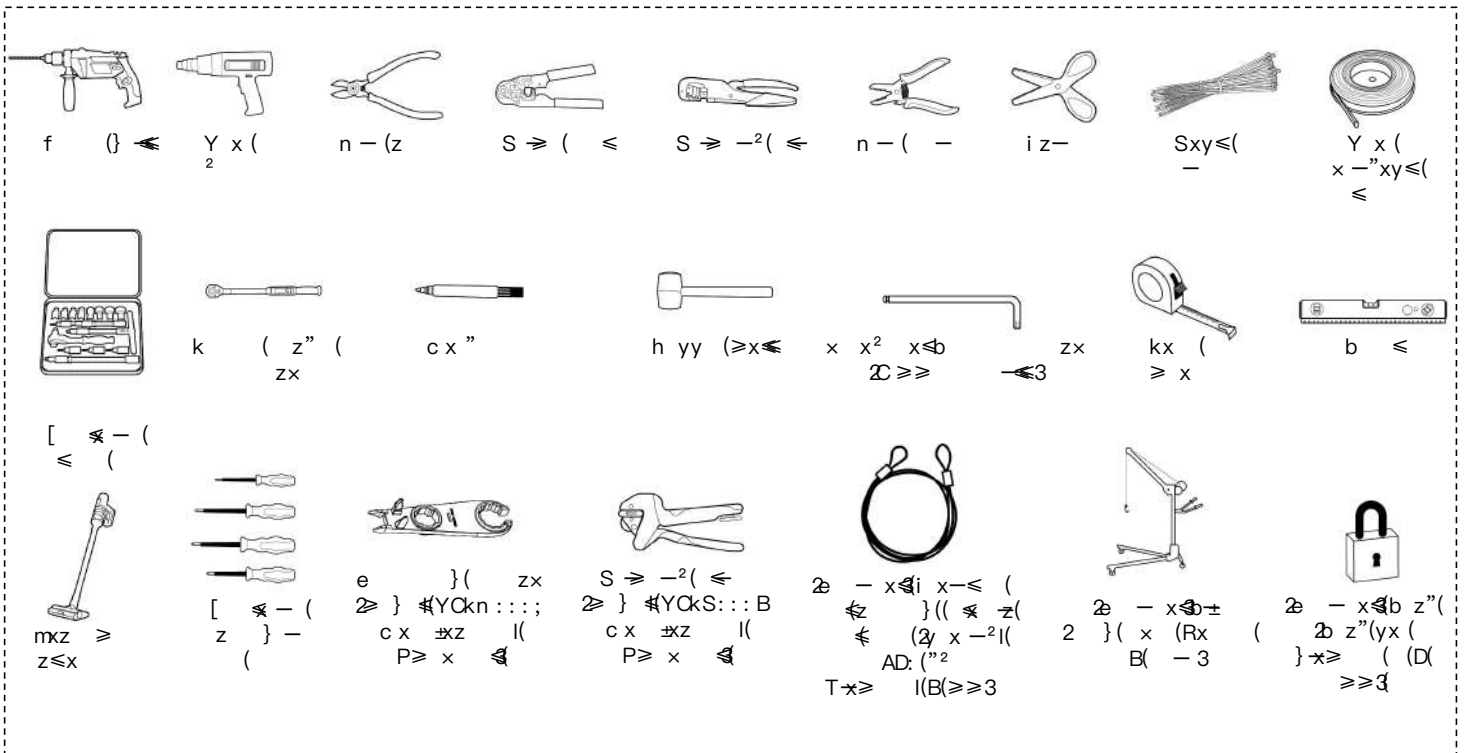

Caution

- The specifications of the Installer-provided cable must comply with the cable regulations and standards of the country or region standards.
- L, N and PE should be connected to other equipment in sequence without mixing.

Installer-provided cable

Code	Cable name	Recommended specifications
;(f z - (2 } (zxy≤(±- (x -2(e } (-2≤(z (z (zxy≤(S z - x x(±z (z } z I(C E(≥≥ J e } x≥ I(C G(≥≥(
A(PS(zxy≤(e } (x 7z (z (zxy≤(200d6f U3 S z - x x(±z (z } z I(C E(≥≥ J e } x≥ I(B A;(≥≥(
B(hi OGD(-2 x xzxy≤(e } (x- } (- } (x- S z - x x(±z (z } z I(:D :FD(≥≥ (≥ ≤-z (±≤ y≤(z } z Gk y (≥-x } }3(:D ;(≥≥ (2 -2≤ x } (xx)(z } z G (y (≥-x } }3(e } x≥ I(CD E(≥≥(Sxy≤(≤ 2 x(;:: (≥ Rx } (x I(HE:: (y
C	h]CD(" (zxy≤(e } (-2x z } z (x- } (- - } (x-(zxy≤(S z - x x(±z (z } z I(: 8B : 8A(≥≥ J e } x≥ I(C F(≥≥(i -2≤(zxy≤(≤ 2 x(;:: (≥rAt
D(TS(- (zxy≤(±-	e } (x ≤-z(zxy≤(S z - x x(±z (z } z I(C E(≥≥ J e } x≥ I(D(H(≥≥(

Note [2]: The cable length should be limited for good communication. Too long cable degrades the communication effect. FE communication distance: ≤ 100 m.

Tips

Recommended specifications for cables connecting power sensors to Distribution panel and to the grid, as well as step-by-step instructions for wiring, can be found in the accompanying documentation for each respective model.

Mounting surface

- The mounting surface must be flat and level.
- The mounting surface must be strong enough to support the weight of the unit.
- The mounting surface must be free of moisture, oil, and other contaminants.
- The mounting surface must be made of a material that is compatible with the mounting brackets.

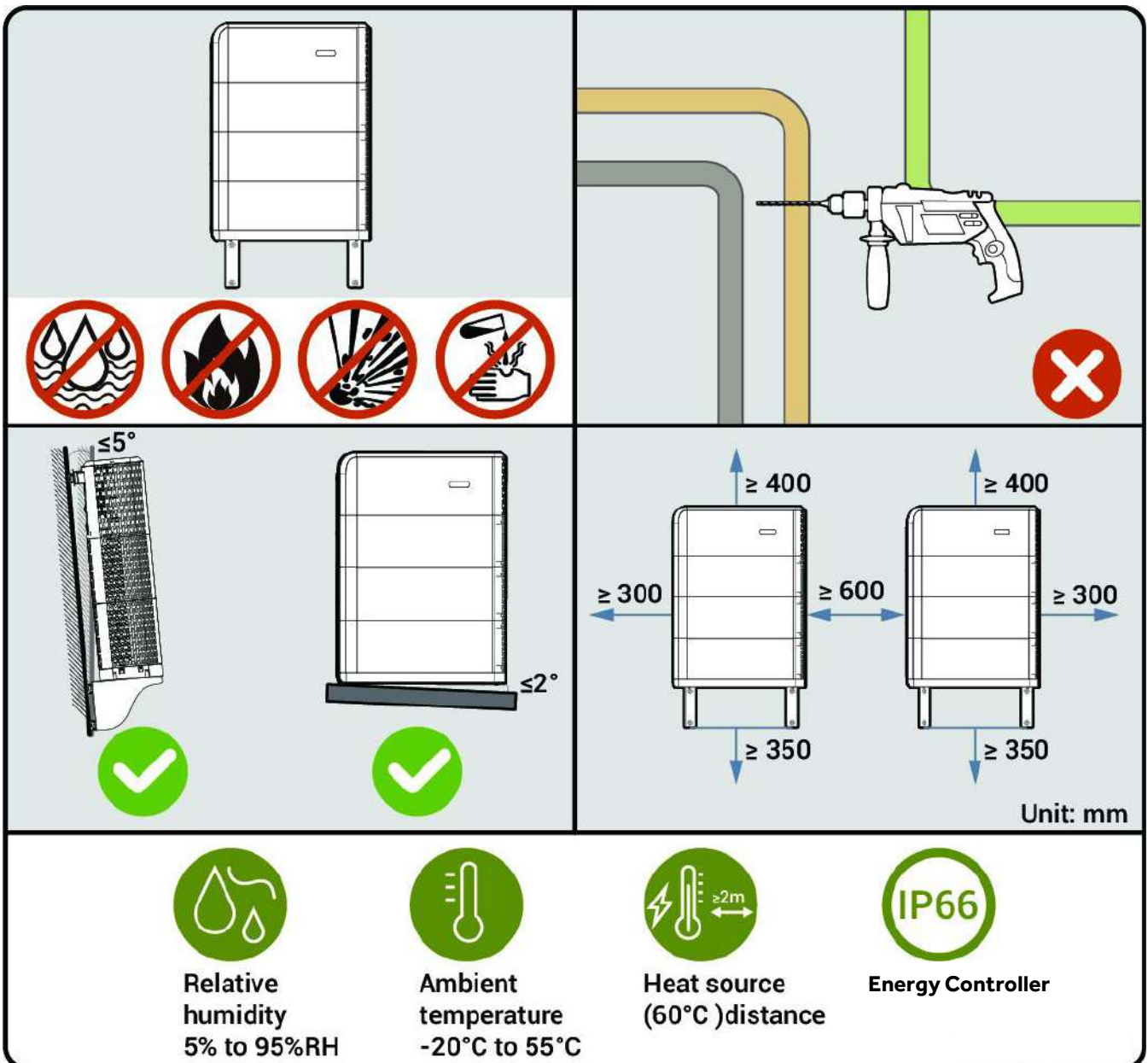

Chapter 9. Installation of inverter and battery pack

Tips

- Up to six batteries are supported for floor installation and up to two for wall installation.
- When installing three or more batteries on the floor, use Lift.
- Multiple batteries can be installed onsite based on the actual configuration.
- If the floor is prone to stagnant water, please set up a waterproofing platform or install it on the wall.
- The equipment is heavy, do not slip off when handling the equipment to avoid the equipment falling and injuring the operator.
- Battery is forbidden to be used after falling, please buy a new one.
- Do not drag the equipment during installation.

9.1 Floor Installation

L If the bubble level is not centered, use a leveling pad to adjust.

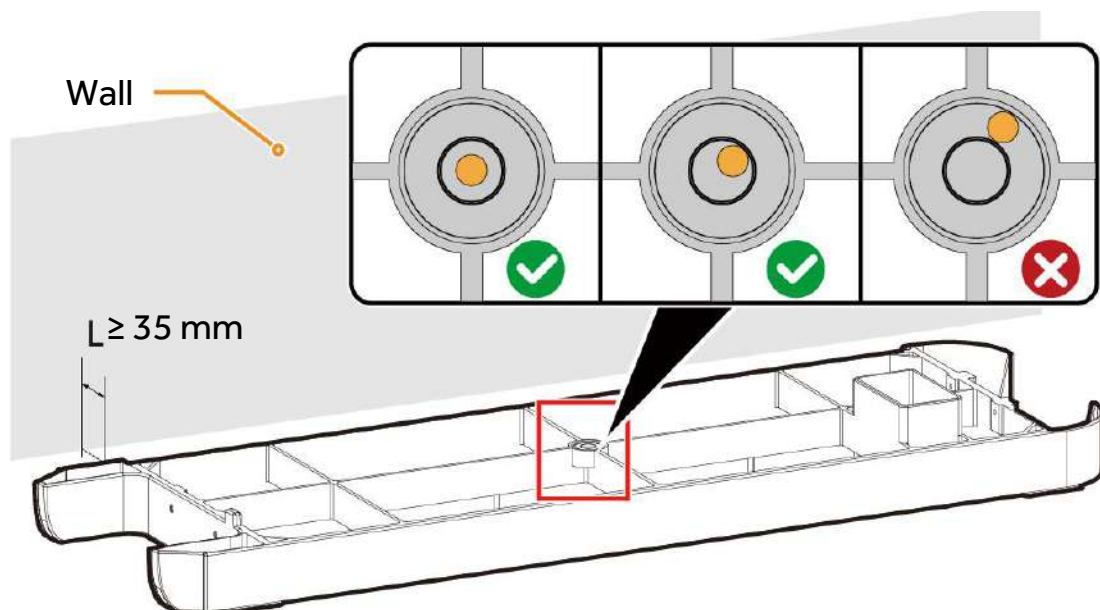

N There are two installation methods for the Base. Please refer to the actual product received for detailed instructions.

Option 1:

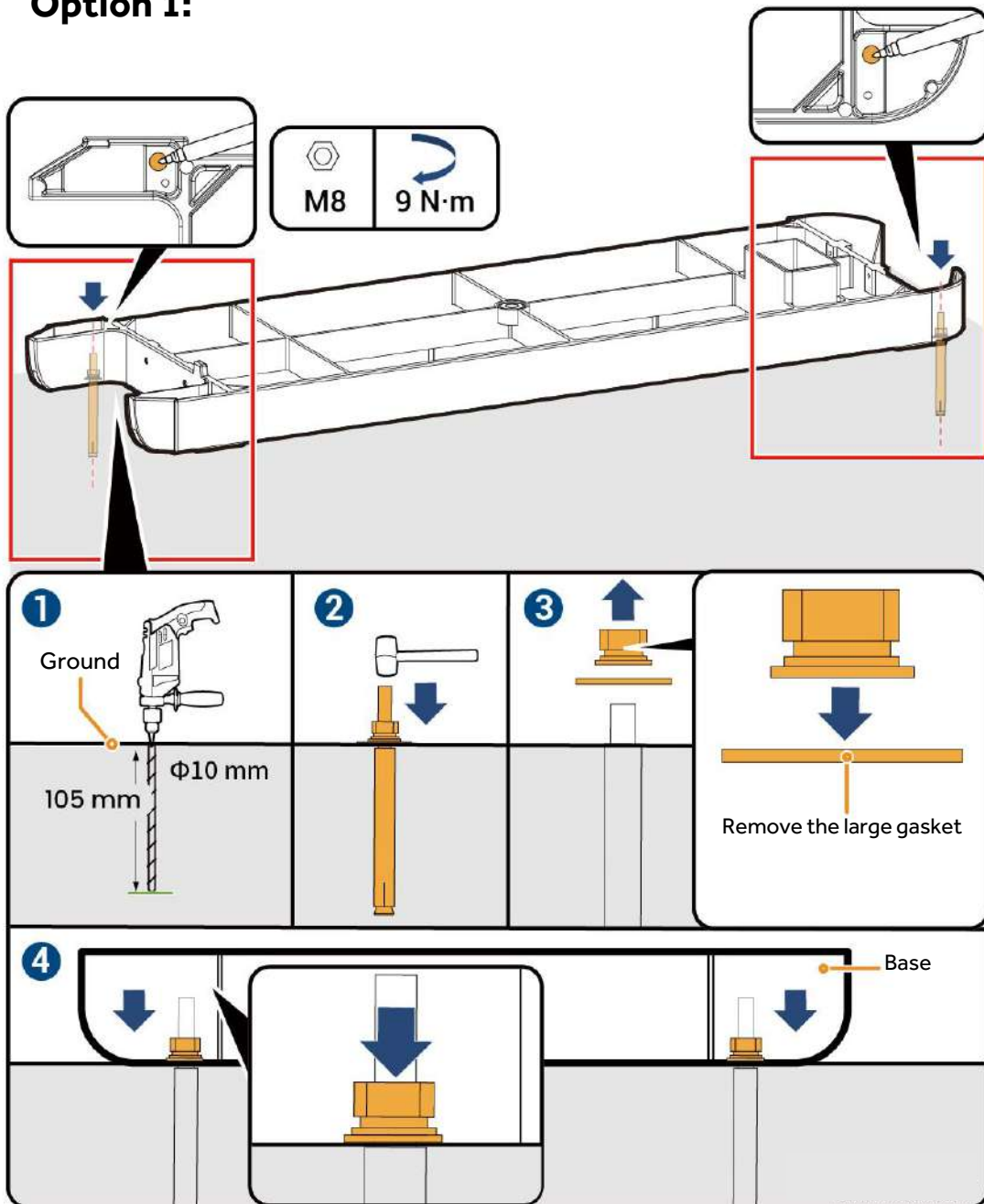

Option 2:

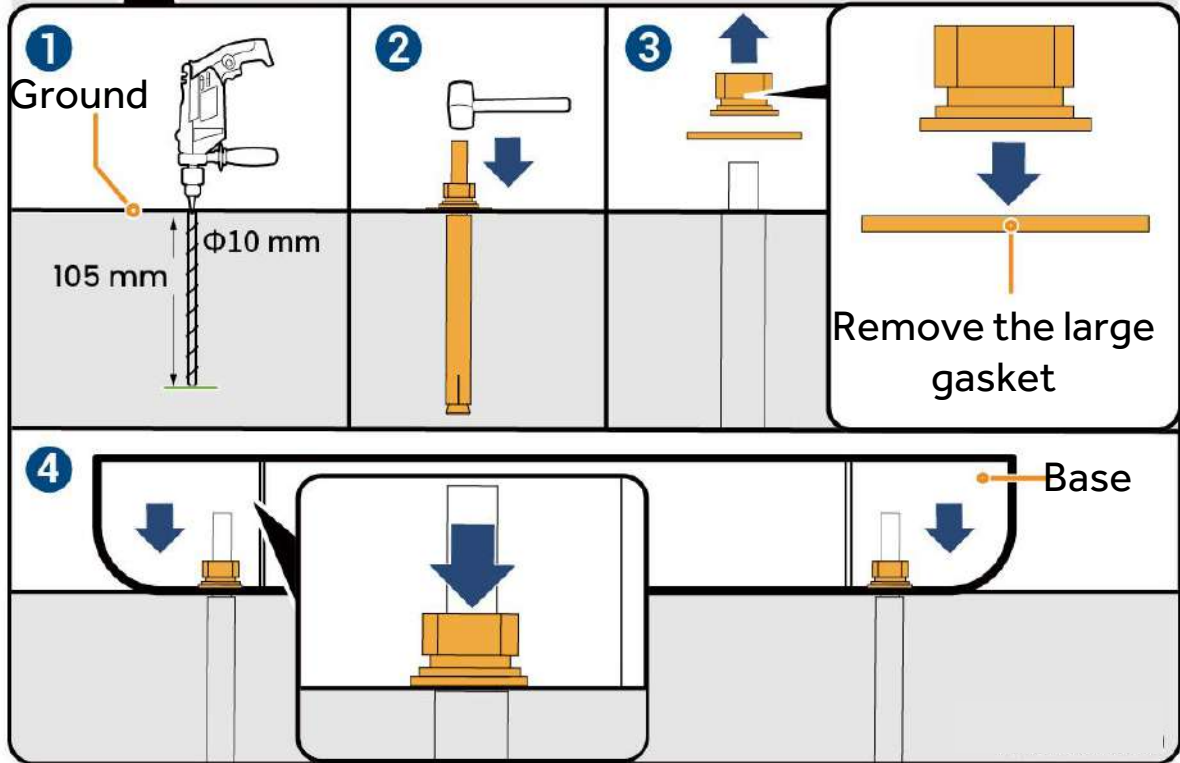
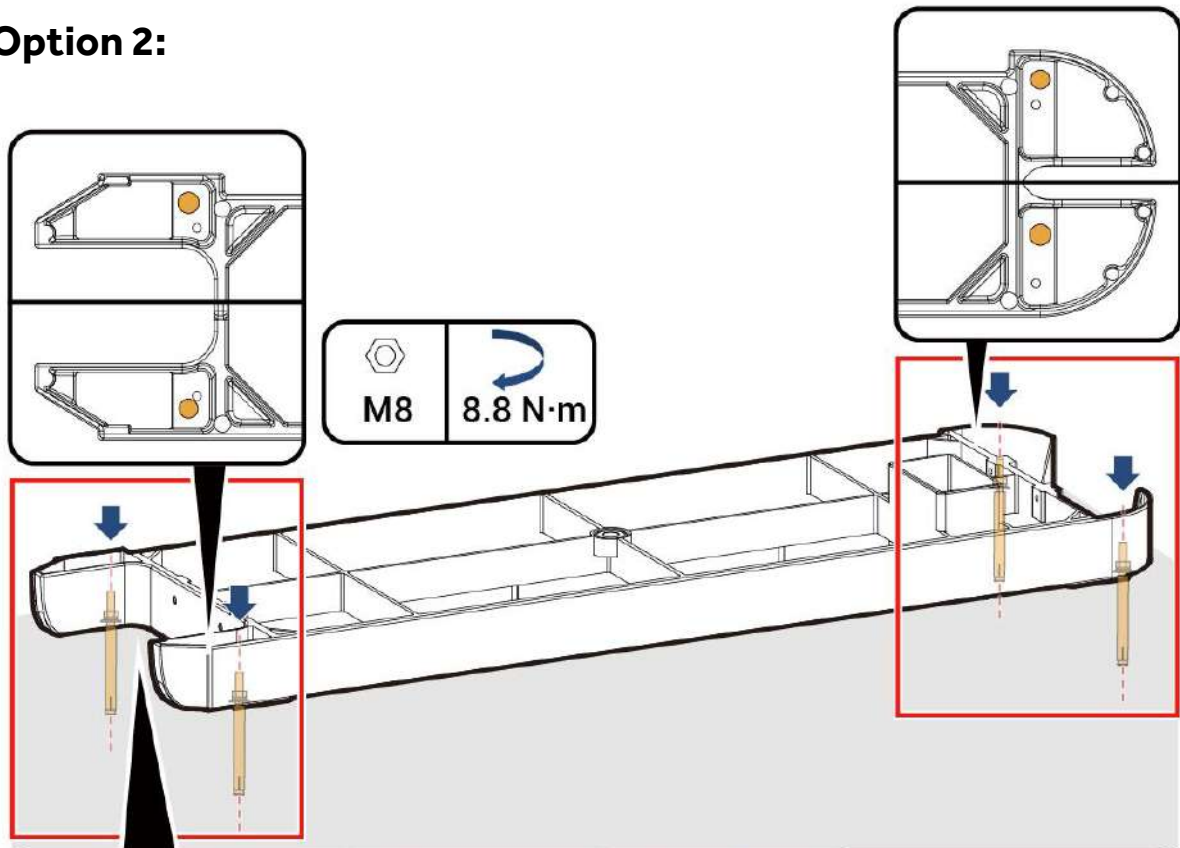

- S** INV1 is the mounting hole on the left side of the inverter for wall installation, while INV2 is the mounting hole on the right side for wall installation.

Calculation formula for punch height:

L1 and L2 should be measured from the upper surface of the base:

$$L1 = N \times 270 \text{ mm} + 261 \text{ mm} \pm 3 \text{ mm}$$

$$L2 = N \times 270 \text{ mm} + 254 \text{ mm} \pm 3 \text{ mm}$$

Note: N is the number of Batteries and N ranges from 3 to 6.

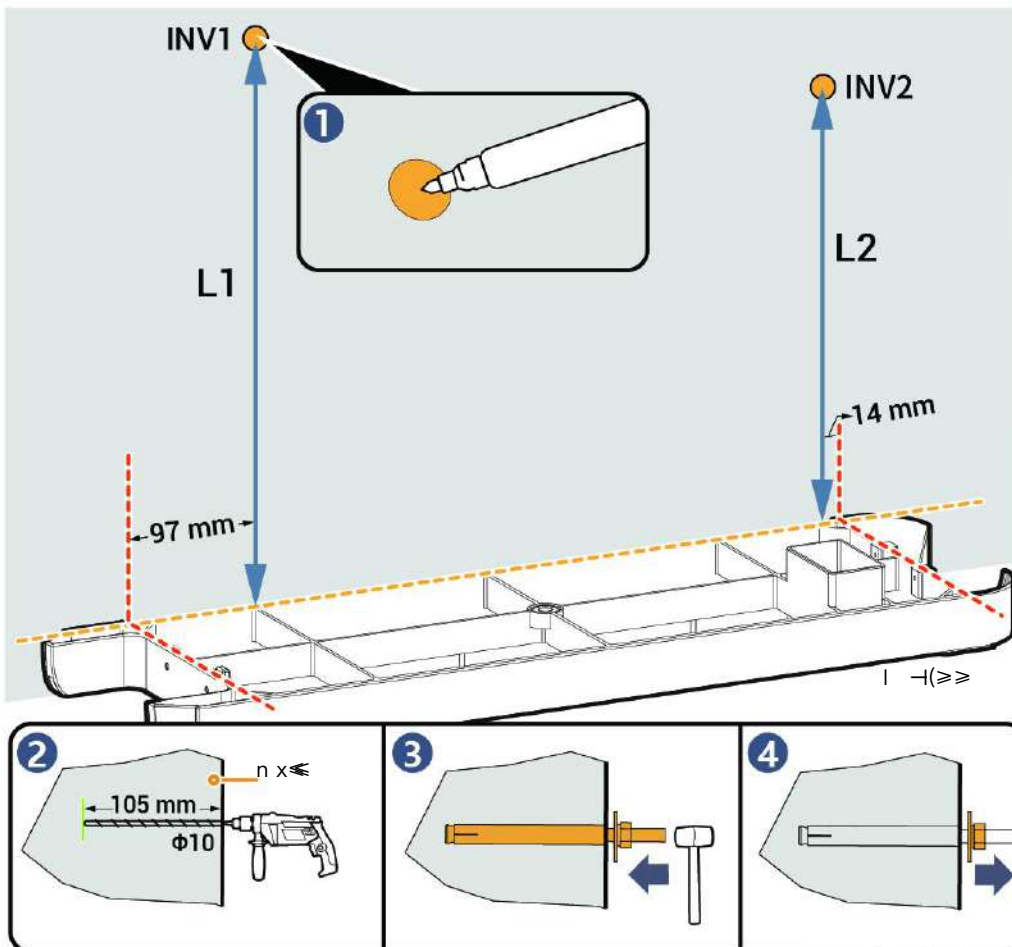

- T** Before installing the handle, please use a Torque socket wrench to measure the screws and confirm that the screws on Battery are securely tightened with a torque of 4.5 N·m (0.45 N·m).

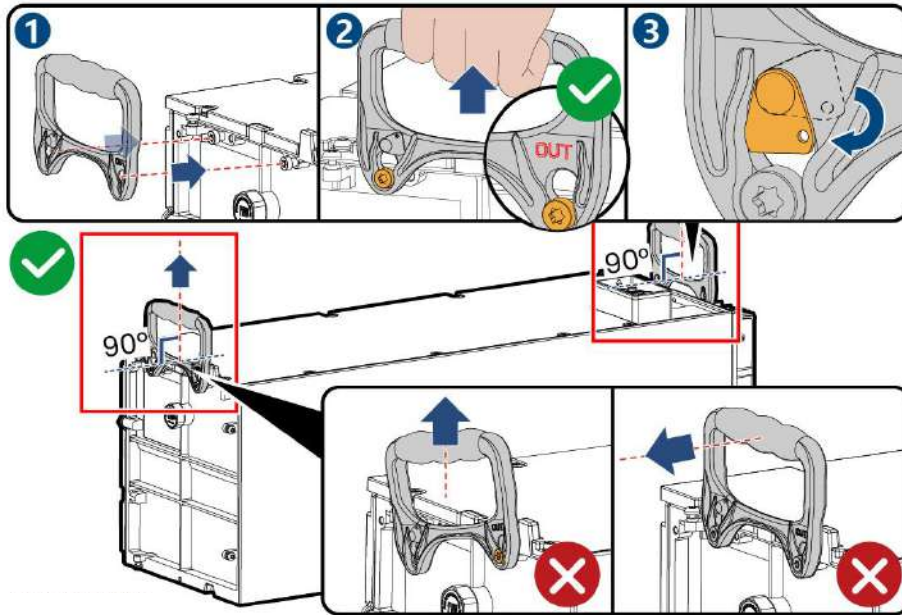

- U** Battery is kept horizontally and mounted vertically downwards.

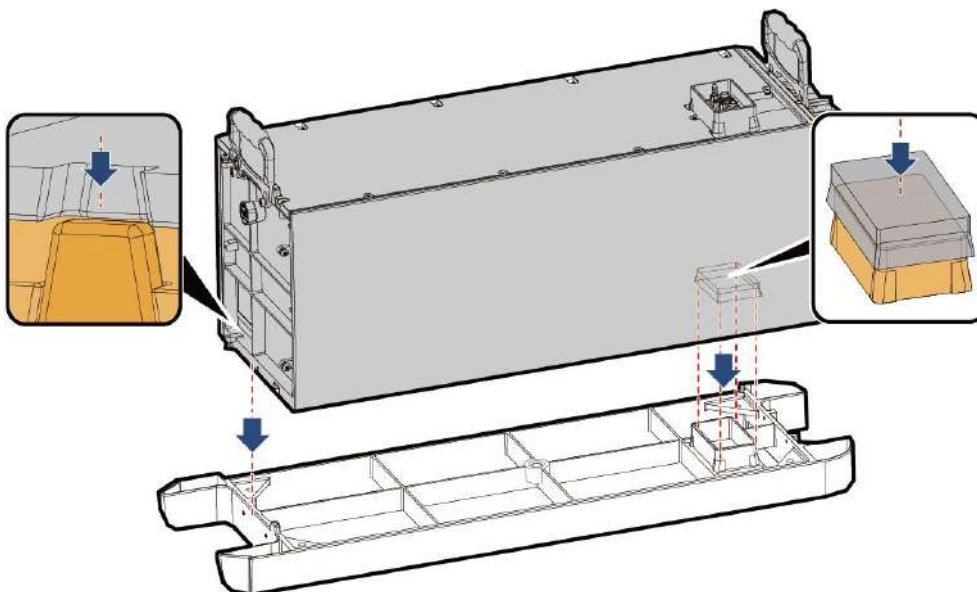

W For details about how to place the second batteries, see Steps **T** **U**

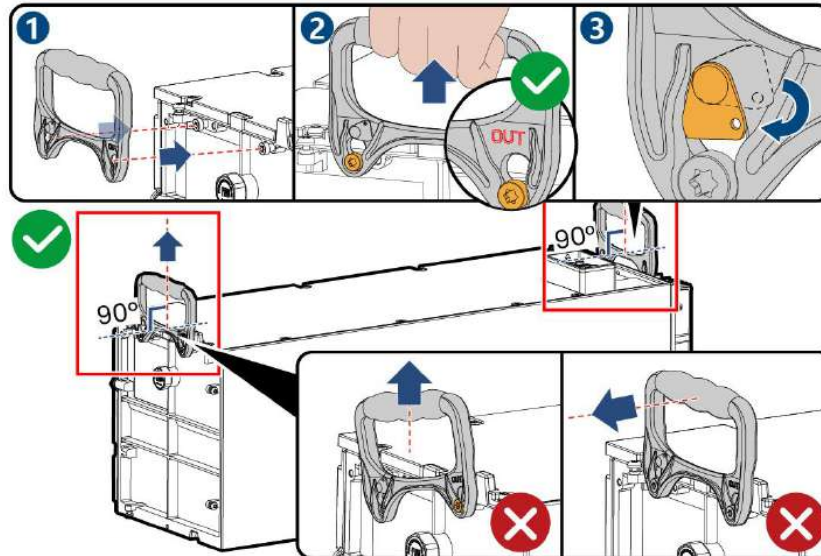

a If three or more Batteries are to be installed, use a Lift. For details about the hoisting rope binding scheme, see the figure.

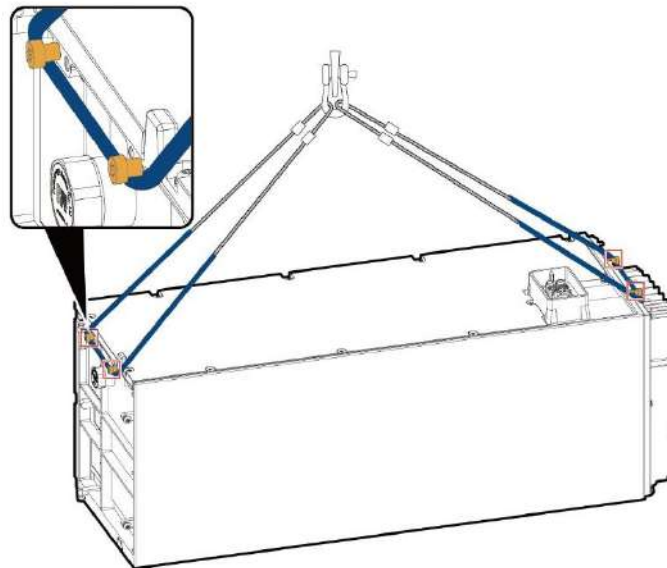

Tips

During lifting operations, the area where the sling comes in contact with the equipment should be wrapped with a protective layer to avoid damage to the equipment.

b Arrange Energy Controller.

Energy Controller

q . A . **T**...C

Tips

. c

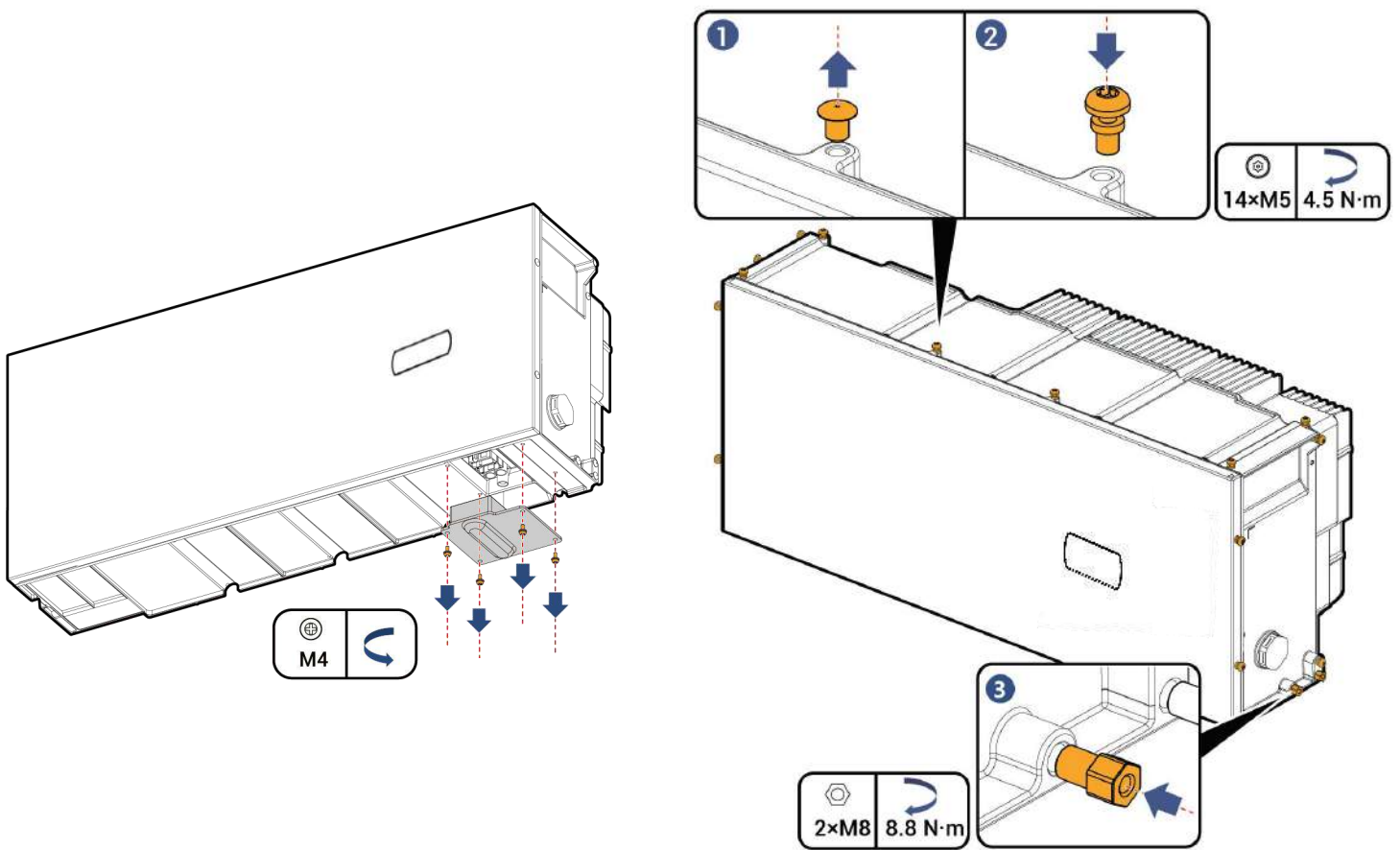

c m c c
. c

I .Ld

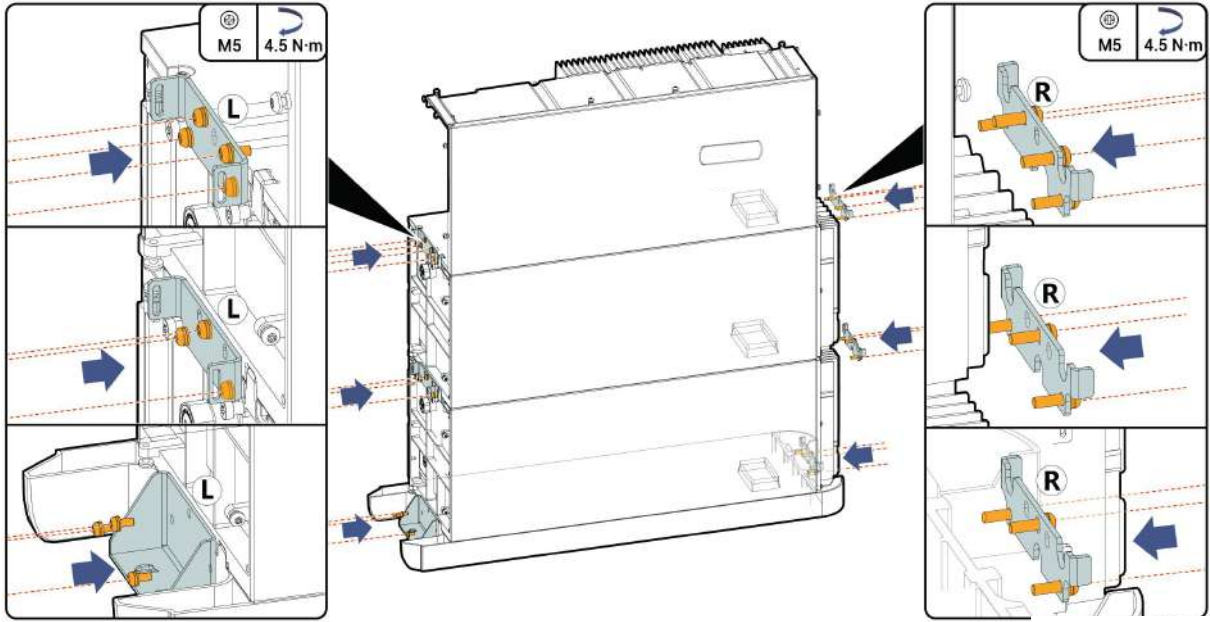

I .Nd

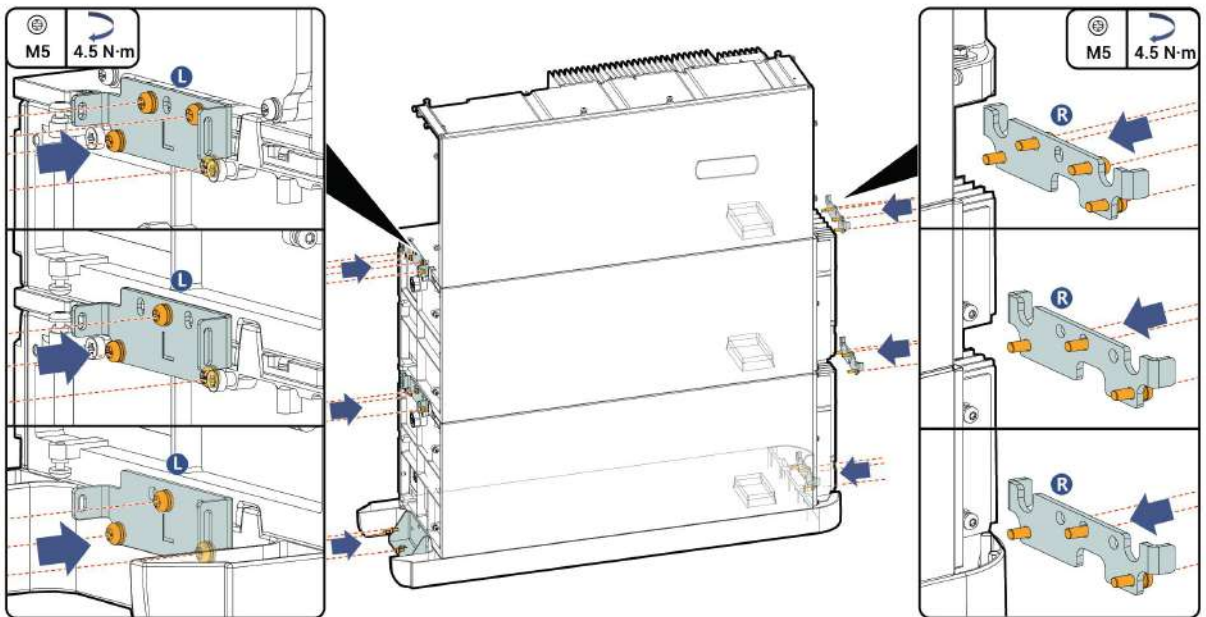



.. 3 .. 4 c

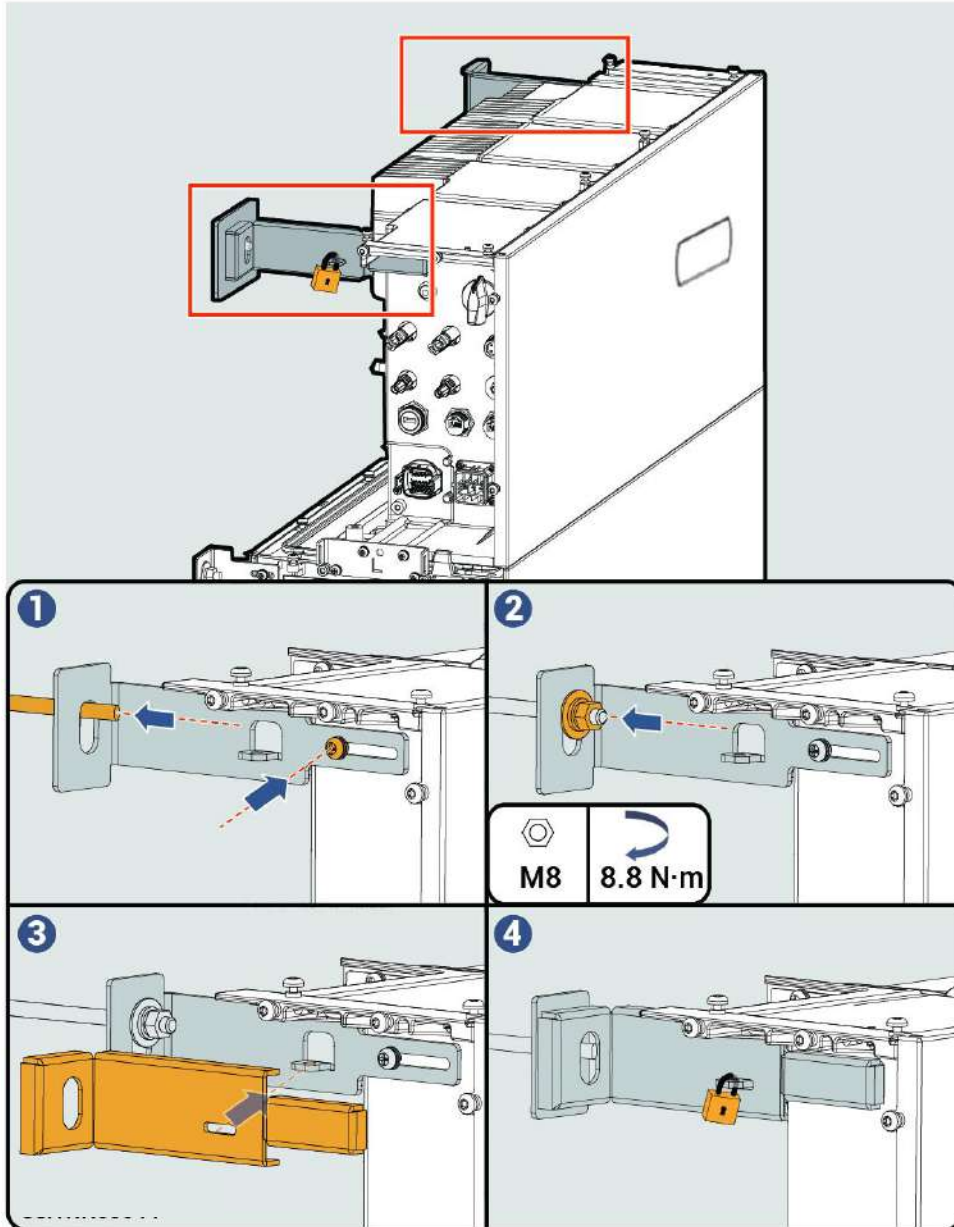

9.2 Wall Installation

L There are two installation methods for the tripod. Please refer to the actual product received for detailed instructions.

Option 1:

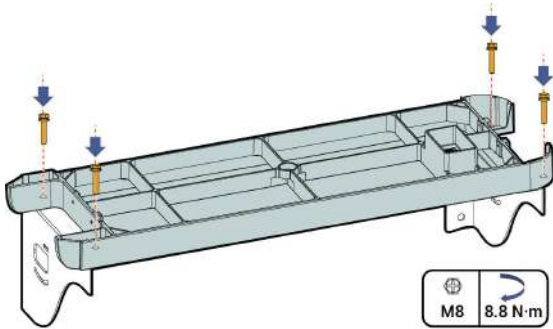

Option 2:

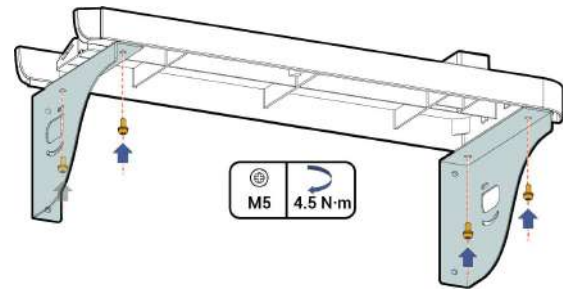

N

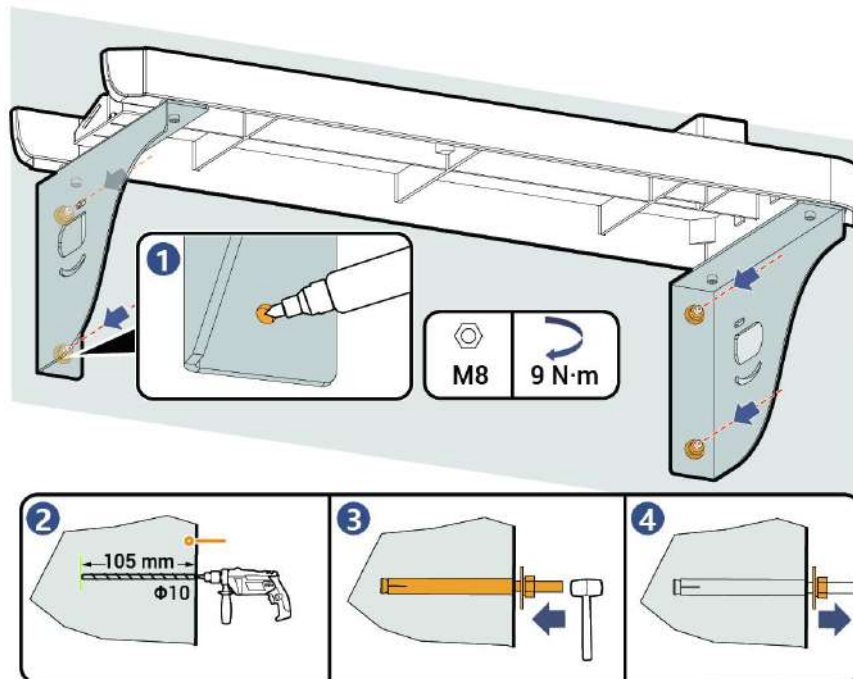

S Calculation formula for punch height:

L1 and L2 should be measured from the upper surface of the base:

$$L1 = N \times 270 \text{ mm} + 261 \text{ mm} \pm 3 \text{ mm}$$

$$L2 = N \times 270 \text{ mm} + 254 \text{ mm} \pm 3 \text{ mm}$$

Note: N is the number of batteries and N is 1 or 2.

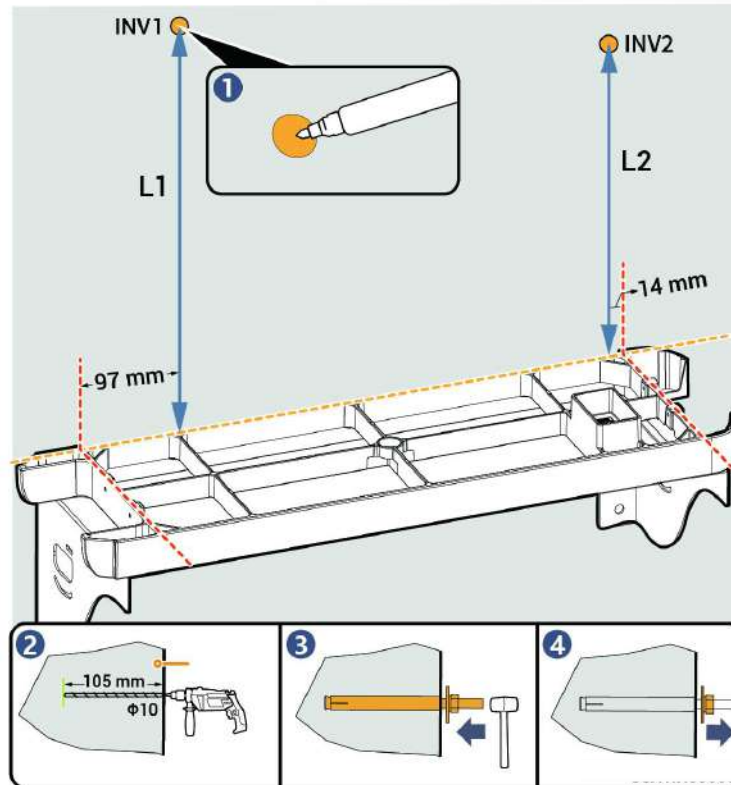

4 For details about how to place the Battery, see Steps 4 5 in Section 8.1 Floor installation.

5 For details about how to place the inverter, see Steps b in Section 8.1 Floor installation.

6 For the installation of the Base bracket, please refer to Step c in Section 8.1 Floor Installation.

7 For the installation of the fasteners for a wall-mounted inverter, please refer to Step LH in Section 8.1 Floor installation.

Chapter 10. Cable Connection and Component Installation

Warning

Before connecting cables, ensure that DC SWITCH is in the OFF state, and the front switch of the AC line is off.

Tips

- The cable colors in the figure are used only to distinguish different lines. The cable colors are based on actual conditions.
- Bind the power cable separately from the signal cable.
- Bind the power cable separately from the signal cable.
- There are three routing schemes, Select them based on the actual situation.
- PVC wiring ducts or PVC conduits are recommended to wrap cables outside decorative parts. 50 30 mm PVC wiring ducts are recommended and PVC conduits with diameter not less than $\Phi 63$ are recommended.

10.1 Recommended Cabling installation

Scheme I

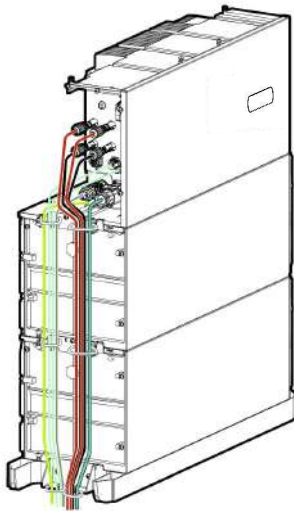

- AC output cable
- RS485 signal cable
- Protective ground cable
- RJ45 cable
- DC input cable

Scheme II

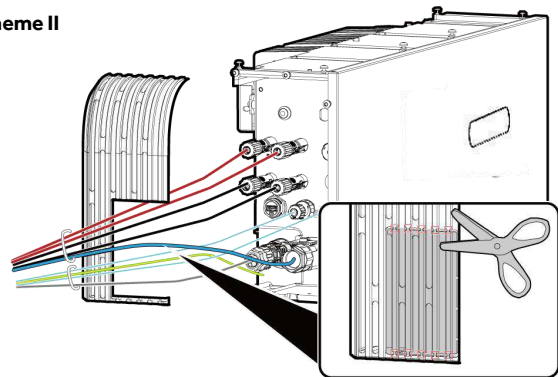

Scheme III

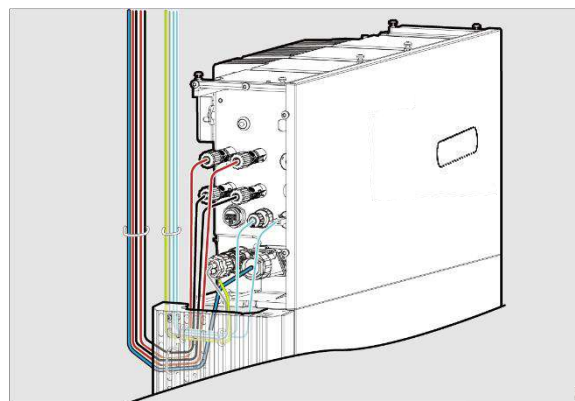

10.2 Protective Ground Cable of Inverter

Tips

-
-
-
-
-
-
-
-
-
-
-
-
-
-
-
-

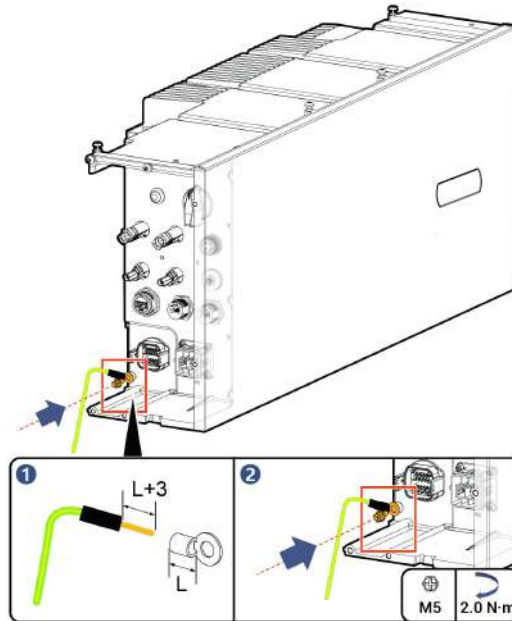

10.3 AC Output Cable of Inverter

Unit: mm

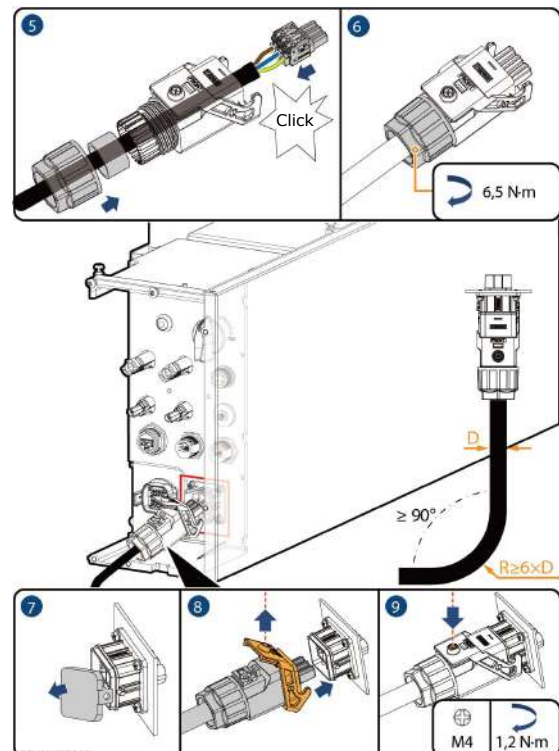
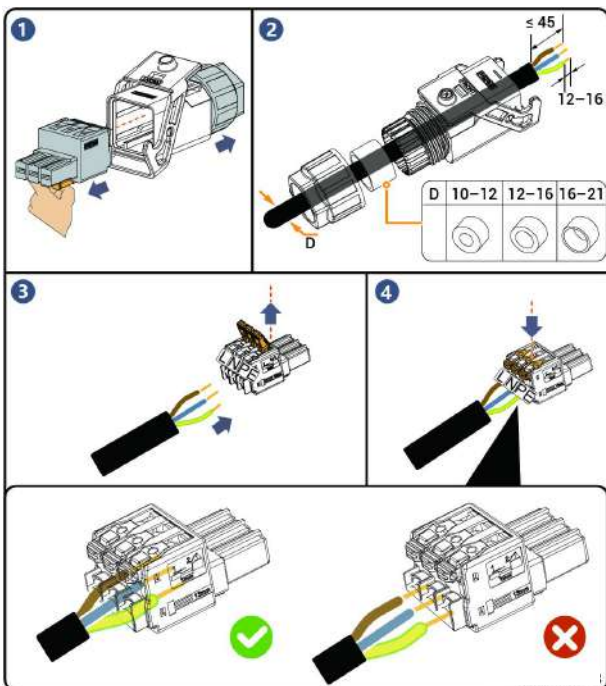

10.4 RS485 Signal Cable

COM terminal of the inverter

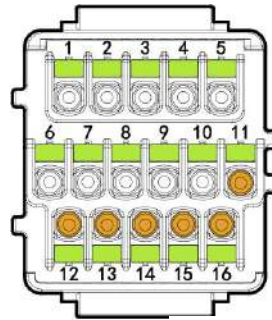

Tips

- Power sensors need to be purchased from our official channel.
- The appearance and specific wiring of the power sensor can be found in the instruction manual delivered with the case.

Description	Interface definition	COM terminal of the inverter	HMS-A (SDM230Modbus)	HMS-CT120A (SDM120CT 40mA)
(Reserved) DO1, connected to third party intelligent electric equipment, such as switch control and heat pump	Dry contact 1 – Common	1	–	–
	Dry contact 1 – NO	2	–	–
(Reserved) DO2, connected to third party intelligent electric equipment, such as switch control and heat pump	Dry contact 2 – Common	3	–	–
	Dry contact 2 – NO	4	–	–
(Reserved) For power scheduling, such as DRM and Ripple control	DI1, digital input 1	5	–	–
	DI2, digital input 2	6	–	–
	DI3, digital input 3	7	–	–
	DI4, digital input 4	8	–	–
	DI5, digital input 5	9	–	–
	Signal GND	10	–	–
RS485–2, COM port used to access the power sensor	PE signal shielding ground	12	–	–
	RS485 signal 2_B–	13	6	9
	RS485 signal 2_A+	14	5	10
RS485–1, custom RS485 port	PE signal shielding ground	11	–	–
	RS485 signal 1_A+	15	–	–
	RS485 signal 1_B–	16	–	–

9.4.1 RS485 Signal Cable of inverter

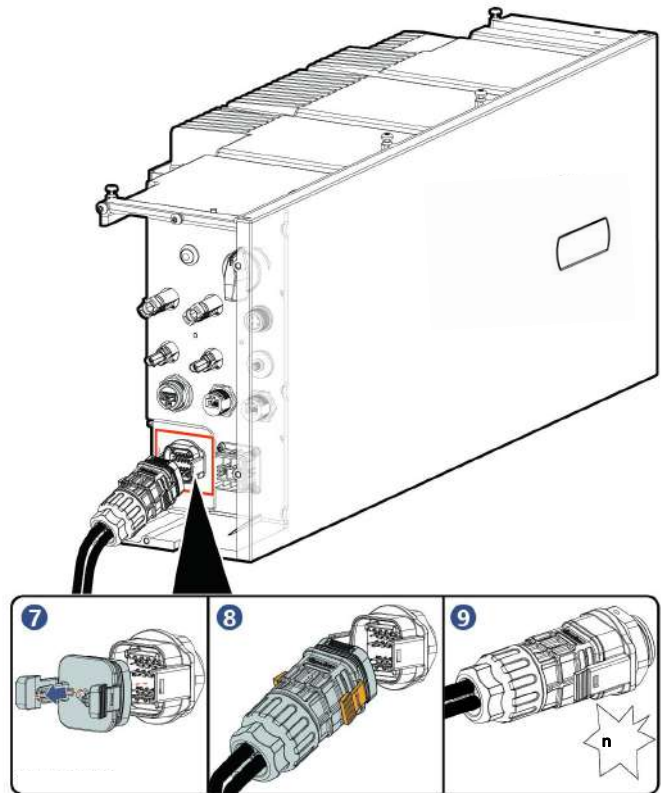
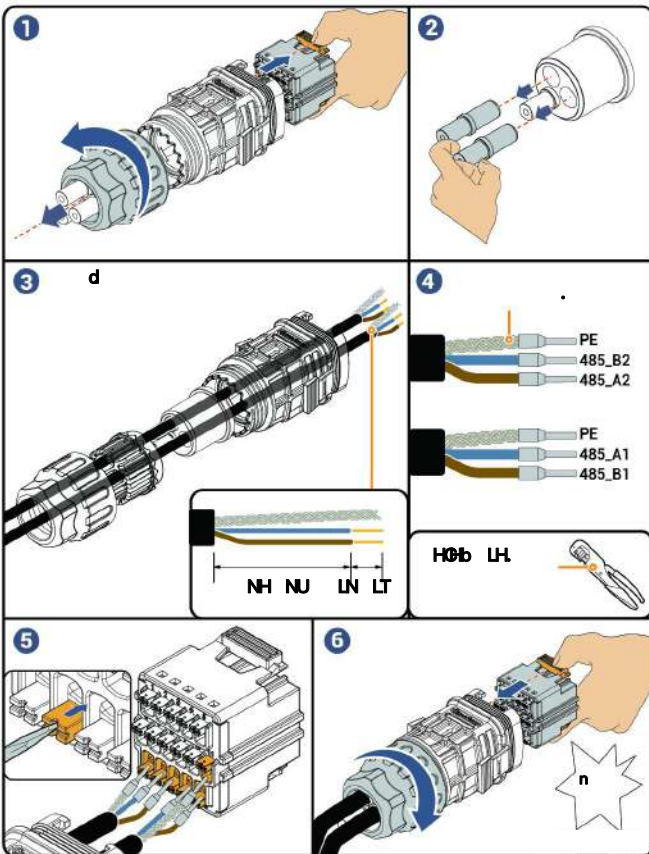

10.5 RJ45 Cable of Inverter

Tips

- RJ45 cables are EIA/TIA 568B standard cables.
- Two RJ45 Ethernet ports, one of which is connected to the router, and the other is connected to other devices (e.g., inverters, gateways, etc.).

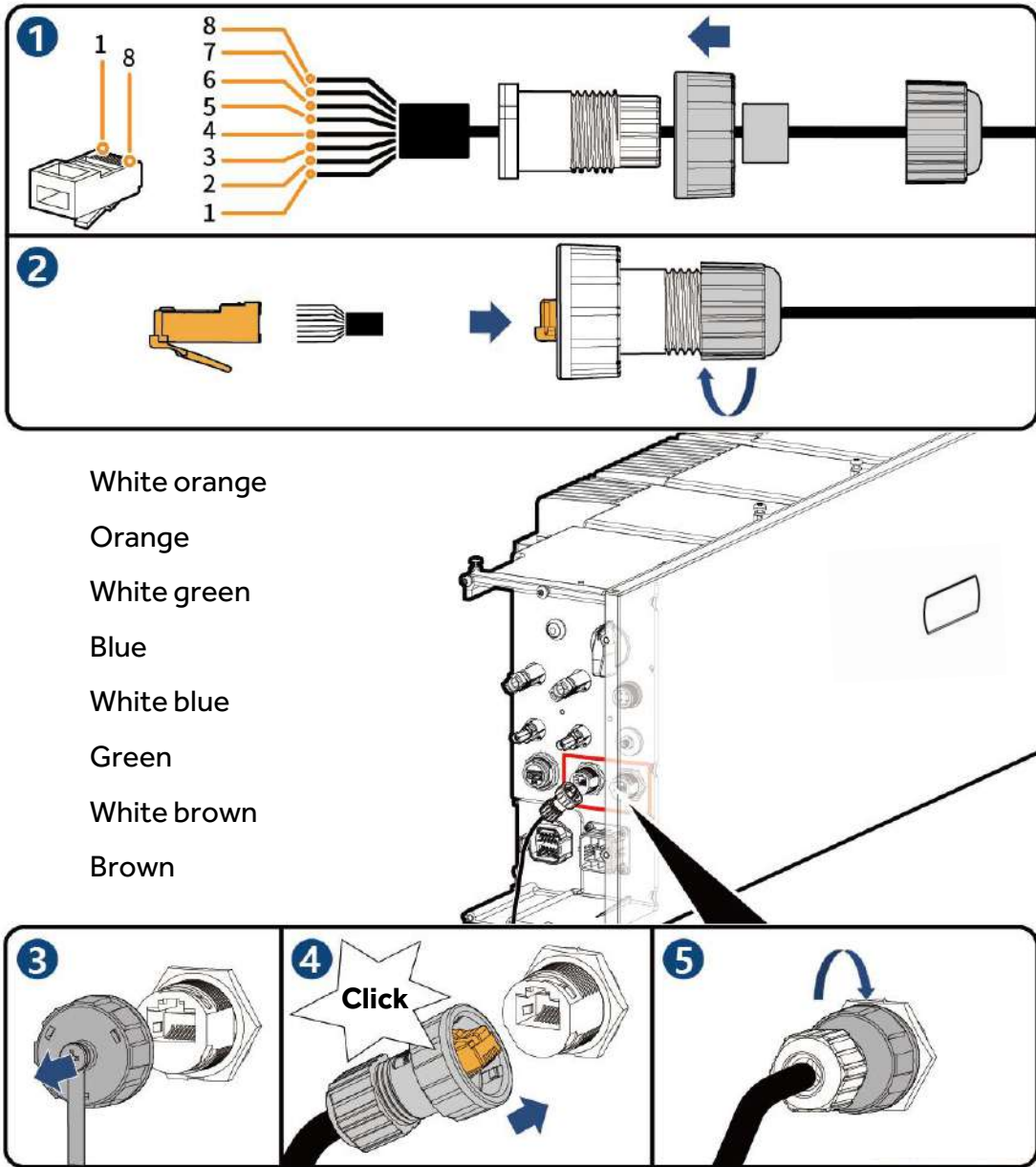

10.6 CommMod Installation

Tips

CommMod is required for 4G communication.

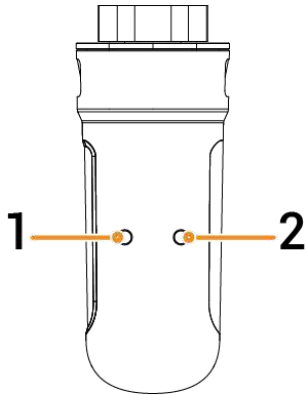

S/N	Indicator	Description
1	Power indicator	–
2	Network state indicator	<ul style="list-style-type: none"> • Slow flashing (200ms on/1800ms off): The network is being connected • Slow flashing (1800ms on/200ms off): Standby • Quick flashing (125ms on/125ms off): Data is being transferred

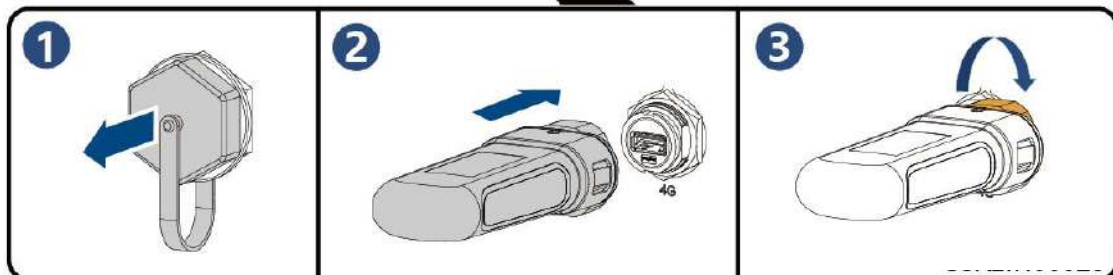
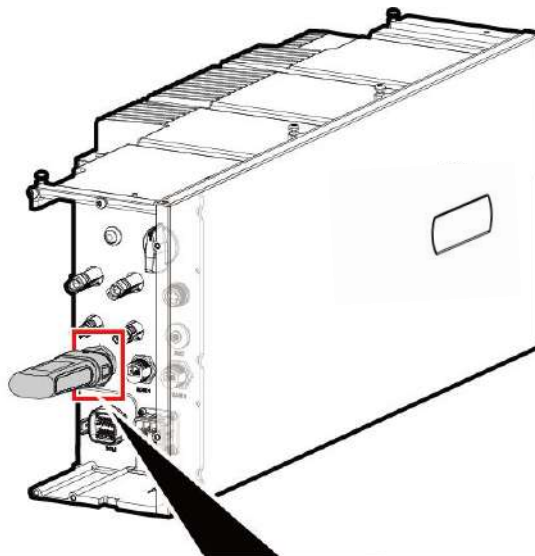

10.7 WLAN antenna stick Installation

Tips

w y. w y. . C

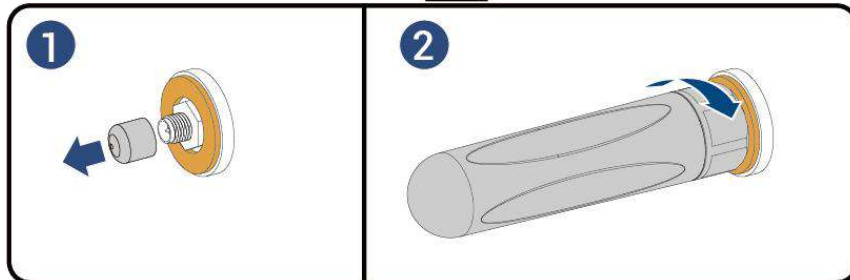
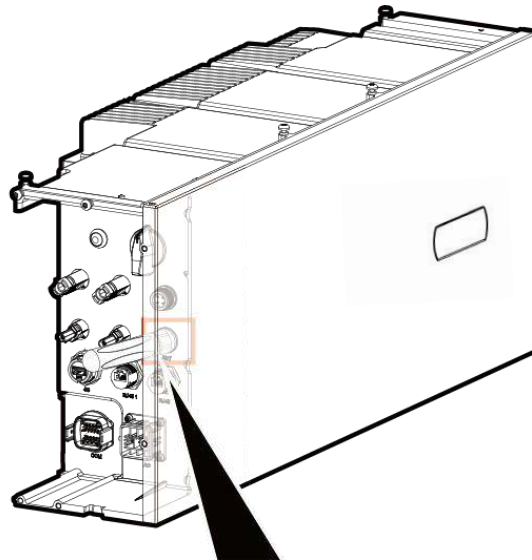

10.8 DC input cable of Inverter

Tips

The DC cable is connected to the inverter from the PV string.

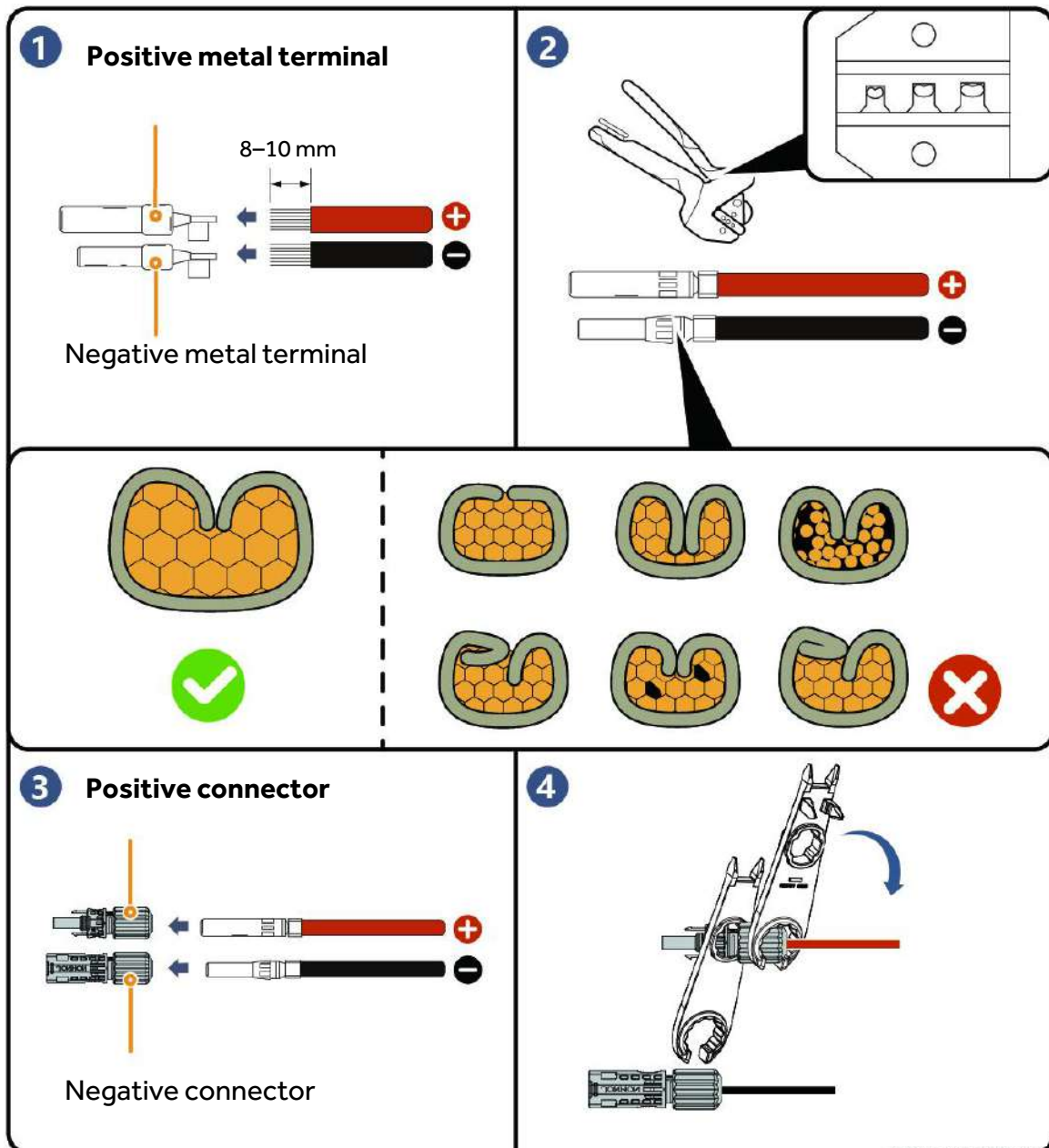

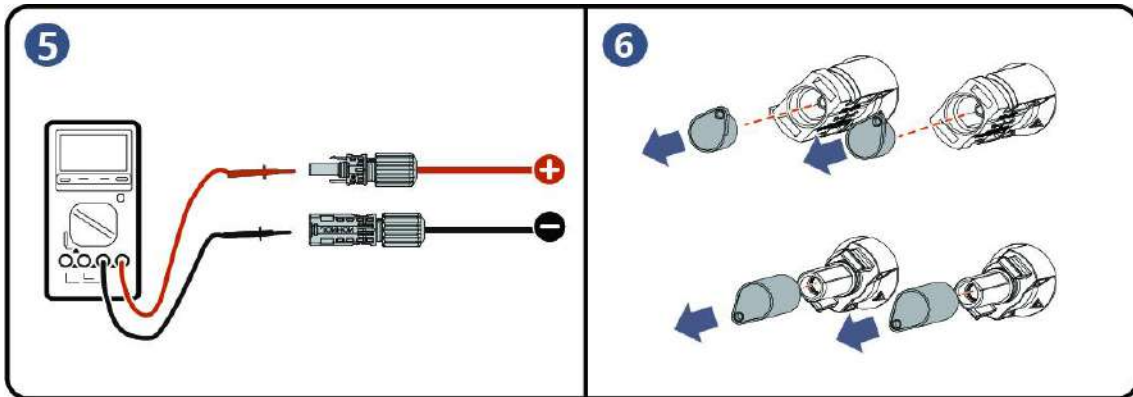

⚠ Caution

- If the voltage is negative, the polarity is incorrect. Rectify the fault in time.
- If you have only one DC input, connect it to PV1.

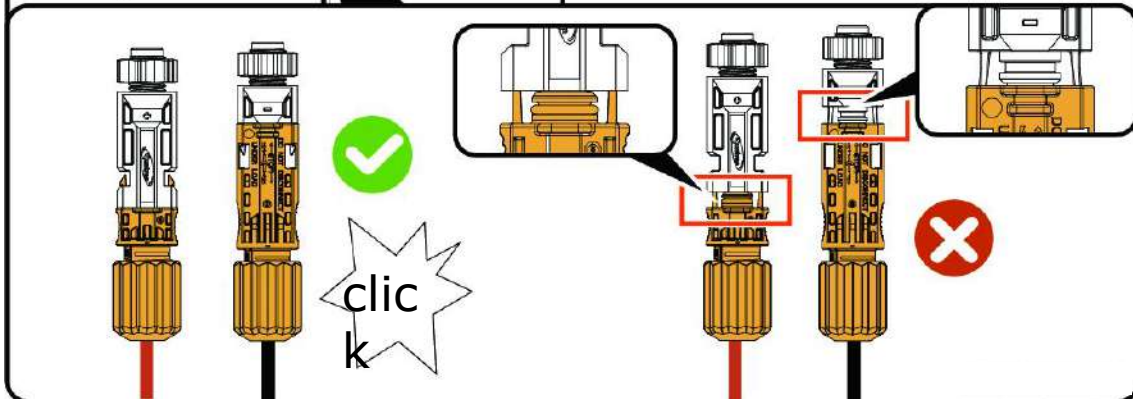
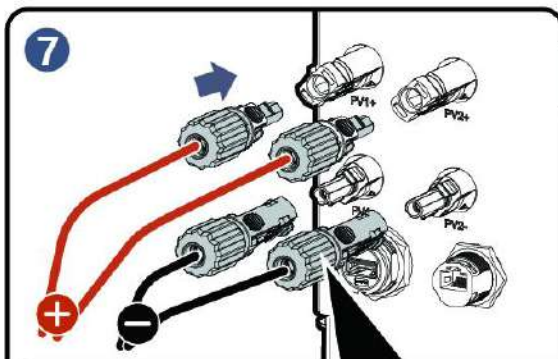
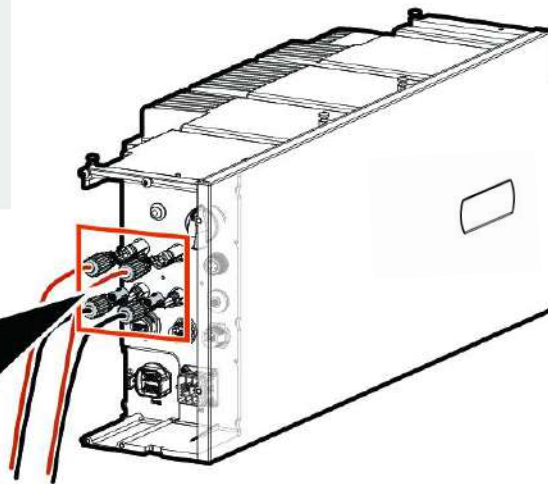

Chapter 11. Post-installation Check

Code	Check Item
1	The equipment has been securely installed.
2	Ground cables, DC cables, signal cables, etc. are installed accurately without leftovers.
3	The cable fastening screws or terminals are properly installed.
4	There are no sharp spikes or acute angles at the cut point of the cable tie.
5	DC SWICH is in the OFF state.
6	Ports that are not in use have waterproof covers or plugs installed.
7	There is no construction left inside or outside the equipment.

P± (z ±⇒x - ④- x↖x (Rx (x } (U ² (S ≤ (} z x - (z 8

Chapter 12. Installation of the Decorative Cover

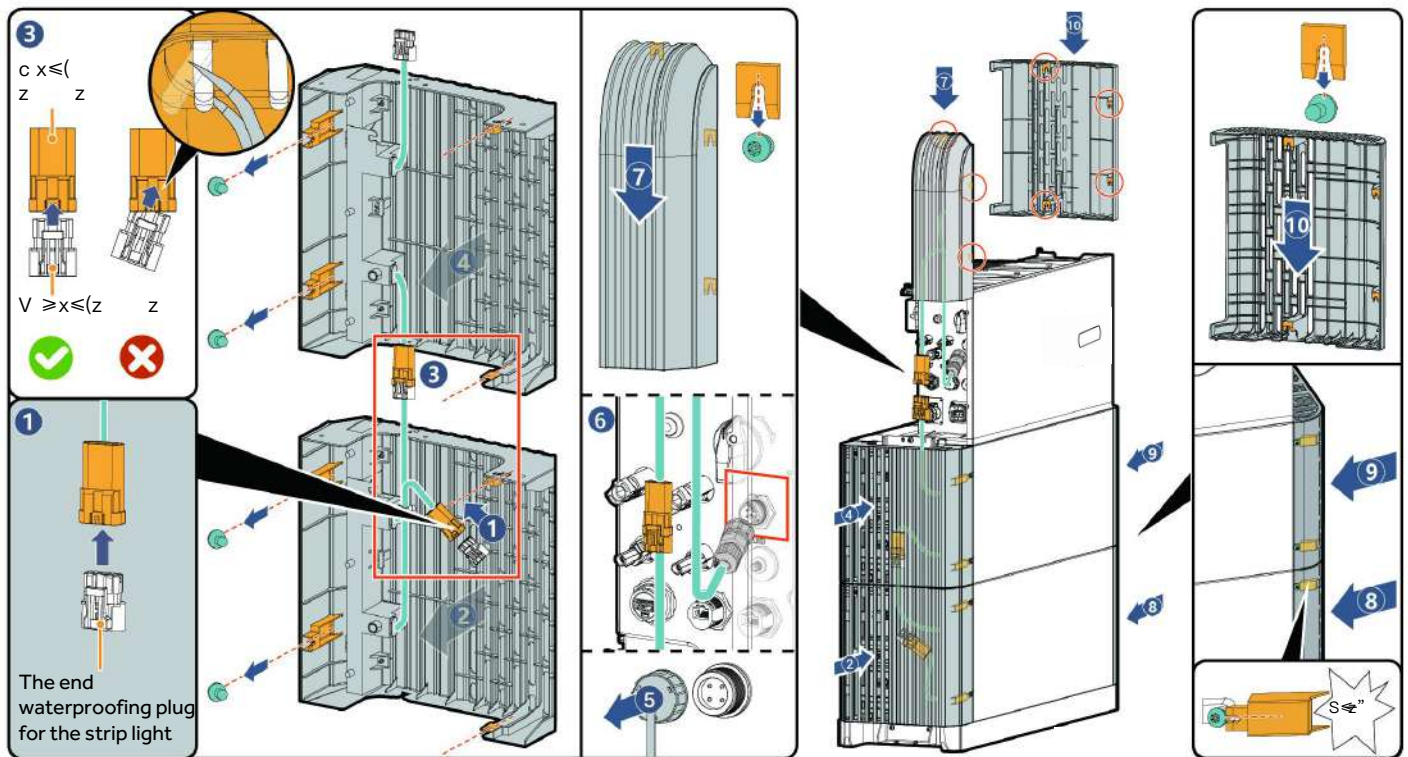

⚠ Caution

- The end waterproofing plug for the strip light in step **L** is at the lower end of the decoration on the left side of the inverter, please remove it for spare.
- If the equipment is not equipped with a decorative cover light strip, ignore Steps **L S U W** in the figure.
- If the strip light shows abnormal status when the device is powered on, check if the pins in the male connector are tilted. If tilted, straighten them out, reconnect the corresponding male and female connectors, or reconnect the terminal in Step **W** to resume normal operation.

Chapter 13. Equipment Power-On

1. Turn on the front switch of the equipment.
2. Rotate DC SWITCH to ON.
3. Observe the indicators on the front side of the inverter to learn about the equipment status.

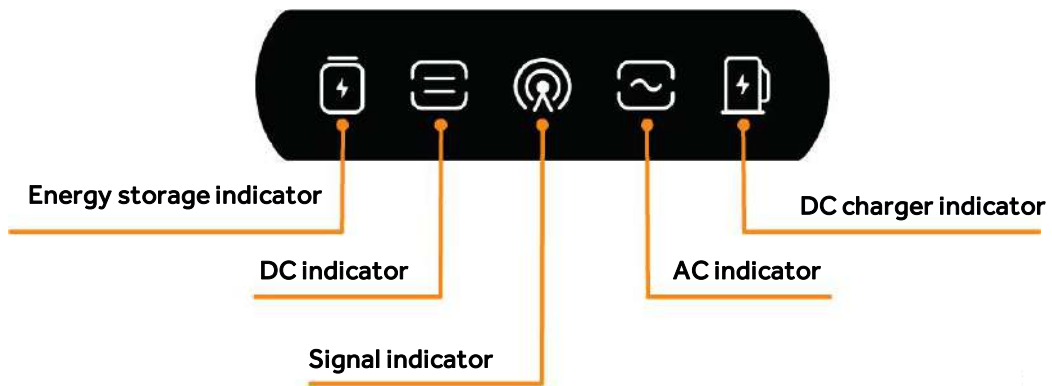

Indicator	Color	State	Description
		Always on	All batteries are connected but not running.
		Flash	Battery is charging.
		Flash	Battery is discharging.
		-	All batteries lie dormant.
		Flash	Some batteries are faulty.
		Always on	All batteries are faulty.
		Always on	The DC side is connected but not running.
		Always on	The DC side is running.
		-	The DC side is not connected.
		Flash	The DC side is faulty.
		Always on	The inverter is faulty.
		-	The management system is not connected.
		Flash	Connected to local App.
		Always on	Connected to the management system using an FE or WLAN.
		Always on	Connected to the management system over 4G.
		Flash	Insufficient traffic for CommMod.
		Always on	The AC side is connected but not running.
		Always on	Grid-connected operation.
		Always on	Off-grid operation.
		-	The AC side is not connected.
		Flash	Off-grid overload operation.
		Flash	The AC side is faulty.
		Always on	The inverter is faulty.

After powering on the equipment, install the remaining decorative covers.

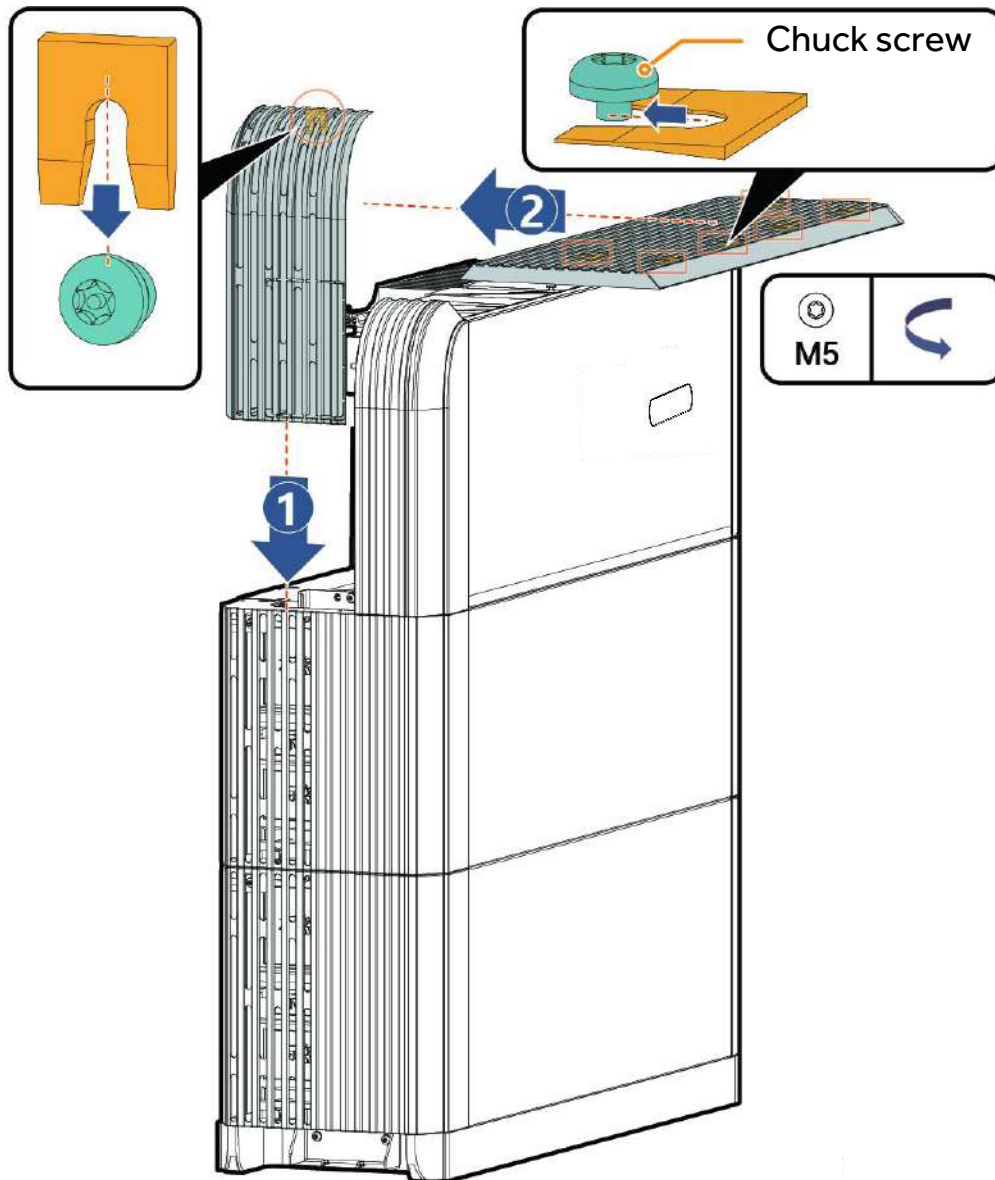

Chapter 14. Downloading “Haier Smart Cube” App and Creating New System

L Download the “Haier Smart Cube” app to initiate the creation of a new system for your equipment.



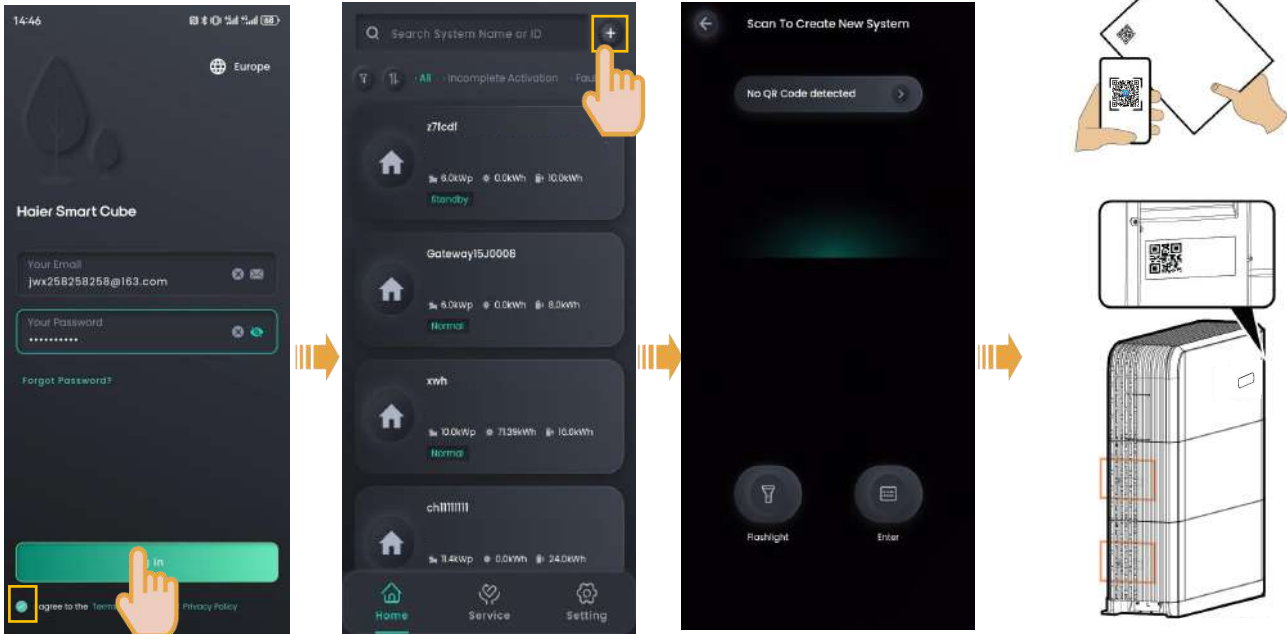

Scan the SN code label on the accompanying box material. If the SN is lost, scan the SN on the side of the inverter or Battery.

Tips

The following steps are different when the equipment has already been connected or not connected to the internet (that is, FE and 4G communication fault), as described below.

Already connected to the internet:

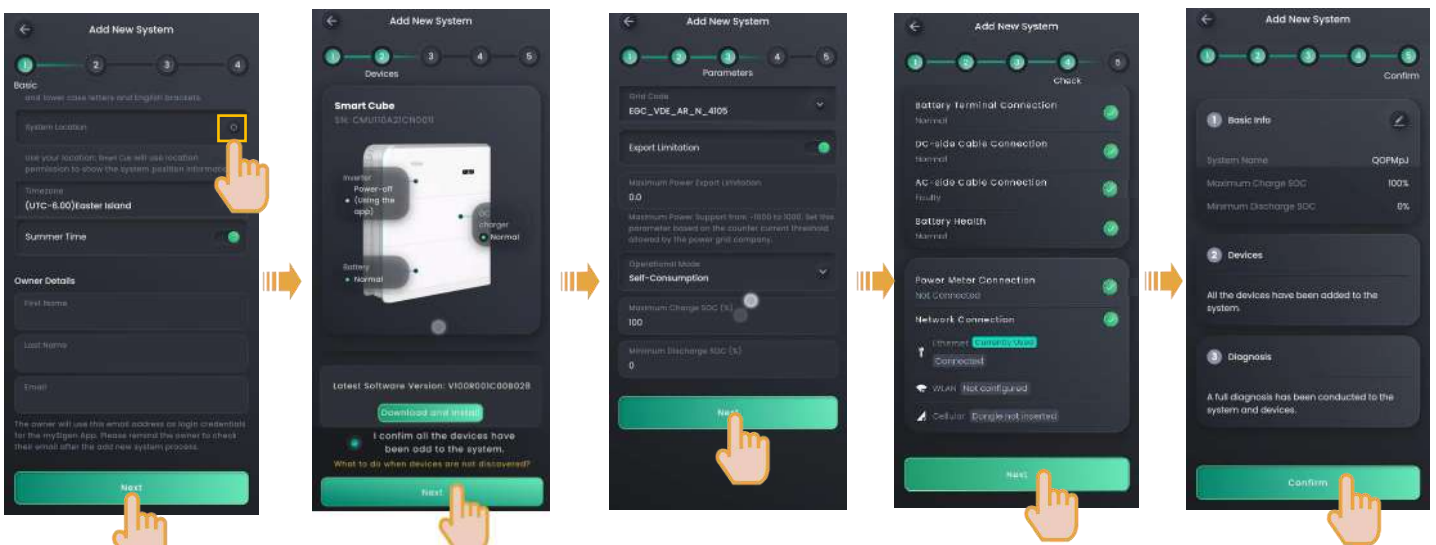

Manually locate the address, set the Timezone, and enter Owner Details.

Perform upgrades where necessary.

You can manually set and modify some function parameters of the power station.

Upon completion of the new system creation, the installer shall inform the owner to check its "NAHUI cloud" e-mail within 24 hours and proceed with activating its account.

Not connected to the internet (that is, FE and 4G communication fault):

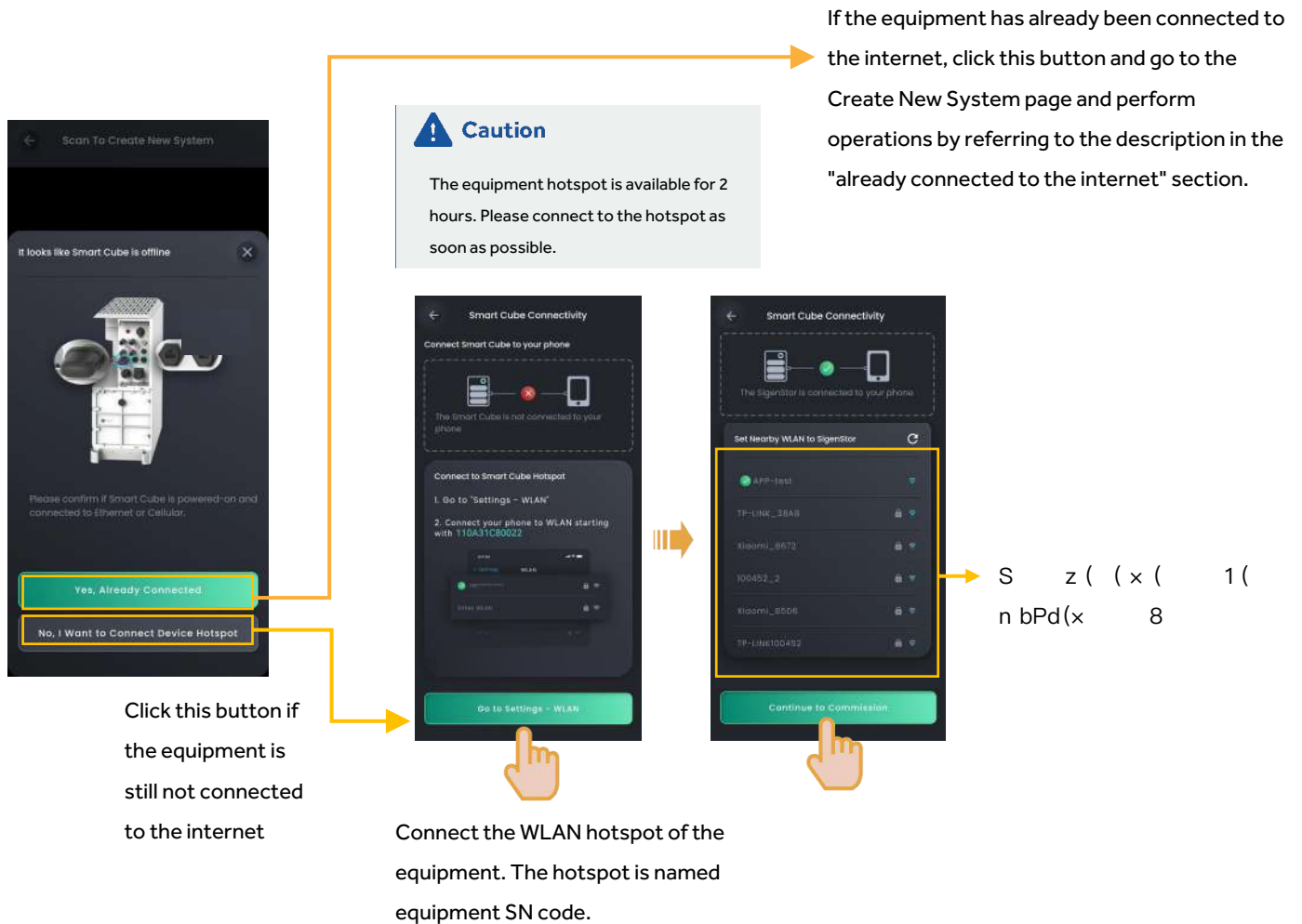

Haier



Official website of NAHUI



Haier Smart Cube

Qingdao Nahui Intelligent Technology Co., Ltd.

📍 Room 205-2, Building 4, No. 7 Keji 1st Road, Aoshanwei Street Office,
Jimo District, Qingdao City, Shandong Province, P.R. China

🌐 www.eur.nahui-newenergy.com

20240418_V1.0