

OVVO® V Connection System

V-1230 Permanent Specifications

V-1230 Permanent

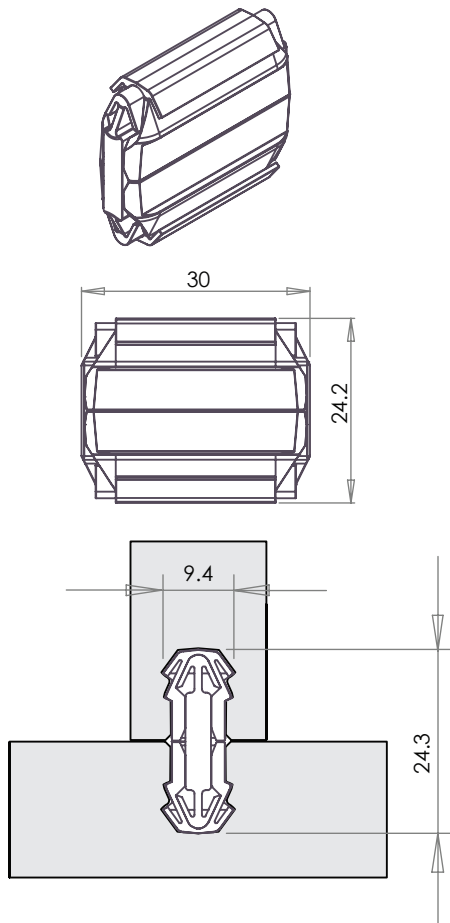

V-1230PH

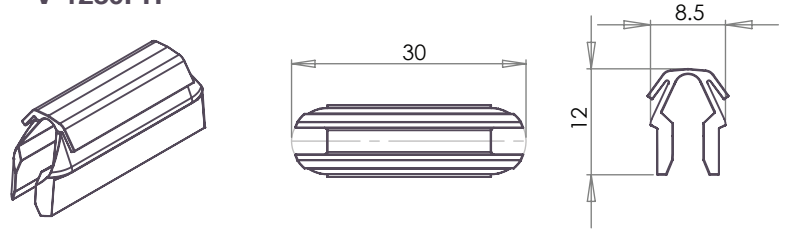

V-1230PC

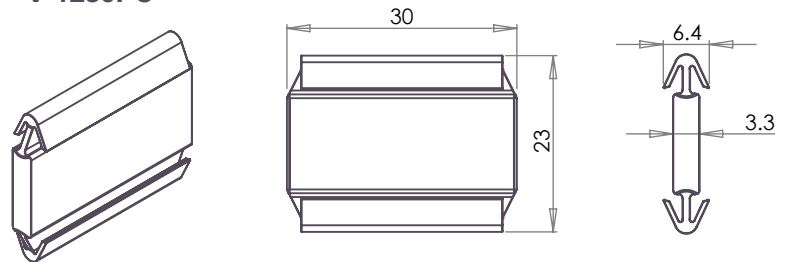

V-1230PH

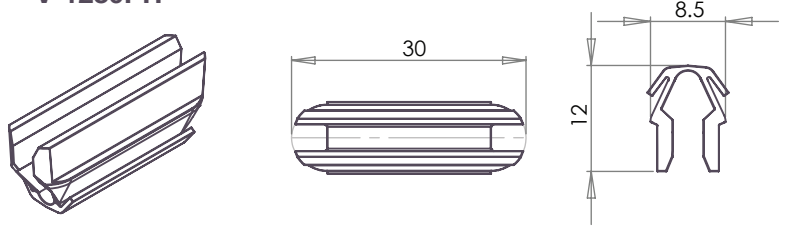

- (i) Plunge
- (ii) Travel
- (iii) Out

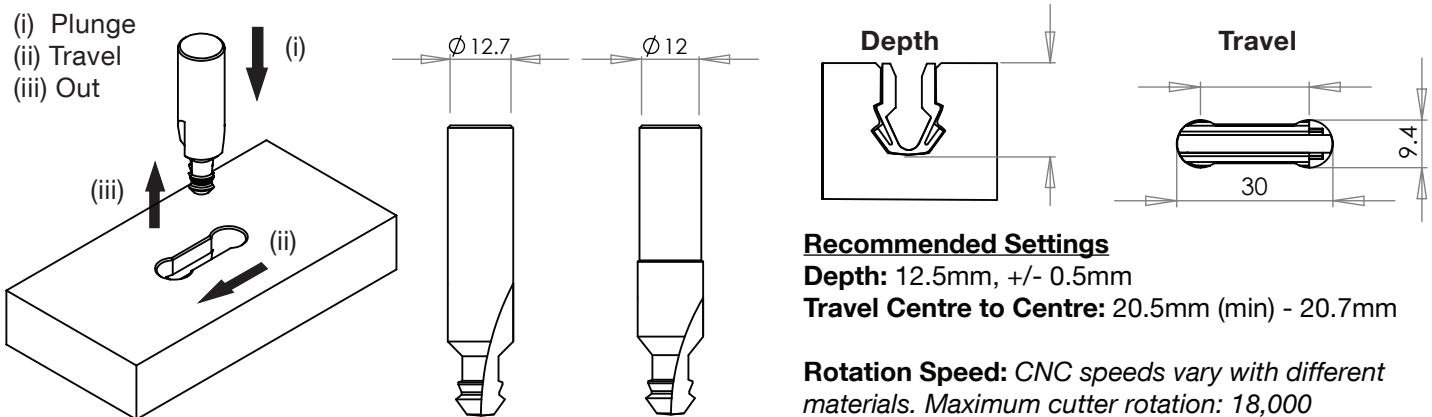

Recommended Settings

Depth: 12.5mm, +/- 0.5mm

Travel Centre to Centre: 20.5mm (min) - 20.7mm

Rotation Speed: CNC speeds vary with different materials. Maximum cutter rotation: 18,000

How it works

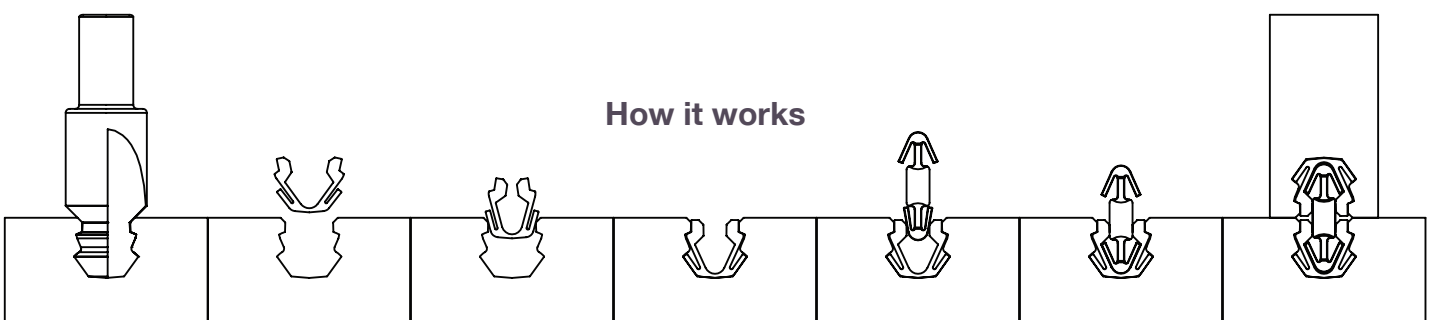

OVVO® V Connection System

V-1230 Releasable Specifications

V-1230 Releasable

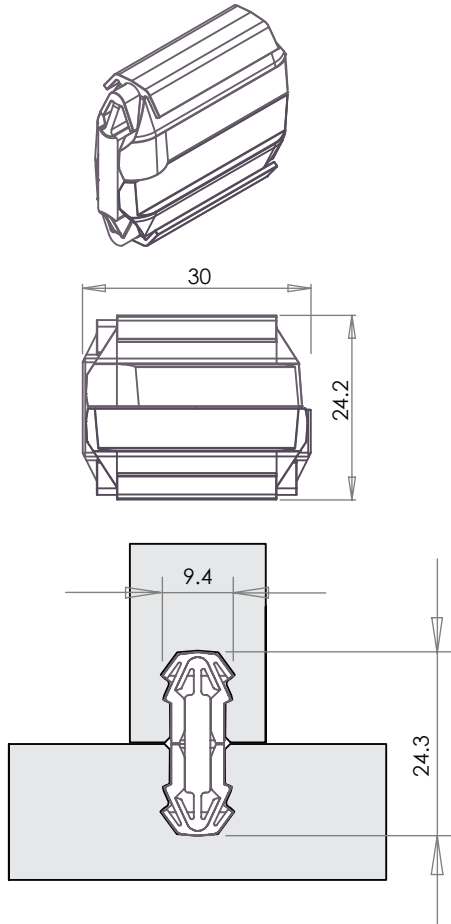

V-1230RH

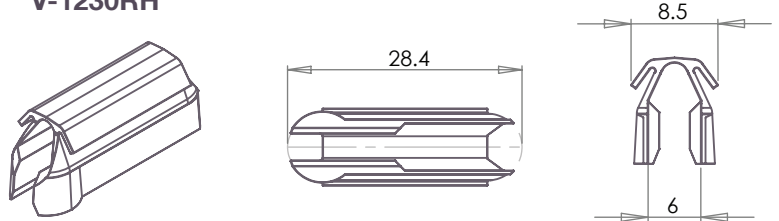

V-1230RC

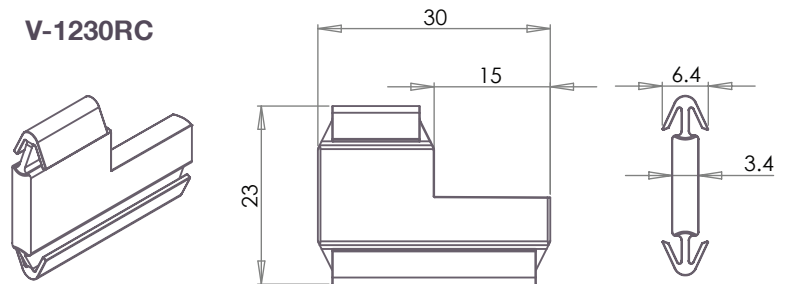

V-1230PH

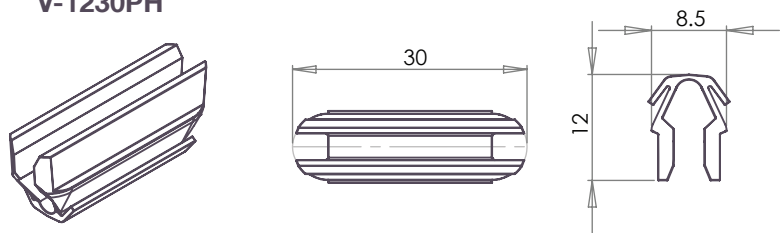

(i) Plunge
(ii) Travel
(iii) Out

Recommended Settings
Depth: 12.5mm, +/- 0.5mm
Travel Centre to Centre: 20.5mm (min) - 20.7mm

Rotation Speed: CNC speeds vary with different materials. Maximum cutter rotation: 18,000

How it works

