

TOWBAR CONNECTION TOOTHED WASHER 75 VU

Height-adjustable with drawbar section up to 750 kg



TECHNOLOGY

Drawbar type 75 VU vers. A 1

Intermediate piece with drawbar section

Permitted nose load 100 kg

ECE type approval no.:

E1 55R-01 0266

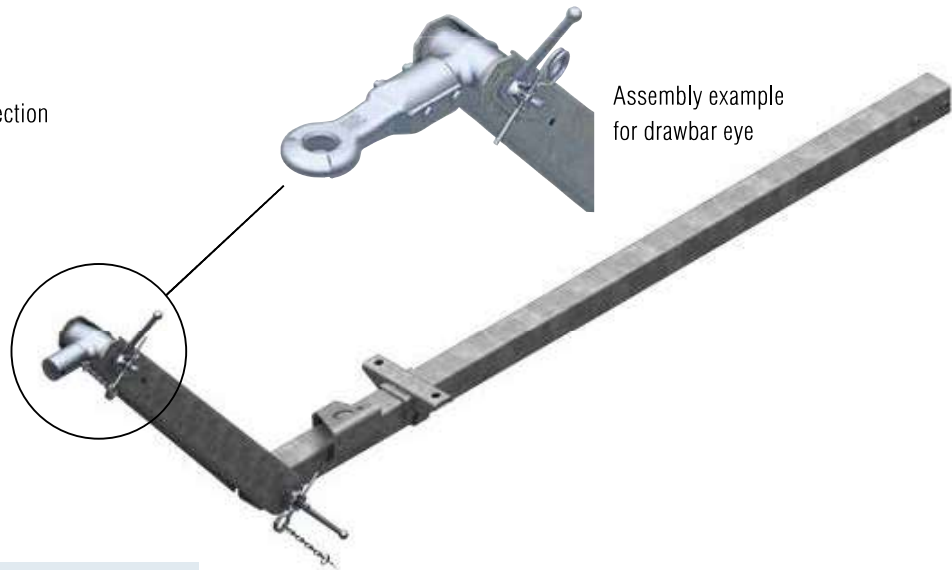

SAP: ZUGV ZSHB 75VU M DEICHSELPR

Drawbar cpl. with drawbar section mounted (without hitch components)

Part no.	Drawbar length E in mm	Total length K (at 0°) mm with DIN drawbar eye D40				
200 575 01	920	1,929	19.9	9	–	10
200 575 02	1,000	2,009	20.6	9	–	10
200 575 03	1,080	2,089	21.3	9	–	10
200 575 04	1,160	2,169	22	9	–	10
200 575 05	1,240	2,249	22.6	9	–	10
200 575 06	1,320	2,329	23.3	9	–	10
200 575 07	1,400	2,409	24.0	9	–	10
200 575 08	1,480	2,489	24.7	9	–	10
200 575 09	1,560	2,569	25.4	9	–	10
200 575 10	1,640	2,649	26.1	9	–	10
200 575 11	1,720	2,729	26.7	9	–	10
200 575 12	1,800	2,809	27.4	9	–	10
200 575 13	1,880	2,889	28.1	9	–	10
200 575 14	1,960	2,969	28.8	9	–	10
200 575 15	2,040	3,049	29.5	9	–	10
200 575 16	2,120	3,129	30.1	9	–	10
200 575 17	2,200	3,209	30.8	9	–	10
200 575 18	2,280	3,289	31.5	9	–	10
200 575 19	2,360	3,369	32.2	9	–	10
200 575 20	2,440	3,449	32.9	9	–	10
200 575 21	2,520	3,529	33.6	9	–	10
200 575 22	2,600	3,609	34.2	9	–	10
200 575 23	2,680	3,689	34.9	9	–	10
200 575 24	2,760	3,769	35.6	9	–	10
200 575 25	2,840	3,849	36.3	9	–	10

Drawbar cpl. with drawbar section mounted (without hitch components), special variant with parking brake mounted

200 575 26	1,960	2,969	30.8	9	–	10
------------	-------	-------	------	---	---	----

Push-on hitch components: Drawbar eye connection D50 / 75 VU

Hitch
AK 161 - Ø 50
 Part no. 1 730 808

Drawbar eyes
England E30/A
 Part no. 1 224 106

Drawbar eyes
DIN D40/F
 Part no. 1 213 350

Drawbar eyes
England E40/A
 Part no. 1 224 107

Drawbar eyes
Italy I45/F
 Part no. 1 224 108

Drawbar eyes
DIN D50
 Part no. 1 730 612

Drawbar eyes
England E50/A
 Part no. 1 224 109

Drawbar eyes
Sweden VBG 57.5
 Part no. 1 225 076

Drawbar eyes
France F68/E
 Part no. 1 224 110

Drawbar eyes
NATO N76/E
 Part no. 1 224 111

2

Refer to chapter 5 for drawbar eye illustrations and descriptions

IMPORTANT!

The hitch components and drawbar eyes have multiple uses. With this unbraked drawbar, the spacer sleeves included in the scope of delivery can be disregarded during assembly.

SURFACE TREATMENT

- || Hot-dip galvanised
- || Hitches, eyes and small parts galvanised

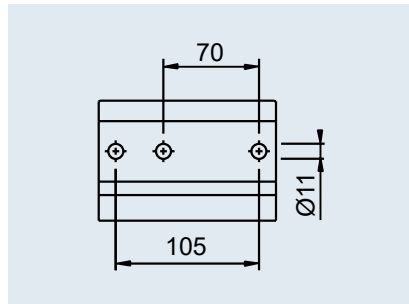

Jockey wheel flange

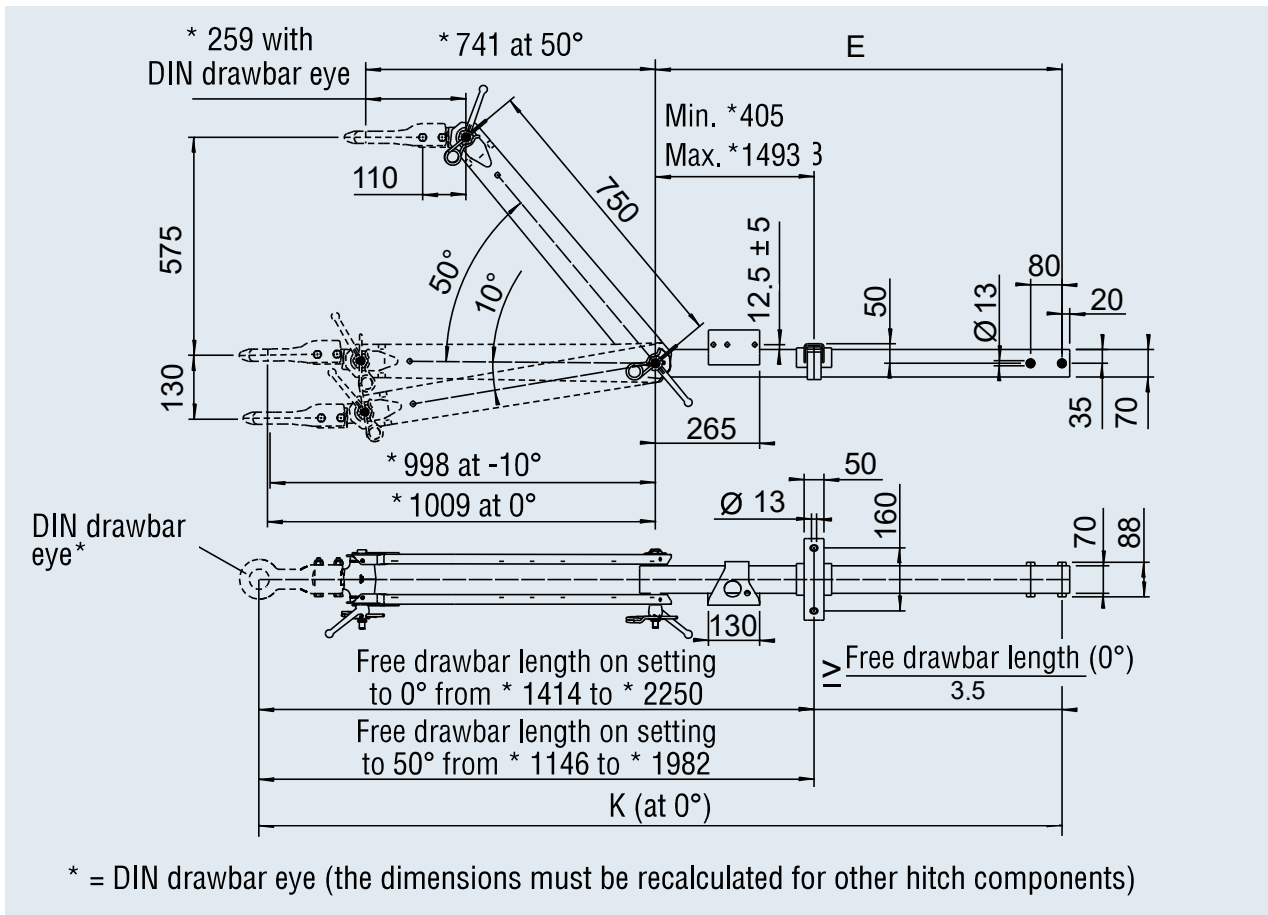

* = DIN drawbar eye (the dimensions must be recalculated for other hitch components)