

TOWBAR CONNECTION TOOTHED WASHER 102 VB

Height-adjustable with drawbar section up to 1,100 kg



TECHNOLOGY

Drawbar type 102 VB vers. N

Intermediate piece with drawbar section

Permitted nose load 100 kg

ECE type approval no.:

E1 55R-01 0211

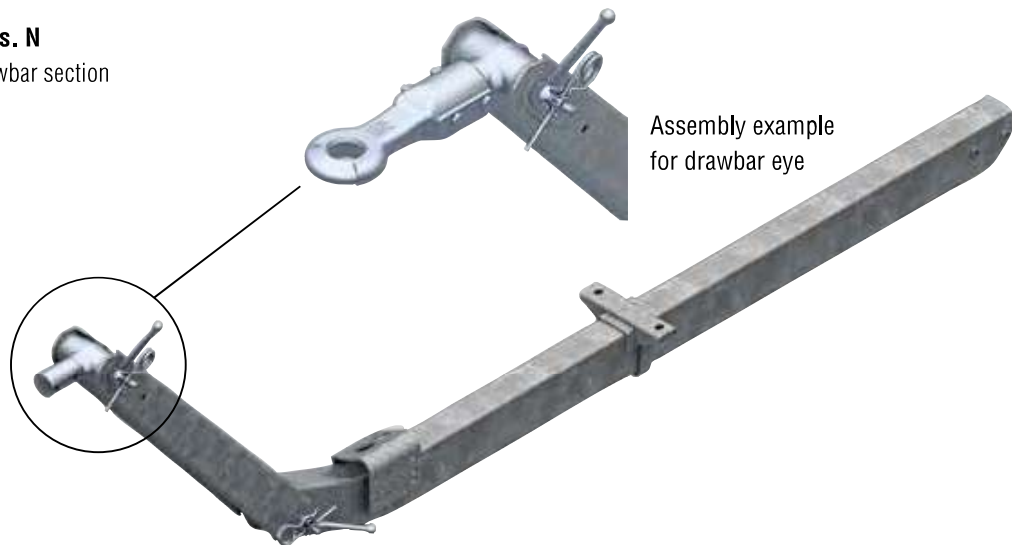

SAP: ZUGV ZSHB 102VB M DEICHSELPR

Drawbar cpl. with drawbar section mounted (without hitch components)

Part no.	Drawbar length E in mm	Total length K (at 0°) mm with DIN drawbar eye D40				
200 576 01	1,010	2,019	34.8	9	–	10
200 576 02	1,090	2,099	35.6	9	–	10
200 576 03	1,170	2,179	36.4	9	–	10
200 576 04	1,250	2,259	37.2	9	–	10
200 576 05	1,330	2,339	38.1	9	–	10
200 576 06	1,410	2,419	38.9	9	–	10
200 576 07	1,490	2,499	39.7	9	–	10
200 576 08	1,570	2,579	40.5	9	–	10
200 576 09	1,650	2,659	41.3	9	–	10
200 576 10	1,730	2,739	42.1	9	–	10
200 576 11	1,810	2,819	42.9	9	–	10
200 576 12	1,890	2,899	43.7	9	–	10
200 576 13	1,970	2,979	44.5	9	–	10
200 576 14	2,050	3,059	45.3	9	–	10
200 576 15	2,130	3,139	46.1	9	–	10
200 576 16	2,210	3,219	46.9	9	–	10
200 576 17	2,290	3,299	47.7	9	–	10
200 576 18	2,370	3,379	48.5	9	–	10
200 576 19	2,450	3,459	49.3	9	–	10
200 576 20	2,530	3,539	50.2	9	–	10
200 576 21	2,610	3,619	51	9	–	10
200 576 22	2,690	3,699	51.8	9	–	10
200 576 23	2,770	3,779	52.6	9	–	10
200 576 24	2,850	3,859	53.4	9	–	10

Drawbar cpl. with drawbar section mounted (without hitch components), special variant with parking brake mounted

200 576 26	1,970	2,979	46.5	9	–	10
------------	-------	-------	------	---	---	----

Push-on hitch components: Drawbar eye connection D50 / 102 VB

Hitch
AK 161 - Ø 50
Part no. **1 730 808**

Drawbar eye
England E30/A
Part no. **1 224 106**

Drawbar eyes
DIN D40/F
Part no. **1 213 350**

Drawbar eyes
England E40/A
Part no. **1 224 107**

Drawbar eye
Italy I45/F
Part no. **1 224 108**

Drawbar eyes
DIN D50
Part no. **1 730 612**

Drawbar eyes
England E50/A
Part no. **1 224 109**

Drawbar eyes
Sweden VBG 57.5
Part no. **1 225 076**

Drawbar eyes
France F68/E
Part no. **1 224 110**

Drawbar eyes
NATO N76/E
Part no. **1 224 111**

2

Refer to chapter 5 for drawbar eye illustrations and descriptions

IMPORTANT!

- The hitch components and drawbar eyes have multiple uses.
In unbraked drawbars, the spacer sleeves supplied can be dispensed with during assembly.
- In the EC, the maximum permitted gross weight with an unbraked trailer is 750 kg.
The respective regulations in countries outside of the EU must be heeded.

SURFACE TREATMENT

- Hot-dip galvanised
- Hitches, eyes and small parts galvanised

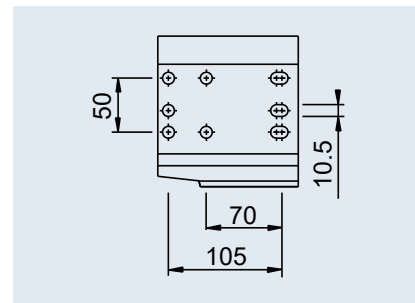

Jockey wheel flange

