

TOWBAR CONNECTION TOOTHED WASHER 162 VB

Height-adjustable with drawbar section up to 1,600 kg



TECHNOLOGY

Drawbar type 162 VB vers. M

Intermediate piece with drawbar section

Permitted nose load 100 kg

ECE type approval no.:

E1 55R-01 0212

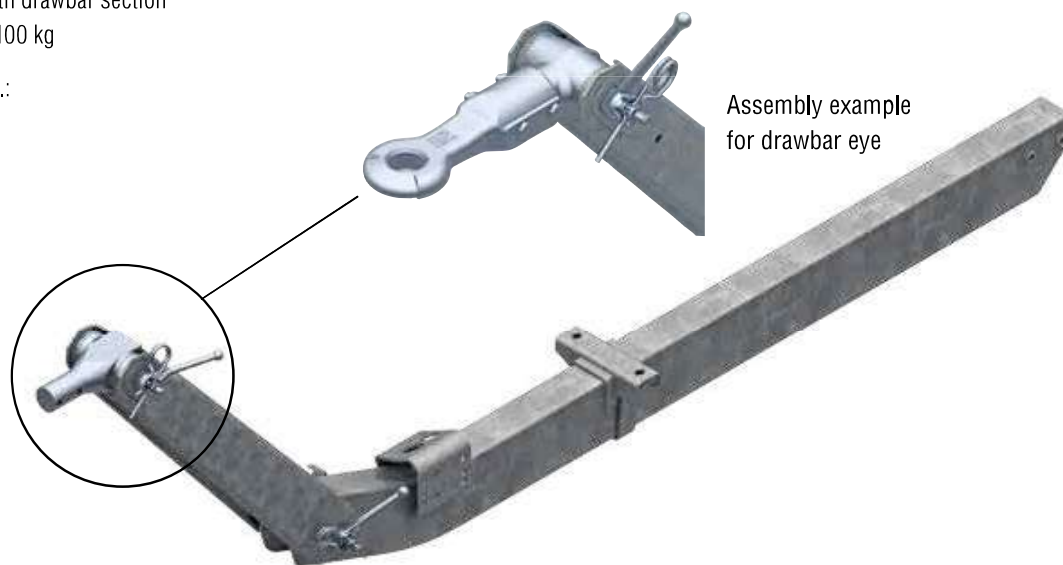

SAP: ZUGV ZSHB 162VB M DEICHELPR

Drawbar cpl. with drawbar section mounted (without hitch components)

Part no.	Drawbar length E in mm	Total length K (at 0°) mm with DIN drawbar eye D40				
200 577 01	1,250	2,302	54.1	9	–	10
200 577 02	1,330	2,382	55.2	9	–	10
200 577 03	1,410	2,462	56.3	9	–	10
200 577 04	1,490	2,542	57.4	9	–	10
200 577 05	1,570	2,622	58.6	9	–	10
200 577 06	1,650	2,702	59.7	9	–	10
200 577 07	1,730	2,782	60.8	9	–	10
200 577 08	1,810	2,862	61.9	9	–	10
200 577 09	1,890	2,942	63	9	–	10
200 577 10	1,970	3,022	64.1	9	–	10
200 577 11	2,050	3,102	65.2	9	–	10
200 577 12	2,130	3,182	66.3	9	–	10
200 577 13	2,210	3,262	67.4	9	–	10
200 577 14	2,290	3,342	68.6	9	–	10
200 577 15	2,370	3,422	69.7	9	–	10
200 577 16	2,450	3,502	70.8	9	–	10
200 577 17	2,530	3,582	71.9	9	–	10
200 577 18	2,610	3,662	73	9	–	10
200 577 19	2,690	3,742	74.1	9	–	10
200 577 20	2,770	3,822	75.2	9	–	10
200 577 21	2,850	3,902	76.3	9	–	10

Drawbar cpl. with drawbar section mounted (without hitch components), special variant with parking brake mounted

200 577 22	1,970	3,022	69.1	9	–	10
------------	-------	-------	------	---	---	----

Push-on hitch components: Drawbar eye connection D50 / 162 VB

