

LANZA ARTICULADA, MODELO 501 VB

para remolques con freno neumático 5.000 kg



TÉCNICA

Modelo de lanza de remolque 501 VB

vers. A

Pieza intermedia con tubo

Carga en bola 500 kg

N.º de homologación de modelo ECE:

E1 55R-01 0883

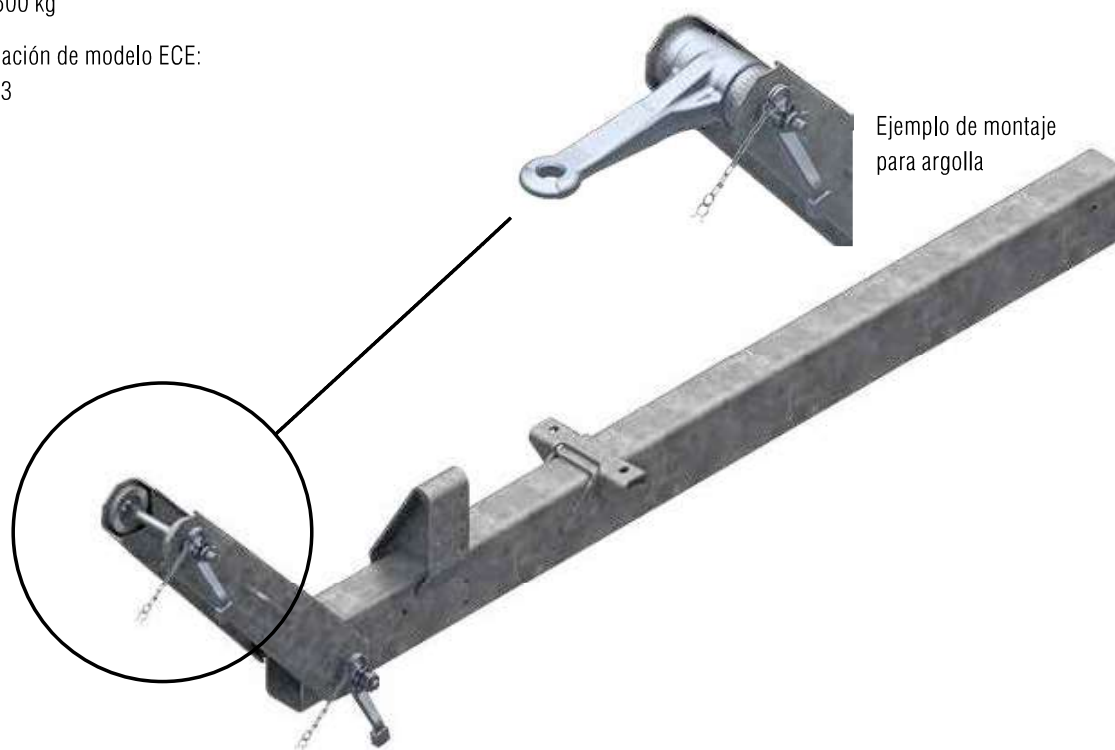

Ejemplo de montaje para argolla





TRATAMIENTO DE LA SUPERFICIE

| Galvanizado en caliente

| Cabezales, argollas y piecerío cincados

SAP: ZUGDEICHS KPL 501VB

Lanza de remolque compl. con tubo montado (sin elementos de acoplamiento)

N.º de ref.	Longitud de lanza E mm	Longitud total K (con 0°) mm con argolla DIN D40				
200 615 21	1.970	3.100	155	10	–	10
200 615 22	2.130	3.260	162	10	–	10
200 615 23	2.290	3.420	169	10	–	10
200 615 24	2.450	3.580	176	10	–	10
200 615 25	2.610	3.740	183	10	–	10

Elementos de acoplamiento: argollas conexión D60 / 501 VB

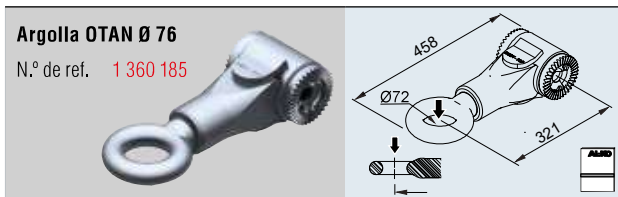
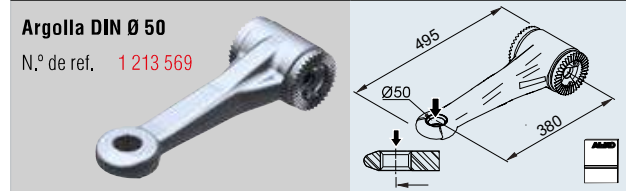
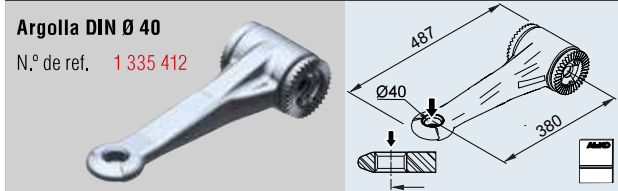

2

