

ESSIEU BASIC 1 300 KG NON FREINÉ

112x5



TECHNIQUE

Modèle : BASIC
 Type d'essieu : UBR 1200-5
 Charge à l'essieu : SOLO 1 300 kg
 Suspension : Suspension hexagonale
 caoutchouc
 Tourillon : 161,5 mm
 Perçage : 112x5
 Roulement : Roulement compact
 Trou central jante : mini 57 mm

CONTENU DE LA LIVRAISON

┃ Vis de roue en vrac
 ┃ Mode d'emploi

TRAITEMENT DE SURFACE

┃ Corps d'essieu galvanisé



SAP: ACHSE GU UBR EA 1300 PLUS

Essieu solo 112x5

Vis de roue sphériques
 M 12x1,5

Essieu complet	Voie en mm	EAB en mm				
200 561 01	1 200	750	33	–	30	10
200 561 02	1 250	800	33	–	30	10
200 561 03	1 300	850	33	–	30	10
200 561 04	1 350	900	34	–	30	10
200 561 05	1 400	950	34	–	30	10
1 222 364	1 450	1 000	34	–	30	10
200 561 06	1 490	1 040	34	–	30	10
200 561 07	1 520	1 070	35	–	30	10
200 561 08	1 550	1 100	35	–	30	10
200 561 09	1 600	1 150	35	–	30	10
200 561 10	1 650	1 200	35	–	30	10
200 561 11	1 670	1 220	36	–	30	10
200 561 12	1 700	1 250	36	–	30	10
200 561 13	1 760	1 310	36	–	30	10
200 561 14	1 800	1 350	36	–	30	10
200 561 15	1 850	1 400	36	–	30	10
200 561 16	1 900	1 450	37	–	30	10
200 561 17	1 950	1 500	37	–	30	10
200 561 18	1 980	1 530	37	–	30	10
200 561 19	2 000	1 550	37	–	30	10
200 561 20	2 030	1 580	37	–	30	10
200 561 21	2 075	1 625	38	–	30	10
200 561 22	2 120	1 670	38	–	30	10
200 561 23	2 150	1 700	38	–	30	10
200 561 24	2 200	1 750	38	–	30	10
200 561 25	2 250	1 800	38	–	30	10
200 561 26	2 300	1 850	38	–	30	10
200 561 27	2 350	1 900	38	–	30	10

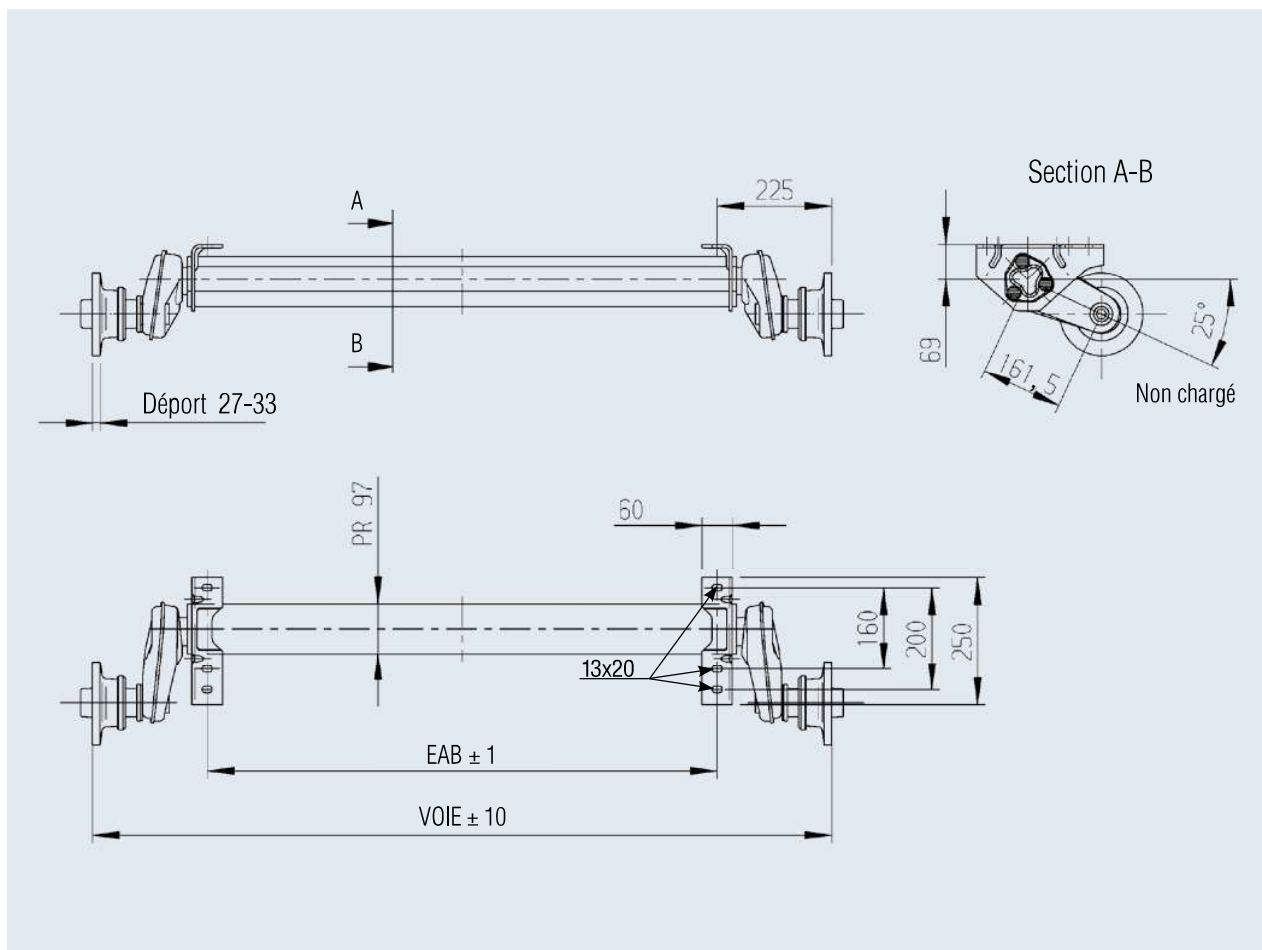

Accessoires pour liaisons timon/essieu boulonnables

Code article 247 684

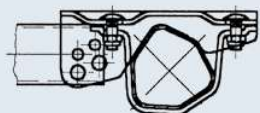

Liaisons timon/essieu possibles :

- I Ø 70
- I Ø 88,9
- I Ø 101,6
- I ☒ 60x60
- I ☒ 70x70
- I ☒ 100x100

Code article 249 117

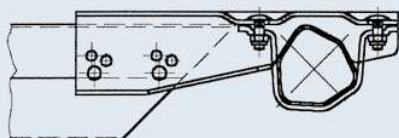

Liaisons timon/essieu possibles :

- I ☒ 80x140
- I ☒ 80x160
- I ☒ 100x160
- I ☒ 100x177
- I ☒ 120x120
- I ☒ 120x160
- I ☒ 120x177