



KIT LUBE



DISPENSERS



PUMPS



METERS



NOZZLE METERS



NOZZLES

K600/3

FEATURES

- ADJUSTABLE FLANGES
- EXTREMELY ACCURATE
- SUITABLE FOR INDUSTRIAL APPLICATIONS
- IDEAL FOR MOBILE INSTALLATIONS
- LOW ENERGY CONSUMPTIONS

The Piusi K600/3 is an oval gear meter suitable for monitoring the delivery of low, medium and high viscosity oils. The meter is equipped with an integrated filter and it is available also in pulser version.

PERFORMANCE

up to

100 L/MIN

(up to 26,4 gpm)

FLOW RATE

± 0,5 %

ACCURACY

0,2%

REPEATABILITY

30/70BAR

PRESSURE



K600/3



K600/3 PULSER

PACKAGING

CODE	WEIGHT		PACKAGING			
	KG	LBS	MM	INCH	PCS/PALLET	PCS/BOX
METERS						
FO0496A20	1,6	3,5	200X120X140	7,9X4,7X5,5		1
PULSER						
FO0472A20	2	4,4	200X120X140	7,9X4,7X5,5		1



WASTE OIL EQUIPMENTS



FILTRATION



FLUID MONITORING



HOSE REELS



ACCESSORIES



MERCHANDISE

INDEX



AIR



ANTIFREEZE



AdBlue®



BIODIESEL



DIESEL



FOOD



GASOLINE



GREASE



KEROSENE



OIL



WATER



WINDSCREEN

CHARTS

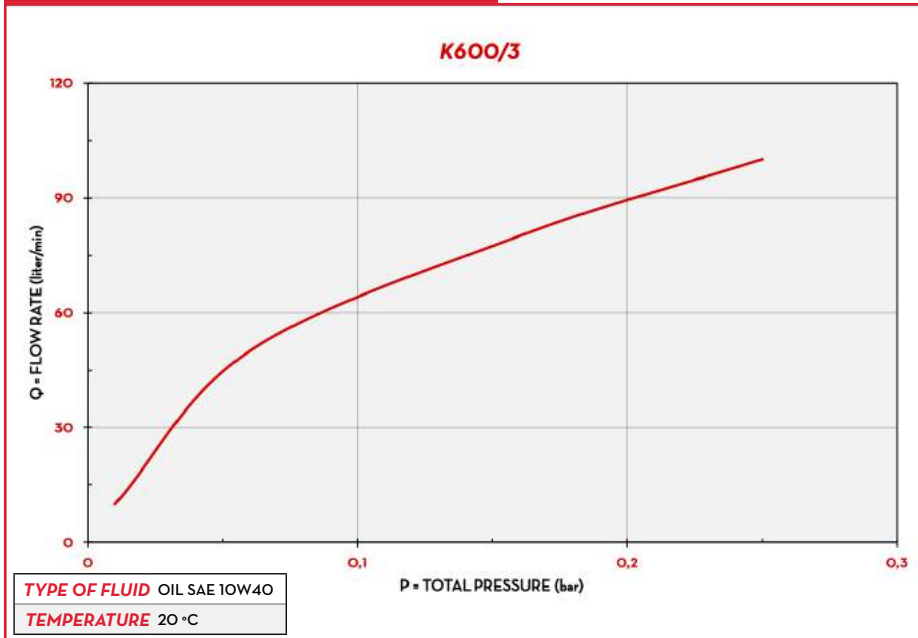

IN THE BOX

- K600/3 METER
- INSTRUCTION MANUAL

DETAILS



RESET / CALIBRATE BUTTON



ALLUMINIUM BODY



OVAL GEAR

DIMENSIONS

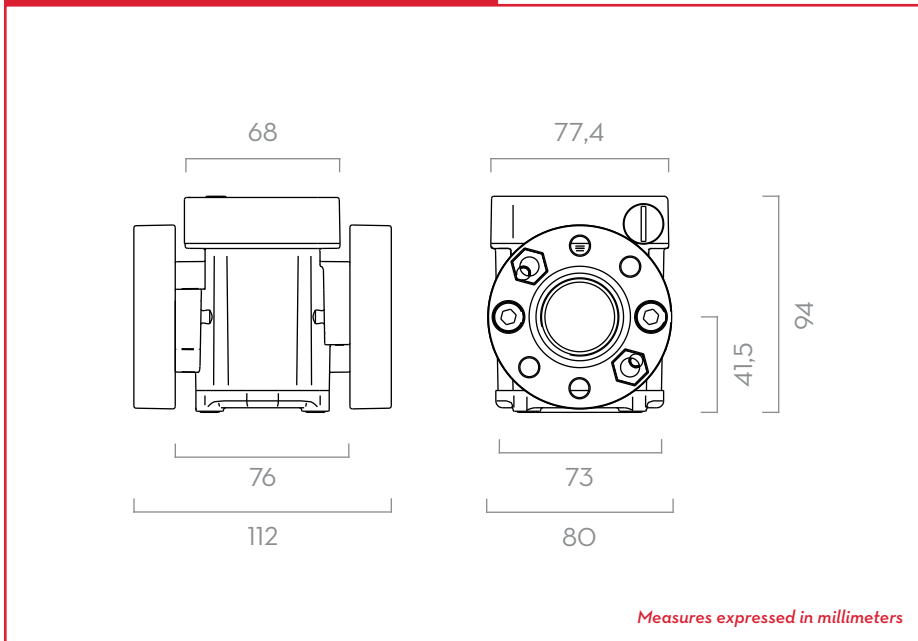

MATERIALS

- BODY: ALLUMINIUM
- GEARS: TECHNOPOLYMER

TECHNICAL DATA

CODE	DESCRIPTION	FLUIDS TYPE	FLOW-RATE		WORKING PRESSURE		BATTERY INCLUDED NO. 2 2X1,5V	FLANGE	INLET OUTLET	INLET FILTER
			L/MIN	GPM	BAR	PSI				
METERS										
FOO496A20	K600/3 OIL		6 - 60	1,58 - 1,58	70	994	YES	YES	3/4" BSP	YES
PULSER										
FOO472A20	K600/2-3 3/4" OIL		6 - 60	1,58 - 1,58	70	994	NO	YES	3/4" BSP	YES

UPON REQUEST AVAILABLE IN NPTF VERSION AND DISPLAY IN GALLON/QUARTER OR PRINT

K600/3