

Steadicam X3

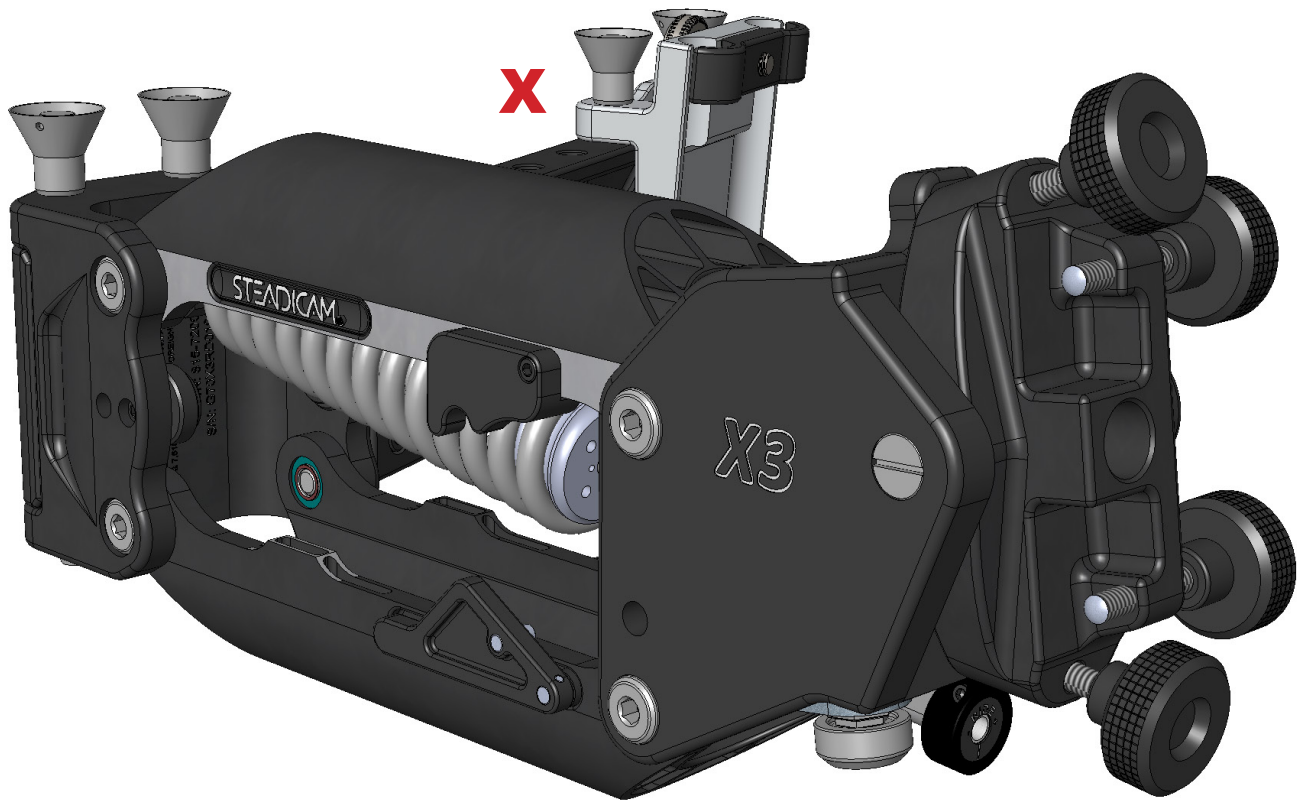

LIT-077200

STEADICAM®

Table of Contents

Introduction	1
X3 Components	2
Installation	3
Putting it on	5
Lift and Threads	7
Ride Adjustment	9
Goofy Setup	11
Other considerations	13
Maintenance	14
Contact Tiffen	15



The Tiffen Company
90 Oser Avenue
Hauppauge, NY 11788
Visit us at www.tiffen.com

The Steadicam X3:

Building on the strength and versatility of the Fawcett Exovest, the Steadicam X3 expands your ability to place the camera anywhere you wish. The additional 50% boom range over the G-70X brings the Steadicam arm almost equal to the gripping range of most operators. You now have nearly four feet of boom range to work with at all times! This translates to fewer switches to low-mode or back to high mode for that special shot. And the lens can get higher or lower than ever before.

The patented design of the X3 utilizes the symmetrical rods of the Exovest to attach like a back-mounted vest. No changes are required to mount any standard arm. Once the X3 is set to your preferred side and width, it is quickly added or removed from the vest, without tools. The operator can adjust arm alignment as well as adjust the lift and ride settings of all three arm sections without need of assistance.

Best of all, you are now free to place the camera anywhere within an expanded range and create shots that were previously difficult or impossible.

Caution: the unloaded arm is shipped and stored under tension when held by the arm lock. NEVER place fingers or objects within the arm sections in case the arm releases unexpectedly.

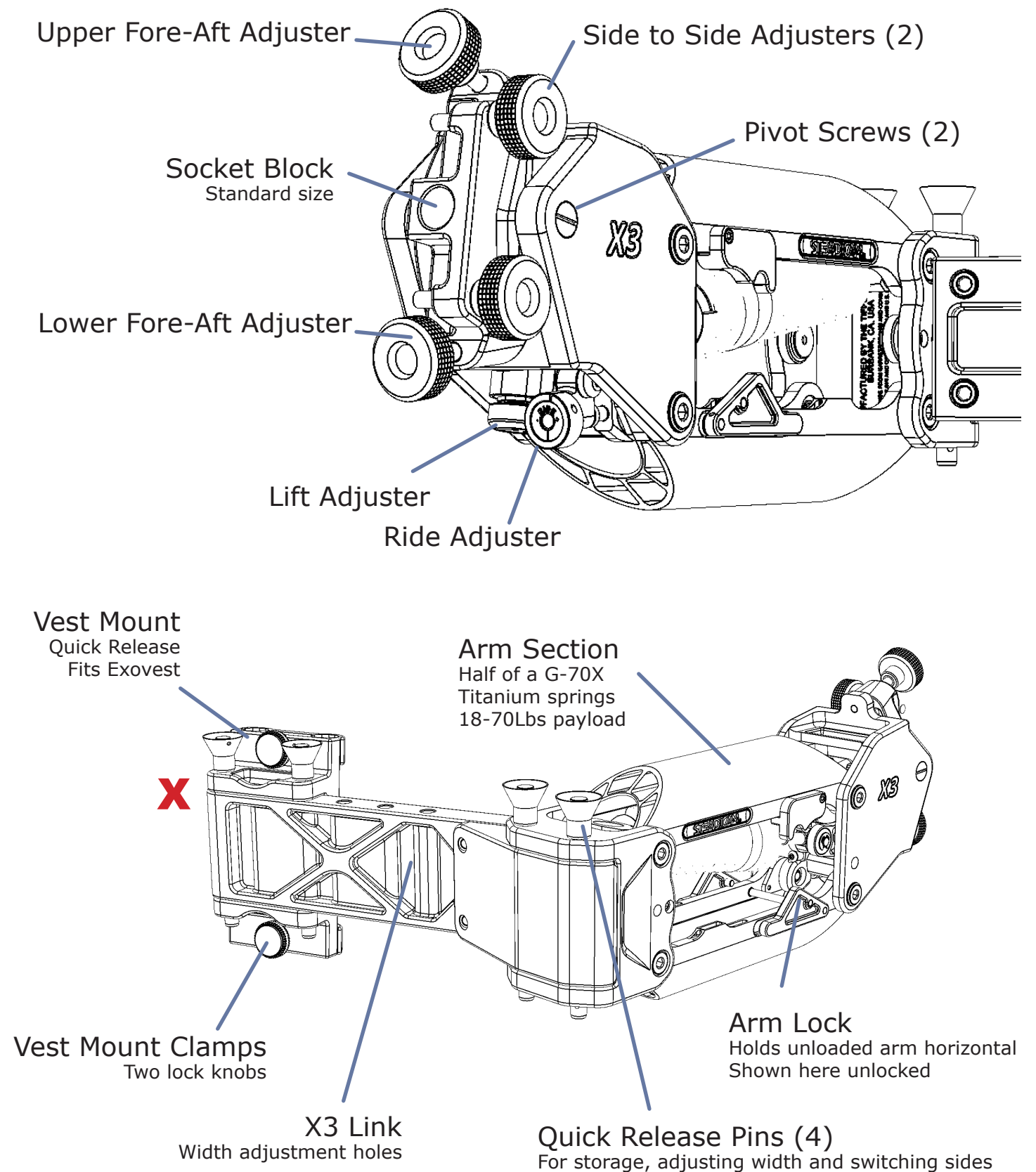

Installation

Putting it all together:

Before you go any further, make sure you have your traditional kit set up. Your 2-section arm front-mounted on the Exovest, arm dialed in for lift and ride (if applicable) and the rig precisely balanced. This will make adding the X3 much easier, since you will only have to make adjustments to the 3rd arm section once it's on the vest.

Attaching the X3 to the Exovest is a tools free affair. And once you find your settings, switching from front-mount to X3 should take less than 5 minutes in the field.



Tighten both clamp knobs by hand with enough torque that the mount won't slide.

Remove the Exovest bridge plate to improve clearance and reduce weight.

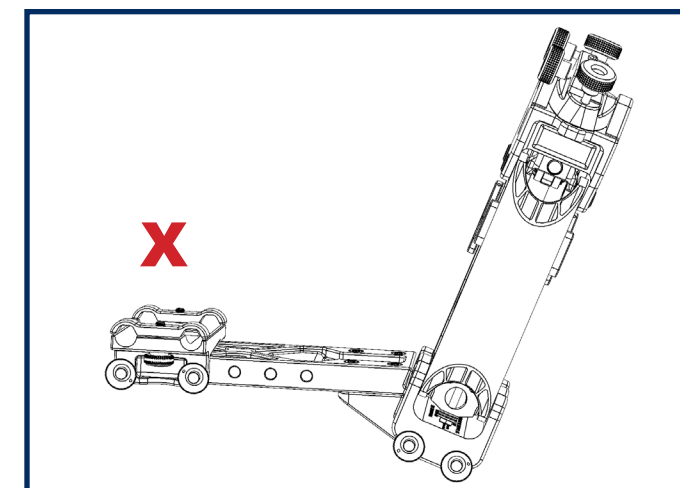
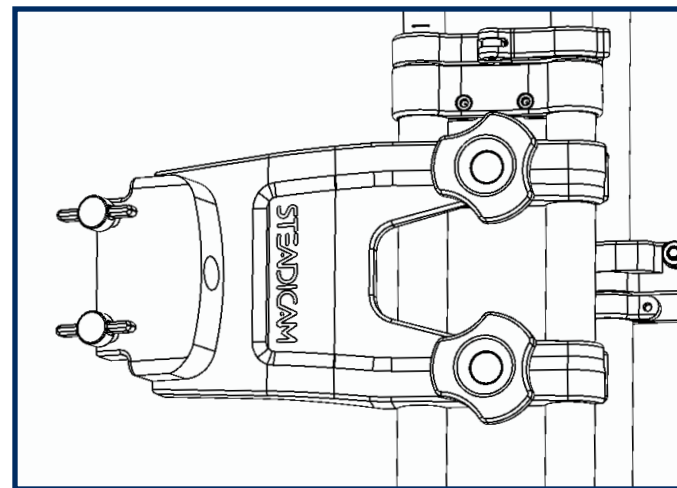

With the waist latch of your vest closed, check that the inside of the arm section lines up just OUTSIDE of the waist pads.

The closer it is, the narrower your entire setup will be, but you don't want the X3 to contact the vest.

Like the bridge plate, separate the X3 rod clamps and place them around the REAR rods of the vest with the arm section on the right side.

If you prefer to fly goofy, check page 11 to flip the X3 and then come back here.

Note: the vest mount is not symmetrical top to bottom. The THIN end goes up, tilting the X3 slightly downward.

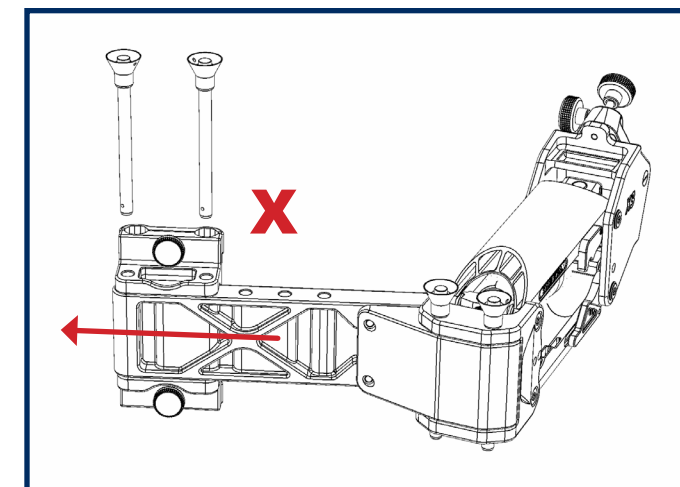
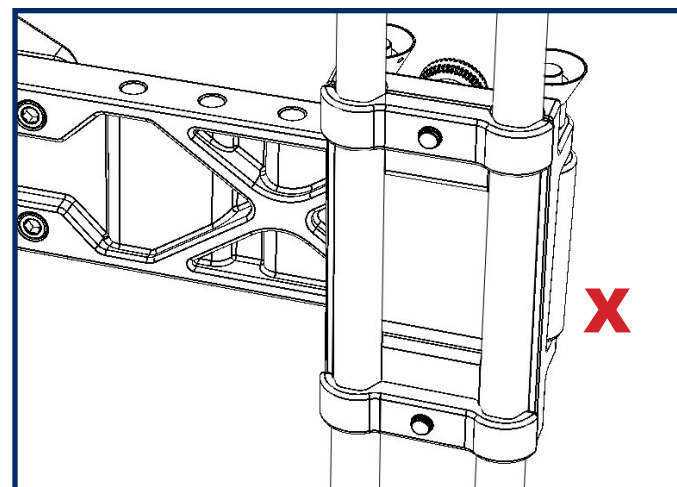

If it's either too wide or too narrow, pull the two vest mount quick release pins and choose another set of holes in the link so the arm is ideally positioned. Re-install the pins.

Climbing in

Make sure the arm is locked horizontal and the fore-aft adjusters are not loose before putting on the vest.



The vest will be heavy, so placing it on a cart or lift-gate can help entry.

An assistant can be a big help the first few times you climb in.



Hold onto the arm section with your right hand as you climb in, lifting the shoulders into place with your left. Secure the shoulder dovetail and then move on to the waist.

Caution: the unloaded arm is under tension when held by the arm lock. NEVER place fingers or objects within the arm sections in case the arm releases unexpectedly.



Add your arm

Cinch down the vest like normal. It should not need to be adjusted from your usual setup despite the added weight.



Add your 2-section arm at the socket block and lock it in with the side-to-side adjusters.

If this is your initial setup, you'll need to set the lift and ride, plus find your threads.

If you already know your threads, set them before hoisting the rig.



Pick up your sled and flip open the arm lock to free up the 3rd section.



Lift and threads

Like any G-series arm, Lift is only adjustable with the arm slightly above horizontal. You'll need to raise or lower the sled to find that sweet spot.

A normal lift setting will allow all THREE arm sections to move together with a slight tendency to remain horizontal.



With the X3 held just above horizontal, you'll feel the knob unlock. Adjust the X3 lift to support your rig and 2-section arm.



The side-to-side adjustment rotates the socket block similar to the fore-aft adjustment on a traditional mount.

However, we must adjust the side-to-side threads without the rig on board.

Wear the rig and observe which direction it tends to pull, then dock.



Lift and threads

To make a side-to-side adjustment, loosen the top knob, make your adjustment with the lower knob and re-snug the top.

Test and repeat until the rig is centered.

Remember, these screws lock the 2-section arm socket to the X3 socket block, so make sure they're snug.

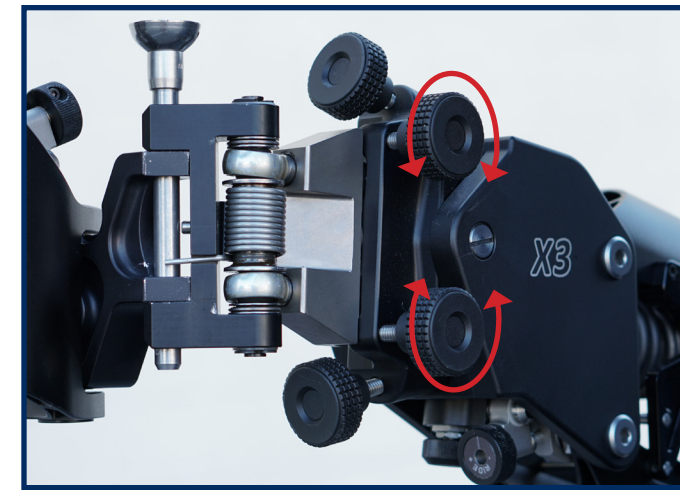

The fore-aft adjustment uses the pair of knobs facing forward to rotate the entire socket block around the pivot screws.

Similar to the side-to-side adjustment, we'll have to turn the knobs without the rig on board.

Wear the rig and decide which direction you need to adjust the fore-aft knobs, then dock.



To make a fore-aft adjustment, loosen the top knob, make your adjustment with the lower knob and re-snug the top.

Test with the rig on board and repeat if necessary.

If you run out of adjustment range on X3 fore-aft, reach for your 1/4" Allen wrench and make adjustments to your 2-section arm rod-ends.

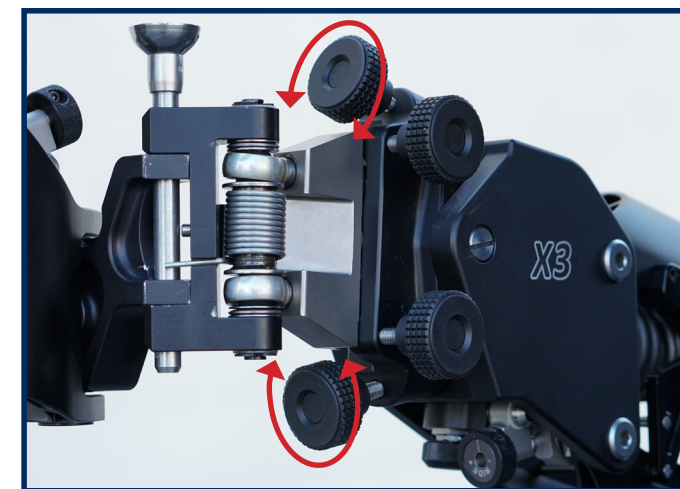

Ride adjustment

Nice ride:

Next we move on to the ride setting, or the ISO-elastic behavior of the arm. If you're not familiar with this process, don't worry. The goal is to make all three arm sections work together and be as ISO-elastic as possible for your payload.

Note: like any G-series arm, the X3 ride is only adjustable with the arm at the TOP of its travel. Due to the tremendous boom range of the combined three arm sections, you may want the help of an assistant, or you'll want to dock without the arm lock just while setting the ride adjustments.

Fly the rig and take note of how the X3 responds to booming.

Does it follow your 2-section arm?

Does X3 lock at the top or bottom?

If it's perfect, great, go to work. If it's not perfect, take a few minutes to dial it in.



To make an adjustment, dock the rig WITHOUT using the arm lock. It will be awkward, but will allow you to dial the ride knob by yourself.

If you have an assistant, you can boom all the way up and have them make the adjustment for you. Just ask nicely.

Make your adjustment and then re-test with the rig.



Ride adjustment

If the X3 is locking at the top of the travel, skip to the next step.

Otherwise, turn the ride knob counter-clockwise (more ISO) until the arm segment begins to "lock" up or down when boomed.

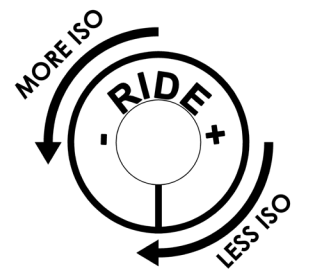

Then, turn the ride knob clockwise a turn or two until the arm ceases to lock up.

The X3 will typically require LESS ISO than a G-70X attached to it. Fewer threads will be showing behind the ride knob on your X3.

Test and micro adjust the lift and ride as necessary so all three arm sections follow each other.

All three sections should move at the same time, at the same angles and not require much force.

For more details about lift and ride adjustments, see the G-70X manual online at: <https://tiffen.com/steadicam/product-literature/>



Goofy setup

If you're feeling goofy:

Flipping the X3 to the left side only takes a couple of minutes. Most of it is accomplished by removing the quick release pins, but you'll need a flat-head screwdriver to remove the pivot screws and flip the socket block. In a pinch, you could run your arm socket on the "regular" side and leave the X3 regular as well. But let's do it right this time.

Pull all four quick release pins (they're identical) and separate the 3 main components of the X3.

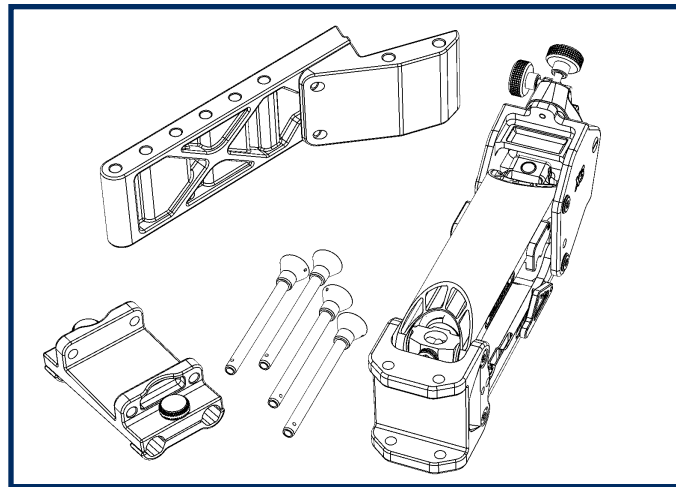

Reassemble the pieces with the link and the arm to the LEFT of the vest mount, as shown.

Note: the vest mount is not symmetrical top to bottom. The THIN end goes up, tilting the X3 slightly downward.

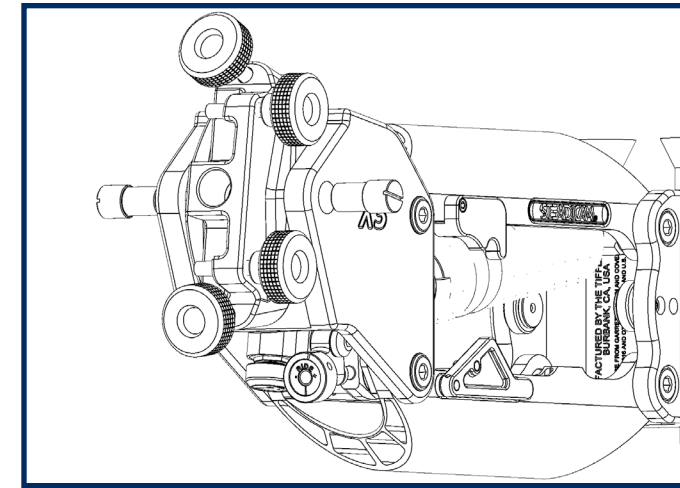
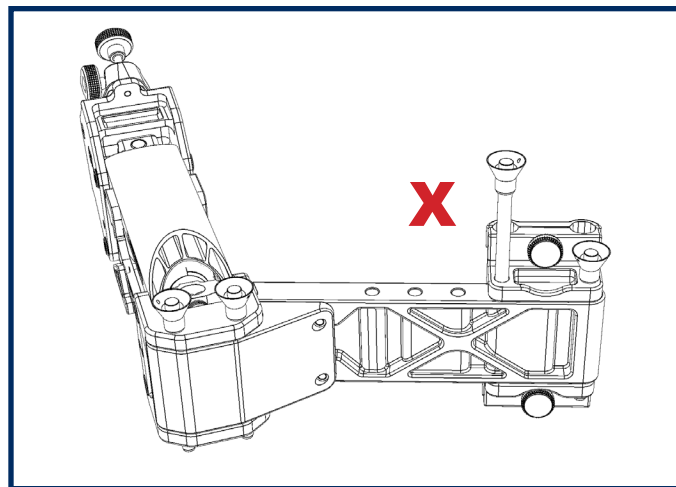

Remove the two pivot screws and set them aside.

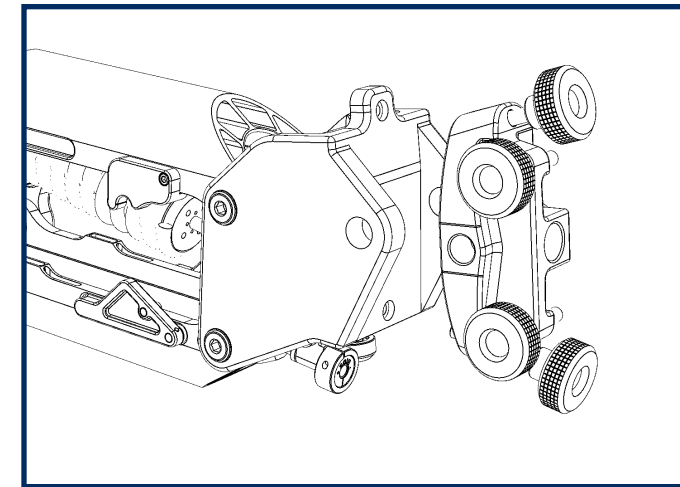

Remove and flip the socket block 180° so the side-to-side adjusters are facing INWARD, toward the operator.

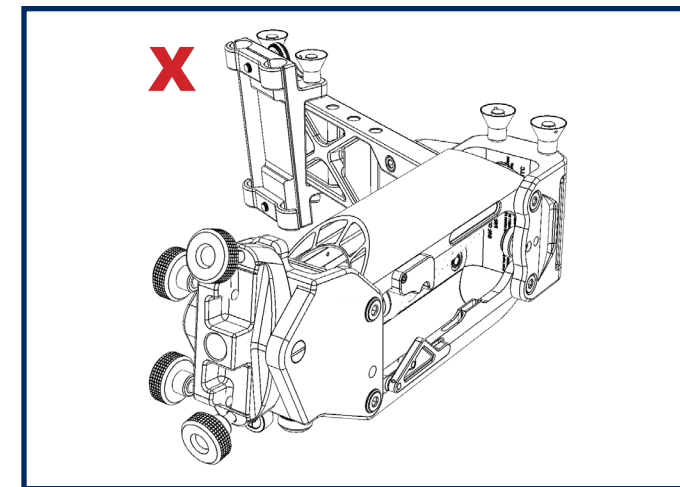

Reinstall the two pivot screws and center the fore-aft adjuster screws to get you started.

Remember to check the overall width once you attach the X3 to your vest.

Other considerations

Always use the arm lock on the X3 before docking and decoupling your 2-section arm. It is nearly impossible to force the arm down without the weight of a sled.

It IS possible to use the X3 without engaging the arm lock, but it makes joining your arm more difficult. And who wants that?



Consider leaving the vest mount on the back rods at all times and simply use the QR pins to add the X3 in seconds.



You might use high-low-mode more than normal. Build your sled extra short in order to get maximum lens height indoors.

Experiment with that expanded boom range!



Maintenance

Clean the X3 with a lint-free cloth misted with household window cleaner.

The steel and aluminum finishes are extremely durable and may be cleaned with isopropyl alcohol, in case you need to remove serious gunk.

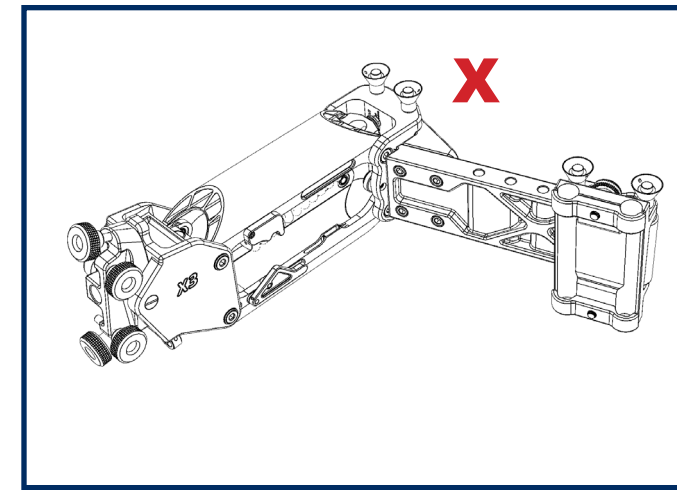

Check the arm section after each shoot for smooth, silent operation.

Make sure all hardware is maintained and contact Tiffen for spares or repairs.

Note: DO NOT lubricate anything on the X3, including the bearings or spring ends.

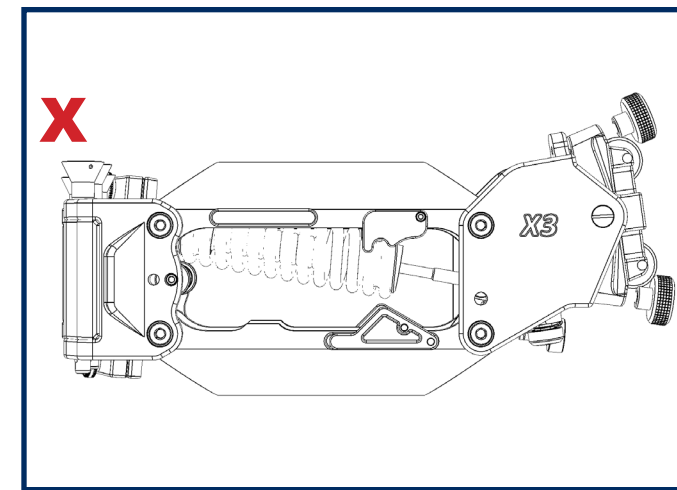

Make sure the X3 is completely dry before storage and transport.

And be careful never to place fingers or objects inside the arm sections when the X3 is under tension, held by the arm lock.

Store the X3 in the included soft bag.

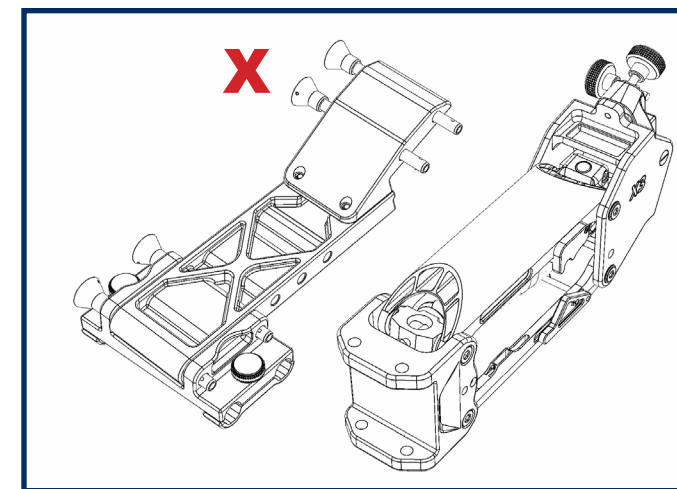

Contact Tiffen

The Tiffen Company

90 Oser Avenue

Hauppauge, NY 11788

Phone: (631) 273-2500 or 1(800) 645-2522

Fax: (631) 273-2557

Tiffen-Steadicam

2815 Winona Avenue

Burbank, CA 91504

Phone: (818) 843-4600 or 1(800) 593-3331

Fax: (818) 843-8321

Tiffen International Ltd.

Pinewood Studios

Pinewood Road

Iver Heath SLO ONH

United Kingdom

Phone: (44) 870-1001220

Fax: (44) 1869-321766

Email:

techsupport@tiffen.com

Web:

tiffen.com/steadicam

Designed and manufactured in the United States of America.

Patents pending. Tiffen reserves the right to change specifications, accessories, etc. without prior notice. There is no implied or expressed warranty regarding this material.

STEADICAM®, Exovest®, G-70X™ and Iso-elastic are trademarks of the Tiffen Company, LLC.
© 2017 Tiffen Company, LLC. Written by E. Barthelman



