

Stelvoet 7601 3003 B2K

Stelvoet 7601 3009 B2K

ITEM NO.	PART NUMBER	DESCRIPTION	QTY.
1	203017-010-0010v0		1
2	203017-010-0011v0		1
3	203017-010-0012v0		1

UNLESS OTHERWISE SPECIFIED: DIMENSIONS ARE IN MILLIMETERS SURFACE FINISH: TOLERANCES: LINEAR: ANGULAR:		FINISH:	DEBURR AND BREAK SHARP EDGES	DO NOT SCALE DRAWING	REVISION
DRAWN	NAME	SIGNATURE	DATE	TITLE:	
CHK'D					
APPV'D					
MFG					
Q.A				MATERIAL: steel	DWG NO. 203017-010-0015v0
				WEIGHT: 107.66	SCALE: 1:3
					SHEET 1 OF 1

A3

Stelvoet 7601 3003 B2K

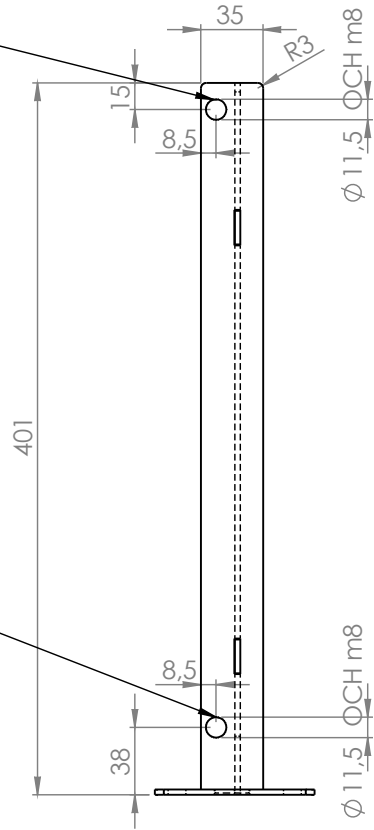

Stelvoet 7601 3009 B2K

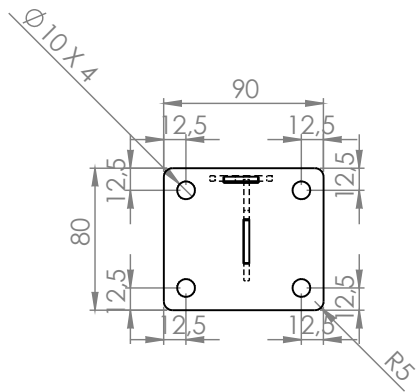
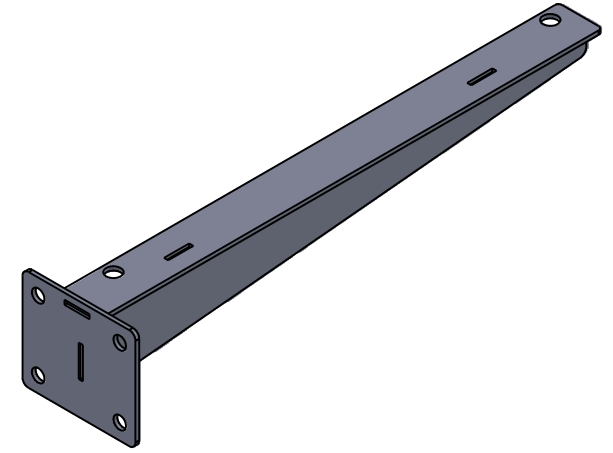
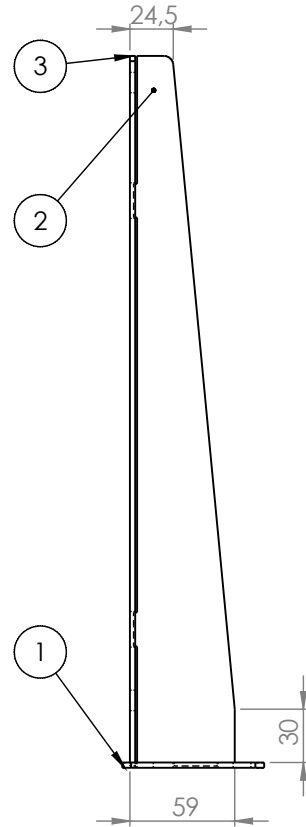
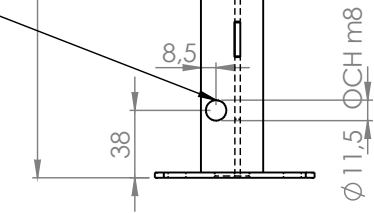

ITEM NO.	PART NUMBER	DESCRIPTION	QTY.
1	203017-010-0001v0		1
2	203017-010-0002v0		1
3	203017-010-0003v0		1

UNLESS OTHERWISE SPECIFIED: DIMENSIONS ARE IN MILLIMETERS SURFACE FINISH: TOLERANCES: LINEAR: ANGULAR:			FINISH:	DEBURR AND BREAK SHARP EDGES	DO NOT SCALE DRAWING	REVISION
DRAWN	NAME	SIGNATURE	DATE	TITLE:		
CHK'D						
APPV'D						
MFG						
Q.A				MATERIAL: STEEL	DWG. NO. 203017-010-0005v0 ^{A3}	
				WEIGHT: 107.66	SCALE: 1:3	SHEET 1 OF 1