

STEP 2 (continued)

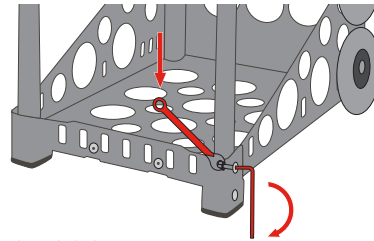

Insert the side bolts:

Starting with the sides of the wrapper will make the repair easier. Insert a 1.25" bolt through the side of the wrapper and frame. Hand tighten the 10mm lock nut to the bolt.

Use the 10mm combination wrench to firmly hold the 10mm lock nut. With your other hand, insert the 4mm Allen wrench into the bolt head and turn clockwise. Repeat on other side.

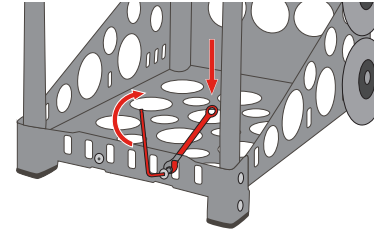

Insert the front screws:

Insert a 0.5" screw through the front of the wrapper and frame. Hand tighten the 8mm lock nut to the screw.

Use the 8mm combination wrench to firmly hold the 8mm lock nut. With your other hand, insert the 3mm Allen wrench into the bolt head and turn clockwise. Repeat with adjacent screw.

Congrats! You've successfully changed your front wrapper.

FRONT WRAPPER KIT INCLUDES:

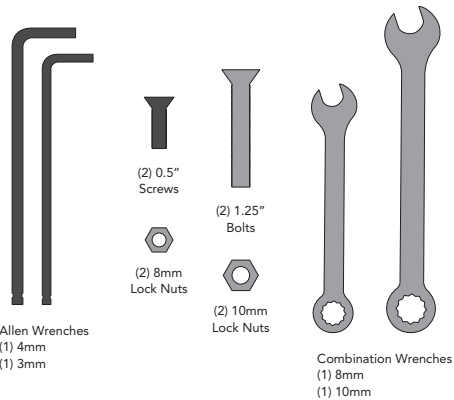

STEP 1 Removing the old front wrapper

Stop! Before you do anything else, remove the Insert from the frame. This will make the repair easier.

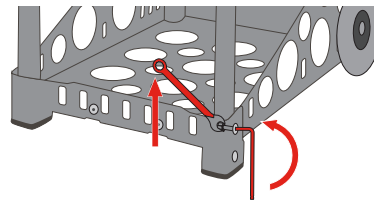

Remove the side bolts:

Start by removing the bolts on both sides of the wrapper. Use the 10mm combination wrench to firmly hold the lock nut. With your other hand, insert the 4mm Allen wrench into the bolt head and turn counterclockwise. Repeat on other side.

STEP 1 (continued)

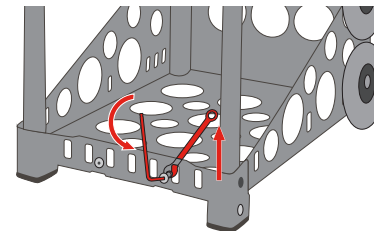

Remove the front screws:

Use the 8mm combination wrench to firmly hold the lock nut. With your other hand, insert the 3mm Allen wrench into the screw head and turn counterclockwise. Repeat with adjacent screw. Then separate the wrapper from the frame.

You can discard the old hardware after you've removed it. You won't need it anymore.

STEP 2 Attaching the new front wrapper

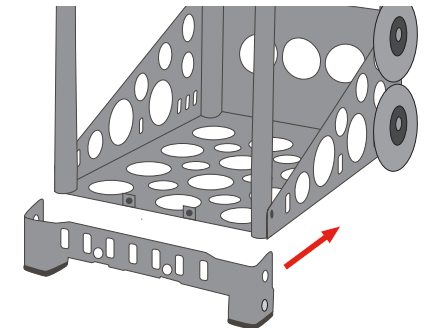

Fit the new front wrapper to the frame.

(Instructions continue on other side)