

# *PianoDisc*®

---

## Vertical Installation Guide

Version 3.2

Sept. 2018

©1996 by PianoDisc™ and Burgett, Inc. All Rights Reserved.  
PianoDisc and Burgett, Inc. reserve the right to change product design and specifications at any time without prior notice.

# Introduction

This installation manual will guide you through the process of fitting the PianoDisc reproducing piano system to virtually any vertical piano. Along with the knowledge and experience gained from a PianoDisc Installation Seminar, this guide should be an invaluable resource.

This document is considered confidential by PianoDisc, and is for the sole use of PianoDisc Certified Technicians. It may not be reproduced, distributed or quoted in whole or in part without the express written permission of PianoDisc.

This guide is only to be used in the installation of the PianoDisc Reproducing Piano with the SilentDrive system.

PianoDisc systems may ONLY be installed by technicians who have been certified by PianoDisc to perform such installations. If you have come into possession of this manual and/or Retrofit Kit and you are NOT a PianoDisc Certified Technician, DO NOT ATTEMPT TO PERFORM THE INSTALLATION. Installations not performed by a certified PianoDisc technician WILL NOT meet the requirements for warranty protection, and such an installation will likely void the piano manufacturer's warranty for the instrument and the player system, and may also be a violation of FCC rules.

Technicians may only be certified by attending the PianoDisc Installation Seminar at PianoDisc's Factory and World Headquarters in Sacramento, CA or by on site training evaluation and certification by one of the PianoDisc Factory Installation Technicians duly authorized to certify technicians. A candidate for PianoDisc certification should be a Registered Piano Technician and a member of the Piano Technicians Guild. A candidate who does not qualify under this rule will be evaluated on an individual basis, with an emphasis on total experience as a piano technician and possible previous experience in retrofitting pianos with other player piano mechanisms.

PianoDisc encourages PianoDisc technicians to comment on this installation manual by writing to: PianoDisc, 4111 North Freeway Boulevard, Sacramento, CA 95834, or by fax at (916) 567-1941. Please restrict telephone calls to technical questions and installation inquiries. Thank you.

Technical assistance for PianoDisc Certified Technicians is available Monday through Friday, 8AM–Noon and 1PM–5PM Pacific Time. The telephone number is: (916) 567-9999

# FCC INFORMATION

CAUTION: CHANGES OR MODIFICATIONS NOT EXPRESSLY APPROVED BY THE PARTY RESPONSIBLE FOR COMPLIANCE

**NOTE:** This system, when in operation, can develop radio frequency energy which can cause harmful interference to radio communication unless the equipment is installed and used in strict accordance with manual instructions. This equipment has been tested and found to comply with the limits for a Class B digital device, pursuant to Part 15 of the FCC

If the equipment does cause harmful interference to radio or television reception, which can be determined by turning the equipment on and off, the user is encouraged to try to correct the interference by one or more of the following measures:

Reorient or relocate the receiving antenna.

Increase the separation between the equipment and the receiver.

Connect the equipment into an outlet on a separate circuit from that of the receiver.

Consult PianoDisc, or an experienced radio/TV technician for help.

The user may find the following booklet prepared by the Federal Communications Commission helpful:

**How to Identify and Resolve Radio-TV Interference Problems.**

# Table of Contents

	<b>Page</b>
Introduction	i
FCC information	ii
Illustration List	iv
Step 1 Measure the piano	1
Step 2 Disassemble the piano	1
Step 3 Determine the solenoid rail direction	2
Step 4 Measure the key group	3
Step 5 Location of solenoid slot	5
Step 6 Cutting solenoid slot	7
Step 7 Assembly of the solenoid rails	7
Step 8 Positioning solenoid rails	12
Step 9 Keybed support	12
Step 10 Installing keybed support	13
Step 11 Installing key rest rail	14
Step 12 Installing solenoid rails	14
Step 13 Key solenoid height adjustment	15
Step 14 Installing pedal solenoid	15
Step 15 Preparing for mounting driver boards	18
Step 16 Mounting and connecting key driver boards	18
Step 17 Mounting the boards	19
Step 18 Connect the power and data cables	20
Step 19 Installing the power supply	22
Step 20 Key control bar	23
Step 21 System start up	25
Step 22 Adjusting Pedal Solenoid	25
Step 23 Final check list	26
Step 24 PianoDisc Parts ID	27

# Figures

	Page
Figure 1: Solenoid rail gauge	2
Figure 2: Upright piano bottom view	2
Figure 3: Solenoid position	3
Figure 4: Centering solenoid rail	4
Figure 5: Marking solenoid rail	5
Figure 6: Key frame cutout	5
Figure 7: Slot location	6
Figure 9: Slot breaks (action supports)	7
Figure 10: Solenoid mounting	8
Figure 10A: Mounting top key solenoids	8
Figure 10B: Mounting the bottom key solenoid	8
Figure 10C: Key solenoid support plate	8
Figure 10D: Key solenoid rubber washer	8
Figure 11: Twisting solenoid wires	9
Figure 12: Solenoid bracket mounting	10
Figure 13: Solenoid rail adjustment	11
Figure 14: Mounting keyed support angle iron	13
Figure 15: Keybed support bar location	13
Figure 16: Pedal solenoid location	15
Figure 16A: Pedal solenoid extension	16
Figure 17: Pedal solenoid	16
Figure 18: Pedal solenoid system side view	17
Figure 19: Key driver mounting board	18
Figure 20: PC board locations	19
Figure 21: Ground cable location	20
Figure 22: CPU, Prodigy – Front view	21
Figure 22A: CPU, Prodigy – Left end view	21
Figure 22B: CPU, Prodigy – right end view	21
Figure 23: Bass driver board plug location	21
Figure 24: key and pedal sole. Power cables	21
Figure 25: Power supply	22
Figure 25A: Power supply in piano	22
Figure 26: Piano with installed system	23
Figure 27: Key hold down bar – top view	24
Figure 28: Key hold down bar – Side view	24
Figure 29: Pedal solenoid in piano	25
Figure 30: Pedal solenoid – close up adjustment	26



## *Step 1 Measure the piano*

---

Before attempting to install the PianoDisc system onto a vertical piano, it is necessary to determine if the PianoDisc system will physically fit that particular piano.

- A. To determine if the solenoid rail will have the necessary room on the keybed, make a measuring device to check the piano. Any small piece of wood or Plexiglas will work. (See Fig. 1) The overall width of the solenoid rail is 3“(76mm), including the brackets.
- B. Measure the bottom side of the keybed, from the inside edge of the lower panel (kick board) towards the plate. (See Fig. 2) If you measure 3” (76mm) of keybed, the system will fit.

## *Step 2 Disassemble the piano*

---

- A. Remove the upper panels, fallboard, and lower panel or kickboard. Put the piano parts in a safe place.
- B. Check the piano regulation, especially the key leveling and lost motion in the keys.

**NOTE: Record the key height of keys 1 and 88.** Because of the slot location, the key rest rail must be moved forward which makes it necessary to know the key height before proceeding. Also it will be necessary to level keys and some minor regulation after the PianoDisc installation.

- C. Remove the piano action and put it in a safe place.

**Tip:** It is good to think about purchasing a lifting device to elevate the vertical piano during the installation process. A hydraulic motorcycle lift works well.

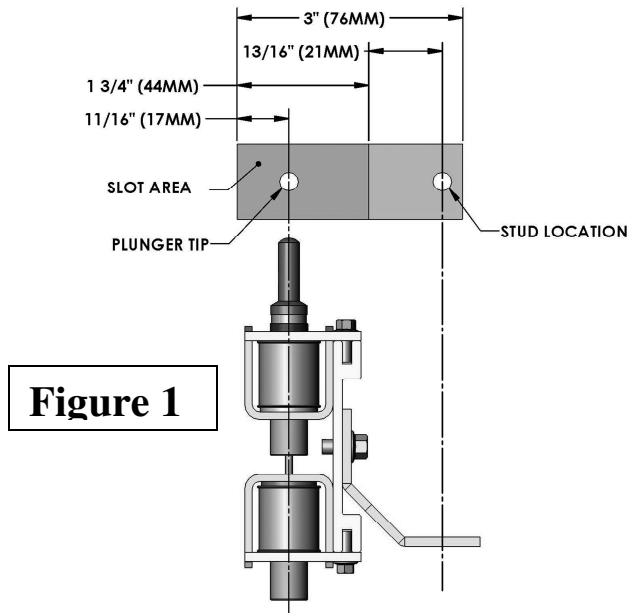

**Figure 1**

In pianos where you do not have 3" (76 mm) on the keybed, some modification could make the system fit. If you are having a problem, you can call technical support for help.

**NOTE:** By placing the mounting bracket on the recessed side of the solenoid rail the overall width of the rail assembly is 1/4" less.

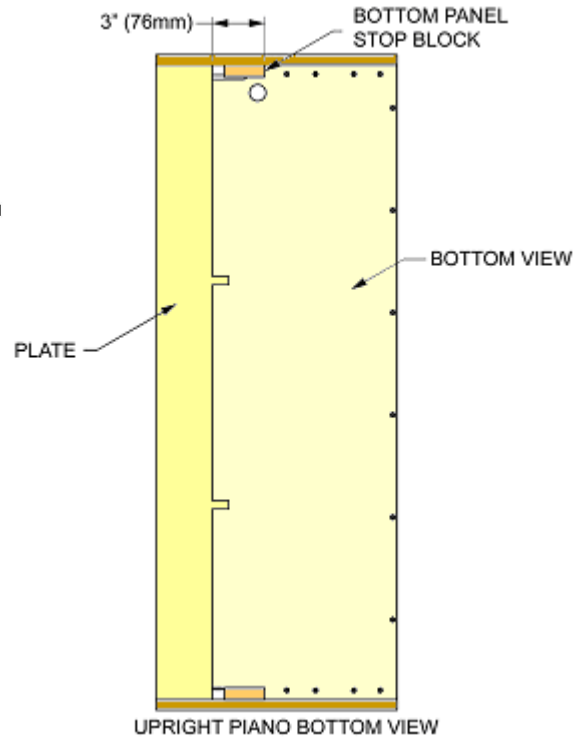

**Figure 2**

## Step 3 Determine solenoid rail direction

- A. Depending on the amount of room between the piano plate and the inside of the kickboard, it may be necessary to turn the solenoid rails around 180°, placing the mounting brackets towards the rear of the piano. Additional support of wood or angle iron may be necessary. (See Fig.3) The preferred method is to place the mounting brackets forward to place the solenoid tips at the end of the keys for the best playability.

**NOTE:** On some pianos, the middle area of the keybed is hollow. In this case just fill the hollow keybed with 2" of wood in the area of the solenoid hanger bolts. Also in most pianos the key rest felt will be in the slot location and will need to be moved forward.

- B. Once you have determined the direction of the solenoid rails, measure the keybed and check to see how close to the end of the key you can place the slot. The ideal location for the plunger tip is as far back as possible to the end of the keys.



**NOTE:** Most of the time it is necessary to trim the keyed supports (hornplate extensions) to get the solenoid slot back as far as possible. (See Fig. 3) If the keyed support is in the break area, it is advisable not to cut them.

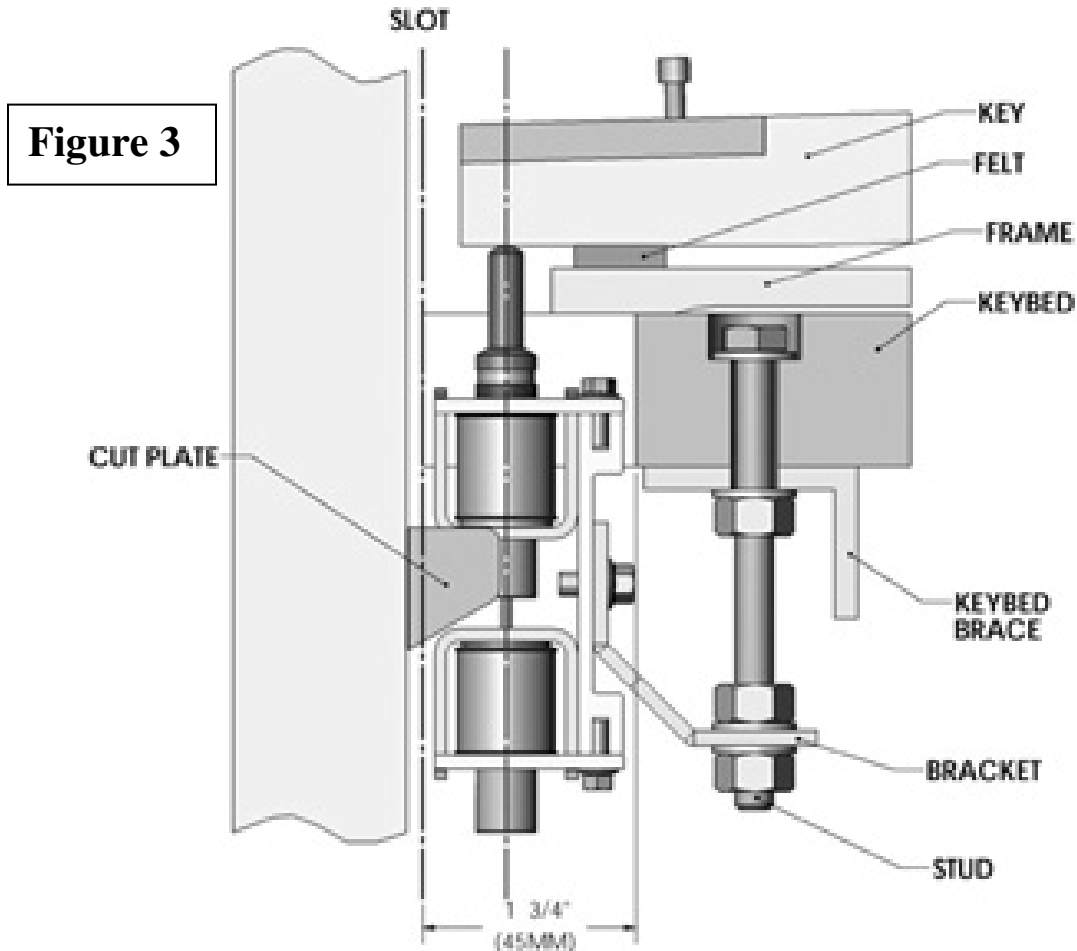

## *Step 4* Measure the key groups

- A. Establish the key groups.** The fronts of the keys are evenly spaced in one continuous line: left to right, numbered 1 through 88. The stack is typically divided into four groups. The group at the left, the bass, always has the largest hammers. This is Group 1. The mid-range group in the center of the keyboard is Group 2. Moving to the right is the low treble area, Group 3. Group 4 is the high treble area at the right end of the keyboard with the smallest hammers. The small open spaces between these groups are called “breaks”.
- B. Place and mark rail blanks.** If there are action brackets at the breaks, it will be necessary to preserve as much wood as possible for support, especially at the tenor/treble break. So it is best to use a long stem (white wire) solenoid on both

sides of the tenor/treble break.

**NOTE:** This method of placing two long stem solenoids at the tenor/treble break will require an extra long stem key solenoid. **Only use this method if there is an issue with the action bracket clearance.** The normal method is to start with a short stem solenoid at key one.

- A. Place a rail blank across the treble section at the capstan location, centering two bracket locations for the best support. (See Fig.4)

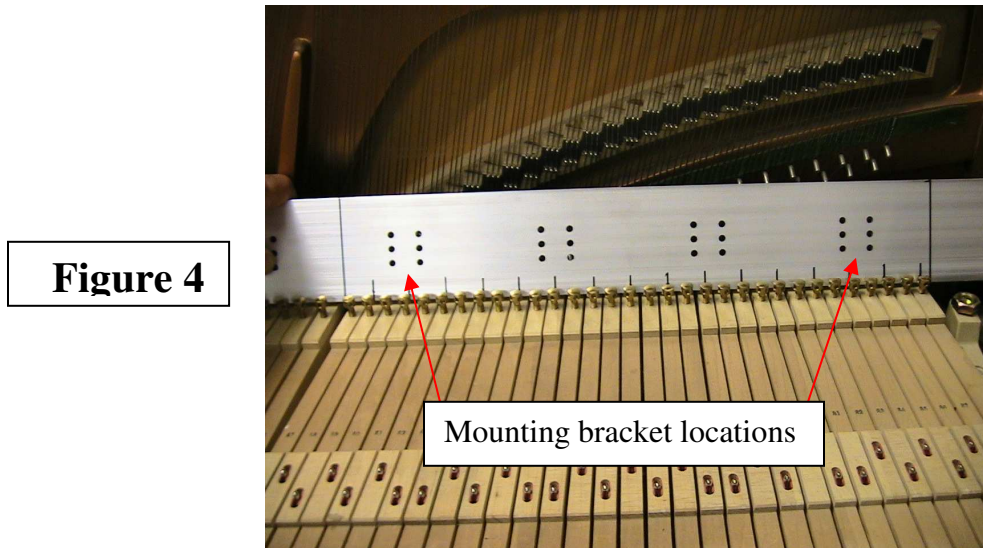

- B. Now, put a mark on the rail indicating the beginning and end of that section. For instance, if key #55 is the first key, place a mark on the rail at the outside edge of key #55 and also the outside edge of key #88. (See Fig.5 Next page)
- C. With rail blank still centered across the keys, skip key #55 and place a mark on rail centered about key #56 indicating the short stem (Black wire) solenoid locations. Skip key #57, place mark on the rail at key #58, etc. (See fig. 5)
- D. Place a rail blank across the tenor section at the capstan location, centering bracket locations for the best support and start with a long stem (white wire) solenoid for the key #54.
- E. Place a mark on the rail at the center of key #54, skip key #53, mark key# 52, etc. If the tenor section is an even number of keys, then you will end up with a short stem (black wire) solenoid at the bass/tenor break. This is not a problem usually since there is more room at this break.
- F. Place the last rail at the bass section and repeat the same procedure as the tenor section.

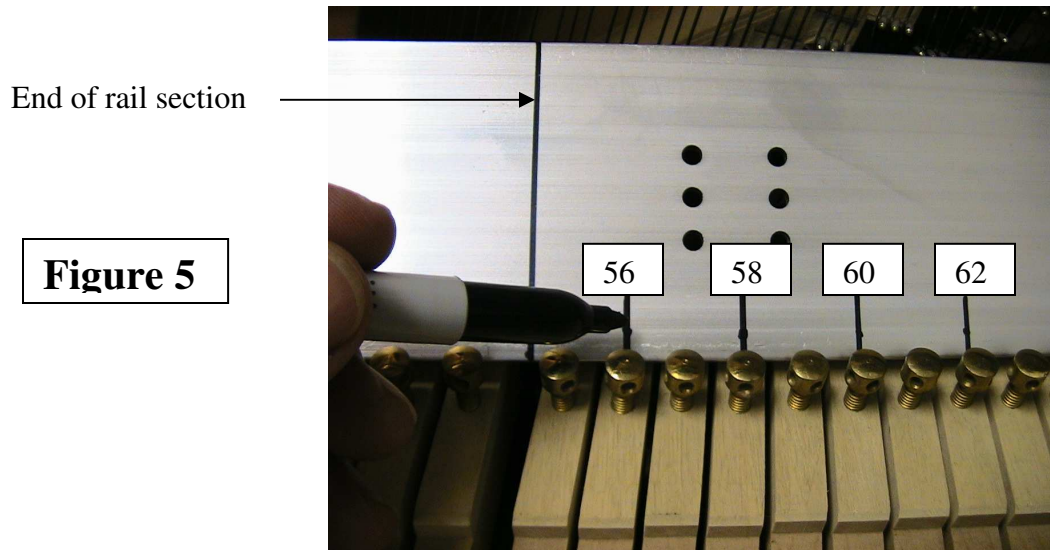
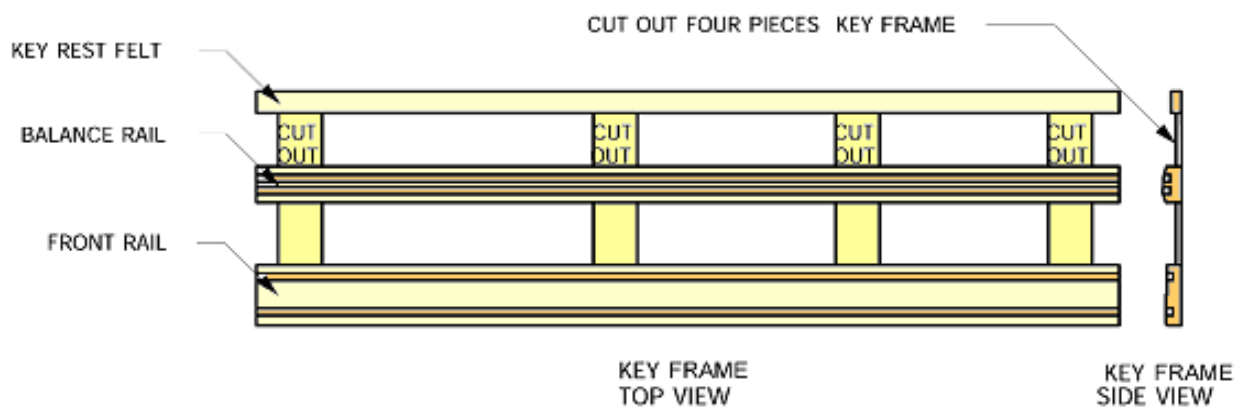

**Figure 5**

## Step 5 Location of solenoid slot

- A. If the key frame has connecting pieces of wood between the balance rail and the key rest felt, use a dovetail saw to cut the pieces without removing the key frame. (See Fig. 6) Now remove the key rest rail from the keyedbed being careful to keep track of the shim located under the rest rail.

**Figure 6.**



- B.** Looking at the bottom side of the keybed, figure how close the back edge of the solenoid slot can be to the plate including cutting off the plate supports to the keybed. This will be the back of the solenoid slot. In most pianos the back of the keybed will be cut off. (See fig. 7) (The object is to have the solenoid plunger tip as far back as possible.)

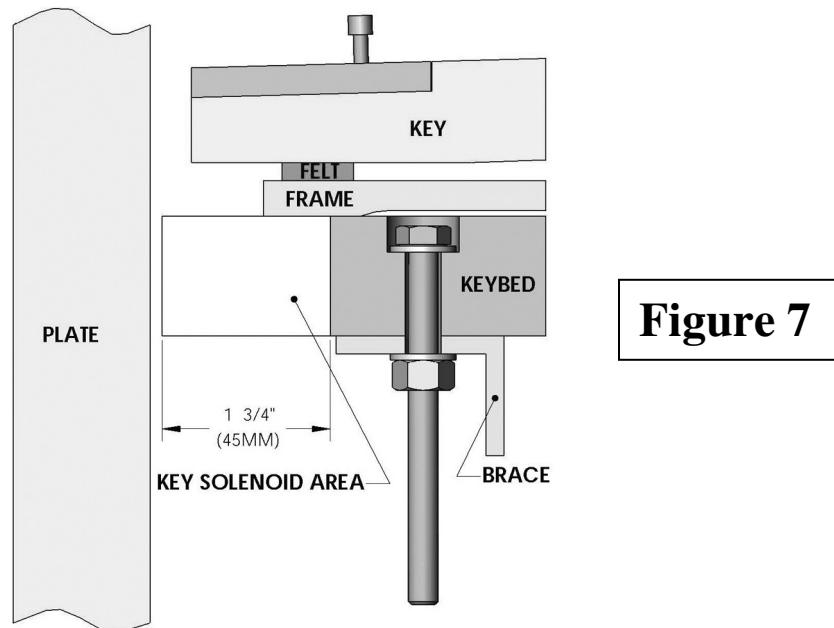

- C.** Now measure forward  $1 \frac{3}{4}$ " (45mm) to establish the front of the slot. (See Fig. 7) The back of the slot is generally close to the plate as seen in fig. 7.
- D.** Now place the "end of section" keys on the key frame to establish the end cut of each of the three sections. This is assuming the piano has action brackets at the breaks. If the piano does not have action brackets at the breaks, a continuous slot can be cut.
- E.** Measure  $\frac{3}{8}$ " (10mm) from the edge of keys 1 and 88 for solenoid clearance. This will allow room for the body of the key solenoid in the end of the slot.
- F.** At the tenor/treble break we want to preserve as much wood as possible as discussed in Step 4. (See Fig. 9) So, if a long stemmed (white wire) solenoid was planned for at the tenor/treble break, you will want to modify the support tab to conserve the amount of wood removed at the break. (See fig. 10c) Do the same for the other end keys that have long stem solenoids.

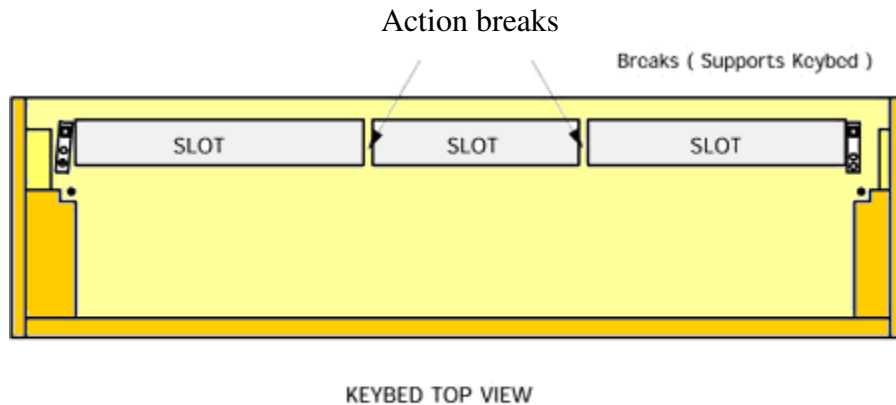

**Figure 9.**

## Step 6 Cutting the solenoid slot

**NOTE:** On some pianos, the keybed is removable, which makes cutting the slot and the plate/keybed supports easier. I prefer not removing the keybed but just using the jigsaw to cut the keybed slot. Also I use a piano tilter to put the piano on it's back to cut the plate supports with a powered jigsaw.

- A. With a 3/8" (10mm) drill bit, drill all the corners of each section, as marked in step 5. Now, cut out the sections between the holes just drilled with a heavy duty jig saw (Bosch, model #1581VS is recommended). A keyhole saw may be useful at the ends of the slot for the close clearance. Use a double cut file or 100 grit sand paper (with sanding block) to clean up cut.
- B. Vacuum or blow out the piano with compressed air and replace the keybed if removed for cutting. Also, replace the key frame to its' original position if removed.

**NOTE:** A portable powered bandsaw cuts the plate horns quickly and easily.

## Step 7 Assembly of the solenoid rails

- A. Mounting key solenoids to rails. Starting with the bass key solenoid section, clamp the bass rail to a workbench with the recessed side down. A 2"x2" (50mm x 50mm) block of wood can be used to elevate the rail. (See fig. 10)

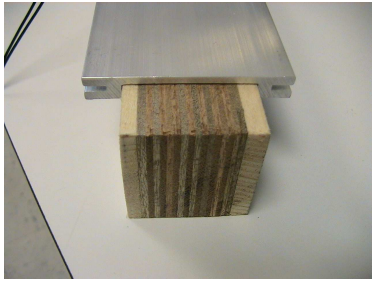

**Figure 10**

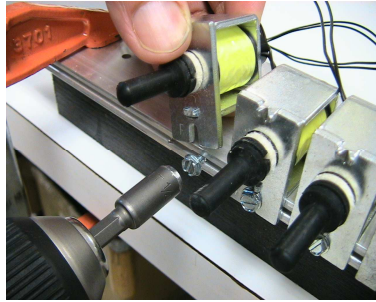

**Figure 10A**

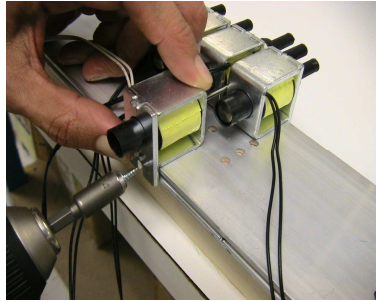

**Figure 10B**

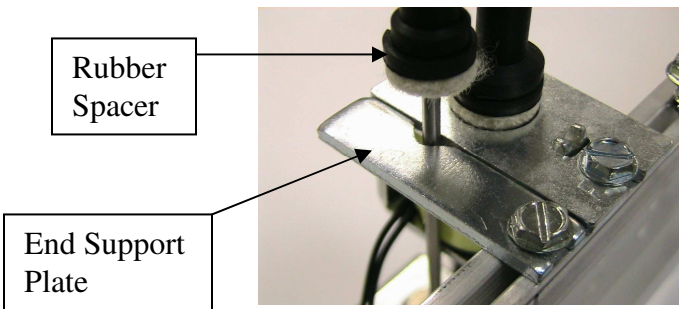

**Figure 10C**

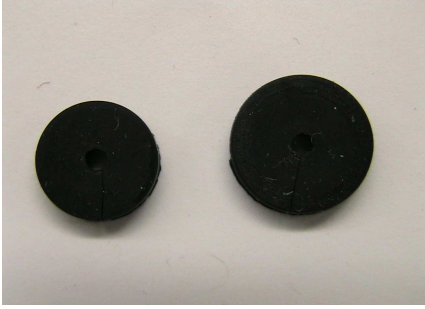

**Figure 10D**

- B.** Place a 6x32x3/8" screw on each line marked for the top row (short stem solenoid). Place the screw half way into the rail at each location marked on the rail.
- C.** Next, place a short stem solenoid (back wire) on the flat side of the solenoid rail at the first screw. (See fig. 10a)
- D.** While holding the solenoid firmly against the rail, secure the solenoid by tightening the screw. Continue with the next solenoid until all top solenoids are installed on this rail.
- E.** Remove clamps from rail plate and rotate rail 180 degrees. Clamp rail back to the bench.
- F.** Now place a long stem solenoid on the solenoid rail spacing the stem between the top row solenoids. Hold the solenoid firmly and place a (10mm) screw in solenoid mounting slot. Install the appropriate number of long stem solenoids on the solenoid rail. (See figure 10b)

- H. Locate the end support plates in the kit and place them on the end of the rail sections where there is a long stem (white wire) solenoid for support.

**NOTE:** It may be necessary to grind a notch into the end support plate to preserve as much wood as possible at the breaks. (See figure 10c)

- I. Twist one black and one white wire together using a wire hook with a powered drill. This not only makes it easier to work with the wires, but also makes a cleaner installation. (See Fig. 11)

**Figure 11**



**NOTE:** Be careful not to over twist the key solenoid wires causing damage to the wire or connector.

- J. Cut the rails to the proper lengths. To keep any aluminum shavings from falling into the solenoid cylinders, pull the plungers up until the plungers in the solenoid protrude from the tops of the cylinders by about 1/16". Use masking tape to hold the plungers in these positions. Carefully trim off the excess length of aluminum rail, making sure the solenoids are not damaged or shifted in the trimming process.
- K. Thoroughly clean the solenoid rail assembly with compressed air after smoothing the edges with a file.
- L. Repeat the above mentioned steps for the tenor and treble sections.
- M. Locate the baggie of rubber spacers in the kit. Notice there are two sizes of rubber spacers. The larger diameter spacers are for the top row solenoids and the smaller diameter spacers are for the bottom row solenoids. Place the rubber spacers between the felt washer and the rubber tip. (See figure 10c & 10d)

**NOTE:** There is a cut in the washer for ease of installation.

**NOTE:** The purpose of the washer is to shorten the stroke of the key solenoid to accommodate the shorter travel distance of most vertical pianos. If you find that the travel distance of the key (at the solenoid contact area) is .340" (8.6mm) or more, then the rubber spacer is not necessary.

- N.** Attaching the bracket to the rail requires (2) #10 x 1/2" hex-headed screws per bracket, which are provided in the kit. Each bracket location has (3) sets of mounting holes. **Always use the middle set of holes.** The mounting bracket should be positioned so that it extends down from the slot. The bracket should be positioned so that the mounting screws are approximately in the middle of the slot. This leaves room for a small final adjustment. Mount (2) brackets on each rail. (See Fig. 12)

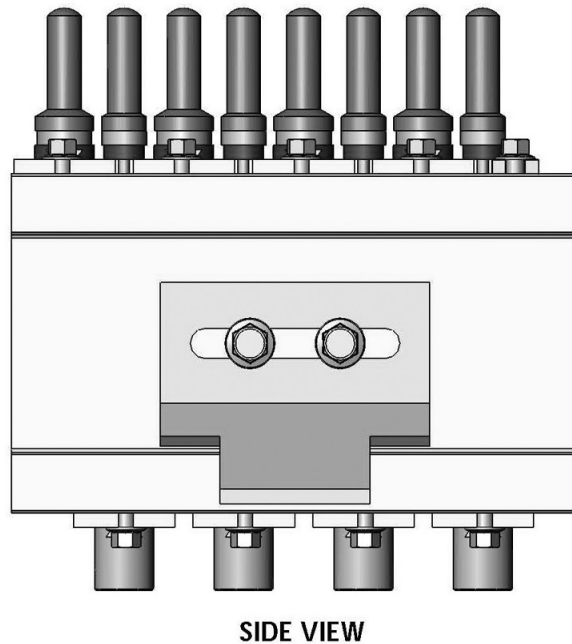
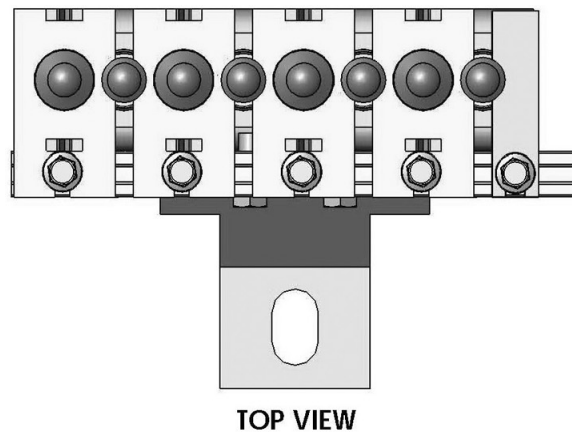

**Figure 12**



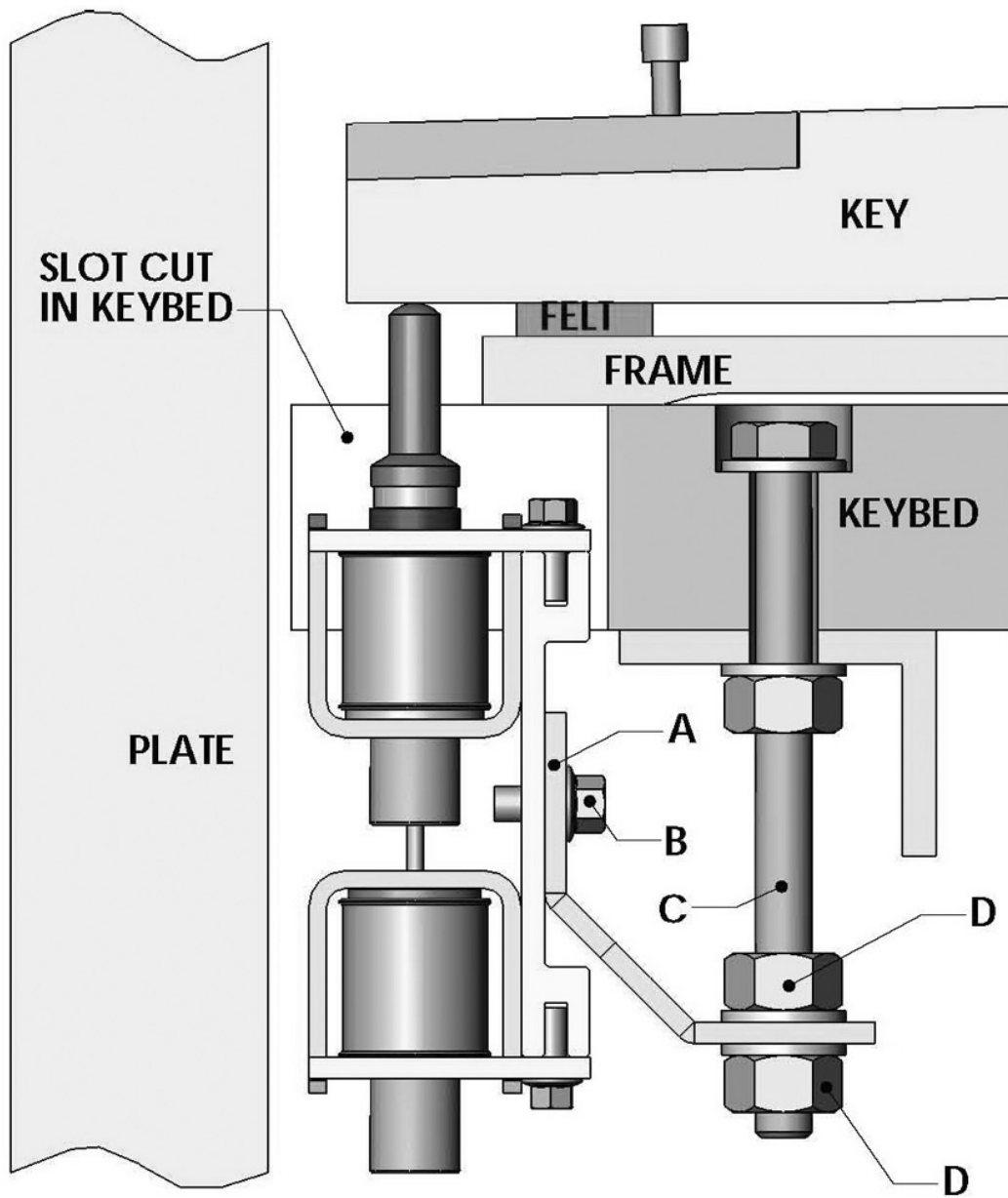

- A - MOUNTING BRACKET
- B - #10 X 1/2 " HEX HEAD SELF-THREADING SCREW
- C - HANGER BOLT
- D - 5/16-18 JAM NUT

Figure 13

## *Step 8* Positioning solenoid rails

---

- A. Place the end section keys on the keyframe.
- B. Place the (2) stud locators (blue blocks, supplied by PianoDisc) onto the bass section hanger brackets.
- C. Place the bass solenoid section into the piano centering with the end keys and tap the pins with a hammer to locate the studs. Now do this with the other two sections.

**NOTE:** If the studs are forward of the slot, it is important to place the keyed support (Angle Iron) at the stud location. In this case, a 3 1/2" (89mm) fully threaded bolt (supplied in the kit) will be used to attach the keyed support to the keyed. These bolts will also serve as the hanger studs for the key solenoid rails.

- D. Drill the (6) hanger bolt locations with an 11/32" (9mm) drill bit. Use a drill guide to maintain a 90 degree hole. Use a 3/4" Forstner bit to counter sink the head of the bolts into the top of the keyed.
- E. In the event the mounting brackets must be placed toward the plate, the hanger studs will normally be used. (Available from PianoDisc) It is important to have 1 1/2" (38mm) thickness of keyed for mounting the hanger stud. For example, if there is only a 3/4" thick keyed, an additional 3/4" of wood must be glued to the keyed, at the stud location, to proper support of the solenoid rails.

**NOTE:** Very few times do you need to mount the solenoid rail behind the slot.

## *Step 9* Keybed support

---

- A. The support of the keybed is very important. Added support is necessary because the keybed plate supports have been cut away for the key solenoid slot.  
The best material to reinforce with is 1/8" x 1 1/2" (3mm x 38mm) angle iron. It provides more clearance and strength than the 1" (25mm) square tube used in the past.
- B. Cut a piece of 1 1/2" (38mm) angle iron the full length of the solenoid slot. Temporarily clamp the angle iron under the keybed centered over the hanger bolt holes. (Flush with the front edge of the slot) (See Fig.

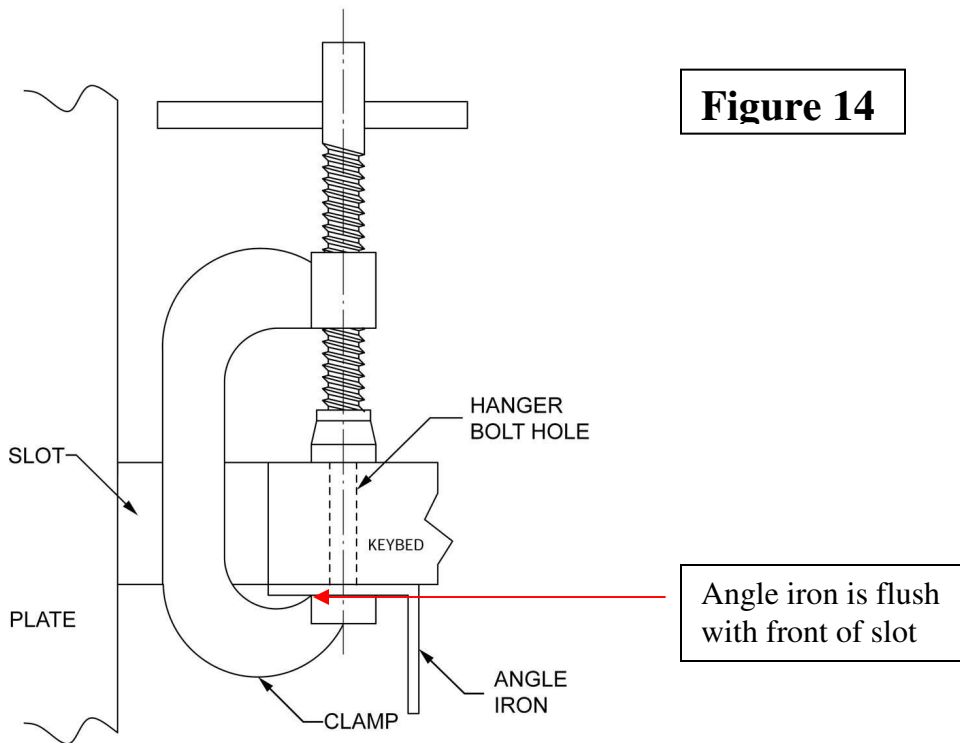
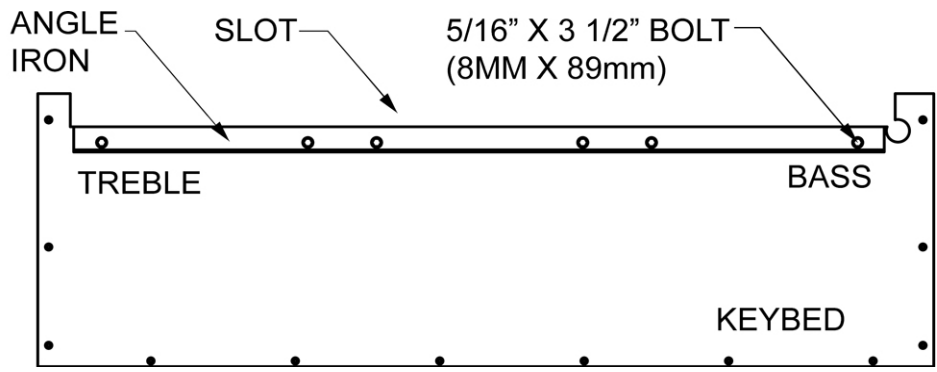

**Figure 14**

- C. Use a pencil to mark the location on the angle iron through the keybed holes just drilled.
- D. Remove the angle iron from the piano and with the drill press, drill the 6 - 11/32" (9mm) holes. Now file any sharp edges or burrs off and paint black.

## Step 10 Installing keybed support

- A. Place the (6) 5/16 x 3 1/2" (8mm x 89mm) bolts in the keybed and bolt the angle iron in place with lock washers. (See Fig. 15)



**Figure 15**

- B.** As in the case of the solenoid rail brackets in the rear, there must be the 1 1/2" (38mm) angle iron support on the keybed in front of the slot. Use the appropriate length lag bolt to attach the angle iron.

## *Step 11* Installing key rest rail

---

- A.** Position the rest rails on the keybed close to the solenoid plunger tip while still maintaining a 1/4" (6mm) clearance. (See figure 13 on page 12) With the end keys of each section in place, space the rails side to side.
- B.** Holding keys #1 and 88 in the rest position, measure the key height and determine if any shimming up of the rest rail is necessary. Key height measurement was taken in Step 2.
- C.** Secure the rest rails to the keybed with the original screws.

**NOTE:** This is a good time to level the keys. Most vertical pianos need key leveling because of the key rest rail re-location.

## *Step 12* Installing solenoid rails

---

- A.** Place the end keys of each section onto the keyframe.
- B.** Put a nut on each hanger bolt about halfway on the threads.
- C.** Place all (3) solenoid rails on the piano with another nut on each bolt and tighten temporarily. Now see if they are equally spaced between the end keys of each section.
- D.** If some adjustment is necessary, remove the section, mark the location of both brackets with a pencil, loosen the bracket screws and relocate the brackets side to side.. Place the solenoid rail back into the slot location and recheck.

Now is the time to install the rest of the keys and observing the plunger tip location on the key. The plunger tip should be close to the center of each key.

## Step 13 Key solenoid height adjustment

---

**NOTE:** It is important to level the keys before making the final key solenoid rail adjustment.

**NOTE:** The current spring less key solenoid should have no gap (or very little) between the plunger tip and the bottom of the key.

- A. Adjust the key solenoid rails up to the bottom of the keys and tighten the adjustment nuts.
- B. Place the rest of the keys on the key frame observing the plunger tip to key side to side alignment.
- C. Put the action stack into the piano.

## Step 14 Installing pedal solenoid

---

- A. Now is the time to install the pedal solenoid. First of all, you must support the horizontal lever directly below the pedal solenoid or as close as possible. Measure the distance from the bottom board to the bottom of the horizontal lever.
- B. Use a piece of wood 2"x2" (50mm x50mm) x the length just measured. (The piece of wood from the solenoid slot works well) Glue this piece of wood under the horizontal bar with a piece of 1/4" woven felt (or thicker) between the support block and the horizontal bar.

**NOTE:** Always place the pedal solenoid as low as possible to keep the center of gravity to the best advantage. (See Fig. 16)

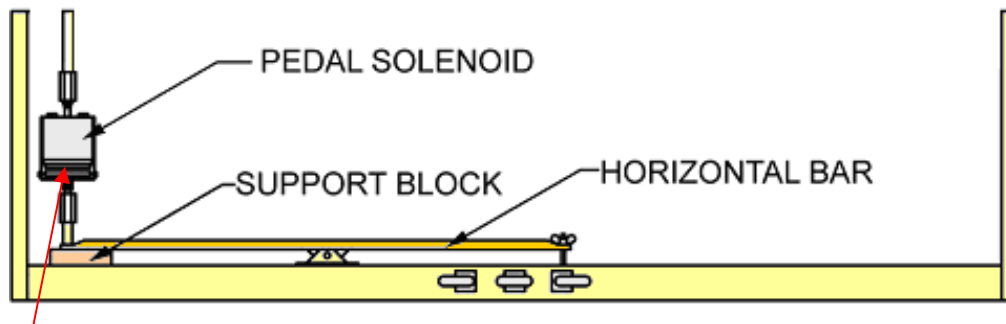

**Rest Pad**

**Figure 16**

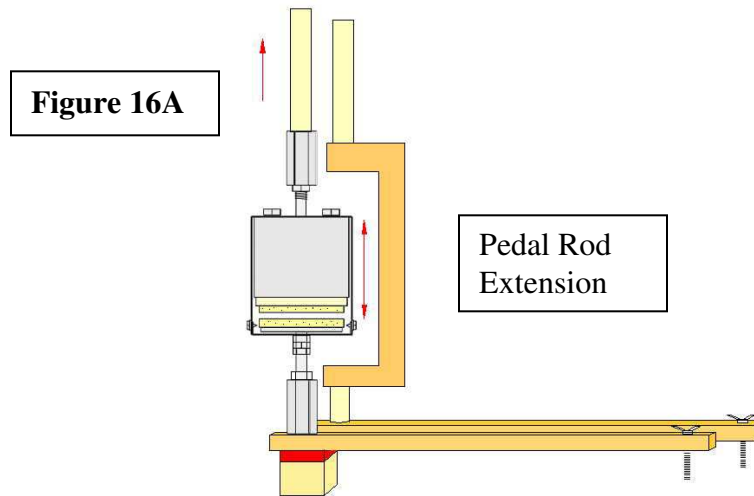

**NOTE:** In the event that the trapwork dowels are too close together to place a pedal solenoid, an extension can be made out of  $\frac{1}{2}$ " plywood for the offending dowel. (See figure 16A above)

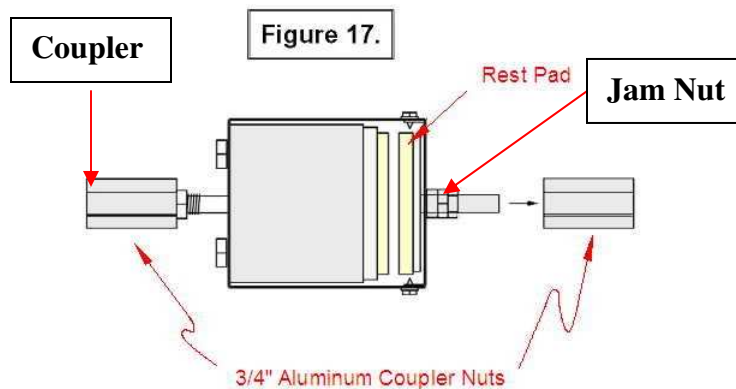

**C.** Loosen the 14 mm jam nut that secures the rest pad on the pedal solenoid and center the rest pad in the area between the plunger and the sheet metal base. (See figure 17) This will be very close to the final adjustment.

**NOTE: The second jam nut secures the aluminum coupler.**

**D.** Remove the aluminum coupler from the rest pad side of the pedal solenoid.

**E.** Locate the short  $\frac{1}{2}$ " (13mm) dowel supplied in the kit. (It has a pin on one end.) If the solenoid can be placed on the lever without interference with the plate, cut the  $\frac{1}{2}$ " wood dowel  $\frac{3}{4}$ " (19mm) long, from the pin end, to fill the void of the  $\frac{3}{4}$ " aluminum nut. Make sure to fill the aluminum coupler nut on the "rest pad" side. Use a hammer to tap the  $\frac{1}{2}$ " (13mm) dowel into the aluminum coupler nut. (See Fig. 16 & 17)

**F.** (Center the other (top)  $\frac{3}{4}$ " (19mm) aluminum coupler nut on the threaded rod for future adjustment.

- G.** Place the pedal solenoid on the sustain horizontal bar with the rest pad in the down position and measure from the top of the aluminum coupler nut to the sustain lever (on the action). Now add  $\frac{3}{4}$ " (19mm) to this length for the recess into aluminum coupler nut.
- H.** Locate the 24"(2m) wooden dowel in the kit. Measure the wood dowel from the "pin end" and cut to the length just measured in step G. Remove the top aluminum coupler nut and use a hammer to tap the  $\frac{1}{2}$ " (13mm) wood dowel into the aluminum coupler nut. Reconnect the aluminum coupler nut back on the pedal solenoid.
- I.** Place the pedal solenoid assembly on the piano. Start with placing the long wood dowel pin into the sustain lever (piano action) and then the pedal solenoid on the sustain horizontal bar. See Figure 18.

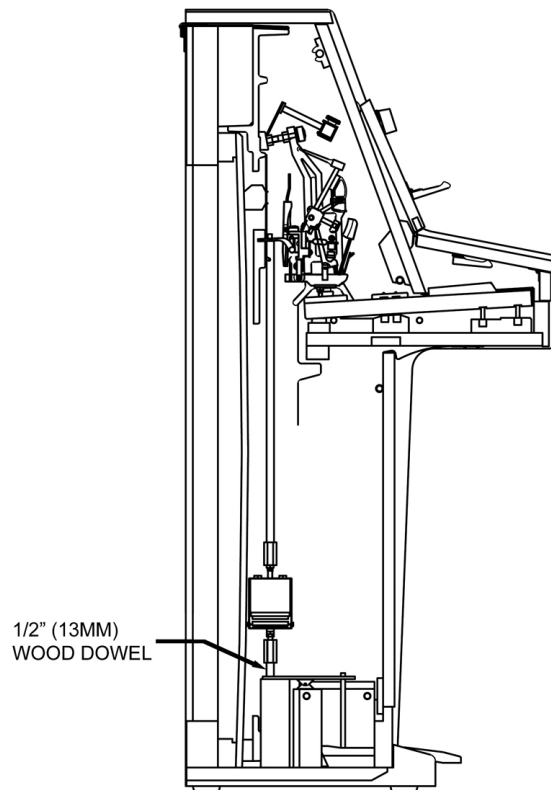
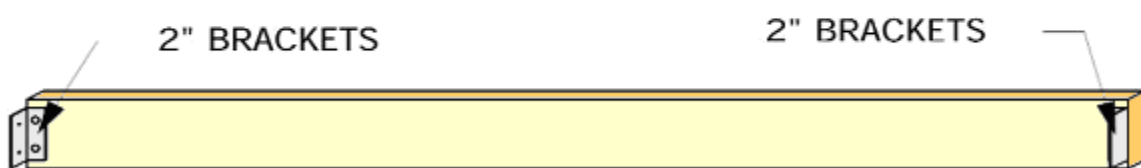

**Figure 18**

## Step 15 Preparing for mounting driver boards

- A. A mounting board must be placed below the key solenoid rails to mount the driver boards.
- B. Measure the inside length of the piano cabinet.
- C. Use a board 1" thick x 3" wide (25mm x 76mm) and cut to the length taken in step B.
- D. Locate the (2) 2" (50mm) "L" brackets and mounting screws in the kit. Attach the "L" brackets to each end of the board. (See Fig. 19)

Figure 19.



## Step 16 Mounting & connecting key driver boards

**Connect the solenoids to the key driver boards.** The key driver boards are identical so it does not matter which position they are in. There are 30 key solenoid plug connections on each of the 3 key driver boards with a total of 90 possible connections. If all 88 piano keys are equipped with a key solenoid, then two plug connections (4 pins) out of the 90 connections will not be used. The two plug connections that are never used are at the end of the treble board.

- A. Start with attaching the key # 1 solenoid connector (lowest bass note) to pin 1 of the key driver board that is assigned to the bass section.
- B. Continue moving to the right plugging each key solenoid until all 88 key solenoids connections have been completed. Do not leave any empty spaces on the bass or tenor driver boards.

**NOTE:** In the event of space limitations within the piano cabinet, it may not be possible to accommodate all 88 key solenoids. It will be necessary to omit the first two or three plug connections on the key driver board. For example, if key # 3 is the first key solenoid, then leave the first 2 plug connections empty and start with the 3<sup>rd</sup> plug position.



## Step 17 Mounting Driver boards and CPU

---

- A.** Now that the key solenoids are plugged into the key driver boards, it is time to attach the driver boards. The key driver boards should be positioned on the mounting board to allow all key solenoid wires to be stress free.
- B.** Locate the driver board/CPU mounting screws in the kit.
- C.** Secure the (3) driver boards and the C.P.U. interface to the mounting board. Place the ground straps under each driver board, CPU and power supply. (See Fig.20 & 21 on the next page)

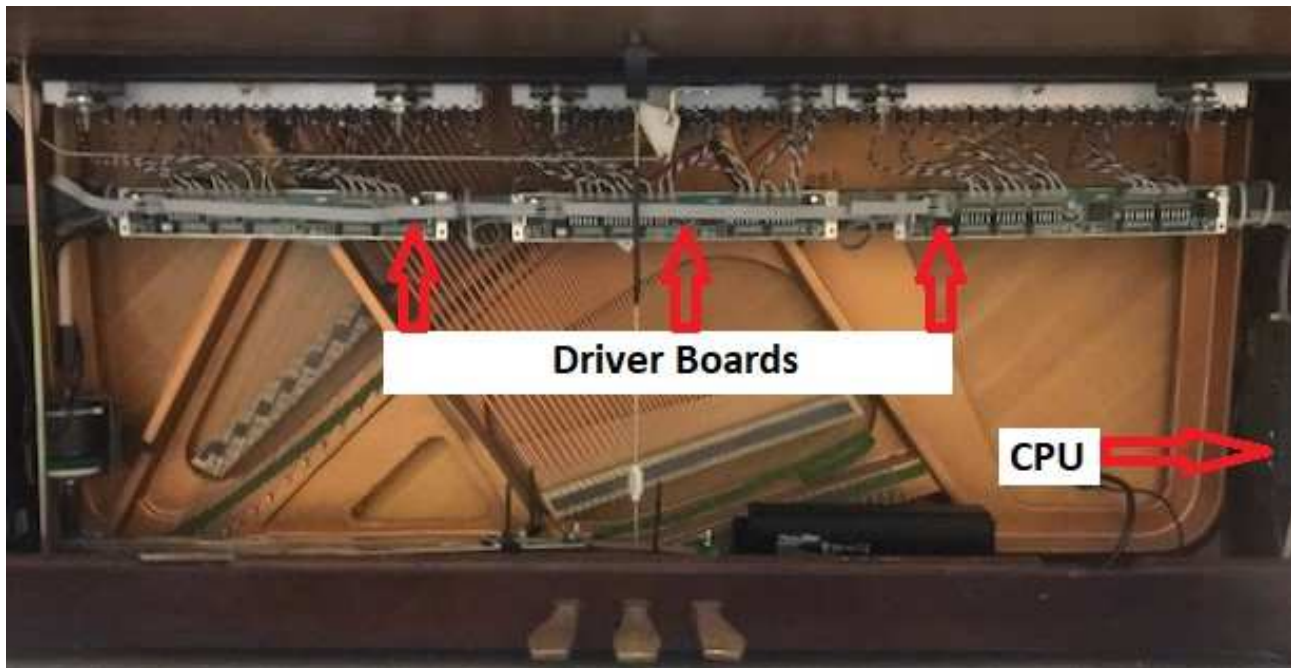
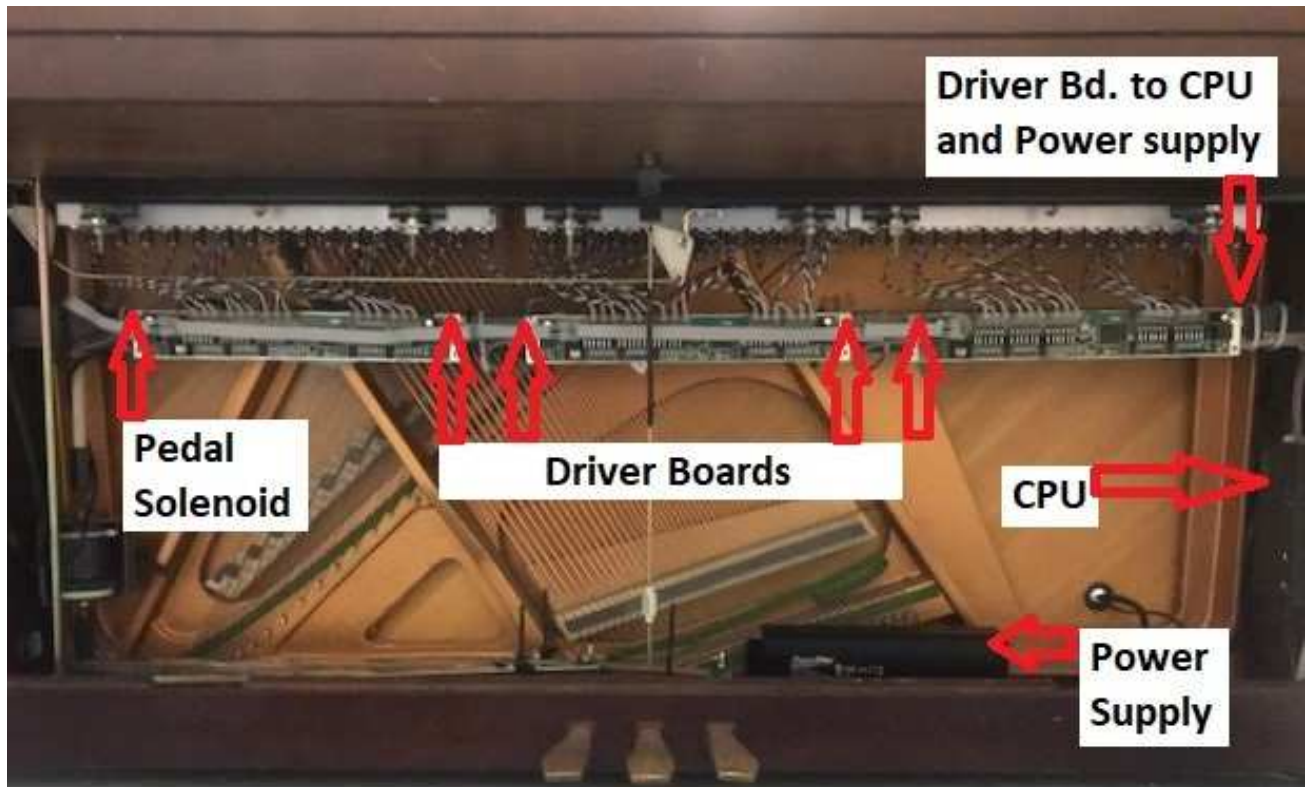

Figure 20

□



**Ground Strap Connections**

**Figure 21**

## ***Step 18* Connect the power and data cables**

- A.** Connect the Data/10 VDC cable: Locate the black flat RJ-45 data cable in the kit. Plug in one end into the CPU labeled “Driver” (See Figure 22B) and the other end to the bass driver board. (See figure 23)
- B.** Connect remaining data cables: Locate two 8” gray data cables (RJ-45) in the kit, connect them into the second and third driver boards.
- C.** Connecting the solenoid power cable: Locate the gray 4-wire power cable in the kit. (See figure 24) This cable delivers the 43 VDC to power key solenoids and sustain pedal solenoid.  
**NOTE:** This cable has 3 evenly space plugs that connect into each key driver board and then connects to an adapter cable which plugs into the power supply. (See figure 24)
- D.** Connecting the pedal power cable: Connect the pedal solenoid 2-pin plug into the bass driver board. (See figure 23)



**Figure 22 - Prodigy CPU**



**Figure 22A - Left Side**



**Figure 22B – Right side**

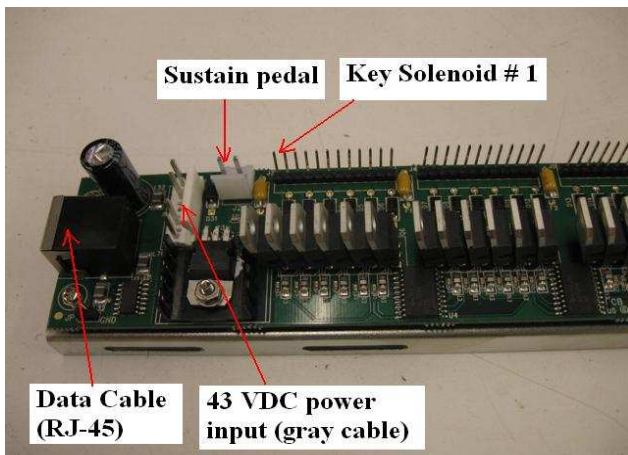

**Figure 23**

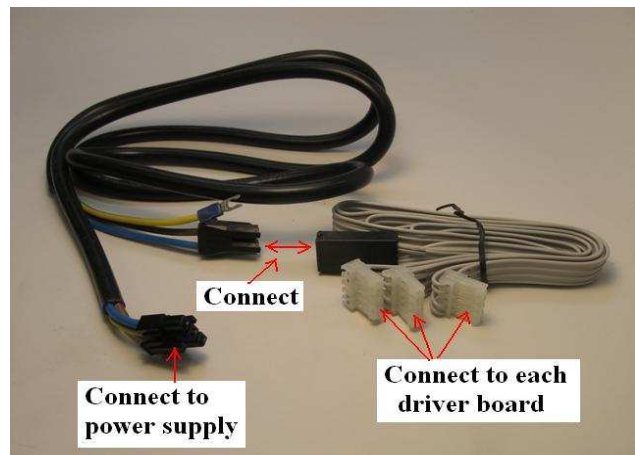

**Figure 24**

## Step 19 Installing the power supply

---

- A. In most cases, there will be adequate room in the piano cabinet (lower right) to secure the power supply to the bottom board. But some pianos may have trap work in the way or inadequate room. The power supply in figure 25 is the current model and can mount flat or vertically for tight locations. The power supply has built-in mounting tangs and also comes with 2 – “L” brackets to mount vertically. (See fig. 25A) Locate the mounting screws supplied in the kit and secure the power supply to the bottom board. Make sure to place the ground strap under the power supply.



Figure 25

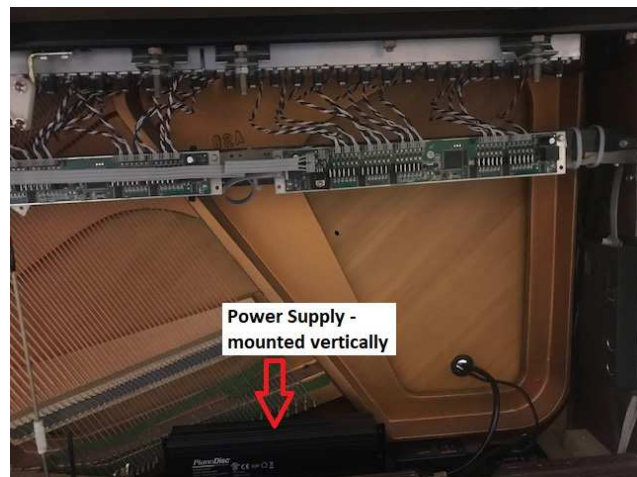

Figure 25A

- B. Neatly route and secure all cables. (See figure 26 next page)

**NOTE: Never tie together A/C cables with data or speaker cables. The high voltage can bleed into other cables causing noise or problems.**



**Figure 26**

## *Step 20* Key control bar

---

If the key solenoids are positioned forward of the key capstans, it is possible the keys may be lifted off their balance point when the key solenoid is activated. This will cause the piano to play poorly. If this is the case, it will be necessary to place a hold down bar across the keys at the balance point. Normally the key control bar is not needed.

- A.** Measure from key #1 to #88 at the balance rail. Add 3/4" past each end key (1 and 88) to accommodate a hold down screw. (See Fig. 27)
- B.** Use 1/2" channel aluminum and cut to the length measured in step A. This channel aluminum and hardware are not supplied in the kit.

**NOTE:** Hanger screws are used for the support for the hold down rail, they are 3" (76mm) in length half of the hanger screw is an 8-24 thread and the other half is a wood thread. (See figure 28)

- C.** Place the bar across the keys between the balance pins (sharps and naturals).
- D.** Place a mark at the (4) locations for the hold-down screws. One at each end and one at each break. (See Fig. 27)

- E. Use a 7/32" (5.6mm) drill bit and drill the (4) locations just marked on the bar. File off any burrs.

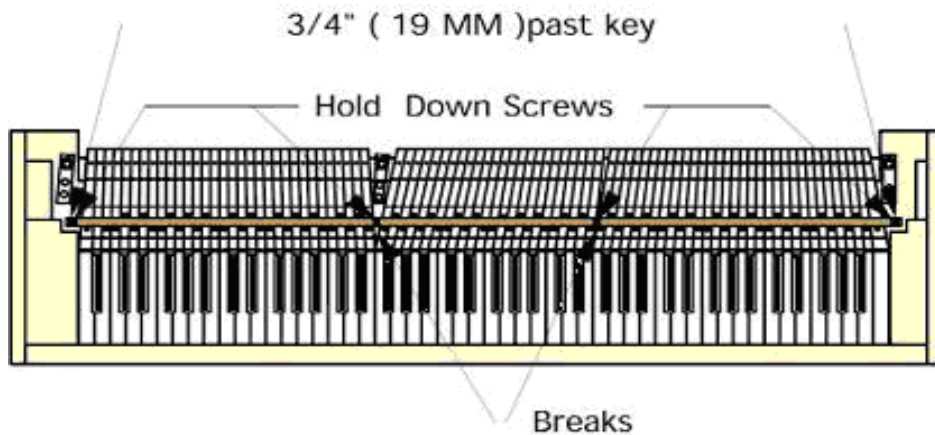

**Figure 27**

- F. Place the bar on the keys, look down through the holes and mark the location on the piano.
- G. Drill (4) holes just marked on the piano with a 5/32" (4mm) drill bit, 1" (25mm) deep. It may be necessary to build up the end locations with wood.
- H. Use nuts and washers to retain the hold down bar. (See Figure 28)
- I. Use a piece of 1/4" (6mm) thick felt (1/2" (13mm) wide by length of bar) to attach to the bottom side of the bar.
- J. Adjust the key control bar so it does not restrict the sharp note when depress.

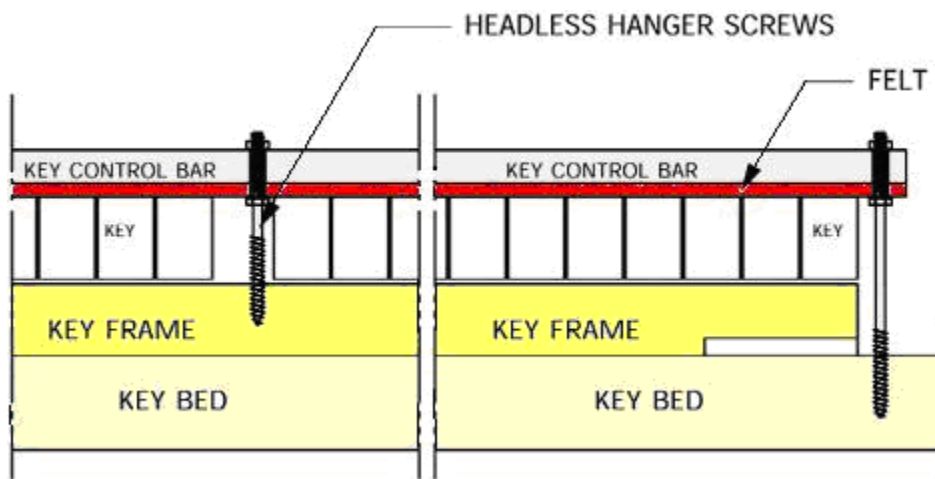

**Figure 28**

## Step 21 System start up

---

- A. Check all cable connections
- B. Plug the system into a 120 volt outlet.
- C. Turn the power strip.
- D. Press the test button located on the C.P.U. and the system will start playing the Key solenoids and pedal solenoid. Notice the lights flashing prior to the solenoids playing, these lights signify the CPU software version. The MIDI light will flash 5 times (representing “15”) and the sustain light will flash 1 time which represents 15.”1”. (Software version – 15.1)
- E. The reset button is used as a soft re-boot and will reset system operation.

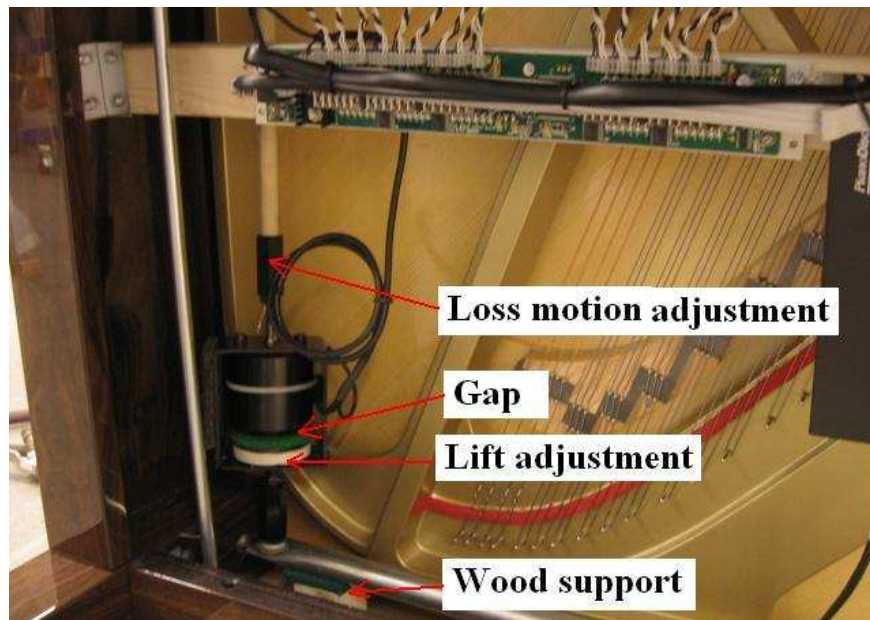

Figure 29

---

## Step 22 Adjusting Pedal Solenoid

---

- A. Adjust the pedal solenoid damper lift so the wedge dampers just clear the strings.
  - Loosen the jam nut on the bottom of the solenoid so that the large washer/white felt will rotate.
  - Adjust the washer/white felt by rotating it until there is an even spacing. (See figure 30) This gap is the amount of travel for the solenoid. It will be very close to the amount of lift necessary.

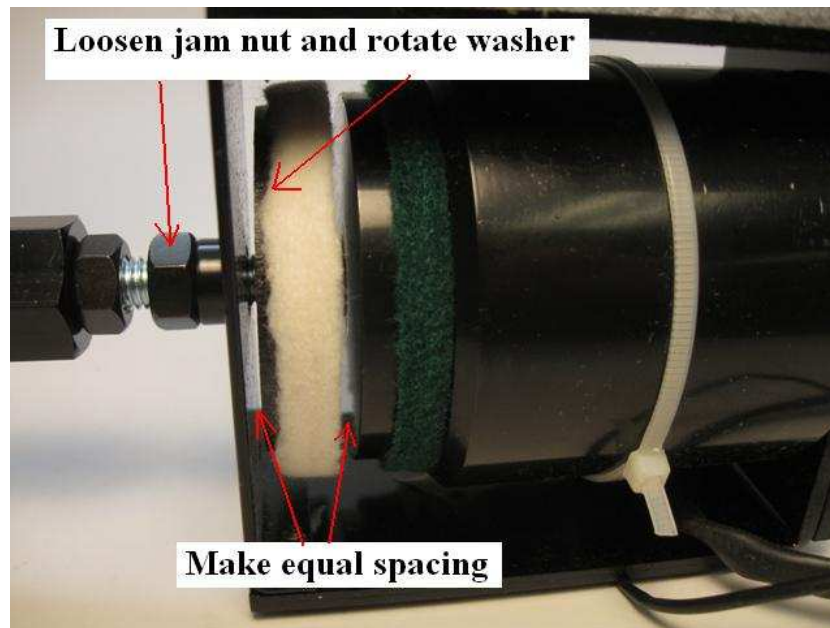

**Figure 30**

- B.** Now remove the loss motion: Rotate the top  $\frac{3}{4}$ " (19mm) coupler to remove most of the loss motion.
- C.** Play the damper test to see if the damper lift is correct, if not re-adjust. A minimal lift, wedge damper clearing string, is best.
- D.** Once the lift and loss motion is correct tighten all jam nuts.

## ***STEP 23*** - Final Check List

---

- A.** Play the system: Verify that all solenoids, keys, and pedals are functioning properly.
- B.** Neatly secure all cables and cords with the proper fasteners.
- C.** Operate the system for at least 8 hours continuously. Recheck the piano and the PianoDisc system for proper operation.
- D.** Perform set-up with the PianoDisc Calibration app from the Apple Store for the best set-up. If this is a Prodigy system then you can connect thru Bluetooth. If this is before Prodigy (June 2018) then you must have the Roland Midi Interface cable, P.N.-UM-ONE (USB to MIDI Cable) with the Apple Lightning Adapter to connect the iPad. The iPad must be iOS-8 (operating system) or newer.



# PianoDisc Parts ID

The following is a complete inventory of the parts and part numbers within the Vertical Kit.

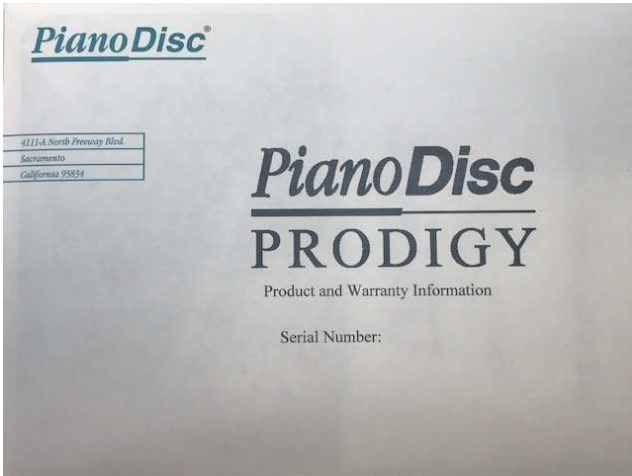

User Pack

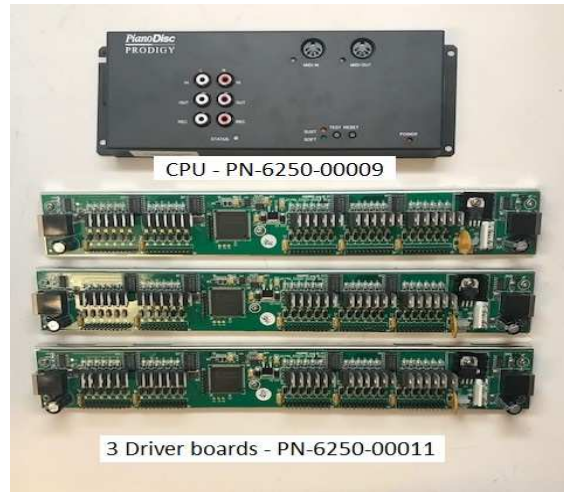

CPU - PN-6250-00009

3 Driver boards - PN-6250-00011



10 VDC  
Power  
supply

PN: 3350-00015



## PianoDisc Parts ID (cont.)



## PianoDisc Parts ID (cont.)



## PianoDisc Parts ID (cont.)



