



MANUAL



SIMRAD AP25
Autopilot

20221495F

Sw.1.3

English

Instruction Manual

This manual is intended as a reference guide for operating and correctly installing the AP25 autopilot.

Great care has been paid to simplify operation and set-up of the Simrad AP25, however, an autopilot is a complex electronic system. It is affected by sea conditions, speed of the vessel, hull shape and size.

Please take time to read this manual to get a thorough understanding of the operation and system components and their relationship to a complete AP25 autopilot system.

Other documentation material that is included in this manual is a warranty card. This must be filled out by the authorized dealer that performed the installation and mailed in to activate the warranty.

Document history

- Rev. A First edition.
- Rev. B Minor corrections in text. Table with SimNet/NMEA2000 messages included.
- Rev. C FU50 substituted by FU25. Part no. for AC40 Power PCB ass'y, page 136 corrected. Added notes in chapter 3.19. Minor corrections in text and display pictures.
- Rev. D Figures 3-6, 3-9, 3-19 and drawing/screen picture on page 39 and 50 corrected. Minor corrections in text. Updated according to autopilot SW 1.2.00
- Rev. E Virtual feedback implemented. Minor corrections to text. Applies for SW 1.2.01 and onwards.
- Rev. F Correction on page 71, 93 and 150 regarding external alarm on AC10. Use of AT10 for connection of NMEA compass when AC10 is used as autopilot computer, page 90.

Contents

1	System description	9
1.1	General	9
1.2	How to use this manual	9
1.3	System components	10
1.4	AP25 Control Unit	11
1.5	Autopilot Computer	11
1.6	RF300 Rudder Feedback unit	11
1.7	Heading Sensors	12
	RC36 Rate compass	12
	RFC35 Electronic Fluxgate Compass (optional)	12
	NMEA compass (optional)	12
	Simrad gyrocompasses	12
1.8	Optional equipment	13
	R3000X Remote Control	13
	JS10 Joystick	13
	FU25 Follow-Up Steering Lever	13
	TI25 Thruster Interface	13
	Multiple stations	14
1.9	Software record	14
2	Operation	15
2.1	Overview	15
2.2	ON/OFF - Standby mode	16
	Flashing course knob icon	17
	Alarms	17
2.3	AP25 with MSD50 Stern Drive unit	18
	Zero point setting	18
2.4	Follow-Up steering (FU)	19
2.5	Non-Follow-Up steering (NFU)	19
2.6	R3000X Remote Control (NFU)	20
2.7	JS10 Joystick (NFU)	20
2.8	Automatic Steering	21

Heading capture	21
2.9 Automatic control of steering parameters.....	22
Power boat.....	22
Sailboat.....	23
2.10 Manual Selection of HI/LO Parameters.....	23
2.11 PATTERN steering.....	24
U-turn	24
C-turn	25
Spiral-turn	26
Zigzag-turns	27
Square-turn.....	28
Lazy S-turn.....	29
Depth Contour.....	30
2.12 Dodge in AUTO.....	32
2.13 Thruster Steering (optional).....	33
2.14 Tacking in Auto mode	35
2.15 NoDrift.....	35
Dodge in NoDrift mode	36
2.16 Navigating with the AP25.....	37
Setting the waypoint arrival circle	39
2.17 Dodge in NAV	40
2.18 Selecting a different Navigation source.....	41
2.19 Wind vane steering.....	41
2.20 Tacking and gybing in Wind mode.....	43
Tack and gybe operations	44
Tack and gybe prevent	44
2.21 Wind steering and navigation	45
Operating in WIND _{NAV} mode.....	47
RACING	47
2.22 Multiple station system.....	48
2.23 Lock function	48
2.24 User Set-up Menu	50
Alternating Course Knob Icon.....	50
STANDBY Mode	50

AUTO Mode	56
NAV Mode.....	58
WIND Mode	58
2.25 Quick Setup.....	59
VMG optimizing (RACING).....	59
Layline steering (RACING).....	60
2.26 INFO menu	60
Course knob icon	62
INFO menu flowchart.....	62
INFO menu and Main Screen, active unit	63
INFO menu and Main Screen, inactive or locked unit	63
3 Installation.....	65
3.1 General	65
3.2 Installation checklist	65
3.3 Unpacking and handling	66
3.4 Determine system configuration	66
3.5 AP25 System Layout	67
3.6 RF300 Rudder feedback installation.....	67
3.7 Autopilot computer installation	69
3.8 Cable connections	70
3.9 Grounding and RFI	70
3.10 Drive unit installation.....	72
Connecting a reversible pump	74
Connecting a hydraulic linear drive.....	75
Connecting a solenoid valve	75
3.11 Control unit installation	76
Panel mounting	76
Alternative panel mounting.....	76
Optional bracket mounting	77
3.12 ROBNET2 network cables	77
AP27 connection.....	79
3.13 RC36 Rate Compass installation	79
3.14 RFC35 Fluxgate Compass installation	81
3.15 R3000X Remote Control installation	82

3.16	JS10 Joystick.....	82
3.17	S35 NFU Lever installation	82
3.18	Interfacing	83
3.19	SimNet.....	83
	SimNet network cables	84
	SimNet power and termination	84
3.20	Single NMEA input/output.....	89
3.21	Double NMEA input/output	89
3.22	NMEA output on Port 2.....	90
3.23	NMEA Compass input.....	90
3.24	Radar Clock/Data.....	91
3.25	IS15 Instrument installation	91
3.26	External Alarm.....	93
3.27	LF3000 Linear Feedback	93
4	Configuration and setup	95
4.1	First time turn on.....	95
4.2	Description of Installation Settings.....	96
4.3	Installation Menu	97
	Language selection.....	98
4.4	Dockside settings	100
	Boat type	100
	Drive unit voltage.....	101
	Rudder Feedback Calibration	101
	Rudder Test.....	103
	Drive engage	105
	Rudder Deadband.....	105
	Wind setup	106
	Minimum wind angle (NORMAL).....	106
	Minimum wind angle (RACING).....	107
	Tack angle (RACING).....	107
	Tack time (RACING).....	107
	Wind shift limit (RACING).....	108
	Dockside settings when configured for Virtual Feedback.....	109
4.5	Interface Settings.....	113

4.6	Display units	113
4.7	Sea Trial	114
	Set Rudder zero	115
	Minimum rudder	115
	Compass calibration	116
	Compass Offset	118
	Set Thrust Direction	119
	Wind Offset	120
	Wind damping	120
	Depth Offset	121
	Automatic tuning	121
	Transition Speed	123
	Init NAV	123
	NAV change limit	124
	Rudder play compensation	124
4.8	Parameters	125
	Manual parameter adjust	126
	Recall Autotuned?	128
4.9	Service Menu	128
	System Data Menu	129
	SimNet and NMEA Data Screen	129
	NMEA Port test (AC hardware)	130
	Simnet setup	131
	Master Reset	132
	Final sea trial	132
	Providing user training	133
5	Maintenance	135
5.1	Control unit	135
5.2	Autopilot Computer	135
5.3	Rudder Feedback	135
5.4	Compass	135
5.5	Drive unit	135
5.6	Exchange of software programme	136
	Autopilot Computer	136

	Autopilot Control Unit.....	137
6	Trouble shooting	139
6.1	Alarms	139
7	Spare Parts List.....	144
8	Technical Specifications	147
8.1	AP25 Autopilot System	147
8.2	AP25 Control Unit	149
8.3	Autopilot Computers.....	150
8.4	RC36 Rate compass	152
8.5	RFC35 Fluxgate compass	153
8.6	RF300 Rudder Feedback.....	153
8.7	R3000X Remote Control	155
8.8	JS10 Joystick.....	155
8.9	FU25 Steering Lever.....	156
8.10	IS15 Rudder	157
8.11	SimNet.....	158
8.12	IP protection.....	159
8.13	NMEA and SimNet messages.....	160
9	Glossary	164
10	Index.....	167
SALES AND SERVICE WORLDWIDE		

1 SYSTEM DESCRIPTION

1.1 General

Congratulations on the purchase of your new Simrad AP25 autopilot system and thank you for selecting what we feel is the most advanced autopilot system available on the market today.

Simrad manufactures a complete range of autopilots for all types of vessels, from recreational boats to merchant marine vessels. The company's involvement in autopilots began in 1953 with equipment for the North Sea fishing fleet under the brand name Robertson. Professional mariners around the world acknowledge that the Robertson and Simrad brand names are synonymous with the absolute best in autopilot technology.

The Simrad AP25 autopilot represents yet another step forward in autopilot technology with the intent of providing leisure boats between 30 and 80 foot with a host of new features. Among these the new Virtual Feedback algorithms in the autopilot software enable your autopilot to steer without having to mount a conventional rudder feedback unit.

The autopilot system can be expanded and enhanced with a selection of options and accessories.

The brain in the AP25 autopilot system is the single "intelligent" autopilot computer that communicates on the proprietary Robnet2 network to establish a reliable digital communication and power distribution network between the units in the autopilot system.

The AP25 autopilot is also equipped with the SimNet data and control network. SimNet provides high speed data transfer and control of Simrad products integrated in a total steering and navigation system.

1.2 How to use this manual

This manual is intended as a reference guide for operating, installing and maintaining the Simrad AP25 autopilot. Great care has been paid to simplify operation and set-up of the AP25.

Please take time to read this manual to get a thorough understanding of the operation and system components and their relationship to a complete AP25 autopilot system.

Other documentation material that is provided with your system includes a warranty card. This must be filled out by the authorized dealer that performed the installation and mailed in to activate the warranty.

1.3 System components

A basic AP25 system consists of the following units (refer to Figure 1-1):

- AP25 Control Unit with accessories
- Autopilot Computer
- Rate compass
- Rudder Feedback Unit with transmission link
- Drive unit

The basic system can be expanded with multiple fixed and hand held full function control units, hand held remote and steering lever.

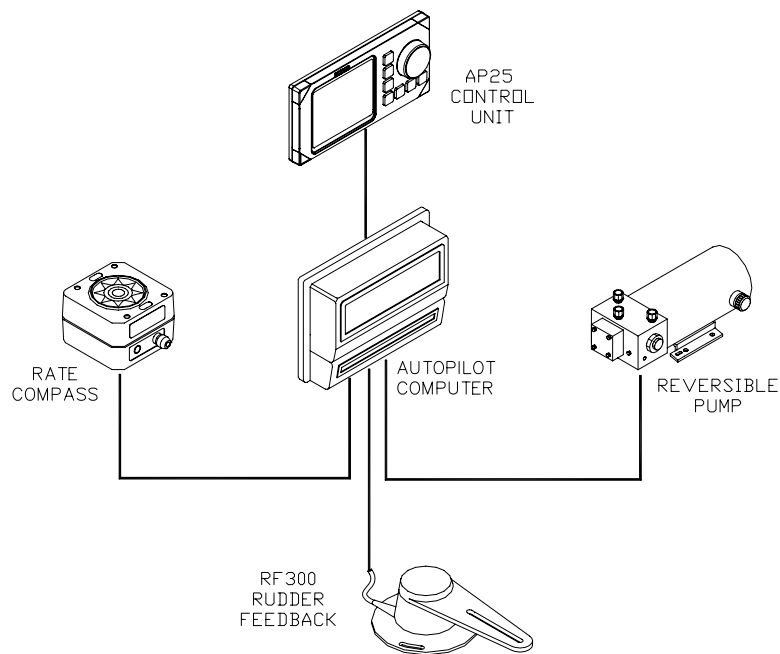

Figure 1-1 AP25 Basic system

1.4 AP25 Control Unit

A compact autopilot control for panel, bulkhead or bracket mounting. Large LCD 5" display for readout of autopilot data, mode keys and a rotary course knob. It has two Robnet2 connectors for system interconnection and expansion and two SimNet connectors for control and data sharing with other Simrad products. A NMEA2000 Adaptor Cable is available for interface through a SimNet port (page 146).

1.5 Autopilot Computer

The autopilot computer is the heart in the AP25 autopilot system. It contains the steering computer, interface to other system components, NMEA 0183 interface and drive electronics for the drive unit motor and clutch. Three models, AC10, AC20 and AC40 are available.

Autopilot computer comparison chart:

	AC10	AC20 (AC40)
Supply voltage	10-28 V	10-40 V
Motor current (continuous/peak)	6/12 A	10/20A (20/40A)
Clutch/bypass current	1,5 A*	1,5 A*
Number of control units	2	7
NMEA 0183 ports (input/output)	1	2
Solenoid output	x	x
Input for NFU control	x	x
External alarm		x
Radar clock/data interface		x
Input for NMEA compass		x

* 3A on later models

1.6 RF300 Rudder Feedback unit

Rudder feedback unit with transmission link and 10 m (30 feet) of cable. Transforms the angular travel of the rudder to a digital signal read by the autopilot steering computer.

1.7 Heading Sensors

The AP25 autopilot can be used with the following combinations of heading sensors:

RC36 Rate compass

Fluxgate compass with integrated rate sensor. Provides a dramatic improvement to the dynamic performance of both the autopilot and a stabilized radar display.

RC36 comes as standard with the autopilot.

RFC35 Electronic Fluxgate Compass (optional)

A compact heading sensor from Simrad with 15 m (45 feet) of cable. The direction of the earth's magnetic field is sensed by a floating ring core in a fluxgate coil and transformed to a digital signal read by the autopilot steering computer.

RFC35 can operate as a low cost back-up compass for the AP25 autopilot.

NMEA compass (optional)

A well performing compass that outputs NMEA 0183 HDT or HDG messages at 10 Hz can be connected directly to the AC20 or AC40 autopilot computer.

The AC10 Autopilot Computer has no port for NMEA compass input.

It is absolutely necessary for the autopilot that the heading rate is minimum 10 Hz.

Simrad gyrocompasses

Depending on the model there is direct NMEA0183 interface or you will need an optional GI51 interface unit to get NMEA0183 interface. Ask your Simrad dealer for information.

1.8 Optional equipment

A series of optional equipment are available for the basic AP25 system.

R3000X Remote Control

A small handheld remote control with two push buttons for power steering or course selection (port and starboard), and one push button with built-in lighted indicator for limited mode change.

JS10 Joystick

The JS10 Joystick is a Non-Follow-Up steering lever designed for indoor and outdoor console mount. It has a spring-loaded return-to-mid-position feature and is equipped with 10 m (33') of cable and installation hardware.

FU25 Follow-Up Steering Lever

Note !

Not applicable for Virtual feedback configuration (page 66).

The FU25 Follow-up steering lever features a dial with 5° rudder angle markings. The rudder will move and stop at the angle selected on the dial. The FU25 has a mid-position indent, buttons for (limited) mode selection, and mode indicators. It is designed for indoor and outdoor bulkhead or flush panel-mounting.

Refer to the FU25 manual for more information.

TI25 Thruster Interface

The TI25 Thruster Interface is designed to provide a control signal for operating a thruster interfaced to an AP25 system. It operates on/off solenoids, or a Danfoss PVEM valve. The Danfoss valve is a proportional valve that will provide full thruster performance with the output from TI25. The thruster output signal is calculated in the TI25 based on the mode of operation and the heading information. Set-up is from the control unit communicated via Robnet2. All settings are stored in the thruster interface unit.

Refer to the TI25 manual.

Multiple stations

Multiple control units can be added to the system. See comparison chart on page 11.

1.9 Software record

When the system is switched on, a status display shows the software versions for the control unit and the autopilot computer. See page 16.

Software version	Description
SW 1.1.00	First issue
SW 1.2.00	NoDrift mode implemented. Easy access to NAV source selection. Selectable NAV change limit implemented. Steering parameters can be changed in Auto mode. User Setup menu re-edited. Outboard selectable as boat type in dockside setup. Improvement in Wind mode algorithms. Depth contour pattern implemented. New INFO page showing SOG/Depth.
SW 1.2.01	Virtual feedback implemented.
SW 1.3.00	Anomalies in Setup and in French and German language repaired. Updated according to NMEA2000 ver. 1.100.

Note !

Units with SW 1.2.00 and onwards are not compatible with units with SW 1.1.00.

2 OPERATION

WARNING ! An autopilot is a very useful navigational aid, but **DOES NOT** under any circumstance replace a human navigator.

Do not use automatic steering when:

- In heavy traffic areas or in narrow waters
- In poor visibility or extreme sea conditions
- When in areas where use of autopilot is prohibited by law

When using an autopilot:

- Do not leave the helm unattended
- Do not place any magnetic material or equipment near heading sensor used in the autopilot system
- Verify at regular intervals course and position of vessel
- Always switch to Standby mode and reduce speed in due time to avoid hazardous situations

2.1 Overview

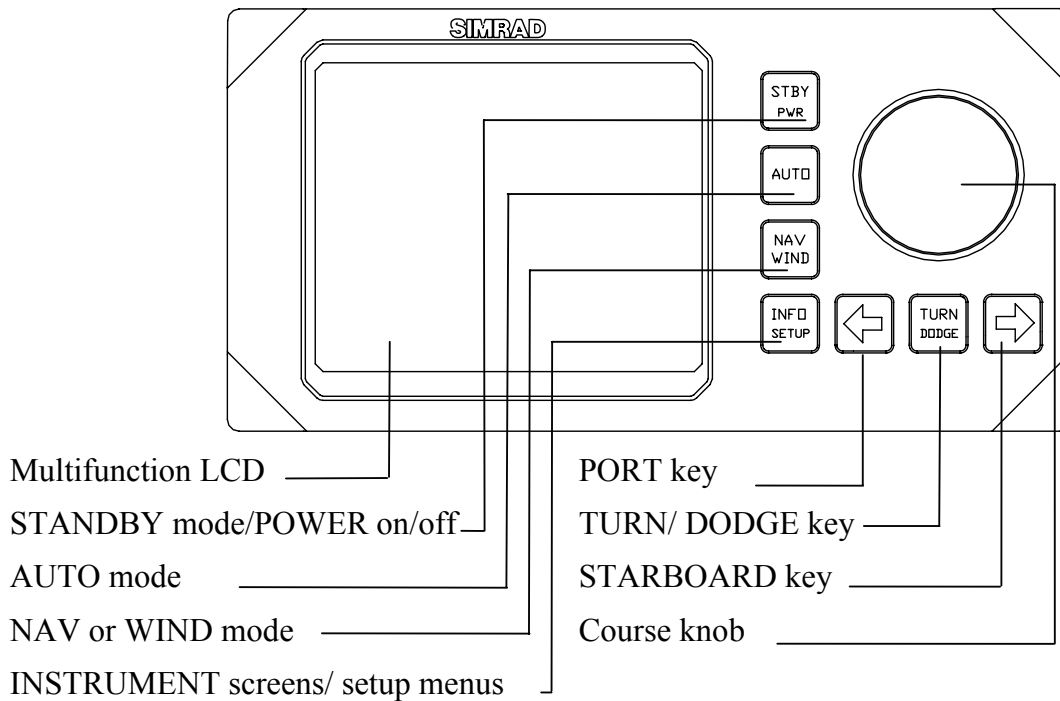



Figure 2-1 AP25 Front Panel

The control unit shown above can operate as a stand alone unit in an autopilot system or combined in a multistation system. In a multistation system the command can easily be transferred from one unit to another. Units not in control will display "Inactive" and/or .

The AP25 system is capable of the following primary steering modes: STBY (power steering), AUTO, NAV and WIND, each mode having a dedicated push button.

Each of the mode push buttons is clearly identified with the primary function in large text, and a secondary function listed in smaller text. Each button provides you with a multiple function mode display.

A group of user adjustable settings are provided in the AP25 User Setup Menu (page 50).

Alarms are presented in plain text to alert you of system and external data failure conditions. Alarms include both audible and visual presentations. The alarm listing is on page 139.

2.2 ON/OFF - Standby mode

Note !

At first time turn on see chapter 4.1.

A single press on the STBY button switches the system ON and the following status displays are shown:

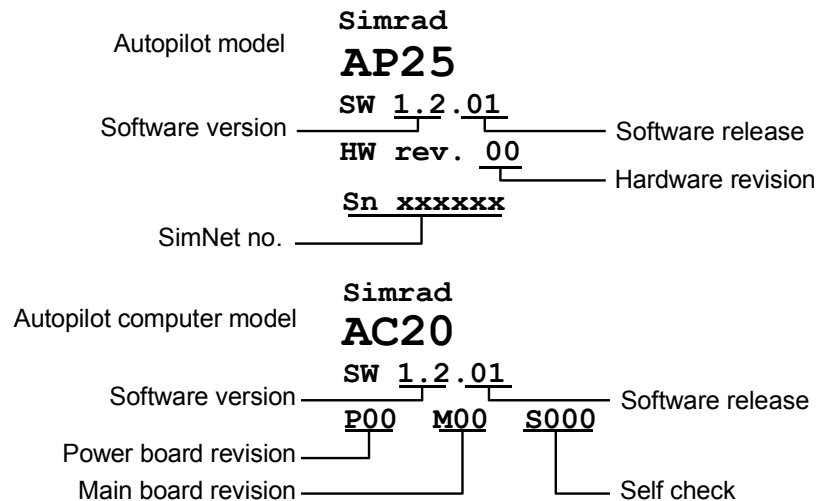

SW and HW revisions shown are examples only.

After approximately 5 seconds, the system is operative and the unit that was turned on will show the Standby mode display. Other units in a multistation system will display "Inactive". Control is transferred to any single unit by pressing its **STBY** button.

A long press (2-3 sec.) on the **STBY** button switches the system OFF and during this time, the alarm will sound.

Note !

*In an emergency, it is possible, on a multistation system, to turn OFF the system at any control unit by pressing the **STBY** button for 2-3 seconds.*

STBY mode is the mode that is used when steering the boat at the helm.

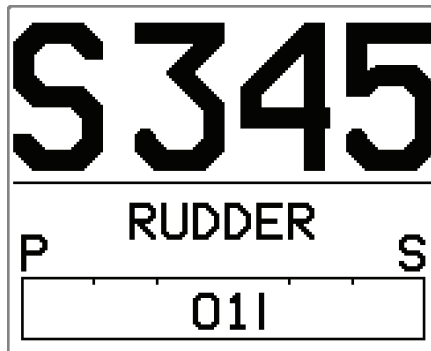

Display information:

- Standby mode
- Current heading 345°
- Rudder angle 1° to starboard.

Note !

When the autopilot operates on Virtual feedback, the numerical indication of the rudder angle is omitted.

Virtual feedback

See pages 67 and 109 about Virtual feedback.

Flashing course knob icon



When the course knob and the **PORT/STBD** buttons are used for settings etc., an icon will flash on the screen to tell that no course changes can be made unless you press the **AUTO** button.

Alarms

In the event there is an audible alarm with explaining text on the control unit, refer to section 6, Trouble shooting.

2.3 AP25 with MSD50 Stern Drive unit

Note ! *The information in section 2.3 only applies if your autopilot is driving a Simrad MSD50 Stern Drive.*

The MSD50 Stern drive unit has a relative feedback signal which needs a zero point setting after the autopilot has been turned on. Refer to the MSD50 manual for further information.

Zero point setting

Note ! *If you do not need a rudder angle display when leaving the dock, just steer the boat manually on a straight course and press the AUTO button. The zero point is then set automatically.*

If you prefer to use the rudder angle display when leaving the dock, proceed as follows:

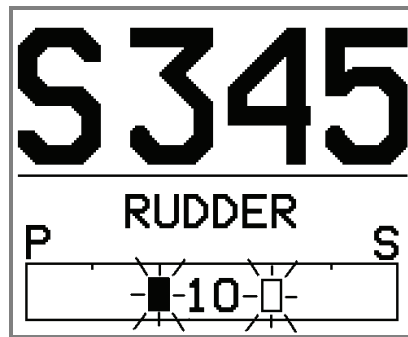

After turn on the rudder angle display will alternate between 10 degrees port and starboard to indicate that the "rudder" zero point need be set.

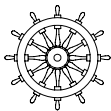

Use the wheel to bring the "rudder" to midship position. Turn the wheel from lock to lock (H.O. to H.O.) and count the exact number of turns. Then start from one lock position and turn the half number of turns.

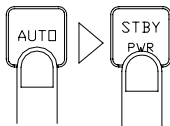

Press **AUTO** and then **STBY**. The zero point is now set and the display will show:

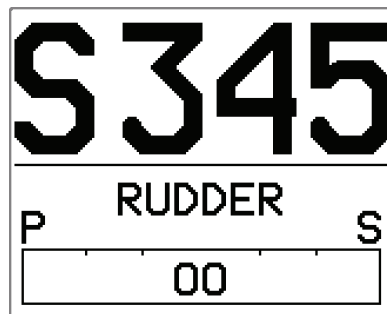

Follow the operating instructions on the following pages. There is no further need for zero point settings until next time you turn the autopilot on.

2.4 Follow-Up steering (FU)

Note ! *Not applicable for Virtual feedback configuration (page 67).*

In the Follow-Up steering mode the course knob may be used to set rudder commands. The commanded rudder angle is shown on the display and the rudder will move to the commanded angle and stop.

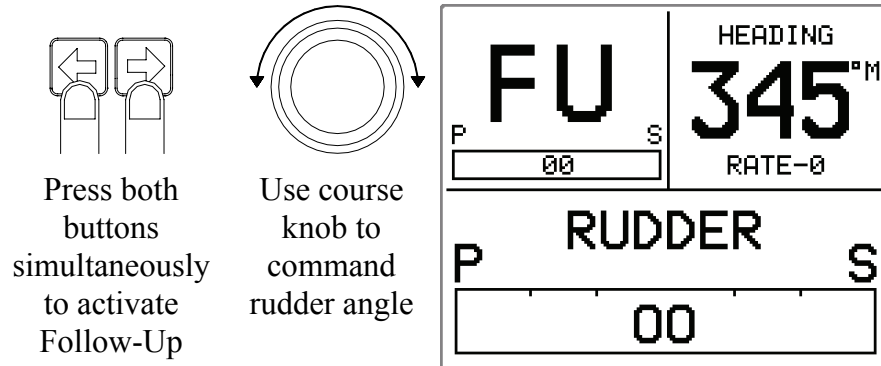

WARNING ! While in Follow-up mode you cannot take manual control of the wheel.



Return to manual control in Standby by pressing the **STBY** button

2.5 Non-Follow-Up steering (NFU)

In Standby mode, the NFU display is presented when the **PORT** or **STBD** button is pressed. The rudder will move as long as the button is pressed and the rudder angle is shown on the display.

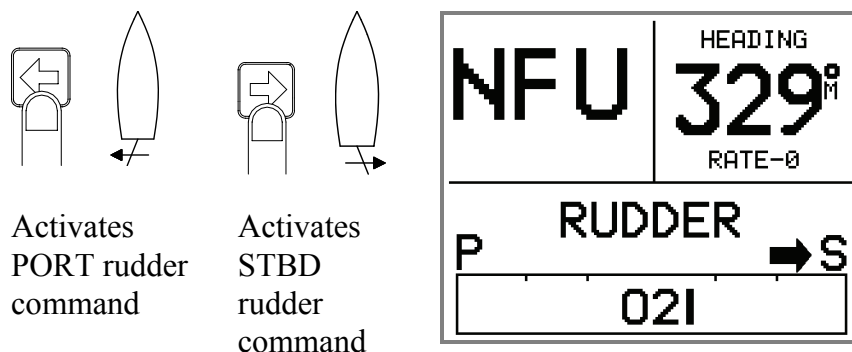

Note ! *When a NFU steering lever or remote control is operated, other control units become "Inactive".*

2.6 R3000X Remote Control (NFU)

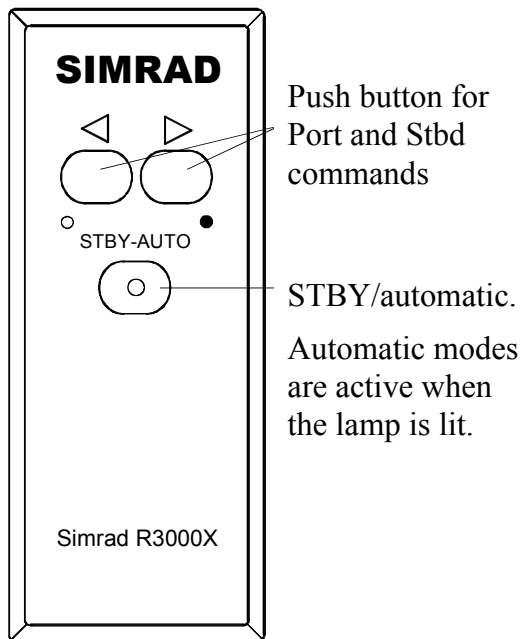

In STANDBY mode, the rudder will move as long as the Port or Stbd button is pressed.

In AUTO mode and Wind modes the set course or set wind angle will change 1° each time the button is pressed.

Note!

If you keep the button pressed, it will automatically change the setting in increments of 3° per second.

Mode changes are as per table below.

Initial mode	1 st press	2 nd press
STBY	AUTO	STBY
AUTO	STBY	AUTO
NAV	STBY	AUTO ¹⁾³⁾
STBY	WIND	STBY ²⁾
AUTO	STBY	WIND ²⁾
WIND	STBY	WIND ²⁾
WINDN	STBY	WIND ³⁾

Notes !

1. When NAV mode is selected in User Setup
2. When WIND mode is selected in User Setup
3. NAV and WIND_N modes can only be entered from the Control unit because you have to accept the prompt displays.

2.7 JS10 Joystick (NFU)

The principle is similar to that of R3000X Remote Control (see above). The rudder will move as long as the lever is offset to Port or Starboard. JS10 has no mode change feature.

Note !

When a NFU steering lever or a remote control is operated, the control units and FU25 become "Inactive".

2.8 Automatic Steering

When AUTO mode is selected, the AP25 automatically picks the current boat heading as the set course and maintains the simultaneous rudder angle. This gives a bumpless transfer at the mode change.

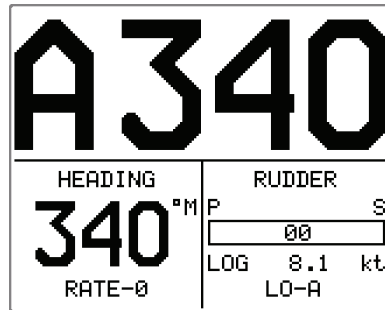

Automatic steering mode
 Set course: 340 degrees
 Compass reading: 340°M
 Heading source: Rate compass
 Rudder angle: 00°
 Speed: 8.1 kt water speed from the log
 Steering parameter: LO-A

The AP25 will keep the boat on the set course until a new mode is selected or a new course is set with the course knob or the **PORT** or **STBD** buttons. One revolution of the course knob equals a 45° course change.



Decrease Increase

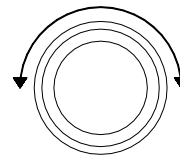

Course adjust 1°
 (or 10°)/ push Course change
 CCW: Decrease CW: Increase

Note !

On power boats it is possible in the User Setup menu to set the buttons to change the course by 10° per press (see page 55).

Once the course is changed to a new set course, the boat will automatically turn to the new heading and continue to steer straight.

Heading capture

When in AUTO or NoDrift modes this feature allows you to automatically cancel the turn you are in by an instant press on the **AUTO** or **NAV** button (NoDrift). The autopilot will counteract the turn and the boat will continue straight ahead on the heading read from the compass the very moment you pressed the **AUTO** or **NAV** (NoDrift) button.

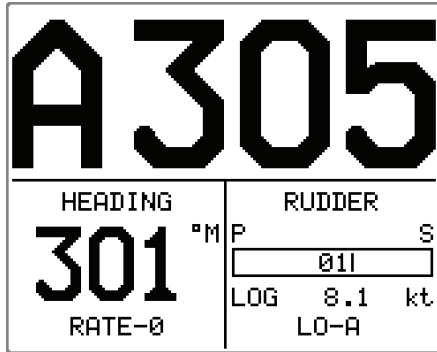

Automatic steering mode
 New “captured” heading: 305 degrees
 Compass reading: 301° M (Magnetic) or T (True)
 Heading source: Rate compass
 Rudder angle: 01° to stbd.
 Speed: 8.1 kt water speed from the log
 Steering parameter: LO-A

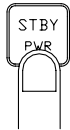

Regain manual steering by pressing the **STBY** button

2.9 Automatic control of steering parameters

The AP25 provides two different sets of steering parameters for controlling the response of the boat at different speeds or wind directions while in AUTO, NAV or WIND modes.

Power boat

The AP25 selects the LO (response) steering parameters when engaging an automatic mode from STBY provided there is no speed input. This is a safety feature. When entering an automatic mode at low speed, the steering parameters may be changed to HI automatically by input data from a speed log or a GPS navigator, or manually.

The speed at which the AP25 automatically changes from LO to HI parameters (or opposite) is determined by the "Transition Speed" set in the Installation Setup Menu (Sea trial). See diagram below.

Legend

- HI-A High response parameters set automatically
- LO-A Low response parameters set automatically
- HI-M High response parameters set manually
- LO-M Low response parameter set manually

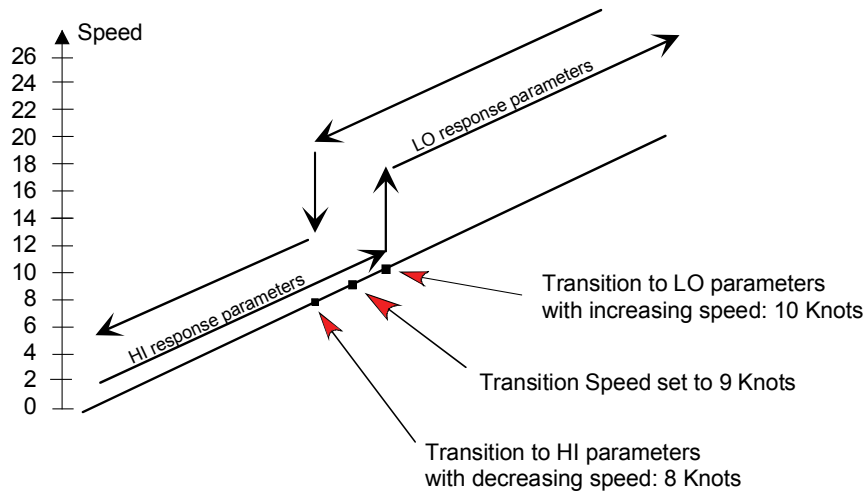

Sailboat

When sailing in WIND mode, the parameters are automatically changed by the direction of the wind as per below or by the boat speed.

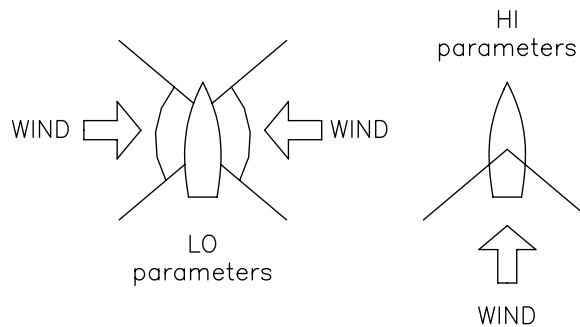

The transition between HI and LO parameters and vice versa will have a different characteristics with regards to the wind angle compared with the transition controlled by the speed of the boat.

If you loose too much speed e.g. when tacking, the parameters will change to HI to gain sufficient rudder response. This should be observed when setting the transition speed on sailboats.

2.10 Manual Selection of HI/LO Parameters

Manual selection of HI/LO parameters is necessary if there is no speed input to the autopilot or if you want to override the automatic control.

To toggle between LO and HI parameters, press the "AUTO" button two times quickly.

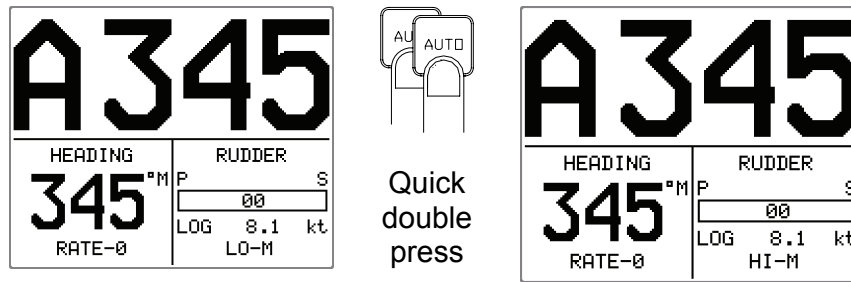

Notes !

1. If you are in NAV or WIND modes you need not enter AUTO mode to manually change the parameter set. Just make a quick double press on the AUTO button.
2. The manually selected setting (HI or LO) will override the automatic selection and remain in effect until you re-enter any automatic mode from STBY.

2.11 PATTERN steering

The AP25 offers a number of different pattern steering features when in AUTO mode. The U-turn pattern is always available. Other turn patterns can be selected under the User Set-up 2 menu. Refer to Turn Pattern select on page 55.

U-turn

This feature is very useful in a man overboard situation and whenever you want to steer back on a reciprocal heading.

U-Turn changes the current set course to be 180 degrees in the opposite direction. The user must decide whether the U-Turn should be made to Port or Starboard when bringing the boat on the new course. U-Turn is activated by a quick press on the **TURN/DODGE** button. The AP25 will continue on the set course until you press either the **PORT** or **STBD** button to select the direction to make the U-Turn. If you do not press **PORT** or **STBD** within 1 minute, the AP25 will return to the AUTO mode and stay on course.

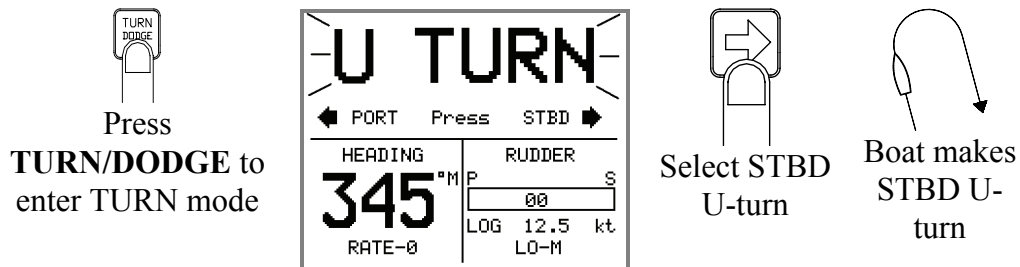

C-turn

The AP25 provides a continuous turn feature when in AUTO mode. This may be used for circling fish or a particular object on the seabed.

C-turn makes the boat turn in a circle with a constant rate of turn. The user decides whether the C-turn should be made to Port or to Starboard.

Ensure that the C-turn pattern has been selected under the User Set-up 2 menu. Refer to Turn Pattern select on page 55.

To enter C-turn mode:

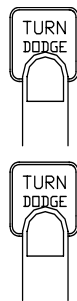

First select U-turn with a press of the **TURN/DODGE** button.

Then select C-turn by another press of the **TURN/DODGE** button.

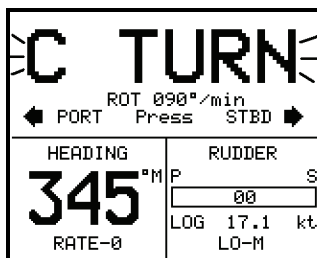

The AP25 will continue on the set course until you press either the **PORT** or **STBD** button to select the direction in which to make the C-turn. If you do not press **PORT** or **STBD** within 1 minute, the autopilot will return to AUTO mode and stay on course.

The turn rate can be adjusted before the turn is initiated and during the turn. Increasing the turn rate yields to a smaller circle and vice versa.

To exit C-turn mode, press any of the mode buttons. When pressing the **AUTO** button, the new set course is shown in the upper portion of the display.

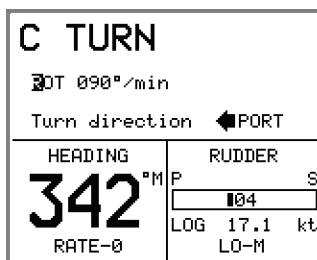

Boat turning port

Spiral-turn

The spiral turn feature may also be used for circling fish or when searching a particular object on the seabed.

Spiral-turn makes the boat turn in a spiral with a decreasing or increasing rate of turn. The user decides whether the spiral-turn should be made to Port or Starboard.

Ensure that the Spiral-turn pattern has been selected under the User Set-up 2 menu. Refer to Turn Pattern select on page 55.

To enter Spiral turn mode:

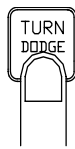

Press the **TURN/DODGE** button repeatedly until SPIRAL is flashing in the display.

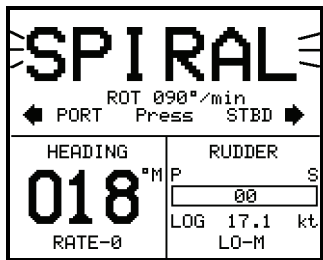

The initial rate of turn can be adjusted before the turn is initiated. Increasing the ROT yields to a smaller circle and vice versa. Adjustable range is 10 to 600°/min.

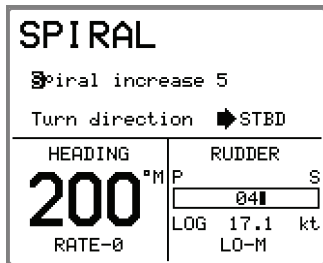

The AP25 will continue on the set course until you press either the **PORT** or **STBD** button to select the direction in which to make the spiral turn. If you do not press **PORT** or **STBD** within 1 minute, the autopilot will return to **AUTO** mode and stay on course.

Select “spiral increase” to move outwards in the spiral and “spiral decrease” to move inwards. Higher number gives a wider spiral. When Spiral 0 the boat will turn in a circle. Range: 0-9.

Boat turning starboard

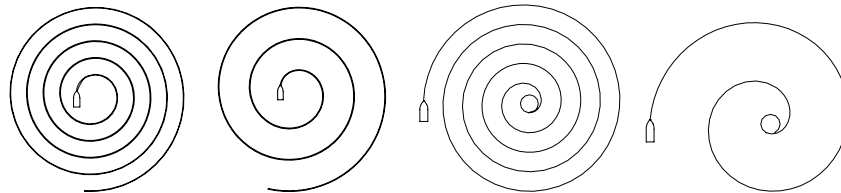

Increase 1

Increase 5

Decrease 1

Decrease 5

To exit spiral-turn mode, press any of the mode buttons. When pressing the **AUTO** button, the new set course is shown in the upper portion of the display.

Zigzag-turns

A zigzag turn pattern is also available when in AUTO mode.

The user decides whether the first turn should be made to Port or Starboard.

Ensure that the zigzag-turn pattern has been selected under the User Set-up 2 menu. Refer to Turn Pattern select on page 55.

To enter zigzag turn mode:

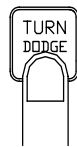

Press of the **TURN/DODGE** button repeatedly until ZIGZAG is flashing in the display.

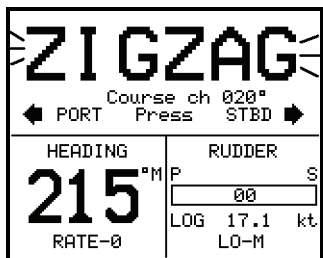

The course change can be set before the turn is initiated. (Range: 2-70°).

The AP25 will continue on the set course until you press either the **PORT** or **STBD** button to select the direction in which to make the first course change. If you do not press **PORT** or **STBD** within 1 minute, the autopilot will return to AUTO mode and stay on course.



While sailing in a zigzag pattern you can alter the course change (4-140°), time on the leg (1-20 min.), and the set course. An arrow shows the direction of the course change.

Boat turning starboard

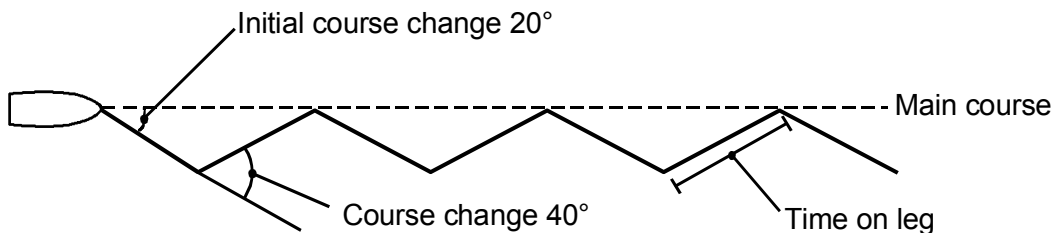

To exit zigzag-turn mode, press any of the mode buttons. When pressing the **AUTO** button, the new set course is shown in the upper portion of the display.

Square-turn

The square turn feature in AUTO mode can also be made a rectangle or any pattern when the next turn is 90°.

The user decides whether the first turn should be to Port or Starboard.

Ensure that the Square-turn pattern has been selected under the User Set-up 2 menu. Refer to Turn Pattern select on page 55.

To enter Square turn mode:

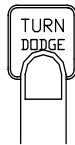

Press of the **TURN/DODGE** button repeatedly until **SQUARE** is flashing in the display.

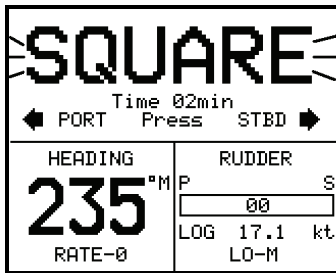

The time between each 90° course change can be adjusted before the turn is initiated (1-30 min.).

The AP25 will continue on the set course until you press either the **PORT** or **STBD** button to select the direction in which to make the first course change. If you do not press **PORT** or **STBD** within 1 minute, the autopilot will return to AUTO mode and stay on course.

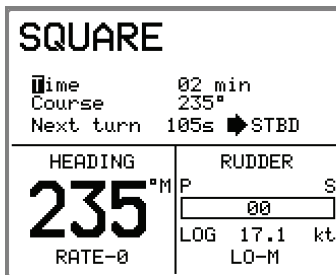

When the square turn is selected you can change the time between each course change (1-20 min.) hence the length of the leg. While you are on the leg you can also change the time and thus change the shape of the pattern. You can also at any time change the set course.

Boat turning to starboard

To exit square-turn mode, press any of the mode buttons. When pressing the **AUTO** button, the new set course is shown in the upper portion of the display.

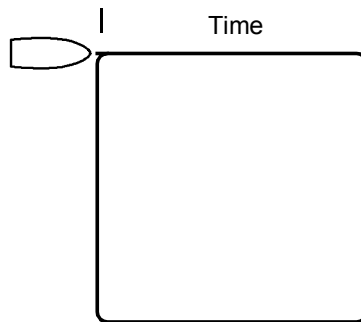

Lazy S-turn

The AP25 also provides a lazy S-turn feature when in AUTO mode.

The user decides whether the initial turn should be made to Port or to Starboard.

Ensure that the lazy S-turn pattern has been selected under the User Set-up 2 menu. Refer to Turn Pattern select on page 55.

To enter Lazy S-turn mode:



Press of the **TURN/DODGE** button repeatedly until LAZY S is flashing in the display.

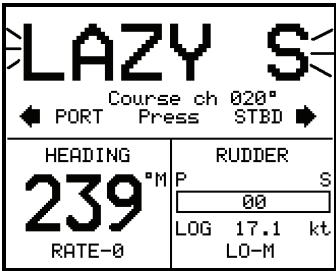

The course change can be adjusted before the turn is initiated (2-80°).

The AP25 will continue on the set course until you press either the **PORT** or **STBD** button to select the direction in which to make the first course change. If you do not press **PORT** or **STBD** within 1 minute, the autopilot will return to AUTO mode and stay on course.

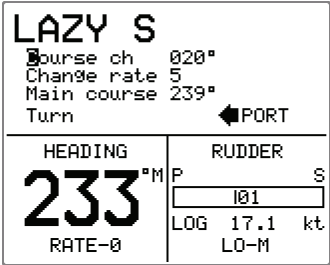

While in a Lazy-S pattern you can alter the course change magnitude (4-160°), the frequency or rate of change (1-9) and the main course. An arrow shows the direction of the turn.

Boat turning to port

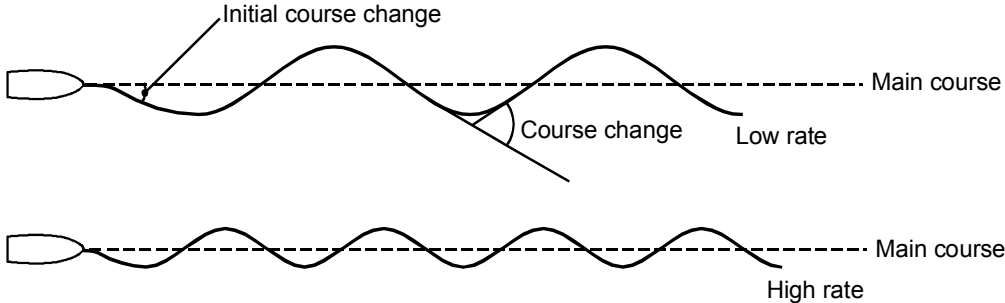

To exit Lazy S-turn mode, press any of the mode buttons. When pressing the **AUTO** button, the new set course is shown in the upper portion of the display.

Depth Contour

Steering to a depth contour is also an AUTO mode feature. With input from an echo sounder, the autopilot can be set to steer the boat to a set depth. This is very useful if you want to follow a depth contour.

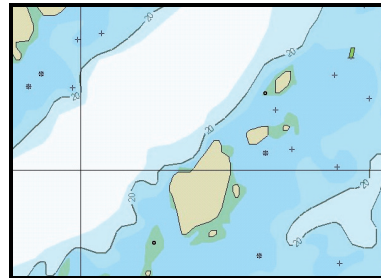

Smooth seabed

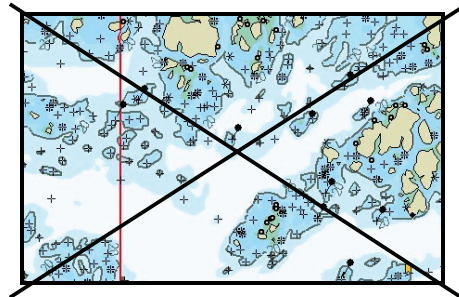

Rocky waters

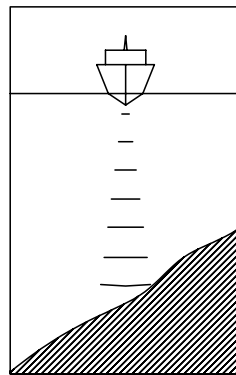

Slope

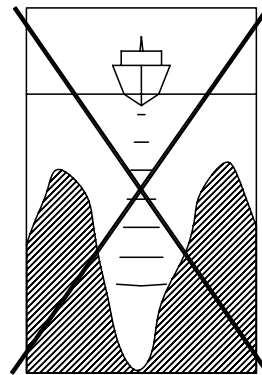

Narrow channel

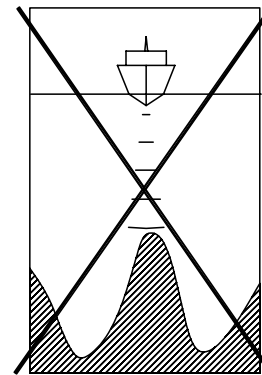

Ridge

Caution !

Do not use this feature unless the seabed is suitable. Do not use it in rocky waters where the depth is varying significantly over a small area.

Ensure that the depth-turn pattern has been selected under the User Set-up menu. Refer to Turn Pattern select on page 55.

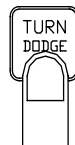

Make sure you have depth reading available in the system. Press the **TURN/DODGE** button repeatedly until DEPTH is flashing in the display. The actual depth reading is shown on the display.

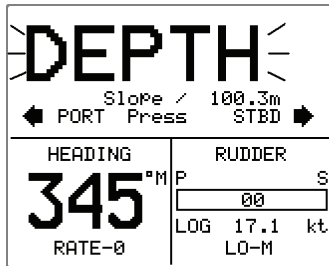

Select depth slope with the course knob. “/” means shallow is to starboard, “\” means shallow to port. Steer the boat to the depth you want to track and in the direction of the depth contour (main course). When the wanted depth is shown in the display, activate the depth contour steering with **PORT** or **STBD** button (any of the two).

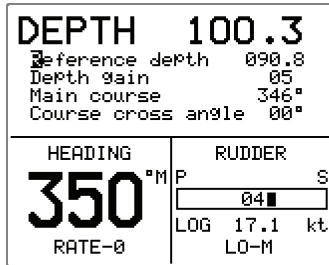

If you do not press **PORT** or **STBD** within 1 minute, the autopilot will return to AUTO mode and stay on course.

The display has the following menu items:

Reference depth

The reference depth is captured when the Depth pattern is activated. To change the reference simply use the **PORT** or **STBD** button or the course knob.

Depth gain

The autopilot is tracking the depth by computing an x-track error when the boat is off the reference depth. This error automatically adjusts the set course to bring the boat back on track.

Use the gain control to have a firm or smooth response to the variation in depth.

Range: (05-95)

Main course

This should be the main (average) direction of the depth contour you want to follow. If the contour line is making a big change in direction, you should manually adjust the set course to the new direction. This will result in a quicker response from the autopilot. If the course is not adjusted, the autopilot will need more time to turn and steer the boat back to the reference depth.

Contour Cross Angle (CCA)

With this parameter you can make the boat lazy-s across your reference depth. With the CCA set to zero there is no S-ing. The CCA is an angle that is added to or subtracted from the set

course. Each time the boat crosses the reference depth the sign (+/-) of the CCA is changed and makes the boat turn to cross the reference depth contour in the opposite direction. The larger the CCA the bigger the turn.

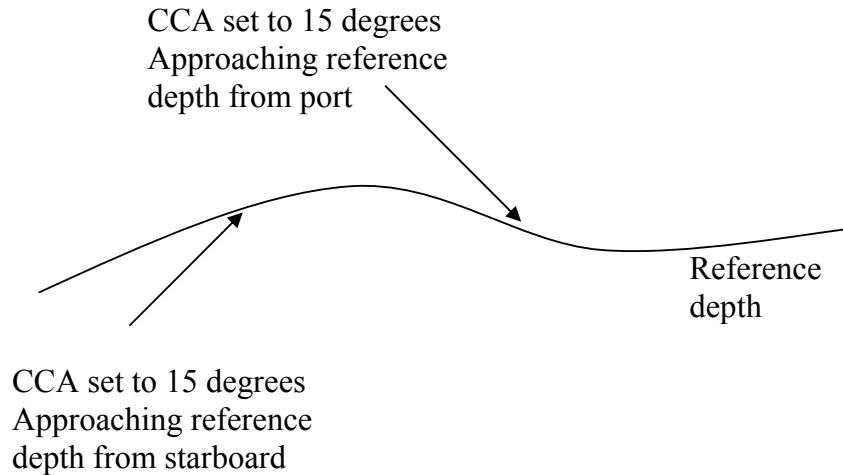

Range: (0-50)

2.12 Dodge in AUTO

Dodging is useful in situations where you need to quickly take control of the helm to steer around an obstruction, and then resume the previous set heading. Dodging is activated by a quick double press on the **TURN/DODGE** button.

When in DODGE mode the displayed set course is the last one set prior to activating the dodge function. When DODGE is displayed, the AP25 is no longer in control of the steering, and you must either manually steer the boat in STBY mode or take control using Non Follow Up or Follow Up steering. On manual steering (STBY mode) the clutch or bypass valve in the drive unit will be disengaged. The AP25 will remain in the DODGE mode until you exit DODGE by a second press on the **TURN/DODGE** button or select a mode.

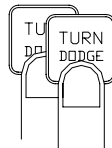

Quick double press on **TURN/DODGE** to activate Dodge mode

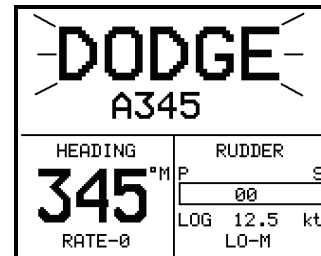

Perform dodging in one of the following ways:

1. Manually steer the boat by the wheel:

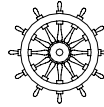

2. Non Follow Up steering by pressing:

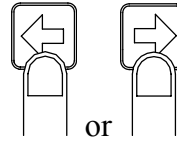

or using NFU steering lever

3. Follow Up steering by pressing both:

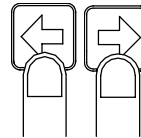

and using the course knob

To return from Dodge mode, press one of the following:

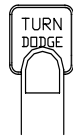

Selects AUTO mode and returns to the last set course

or



Selects AUTO mode with the current heading as the set course

Note !

Using NFU or FU modes while dodging will make "NFU" or "FU" flash instead of "DODGE".

2.13 Thruster Steering (optional)

If the boat is equipped with an appropriate thruster (page 13), it can be connected to the AP25 system and the boat can then be controlled by rudder and thruster.

When the AP25 is controlling the thruster you may:

- Have excellent course and track keeping performance at very low speeds (AUTO or NAV modes).
- Have automatic heading control when stationary, e.g. keep the bow into the wind and/or the waves.
- Provided the warf has no steel construction you can use AUTO mode to keep the bow steady when docking.

A thruster icon below the mode index confirms that a thruster is connected to the system (via TI25 Thruster Interface).

From the User Set-up Menu (page 52) you can switch the thruster on and off. When the thruster is switched on, both rudder and thruster is used to maintain the heading. If the boat speed exceeds 6 knots the thruster is automatically disabled.

Examples of display pictures:

STANDBY
Non-Follow Up
steering mode

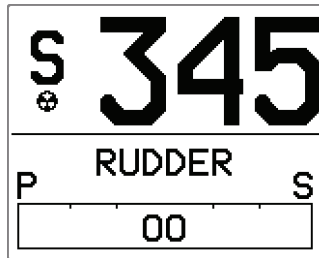

Heading to be maintained by rudder

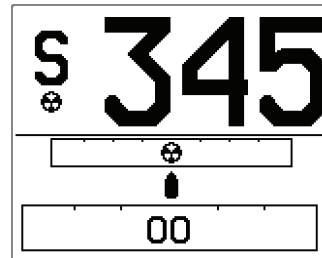

Heading to be maintained by rudder and thruster

AUTO mode

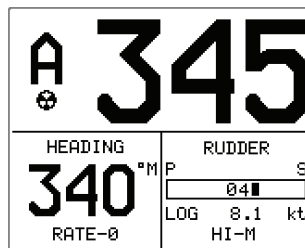

Heading maintained by rudder

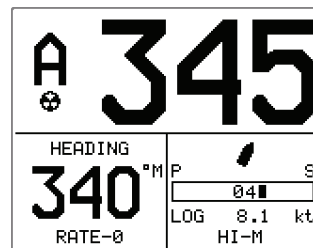

Heading maintained by rudder and thruster

Note !

When operating an On/Off thruster be aware that most electrical thrusters have a built in thermal cut-off switch. The switch will shut off the motor if it is overheating and re-engage it when it has cooled down. The water temperature also affects the running time. The On/Off thruster may only run for a few minutes, and the total running time for a longer period should be limited by increasing the thruster sensitivity value (see page 57).

2.14 Tacking in Auto mode

The tack function is only available in sailboats when the system is set up for SAIL boat type in the installation setup.

Tacking in AUTO mode is different from tacking in WIND mode. In AUTO mode the tack angle is fixed and can be set in the Installation/Dockside menu. Default tack angle is 100°.

Tacking should only be performed into the wind and must be tried out in calm sea conditions with light wind to find out how it works on your boat. Due to a wide range of boat characteristics (from cruising to racing boats) the performance of the tack function may vary from boat to boat. Except for the fixed course change and the difference in displays, the procedure is similar to that of the U-Turn described on page 24.

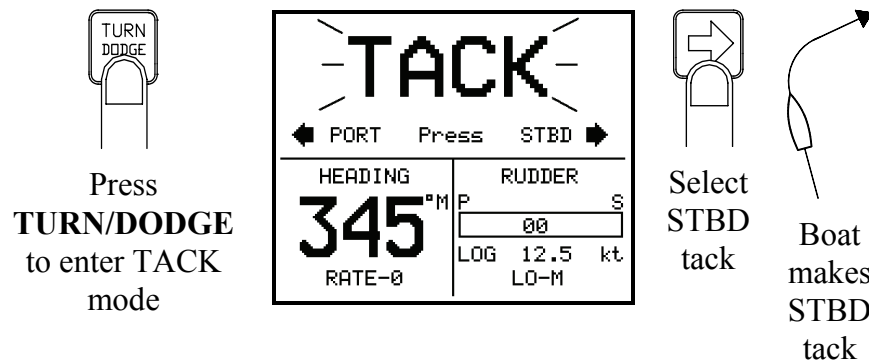

2.15 NoDrift

Note !

The source when operating in NoDrift mode is the Position (Pos) source.

The NoDrift mode is an alternative to route steering in NAV mode, and is automatically entered when you press the **NAV WIND** button provided NoDrift has been selected in the (user) SETUP menu.

The autopilot will steer to an imaginary waypoint and the bearing is the boat's heading at the very moment the NoDrift mode is engaged.

Unlike when in Auto mode the vessel will steer a course equal to the bearing line unaffected by wind and current (no drift).

The course to steer to (bearing line) can be changed the same way as when changing course in Auto mode.

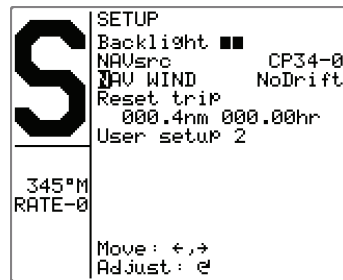

Select NoDrift in the Setup menu when in STANDBY or AUTO mode. Press the **NAV WIND** button to enter NoDrift mode. The **NAV WIND** key is now programmed to always activate the NoDrift mode. If you want the key to activate NAV mode, enter the User Setup menu and select NAV.

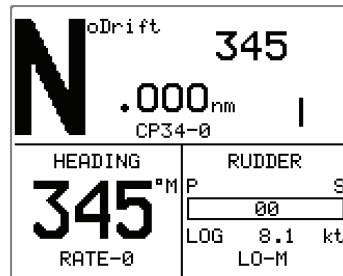
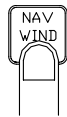

NoDrift mode

Set course: 345

NoDrift indicator: 0.000nm

Pos Source: CP34

Heading: 345°M

Note !

To operate in NoDrift mode your GPS/chart plotter must be turned on.

Dodge in NoDrift mode

This is similar to dodging in Auto mode.

2.16 Navigating with the AP25

Note ! *The source when operating in NAV mode is the Navigation (Nav) source.*

The AP25 has the capability to use steering information from an external navigator (GPS, Chart Plotter) to direct the boat to a specific waypoint location, or through a route of waypoints. In the NAV mode, the AP25 uses the compass as heading source for course keeping. The information received from the navigator alters the set course to keep the boat on the track line and direct the AP25 to the destination waypoint.

Note ! *Navigational steering should only be used in open waters. By selecting the NAV mode, the AP25 is set for automatic steering on the current set course and then waits for the user to accept the course change to the track line or destination waypoint.*

To obtain satisfactory navigation steering, the following points must be fulfilled prior to entering the NAV mode:

- The AP25 autosteering must be tested and determined satisfactory.
- The navigation receiver (GPS, Chart Plotter) must be in full operating mode with adequate signal characteristics for valid position and navigation data.
- At least one waypoint must be entered and selected as the current “Go to” waypoint.
- The navigation receiver (source) for the autopilot will be the one that is automatically selected in the interface set-up or manually selected in the User setup2 menu item called “Source select” (page 52).

The AP25 is designed to steer in “mixed mode” operation. This combines the straight steering capability of cross track error (XTE) steering in conjunction with the turning capability of bearing mode steering (Course To Steer, CTS) and automatic Waypoint shift.

Note ! *If the AP25 is connected to a navigation receiver that does not transmit a message with bearing to next waypoint, it will pick a XTE message and steer on Cross Track Error only. In that case you have to revert to AUTO mode at each waypoint and manually change set course to equal bearing to next waypoint and then select NAV mode again.*

Press the **NAV** button to activate the NAV prompt display.

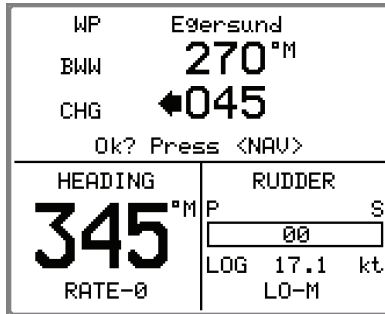

The prompt display shows the name or number of the next waypoint (WP), the bearing of the track line (BWW) from the previous waypoint to the destination waypoint, the required course change (CHG) and the direction in which the boat will turn.

Note !

If only one waypoint has been entered the bearing will be from the present position to the destination waypoint.

The lower left portion shows the compass heading and the lower right portion shows the rudder angle and speed.

Press the NAV button again to accept the waypoint as the location to steer towards. The autopilot turns the boat onto the track line.

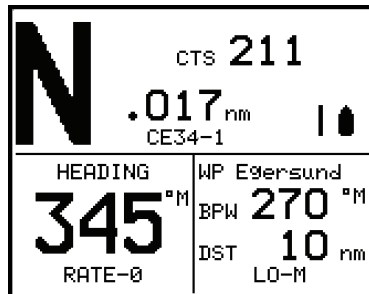

- NAV mode
- Course to steer (CTS): 211 is set internally by the autopilot to steer the boat onto the track line.
- Cross track error (XTE): 0.017 nm to stbd.
- NAV data source: CE34-1
- Compass heading: 345° M.
- Next waypoint: Egersund
- Bearing from current position to the next waypoint (BPW) : 270°M
- Distance to waypoint: 10 nm

Note !

For Cross Track Error, the number of decimals shown depends on the output from the GPS/chart plotter. Three decimals give a more accurate track keeping.

When operating the AP25 in NAV mode to steer through a route of waypoints, the AP25 will steer to the first waypoint in the route after you accept the first waypoint as the location to steer towards. When you arrive at the waypoint, the AP25 will output an audible warning, display an alert screen with the new course information, and automatically change course onto the new leg.

Note !

If the required course change is more than the NAV change limit (default 10°), you have to verify that the upcoming course change is acceptable. This is a safety feature. See page 124 on how to change the 'NAV change limit'.

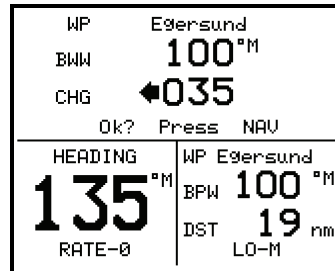
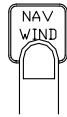

Alert screen. Press NAV button to verify course change larger than 10°.

If no verification is received, the AP25 will continue on the current set course in AUTO mode.

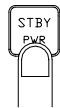

Regain manual steering by pressing the **STBY** button

Setting the waypoint arrival circle

For route navigation it is recommended to use automatic waypoint shift/change at a set waypoint arrival circle.

The arrival circle should be adjusted according to boat speed. The higher speed, the wider circle. The intention is to make the autopilot start the heading change in due time to make a smooth turn onto the next leg.

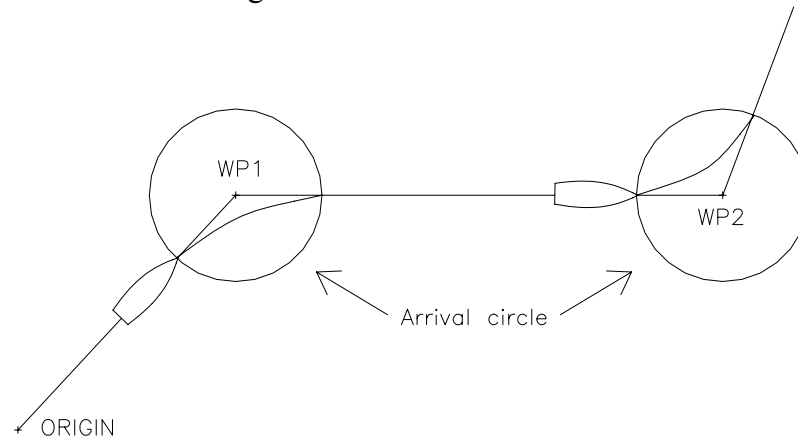

The figure below may be used to select the appropriate waypoint circle on the GPS/chart plotter.

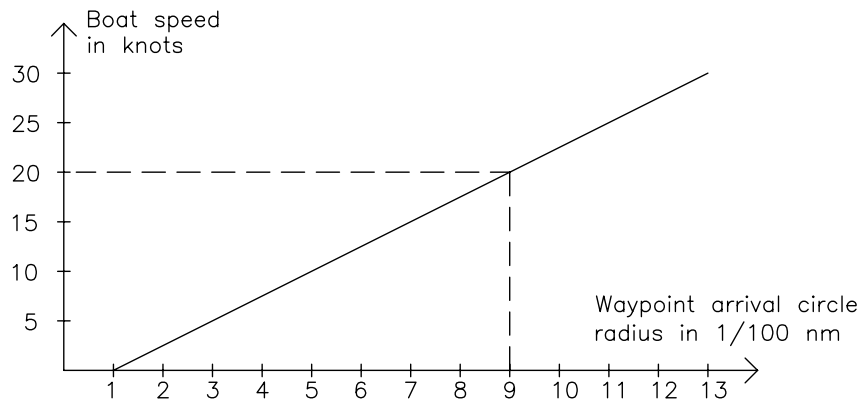

Example: With the speed of 20 knots you should use a waypoint circle with radius 0.09 nm.

Note ! *The distance between any waypoints in a route must not be smaller than the radius of the waypoint arrival circle when using automatic waypoint shift.*

2.17 Dodge in NAV

When dodging in NAV mode, the course displayed as Course To Steer (CTS) is the boat's recommended heading. However, the previous set course is stored by the AP25. When DODGE is flashing on the display, the AP25 is no longer in control of the steering and you must either steer the boat manually or take control using either Non-Follow-up steering or Follow-up steering. On manual steering, the clutch (or bypass valve) in the drive unit will be disengaged when dodging. The AP25 will remain in the DODGE mode until you exit DODGE by a second press on the **TURN/DODGE** button or until you select another mode.

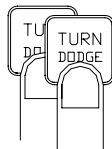

Perform dodging the same way as in AUTO mode above.

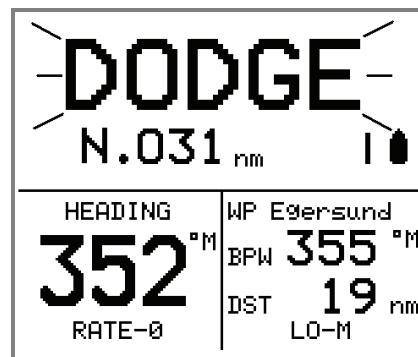

Quick double press on **TURN/DODGE** to activate Dodge mode

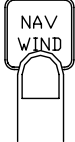

To return from Dodge mode, press one of the following:

1.  Returns to NAV mode at present position with a new NAV prompt. Keeps all offset estimates (Wind/current etc.) in the algorithms (recommended).
2.  Selects NAV mode at present position with a new NAV prompt. May result in a less accurate return to the track.
3.  Selects AUTO mode with the current heading as the set course.

2.18 Selecting a different Navigation source

If you have more than one navigation source connected to the AP25, you will be able to choose any for navigation. Refer to the “*Source select*” item in the User Set-up 2 menu for details on selecting a different navigator (page 52).

2.19 Wind vane steering

Prior to entering WIND mode the AP25 system should be operating in AUTO, with valid input from the selected wind transducer. The WIND mode is only available if the system has been set up for SAIL-boat in the Installation/Dockside Menu, and the NAV/WIND source is set to WIND under the USER SETUP menu. (Refer to page 50).

Enter the WIND mode by pressing the **NAV/WIND** button.

The set course to steer (CTS) and set wind angle are entered from the compass heading and the wind transducer when at the moment the WIND-mode is selected. From that point the autopilot will change the course to maintain the wind angle as the wind direction may change.

Note !

If the cumulative shift of the wind direction exceeds a set limit from the time a new wind angle is set, a WIND SHIFT alarm will sound.

The display will show the set wind angle. Adjustments to this set angle can be made by using the course knob or **PORT** or **STBD** button.

The display also presents heading and rudder angle.

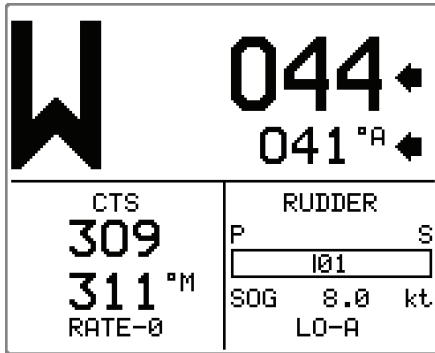

Wind (vane) mode

Set wind angle: 044 degrees from stbd.

Measured wind angle: 041°A (apparent)
(T = True)

Course to steer: 309°

Compass reading: 311° M (magnetic)
T (true)

Heading source: Rate compass

Rudder angle: 01° to port

Speed over ground (SOG): 8.0 kts

Parameter: LO-A (Low response, automatic set)



Steer port



Steer stbd.

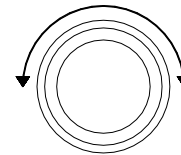

Adjust set wind angle 1°/push

Major wind angle adjust
CCW: Steer port CW: Steer stbd

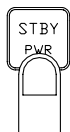

Regain manual steering by pressing the **STBY** button

2.20 Tacking and gybing in Wind mode

In WIND mode there is a tacking and gybing aid function.

Tacking in WIND mode as compared to AUTO mode can be performed when sailing with apparent or true wind as the reference, and with a true wind angle of less than 90 degrees.

The tacking operation will immediately mirror the set wind angle to the opposite side. A tacking-message will flash on the display for 5 seconds. Any new command given when the message is flashing, will interrupt the tack operation. The rate of turn during the tack will be given by the 'Tack time' parameter set in the Installation/Dockside menu (page 107).

A quick press on the **TURN/DODGE** button will activate the tack function and the boat will start turning to the same wind angle on the other side.

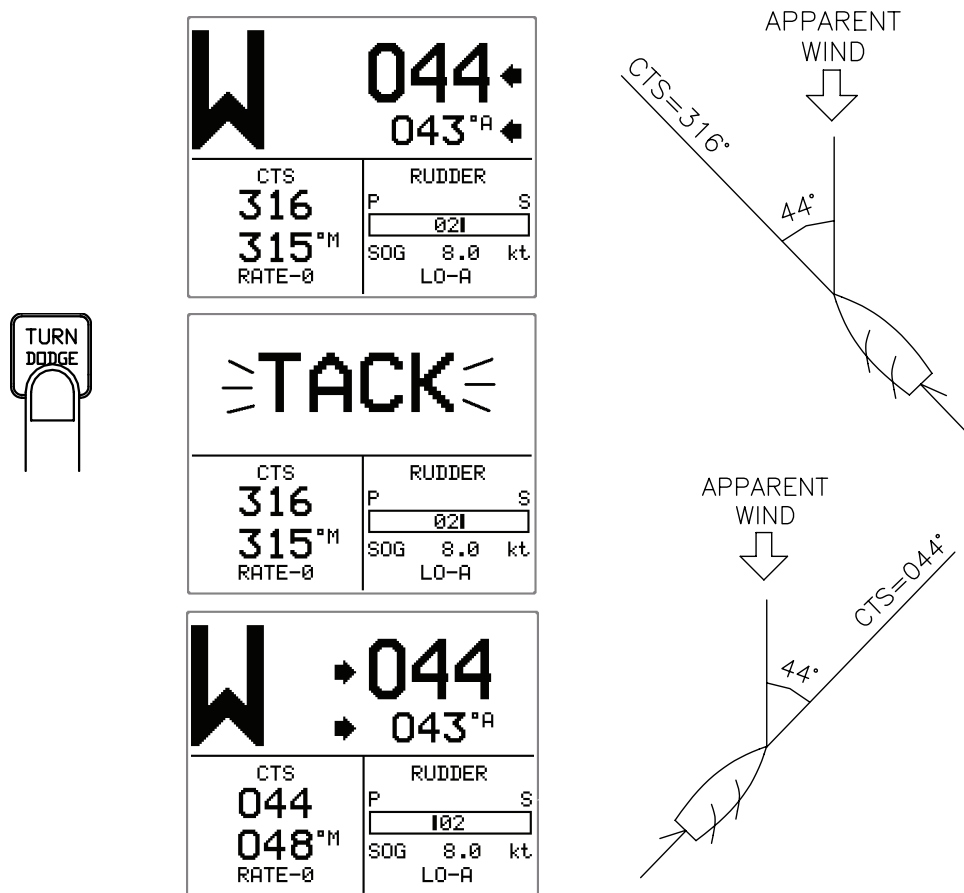

Tack and gybe operations

Gybing is possible when the true wind angle is larger than 120°.

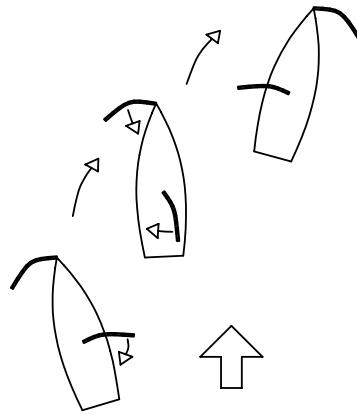
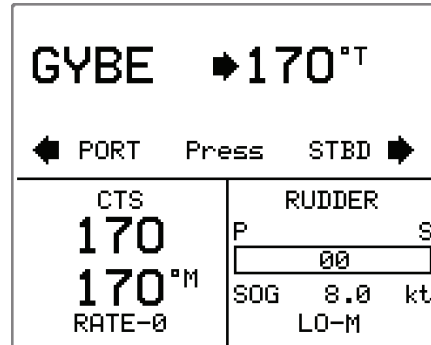

When a gybe is initiated, the wind angle will first be set to 170°T on the same side as the current wind angle. The main sail should now be hauled. With the main sail safely hauled, the wind side may be changed. This is done by pressing either **PORT** or **STBD** buttons depending on the way the boat should continue to turn. The new set wind angle will then become the same as the wind angle set before the gybe operation started.

The rate of turn when changing wind side in a gybe will be the highest possible, determined by the performance of the drive unit.

Tack and gybe prevent

When beating and running, sailing is at the most critical.

If the sails are unbalanced when beating, yaw forces from the sails can drive the boat into the wind. If the boat is driven beyond the minimum wind angle, the thrust from the sails will suddenly disappear and the boat speed reduced. Then the boat will be even more difficult to steer because the rudder will become less effective.

The tack prevent function in WIND-mode has been implemented to avoid such situations. It will react immediately when the apparent wind angle becomes 5° less than the set minimum wind angle. Additional amount of rudder will be commanded to immediately increase the wind angle.

When running, it is difficult to steer the boat with waves coming sideways or from behind. The waves may yaw the boat so that

the wind side is shifted and an unwanted gybe may happen. This can be hazardous for both the crew and the mast.

The gybe prevent function will be activated when the measured apparent wind angle becomes greater than 175° or when the wind angle gets opposite to the set wind angle. Additional rudder will be commanded to keep the wind on the same side as the set wind angle.

Caution ! *The tack and gybe prevent functions are not a guarantee against getting into a hazardous situation. If the effect of the rudder and/or drive unit is not adequate, it may happen. Pay particular attention in such situations.*

2.21 Wind steering and navigation

The autopilot can also steer the boat given both wind data and track data from a GPS/Chartplotter. In this mode called WIND_{NAV} mode the automatic steering is based on a set of criteria (see bullets below). Wind steering and navigation is activated by pressing the **NAV/WIND** button when in Wind mode. There are two sub-modes under this key: **NORMAL** (default) and **RACING** (see below). The initial course change (CHG) needed to navigate towards the active waypoint, is calculated by the autopilot. The autopilot will maintain windside in these calculations and the change of course is accepted by pressing the **PORT** or **STBD** button [1].

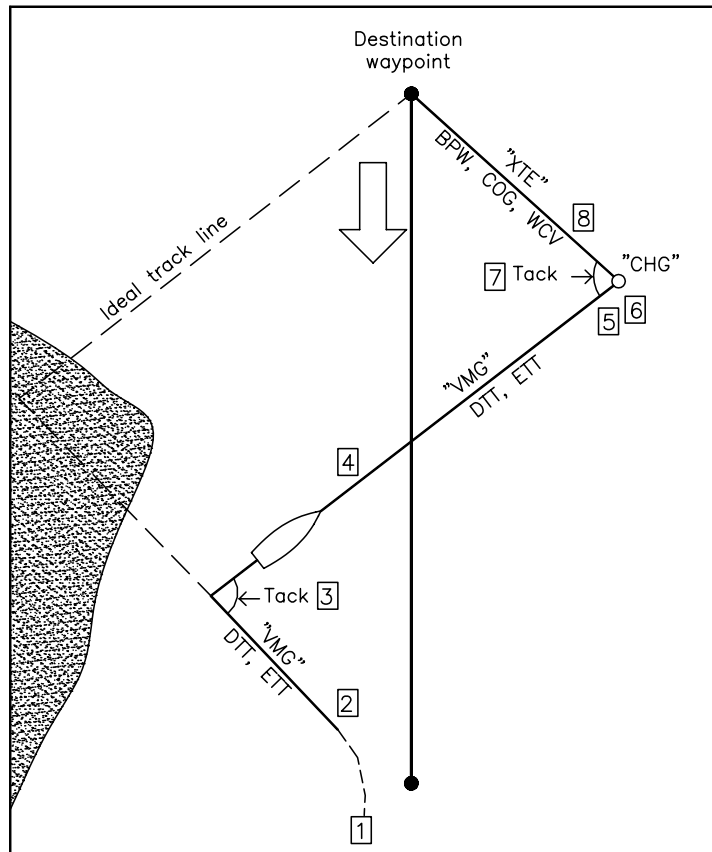
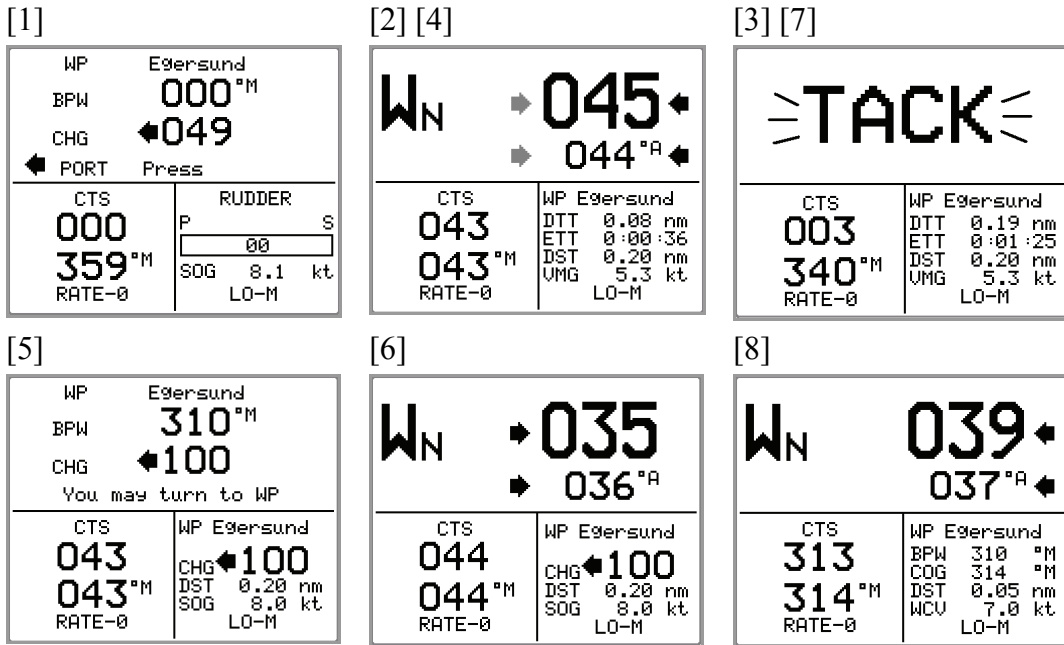

Figure 2-2 Wind steering

Operating in WIND_{NAV} mode

Refer to Figure 2-2 with references [] the associated displays and the criteria (bullets) below.

- The set wind angle should be larger than the ‘Minimum wind angle’ set in the Installation/Dockside menu and smaller than 170° Apparent.
- Information about when it is time to head directly towards the waypoint, Distance To Turn (DTT) and Estimated Time to Turn (ETT) are displayed. These calculations are based on the assumption that the set wind angle will be the same or larger after a tack or gybe towards the waypoint [3] [7].
- A turn prompt will appear when it is time to head towards the waypoint and the autopilot will calculate and display the change of heading by comparing the current heading and the heading towards the waypoint (CHG) [5].
- When heading towards the waypoint, the autopilot utilizes either the XTE from the GPS/Chartplotter to maintain track or a layline calculated by the autopilot. The calculated layline applies when the Cross Track Error (XTE) from the external navigator is larger than 0.15 nm [8].

RACING

If ‘Wind setup’ is set to ‘RACING’ in the Installation/Dockside menu, a more advanced steering is possible:

- Optimising VMG to wind may be enabled when beating and it is not possible to head directly towards the waypoint [2] [4].
- Layline steering may be disabled when heading directly towards the waypoint. Instead you can optimise the Waypoint Closure Velocity (WCV) by trimming the sails and the set wind angle. A turn prompt will then be displayed if the difference between Course Over Ground (COG) and Bearing Position Waypoint (BPW) exceeds 30° when heading towards a waypoint [8].

See chapter 2.25 Quick Setup on how to access these parameters

2.22 Multiple station system

In normal operation control is accessible from every control unit connected to the AP25 system. One control unit is "active" and provides the user with access to all functions. All remaining control units are "inactive" and have no effect on mode changes or course selection. A single press on any of the mode buttons on an "inactive" control unit will allow transfer of command and make it "active".

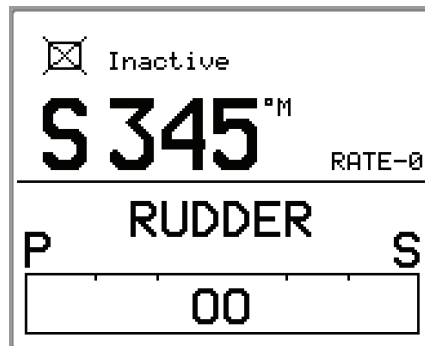



2.23 Lock function

The "LOCK" function is a safety feature in the AP25 system. It will disable all control units, including the FU25 Follow-up lever, except for a single user selected control unit location.

When the "lock" function is in use, no transfer of command can take place; only the active control unit stays in command.

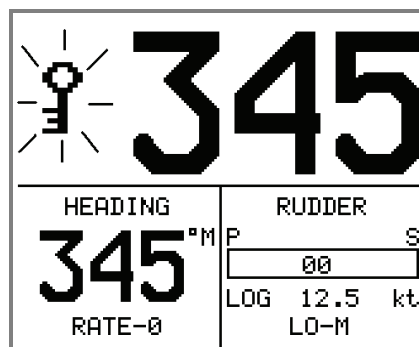
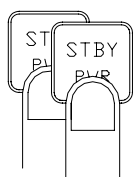
To enable the "lock" function, make a quick double press on the STBY button.



The display on the active control unit will first show a  icon and then the icon will alternate with the mode index.

The "locked" control units in the system will show:

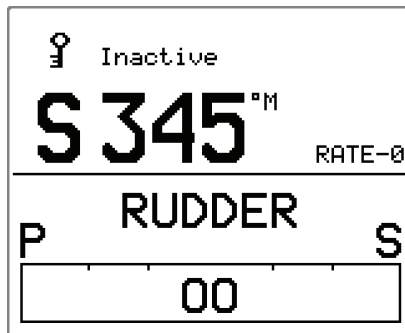

The “Lock function is disengaged by one of the following actions:

- The active control unit unlocks the other ones and makes them “inactive” by another double press on the STBY button. It also displays the  icon before it returns to the normal active state.
- The system is switched OFF by any control unit (press STBY for 2-3 seconds).

2.24 User Set-up Menu

In the AP25, all modes except NFU and FU have a complementary User Set-up menu. You can easily access the set-up menu by a quick double press on the **INFO/SETUP** button.

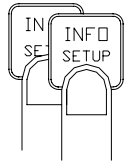

Quick double press to access

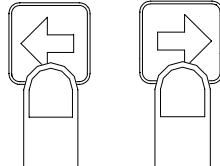

Scroll through the menu

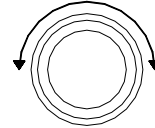

Use the course knob to change a value or a setting

Alternating Course Knob Icon



When the course knob is used in the User Set-up menu, an icon will alternate with the mode index to tell that no course changes can be made unless you press the mode button.

The user set-up menu times out 30 seconds after the last operation in the menu.

STANDBY Mode

Backlight

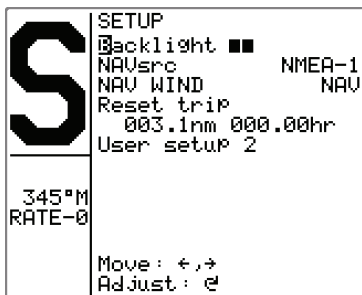

The backlight of the display and buttons may be adjusted to 10 levels (10 = brightest). The setting is stored when the system is turned off. Adjustment is local to the control unit you adjust or synchronized with other units in the Simrad Group (page 131).

NAV source

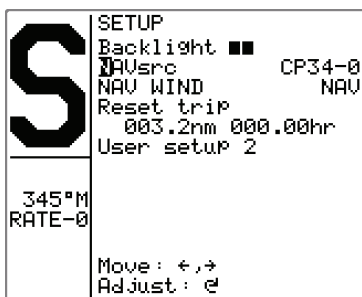

Select the source for NAV mode steering e.g. CP34.

NAV WIND

This setup will configure the active mode under the **NAV WIND** button. The following alternatives are available:

- NAV (Ref page 37)
- NoDrift (Ref. page 35)
- WIND Auto

Wind steering will be disabled when ‘NAV’ or ‘NoDrift’ is selected.

Note !

Wind steering is only available if ‘Boat type’ is set to ‘Sail’ in the Installation/Dockside menu (see Dockside settings, page 100).



If ‘NAV WIND’ is set to ‘WIND Auto’, wind steering will be enabled. Pressing the **NAV WIND** button will then initiate the WIND-mode. The autopilot will automatically select between apparent and true wind steering.

True wind steering is used when running. When the boat is running, it will also be surfing on the waves. This may lead to significant changes in boat speed, hence changes in apparent wind angle. Steering to apparent wind is therefore used only when beating or reaching.

Wind, RACING parameters

If ‘Wind setup’ is set to ‘RACING’ in the Installation/Dockside menu (see page 106), more settings are available as ‘Wind’ parameters:

- WIND Apparent
- WIND True
- WIND Auto

Default: WIND Auto

See also Quick Setup on page 59

The 'Nav/Wind' parameter can be set in the User Setup or in the Quick setup. Quick setup is activated after by quick double press on the **NAV WIND** button.

'*WIND Apparent*' is selected when you only want to steer to apparent wind. Apparent wind steering is preferred when you want to achieve maximum boat speed. The autopilot will try to maintain a constant apparent wind angle to get maximum thrust from a given trim of the sails.

'*WIND True*' is selected when you only want to steer to true wind. When sailing in closed waters, the apparent wind angle may change temporarily due to wind gusts. It may then be preferred to sail to the true wind.

Thruster

(only available if a thruster is connected as displayed by the  thruster icon).

By this parameter the thruster is turned on and off. When the thruster is turned on, both thruster and rudder are used for steering. If the boat speed exceeds 6 knots, the thruster steering is automatically disabled.

Reset trip

The trip log is reset by rotating the course knob.

User setup 2



This is a second set of user settings that normally not need to be changed during day to day use. To activate User setup 2, turn the course knob clockwise.

Source Select

Provides you with automatic or manual selection of interfaced data sources for heading (Compass), Navigation, Position, Wind Angle, Calculated Wind, Water speed, Water temperature, Distance log and Depth.

Wind-C (calculated) is a common term for true wind and wind direction.

Note ! *SimNet will automatically select Position source and Navigation source from the same GPS/Chart plotter. If you want them to be different you have to change them manually.*



Auto source update

Is used for automatically update of sources if the interfaced units have been removed/added or switched on/off.

Select Auto source update by rotating the course knob. Make sure all interfaced units are powered on

The autopilot will search for new connected sources, and replace sources no longer available.

“SEARCHING” is flashing as long as the autopilot is searching. When the automatic update is finished, the display will read “DONE”.

Press the mode button to leave the User setup.



Manual source select

Step through the list of sources using the **PORT** or **STBD** button. Select wanted source by rotating the course knob. -- indicates that no source supplying the data is available.

Notes !

1. *Simrad products will be identified by the product name provided the data is available on SimNet. If data is provided via an NMEA0183 port on the autopilot computer, the display will read NMEA-1 or NMEA-2. NMEA2000 products will have a special ID.*
2. *See note on page 88 and note 3 below.*
3. *In the event the SimNet is not powered on, sources supplying data to SimNet are not on or malfunctioning, or there is no SimNet installed, it is possible to use any control unit in the system to select NMEA sources. The source select displays are then available on all control units.*



Compass

Select the compass to be used if more than one compass is connected.

Note! *Compass can only be selected in STBY mode*

Navigation

Select a source for NAV mode steering.

Position

Select the source for position data and NoDrift mode.

Wind Apparent

Select the source for Apparent wind.

Wind Calculated

Select the source for Calculated Wind data for the Simrad group. The autopilot uses internal source irrespective of the selected source.

Water Speed

Select the source for water speed (normally the same as the source providing Log data).

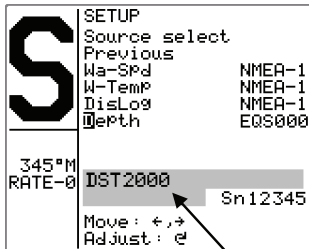

Water temperature

Select the source for water temperature (normally the same as the source providing depth data).

DisLog

Select the Log source.

Depth

Select the source for depth data.

Depth source information

Set shallow water



Use the course knob to set the shallow water alarm limit.

Range: 0-100,0 m (0-328 ft.)

The setting of the alarm is local. In a multistation system, however, the setting representing the shallowest water limit will activate the alarm even if this setting is on an “inactive” unit.

Note !

The shallow water alarm is activated only when digits are dialled in.

Course Adjust

When using the **PORT** or **STBD** buttons in AUTO mode, you are changing the set course in 1° increments. If you prefer the increments to be 10° each press (does not apply for sailboats), proceed as follows:

Select **Course adjust** and turn the course knob to change the setting. The default value is 1°, which is the preferred setting. Select 10° if you want to make major course changes in 10° increments with the buttons and fine-tune the set course with the course knob.

Turn Pattern Select

Note !

Only available for power boats (planing, displacement or outboard)

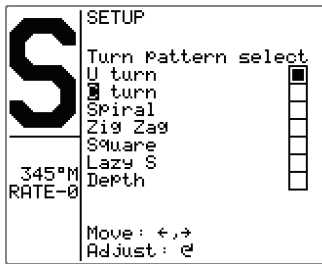

Select the pattern(s) to be available under the **TURN/DODGE** button. U-turn is always available. Step through the list of patterns using the **PORT** or **STBD** button. Select the wanted pattern by rotating the course knob to fill the squares.

Available patterns are: U-turn, C-turn, Spiral, Zigzag, Square, Lazy S, Depth (contour).

Instrument Select

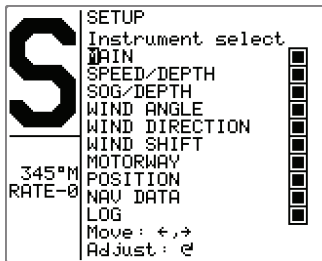

Select the instrument page(s) to be available under the **INFO/SETUP** button. Step through the list of instruments pages by using the **PORT** or **STBD** button. Select the wanted pages by rotating the course knob to fill the squares.

Contrast



The contrast of the display may be adjusted to 10 levels (10 = highest contrast). The setting is stored when the system is turned off.

Adjustment is local to the control unit you adjust. At high temperatures, not all levels are available due to automatic temperature compensation.

Press the **STBY** button to leave the User setup.

AUTO Mode

Settings that are added for the AUTO and WIND modes are shown below. Other relevant settings are described under STANDBY mode in this chapter.

Response

The Autotune function in the AP25 is so refined that 80-85 % of the boats will need no further adjustments of the steering parameters. On some boats, however, or at particular sea conditions a fine tuning of the steering parameters may improve the performance of the autopilot.

	SETUP	
	Backlight	■ ■ ■ ■
	Response	■ ■ ■ ■
	NAUsrc	NMEA-1
	NAV WIND	NAV
	Thruster	OFF
	Thruster sens	05°
	Seastate filt	AUTO
	Reset trip	
	005.1nm 000.00hr	
User setup 2		
345		
345°M		
RATE-0		
LO-M	Move: +, -	Adjust: e

The Response control allows you to make this fine tuning. It can be set to seven levels. Level 3 (default) has the values of *Rudder* and *Counter Rudder* parameters set by the Autotune function. If no Autotune is made (not recommended) the level 3 values are the factory default values.

A low response level reduces the rudder activity and provides a more “loose” steering.

A high response level increases the rudder activity and provides a more “tight” steering.

A too high response level will make the boat start S-ing.

Range: 1 – 7

Default: 3

NAV WIND setting, see page 51

Racing parameters, see page 51

Thruster sens

(only available if a thruster is connected).

	SETUP Backlight ■■ ResPonse ■■■ NAVsrc NMEA-1 NAV WIND NAV Thruster OFF Thruster sens 05° Seastate filt AUTO Reset trip 005.3nm 000.00hr User setup 2
	345 345°M RATE-0 LO-M Move: ←,→ Adjust: e

The Thruster sensitivity determines how many degrees the vessel will deviate from the set course before a thruster command is given. As the vessel deviates from its heading, the thruster will push the vessel back on. A higher value will reduce the thruster activity.

If the thruster commands are hunting from side to side, the set value for **Thruster sens** may be too low.

Range: 3° to 30° in 1° increments.

Default: 5°.

Seastate filter

	SETUP Backlight ■■ ResPonse ■■■ NAVsrc NMEA-1 NAV WIND NAV Thruster OFF Thruster sens 05° Seastate filt AUTO Reset trip 005.3nm 000.00hr User setup 2
	345 345°M RATE-0 LO-M Move: ←,→ Adjust: e

OFF: Seastate filter is disabled.

AUTO: Automatically reduces rudder activity and autopilot sensitivity in rough weather by an adaptive process (default).

MANUAL: Manual yaw band adjust (1-10, 10 ≈ ±6°).

The manual setting determines the number of degrees the vessel may deviate from the set course before any command is given to the rudder. The AUTO setting is recommended. The MANUAL settings may be used to find the optimum combination of course keeping and low rudder activity in rough but steady sea conditions.

Reset trip

Same procedure as in STANDBY mode

User setup 2

	SETUP Source select Set shallow water 011.4ft Course adjust ←→ 1° Turn Pattern select Contrast ■■■■
	345 345°M RATE-0 LO-M Move: ←,→ Adjust: e

Refer to User setup 2 for STANDBY mode, page 52.

NAV Mode

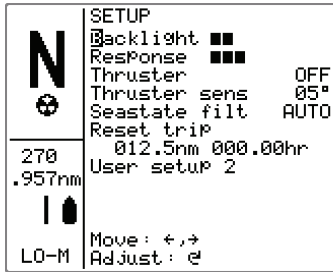

The User setup for NAV mode is similar to the User setup for AUTO mode. It does not include the Nav/Wind and the Source select items.



The User setup 2 contains the *Set shallow water* alarm and the *Contrast* setting. Refer to User Set-up for STANDBY mode.

WIND Mode

The User setup menu for WIND mode is the same as for NAV mode. In addition you have:

Wind response

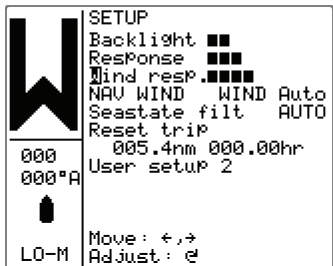

If the difference between the set wind angle and the actual wind angle is too big, the 'Wind response' can be increased to reduce the deviation.

Note !

First make sure that the course keeping is acceptable, i.e. the difference between the Course To Steer (CTS) and the actual heading is at a minimum.

If the actual wind angle is S-ing around the set wind angle or the rudder activity is too high, the 'Wind response' should be reduced.

Range: 1 – 7

Default: 3

WIND Auto

This line will only appear if the autopilot has been set up for racing in the installation menu (page 106). See page 51 for information about the RACING parameters.

User setup2

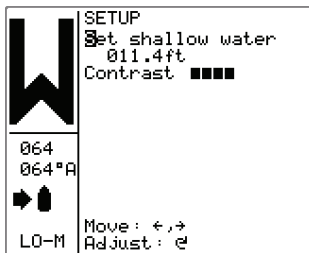

The User setup 2 contains the *Set shallow water* alarm and the *Contrast* setting. Refer to User setup 2 for STANDBY mode.

2.25 Quick Setup

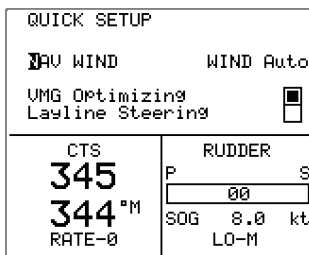

Quick Setup gives easy access to the racing parameters provided the *Wind setup* has been set to RACING in the Installation/Dockside menu (see page 106).

The Quick setup menu is activated by a quick double press on the **NAV/WIND** button.

Step through the menu by using the **PORT** or **STBD** button. Select by rotating the course knob. A filled square = On.

VMG optimizing (RACING)

The VMG (to wind) parameter can only be enabled or disabled when ‘Wind setup’ is set to ‘RACING’. It is disabled in the ‘NORMAL’ sub-mode.

When enabled, the VMG optimizing will be active for 5 – 10 minutes after a new wind angle has been set. It will only be activated when beating.

‘VMG’ will be displayed in the upper left corner under the mode index when the VMG optimizing feature is active.

Range: Enabled/Disabled

Default: Disabled

Layline steering (RACING)

‘Layline steering’ can only be enabled or disabled when ‘Wind setup’ is set to ‘RACING’. It is enabled in the ‘NORMAL’ sub-mode.

Layline steering is useful when navigating. It will use the Cross Track Error (XTE) from the navigator to keep the boat on the track line. If the XTE from the navigator exceeds 0.15 nm, the autopilot will calculate its own layline towards the waypoint and follow that. Layline steering is not active when turning, tacking or gybing.

‘XTE’ will be displayed in the upper left corner under the mode index when layline steering is active.

Range: Enabled/Disabled

Default: Enabled

2.26 INFO menu

A number of instrument pages are available under each mode screen if the required NMEA 0183 sentences are provided (see paragraph 8.1) or the information is available on SimNet (page 131). The INFO menu is accessed by a single press on the **INFO/SETUP** button.

Left hand side of the screen will show the following information depending on mode:



Standby mode
Heading
Heading source



Auto mode
Set course
Heading
Heading source
HI parameters, set automatically



Nav/NoDrift mode
Course to steer.
Cross Track error (XTE)
LO parameters set manually



Wind mode
Set true wind angle
Actual wind angle
LO parameters.

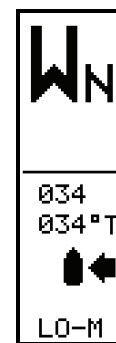

Wind_N mode
Set true wind angle
Actual wind angle
LO parameters.

Step or scroll through the available instrument screens by pressing the **PORT** or **STBD** button or using the course knob. The right hand side of the display will show the following instrument screens:

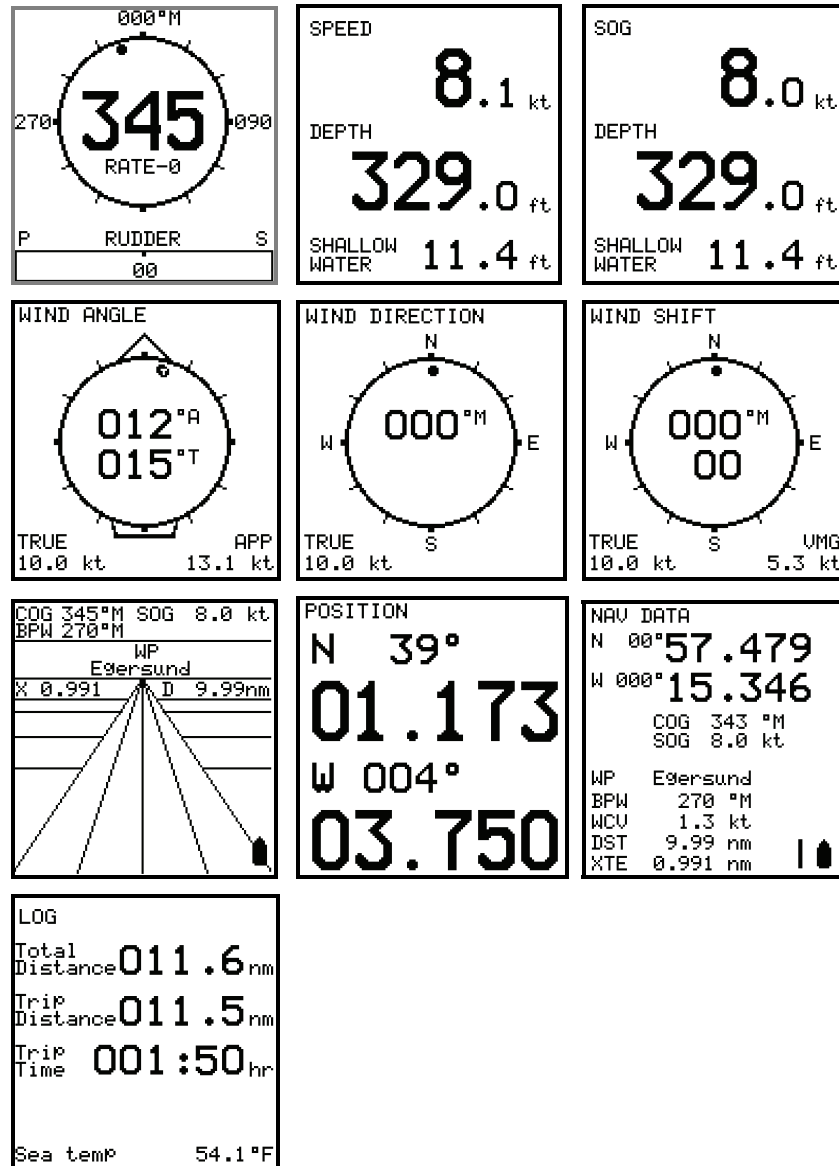

If you prefer not to have all the instrument pages available in the INFO menu, you may remove pages under the User setup 2 menu. See page 55.

Return to last instrument screen by a simple press on the INFO button.

Course knob icon



Initially when the INFO menu is accessed an icon will replace the mode index to tell that no course changes or other course related settings can be made unless you press a mode key. The icon will time out after 3-5 seconds and be replaced by the mode index.

Note !

Whenever the INFO menu is active and the mode index is present, operating the PORT and STBD button or the course knob will immediately make the main display reappear.

INFO menu flowchart

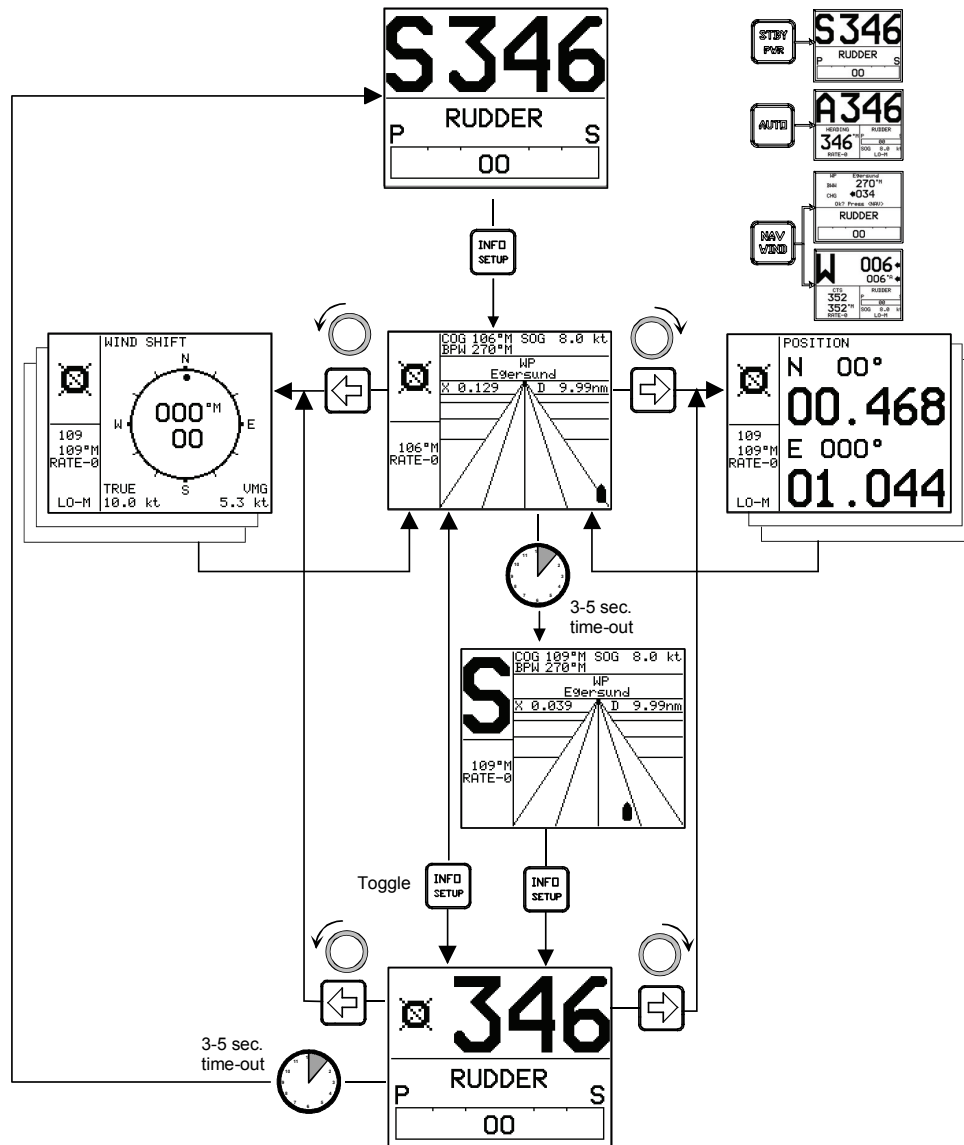

INFO menu and Main Screen, active unit

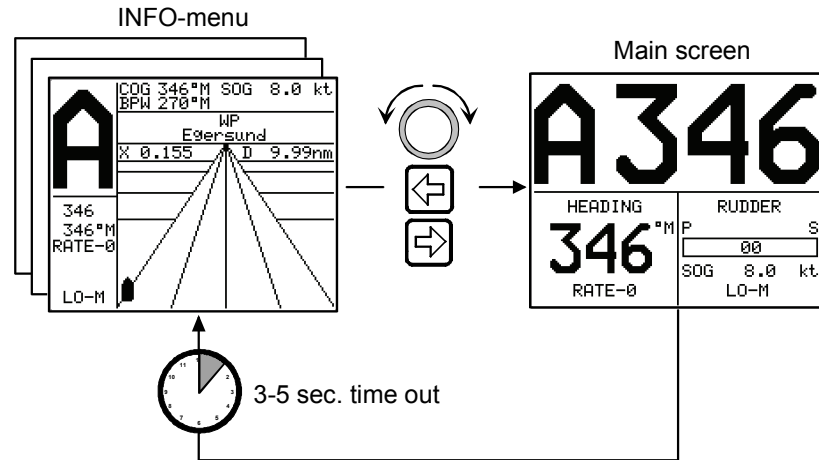

INFO menu and Main Screen, inactive or locked unit

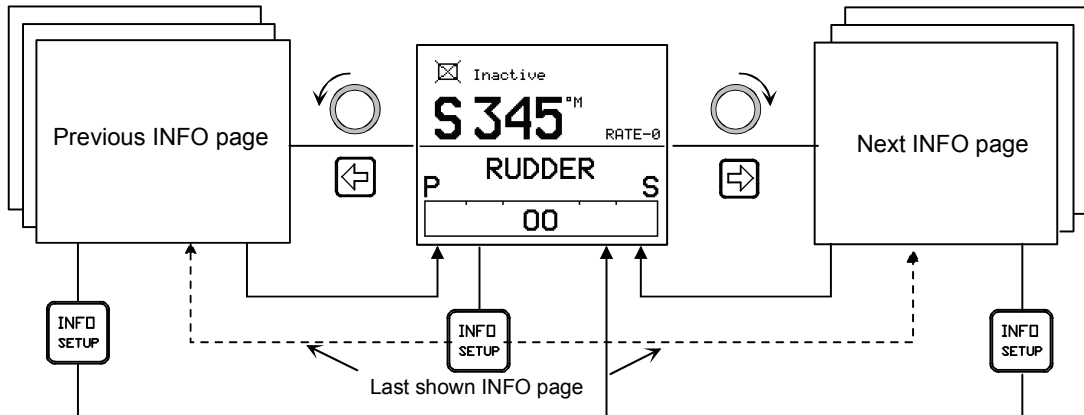

This page is intentionally left blank

3 INSTALLATION

3.1 General

This section provides detailed information required to successfully installing AP25 Autopilot system.

The AP25 system includes several modules that need to be mounted in different locations on the boat, and also need to interface with at least three different systems on the boat:

- The boat's steering system
- The boats electrical system (input power)
- Other equipment on board

In addition, the advanced capabilities of the AP25 require the installer to perform a series of settings and tests to verify proper operation of the system, refer to the check list below.

3.2 Installation checklist

1. Determine the system configuration you are installing (Figure 3-1)
2. Perform the hardware installation (Page 67)
3. Connect SimNet devices to SimNet (page 83)
4. Connect NMEA2000 devices (page 86)
5. Connect NMEA 0183 devices (inputs and outputs, page 89)
6. Perform Set-up (Section 4, page 95)
7. Perform dockside autopilot tests (refer to Operating Instructions, page 15)
 - a) Test all stations (if applicable) - lock/unlock - active/inactive
 - b) Test Non-Follow Up mode
 - c) Test Follow-Up mode
 - d) Test AUTO mode
 - e) Test NAV mode and input interfaces
 - f) Test WIND and WIND_N modes (if sailboat) and input interfaces
 - g) Test interface outputs to external equipment (if connected)
8. Perform sea trial settings (Page 114)
 - a) Rudder zero

- b) Compass calibration
 - c) Compass Offset adjustment
 - d) Automatic tuning
 - e) Viewing parameters
9. Test Autopilot Operation at Sea (refer to Sea Trial instructions, pages 114, 132)
 10. Provide the user with training (Page 133)

3.3 Unpacking and handling

Care should be taken when unpacking and handling the equipment. A visual inspection should be made to see that the equipment has not been damaged during shipment and that all components and parts are present according to the packing list.

A standard AP25 autopilot system will include:

- Control unit with standard installation accessories and one 15 m (49') Robnet2 cable.
- Autopilot computer (AC10, AC20 or AC40).
- RC36 Rate Compass with 15 m (49') cable attached.
- RF300 Feedback unit with 10 m (33') cable attached and transmission rod.
- Appropriate drive unit for the installation (unless the AP25 is going to operate an existing drive unit or solenoids).
- Optional equipment that may have been ordered for the installation.

3.4 Determine system configuration

It is important to become familiar with the configuration of the system prior to beginning the installation. The AP25 system layout with options is shown in Figure 3-1

Pay particular attention to the autopilot computer/drive unit combinations on page 72 and the chart on page 11.

As many of the units are communicating on a common network (Robnet2), with identical connectors, the installation is simplified. Try to mount the units within the standard cable length supplied with each unit, if possible. Robnet2 Extension Cable (10m) is available from your distributor.

Notes!

1. On boats powered by outboards or stern drives it may be difficult to install a rudder feedback unit (chapter 3.6 and 3.27). Use of the Virtual feedback algorithms in the software may then be preferred as this requires no installation of a rudder feedback unit (page 109). The Virtual Feedback can be used on boats up to 40 ft.
2. In order to benefit from the virtual feedback technology your autopilot system must be using a Simrad rate compass for heading information.

3.5 AP25 System Layout

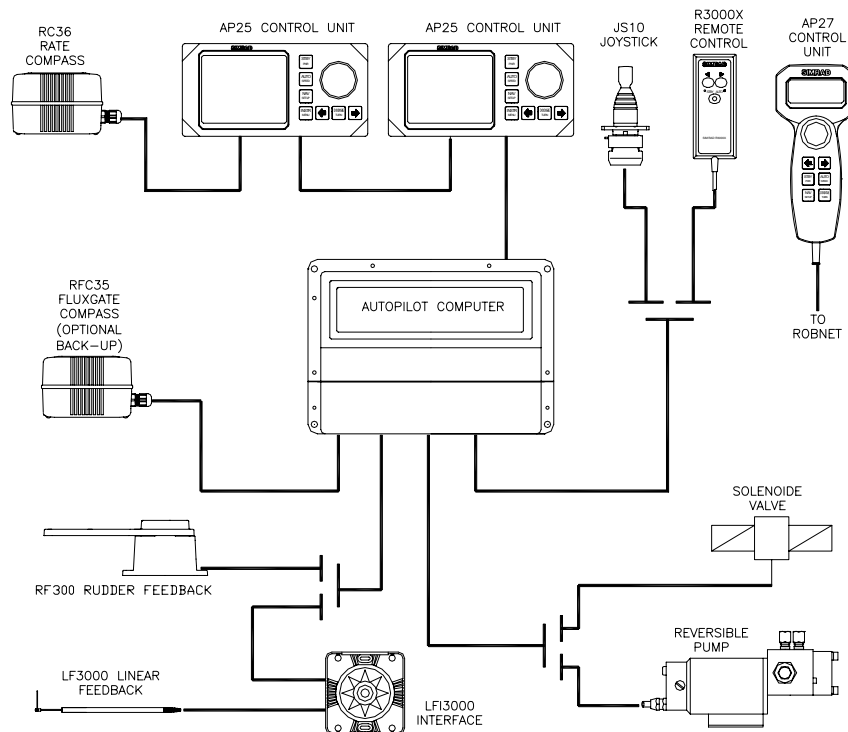

Figure 3-1 AP25 system layout with options

3.6 RF300 Rudder feedback installation

The RF300 Rudder feedback unit mounts close to the rudder, and is mechanically linked to the rudder tiller arm or rudder quadrant.

Refer to Figure 3-2 for the recommended mounting arrangement. Note that the RF300 transmitter arm has two slots for the

transmission link. The slots enable maximum flexibility to provide the 1:1 mechanical linkage relationship.

Note ! *Do not try to remove the transmitter arm from the feedback unit. The unit is factory adjusted and need no further adjustment at installation than described below.*

As a starting point, it is desirable to set the transmitter rod to the inner limit of the outer slot if possible. (Refer to Figure 3-2). Drill and tap the rudder tiller arm so that the Y1 dimension is equal to the Y2 dimension (Use 4.2 mm drill and 5 mm tap). Attach the ball joint to the tiller arm, and connect the transmitter rod to the ball joint at the rudder tiller arm.

Turn the helm wheel to set the rudder tiller arm to approximate centre position.

Rotate the RF300 transmitter lever until it is set to centre position. (Use the alignment mark to line up the transmitter lever to be opposite the cable entry into the feedback.).

Note ! *Carefully observe the alignment marks. A rudder feedback alarm may be the result if the alignment instructions as per Figure 3-2 are neglected.*

Attach the transmitter rod to the RF300. Set the RF300 mounting location to be in accordance with Figure 3-2. The centre of the RF300 should be in line with the centre of the rudder post. Mount the RF300 to a suitable platform using the screws provided. If necessary, add blocking material under the RF300 to adjust the height of the transmission arm to be level with the rudder tiller arm.

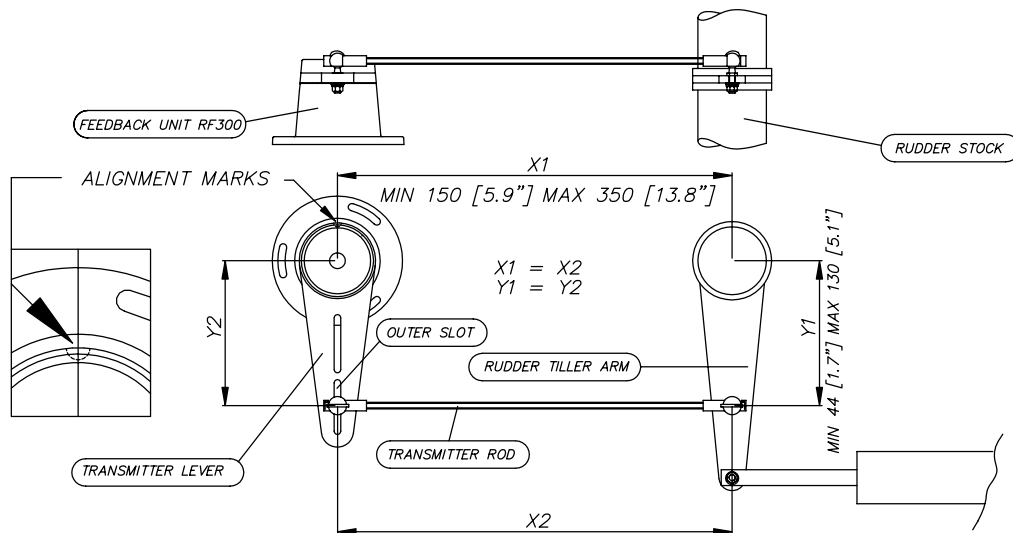

Figure 3-2 RF300 mounting (019356)

- Note !** *Due to space limitations, it may be necessary to cut the length of the transmitter rod to move the RF300 closer to the rudder post.*
- Tighten the mounting screws for both the RF300 feedback unit and the transmitter rod ball joint.
- Observe the RF300 while someone turns the helm wheel through the complete travel from full port to full stbd. rudder to verify that the mechanical linkage to the RF300 is not obstructed.

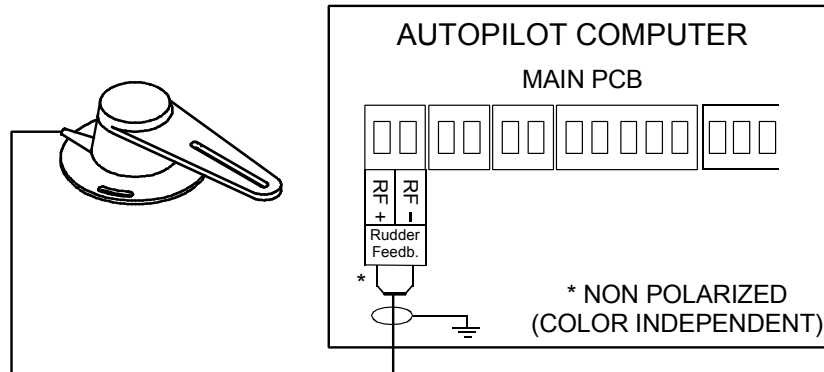

Figure 3-3 RF300 connection

3.7 Autopilot computer installation

The autopilot computer is designed to operate in a location that provides ambient temperatures below +55°C (+130°F).

- Note !** *The autopilot computer units (AC10, AC20 and AC40) are not weatherproof and should be mounted vertically as shown in a dry place between the control unit and the drive unit.*

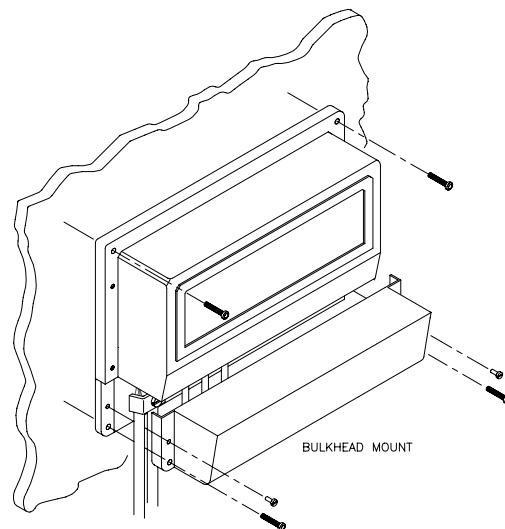

Figure 3-4 Autopilot computer mounting

3.8 Cable connections

Use only shielded cables. This includes Mains input, drive units and if necessary for the extension of the RF300 Rudder Feedback cable. The clutch/bypass cable and the solenoid cable should be 1,5 mm² (AWG14). Signal cables should be 0.5 mm² (AWG20) twisted pairs.

The mains supply cable and the drive unit motor cable should have sufficient wire gauge. This will minimize voltage drop and allow the drive unit to operate at full power.

Refer to the table below for recommended cable sizes.

Cable length	Drive Unit Voltage			
	12 V		24 V	
1. Breaker panel to autopilot computer. 2. Autopilot computer to Drive Unit motor (Length refers to each of the two cables)	AWG	mm ²	AWG	mm ²
Up to 3 m (10 ft.)	12	2,5	12	2,5
Up to 6 m (20 ft.)	10	4	10	2,5
Up to 10 m (32 ft.)	8	6	10	4
Up to 16 m (52 ft.)	6	10	8	6

3.9 Grounding and RFI

The autopilot system has excellent RFI protection and all units use the autopilot computer as a common ground/shield connection. The autopilot computer should therefore have a proper ground connection to the hull/bonding system.

Robnet2 cables and other signal cables (compass, feedback, NMEA) should not be run in parallel with other cables carrying RF or high current, such as VHF and SSB transmitters, battery chargers/ generators, winches and thrusters.

Remove the bottom cover to get access to the plug-in terminals. Strip about 1 cm (0.4") of the cable's insulation and pull the screen backwards to cover the insulation. Position the straps as shown and tighten well to make sure the screen has good contact.

Provide sufficient wire length so that the plug-in terminals can be easily connected/disconnected.

Pull out each terminal before connecting the wires. Remove all strands before putting on the terminal cover.

Note!

The Mains input is not polarity protected on AC40.

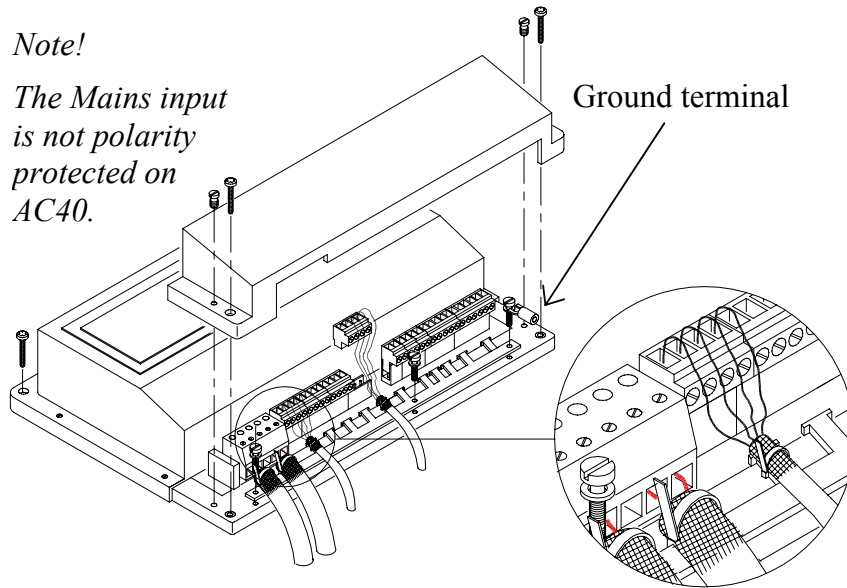

Power Board										Monitor diodes										
+ - Supply Voltage See manual		Sol.-Motor	Sol.-Motor	Sol.grnd	Drive Engage		Yel	G n	Red	Blu	Ext. alarm		Radar		NMEA Input2	NMEA Output2				
					+	-	Lamp	Stbd	Port	Gnd	+	-	Data_h	Data_c	Clk_h	Clk_c	RX2+	RX2-	TX2+	TX2-
TB1	TB2	TB3	TB4	TB5	TB6		TB7			TB8		TB9		TB10						

Power Board terminals

TB8, TB9 and TB10 are not on the AC10 Power Board

Main Board													Monitor diodes							
Rudder Feedb.		Heading Sensor		NMEA Output1		NMEA Input 1			NMEA TX		NMEA RX		Motor Inhibit		B n	W h	Pnk	Gry	Yel	
RF+	RF-	HS+	HS-	TX1+	TX1-	Vbat+	RX1+	NC	RX1-	Gnd	Bus-	Bus+	Vsys+	Vsys-	On-Off	NC	ROBNET2			
TB11	TB12	TB13		TB14			TB15													

Main Board terminals

3.10 Drive unit installation

The relations between drive units, drive unit voltage, autopilot computer, drive performance and interface to the steering gear are shown in the tables below.

Refer to the connecting diagram for the different drive units on page 74 onwards.

Installation instruction for the drive units are found in the manual for the individual units.

The maximum drive current capability of the AC10, AC20 and AC40 autopilot computers are different. Use the table below as reference and observe the notes on next page.

HYDRAULIC PUMPS

MODEL	MOTOR VOLTS	AUTOPILOT COMPUTER	RAM CAPACITY		FLOW RATE AT 10 bar cm ³ /min (cu. in./min)	MAX PRESSURE bar	PWR. CONSUMPTION
			MIN cm ³ (cu. in.)	MAX cm ³ (cu. in.)			
RPU80	12V	AC10	80 (4,9)	250 (15,2)	800 (49)	50	2,5-6 A
RPU160	12V	AC20	160 (9,8)	550 (33,5)	1600 (98)	60	3-10 A
RPU300	12V	AC40	290 (17,7)	960 (58,5)	3000 (183)	60	5-25 A
RPU300	24V	AC20	290 (17,7)	960 (58,5)	3000 (183)	60	2,5-12 A

Steering gear interface: Hydraulic plumbing

Notes !

1. *The AP25 system detects whether a reversible motor or a solenoid is connected and outputs the correct drive signal automatically.*
2. *The drive output of AC10 is sufficient for any type of 12 and 24V solenoids normally found on a recreational boat.*

LINEAR DRIVE UNITS

MODEL	MOTOR VOLTS	AUTO-PILOT COMPUTER	MAX STROKE mm (in.)	PEAK THRUST kg (lb.)	MAX RUDDER TORQUE Nm (lb.in.)	HARD-OVER TIME sec. (30% load)	PWR. CON-SUMP.	TILLER ARM mm (in.)
MLD200	12V	AC10	300 (11,8)	200 (440)	490 (4350)	15	1,5-6 A	263 (10,4)
HLD350	12V	AC10	200 (7,9)	350 (770)	610 (5400)	12	2,5-8 A	175 (6,9)
HLD2000L	12V	AC20	340 (13,4)	500 (1100)	1460 (12850)	19	3-10 A	298 (11,7)
HLD2000D	24V	AC20	200 (7,9)	1050 (2310)	1800 (15900)	11	3-10 A	175 (6,9)
HLD2000LD	24V	AC20	340 (13,4)	1050 (2310)	3180 (28000)	19	3-10 A	298 (11,7)
MSD50*	12V	AC10	190 (7,5)	60 (132)	–	15	0,8-2 A	–

Steering gear interface: Connects to quadrant or tiller.

* For stern drive power assisted steering only.

1. *The motor voltage is stepped down by the autopilot computer when operating from 24V or 32V mains.*
2. *The specified autopilot computer is necessary to achieve max drive unit capacity.*
3. *Recommended operational thrust or torque is 70% of listed peak value.*
4. *Typical average power consumption is 40% of listed maximum value.*

PREVIOUS MODELS DRIVE OF UNITS

Model	Autopilot computer	Drive unit voltage	Input voltage (Mains)	Drive output	Interface to steering gear
RPU100 (1,0l) RPU150 (1,5l) RPU200 (2,0l) (Reversible hydraulic pump)	AC20	12V 12V 24V	12,24,32V	Proportional rate	Hydraulic plumbing
RPU1 (1,4/2,0l) RPU3 (3,8/5,0l)	AC10 AC10	12V, 24V 24V, 24V		Solenoid valves, on/off	Hydraulic plumbing
MRD100 (Reversible mechanical drive)	AC40 AC20	12V 24V	12,24,32V 24,32V	12V to clutch 24V to clutch Proportional rate to motor	Chain/sprockets
MRD150 (USA only)	AC20	12V 32V	12, 24V 32V	12V to clutch 32V to clutch Proportional rate to motor	Chain/sprocket

Note ! *When selecting **DRIVE UNIT** voltage in the Installation setup, the clutch/bypass voltage is always set equal to the motor voltage. If a retrofit installation where e.g. a HLD2000 has a 12V motor and a 24V bypass valve, the bypass valve solenoid has to be changed back to standard 12V version.*

Connecting a reversible pump

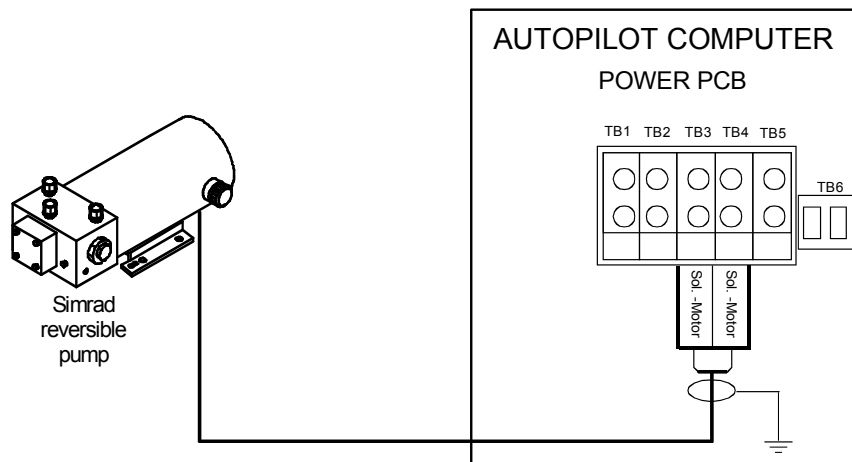

Figure 3-5 Connecting a reversible pump

Connecting a hydraulic linear drive

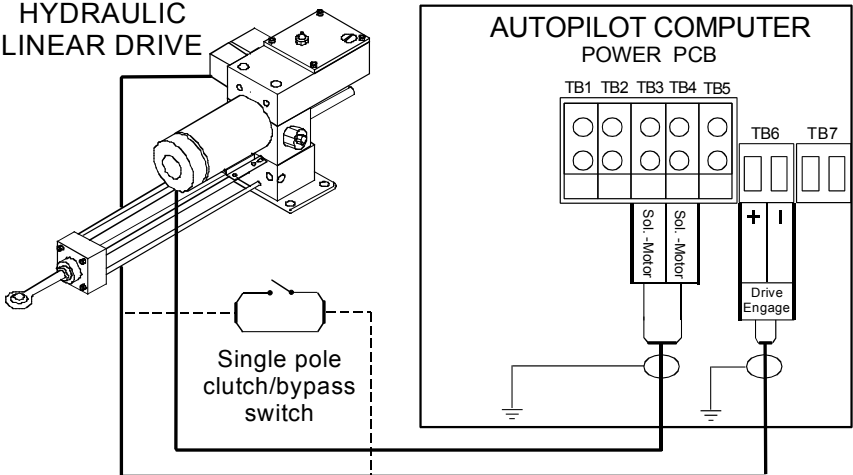

Figure 3-6 Connecting a hydraulic linear drive

Connecting a solenoid valve

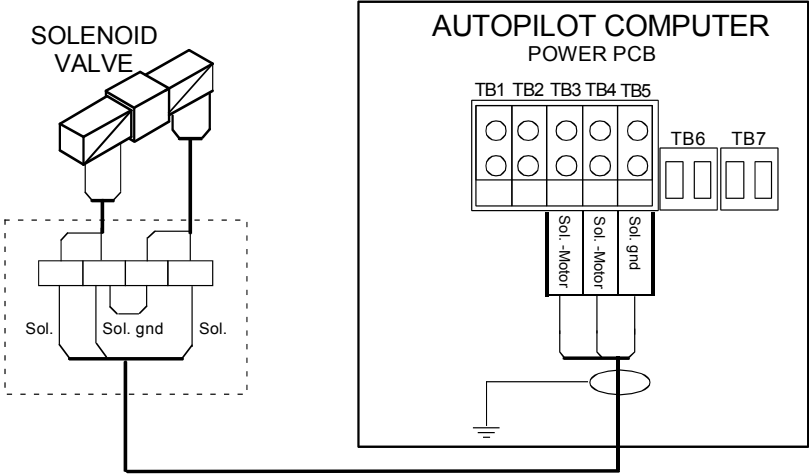

Figure 3-7 Connecting a solenoid valve

3.11 Control unit installation

Avoid mounting the control unit(s) where it is easily exposed to sunlight, as this will shorten the lifetime of the display. If this is not possible, make sure the units are always covered with the white protection cover when not used.

Caution ! *Do not install the control unit where moisture at the rear can be present. It could cause damage by entering the breathing hole or by coming into contact with the electrical connectors.*

Panel mounting

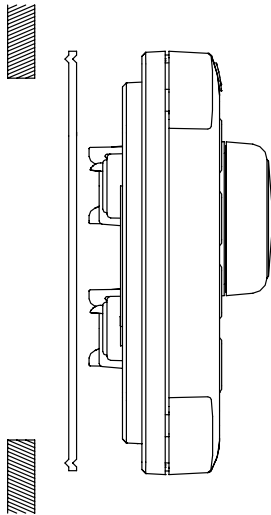

The mounting surface must be flat and even to within 0.5 mm.

- Drill the 4 mounting holes and make a panel cut-out according to supplied template.
- Use the supplied gasket (P.N. 22084693) between the panel and the unit.
- Use the supplied 19 mm screws to fasten the control unit to the panel.
- Apply the front panel corners.
- Connect the Robnet2 cable(s) to the control unit connector(s).

Alternative panel mounting

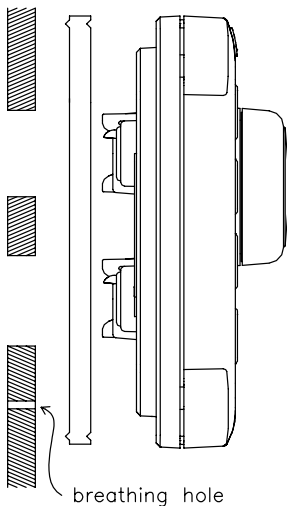

This way of mounting may be simpler, but will lift the unit from the panel surface. When installed adjacent to Simrad equipment there will be a 5,5 mm (0,22") difference in height between the autopilot and the other equipment.

- Use the template and drill hole(s) only for the connectors.
- Place the thick gasket (P.N. 22086029) between panel and unit, correctly orientated (see marking on gasket).
- Follow above panel mounting instructions but use the supplied 32 mm screws to fasten the control unit to the panel

Do not over-tighten the mounting screws!

Optional bracket mounting

- Locate the cradle on the mounting site and mark the 4 holes for the fixing screws on the mounting surface.
- Drill the 4 mounting holes and screw the cradle to the mounting surface.
- Use the supplied screws to fasten the control unit to the left and right brackets.
- Apply the front panel corners.
- Use the two locking knobs to assemble the cradle with the left and right brackets and adjust the control head to best viewing angle.
- Connect the Robnet2 cable(s) to the control unit connector(s) (See note on page 78).

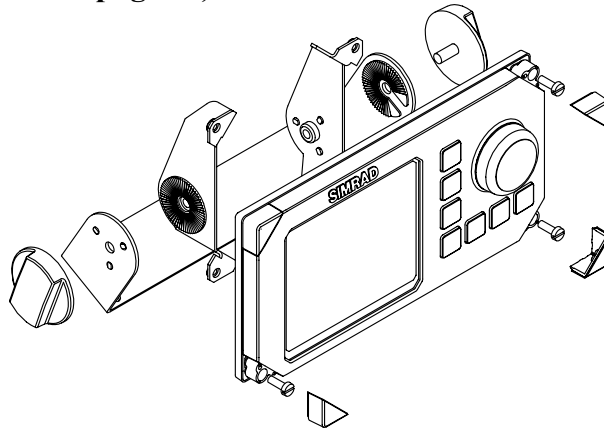

Figure 3-8 AP25 Bracket mounting

3.12 ROBNET2 network cables

As Robnet2 units have two Robnet2 connectors (blue) they can be used as "jack points" for further expansion of the system. There are no dedicated "in" or "out" connectors. You may connect the cables to any available Robnet2 connector (blue) on the specific unit. The Robnet2 connectors have a locking mechanism for extra safety.

Caution !

Do not mix the blue Robnet2 cables with the yellow SimNet cables.

The 15 m cable to the autopilot computer has a connector only at the control unit end. Robnet2 cables with 5 pin male connector at

both ends are available in 1, 5 and 10 m length. For cable extension a Robnet2 T-Joiner is required.

When installing a system, try to minimize total Robnet2 cable length by connecting all Robnet2 units to the nearest available Robnet2 connector.

Total length of Robnet2 cable installed in a system should not exceed 50 m (165').

Examples of interconnecting Robnet2 units:

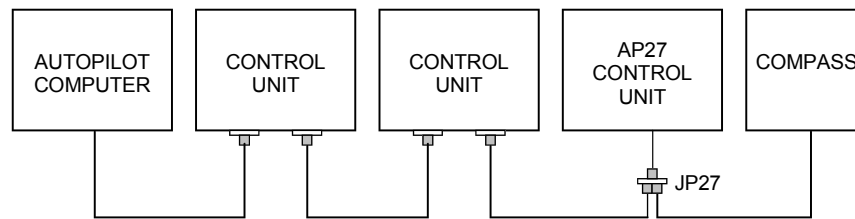

Figure 3-9 Interconnecting Robnet2 units

A Robnet2 T-joiner P/N 24005662 is available to make the Robnet2 interconnection more simple by reducing the number of cables or extend cables when necessary.

See table for pin configuration and colour code of the network cable.

Cable pairs	Color code	Signal
1. pair	Pink	V SYSTEM+
	Grey	V SYSTEM-
2. pair	Brown	Bus-
	White	Bus+
	Yellow	On - Off

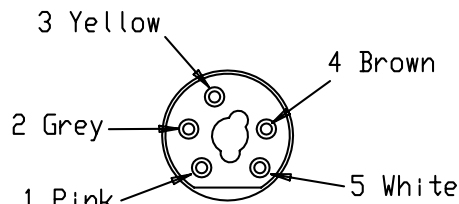

Figure 3-10 Robnet2 Connector

Note !

The connectors are weather proof according to IP65, when properly installed. All connectors not in use must be fitted with the plastic cap to protect them against dirt and moisture.

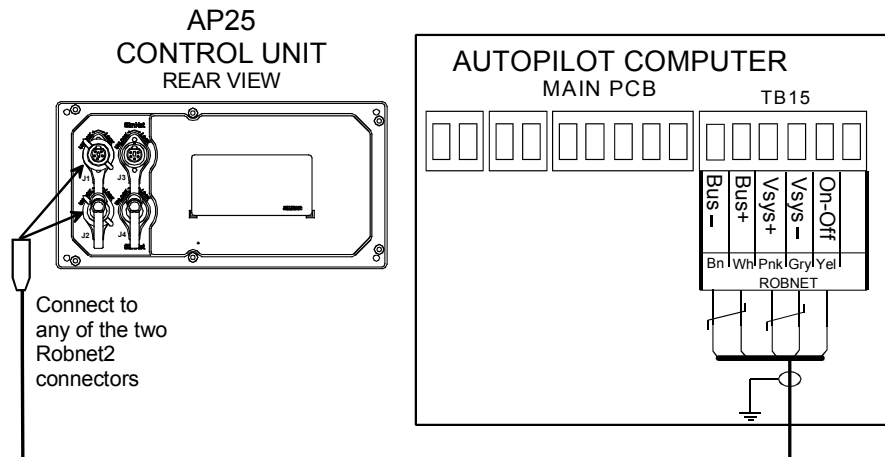

Figure 3-11 Control unit connection

J1 and J2 (top) are Robnet2 connectors. J3 and J4 are SimNet connectors.

AP27 connection

If a Simrad AP27 is part of the system, use the JP27 Jack Point and connect as shown on Figure 3-9. Alternatively cut the connector from the cable and connect the wires in parallel with the cable shown on Figure 3-11 using the same color code.

Note !

The AP27 cable contains an air-breathing tube. Check that the tube is open after you have cut the cable.

3.13 RC36 Rate Compass installation

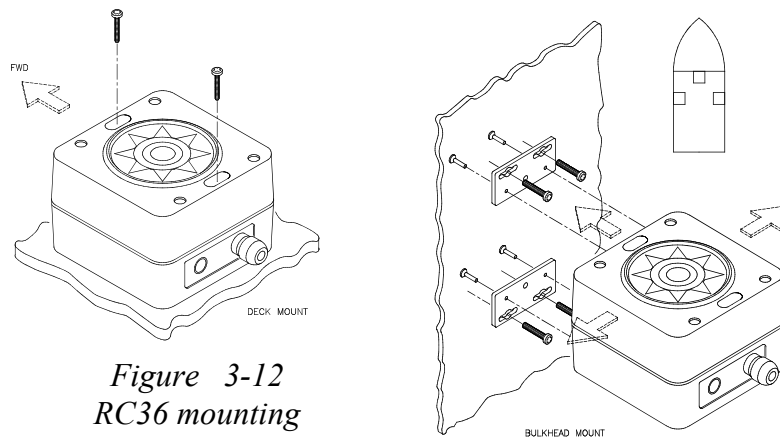

Figure 3-12 RC36 mounting

The heading sensor is the most important part of the AP25 system and great care should be taken when deciding the

mounting location. As the heading is displayed on the AP25 Control Unit, the heading sensor can be mounted at a remote location.

The RC36 rate compass also contains a magnetic heading sensor, so particular attention must be paid to the location. It can be mounted on deck or bulkhead, athwartship or alongship and has a 15 m (99') cable with a Robnet2 connector. The heading offset feature in the AP25 will compensate for the mechanical offsets that may be a result of the selected location and orientation of the RC36.

If the RC36 is deck or bulkhead mounted athwartship with the cable gland pointing aft, little if any offset correction is required. With the cable gland pointing forward a 180° correction is required.

When mounting RC36 on a bulkhead alongship, a +90° or -90° correction is needed dependent on whether it is port or starboard bulkhead.

Note !

Offset correction is performed after the calibration (see paragraph 4.7).

Find a location that provides a solid mounting place free from vibration, and as close to the vessel's centre of roll and pitch as possible, i.e. close to the water line. It should be as far as possible from disturbing magnetic influences such as the engines (min. 2 meters), engine ignition cables, other large metal objects and particularly the drive unit. On steel hull boats it should be mounted 0,75-1 m above the wheel house on a non magnetic stand.

Use the supplied mounting kit and drill the holes through the centre of the slots in the sensor or the mounting brackets.

Note !

The compass face plate on the RC36 is the TOP. Never mount it upside down! Level the sensor as close to horizontal as possible.

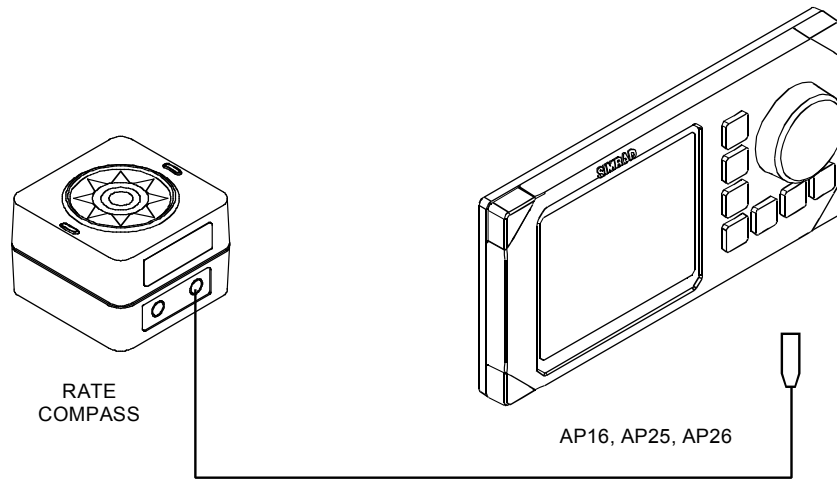

Figure 3-13 RC36 connection to autopilot control unit

Plug the RC36 into a Robnet2 connector (see Figure 3-9) or cut the connector from the cable and connect the wires in parallel with the cable shown in Figure 3-11.

3.14 RFC35 Fluxgate Compass installation

(Optional back-up compass)

The RFC35 Fluxgate Compass is a magnetic sensor, which means you have to take the same precautions at installation as for the standard RC36 (see previous page).

- Connect the RFC35 to the autopilot computer as per Figure 3-14

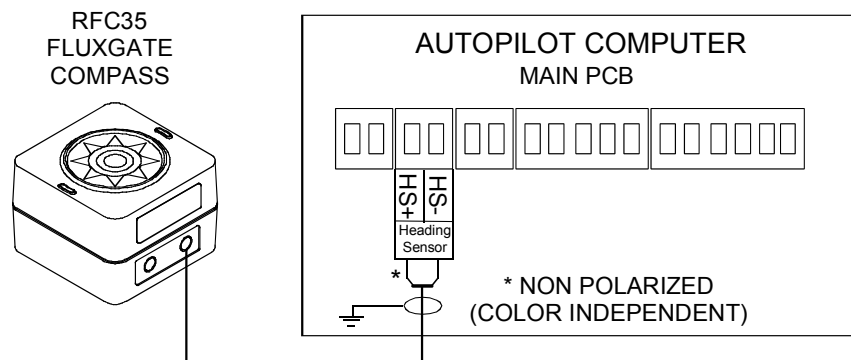

Figure 3-14 RFC35 connection

3.15 R3000X Remote Control installation

R3000X should be mounted in the supplied bracket that can be fixed by four mounting screws. The unit is weather proof and can be mounted outdoor.

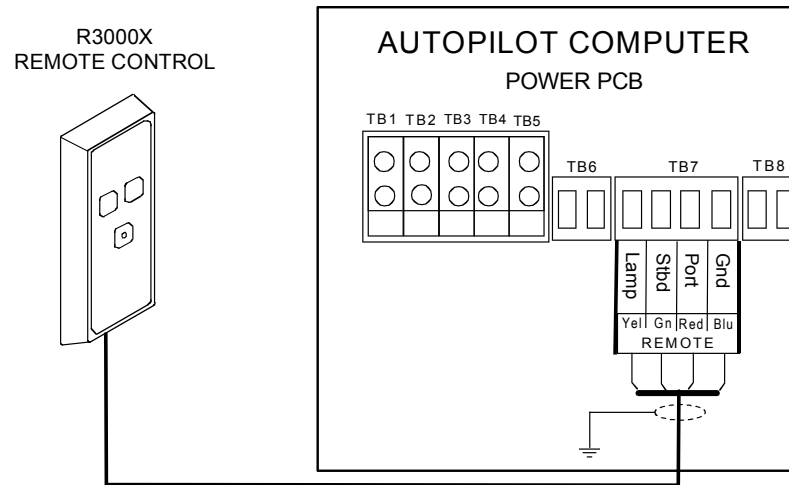

Figure 3-15 R3000X connection

3.16 JS10 Joystick

Refer to separate installation instructions supplied with the JS10 Joystick.

3.17 S35 NFU Lever installation

The unit is mounted to a bulkhead or panel by two screws from the front. The cable is connected to the autopilot computer according to Figure 3-16. Interchange the Port and Stbd wires to the screw terminals if necessary to make the direction of the lever movement coincide with the direction of the rudder movement.

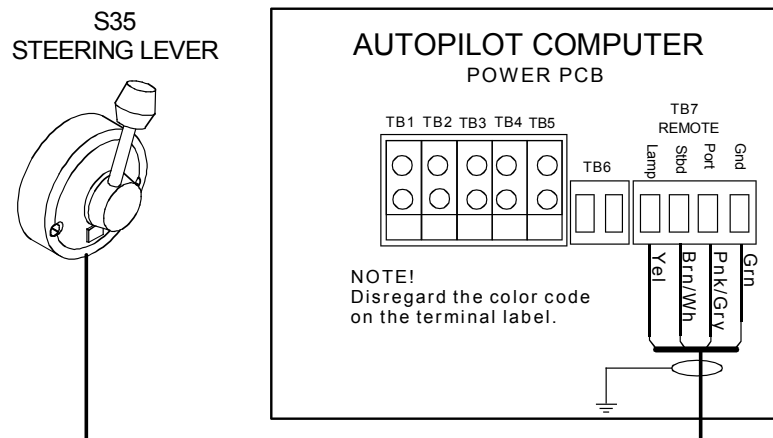

Figure 3-16 S35 connection

The unit is opened by removing the three screws on the back cover. Inside are two sets of micro-switches, a printed circuit board with a plug-in terminal and a jumper strap.

3.18 Interfacing

With the AP25 autopilot system there are several possibilities to connect to other equipment for data collection and exchange.

1. Use SimNet
2. Use SimNet via AT10 Universal SimNet/NMEA Converter
3. Connect to a NMEA2000 network via the adapter (drop) cable, part no. 24005729.
4. The AC10 has a single NMEA0183 input/output port.
5. The AC20 and AC40 have two NMEA0183 input/output ports and Clock Data interface to Simrad and Furuno radars.

The NMEA0183 output may also drive Simrad IS15 instruments directly.

The different connecting diagrams on the following pages illustrate the interface possibilities of the AP25 autopilot.

3.19 SimNet

The SimNet cable system with very small plugs in both ends makes it easy to run the cables, only 10 mm (3/8") holes are required through panels and bulkheads. The SimNet accessory program contains the necessary items to complete a successful installation.

SimNet network cables

A SimNet unit has one or two yellow SimNet connectors. There are no dedicated “in” or “out” connectors. Find the shortest and easiest way to route the SimNet cables from product to product and select the standard length cables from the SimNet accessory program. SimNet cables are available in 0.3 m (1 ft.), 2 m (6.6 ft.), 5 m (16.6 ft.) and 10 m (33 ft.) length all with plugs at both ends. Connect products with two SimNet connectors in a daisy chain and use drop cable and T-joiner for products with only one SimNet connector.

The SimNet power cable has a red connector with built in terminator.

If you plan to extend your SimNet system in the future it may be an idea to prepare for it by adding a few T-joiners in central locations. The T-joiners provides easy access to the network and can be replaced with a new product, or the new product can be connected via a drop cable.

SimNet power and termination

The following rules should be observed when installing SimNet.

1. It must have a separate 12VDC power from the battery bus or the circuit breaker board to avoid interference
2. It must not be connected to the supply voltage terminals of the Autopilot Computer (introduces interference).
3. It will power an IS12 instrument system. Hence SimNet on other equipment can be connected and powered via IS12.
4. It must be properly terminated.

The SimNet network has to be terminated according to the number and type of products connected.

In a small system consisting of maximum 5 SimNet products and a total length of 5 m SimNet cable you only need the SimNet power cable with built in termination (red disc on cable plug). On larger systems you will also need a termination at the other end of the chain.

For additional information about SimNet ask for the separate SimNet Manual.

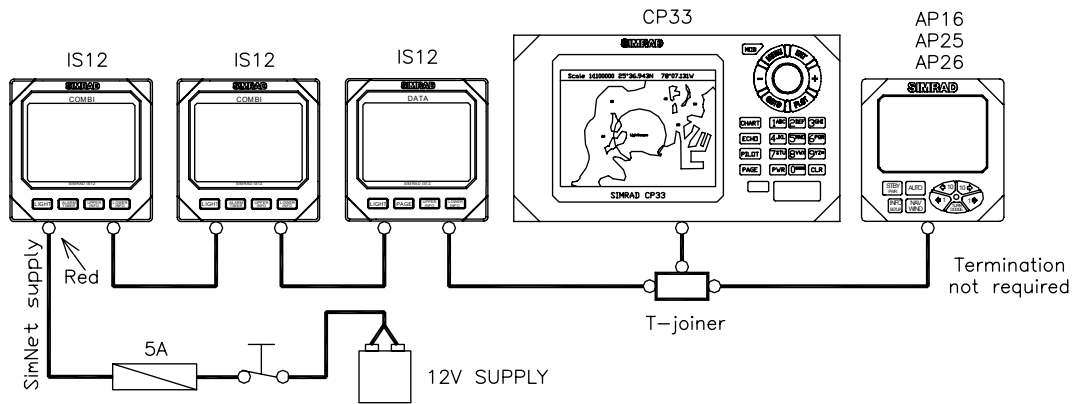

Figure 3-17 SimNet network, small system

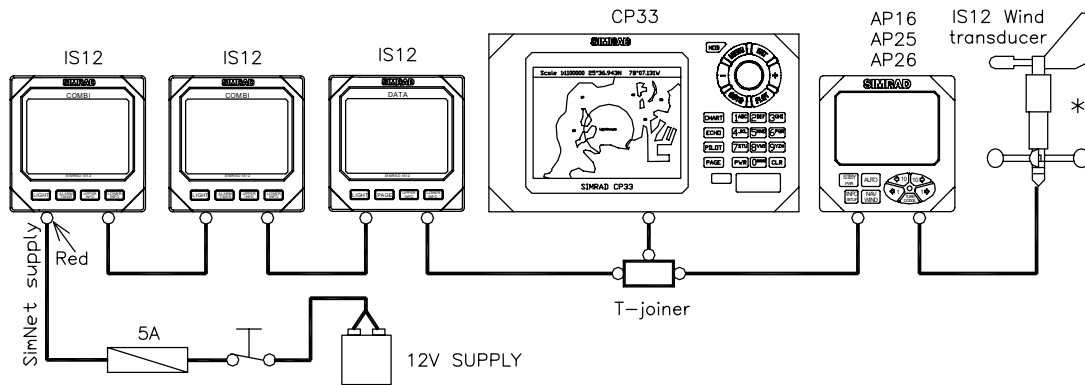

Figure 3-18 SimNet network, small system with Wind transducer

The wind transducer (*) has a built in terminator.

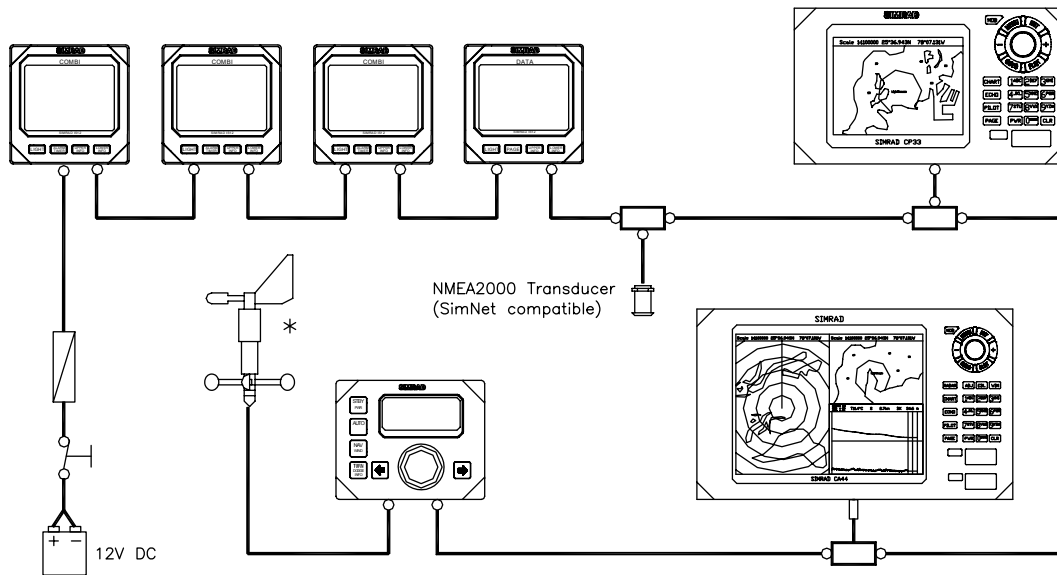

Figure 3-19 SimNet network, medium system

Notes !

1. Maximum total length of SimNet cable is 40 m (130 ft.) excluding the 30 m (99 ft.) of masthead cable.
2. The wind transducer (*) has a built in terminator
3. If there is no wind transducer connected, a SimNet terminator must be connected instead.

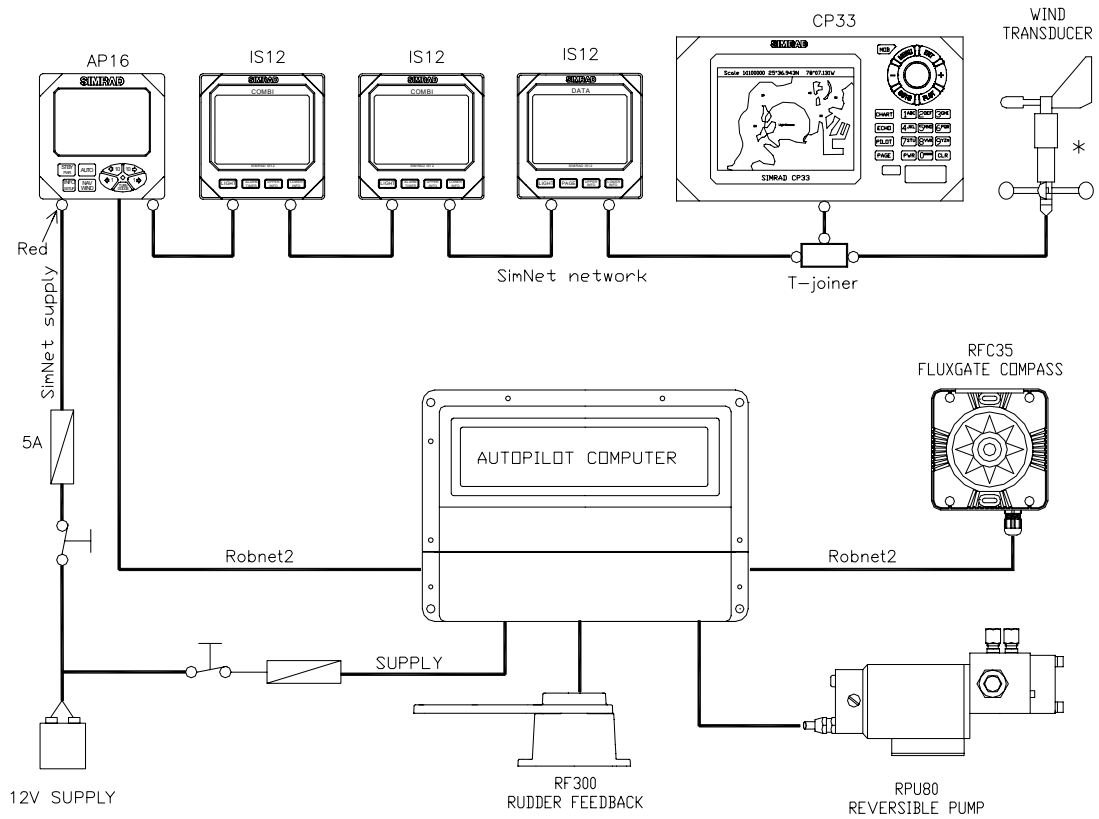

Figure 3-20 Robnet2 and SimNet network

* The wind transducer has a built in terminator

Simrad AP25 Autopilot

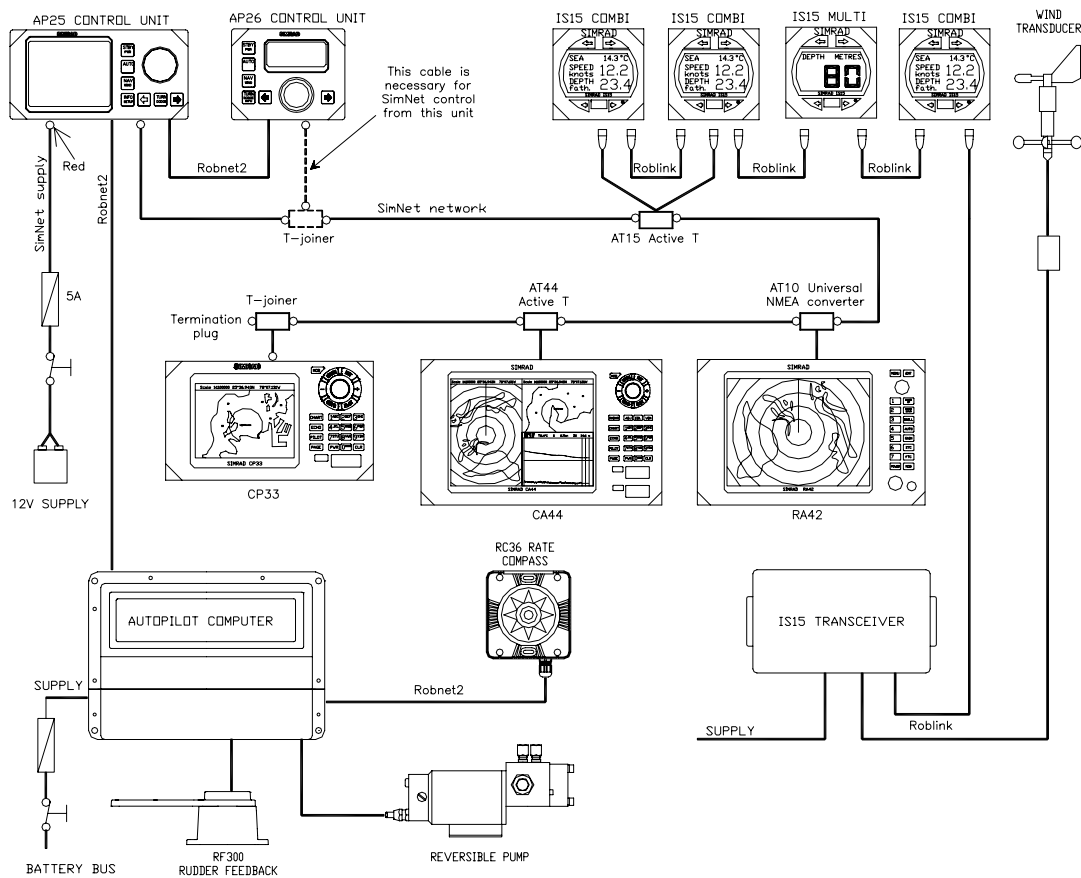

Figure 3-21 Robnet2, SimNet and Roblink network

Notes !

1. Maximum total length of SimNet cable is 60 m (196 ft.) excluding the 30 m (99 ft.) of masthead cable.
2. It is not necessary to connect all autopilot control units to SimNet for data sharing. However, if you want to have full redundancy and SimNet control, e.g. select sources, you have to connect the actual unit to SimNet.
3. AT15 is a NMEA0183/SimNet converter for the IS15 Instrument system. IS15 makes no load on SimNet.
4. AT44 is a SimNet interface that is supplied with CX44 and CX54 products.

3.20 Single NMEA input/output

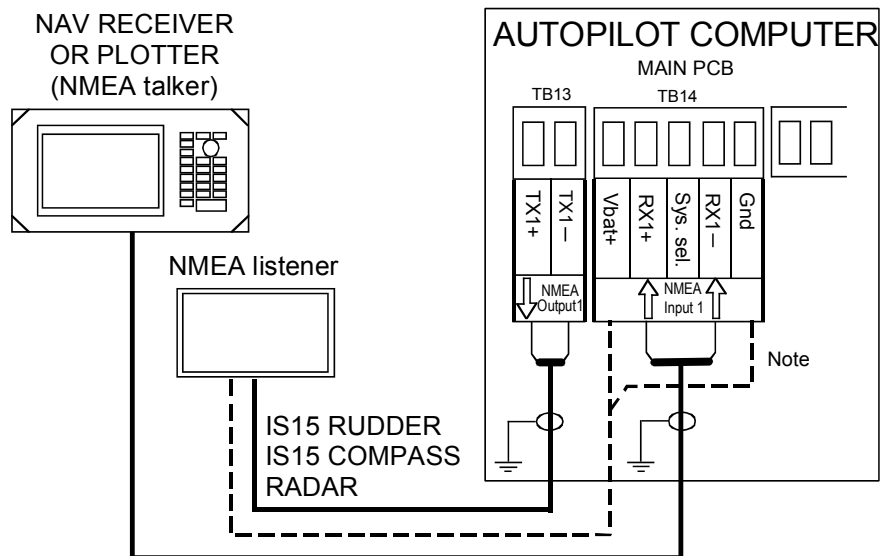

Figure 3-22 Single NMEA connection

Caution ! *If an IS15 Instrument is powered from TB14 Vbat+ and Gnd, please observe that Vbat output voltage will follow mains supply voltage. IS15 Compass can only operate on 12V.*

3.21 Double NMEA input/output

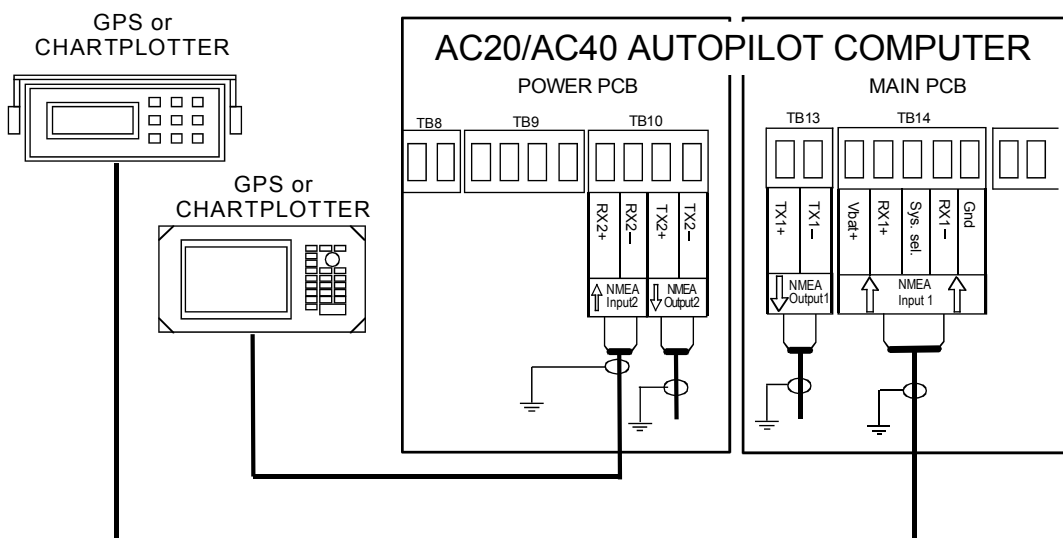

Figure 3-23 Double NMEA connection

3.22 NMEA output on Port 2

Output signal	Output terminal	Output sentence
Continuous output of compass heading at 10 Hz (10x/sec.) Rudder angle output at 5 Hz NMEA format	Autopilot Computer Power PCB. NMEA2, TX2+, TX2-.	HDT (True) or HDG (Magn.) depending on heading source. RSA Rudder angle

3.23 NMEA Compass input

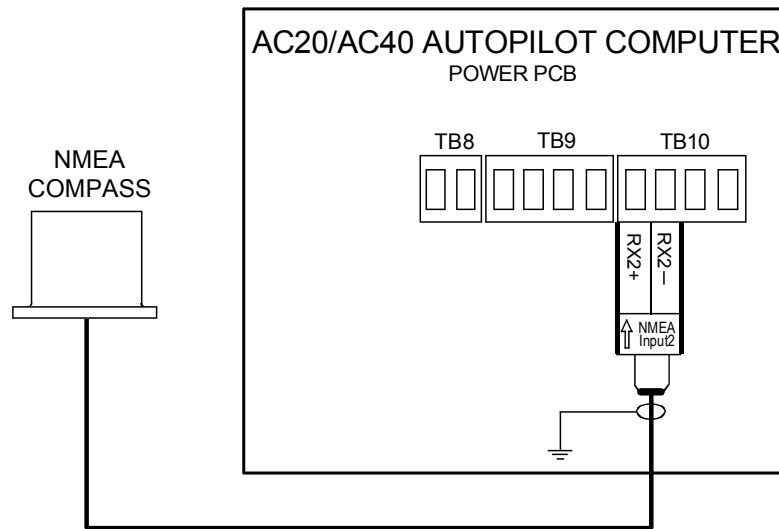
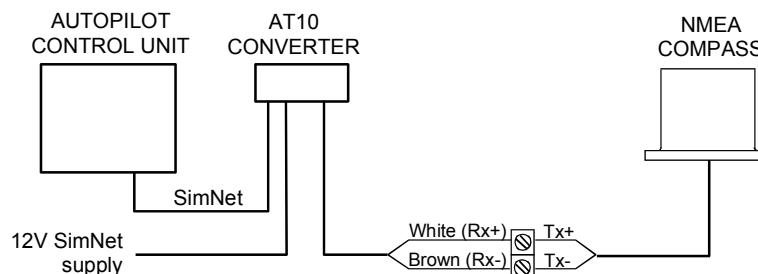

Figure 3-24 NMEA compass connection:

Notes !

1. The compass connected to the NMEA port (RX2) will not be calibrated from the autopilot.
2. The AC10 Autopilot Computer has no port for NMEA compass input. Use the AT10 Universal Converter (P/N 24005936) according to the drawing below.



3.24 Radar Clock/Data

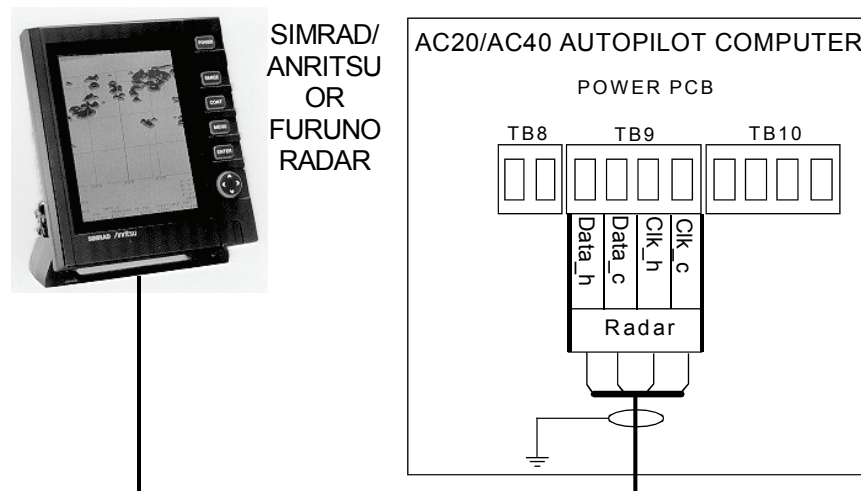

Figure 3-25 Radar Clock/Data connection

3.25 IS15 Instrument installation

For installation and operation of the IS15 instruments refer to separate manuals. There are two options for interfacing the IS15, SimNet (see page 83) and NMEA0183. The SimNet interface is recommended and you need the dedicated AT15 Active Tee as an interface item (page 88, 146).

NMEA In

This connection will provide speed, depth and temperature input to the autopilot. If an IS15 Wind Transducer is connected to the system, wind information will also be transferred to the autopilot.

The connection is made by a Roblink cable from the instrument NMEA socket (4) to the Autopilot Computer Main Board, Terminal RX1+ and RX1-. See Figure 3-26.

NMEA Out

This will provide the instrument system with heading data.

The connection is made by a Roblink cable from the Autopilot Computer Main Board, terminal TX1+ and TX1- to the instrument NMEA socket (4). See Figure 3-26.

You will need a minimum of two instrument heads to make the system both 'listen' and 'talk' (I/O).

If IS15 Expander is used in the instrument system, the NMEA connections are made to this unit. See Figure 3-27.

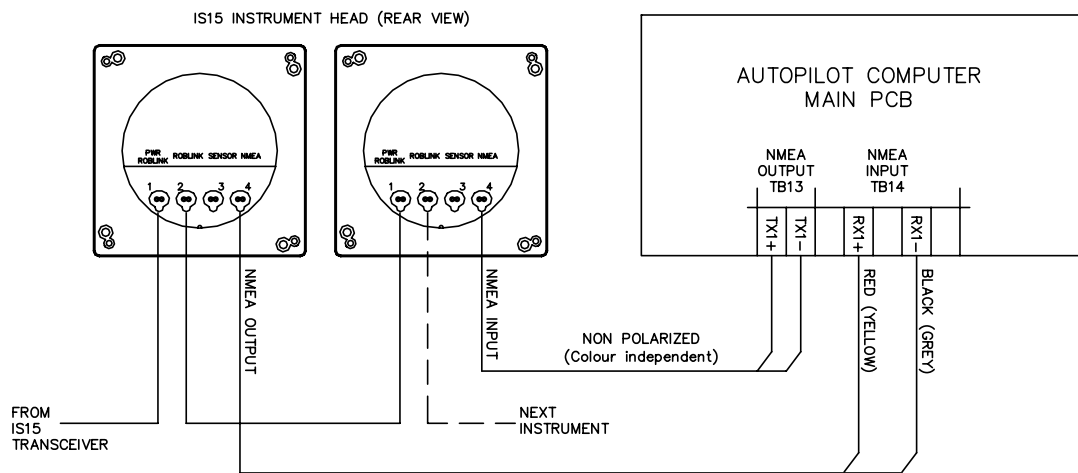

Figure 3-26 IS15 Instruments / Autopilot computer connection

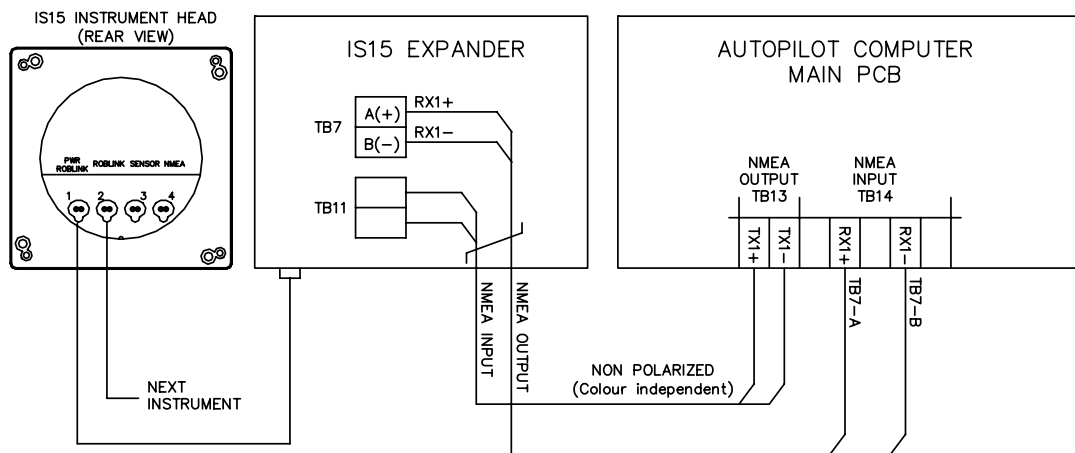

Figure 3-27 IS15 Expander / Autopilot computer connection

3.26 External Alarm

The external alarm circuit has an open collector output for an external alarm relay or buzzer (not on AC10). The operating voltage for the circuit is the main supply voltage. Max. load on external alarm output is 0.9 Amp.

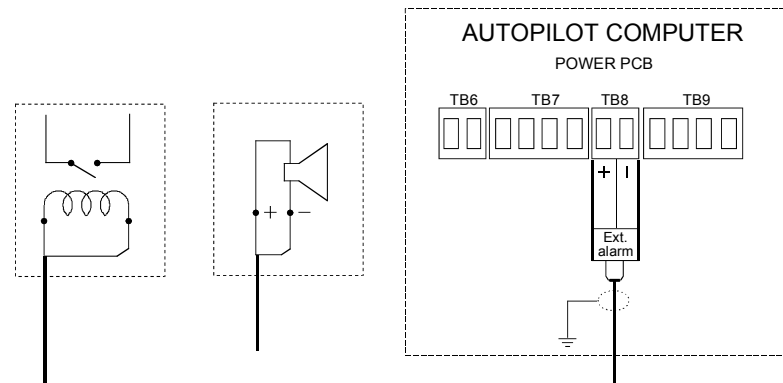

Figure 3-28 External alarm connection

3.27 LF3000 Linear Feedback

Caution ! *The rod of the LF3000 is not locked in place in the cylinder. Pay attention as it may slip out of its housing and end up on the seabed.*

The LF3000 is a waterproof feedback unit. It has a 300 mm (11,8") stroke and comes with a special mounting bracket which secures the LF3000 to the cylinder of the existing outboard drive unit.

The 8,5 m (28') cable is terminated in the LFI3000 Mk2 Linear Feedback Interface according to Figure 3-30.

The mounting hardware provided is made to interface with Teleflex HC5340 cylinders and Hynautic K7 and K10 Cylinders. The hardware may not be appropriate for other systems.

Center the drives. Loosely secure the LF3000 to the supplied mounting bracket, across the center of the drive unit cylinder. Either cylinder may be used if there is a dual set up. You may mount the feedback in either direction, i.e. the shaft of LF3000 may point to port or starboard.

Loosen the end bolt (a) used to secure the cylinder to the drive unit mount. Insert the rod retaining assembly (b) and retighten the bolt. Secure the feedback rod to the retainer plate using the

two washers and the cap nut provided. Adjust the location of the LF3000 Linear Feedback to allow full travel of the hydraulic cylinder without causing the retainer plate to hit the end of the cylinder. Check that the outboard motor can be tilted freely. Tighten all nuts and the mounting bracket.

Turn the helm slowly by hand to the stop on either side, check that the rod does not bind up in any direction. Make a “drip nose” (c) on the cable to the unit and clamp the cable to allow full engine movement to port and starboard.

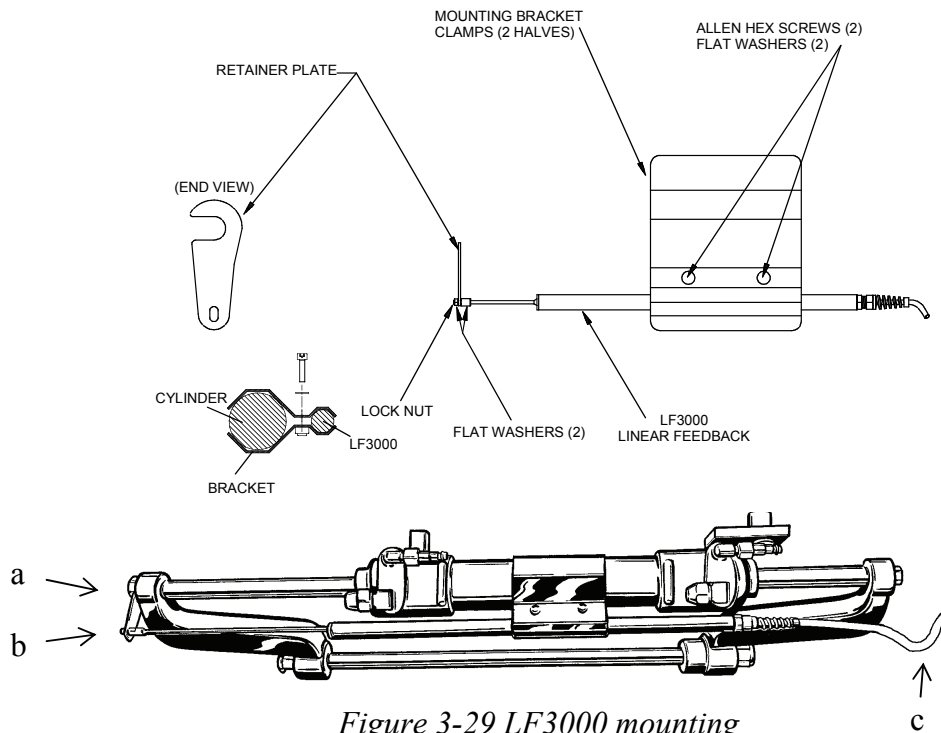

Figure 3-29 LF3000 mounting

Electrical connection

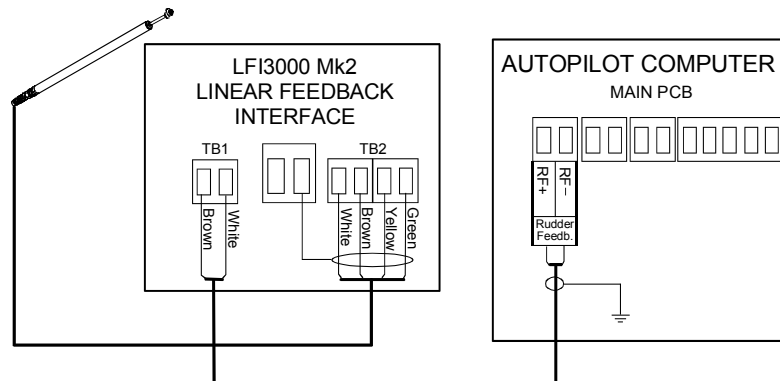

Figure 3-30 LF3000/LFI3000 Mk2 connections

4 CONFIGURATION AND SETUP

4.1 First time turn on

Before attempting to turn on the AP25 and perform an Installation Setup, the hardware installation and electrical connections must be completed in accordance with the installation instructions.

The design of the AP25 includes advanced features that have simplified the installation and setup of an autopilot.

Note !

If the autopilot is going to use Virtual feedback (page 67) you must first go to page 109.

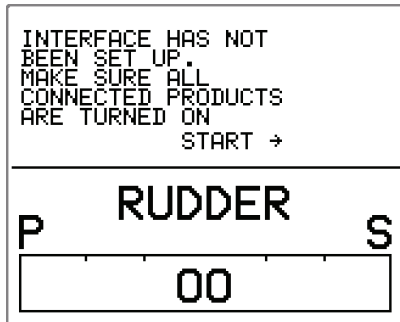

This is the start-up screen that is presented the first time you turn on your autopilot by pressing the **STBY/PWR** button.

Notes !

1. You can postpone the automatic interface by going directly to the Installation/Dockside setup. Any time the STBY button is pressed the interface prompt will reappear until the automatic interface has been performed.
2. Be aware that you will have no compass reading before the automatic interface is completed.

Continue by pressing the **STBD** (START) button to start the automatic interface.

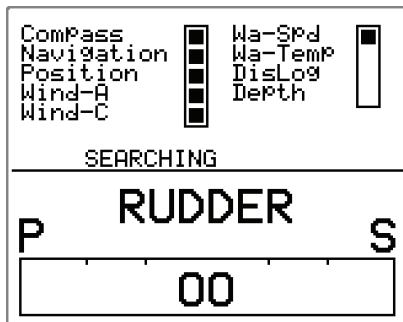

The autopilot will search for connected sources, and as the sources are detected a black square appears on the screen.

“SEARCHING” is flashing as long as the autopilot is searching for data.

When the automatic interface setup is finished, “FINISHED PRESS →” is displayed. Press the STBD button to accept.

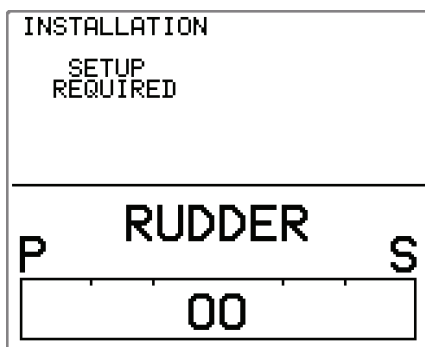

The display will read 'SETUP REQUIRED'.

Continue with the installation setup according to the next chapters.

If you already have completed the installation settings, the autopilot will enter STBY mode.

4.2 Description of Installation Settings

Note !

The installation settings must be performed as part of the installation of the AP25 system. Failure to do so correctly may prohibit the AP25 from functioning properly!

The Installation menu can only be accessed in STBY mode.

The Installation Settings are grouped into the following functional categories:

- Language: Selection of language used for display information
- Dockside: Items to be set prior to sea trials
These will vary depending on the type of feedback the autopilot will use (page 67, 100, 109)
- Interface: Setting the format of the clock/data output for radars connected to the Autopilot Computer.
- Display units: Setting the units to be displayed for wind speed, water temperature and depth.
- Sea trial: Presents settings and automatic calibrations to be performed during sea trial.
- Parameters: Permits viewing and changing of basic steering parameters (See also Response control, page 56).
- Service: System data, NMEA data, NMEA test, SimNet setup, Master reset of memories.

Each group is designed to focus on specific functions, and enable quick access when changes need to be made.

Some important points regarding the installation settings:

- When the AP25 is delivered new from the factory AND ANY TIME AFTER A MASTER RESET OF MEMORIES HAS BEEN PERFORMED, the installation settings are all reset to factory preset (default) values. The automatic interface prompt will appear (see page 95) and a complete setup has to be made.
- The values that are selected from within the Installation Settings Menu, are stored in the memory of the AP25 system. No specific action is required to "SAVE" the selected values. Once the value is changed, it is stored until the next time the menu item is selected and changed.
- The Installation Settings are global except for display units and language, enabling settings to be distributed to all control units in the system.
- The Seatrial settings are dependent on successful completion of the Dockside settings.

4.3 Installation Menu



The Installation Menu is presented on the autopilot display by pressing and holding the **INFO/SETUP** button for 5 seconds.

Note !

The INSTALLATION MENU is different from the USER SETUP MENU. Refer to the flow diagram on the next page for a pictorial view of the Installation Menu.

Navigate through the Installation Menu as follows:

- Answer YES to a question by rotating the course knob clockwise.
- Answer NO to a question or proceed to the next menu item by pressing the **STBD** button.
- Return to the previous menu item by pressing the **PORT** button.

- Change the selected item by rotating the course knob in either direction.
- Exit the Installation Menu by pressing **STBY**, **AUTO**, or **NAV/WIND** buttons.

When using the Installation Menu, refer to the diagram "Installation settings Menu Flow Chart" on next page.

Note !

*You may proceed through all items in the installation menu by continuing pressing the **STBD** button.*

Language selection

To access the language selection in the Installation Menu, confirm "Yes" by turning the course knob clockwise

The AP25 can present the display text in eight different languages:

English, Deutsch, Francais, Espanol, Italiano, Nederlands, Svenska and Norsk.



Turn the course knob to select the language you wish to use.

Continue to next item in the menu by pressing the **STBD** button, or leave the menu by pressing the **STBY** button.

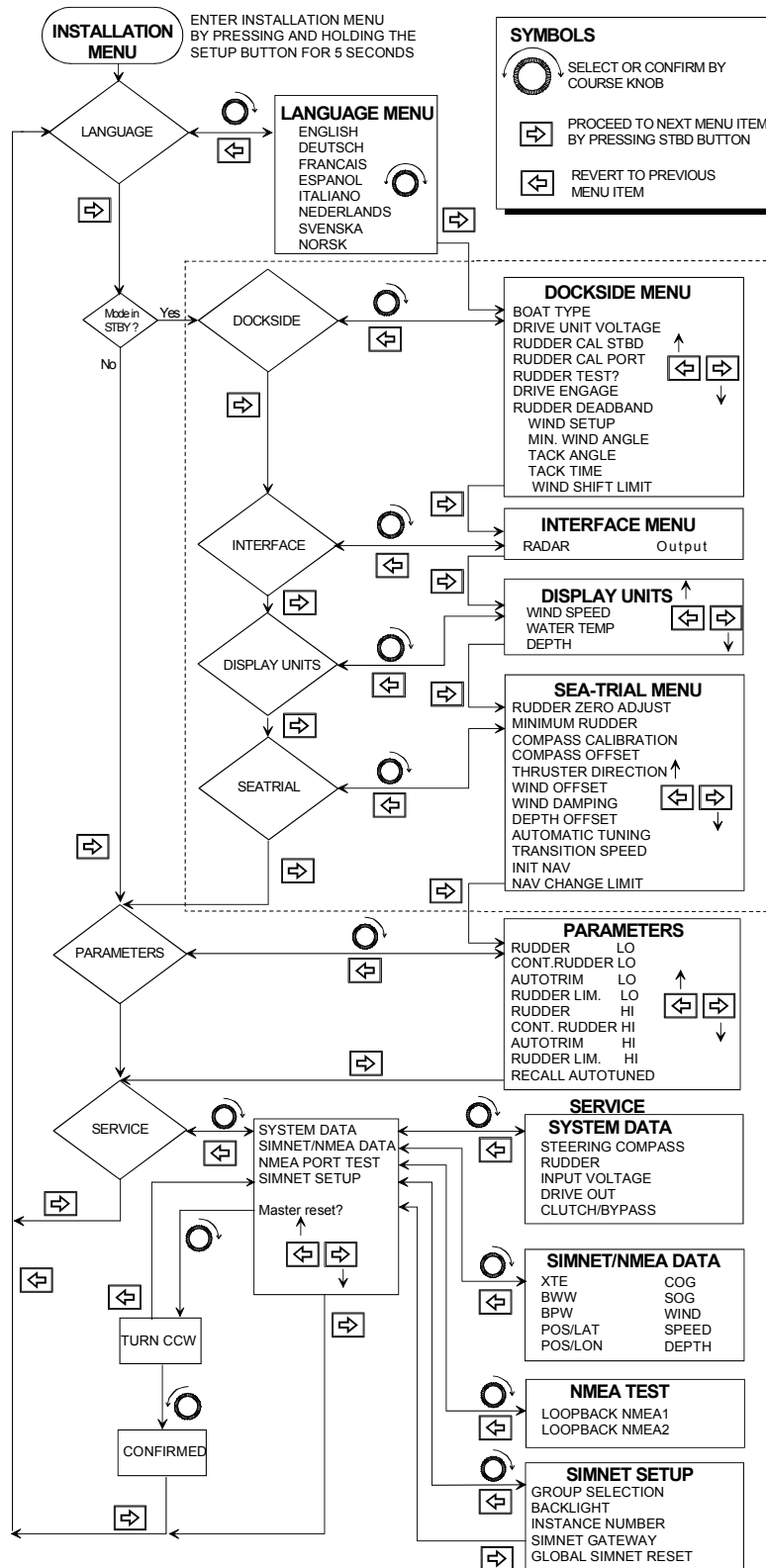

Figure 4-1 Installation Menu Flow Chart

4.4 Dockside settings

Note ! *If the autopilot has no rudder feedback unit installed (configured for Virtual feedback), refer to the Dockside settings on page 109-112.*

The following menu items are accessible and can be set up in the Dockside Menu:

- Boat type
- Drive Unit voltage
- Rudder Feedback calibration
- Rudder test
- Motor drive output
- Drive engage
- Rudder deadband

When Sail is selected as Boat type the following menu items are also accessible in the Dockside Menu:

- Wind setup
- Min. wind angle

If Wind setup is set to RACING the following items are added to the menu.

- Separate (port, stbd) wind angle limits
- Tack angle
- Tack time
- Wind shift limit

Select STANDBY mode and enter the Installation Menu as previously described. Select *Dockside* by pressing **STBD** button and confirm by rotating the course knob clockwise.

Boat type

```

INSTALLATION
  Dockside
→ Boat type      Sail
  Drive unit voltage  --U
  Rudd feedb cal STBD  --°
  Rudd feedb cal PORT  --°
  Rudder test        ----
  ---- drive
  Clutch ---
                Planing
                Displacement
  e Sail
                Outboard
    
```

Actual boat type is selected by turning the rotary course knob. The options are: Planing, Displacement, Sail and Outboard.

Type of boat selected will affect the steering parameters, and the functions available in the autopilot system. Select appropriate *Boat type* and press **STBD** button.

Drive unit voltage

Set the drive unit voltage to correct level. The selections are 12V, 24V, or 32V and should be set to the voltage specified for your drive unit.

Refer to the drive unit table on page 72 for information.

The drive engage/bypass clutch output follows the same voltage as set for the drive unit. It is not possible to select a higher voltage than the input voltage.

Caution !

Selection of improper voltage level for your drive unit may damage both the drive unit and the autopilot computer even if the protection circuits in the autopilot computer are activated.

During the Rudder Test, the AP25 system will automatically detect whether the drive unit is a reversible motor or a solenoid is operated.

```

INSTALLATION
      Dockside
Boat type           Sail
→ Drive unit voltage 12V
Rudd feedb cal STBD --°
Rudd feedb cal PORT --°
Rudder test        ----
----- drive
Clutch ---
                                     e 12V
                                     24V
                                     32V
    
```

To change the voltage selection, rotate the course knob.

Note !

The drive unit voltage setting does not apply when operating solenoids on a continuous running pump/steering gear. Hence, the output voltage to the solenoids will be the same as the input voltage.

Proceed to next menu item by pressing **STBD** button.

Rudder Feedback Calibration

Make sure the RF300 is installed and aligned as pr. instruction in section 3.6 (or eventually section 3.27 for LF3000). This function enables you to compensate for any non-linearity in the transmission between the rudder and the rudder feedback.

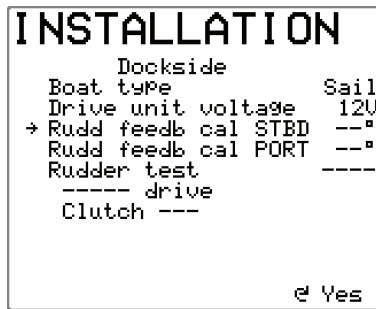

Confirm Rudder feedback calibration to STBD by turning the course knob clockwise.

Manually turn the helm to starboard until the rudder stops at starboard lock (H.O.).

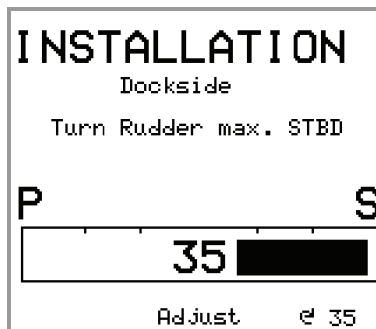

The value on the display is the angle read by the rudder feedback unit before any adjustment is made. If the actual rudder angle is different from that of the display, correct the reading by turning the course knob clockwise to increase the value or counter clockwise to decrease the value. See note.

Advance to the next step by pressing the **STBD** button.

Manually turn the helm to port until the rudder stops at maximum port rudder.

Adjust the displayed angle the same way as for starboard rudder.

Note !

Many boats have $\pm 45^\circ$ (90° H.O. - H.O.) rudder angle as standard. So if you are not making any adjustment to the display readout (i.e. not turning the course knob), the AP25 will set a (default) value of 45° to each side. However, you should always simulate an adjustment by turning the course knob clockwise and then back again. This is necessary to prevent the rudder from hitting the end stops.

Rudder zero may still be inaccurate and should be adjusted later during sea trial.

Proceed to next menu item by pressing **STBD** button.

Rudder Test

Note ! *If the boat uses power assisted steering, it is important that the engine or electric motor used to enable the power assist steering be turned on prior to this test.*

Bring the rudder manually to midship position before starting the test.

Caution ! *Stand CLEAR of the wheel and do not attempt to take manual control of the wheel during this test!*

```

INSTALLATION
  Dockside
  Boat type           Sail
  Drive unit voltage  12V
  Rudd feedb cal STBD 45°
  Rudd feedb cal PORT 45°
→ Rudder test       ----
  ---- drive
  Clutch ---
                                     e Yes
    
```

Activate the automatic rudder test by turning the course knob clockwise.

Note!
The automatic rudder test can be aborted any time by pressing the STBY button.

```

INSTALLATION
  Dockside
  Automatic rudder test
  =>Testing rudder<=
  P           S
  [-----]
  [         00         ]
    
```

The AP25 will after a few seconds issue a series of PORT and STBD rudder commands to automatically verify correct rudder direction. It detects minimum power to drive the rudder and then reduces the rudder speed if it exceeds the maximum recommended speed (8°/sec.) for autopilot operation.

The **Rudder test** is verified by the display showing ‘Motor OK’, ‘Solenoids OK’, or ‘Failed’. If ‘Failed’ is given, check for correct electrical connection.

When test is finished the display will read:

```

INSTALLATION
  Dockside
  Boat type           Sail
  Drive unit voltage  12V
  Rudd feedb cal STBD 45°
  Rudd feedb cal PORT 45°
→ Rudder test       Done
  Motor drive out 000%
  Clutch NOT Installed
                                     e Yes
    
```

```

INSTALLATION
  Dockside
  Boat type           Sail
  Drive unit voltage  12V
  Rudd feedb cal STBD 45°
  Rudd feedb cal PORT 45°
→ Rudder test       Done
  Solenoid drive
  Clutch NOT Installed
                                     e Yes
    
```

or

The *Motor Drive out* (displayed in percentage) is the amount of available power needed to achieve recommended rudder speed when on automatic steering Maximum speed (100%) is used in NFU mode. See also “Final Sea Trial” on page 132.

The screen also tells whether a clutch is installed or not.

If the Automatic rudder test fails, refer to ”Alarms” beginning on page 139

Test of LF3000/LFI3000 Mk2 feedback

1. *Align engines to centre position; “zero rudder”.*
2. *Rev engines to 3-4000 rev/min and observe the rudder angle indicator on the autopilot, a 2° change in the reading should be accepted.*
3. *If the rudder angle exceeds 2°, connect the screen on the TBI cable to the centre block terminal and repeat item 2 (See Figure 3-30). If this gives a better result keep the screen connected.*

Proceed to next menu item by pressing **STBD** button.

Drive engage

```

INSTALLATION
      Dockside
→ Drive engage  BYP/CLUTCH
  Rudder deadband  AUTO
    
```

This determines the use of the autopilot computer drive engage port (BYPASS/CLUTCH terminals). The port voltage is the same as the selected drive unit voltage. Drive engage has the following settings:

Bypass/clutch:

The port will activate (go high), in all autopilot steering modes, and typically engages a bypass valve on a hydraulic linear drive or a clutch on a mechanical drive when entering any of the active autopilot modes. This is the default setting and it allows you to steer the boat with the helm or wheel when in STBY or DODGE modes.

Auto:

This setting is implemented for future use. Always use the “Bypass/clutch” (default) setting.

Rudder Deadband

```

INSTALLATION
      Dockside
      Drive engage  BYP/CLUTCH
→ Rudder deadband  AUTO
    
```

The rudder deadband function is adaptive and is continuously operative. It prevents the rudder from hunting and the adaptive function optimizes the deadband to the speed of the boat and the pressure on the rudder.

If the auto-setting does not perform properly due to high inertia from the wheel or a loose steering gear, it can be adjusted manually.

Adjust the *Rudder deadband* by rotating the course knob. Find the lowest possible value that will prevent the rudder from hunting. A wide deadband will cause inaccurate steering. It is recommended to check rudder stability and accuracy in FU-mode when the boat is moving to get pressure on the rudder.

Range: AUTO, 0.1° to 4.0° in 0.1° increments.

Default: AUTO.

Proceed to the next menu item by pressing the **STBD** button.

Note !

The rudder deadband setting is not available when the autopilot is configured for Virtual feedback.

Wind setup

Wind setup is only available if 'Boat type' is set to 'Sail' in the Installation/Dockside menu.



Wind setup has two levels: NORMAL and RACING. The RACING level will give access to more wind setup items to achieve optimal performance when sailing. Additional setup items also become available in the User setup and the Quick setup menus.

Range: NORMAL and RACING

Default: NORMAL

Minimum wind angle (NORMAL)



The 'Minimum wind angle' is the minimum apparent wind angle that will keep the sails well shaped and give an acceptable thrust. This parameter will vary from boat to boat.

The 'Minimum wind angle' applies in the tack-prevent function. It also applies when the autopilot is navigating in Wind mode.

Range: 15 – 90°

Default: 30°

Minimum wind angle (RACING)

```

INSTALLATION
  Dockside
  Drive engage  BYP/CLUTCH
  Rudder deadband  AUTO
  Wind setup      RACING
  → Min. windangle STBD  35°
  Min. windangle PORT  30°
  Tack angle AUTO    100°
  Tack time         12s
  Wind shift limit   30°
    
```

If 'Wind setup' is set to RACING, you can set different minimum wind angles for port and starboard. The difference between port and starboard wind angles will be taken into account when calculating the Estimated Time to Turn (ETT) and Distance To Turn (DTT).

The minimum wind angle also applies when the autopilot is optimising the VMG (available parameter in the Quick setup menu when 'Wind setup' is set to RACING).

Range: 15 – 90°

Default: 30°

Tack angle (RACING)

```

INSTALLATION
  Dockside
  Drive engage  BYP/CLUTCH
  Rudder deadband  AUTO
  Wind setup      RACING
  Min. windangle STBD  35°
  Min. windangle PORT  30°
  → Tack angle AUTO    100°
  Tack time         12s
  Wind shift limit   30°
    
```

The autopilot can also tack in AUTO-mode. The set tack angle replaces a similar change of the set course using the course knob.

Range: 50 – 150°

Default: 100°

Tack time (RACING)

```

INSTALLATION
  Dockside
  Drive engage  BYP/CLUTCH
  Rudder deadband  AUTO
  Wind setup      RACING
  Min. windangle STBD  35°
  Min. windangle PORT  30°
  Tack angle AUTO    100°
  → Tack time         12s
  Wind shift limit   30°
    
```

When performing a tack in WIND-mode, the rate of turn can be limited. This will give single handed sailors time to handle the boat and the sails during a tack. The tack time is the time needed for the sailor to initiate the tack, start using the winches and haul the foresail from one side to the other.

A turn performed without shifting wind side, will also be made at a reduced turn rate. Shifting wind side when gybing, however, is an instant action from the autopilot and there is no limitation of the turn rate when making a gybe.

Range: 2 – 50 seconds

Default: 12s

Wind shift limit (RACING)

```
INSTALLATION
  Dockside
  Drive engage BYP/CLUTCH
  Rudder deadband AUTO
  Wind setup RACING
  Min. windangle STBD 35°
  Min. windangle PORT 30°
  Tack angle AUTO 100°
  Tack time 12s
  → Wind shift limit 30°
```

The monitored wind shift in WIND-mode is the wind shift angle measured from the last time the wind angle was set on the autopilot. If this wind shift exceeds the ‘Wind shift limit’, a wind shift alarm will be activated.

The wind shift monitoring can be turned off by setting the ‘Wind shift limit’ to ‘OFF’.

Note !

A wind shift reading is also presented in the ‘Wind shift’-display. This is the change of wind direction measured from the last time the autopilot mode was changed, e.g. STANDBY to AUTO, AUTO to WIND. This wind shift reading is for information only, and not to activate the wind shift alarm.

Range: OFF, 2 – 90°

Default: 30°

Dockside settings when configured for Virtual Feedback

The Virtual Feedback algorithms in the autopilot software enable your autopilot to steer without having to mount a conventional rudder feedback unit. These algorithms are designed for vessels up to 40 ft. powered by outboard or stern drives only.

Installing a feedback unit, however, will always enhance the performance of an autopilot and provide an accurate rudder angle indicator on the autopilot display. Unless impractical or impossible, a rudder feedback unit should be installed.

Note !

The autopilot is automatically configured for Virtual Feedback when there is no feedback unit connected at first time turn on, or at turn on after a Master Reset has been performed (Page 132).

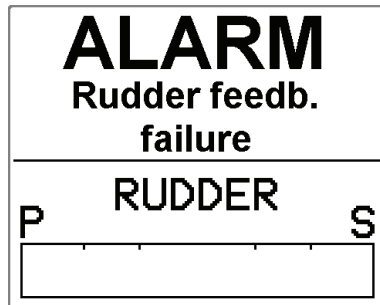

At first time turn on the autopilot will after approx. 5 seconds sound and display a feedback failure alarm. Press the **STBY** button to silence the alarm and follow the instructions in the display to initiate the Setup as described on page 95.



Press and hold the **INFO/SETUP** button to enter the Installation setup menu. Select “Dockside” and turn the course knob clockwise to open the “Dockside” menu. This will automatically configure the autopilot for Virtual Feedback, and the alternating feedback alarm will disappear from the display.



When the autopilot is configured for Virtual Feedback the *Boat type* is automatically set to *Outboard*.

The (autopilot) *Drive unit voltage* should be set to the voltage specified for your drive unit. See page 101.

```

INSTALLATION
  Dockside
  Boat type      Outboard
  Drive unit voltage 12V
  → Virtual fb cal STBD 45°
  Virtual fb cal PORT 45°
  Rudder test
  ---- drive
  Clutch ---
    
```

Virtual Feedback calibration

To perform the Virtual Feedback calibration and rudder test you must be able to view the movement of the engines/drives (“rudder”).

The Virtual feedback calibration is entered as a numerical value equal to the physical rudder angle observed at the hard over position.

Use the course knob to enter the starboard and port rudder angle.

```

INSTALLATION
  Dockside
  Boat type      Outboard
  Drive unit voltage 12V
  Virtual fb cal STBD 45°
  Virtual fb cal PORT 45°
  → Rudder test
  ---- drive
  Clutch ---
    
```

⌂ Yes

Rudder test

Activate the automatic rudder test by turning the course knob clockwise.

```

INSTALLATION
  Dockside
  Automatic rudder test
  ≧Use wheel≦
  Center rudder
  P _____ S
    
```

⌂ Yes

While observing the rudder position, use the wheel to center the rudder. Confirm by turning the course knob clockwise.

```

INSTALLATION
  Dockside
  Automatic rudder test
  Press and hold <TURN>
  Release after 3 sec.
  P _____ S
    
```

The next step is to enter the correct direction of the rudder movement.

Press and hold the **TURN/DODGE** button. Observe the rudder movement. Release the button after 3 seconds.

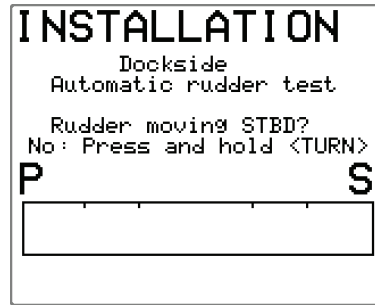

If the rudder is not moving so as to give a starboard turn, press and hold the **TURN/DODGE** button for another 3 seconds.

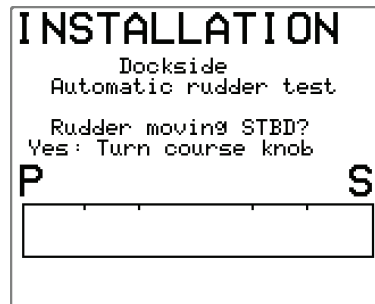

When the rudder is moving to starboard, turn the course knob clockwise to confirm.

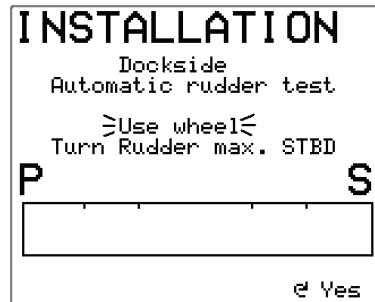

While observing the rudder, use the wheel to turn the rudder hard over to starboard position. Turn the wheel carefully a little to port just to release the hydraulic pressure. When ready confirm by turning the course knob clockwise

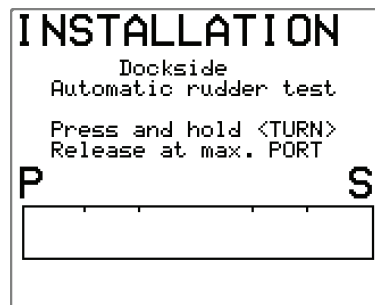

Press and hold the **TURN/DODGE** button.



Release the button when the rudder reaches the port hard over position.

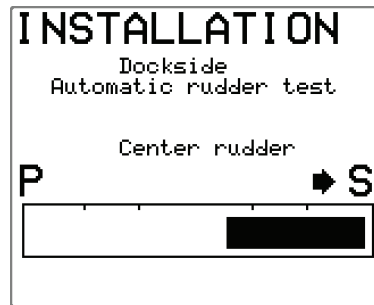

The rudder will now be automatically centered.

Note!

The reading in the rudder angle display is not showing a rudder angle, only the direction of the rudder movement.

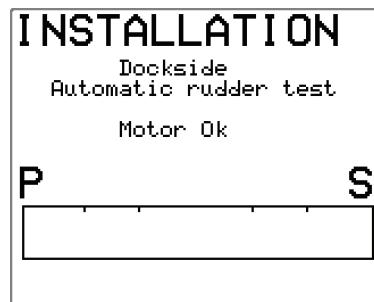

The **Rudder test** is verified by the display showing 'Motor OK' or 'Failed'. If 'Failed' is given, check for correct electrical connection.

When test is finished the display will read:



Drive Engage

See page 105



4.5 Interface Settings

Sets the format of the clock/data output for radars connected to the Autopilot Computer.

```

INSTALLATION
Language
Dockside
→ Interface
Display units
Seatrial
Parameters
Service

SW 1.1.00.16
Feb 9 2005
13:49           e Yes
    
```

Step to the Interface part of the Installation Menu.

Turn the course knob clockwise to access the Interface Setup items.

```

INSTALLATION
      Interface
→ RADAR  SIMRAD  Output
                        e SIMRAD
                        FURUNO
    
```

Use the course knob to select the connected type of radar.

Note!

This setting is not available in the AC10 Autopilot Computer.

4.6 Display units

```

INSTALLATION
Language
Dockside
Interface
→ Display units
Seatrial
Parameters
Service

SW 1.1.00.16
Feb 9 2005
13:49           e Yes
    
```

Select *Display units* by pressing **STBD** button and confirm by rotating the course knob clock-wise. The setup is local to each control unit.

```

INSTALLATION
      Display units
→ Wind Speed           kt
Sea temp               °F
Depth                  m
    
```

This screen gives access to the display unit set-up of the *Wind Speed*, *Sea temperature* and *Depth*.

Use the **STBD** button to select an item and the course knob to select the unit.

Available units are: Wind Speed: kt or m/s
Sea temperature: °F or °C
Depth: m or ft

Exit the Display units menu by pressing **STBD** button to proceed to the Sea trial menu, or press **STBY** to return to normal AP25 operation.

4.7 Sea Trial

Caution ! *The Sea Trial must always be performed in open waters at a safe distance from other traffic.*

The Sea-trial menu can only be accessed if the Dockside Settings are completed and confirmed.

The seatrial settings are:

- Rudder zero adjust (To tell the AP25 the precise midships position of the rudder)
- Minimum rudder
- Compass calibration (To automatically compensate for onboard magnetic interference)
- Compass Offset (To compensate for a fixed offset (A-error) in the final compass heading readout)
- Wind Offset (To compensate for a fixed mechanical offset of the Wind vane)
- Wind Damping (To avoid flickering on the wind display)
- Depth offset (To compensate for the distance between the depth transducer and the surface if required)
- Automatic tuning (A method of determining the steering parameters)
- Transition speed (the speed at which you want a power boat to change steering parameters)
- Init NAV (to set the response you prefer when steering onto a track in NAV mode)
- Set thrust direction (optional, only if interfaced to a thruster)
- Drive output adjust (See Final sea trial, page 132).



Select *Seatrial* by pressing the **STBD** button and confirm by rotating the course knob clock-wise.

Set Rudder zero

(Not applicable when configured for Virtual feedback)

This adjustment should be made in calm sea and side forces from wind or current should be avoided.

- Bring the boat up to cruising speed, and head directly into the wind.
- If the boat has twin engines, synchronize the engine RPM's.
- Set the trim tabs and stabilizers to have no effect on the boats heading.
- Steer the boat manually on a steady course.
- Confirm the rudder ZERO position by rotating the course knob clockwise.

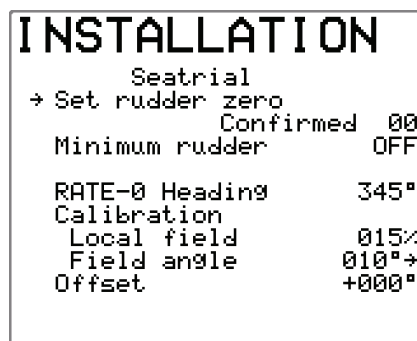
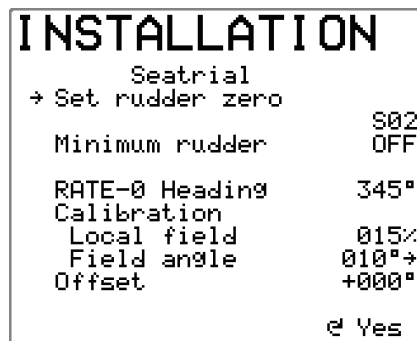

Press **STBD** to proceed to next menu item.

Minimum rudder

Some vessels may have a tendency of not responding to small rudder commands around the “course keeping” position because of a small rudder, a rudder deadband or whirls/disturbance of the water-stream passing the rudder.

By turning the Minimum Rudder function ‘On’, it may hence improve the course keeping performance on some boats, but it will increase the rudder activity.

INSTALLATION		
Seatrial		
Set rudder zero		00
→ Minimum rudder		OFF
RATE-0 Heading		345°
Calibration		
Local field		015%
Field angle		010°→
Offset		+000°

Turn the minimum rudder on by turning the rotary course knob.

Range: OFF-ON.

Default: OFF

Note !

During the sea trial, only set Minimum Rudder to ON if it proves to give a better course keeping performance in calm sea. It should be set after the autotune has been performed and a possible fine tune of the Rudder parameter (page 127).

Compass calibration

This function will activate the compass calibration procedure for Simrad compasses connected to Robnet2 and the Autopilot Computer terminals (HS).

Notes !

1. *The RC36 Rate Compass that comes with the autopilot as standard will store the calibration and off-set data in its own memory.*
2. *Compass calibration for a second compass connected to the HS terminal will be stored in the Autopilot Computer memory.*
3. *Calibration is made on the compass that is active for the autopilot. The active compass is the one that is displayed on the compass calibration screen.*

RATE-0 = Rate compass, FLUX-0 = Fluxgate compass on HS terminals.

4. If an optional NMEA compass from Simrad or another manufacturer is installed, also refer to the optional compass' manual regarding calibration. This compass will not be calibrated by the autopilot.

Before you start the compass calibration, make sure you have enough open water around you to make a full turn with the boat.

The calibration should be done in calm sea conditions and with minimal wind to obtain good results. Use about 60-90 seconds to make a full circle.

```

INSTALLATION
  Serial
  Set rudder zero
  Minimum rudder      00
                     OFF
  RATE-0 Heading     345°
  =Calibration<      > <
    Local field      015%
    Field angle      010°+
    Offset           +000°
    
```

Increase speed: >>>>>

Decrease speed: <<<<<

Appropriate speed: > <

1. Select the 'Calibration' item on the display
2. Begin turning the boat (port or starboard).
3. Confirm start of calibration by turning the course knob clockwise. The display will flash "Calibrating". Establish your turning rate using the arrows in the display.
4. When the calibration is completed, (after having made approximately 1 1/4 turns), it will be confirmed by the display reading "Confirmed".

Compass deviation

The heading from a magnetic heading sensor will normally have a deviation when compared with the actual direction of the earth's magnetic field. This is caused by interference from the boat's local magnetic field. The deviation will be at a minimum if the compass is placed as far as possible from any magnetic object on board. On the other hand, you may have to compromise with other requirements for the installation of the compass (page 79).

During the calibration, the compass will measure the magnitude and direction of the local magnetic field from where the compass is mounted. The magnitude is given in % of the magnitude of the earth's magnetic field. If the local magnetic field is stronger than the earth's magnetic field (the local field is reading more than 100%), the compass calibration will fail. If the local field is reading more than 30%, you should look for any interfering magnetic objects and remove them, or you should move the

compass to a different location. The local field angle will aid you to the local interfering magnetic object. See drawing.

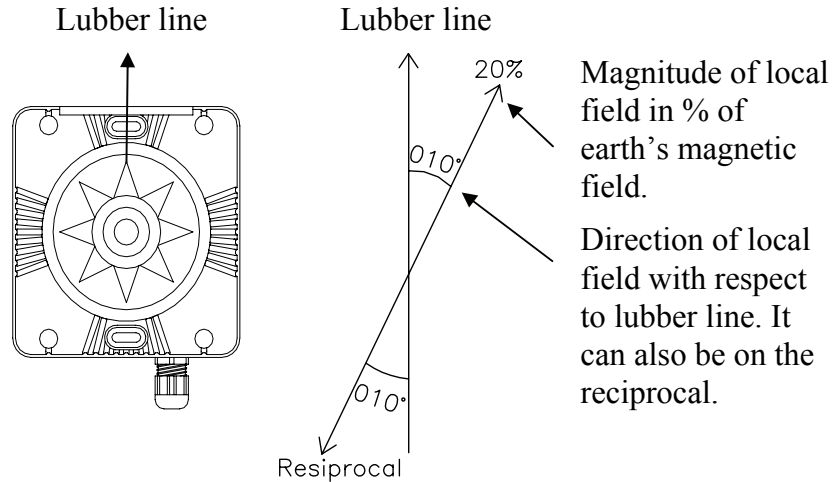

Note ! *In certain areas and at high latitudes the local magnetic interference becomes more significant and heading errors exceeding $\pm 3^\circ$ may have to be accepted.*

Compass Offset

After calibration, also check the compass readout against a known reference, a compensated compass or a bearing. If the reading has a fixed offset, proceed to next menu item by pressing **STBD** button or return to STANDBY mode by pressing the **STBY** button.

Note ! *Offset correction is always performed after the calibration. If you use COG as a reference for the offset remember it has to be a magnetic reading.*

The compass OFFSET feature allows you to correct for a fixed heading offset. This offset may be present as a result of the compass being installed with a lubber line offset or if a fixed offset remains after the calibration procedure has been completed. The value of compass offset is specific to the heading sensor that is selected at the time the offset is entered. This means that you can have individual offsets for each compass installed.

```

INSTALLATION
  Seatrial
  Set rudder zero      00
  Minimum rudder      OFF
  RATE-0 Heading      345°
  Calibration
  Local field          015%
  Field angle          010°→
  → Offset              +000°
  
```

Select the amount of correction by turning the course knob to offset the heading to agree with the known, accurate heading. The *Offset* value can be either positive or negative.

Note !

If an OFFSET still exists after having compensated for it, one of the following problems may still exist:

- The heading reference to which you are comparing the compass is not correct.
- The automatic calibration is not correct. Refer to above “Compass deviation”.

Proceed to the next menu item by pressing the **STBD** button, or return to Standby mode by pressing the **STBY** button.

Set Thrust Direction

(Only applicable if a thruster is connected)

```

INSTALLATION
  Seatrial
  Set rudder zero      00
  Minimum rudder      OFF
  RATE-0 Heading      345°
  Calibration
  Local field          015%
  Field angle          010°→
  Offset              +000°
  → Set thrust direction
  e Yes
  
```

Rotate the course knob clockwise to activate the *Set thrust direction* setting.

Rotate the course knob CW and verify that the vessel turns to starboard. The thruster stops after 10 seconds, or when the **STBD** button is pressed.

If the boat turns to port when the course knob is turned CW, rotate the knob to port to ensure a starboard turn.

The autopilot has now been set to the correct thrust direction.

On thrusters, a change in direction command will always be delayed 1 second to prevent thruster breakage.

Wind Offset

Note !

This offset only applies if you have a wind transducer directly connected to SimNet (IS12TW) or a wind transducer that outputs data on NMEA2000 format.

The Wind Offset feature allows you to correct for a fixed wind angle offset. Steer the boat directly into the wind with a damping of 15s. Keep the bow a steady heading for 15-20 sec. and read the wind angle. If necessary turn the course knob to input an offset that makes the display read Wind 000°.

```

INSTALLATION
      Serial
NMEA-1 Wind      R012°A
→ Offset          ---°A
Damping          20s
NMEA-1 Depth     329.0ft
Offset           -.-ft
Automatic tuning

Transition speed  05kn
Init NAV         Firm
NAV change limit  --°
    
```

The *Offset* value can be either positive or negative.

Wind damping

```

INSTALLATION
      Serial
NMEA-1 Wind      R012°A
Offset          ---°A
→ Damping        20s
NMEA-1 Depth     329.0ft
Offset           -.-ft
Automatic tuning

Transition speed  05kn
Init NAV         Soft
NAV change limit  --°
    
```

Damping of the apparent wind angle is made by the Advanced Wind Filter (AWF) in the Autopilot Computer. The inputs to the AWF are heading, boat speed, apparent wind angle and wind speed. Verify that these inputs are available in User Setup2/Source Select.

Heading sensors, speed sensors and wind sensors have variable performance. The measured wind angle can be very erratic when the boat is rolling heavily. In such conditions the AWF gives a better result when the calculations are based more on heading and boat speed inputs to achieve the correct apparent wind angle. Increasing the ‘Wind damping’, will make the AWF depend more on heading and boat speed to calculate the correct apparent wind angle. Decreasing the ‘Wind damping’, will make the AWF depend more on the “raw” apparent wind angle data.

The boat speed input to the AWF is primarily Speed Over Ground (SOG). If this is not available, the AWF will use speed

through water. If none of these are available, the AWF will use a boat speed that is 1.5 times the Transition Speed set in the Installation/Seatrial menu. Turn the course knob to adjust the wind damping.

Range: 1 – 100 seconds

Default: 15 seconds

Depth Offset

Note !

This adjustment only applies to “smart” depth transducers that outputs depth on NMEA2000 format. NMEA0183 sentence ‘DPT’ contains offset and the depth reading is from the surface. NMEA0183 sentence ‘DBT’ contains no depth offset and the reading will be from the position of the transducer.

```

INSTALLATION
      Seatrial
NMEA-1 Wind      R012°A
Offset           ---°A
Damping          20s
NMEA-1 Depth     329.0ft
→ Offset         -.-ft
Automatic tuning

Transition speed  05kn
Init NAV         Soft
NAV change limit ---°
    
```

When the depth offset is set to zero, the indicated depth is from the transducer to the bottom. To read the depth from the water surface to the bottom you have to set the depth offset according to the vertical distance between the surface and the transducer, i.e. positive (+) value

To read the depth from the keel to the bottom you have to set the depth offset according to the vertical distance between the transducer and the keel, i.e. negative (–) value.

Automatic tuning

Automatic tuning is a feature that automatically sets the two main steering parameters (Rudder and Counter Rudder) by taking the boat through a number of S-turns. The scaling factors of the parameters are also set automatically as a function of the boat type selection performed in the Dockside menu.

Automatic tuning is an optional procedure that is not required for the AP25 to function. The AP25 is preset with steering parameters that should steer most boats in the 30 - 80 foot range. It is, however, recommended to perform an automatic turning as part of the sea trial.

Recommended speed during *Automatic tuning* varies with the type of boat, but should not exceed 10 knots. It should be performed in calm or moderate sea conditions.

Note ! *Automatic tuning should not be performed at planing speed or in following seas!*

For displacement boats use a speed that is approximately half the normal cruising speed (i.e. if cruising speed is 10 knots, perform the *Automatic tuning* at about 5 knots).

The parameter values calculated during *Automatic tuning* becomes the HI parameters. The LO parameters are automatically set to 66% of the HI.

It also is recommended to perform the *Automatic tuning* steering East or West, as this will yield the best balanced parameters.

Note ! *After the Automatic tuning has been completed the rudder must be controlled manually, as the autopilot has returned to STBY mode.*

Caution ! *The Automatic tuning function will take control of the boat and perform a number of S-turns. It must always be performed in open waters at a safe distance from other traffic. The Automatic tuning function may take from 1 to 2 minutes to complete. To stop the Automatic tuning, press the STBY button.*

```

INSTALLATION
  Seatrial
NMEA-1 Wind      L000°A
Offset           ---°A
Damping          12s
NMEA-1 Depth     329.0ft
Offset           -.-ft
+ Automatic tuning

Transition speed  05kn
Init NAV         Soft
NAV change limit 10°
e Yes
    
```

Activate the Automatic tuning, by rotating the course knob clockwise. The display will flash "Automatic tuning".

After an *Automatic tuning*, there should be no need for further adjustments. "Fine tuning" of these parameters are made by the response control (see page 56). However, viewing or changing the parameters can be made from within the Parameter menu item. See also "Recall Autotune" on page 128.

Proceed to the next menu item by pressing the **STBD** button, or return to Standby mode by pressing the **STBY** button.

Transition Speed

The transition speed is the speed where the AP25 will automatically change the steering parameter set from HI to LO parameters, or vice versa (page 22).

The default setting of transition speed is 5 kts.

It is recommended that you set the transition speed to a speed that represents the speed where the hull begins to plane, or the speed where you change from slow to cruising speed.

The speed used for the automatic transition is obtained with the following priority:

1. Speed through water from the speed log source.
2. Speed Over Ground (SOG) from the GPS/Chartplotter.

If no speed data is available, manual speed selection is required. See also chapters 2.9 and 2.10.

```

INSTALLATION
      Seatrial
NMEA-1 Wind      R012°A
Offset           ---°A
Damping          20s
NMEA-1 Depth     329.0ft
Offset           -.-ft
Automatic tuning

→ Transition speed 05kn
Init NAV         Soft
NAV change limit ---°
    
```

Rotate the course dial clockwise until the transition speed is set to the desired value in knots.

Range: OFF – 30 knots

Default: 5 knots

Proceed to next menu item by pressing **STBD** button.

Init NAV

Sets a firm or soft approach to the track line when entering the NAV mode at the first leg. The approach angle is dependant (adaptive) on the distance (XTE) from the track line and the boat speed.

```

INSTALLATION
      Seatrial
NMEA-1 Wind      R012°A
Offset           ---°A
Damping          20s
NMEA-1 Depth     329.0ft
Offset           -.-ft
Automatic tuning

Transition speed 05kn
→ Init NAV       Soft
NAV change limit ---°
    
```

Select firm or soft approach to the track line by rotating the course knob.

Range: Soft - Firm

Default: Soft

NAV change limit

INSTALLATION		
Serial		
NMEA-1 Wind		R012°A
Offset		---°A
Damping		20s
NMEA-1 Depth		329.0ft
Offset		-.ft
Automatic tuning		
Transition speed		05kn
Init NAV		Soft
→ NAV change limit		10°

In NAV mode, when the required course change at the approaching waypoint is bigger than the set limit, you are prompted to verify that the upcoming course change is acceptable. The limit can be set to 10°, 20° or 30°.

Default: 10°

Rudder play compensation.

(Only applicable when configured for Virtual feedback)

Notes!

1. *To obtain the best possible steering performance the said procedures must be performed in the following order:*
 - Perform an autotune at 6-8 knots in calm sea.
 - If necessary fine tune the Counter Rudder parameter (see page 126) at cruising speed (LO value) and at slow speed (HI value)
 - Use the response control to obtain the best possible course keeping (page 56).
2. *If the autopilot performance is found satisfactory when the above has been completed, skip the following rudder play compensation procedure. The rudder play compensation procedure is only necessary if the steering gear is sloppy. Using this procedure when not required may interfere with the steering algorithms and result in poorer steering instead of providing improvements.*

A play in the steering gear will always reduce the steering performance of the autopilot. The best result is obtained when sloppy linkages are repaired and this is the recommended course of action.

Note !

With a rudder feedback unit installed the effect of the rudder play is significantly lessened.

When rudder play still exists and there is no feedback unit installed, the autopilot will need some assistance from the installer to compensate for this. The effect of the rudder play is

4.8 Parameters

```

INSTALLATION
Parameters
→ Rudder LO 0.35
Cont.Rudder LO 1.00
Autotrim LO 40 sec
Rudder Lim. LO 20°
Rudder HI 0.50
Cont.Rudder HI 1.40
Autotrim HI 40 sec
Rudder Lim. HI 20°
Recall Autotuned?
    
```

A boats steering parameters found by the Automatic tuning can be looked at and if needed changed under this menu item. The steering parameters can also be set manually instead of performing an Automatic tuning. The parameters are divided into two sets (page 23):

- HI value parameters for automatic steering at low speed and when running with a sailboat.
- LO value parameters for automatic steering at high speed and when sailing into the wind or reaching with a sailboat.

Manual parameter adjust

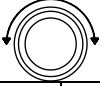
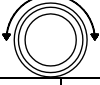
Displayed parameter	Boat type		Own boat	
	Displacem. & Sail	Planing & Outboard	Automatic tuning	Manual
LOW				
Rudder LO	0.35	0.20		
Cont.Rudder LO	1.00	1.00		
Autotrim LO	40 sec.	40 sec.		
Rudder Lim LO	20°	20°		
Hlgh				
Rudder HI	0.50	0.30		
Cont.Rudder HI	1.40	1.40		
Autotrim HI	40 sec.	40 sec.		
Rudder Lim HI	20°	20°		

Use course knob to adjust parameters

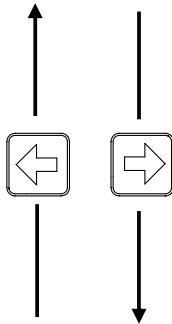

Use PORT and STBD buttons to step through parameters

Note ! *The values in the table are factory set (default) and listed for information only. After having performed the Automatic tuning, the values may differ from those listed in the table. See also “Automatic Tuning” previously in this chapter.*

Note ! *With Virtual Rudder Feedback use 20 seconds time constant for Autotrim.*

The two most important parameters that determine the performance of the automatic steering are Rudder and Counter Rudder.

Rudder sets the rudder gain which is the ratio between the commanded angle and the heading error.

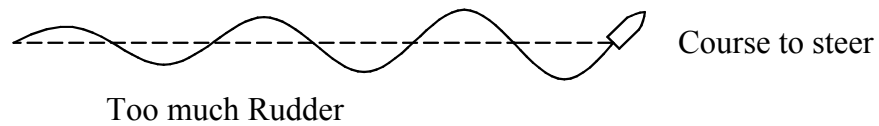
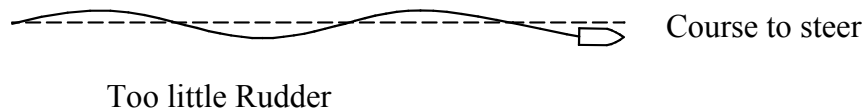

- Too little Rudder and the autopilot fails to keep a steady course.
- Too much Rudder gives unstable steering and reduces speed.
- Low speed requires more Rudder than high speed.

Note !

See also “Minimum Rudder” on page 115.

Counter Rudder is the parameter that counteracts the effect of the boats turn rate and inertia. For a short time period it is superimposed on the proportional rudder response as provided by the heading error. It may sometimes appear as if it tends to make the rudder move to the wrong side (counter rudder).

The best way of checking the value of the Counter Rudder setting is when making turns. The figures illustrate the effects off various Counter Rudder settings.

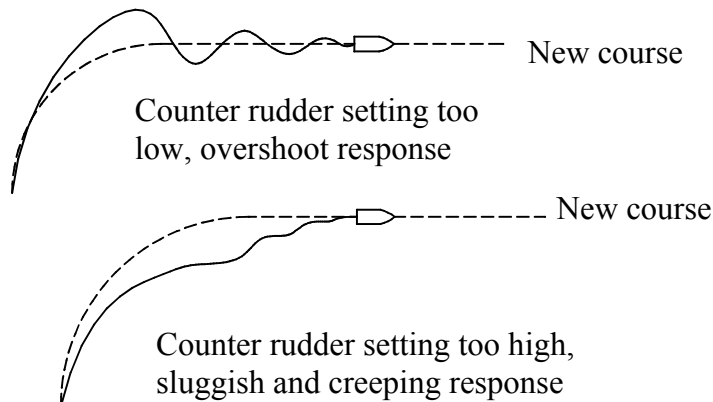

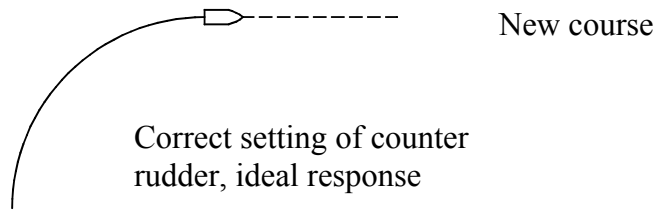

Autotrim standard value is 40 sec. which should work well on most boats.

Rudder Limit should be kept at 20 degrees unless there is a need for more rudder when performing dockside manoeuvres.

Recall Autotuned?

```

INSTALLATION
  Parameters
  Rudder      LO      0.35
  Cont.Rudder LO      1.00
  Autotrim    LO      40 sec
  Rudder Lim. LO      20°
  Rudder      HI      0.50
  Cont.Rudder HI      1.40
  Autotrim    HI      40 sec
  Rudder Lim. HI      20°
  → Recall Autotuned?
                                     e Yes
    
```

To recall the parameter values that were achieved during the *Automatic tuning* procedure, rotate the course knob clockwise. When parameter values are recalled, *Confirmed* is displayed.

Exit the Parameter menu by pressing **STBD** button to proceed to the Service menu, or press **STBY** to return to normal AP25 operation.

4.9 Service Menu

Select STANDBY mode and then enter the Installation Menu by pressing and holding the **INFO/SETUP** button for 5 seconds. Select "SERVICE" by pressing the **STBD** button and confirm by rotating the course knob clockwise.

```

INSTALLATION
  Service
  → System data
  SimNet/NMEA data
  NMEA 0183 Port test
  SimNet setup
  Sn 00000
  Master reset?
                                     e Yes
    
```

System data and *NMEA data* are test functions to analyze data processed by the AP25.

Sn 00000 is the unique SimNet ID number for the specific autopilot control unit.

To exit the menu, press any mode key (STBY, AUTO or NAV).

System Data Menu

```

INSTALLATION
  System data
  Steer compass  344.9°M
  Rudder        00.00
  Input voltage  25 V
  Drive out     078%
  Clutch/bypass
  installed
  
```

Select *System data* by rotating the course knob clockwise.

This menu provides you with additional system data that can be useful when testing or trouble shooting the system.

Steer compass

Steering Compass readout, M=Magnetic, T=True

Rudder

Rudder angle. Normally between zero and 45 degrees.

Input voltage

Mains voltage on input terminals

Drive out

Power needed to drive the unit in percent of full (100%) to get satisfactory rudder speed.

Clutch/bypass

Verifies if a clutch or bypass valve has been activated when performing the rudder test.

SimNet and NMEA Data Screen

```

INSTALLATION
  SimNet/NMEA data
  OK XTE      L 0.991NM
  OK BWR      270°
  OK BPW      270°
  OK LAT  N  00°07.490'
  OK LON  W 000°04.366'
  OK COG      345°
  OK SOG      08.00kt
  OK WIND      R 012°A
  OK SPEED    08.10kt
  OK DEPTH    329.0ft
  
```

Select the screen by pressing the **STBD** button and confirm by rotating the course knob clockwise.

The menu provides you with status information about the different SimNet and/or NMEA messages used by the system.

Decoding

The incoming signals are decoded according to a built in priority table in the AP25. Cross Track Error and bearing information are taken from the NMEA messages with highest priority.

For all data items, one of the following codes will be displayed:

- No data or no NMEA sentence containing the data needed is available at the input port.
- OK Valid data found
- INV Message with invalid information.
- FRM Message has format failure such as
 - a) Incorrect check sum
 - b) Wrong contents in datafield(s)

If data are missing or invalid, perform the following:

- Check the NMEA signal monitor (see below)
- Open the source select page in the User Setup2 menu and check that data are available
- Check the navigator setup and make sure it is transmitting appropriate data.
- Perform a NMEA Port Test (hardware) as per below.

Note !

The “WIND” reading is the apparent wind from port (L) or starboard (R). The “SPEED” reading is the speed through water.

NMEA signal monitor

Near the NMEA terminals in the Autopilot Computer you will find a green monitor LED marked “RX”. A flickering LED indicates that a NMEA signal is received. It does not, however, qualify the contents of the message.

Note !

Do not mix up the “RX” LED with the LED marked “TX”. The “TX” LED will always be lit or flickering when the autopilot is on.

NMEA Port test (AC hardware)

Disconnect the cables on the Main PCB in the Autopilot Computer and connect TX1+ to RX1+ and TX1- to RX1-. Similarly, on the Power PCB connect the NMEA ports the same way; TX2+ to RX2+ and TX2- to RX2-.

```

INSTALLATION
      NMEA Test
Loopback NMEA1      OK
Loopback NMEA2      NO
Checksum NMEA1      OK
Checksum NMEA2      OK
    
```

Under *Service* in the Installation Menu, select *NMEA port test* by pressing the **STBD** button and confirm this by rotating the course knob clockwise.

Verify that the hardware is OK. If not, replace the corresponding PCB('s).

Proceed to the Simnet Setup menu by pressing the **STBD** button, or press **STBY** to return to normal AP25 operation.

Simnet setup

```

INSTALLATION
      SimNet setup
→ Group selection
          SIMRAD
Backlight  STAND-ALONE
Instance number      00
SimNet gateway      Yes
Global SimNet reset?
    
```

Group selection

SIMRAD: Autopilot is part of the Simrad Group. Source selection will be common for the products in the group (synchronized).

STAND ALONE: Source selection for the autopilot will not be transferred to other products in the Simrad Group (no synchronization).

```

INSTALLATION
      SimNet setup
      Group selection
          SIMRAD
→ Backlight  STAND-ALONE
Instance number      00
SimNet gateway      Yes
Global SimNet reset?
    
```

Backlight Illumination

Set backlight to synchronize with one of the illumination banks (1-3) available on the SimNet, or to **STAND ALONE** for individual control of the autopilot illumination.

```

INSTALLATION
      SimNet setup
      Group selection
          SIMRAD
Backlight  STAND-ALONE
→ Instance number      00
SimNet gateway      Yes
Global SimNet reset?
    
```

Instance number

An item to identify units by a number when the autopilot is connected to a NMEA2000 Network. On SimNet units the Instance number is added to the product name e.g. AP25-1, AP25-2 for easy identification on various display screens.

```

INSTALLATION
  SimNet setup
  Group selection
                SIMRAD

  Backlight    STAND-ALONE

  Instance number    01
  SimNet gateway    Yes
  → Global SimNet reset?

                                     e Yes
    
```

SimNet gateway

Indicates which control unit that transmits and receives information on SimNet. The display verifies by reading ‘Yes’, all other units display ‘No’.

Global SimNet reset

Resets the entire SimNet setup in the Simrad Group and initiates a new automatic interface setup. See chapter 4.1.

Master Reset

Note !

A Master Reset is part of the final test at the factory, which will reset the memories to factory settings. Unless you need to clear all stored values during the installation setup procedure, you should not perform a Master Reset.

```

INSTALLATION
  Service
  System data
  SimNet/NMEA data
  NMEA 0183 Port test
  SimNet setup
  Sn 00000
  → Master reset?
  Warning:
  Will restore factory
  settings. New setup
  will be required
                                     e Yes
    
```

The Master Reset needs a double confirmation to prevent an accidental reset. To perform a Master Reset, rotate the course knob clockwise and observe the display; then rotate the course knob counter clockwise. The display will then read: “Master Reset confirmed”.

Unless you have made a Master Reset, exit the Installation Menu by pressing **STBY** to return to normal AP25 operation.

In the event a Master Reset has been made, refer to chapter 4.2.

Final sea trial

After having completed all settings in the Installation Menu, take the boat out and perform a final sea trial in open waters at a safe distance from other traffic.

- Steer the boat on all cardinal headings in AUTO mode.
- Start with low and medium speeds to get familiar with the response from the AP25.

- If the hardware for automatic HI/LO selection is connected and configured, verify that the HI/LO transition is occurring, and the HI/LO parameters are changing after the transition speed is crossed (by more than 1 Knot higher or lower speed).
- Try the effect of LO and HI parameter settings.
- Try the Dodge and U-turn function.
- If a Non-Follow Up lever (or handheld remote) is connected, test change of modes and verify port and starboard steering commands of the lever.
- Set waypoints into each navigator connected to the system, and verify that the AP25 steers in NAV mode for each NAV source.
- Try the NoDrift mode.
- If the boat is a sailboat use the WIND mode and try the AP25 at different settings of the apparent wind angle. Also try the WINDN(av) mode, optimized VMG and WCV when sailing (tacking) to a waypoint.
- If the rudder response feels aggressive during the sea trial, you may want to reduce the rudder speed to get a smoother steering.

Alternatively on a sailboat you may want to have a higher rudder speed when running. The motor Drive out (page 104) can be set with this in mind. Never adjust in more than 10% steps with respect to the reading set during the automatic rudder test (page 103). Always perform a new Autotune after the adjustment.

- Provide the owner with user training.

Providing user training

The user should be instructed in the "basic" operational functions, such as:

- Turning the system on and off
- Changing modes. Explain briefly what takes place in the different modes.
- Regaining manual control from any mode. Point out in what modes the helm is engaged by the autopilot (bypass/clutch).
- Taking command at an "inactive" station, if applicable.

- Using the lock mode, how to lock/unlock and how to shut the system down from a locked control unit, if applicable.
- Use of the Non-Follow-up and Follow-up steering modes and learning the difference between the two.

Note !

No Follow-up mode when configured for Virtual feedback

- Use of a Non-Follow-up and Follow-up controller, if connected.
- Changing course by rotary knob and buttons.
- Stepping through the User Set-up Menu learning how to (and why to) change the settings.
- How to select alternative sources for heading (compass), navigation (GPS, chart plotter), speed, depth etc. if available.
- Understand the difference between NAV mode and NoDrift mode and their data sources (Nav, Pos).
- Locating compasses and knowing to keep magnetic items away.
- Locating the Mains circuit breaker and the separate SimNet circuit breaker if provided.
- Knowing the use of thrusters with the autopilot.

5 MAINTENANCE

5.1 Control unit

The AP25 Control Unit will under normal use require little maintenance.

If the unit requires any form of cleaning, use fresh water and a mild soap solution (not a detergent). It is important to avoid using chemical cleaners and hydrocarbons such as diesel, petrol etc.

Make sure that all open Robnet2 connectors are fitted with a protection cap.

It is advisable at the start of each season to check all connections to the control unit head and cover with Vaseline or WD40. If the Control unit is not removed from the boat, it should be covered with the white protection cover.

5.2 Autopilot Computer

No special maintenance is required. It is advisable, however, at the start of each season to make a visual inspection of the internal and check all connections.

5.3 Rudder Feedback

Make a visual inspection at 2-3 month intervals and at the start of each season. Apply some grease at the ball joints when required (RF300)

5.4 Compass

If the compass is exposed to the weather, make a visual inspection at 2-3 months intervals, and at the start of each season.

5.5 Drive unit

Refer to the drive unit manual for maintenance instructions.

5.6 Exchange of software programme

Autopilot Computer

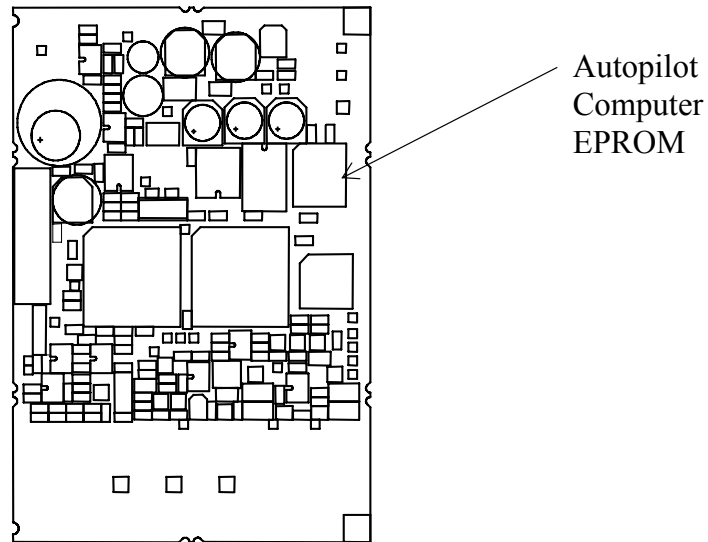
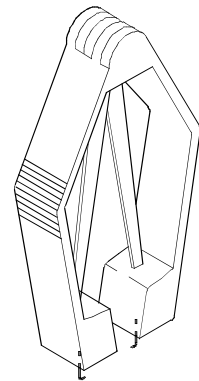

Figure 5-1 AC10/AC20/AC40 Main PC-Board

- Remove the EPROM from the socket by means of the special extraction tool (p/n 44139806).
- Insert the tool by pressing the two grip pins down into the two slots in the corners of the socket.
- Squeeze the tool and pull out the EPROM.
- The identification tag indicates:
 - Name of unit
 - Part number
 - Software version



Caution !

When inserting a new EPROM, make sure the cut-off corner matches with the one in the socket. Press it gently into the socket.

EPROM for AC10, AC20 and AC40
Autopilot Computers:
P/N 22088462

After change of EPROM, perform a master reset as described on page 132.

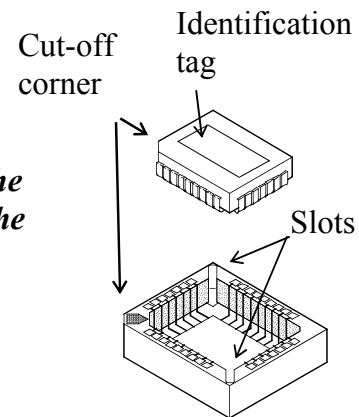

Autopilot Control Unit

You will need a special kit for a PC to perform the programming of the AP25 Control Unit. Order the following from Simrad:

Programming kit P/N 22088595.

Instructions are included.

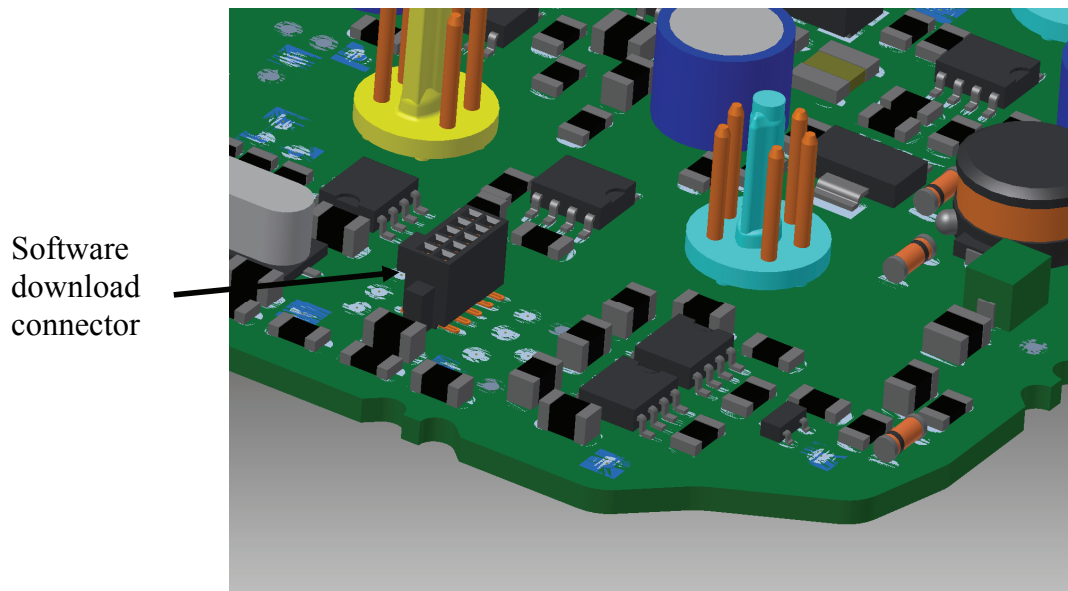

Figure 5-2 Part of AP25 PCB

Remove the cables and unscrew the six screws that secure the back cover. Apply a firm pull with your fingers to pull the back cover loose from the connector pins. Then you have access to the software download connector.

This page is intentionally left blank.

6 TROUBLE SHOOTING

An autopilot is a complex system. Its performance depends on a proper installation and a successful sea trial.

In the event of an autopilot failure, the AP25's numerous test features will assist you in isolating a probable fault.

Audible and visual alarm is provided for every fault being detected.

The audible alarm is reset by pressing any button (e.g. by changing mode from AUTO to STANDBY). All visual alarms will remain and alternate with the operating display until the fault has been rectified. Refer to the table below for hints and try to solve the problem yourself. You may also consult your nearest Simrad dealer for assistance, if required.

Perform any repair action in the listed sequence.

Notes!

1. *'Compass difference', 'Vessel off course', and 'Rudder limit' warnings are automatically reset when the error is rectified.*
2. *--- in a display indicates that data is missing.*

6.1 Alarms

Display readout	Probable fault	Recommended action
System failure Alarms:		
The boat is off course	Boats heading is outside fixed off course limit of 20 deg. (Automatic reset when inside limit.) Extreme weather conditions, too slow speed.	<ol style="list-style-type: none"> 1. Check steering parameters (Rudder, Autotrim, Seastate-filter). 2. Increase Rudder value 3. Increase boat speed, if possible, or steer by hand.
NAV. data failure	Missing or invalid NAV data.	<ol style="list-style-type: none"> 1. Check the Nav. Receiver/GPS setup. 2. See <i>Service menu</i> Chapter 4.9

Display readout	Probable fault	Recommended action
Shallow water	The depth is inside the set limit or outside the range, i.e. 100 m (328') Depth data is missing.	<ol style="list-style-type: none"> 1. Carefully observe the actual depth. 2. Adjust the alarm limit if not hazardous. 3. Steer to safe depth, the alarm will reset automatically. 4. Turn off the shallow alarm if depth data is missing (Page 54).
Compass data missing	No data from selected compass.	<ol style="list-style-type: none"> 1. If more than one compass is connected to the system, refer to the <i>User Setup2/Source select</i> menu to select a different compass. 2. Make a source update if no compass is available. 3. Check connections. 4. Replace compass PCB (<i>Note: Do not cut cables. There are screw terminals inside</i>).
Rudder feedback failure (not applicable for Virtual feedback installations)	Rudder feedback signal missing or erratic	<ol style="list-style-type: none"> 1. Check all connections. 2. Check the alignment as per the installation instructions 3. Replace rudder feedback unit.
Rudder response failure	No response to rudder command	<ol style="list-style-type: none"> 1. Check all connections 2. Check Rudder FB transmission link (not applicable for Virtual feedback installations). 3. Check drive unit motor/brushes. 4. Replace the Autopilot Computer Power PCB.
Rudder too slow	Excessive load on steering gear. Air in hydraulic system. Insufficient drive unit capacity.	<ol style="list-style-type: none"> 1. Look for mechanical obstructions at the rudder/tiller/quadrant. Check the back drive force. 2. Bleed the hydraulic system. 3. Replace with bigger pump unit.

Display readout	Probable fault	Recommended action
Rudder test failed	<p>Following conditions may exist:</p> <ul style="list-style-type: none"> a) Rudder feedback failure b) Autopilot Computer current overload c) Bypass/clutch overload 	Refer to recommended actions for the specific probable faults.
	<p>Rudder moves in only one direction</p> <ul style="list-style-type: none"> a) Poor connection to one of the solenoids (continuously running pump) b) Faulty Power PCB in autopilot computer 	<ul style="list-style-type: none"> a) Check the connections b) Replace the Autopilot Computer Power PCB
	<p>Rudder test not completed within 2 min.</p> <ul style="list-style-type: none"> a) Poor connections to the drive unit b) Faulty Main PCB in the Autopilot Computer c) Faulty Power PCB in the Autopilot Computer 	<ul style="list-style-type: none"> a) Check connections b) Replace the Main PCB c) Check the Power PCB for traces of burned transistors. – Change Power PCB.
	<p>Rudder moves at full speed to one side.</p> <ul style="list-style-type: none"> a) Faulty Power PCB in Autopilot Computer 	Replace Autopilot Computer Power PCB

Display readout	Probable fault	Recommended action
Failure active Control Unit	Active control unit goes silent.	<ol style="list-style-type: none"> 1. Press the STBY button on an "Inactive" unit to reset. 2. Check/repair RobNet2 cable. 3. Replace the control unit PCB.
ACXX current overload	The drive unit shut down due to an excessive load or a short circuit.	<ol style="list-style-type: none"> 1. Check the drive unit and drive unit installation/Manual steering/Rudder. 2. Disconnect the drive unit. If the fault is still present, replace the Autopilot Computer Power PCB.
Low 15 volt	Internal 15 Volt supply in Autopilot Computer below limit.	<ol style="list-style-type: none"> 1. Replace Autopilot Computer Main PCB 2. Replace Autopilot Computer Power PCB if Mains voltage is 12V.
Bypass/clutch overload	Clutch/bypass current exceeds 2,5 Amps (overload or short circuit).	<ol style="list-style-type: none"> 1. Check actual current 2. Check voltage marking on coil 3. Check coil resistance (through connecting wires)
Bypass/clutch disengaged	Poor connection or open circuit in bypass/clutch coil	<ol style="list-style-type: none"> 1. Check connections 2. Replace bypass/clutch if open. 3. Perform new "Rudder test".
ACXX high temp.	Excessive temperature in Autopilot Computer (>75°C), possible long term overload.	<ol style="list-style-type: none"> 1. Switch off autopilot 2. Check for backload in Drive unit/steering system. 3. Check that the autopilot computer specifications matches Drive unit.
Memory failure ACXX	Wrong checksum on memory parameters or variables. Autopilot Computer will use default values.	Perform a "Master reset" and make a new "Dockside set-up". Switch off and on again. If the alarm is repeated, replace Autopilot Computer Main PCB.

Display readout	Probable fault	Recommended action
Com. failure with ACXX	Faulty Autopilot Computer or poor Robnet2 cable connections from the same.	<ol style="list-style-type: none"> 1. Check Robnet2 connectors and cable. 2. Replace Autopilot Computer Main PCB.
Low supply voltage	Mains voltage less than 9 Volts	<ol style="list-style-type: none"> 1. Verify in the System Data Menu 2. Switch autopilot off, charge batteries 3. Check/repair battery charger
High supply voltage	AC20/AC40 Mains exceeds 44 V AC10 Mains exceeds 29 V	<ol style="list-style-type: none"> 1. Verify in the System Data Menu 2. Switch the autopilot off 3. Check / repair battery charger

7 SPARE PARTS LIST

AP25 Control Unit

- 22087811 AP25 Control Unit
- 22088405 Standard mounting kit consisting of:
 - 22084693 Gasket (2 mm)
 - 22086029 Gasket (7.5 mm)
 - 22084529 Cabinet corner
 - 44165181 Screw 3,5x19
 - 44165645 Screw 3,5x32
- 22084941 Optional mounting bracket consisting of:
 - 44148906 Screw M4x12
 - 22084768 Cradle
 - 22084776 Right bracket
 - 22084784 Left bracket
 - 22084859 Locking knob
 - 44163145 Locking washer for left and right bracket
 - 44163160 Cradle, locking washer
- 22087829 AP25 Front Housing Ass'y
- 22087894 Back cover with gasket
- 22087738 AP25 Board Ass'y
- 22084750 Protection Cover
- 22088199 AP25 Software

Autopilot Computers

- 22088108 AC10 Autopilot Computer
- 22088116 AC20 Autopilot Computer
- 22088124 AC40 Autopilot Computer
- 22081707 AC20 Installation accessories
- 22081855 AC10 Installation accessories
- 22081962 AC40 Installation accessories
- 22081251 AC20 Power PCB Ass'y
- 22081715 AC10 Power PCB Ass'y
- 22088694 AC40 Power PCB Ass'y
- 22088447 AC Main PCB Ass'y (All models)
- 22088462 EPROM for all autopilot computers

22081434 AC10/AC20 Base plate

22082036 AC40 Base plate

22081350 Main cover

22081368 Terminal cover

RFC35 Electronic Fluxgate Compass

22086995 RFC35 Fluxgate Compass

22081442 Installation accessories consisting of:

20104972 Mounting plate (2)

44140762 Screw 3.5x25 (2)

44140770 Screw 30x9 (4)

22081376 Plug (2)

22081178 RFC35 PCB Ass'y

RC36 Rate compass

22086920 RC36 Rate Compass

22081442 Installation Accessories Consisting of:

20104972 Mounting plate (2)

44140762 Screw 3.5x25 (2)

44140770 Screw 30x9 (4)

22081376 Plug (2)

22086938 RC36 PCB Ass'y

24005647 Robnet2 Cable, 15 m with Plug

RF300 Rudder Feedback Unit

20193744 RF300 Rudder Feedback

20193470 RF300 transmission lever

20193454 RF300 transmission link

44133122 Transmission rod M5x325mm

20193624 RF300 Ball joint Ass'y (2)

Robnet2 cables

- 24005613 Robnet2 cable, 1 m (3') with two plugs
- 24005621 Robnet2 cable, 5 m (16') with two plugs
- 24005639 Robnet2 cable, 10 m (33') with two plugs
- 24005647 Robnet2 cable 15 m (49') with one plug
- 24005662 Robnet2, T-joint

SimNet cables and accessories

- 24005829 SimNet cable 0.3 m (1')
- 24005837 SimNet cable 2 m (6.6')
- 24005845 SimNet cable 5 m (16.6')
- 24005852 SimNet cable 10 m (33')
- 24005860 SimNet T-joiner
- 24005878 SimNet cable gland
- 24005886 SimNet protection plug
- 24005894 SimNet termination plug
- 24005902 2 m (6.6') SimNet power w/termination
- 24005910 2 m (6.6') SimNet power w/o termination
- 24005936 AT10 Universal NMEA0183 converter
- 24005944 AT15 Active Tee w/connector, IS15
- 24005928 SimNet cable protection cap
- 24005729 SimNet cable to Micro-C. Adapter (drop) cable for SimNet products in a NMEA2000 network.

Tools

- 44139806 Extraction tool for EPROM

8 TECHNICAL SPECIFICATIONS

8.1 AP25 Autopilot System

- Boat size and type:..... Up to 80 feet, Power, Displacement, Sail
- Steering system types: Hydraulic, Mechanical
- Inter-unit connection: ROBNET2 network or two-wire supply/data
- System ON/OFF: From control units
- Supply voltage: See autopilot computers
- Power consumption: Dependent on system configuration
- Environmental Protection:
- Control Unit: IP56 from front, IP43 from back.
 - RC36, RFC35, CDI35: IP56
 - RF300: IP56
 - AC10, AC20, AC40:..... IP44
- EMC protection: EN60945 : 1993, A1 : 1993
- Automatic Steering control:
- Rudder Drive: Proportional rate or solenoid on/off
 - Parameter selection: Automatic with manual override
 - Sea state control: Adaptive sea state filter or manual
- Language selection: English, Norwegian, French, Spanish, German, Italian, Dutch, Swedish.
- Electronic Interface:
- Navigation interface:..... Standard (NMEA 0183)
- NMEA inp./outp. ports: Max. 6 (see autopilot computers)
- NMEA input sentences: APA, APB, BOD, BWC, BWR, BWW, DBT, DPT, GGA, GLL, MTW, MWV, RMA, RMB, RMC, VHW, VLW, VTG, XTE.
 - NMEA output sentences:.. BWC, BWW, GLL, HDG, HDM, HDT, HSC, RMB, RMC, RSA, VTG, XTE.
- See chapter 8.13 for NMEA0183 details.
- Optional output: Simrad and Furuno radar display (clock/data)
 - NMEA2000 interface..... Via SimNet port and SimNet/NMEA2000 adapter cable

Heading sensors:

- Standard: RC36 Rate Compass
- Options: RFC35 Electronic Fluxgate compass
- NMEA Compass (Not AC10)
- Simrad RGC50/RGC10 gyrocompasses *
- * By GI51

Course Selection: Rotary course dial and push button

Alarms: Audible and visual, optional external

Alarm modes: Off course, system failures, overload

Steering modes: Standby, Non-follow up, Follow-up, Auto, Nav, Wind

Special Turn modes: Dodging, Tacking, Gybing, U-Turn, C-Turn, Spiral, Zigzag, Square, Lazy S, Depth contour.

Instrument screen interface:

Instrument screen	NMEA0183 messages and SimNet
MAIN (HDG+RUDDER)	ROBNET2 PROPRIETARY, NMEA HDT and HTG, SimNet
SPEED/DEPTH	VHW + DBT/DPT, SimNet
APPARENT WIND	MWV, SimNet
TRUE WIND/WIND DIRECT	MWV + VTG/RMC; SimNet
MOTORWAY	APB + RMB + VTG + GGA/RMC, SimNet
POSITION	GGA/RMC/RMA, SimNet
NAV/TRACK DATA	APB + VTG/RMC + GGA/RMC + RMB/BWC, SimNet
LOG/SEA TEMPERATURE	VLW + MTW, SimNet

Note ! *Alternative messages are separated by slashes.*

8.2 AP25 Control Unit

Dimensions: See Figure 8-1

Weight: 0,5 kg (1.1 lbs)

Power consumption 3 W

Display:

Type: Backlit LCD matrix display

Resolution: 160 x 128 pixels

Colour: Black

Illumination: Adjustable in 10 steps

Environmental Protection: IP56 from front, IP43 from back.

Safe distance to compass: 0.5 m (1.6 ft.)

Temperature:

Operating: 0 to +55 °C (+32 to +130 °F)

Storage: -30 to +70 °C (-22 to +158 °F)

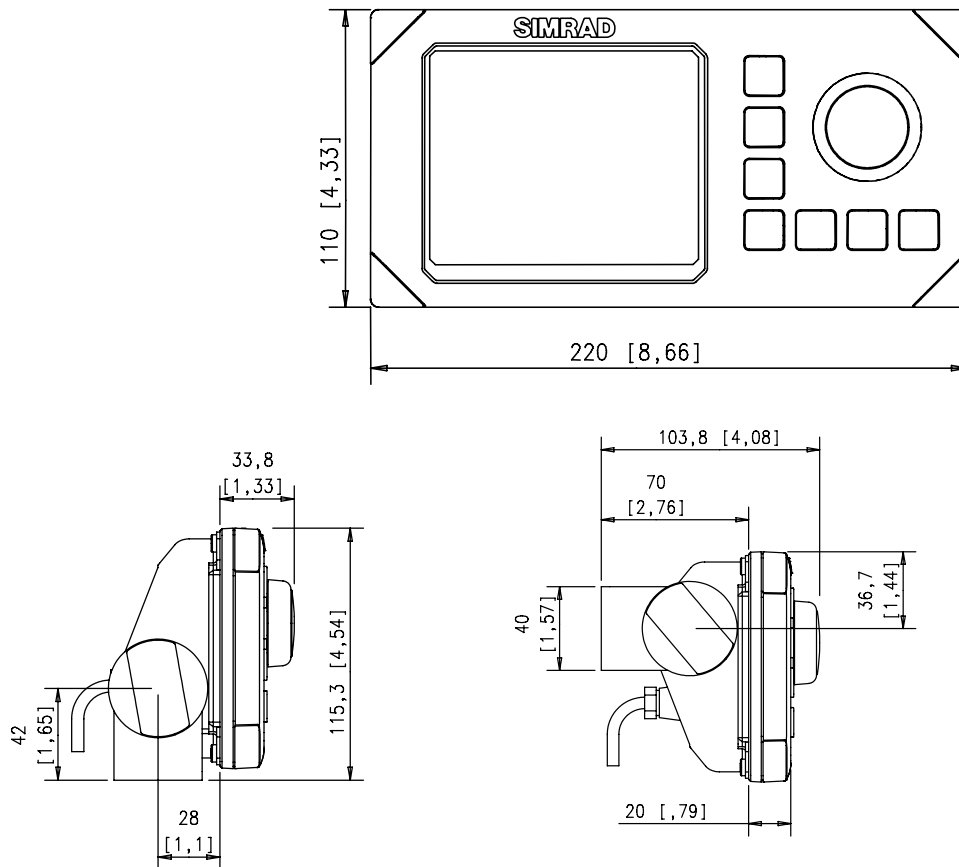

Figure 8-1 AP25 Control Unit – dimensions
(Mounting bracket is optional equipment)

8.3 Autopilot Computers

Dimensions: See Figure 8-2 and Figure 8-3

Weight:

AC10/AC20 1,3 kg (2,9 lbs.)

AC40 2,8 kg (6,2 lbs)

Supply voltage:

AC10 10-28V DC

AC20/AC40 10-40V DC

Reverse voltage protection Yes (not AC40)

Power consumption: 5 Watt (electronics)

Motor / solenoid drive:

AC10: 6 A continuous, 12 A for 5 sec.

AC20: 10 A continuous, 20 A for 5 sec.

AC40: 20 A continuous, 40 A for 5 sec.

Heading Sensor input: Composite pulse width modulated

Rudder feedback input: Frequency signal, 3400 Hz., 20 Hz/deg.

Rudder feedback units: RF300, LF3000

NMEA input/output ports: AC10: 1 (one)

AC20, AC40: 2 (two)

External Alarm: Open collector (not AC10)

Temperature range:

Operation: 0 to +55 °C (+32 to +130 °F)

Storage: -30 to +70 °C (-22 to +158 °F)

Mounting: Bulkhead mount

Material: Anodized aluminium and black ABS cover

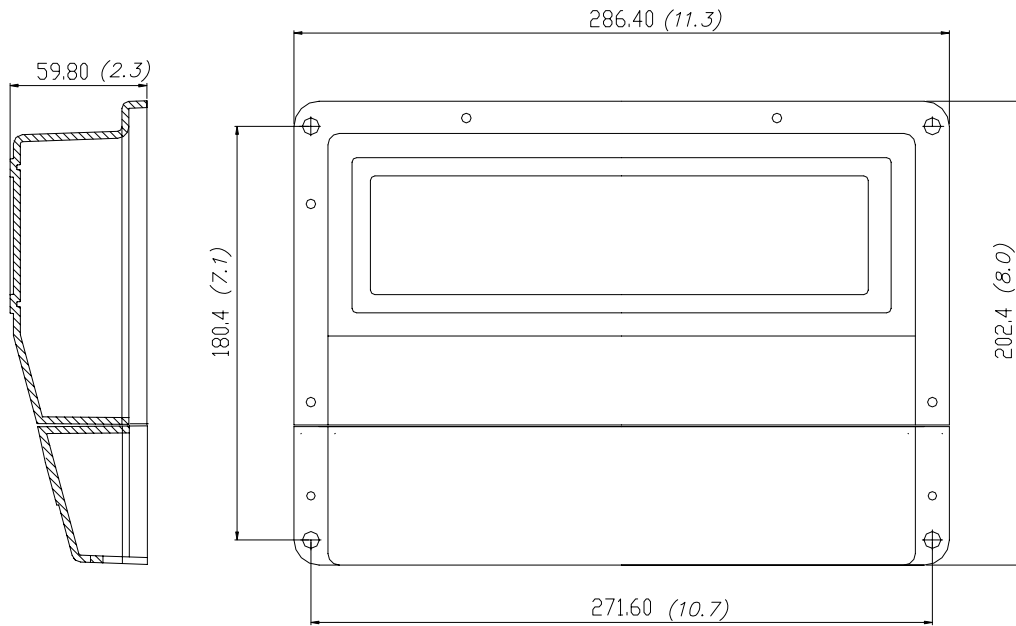

Figure 8-2 AC10/AC20 Autopilot Computert - Dimensions

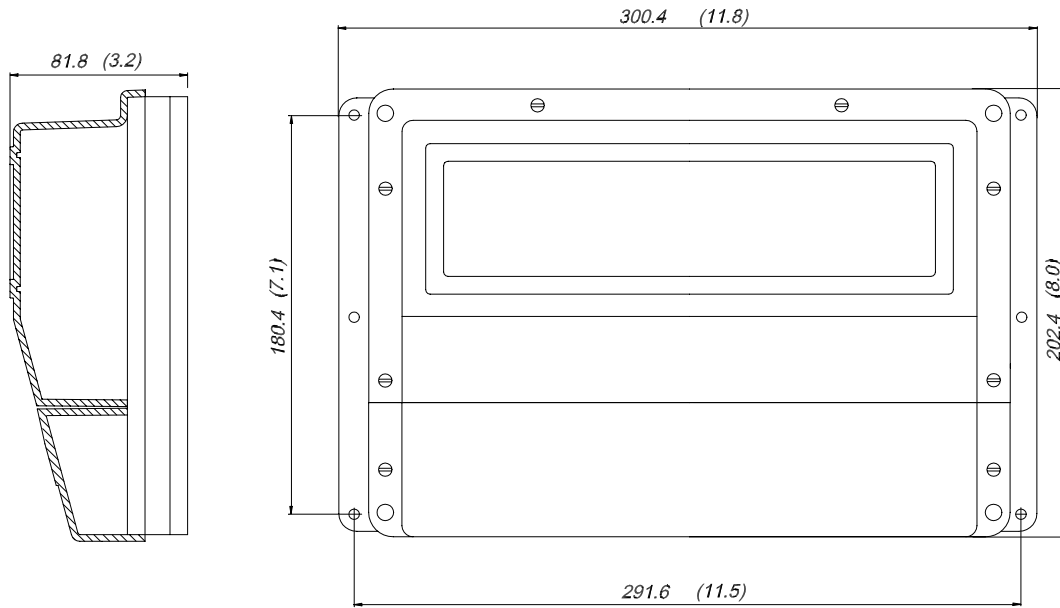

Figure 8-3 AC40 Autopilot Computer - Dimensions

8.4 RC36 Rate compass

- Dimensions: See Figure 8-4
 Weight: 0,9 kg (2,0 lbs)
 Supply and interface: RobNet2
 Power consumption: 0,9 watts
 Automatic Performance:
 Calibration: Automatically activated by control head
 Gain compensation: Automatically adjusted continuously
 Rate sensor stabilized heading output
 Accuracy: <1.25° (rms)
 Repeatability: <0.2° (rms)
 Roll/Pitch: ± 35 degrees
 Cable supplied: 15 m TP shielded cable
 Temperature range:
 Operation: 0 to +55 °C (+32 to + 130 °F)
 Storage: -30 to +70 °C (-22 to +158 °F)
 Environmental Protection: IP56
 Mounting: Deck or bulkhead
 Material: White ABS

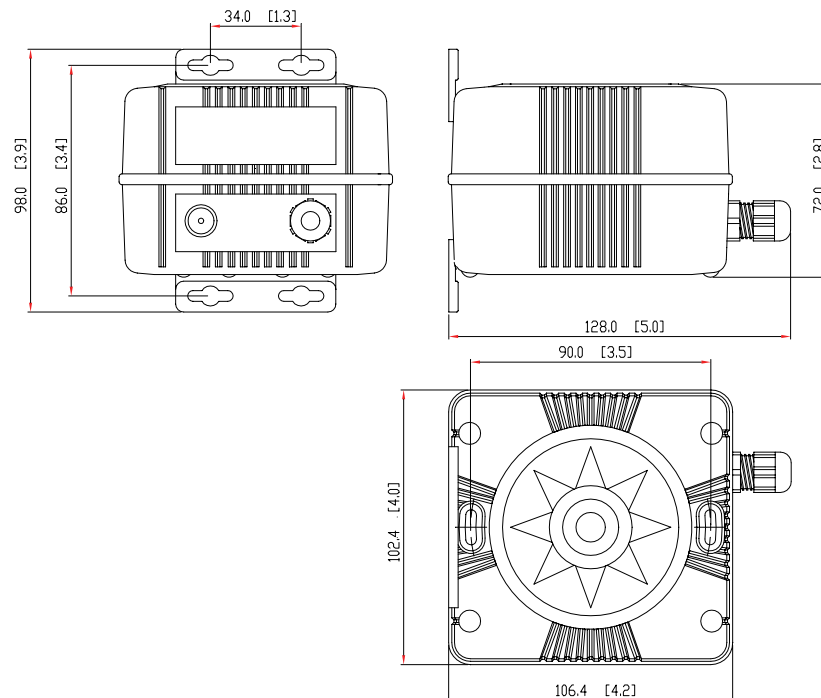

Figure 8-4 RC36 Rate Compass - Dimensions

8.5 RFC35 Fluxgate compass

Dimensions: Same as RC36. See Figure 8-4

Weight: 0,9 kg (2,0 lbs)

Supply and output: Polarity independent 2-wire supply with superimposed pulse width modulation

Automatic Performance:

Calibration: Automatically activated by control head

Gain compensation: Automatically adjusted continuously

Repeatability: ± 0.5 degrees

Roll/Pitch: ± 35 degrees

Accuracy: ± 3 degrees after calibration

Cable supplied: 15 m TP shielded cable

Temperature range:

Operation: 0 to +55 °C (+32 to + 130 °F)

Storage: -30 to +70 °C (-22 to +158 °F)

Environmental Protection: IP56

Mounting: Deck or bulkhead

Material: Black ABS

8.6 RF300 Rudder Feedback

Dimensions: See Figure 8-5 and Figure 8-6.

Weight: 0,5 kg (1,1 lbs)

Material: Arnite T06 200 PBT

Environmental Protection: IP56

Temperature range:

Operation: -25 to +55 °C (-13 to +130 °F)

Storage: -30 to +70 °C (-22 to + 158 °F)

Mounting: Horizontal, vertical, or upside down

Cable supplied: 10 m (33 ft.) twisted pair shielded cable

Rudder angle: ± 90 degrees

Output signal: Polarity independent two wire frequency signal

Frequency resolution: Centre: 3400 Hz, 20 Hz/degree of change

Linearity: ± 3 degrees up to 45 degrees of rudder

Transmission link: Stainless 350mm (13.8") with 2 ball joints.
 Ball joint stud for rudder arm requires 4.2mm diameter hole and 5mm tap.

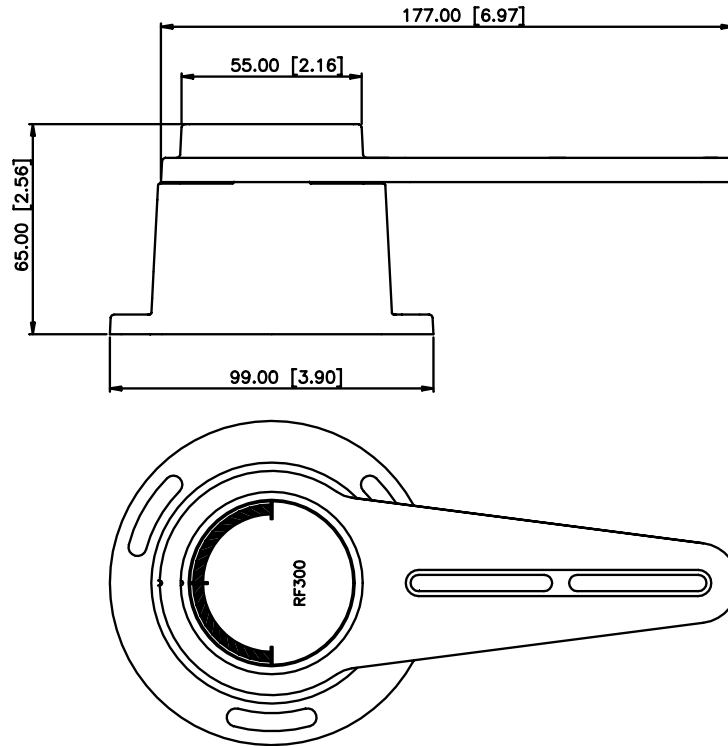

Figure 8-5 RF300 Rudder Feedback - Dimensions

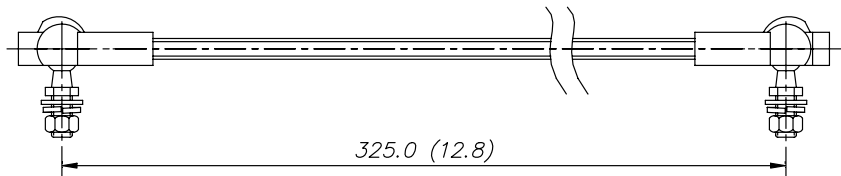
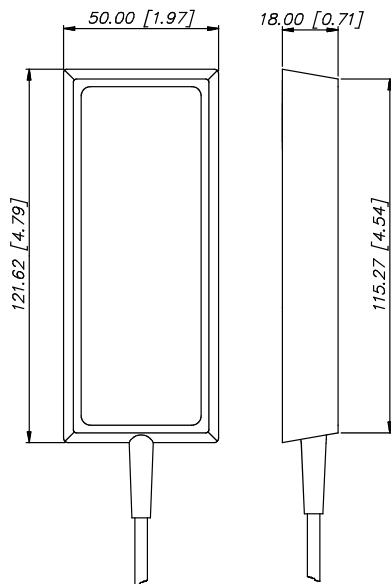

Figure 8-6 Transmission link - Dimensions

8.7 R3000X Remote Control



Dimensions: See Figure 8-7
 Weight:..... 0,4 kg (0,9 lbs)
 Material:..... Epoxy coated aluminium
 Protection IP56
 Safe distance to compass: 0.15 m (0.5 ft.)
 Temperature range:
 Operation: ...-25 to +55 °C (-13 to +130 °F)
 Storage:-30 to +70 °C (-22 to + 158 °F)
 Cable length: ... 7 m, shielded
 Mounting bracket:..... Supplied

Figure 8-7 R3000X - Dimensions

8.8 JS10 Joystick

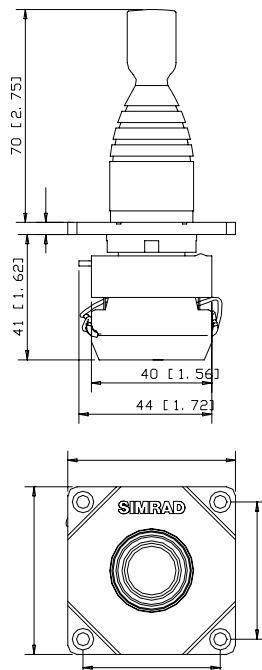

Dimensions: See Figure 8-8
 Weight:0.5 kg (1.1 lbs.)

Environmental Protection:

Joystick..... IP66

Terminals..... IP20

Safe distance to compass:..... 0.15 m (0.5 ft.)

Shock resistance (according to MIL 202 B method 202 A):

1/2 sinusoid 11 ms:

No damage or disassembling at 100 g

Vibration resistance (according to IEC 68-2-6):

16 g with frequency range from 40 to 500 Hz and maximum shifting 0,75 mm (peak -to- peak)

Temperature range:

Operation:-25 to +70°C (-13 to +158°F)

Storage:-40 to +70°C (-40 to +158°F)

Mounting: Panel-mount

Cable: 10 meters (33 ft.)

Figure 8-8
 JS10 Joystick
 Dimensions

8.9 FU25 Steering Lever

Dimensions: See Figure 8-9

Handle can be mounted pointing upwards or downwards.

Weight: 1.2 kg (2.6 lbs.) including cable

Material:..... Polyacetal (POM)

Environmental Protection:..... IP56

Power consumption: 3W

Safe distance to compass: 0.15 m (0.5 ft.)

Temperature:

Operating: -25 to +55°C (-13 to +130°F)

Storage: -30 to +70°C (-22 to +158°F)

Cable:..... 10 m (33 ft.) cable with three twisted pairs of wire run through a cable gland.
 (cable gland can alternatively be mounted on back cover; see Figure 8-9)

Max. rudder command angle:.... Equal to physical stop minus 2°

Autopilot interface:..... Via proprietary Robnet2™ bus

Accuracy:..... ±1° within ±40° of mid-position at 25°C

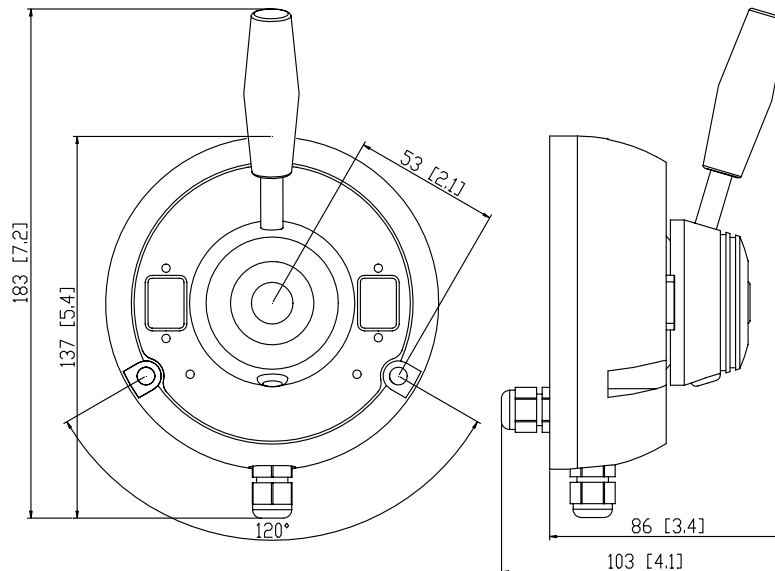

Figure 8-9 FU25 Steering Lever Dimensions

8.10 IS15 Rudder

Dimensions:	See Figure 8-9
Weight:	225 grams
Environmental Protection:	IP56 from front, IP44 from rear
Power requirement:	12/24 VDC, 70 mA (100 mA max with max lighting)
Safe distance to compass:	0.15 m (0.5 ft.)
Temperature: Operating:	-0 to +55°C (+32 to +130°F)
Storage:	-30 to +70°C (-22 to +158°F)
Scale:	Full deflection adjustable for any h.o. angle between ±20° and ±45°. Divisions: Marking per each 1/8 of full deflection. Accuracy: ±2° of full scale deflection.
Heading Display (Digital):	0 to 359°
Heading Resolution:	1°
Heading reference:	True or Magnetic North
Heading Lock:	Course and direction to steer on digital display
Course to Steer:	Settable on digital display
Display Backlighting:	Green color with seven levels plus Off
Display Backlighting Control:	Two independent lighting banks or individual settings (bank 0)
Inputs: Rudder Angle:	2-wire p.w.m. NMEA 0183, RSA Roblink (IS15 system)
Compass heading:	NMEA 0183, HDG, HDM, HDT
Outputs: Rudder Angle:	NMEA 0183, RSA, 5 Hz*
Compass heading:	NMEA 0183, HDG
Other:	NMEA 0183 sentences according to IS15 NMEA in/out table.

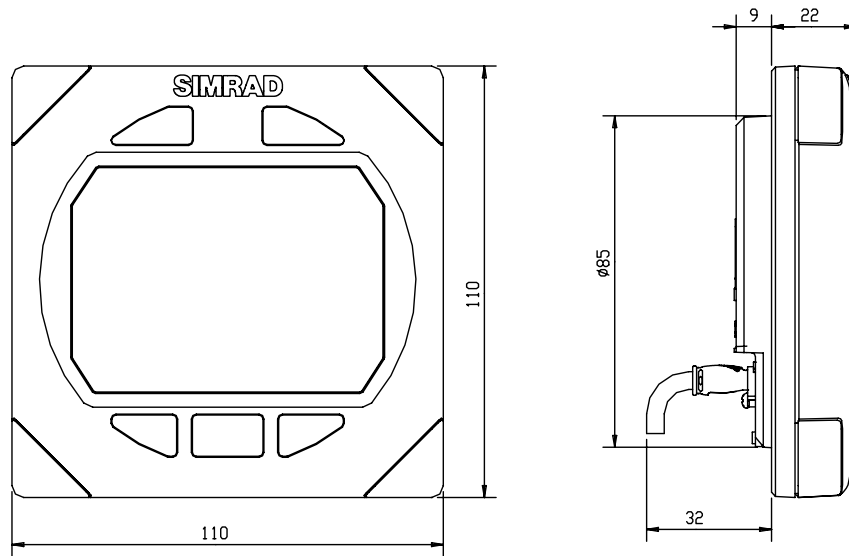

Figure 8-10 IS15 Rudder - Dimensions

8.11 SimNet

Maximum number of products connected in a network:.....	50
Maximum cable length:.....	120 m (400')
Bit rate of the bus:	250 Kbit/second
Maximum DC current through a single SimNet plug	5A
SimNet power supply:	12VDC
Maximum drop cable length:.....	6 m (20')
Maximum total length of all drop cables (accumulated):.....	60 m (200')
Environmental protection: Cable and plug/connector system.....	IP66
Temperature:.....	70°C (158°F)

8.12 IP protection

Each part of a Simrad autopilot system has a two digits IP protection code.

The IP rating is a method to classify the degree of protection against solid objects, water ingress and impact afforded by electrical equipment and enclosures. The system is recognised in most European countries and is set out in a number of British and European standards.

The first code number describes the protection against solid objects, and the second number describes the protection against liquids.

FIRST NUMBER Protection against solid objects	SECOND NUMBER Protection against liquids
IP TESTS	IP TESTS
0 No protection	0 No protection
1 Protection against solid objects up to 50 mm, eg. accidental touch by hands.	1 Protected against vertically falling drops of water (eg. condensation).
2 Protection against solid objects up to 12 mm, eg. fingers.	2 Protected against direct sprays of water up to 15° from the vertical.
3 Protection against solid objects over 2.5 mm (tools + wires)	3 Protected against sprays to 60° from the vertical.
4 Protection against solid objects over 1 mm (tools + wires + small wires)	4 Protected against water sprayed from any direction.
5 Protection against dust - limited ingress (no harmful deposit)	5 Protected against low pressure jets of water from all directions - limited ingress permitted.
6 Totally protected against dust	6 Protected against strong jets of water, eg. for use on shipdecks - limited ingress permitted.
	7 Protected against the effects of immersion between 15 cm and 1 m.
	8 Protected against long periods of immersion under pressure.

8.13 NMEA and SimNet messages

NMEA0183 messages and data overview for AC10, AC20, AC40																	
Message ident.		HDG	HDM	HDT	RSA	MWV ²⁾	VPW ²⁾	DBT	DPT	MTW	VHW ²⁾	VLW	VBW	GGA	GLL	RMA	
Data source: (n/p/h=nav/pos/heading source, c=calculated):		h	h	h	c										p	p	p
Accept. cond. (N=nav. flag, P= pos. flag):															P	P	P
	Status flag														P*	P	P
Compass_Data	Compass heading, M ¹⁾	2	1														
	Compass heading, T			3													
Rudder_Data	Rudder angle				1												
Wind_Data	Apparent wind angle ¹⁾					1											
	Apparent wind speed ¹⁾					1											
	True wind angle					1											
	True wind speed					1											
	Velocity made good to windward ¹⁾³⁾						1										
Depth_Data	Depth ref transducer							1	2								
	Transducer-Keel Offset								1								
Speed_Temp_Data	Speed through water ¹⁾										1		2				
	Log distance and trip											1					
	Water temperature									1							
Gps_Data	Present position Lat, Lon ¹⁾													4	1	2	
	COG, T																1
	COG, M ¹⁾																
	Magnetic variation	1															5
	SOG ¹⁾																1
Nav_Data	To-wp position ¹⁾																
	To-wp ident.																
	Bearing wp-wp, T																
	Bearing wp-wp, M ¹⁾																
	Bearing pos-wp, T																
	Bearing pos-wp, M ¹⁾																
	Distance pos-wp ¹⁾																
	XTE ¹⁾																
	Waypoint closure velocity ¹⁾																
Steering_contr1	Heading steering cmd, T / M																
AC NMEA-1 Rx:						x	x	x	x	x	x	x	x	x	x	x	x
AC NMEA-2 Rx:		x	x	x		x	x	x	x	x	x	x	x	x	x	x	x
AC NMEA-1 TX:	Transmission interval in sec.->	1	1	1	1												2
AC NMEA-2 TX:		.1*	1	.1*	.2												

- 1) Information required to operate in WIND_N mode
- 2) Recommended sentences for operating in WIND_N mode
- 3) If the VPW sentence is not available, the autopilot will calculate the VMG internally.

RMC ²⁾	VTG ²⁾	APB ²⁾	BOD	BWW	BWC	BWR	RMB ²⁾	XTE	HSC	Indata use				OutACXX	Remarks:
P	P	N	N	N	N	N	N	N	c	AP16	AP25	AP26	AP27		
P	P*	N	N	N	N*	N*	N	N							
P		N					N	N							* Pos flag or NMEA version 3.01 N/P=nav/pos data warning, *DGPS if flag=2
										d	d	d	d	x	
										d	d	d	d		
										d	d	d	d	x	
										d	d	d	d		
										d	d	d	d		
										d	d	d	d		
										d	d	d	d		
										d	d	d	d		
3										d	d	d	d	x	
2	3									d	d	d	d	x	
1										d	d	d	d	x	
6	4	3	2							d	d	d	d	x	
2	3									d	d	d	d	x	
					2	1	3			d	d	d	d	x	
		6	5	1	3	2	4			d	d	d	d	x	
		3	2	1						d	d	d	d	x	
		3	2	1						d	d	d	d	x	
		4			2	1	3			d	d	d	d	x	
		4			2	1	3*			d	d	d	d	x	* Only if Magnetic variation is present
					2	1	3			d	d	d	d	x	
		3					1	2		d	d	d	d	x	
							1			d	d	d	d	x	
														x	
x	x	x	x	x	x	x	x	x							
x	x	x	x	x	x	x	x	x							
2	2			10	10		2	5	10						
									10						
									10						* HDG out if magn. sensor, HDT out if true sensor

SimNet/NMEA2000 messages and data overview		127250	127245	130306	128267	130310 130311	128259	128275	65408*	129025	129029	129026	130577	128259	127258	127250	
Message ident.																	
Data source: N=nav, P=pos, H=heading, D=depth, Wa=Wind apparent, Wt=Wind True, WaS=Water Speed/ WaT=Water temp, DI=Distance log, C=Calculated):		H	C	Wa / Wt	D	WaT WaT	WaS	DI	DI	P	P	P	P	P	P	P	
Compass Data	Compass heading ¹⁾	1															
Rudder Data	Rudder angle																
Wind Data	Apparent wind angle ¹⁾ Apparent wind speed ¹⁾ True wind angle True wind speed			1 1 1 1													
Depth Data	Depth ref transducer Transducer-Keel Offset				1 1												
Speed Data	Speed through water ¹⁾						1										
Distance Log Data	Log distance and trip							1	1								
Temperature Data	Water temperature					1	2										
Position Data	Present position Lat, Lon ¹⁾ COG ¹⁾ Magnetic variation SOG ¹⁾									2	1		2	1		2	1
Navigation Data	To-wp position ¹⁾ To-wp ident. Bearing wp-wp ¹⁾ Bearing pos-wp ¹⁾ Distance pos-wp ¹⁾ XTE ¹⁾ Waypoint closure velocity ¹⁾																
Steering Data	Heading steering cmd, T / M																
APXX Gateway		x*	x	x*	x*	x* x*	x*	x*	x*	x*	x*						

Additional PGNs supported

Simrad Proprietary

- 61184 Parameter Command
- 65480 Parameter Reply
- 130840 DataUserGroup Configuration
- 65323 DataUserGroup Request

NMEA2000

- 59392 ISO acknowledge
- 60928 ISO Address claim

1) Information required to operate in WIND_N mode.

9 GLOSSARY

Apparent wind – The speed and direction from which the wind appears to blow with reference to the bow when the boat is moving (also called relative wind).

Arrival alarm – An alarm signal issued by a GPS/chartplotter that indicates arrival at or at a predetermined distance from a waypoint. (see arrival circle).

Arrival circle – An artificial boundary placed around the destination waypoint of the present navigation leg, the entering of which will signal an arrival alarm.

Bearing – The horizontal direction of one terrestrial point from another, expressed as the angular distance from a reference direction, usually measured from 000° at the reference direction clockwise through 359°.

BPW – Bearing to a specified waypoint from present position.

BWW – Bearing waypoint to waypoint - Bearing angle of the line between the “TO” and the “FROM” waypoint, calculated at the “FROM” waypoint for any two arbitrary waypoints.

COG - Course Over Ground - The actual direction of progress of a vessel, between two points, with respect to the surface of the earth, The vessel’s heading may differ from the course over ground due to the effects of wind, tide, currents.

GPS - Global Positioning System - This system is based on satellites in fixed orbits, circling the earth at an altitude of approximately 20,200 km. The system will provide the user with 24 hour a day all weather position coverage, with an accuracy of 5 to 30 meters.

Magnetic bearing – Bearing relative to magnetic north; compass bearing corrected for deviation.

Magnetic deviation – A local magnetic field onboard a vessel. Can interfere with the earth’s magnetic field and create compass readings that may deviate from the actual magnetic heading. The deviation will vary with the actual heading.

Magnetic heading – heading relative to magnetic north.

Magnetic variation - A magnetic compass points to the magnetic north pole. The difference between this direction and true north is the magnetic variation. The amount and direction of this variation is dependent upon where on the earth you are located.

NMEA0183 - A format (language) designed to permit communication between various types of marine electronic equipment. In essence this is a two-wire shielded, serial data link, permitting one device to talk while other devices listen. Numerous different sentences are available, permitting communication between various different devices.

NMEA2000 – A modern serial-data communications network to interconnect marine electronic equipment onboard vessels. Equipment designed to this standard will have the ability to share data, including commands and status, with other compatible equipment over a single signalling channel.

Product ID – A number, suffix, acronym or term that can identify a product.

Product name – The name of a Simrad product known from sales and other literature.

Route - A stored sequence of waypoints. These waypoints will be listed in the order in which you desire to follow them.

SimNet Source – Any product or device directly connected to SimNet or NMEA2000, or interfaced to SimNet via NMEA0183 or Robnet2.

Simrad Group – A number of Simrad products that are selecting and sharing the same data sources via the SimNet network.

Simrad Class 1 products – Simrad products that are SimNet controllers, i.e. they have an appropriate display and routines that can set up and control the SimNet.

Simrad Class 2 products – Simrad products that do not contain a SimNet controller. When connected to SimNet they will automatically pick the first available source on SimNet and lock on to that. When a Class 1 product is added to the Simrad Group, Class 2 products will automatically subordinate themselves to the Class 1 source selection.

SOG - Speed over ground is the actual speed of the vessel relative to the ocean floor.

True bearing – Bearing relative to true north; compass bearing corrected for compass error.

True heading – Heading relative to true north (the meridian).

Waypoint - A discrete point, stored in a navigator, located on the surface of the earth. Normally this point will be identified by Lat/Lon coordinates although in some systems it may be shown by T.D.'s.

XTE - Cross Track Error - Used to identify a vessels position relative to a straight line drawn between two waypoints. The amount the vessel is off to the left or to the right of this line is known as the track. It is normally displayed in thousands of a nautical mile, equal to 6 ft or 1.85 m.

10 INDEX

A

alarm
 external, 93
 listing, 139
apparent wind, 42, 47, 164
arrival circle, 39
auto source update, 53
automatic tuning, 121
autopilot computer
 installation, 69
 maintenance, 135
autotrim, 128

B

backlight, 50
boat type, 100
BPW, 38, 47, 164

C

cable
 Robnet, 77
 specifications, 70
compass
 calibration, 116
 maintenance, 135
 offset, 118
 selection, 54
contrast, 55
control unit
 front panel, 16
 installation, 76
 maintenance, 135
 specifications, 149
counter rudder, 56
 setting, 127
course adjust, 55
course detector interface
 specifications, 152
course knob icon, 50
course over ground, 47

course to steer, 37, 58
cross track error, 37, 47, 166
C-turn, 25, 55

D

depth offset, 121
depth source, 54
depth unit, 113
depth-turn, 30, 55
deviation, 117
display units, 113
dockside settings, 100
dodging, 32
drive engage, 105
Drive out, 104
drive unit
 hydraulic pumps, 72
 installation, 72
 linear drive, 72
 maintenance, 135
 reversible pump, 74
 solenoid valve, 75
 stern drive, 18
 voltage, 101
DTT, 47, 107

E

ETT, 47, 107

F

fluxgate compass
 installation, 80
 specifications, 153
follow-up steering, 19

G

grounding, 70
gybing, 43, 44

H

heading capture, 21

I

illumination. *See* backlight
Init NAV, 123
instrument
 installation, 91
 log, 55, 61
 main, 55, 61
 menu, 60
 motorway, 55, 61
 nav data, 55, 61
 position, 55, 61
 screen, 60
 select, 55, 61
 SOG/depth, 55, 61
 speed/depth, 55, 61
 wind angle, 55, 61
 wind direction, 55, 61
 wind shift, 55, 61
interface setting, 113
interfacing, 83
IP protection code, 159

J

junction unit
 specifications, 150

L

language, 98
layline, 47, 60
lazy S-turn, 29, 55
linear feedback
 installation, 93
lock function, 48
log source, 54

M

master reset, 132
Minimum rudder, 115
minimum wind angle, 106
modes of operation
 auto, 21
 nav(igating), 37
 NoDrift, 35

standby, 16
turn, 24
wind, 41
multiple station, 48

N

NAV change limit, 124
NAV source, 50
Nav/Wind, 51
navigating, 37
navigation source, 54
NFU Steering lever, 13
NMEA compass, 12, 90
NMEA data, 129
NMEA input/output, 89
NMEA messages, 160
NMEA test, 130
NMEA0183, 165
NMEA2000, 53, 86, 165
NoDrift, 35, 50, 54
non-follow-up steering, 19

P

parameter selection
 automatic, 22
 manual, 23
position source, 54

Q

quick setup, 59

R

racing, 47, 51, 106
radar connection, 91
radar interface, 113
rate compass
 installation, 81
recall autotuned, 128
remote control
 installation, 82
 specifications, 155
response, 56
rudder, 56

- setting, 127
- rudder deadband, 105
- Rudder deadband, 131
- rudder feedback
 - calibration, 102
 - installation, 67
 - maintenance, 135
 - specifications, 153
- rudder limit, 128
- Rudder play compensation, 124
- rudder test, 103
- rudder zero, 115

S

- sea trial, 114, 132
- seastate filter, 57
- shallow water, 54, 58
- SimNet, 9, 11, 53, 83
 - backlight, 131
 - gateway, 131
 - number, 131
 - reset, 131
 - setup, 131
 - source, 131
- SimNet messages, 162
- SimNet source, 165
- Simrad group, 131
- software program exchange, 137
- software setup, 95
- source manually update, 53
- source select, 53
- specifications, 147
- spiral-turn, 26, 55
- square-turn, 28, 55
- steering lever
 - installation, 82
- system
 - basic, 10
 - components, 10
 - specifications, 147
- system data, 128

T

- tack angle, 107
- tack time, 43, 107
- tacking
 - in auto mode, 35
 - in wind mode, 43
- thrust direction, 119
- thruster, 52
- thruster interface, 13
- thruster sensitivity, 57
- Thruster steering, 33
- transition speed, 123
- trip reset, 52, 57
- true bearing, 166
- true heading, 166
- turn on, 95
- turn pattern, 55

U

- user training, 133
- U-turn, 24, 55

V

- Virtual feedback, 100, 109, 124, 125
- VMG, 47, 59, 107

W

- water speed source, 54
- water temperature source, 54
- water temperature unit, 113
- wind
 - damping, 120
 - offset, 120
- wind angle source, 54
- wind apparent, 52
- wind auto, 51
- wind calculated source, 54
- wind response, 58
- wind setup, 51, 106
- wind shift limit, 108, 109
- wind speed unit, 113
- wind true, 52

wind vane steering, 41

Z

zigzag-turn, 27, 55