

CE ORIGINAL MANUAL

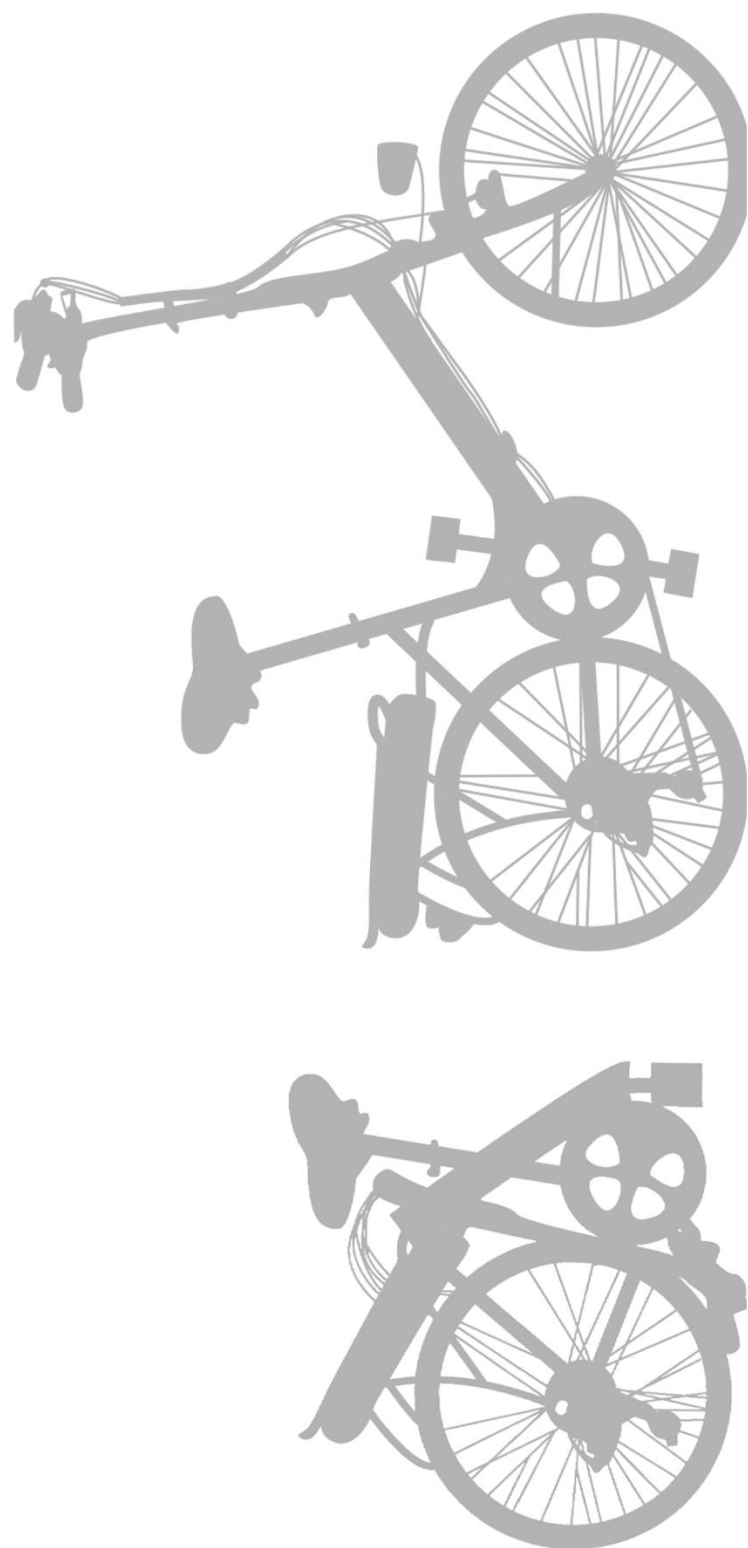

WWW.LACROS.NL

ELECTRIC (FOLDING) BIKES FROM THE NETHERLANDS
INTELLIGENT, RELIABLE AND COMFORTABLE



CE ORIGINAL MANUAL
(TRANSLATION OF THE ORIGINAL INSTRUCTIONS)

LACROS SCAMPER S600 XL

ELECTRIC FOLDING BIKE

For your safety

Your safety is very important, so read the following safety advices carefully. More safety tips are listed further in the manual:

1. The LACROS Electric bike is equipped with an electromotor. It is very important that you are familiar with the bike as soon as possible. We advise you to choose the first "practice rides" for easy roads with little traffic and a smooth road surface.
2. When you want to ride, do not stand on the pedal, but first sit on the saddle and then start pedaling.
3. Ride the first rides preferably without electrical support to get familiar with your bike. After this you can start with a low setting (motor support).
4. The LACROS bicycles have been tested by our employees. If you have any doubts about the bicycle and/or the electrical installation of the bicycle, please contact us immediately.
5. Never expose the battery and the charger directly in the sun or heat surfaces. The battery is protected against heat, but heating is better avoided.
6. Never use a charger other than the one supplied by Shinga B.V. It is very important for your safety to always use the original charger.
7. The brakes are equipped with an "ABS" protection. As a result, the support stops when you use the brakes.
8. We recommend wearing a helmet while cycling.

The LACROS bicycles are delivered in accordance with the most recent European guidelines (page 3), if you have any questions or comments, do not hesitate to contact us.

We are always available for users of LACROS bicycles:

E-mail: service@lacros.nl

Phone: +31 73 203 2487

Thank you for your trust,



Ton van den Oetelaar

Director Shinga BV

Review documentation EMC-directive: 2014/30/EU Machine directive: 2006/42/EG

Your product is an electric folding bike. The bicycle can be folded at 2 locations, on the handlebar stem and halfway at the frame. The bike is equipped with a pedal support system which is powered by an external battery. The battery can be in different locations, such as on the luggage carrier or in the frame. The battery is charged via an external charger. This external charger is a separate product and is already provided with a CE mark (for example, the Low Voltage Directive and the EMC Directive).

The input voltage of the battery is 36V, the motor has a power capacity of 250W and the maximum speed of the bike is 25 km/h.

Guidelines:

Based on the above product description, the following guidelines apply:

- EMC-directive: 2014/30/EU
- Machine directive: 2006/42/EG

The Low Voltage Directive does not apply because the input voltage is only 36V. The charger of the battery is separately marked with a CE mark.

Based on the above guidelines, a number of (corresponding) standards apply.

The following relevant documents must be mentioned in this context and are also used as input for all other documentation:

- NEN-EN 15194:2015 Cycles (Electrically power assisted cycles - EPAC Bicycles)
- NEN-EN-ISO 4210-1:2014 and
- EN ISO 12100:2010

Table of contents

For your safety	2
Review documentation EMC-directive: 2014/30/EU Machine directive: 2006/42/EG	3
1. Unfolding the bicycle	5
2. Folding the bicycle	6
3. How to operate the bicycle	7
Turn on the display	7
Turn on LED lights	7
Walk Assist	8
Additional options of the display	8
Display symbols	8
De Shifter	8
Adjusting the front fork suspension	8
4. Battery and recharging	9
Recharge advice	9
Warning	10
How to recharge the battery	10
Removing the Battery	11
5. Action radius	11
6. Safety rules	12
7. Warranty provisions and legal requirements	13
Battery warranty	13
8. Technical specifications	14
9. EC declaration	15

1. Unfolding the bicycle

Magnetic lock

Push the wheels apart to remove them from their magnetic lock.

A = metal locking plate

B = magnet

C = direction in which you can lock

D = Locked position

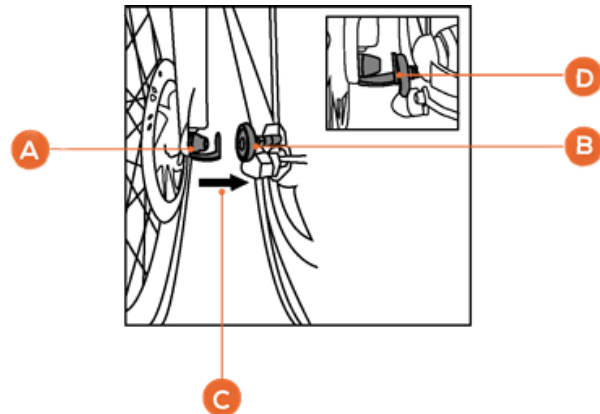

Unfolding the frame

To unfold the frame, slide the wheels apart until the frame is in a straight position. It is easy to stand on the left side of the bike.

Secure the frame clamp

Secure the frame clamp (A + B) (middle hinge mounting on the right of the frame tube) by first securing the latch with the frame and then locking the clamp by pushing the clamp against the frame. **Secure the lock with the locking clip (located just above the frame clamp) on the frame clamp.**

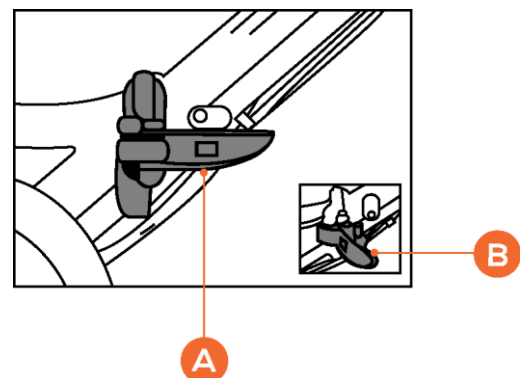

Unfolding the steering wheel and securing

Pull the handlebar (A) up and secure it with the handlebar clamp (B). Make sure that the Pin fits properly in the handlebar clamp. Secure the clamp with the locking ring by rotating towards the clamp (located on the steering column near clamp).

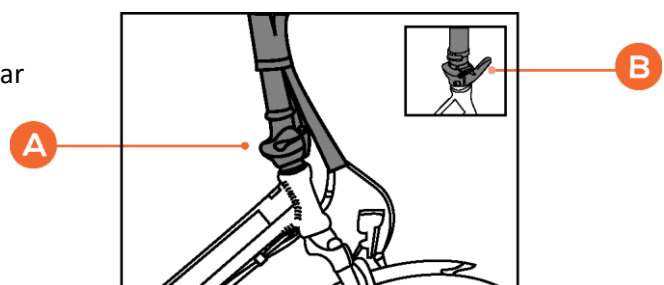

Unfold pedals

Unfold the pedals by pulling the pedal to its horizontal position. The pedal will automatically return to its correct position.

2. Folding the bicycle

Folding the pedals

Fold down the bicycle's stand and fold the pedals in by pushing the entire pedal towards the bike and then folding it up or down.

Note: Position the pedals horizontally with the left pedal forward, so that it will not get in the way when the frame is folded.

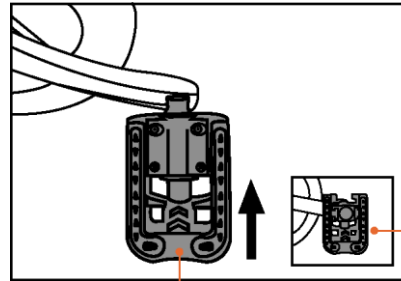

Handlebar clamp

Release the steering, first by rotating the locking ring (A) away from the clamp. Open the clamp (B) so you can fold the steering.

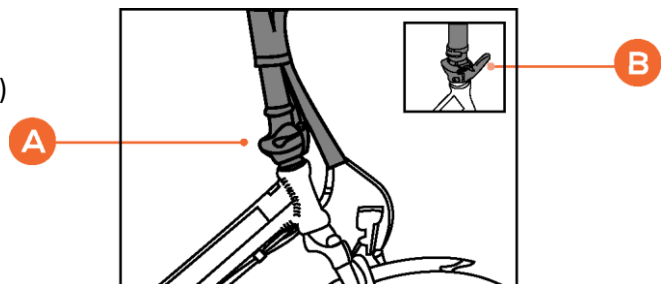

Frame clamp

Open the middle hinge mounting (right on the frame tube) by moving the locking clip upwards. Pull the clamp (A + B) outwards so that it comes loose. The frame is now open and ready to fold.

Note: Do not use excessive force to release the clamp.

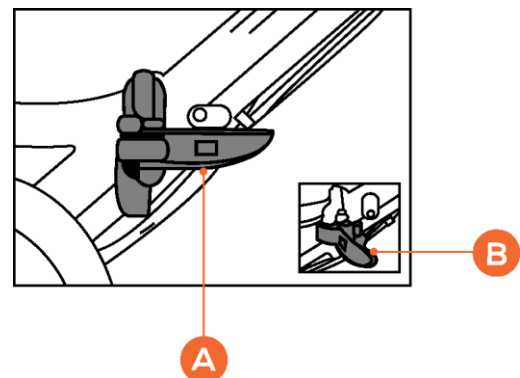

Folding the Frame

Stand to the left of the bike and fold the front wheel to the rear wheel so that the wheels are close together. Under the bottom bracket there is a triangular support on which the bicycle can rest when folded.

Securing the wheels

Secure the bicycle by placing the wheels against each other so that the magnets (A + B + D) connect each other (C). It is advisable to provide the handlebars and frame with protection during transport by means of, for example a blanket.

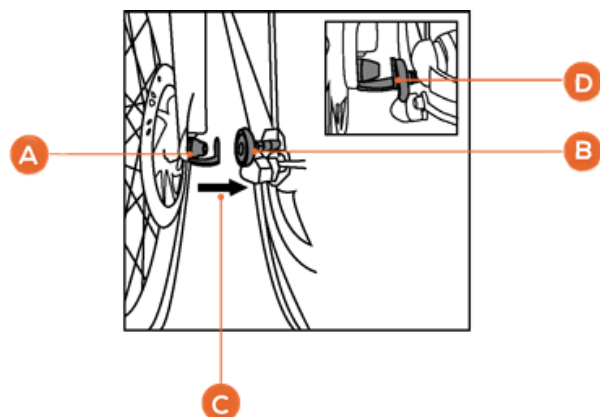

3. How to operate the bicycle

Switch on the battery and read the battery status

The battery (model 2019) is located on the luggage rack with the Scamper. Switch on the electrical system with the button on the left side of the battery (A). (Note, you only have the battery activated, the display is still off)

The number of lights indicates the battery charge. This is a rough indication of the battery charge.

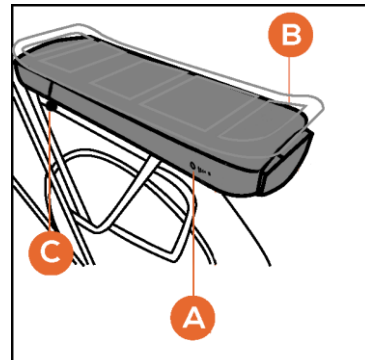

A = on/off button

B = charging point

C = lock

Turn on the display

Press (1) to turn on the bicycle electrical circuit. A menu now appears on the display, the electric circuit is switched on.

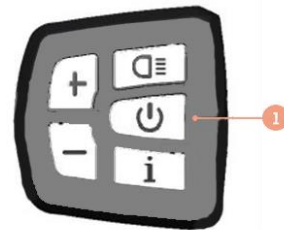

Turn on LED lights

Press (1) for ± 2 seconds to turn the lights on. A light-symbol will appear on the display. Press 2seconds to turn off lights.

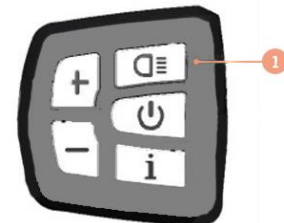

Electric motor support

With the (1) and (2) buttons you can choose from the 5 levels support modes which are shown at the bottom of the display.

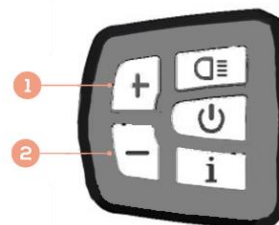

Walk Assist

Press and hold button (2) when stationary to activate the Walk Assist which provides support from 0 km/h to 6 km/h. By using button (2) while cycling, the electrical support goes directly to its maximum (25 km/h).

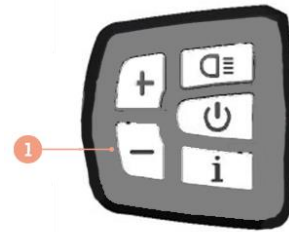

Additional options of the display

By pressing button (1) briefly in succession, you can scroll through various data:

Total Km/Miles reading (TOTAL), Trip reading (TRIP), distant km in current support RANGE) and maximum speed (MAX).

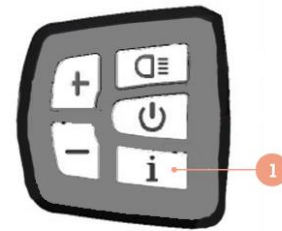

Reset Trip, Time and Maximum speed data by pressing the (a) button twice in succession. You will then arrive in the menu where the letter "n" will be displayed, then press the (+) key once, the "n" will then be replaced by an "y". Press the (a) key twice again, to return. The trip distance is now reset.

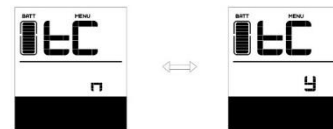

Display symbols

- a = battery indication
- b = light
- c = walk assist
- d = service notification
- e = menu
- f = Km/h indication
- g = error symbol
- h = mileage
- l = current level motor support

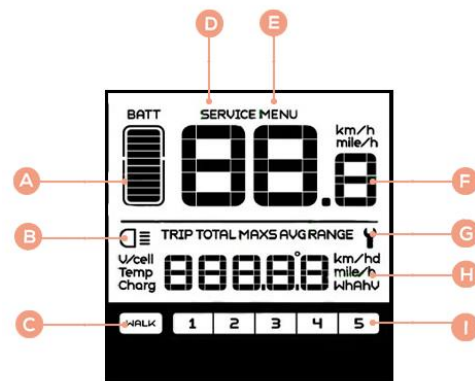

De Shifter

The shift mechanism of the hub gears is located on the steering wheel, which has a rotary switch (d) and an indicator (a). By rotating forward (d) you switch down, by rotating towards you (d) you switch up.

Note: You must stop pedaling while switching gears. You may damage your gears when pedaling during shifting gears.

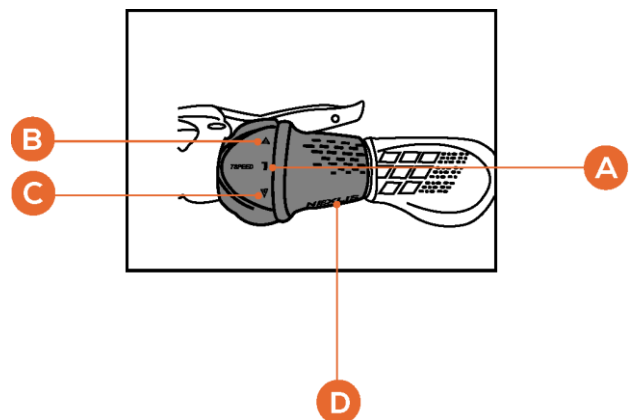

Adjusting the front fork suspension

On top of the front fork suspension on the right side is a cap on which you can turn to adjust the strength of the front fork suspension. Indicated with a plus and a minus for less and more suspension.

4. Battery and recharging

General:

- A full recharge takes approx. 4.5 - 8.5 hours. This depends on the capacity of your battery.
- The battery can be recharged both in and out of the bike.
- When replacing the battery, make sure that the contact points of the battery and the contact points of the battery compartment match properly.

Recharge advice

- Always recharge the battery with the Lacros charger supplied with the bike. Do not use any other charger.
- **The first 2 recharges of a new bicycle must be more than 60%. To realize this, wait the first 2 times before recharging, until the battery indicator on the display has fallen below 40%.**
- **Recharging will stop automatically when the battery is fully charged.** Only when the red indicator light on the charger is lit, the battery will be recharged.
- After 2 full charges (first 2 charges), the battery does not have to run to a minimum of 40% before you start recharging again. **After 2 full recharges, the battery can be recharged at all times, even after short rides.**
- **The battery remains in good condition when you recharge the bike after every use (regardless of the distance). So keep the battery as full as possible.**
- **The warranty on the battery expires if a deep discharge is detected** (this can only happen if you leave the battery on and leave it for a long time without recharging.)
- **In the case of long-term storage: fully recharge the battery, disconnect the battery from the charger and the bicycle and switch off the battery with the rocker switch. Charge the battery at least once every three months.**
- The battery performs less well below 10 °C, you will have less battery capacity.

Warning

Read the warnings below carefully.

- Do not expose the battery to fire or heat. Never put the battery in fire.
- Do not drop the battery or damage it.
- Do not immerse the battery in water or any other liquid.
- Keep the battery out of the reach of children
- Never open the battery without permission from Shinga B.V. The battery is provided with a seal.
Breaking the seal will void the warranty, unless Shinga BV gives permission.
- Do not put liquids or metal in the charger.
- Do not connect the charger to the battery with wet hands.
- Do not touch the charger in case of lightning.
- Do not use the charger in a very humid environment.
- Do not use the charger for purposes other than charging the corresponding battery.
- Ensure good ventilation at the location of the battery and charger during charging.
- Do not connect the charger to the power socket if the charger is not being used.
- Do not charge the battery in full sun.

How to recharge the battery

The battery has one charging point (A) on the right side of the battery. It is recommended to first connect the charger to the battery and then plug the 220V plug into the socket. It is better for the battery to connect it to the charger after every cycle. The charger will stop charging as soon as the battery is full. When the battery is full (when the light on the charger is green) the charger can be disconnected.

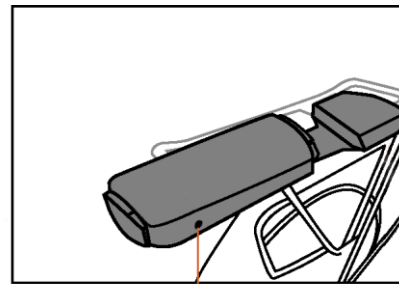

A

A = Red (Power on/Recharge)
B = Green (Power off/fully charged)

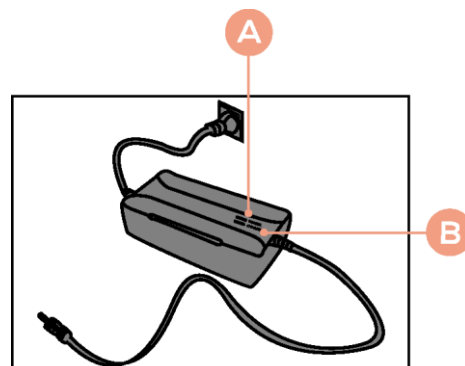

Removing the Battery

The battery can be removed from the battery box by first turning the key (1) 180 degrees to the left, and then carefully pull the battery back. Ensure that the battery is always locked when you place it back. The battery may otherwise vibrate when cycling.

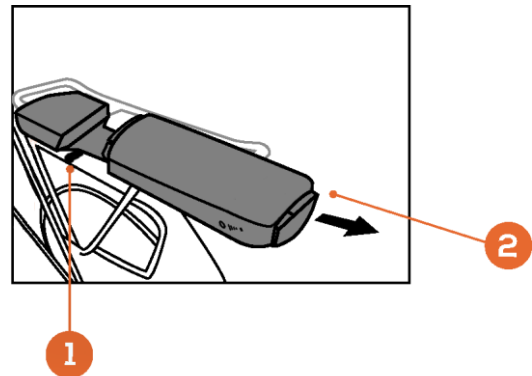

5. Action radius

The action radius represents the distance in kilometers that can be covered with a fully charged battery. The range is influenced by various factors:

- Capacity (Ah) and voltage (V) of the battery
- Motor support level
- The total carrying weight on the bicycle
- Amount of pedal force supplied by the rider
- Ambient temperature (capacity of the battery decreases below 10 °C)
- Wind force
- Tire pressure (keep this at ± 3.5 bar)
- Condition of the road surface

With aging, the battery action radius decreases.

6. Safety rules

- Read your bicycle's manual carefully before your first use.
- Follow the traffic rules strictly.
- Never dismantle the bicycle yourself. Contact your Shinga B.V supplier for the device component.
- Do not lend your bicycle to people with little experience on an electric bicycle.
- Do not ride under the influence of drugs or alcohol.
- Never load the bike exceeding its maximum capacity.
- Do not modify your vehicle yourself. As a result, the warranty and liability will expire.
- The maximum speed of the vehicle is 25 Km/h.
- If the front fork, steering column or handlebars are bent after an accident, they must never be bent back to their original position to prevent breakage. Contact your Shinga dealer or Shinga B.V directly. to have the damaged parts replaced.



Figure 1: STEER-/ SADDLE PIN

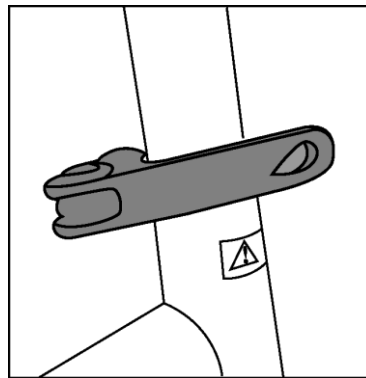

Figure 2: STEER-/ SADDLE CLAMP

- **STEER-/ SADDLE PIN:** See figure 1. A rib line is engraved in the seat post and stem. This is the minimum length that must remain in the frame (with the seat post) or in the steering column (with the handlebar post).
- **STEER-/ SADDLE CLAMP:** See figure 2. These clamps allow you to adjust the saddle and handlebar to the correct height. Make sure these clamps are tight.

7. Warranty provisions and legal requirements

Battery warranty

The supplier of your battery gives a warranty on any material and construction errors to your battery if the following conditions are met:

You can only claim the warranty if you can show a warranty or proof of purchase. The warranty period starts on the day of delivery. The guarantee expires if depth discharge has been determined on the battery.

The manufacturer is not responsible for accidents or malfunctions in the battery caused by the use of the battery which is against the advice of Shinga B.V. or its dealers.

E-bike warranty period

We provide a 2-year manufacturer's warranty on all running bicycle parts of your new bicycle. The electrical components of your e-bike (display, motor and battery) also have a 2-year manufacturer's warranty. Excluded from the guarantee are parts that show normal wear and tear, including (inner) tires, saddle, cables and lighting. It is therefore important to properly maintain your bicycle and regularly check it for wear. You also have a 10-year manufacturer's warranty on the frame.

Do not clean the bike with a high-pressure cleaner. A powerful jet of water can damage the electronics. The warranty then expires.

Legal requirements

According to European legislation, the vehicle described is a bicycle because the vehicle complies with the following rules:

- From 6 Km/h, the support is only active when the user is pedaling.
- The support is active up to a maximum of 25 Km/h.
- The power supplied is a maximum of 250 watts.

According to Dutch law, the vehicle described is a bicycle because the vehicle has the following components:

- Two independent, well-functioning brakes.
- Headlight with white or yellow light & rear light with red light and a reflector.
- Wheel reflector and/or reflective tires and/or reflective rims.
- Pedals with yellow reflectors.

Environment

In accordance with the environmental regulations for the collection and processing of batteries from the Ministry of Housing, Spatial Planning and the Environment, we recommend that you always return it to your dealer or Shinga B.V in the event of a battery defect. This is required to take the battery and takes care of the further processing of the battery.

Periodic maintenance and malfunctions

Your e-bike needs regular maintenance. Shinga B.V. or your dealer can advise you on the optimal use and maintenance of your e-bike. If you have questions or problems with your e-bike, please contact your dealer or Shinga B.V.

8. Technical specifications

- Dimensions folded out (LxWxH): 173x66x128cm
- Dimensions folded (LxWxH): 90x45x80cm
- Frame: Aluminum
- Motor type: Bafang M400 midmotor
- Motor voltage: 36V
- Motor power: 250W
- Sensor: Pedal force sensor + magnetic rotation sensor
- Battery type: Lithium-Ion polymer (heat-resistant cells)
- Battery specifications: 36V 13Ah / 17.5Ah
- Action radius: 40-80km (13Ah)
- Motor support: 5 levels
- Gears: Shimano 7 hub gears
- Maximum carrying load: 130 Kgs
- Gross weight: 25 Kgs
- Net weight (without battery and saddle): 22.5 Kgs
- Wheel diameter: 24 inches
- Maximum speed: 25 Km/h (support stops at a speed > 25 Km/h)

Maintenance

We recommend the first service of your bicycle after 1000 km. After this we recommend every 2500 Km or once per year. To extend the life of your bike, we recommend that you keep the chain and the derailleur clean and lubricate your chain with chain oil once every 3 months.

The valves

The tires are equipped with a Blitz valve (formerly Dunlop valve) which can be inflated with a standard bicycle pump. A reducer fits on this valve to go from a bicycle valve to a car valve.

Frame number

The frame number is located at the front of the frame. This is stamped in the paint just above the front fork suspension.

9. EC declaration

Supplier:	Technical Files:	Manufacturer:
SHINGA B.V. MOLENDIJK ZUID 23B 5482 WZ SCHIJNDEL THE NETHERLANDS	VAN DEN OETELAAR (SHINGA B.V.) MOLENDIJK ZUID 23B 5482 WZ SCHIJNDEL THE NETHERLANDS	SHINGA B.V. MOLENDIJK ZUID 23B 5482 WZ SCHIJNDEL THE NETHERLANDS

Product: Electric folding bike

Model: JSL 039Z

Name: Lacros Scamper S600XL

THIS E-BIKE IS MANUFACTURED ACCORDING AND IN APPLIANCE WITH EUROPEAN UNION GUIDELINES AND REGULATIONS CONCERNING ELECTRIC BIKES WITH A MAXIMUM SPEED OF 25 KM/HOUR AND A MAXIMUM MOTOR OUTPUT OF 250W

THE FOLLOWING "EN" (ISO) STANDARDS APPLY:

EN ISO 12100:2010; EN 15194:2009; EN 14764:2005; EN 349:1993+A1:2008; EN 953:1997+A1:2009; EN 13857:2008

EU GUIDELINES APPROVAL:

2006/42/EC MACHINERY DIRECTIVE; 2006/95/EC LOW VOLTAGE DIRECTIVE; 2004/108/EC ELECTROMAGNETIC COMPATIBILITY DIRECTIVE

ELECTROMAGNETIC COMPATIBILITY DIRECTIVE (2014/30/EU), MACHINE DIRECTIVE (2006/42/EC)

EC EXECUTIVE BODY CERTIFICATION: ENTE CERTIFICAZIONE MACHINE S.R.L., VIA MINCIO 386, 41056 SAVIGNANO, ITALY; NOTIFIED BODY EC TYPE OF RESEARCH NUMBER: 1282

CERTIFICATE NUMBER: 111123/ZJV845

CERTIFICATE DATE: NOVEMBER 2011