

SB
S M O K E Y
B A N D I T
S I N C E ★ 2 0 1 7

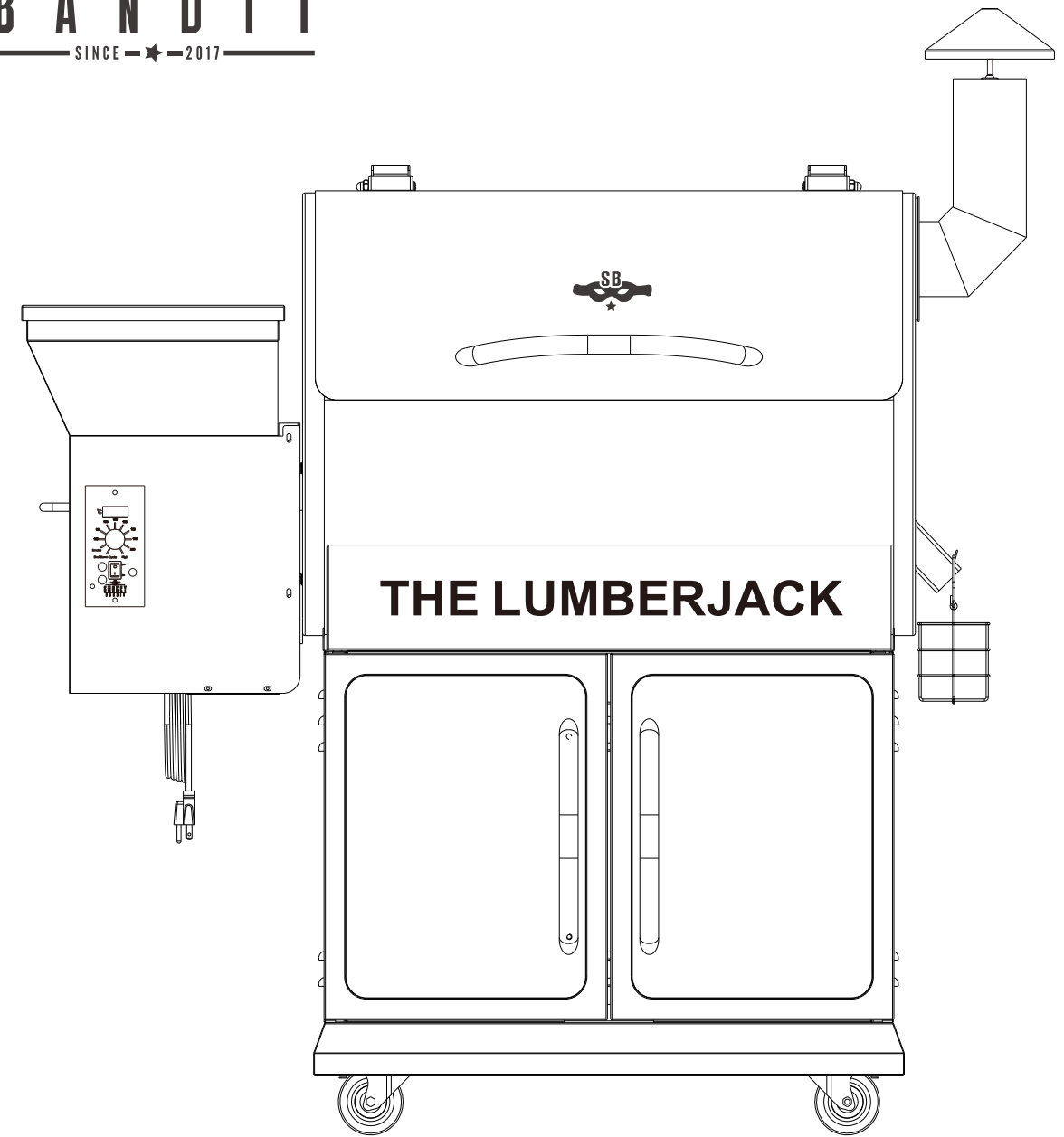

THE LUMBERJACK

SBTL - 2017

Instruction Manual

TO CUSTOMERS

FOR OUTDOOR USE ONLY!

Please read this entire manual before assembly, installation of your Smokey Bandit Pellet Grill. Failure to follow these instructions could result in property damage, bodily injury or even death. Contact your local building or fire official about restrictions and installation inspection requirements in your area.

A MAJOR CAUSE OF FIRES IS FAILURE TO MAINTAIN REQUIRED CLEARANCES (AIR SPACES) TO COMBUSTIBLES MATERIALS. IT IS OF UTMOST IMPORTANCE THAT THIS PRODUCT BE INSTALLED ONLY IN ACCORDANCE WITH THESE INSTRUCTIONS.

SAVE THESE INSTRUCTIONS FOR FUTURE USE!

IMPORTANCE

⚠ DANGER!

- Hazardous voltage is present which can shock, burn or cause death. Disconnect the power cord before servicing the Grill unless otherwise noted in the Owner's Manual.
- Never use or store flammable liquids near the Grill.
- Never use gasoline or lighter fluid to manually light your Grill. Use **ONLY** Alcohol Gel for this procedure **AND** according to the instructions in the Owner's Manual.

⚠ WARNING!

- When operating this Grill, maintain a **MINIMUM** distance of 12" from the Grill to combustibles.
- When operating this Grill under overhead combustibles a **MINIMUM** of 40 inches is required.

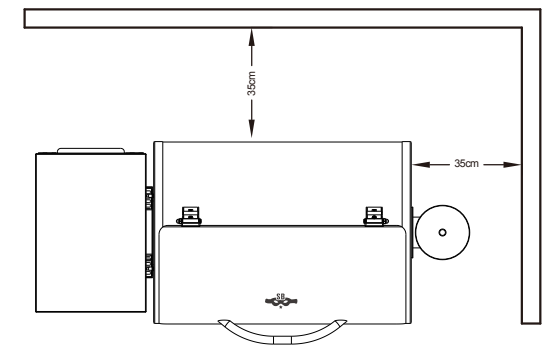
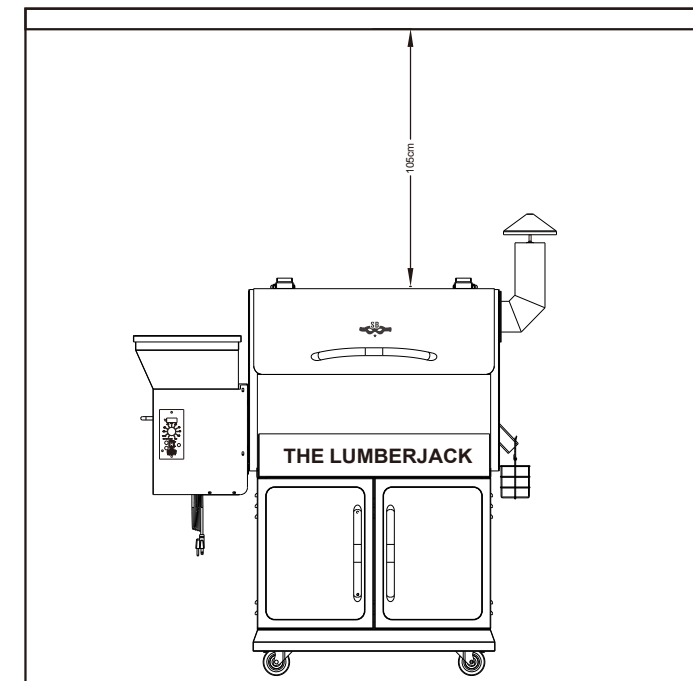

- Assemble and operate this Grill **ONLY** per the instructions in this Owner's Manual.
- This Grill is intended for **OUTDOOR USE ONLY**.
- Never use heating fuel pellets in the Grill, due to potential hazardous contaminants and additives that may be present.

⚠ CAUTION!

- Always store wood pellets in a dry location, away from heat-producing appliances and other fuel containers.
- Keep the Grill clean – See the cleaning Instructions in this Owner's Manual.
- Do not use accessories not specified for use with this Grill may be present.

COMPONENT LIST

ITEM	Qty	Description
1	1	Grill Chamber Assembly
2	1	Thermal Baffle
3	1	Hopper Bottom Cover
4	1	Body Frame
5	1	Heat Baffle
6	1	Grease Drain Pan
7	1	Warming Rack
8	1	Porcelain Grills
9	1	Lid
10	2	Hinge Assy
11	2	Pivot
12	1	Lid Handle
13	1	RTD
14	1	Chimney Cap Assembly
15	1	Smoke Stack Assembly
16	1	Smoke Stack Gasket
17	1	Grease Basket
18	1	Screwdriver
19	1	Hopper Burner Lid
20	1	Hopper Burner Handle
21	1	Hopper Guard
22	1	Digital Control W/SDC
23	1	Hopper Assembly
24	1	Hopper Bottom Cover
25	1	Auger Drive Motor
26	1	Auger Tube Bushing
27	1	Power Cord
28	1	(3/8 x 3/16) Thick Gasket
29	1	Power Cord Collector
30	1	Auger
31	1	Hot Rod (Ignitor)

ITEM	Qty	Description
32	1	Firepot Assembly
33	1	Burner Box Assembly
34	1	Hopper Burner Gasket
35	1	Hopper Burner Assembly
36	1	Fan
37	2	Bottom Pivot
38	1	Left Door
39	1	Left Door upper Pivot
40	1	Left Plate
41	1	Magnet Block
42	1	Beam
43	4	Magnet
44	1	Back Board
45	1	Right Plate
46	1	Right Door
47	2	Door Handle
48	2	Wheels(without brake)
49	2	Wheels(with brake)
50	1	Platform
51	2	Cap Nuts
52	19	Bolt 1/4-20*12mm
53	8	Hexagon Bolt 1/4-20*12mm
54	8	Gasket (Ø18*Ø6.5*2.0mm)
55	2	Hexagon Nut 1/4-20
56	1	Right Door Pivot
57	2	Gasket (Ø12*Ø4.2*1.0mm)
58	2	Bolt 5/32-32*5mm
59	2	Wrench
60	4	Bolt 5/32-32*6 mm
61	1	Hopper Assembly I
62	1	Hopper Assembly II
63	4	Kep Nut 5/32-32

Remark: 52*(Screw package) has 19 screws in total, including 18 necessary screw and 1 spare screw.

SECTION 1 : ASSEMBLY INSTRUCTIONS

List :

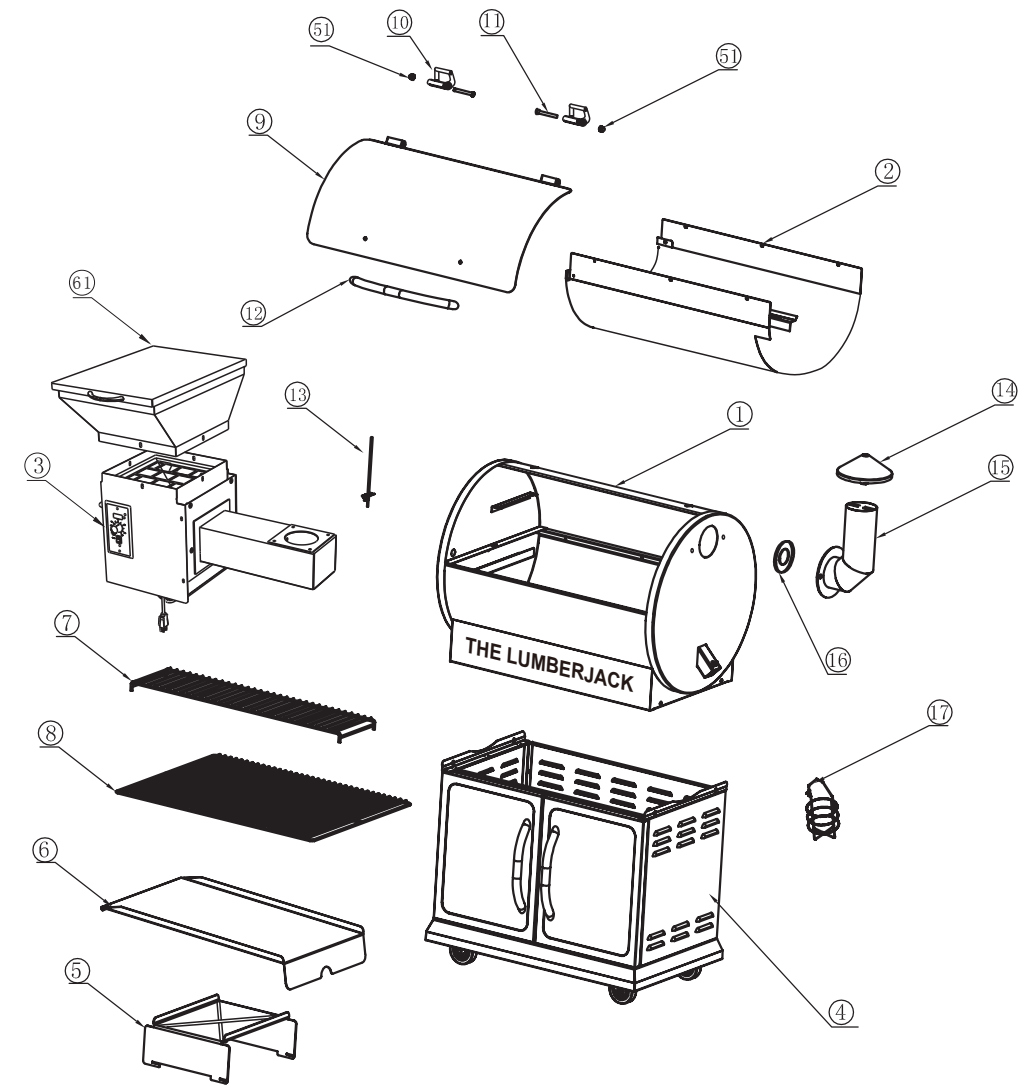

Hopper / Burner Assembly:

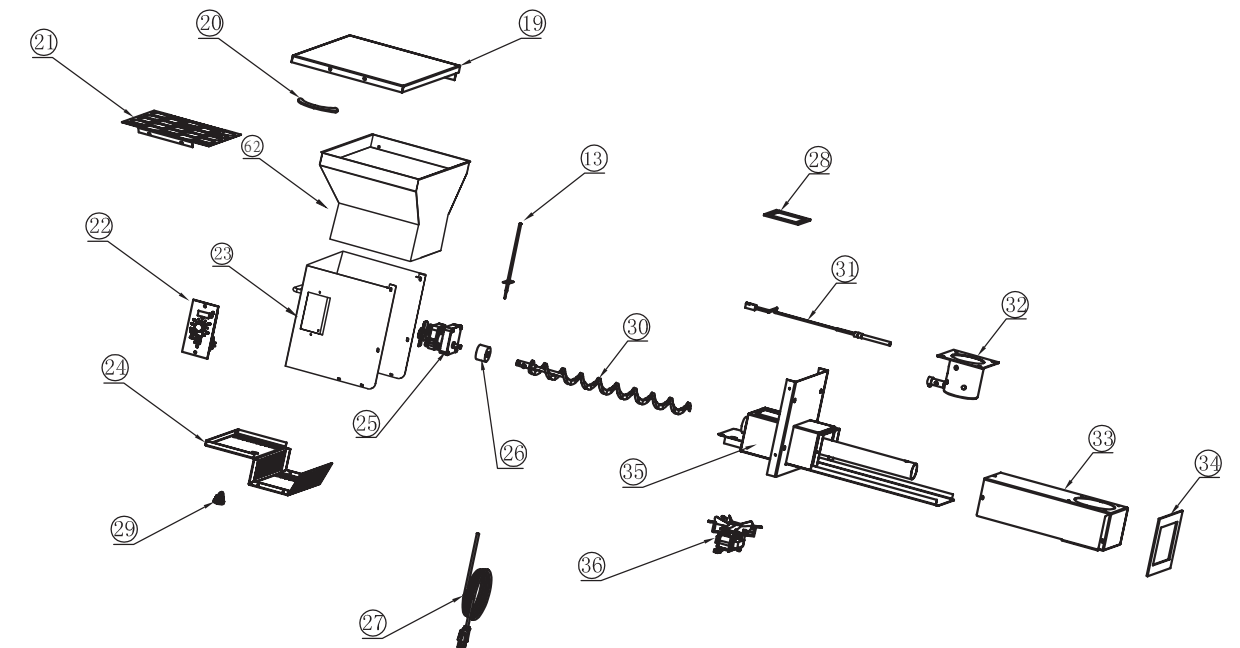

Body Frame Assembly:

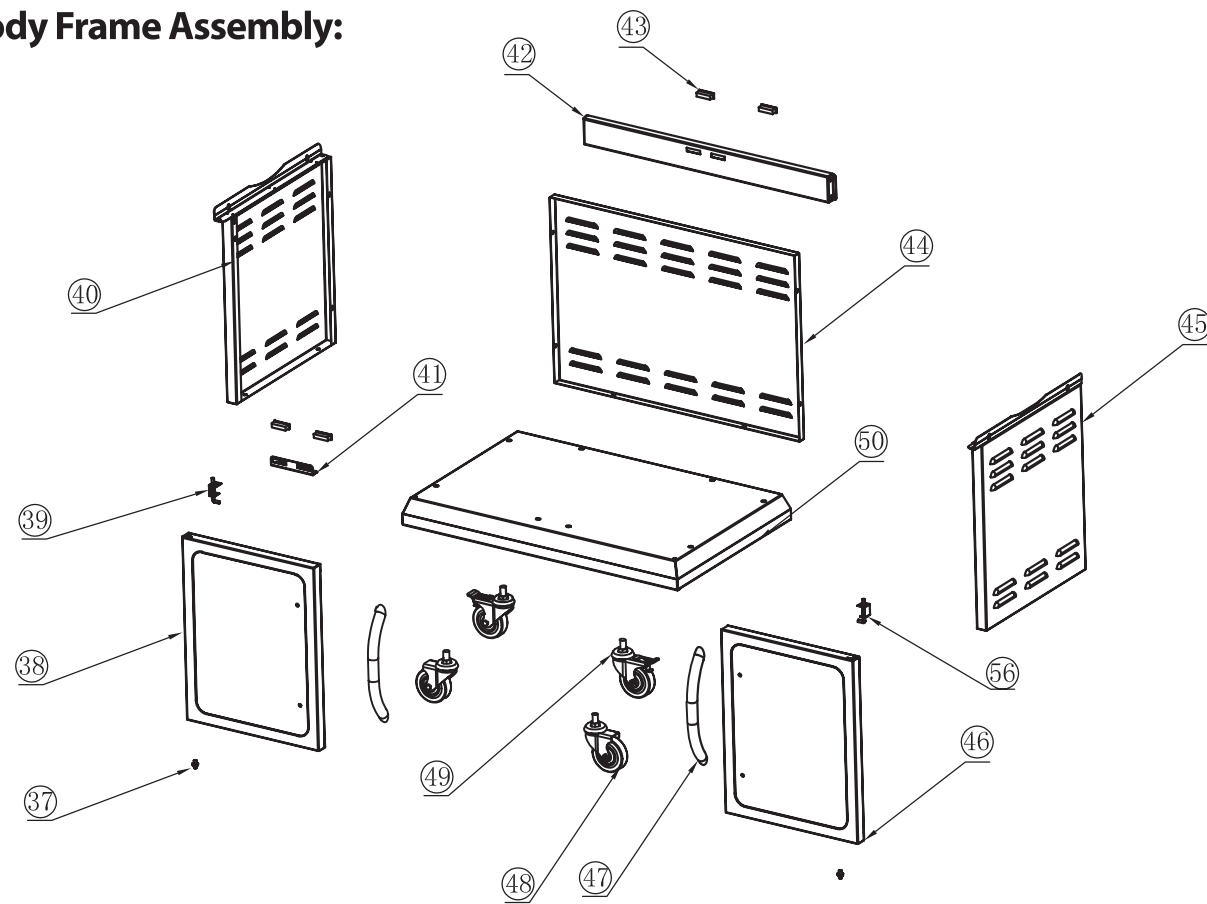

1. ASSEMBLING OF BOTTOM BASE:

1. Upside down the bottom base, install the wheel (without brake) into the screw hole, then tighten the wheel by wrench (59). Note: The 2 wheels without brake should be installed at the same side.

2. Install the wheel (with brake) into the screw hole, then tighten the wheel by wrench (59). Note: The 2 wheels with brake should be installed as the same side.

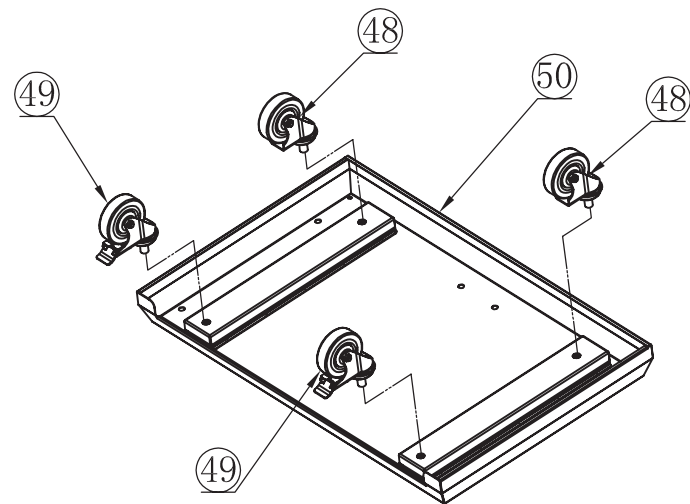

2. MOUNTING THE BODY FRAME:

1. Secure Left Plate (40) on the Platform (50) with 1/4-20*12mm Bolt (52).
2. Secure Right Plate (45) on the Platform (50) with 1/4-20*12mm Bolt (52).
3. Secure Back Plate (44) on the Platform (50) with 1/4-20*12mm Bolt (52) and link with Left Plate (40) and Right Plate (45).
4. Locate the Beam (42) between Left Plate (40) and Right Plate (45) with 1/4-20*12mm Bolt (52).

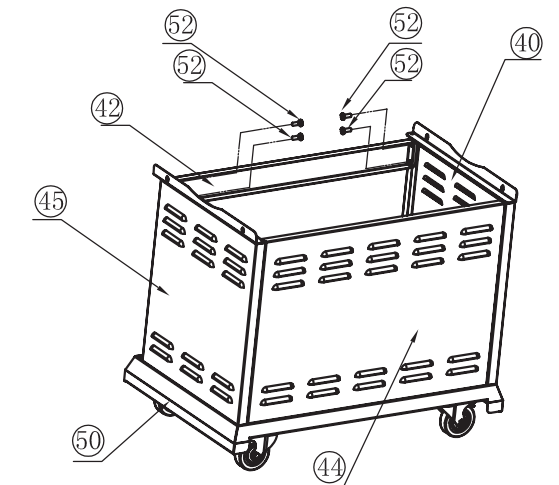
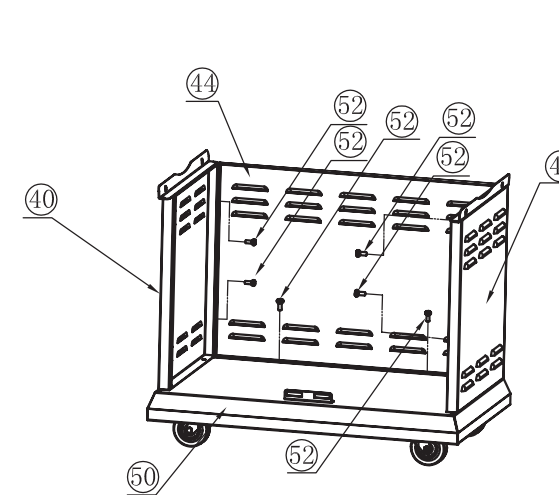
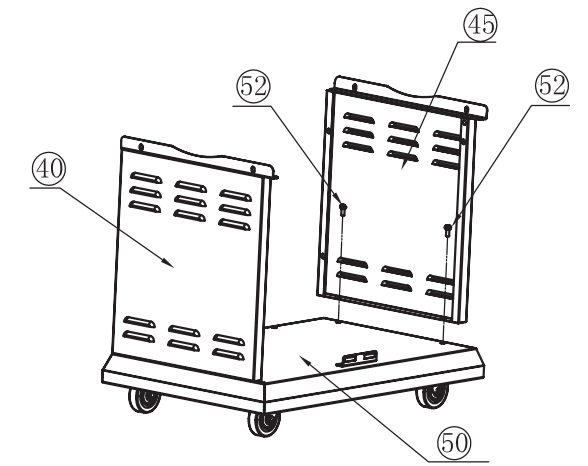
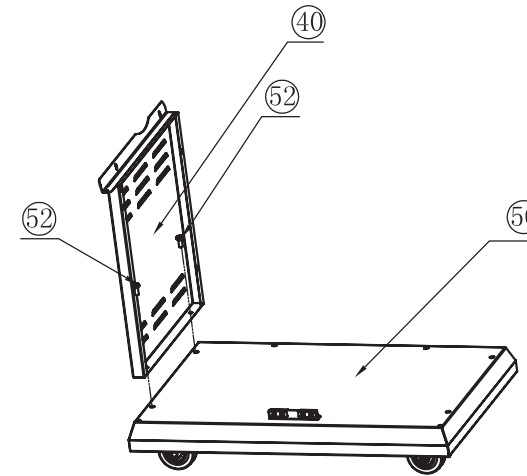

3.Assembling of Hopper

Insert Hopper Assembly I(61) into Hopper Bottom Cover(3), align the holes. Insert the 5/32-32*6mm Bolts(60) through the holes in the Hopper and 5/32-32 Kep Nuts(63), then open the Hopper Lid and tighten it from inside. The four sides are installed in the same way.

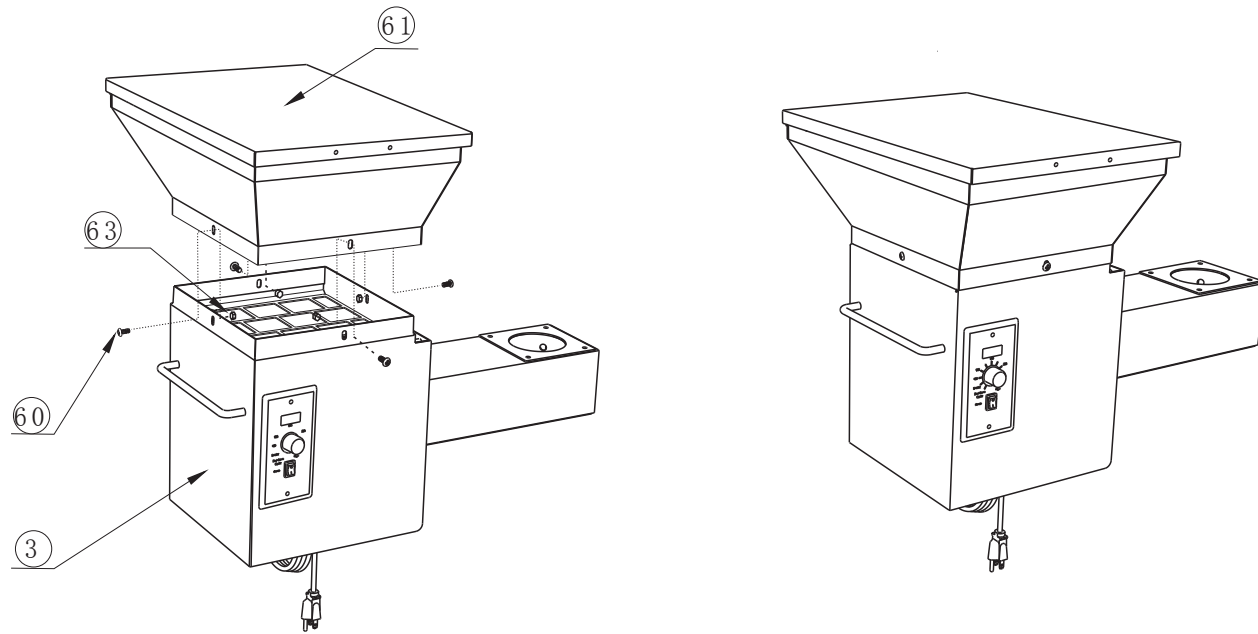

5.Mounting the Hopper to the Chamber

Remove the Gaskets and Bolts from the Hopper, open the Lid, insert the Hopper into the Chamber, then using these Bolts and Gaskets install it in sequence from inside.

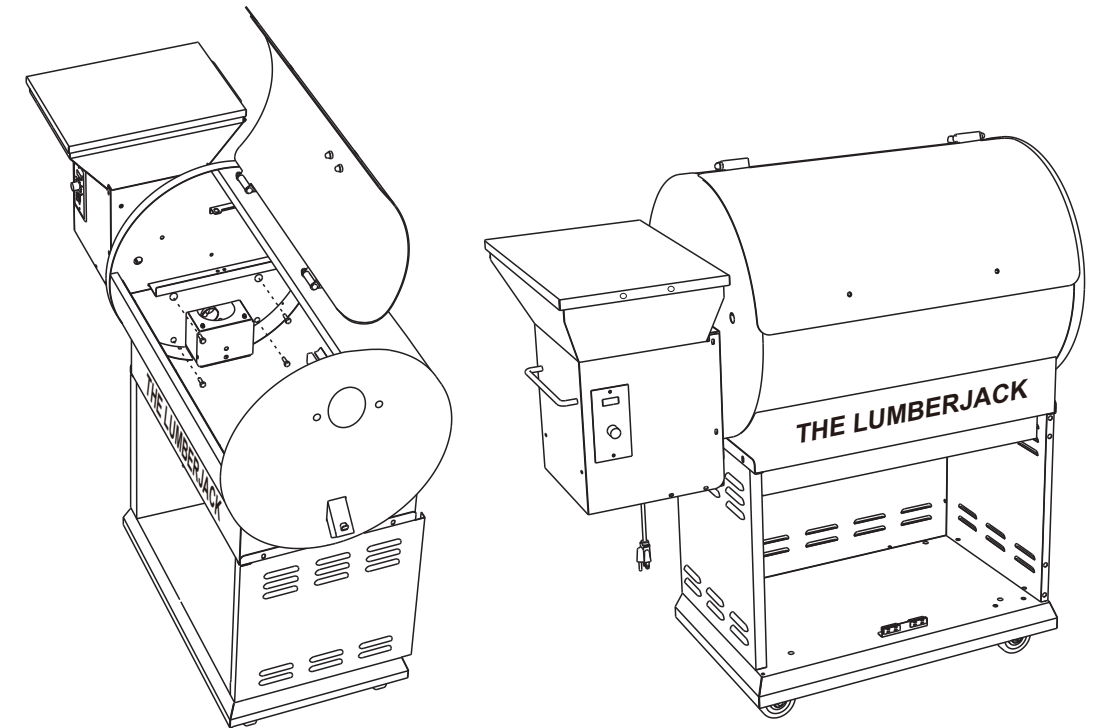

4.POSITIONING THE CHAMBER ON THE BODY FRAME:

Uplift the Chamber(1) on the Body Frame(4). Make sure that the Chamber(1) is between the left and right plate of the Frame(4). Align the Chamber holes with the plate holes and secure with 1/4-20*12mm Bolt(52).

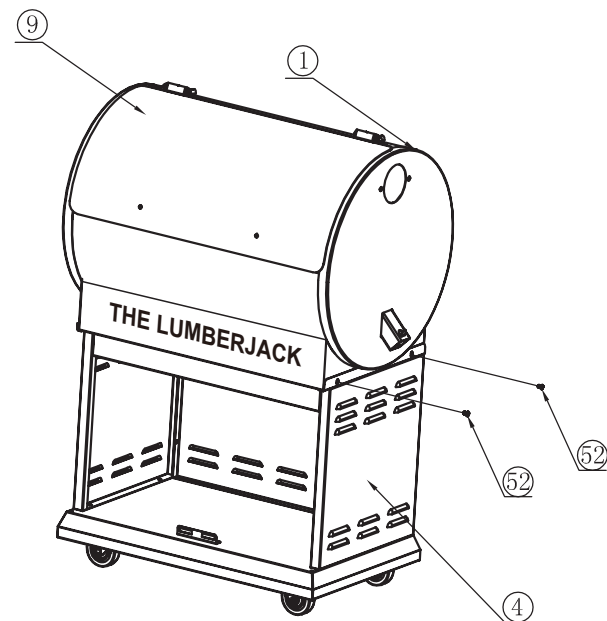

6.ATTACHING THE HOPPER BURNER LID DOOR HANDLE:

Keep the Hopper Burner Lid(19) open. Penetrate the 5/32-32*5MM Bolt(58) into Ø12*Ø4.2*1.0mm Gasket(57) and the hole on the Hopper Burner Lid(19) from inside. Tight the Bolt with screwdriver.

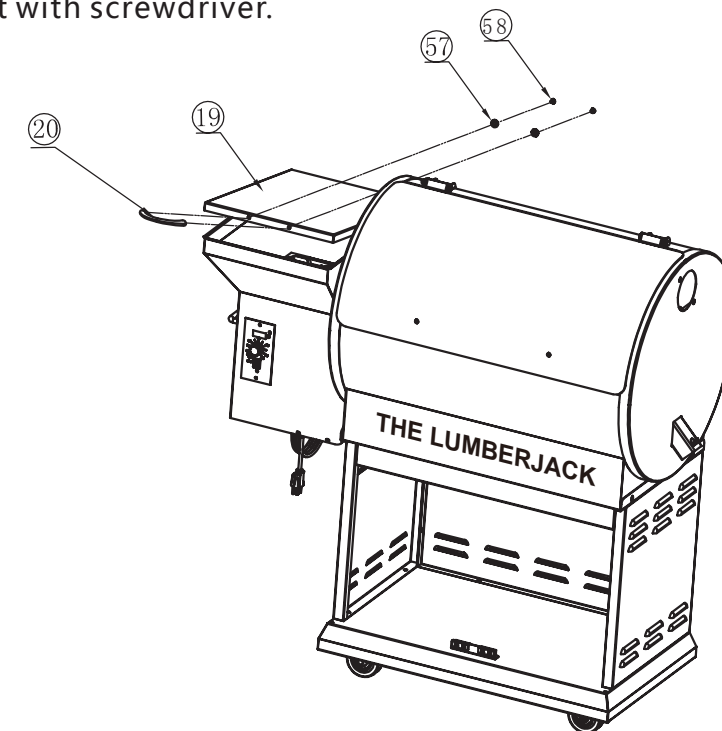

7. ATTACHING THE CHAMBER DOOR HANDLE:

Penetrate 1/4-20*12mm Hexagon Bolt(53) through Ø18*Ø6.5*2.0mm Gasket(54) and Lid(9) directly to the handle and tighten up. Do not screw over-tight.

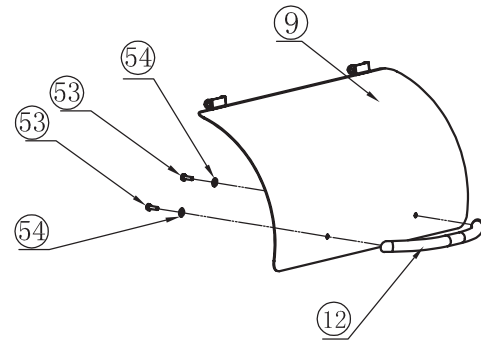

8. ATTACHING THE SMOKE STACK AND CHIMNEY CAP

1. Align the holes in the Smoke Stack(15) with holes in the Smoke Stack Gasket (16), which fits between right end of the Grill and the Smoke Stack Gasket(16). Insert the 1/4-20*12mm Hexagon Bolts(53) through the holes in the Smoke Stack(15) and the Smoke Stack Gasket(16).
2. Place a Ø18*Ø6.5*2.0mm Gasket(54) on each Bolt and secure with 1/4-20 Hexagon Nut(55).

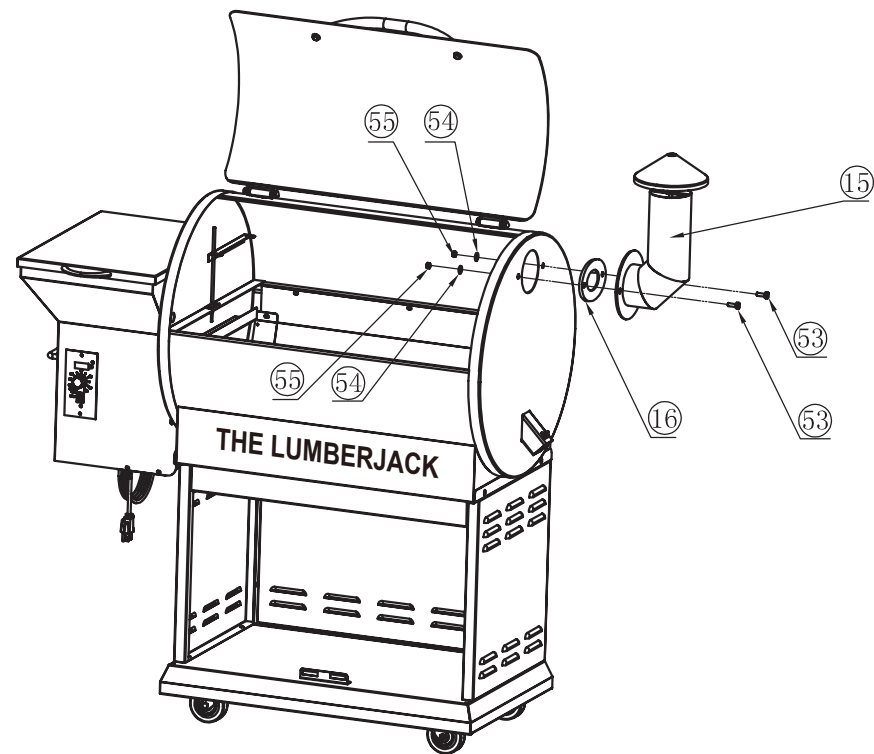

9. POSITIONING THE DOOR HANDLE

Align the holes in the Left Door(38) with the holes in the Handle(47). Place a Ø18*Ø6.5*2.0mm Gasket(54) on each 1/4-20*12mm Hexagon Bolt(53) and tight with Wrench. Repeat the former step to assemble the Right Door(46).

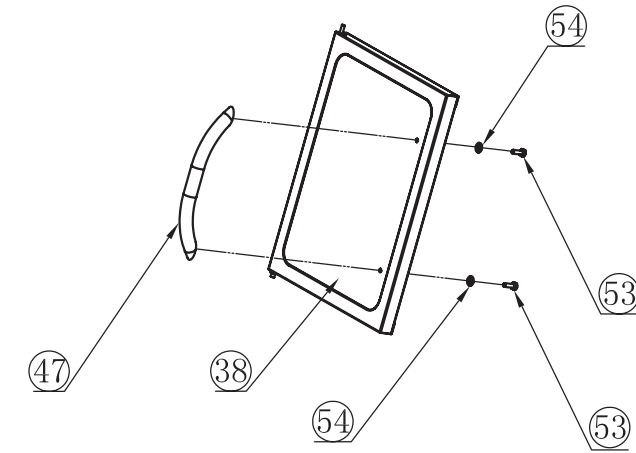

10. POSITIONING THE DOOR:

1. Take the Right Door(46) with handle assemble. First insert the Bottom Pivot(37) into the small hole on Platform(50). Then pull down the pivot until the upper end is aligned with top edge of the door. Then align the pivot with the upper hole and pull up the pivot to secure the door.
2. Repeat Step 1 to secure the Left Door(38). Make a proper adjustment until the doors can be firmly closed.

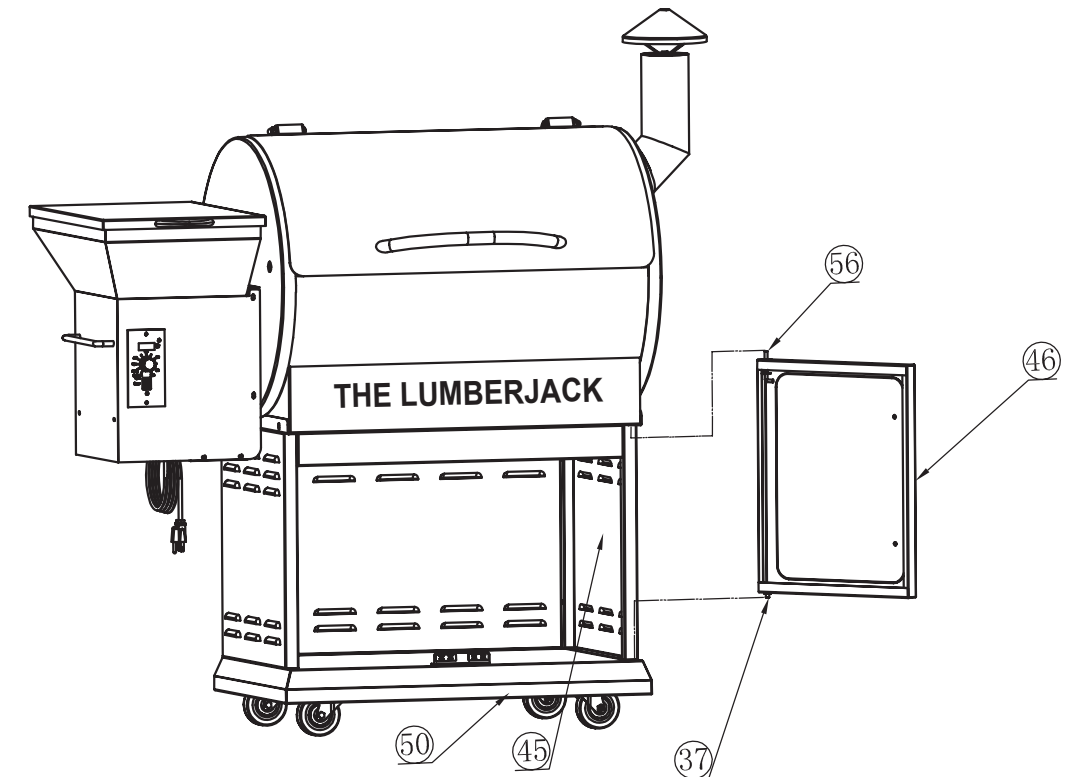

11. POSITIONING THE HEAT BAFFLE:

Position The Heat Baffle(5) on the locating brackets which is on the inside walls of the Grill. The notched legs should be facing downward.

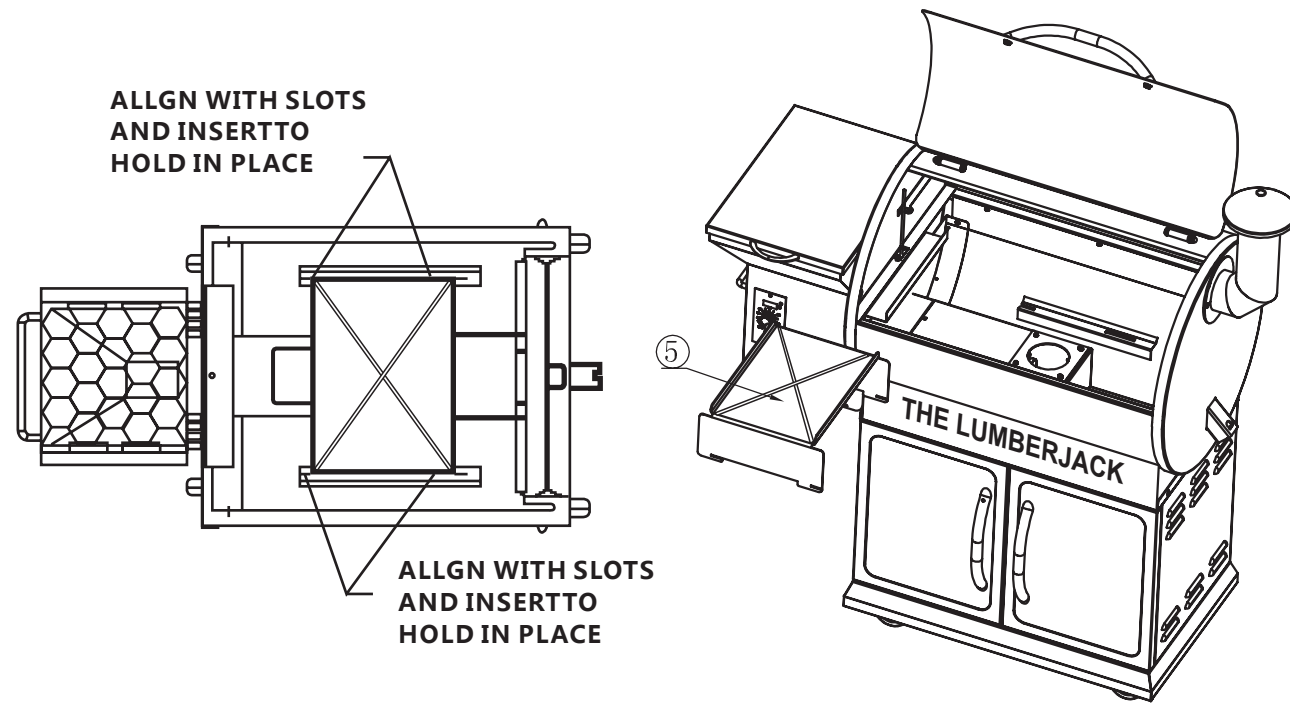

12. POSITIONING THE GREASE DRAIN PAN:

Position The Grease Drain Pan(6) over the Firepot. The notched legs of the Grease Drain Pan should be facing downward to fit onto the locating brackets so that the grease can flow into the Grease Drain Tube.

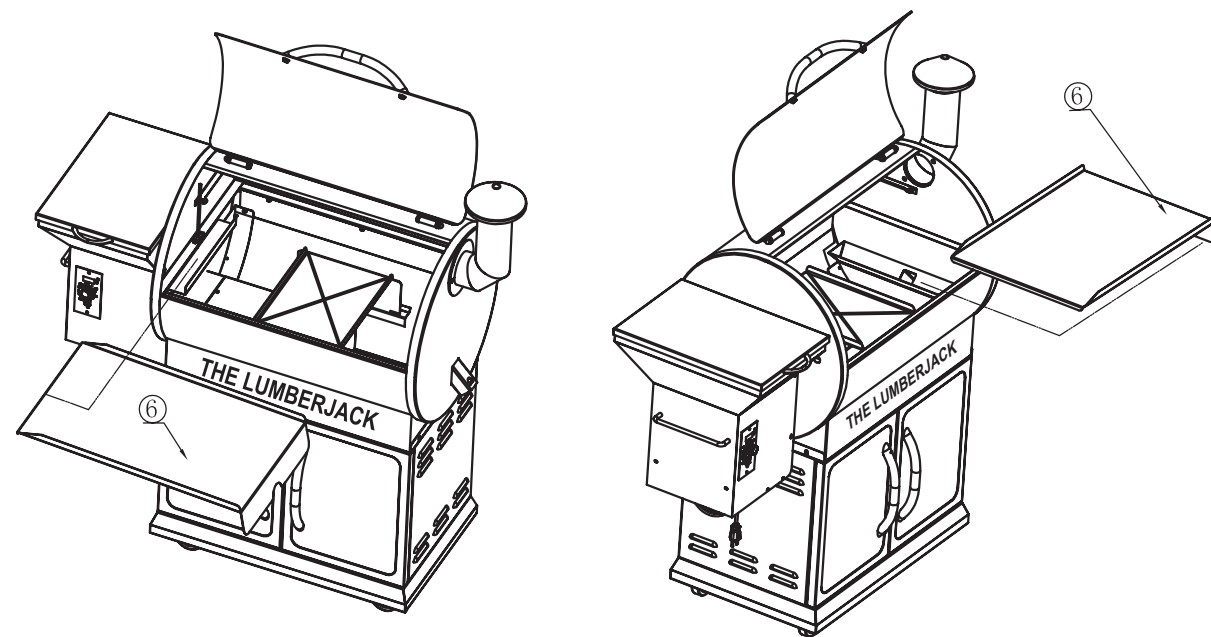

13. POSITIONING THE PORCELAIN GRILL:

Position the Porcelain Grill(8) inside the cooking area and locate the Warming Rack(7) on the rack support inside the Chamber.

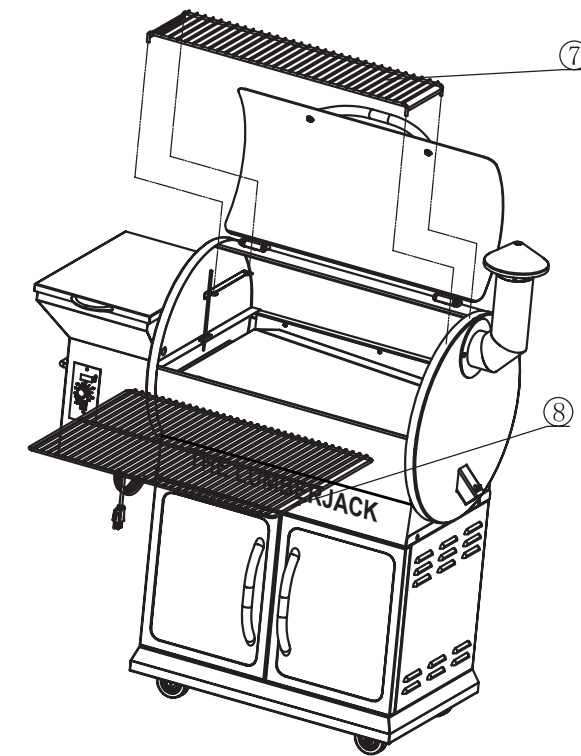

14. HANG ON THE GREASE BASKET:

Locate the Grease Drain Tube which is on the right side of the chamber, then hang the Grease Basket(17) on the hook.

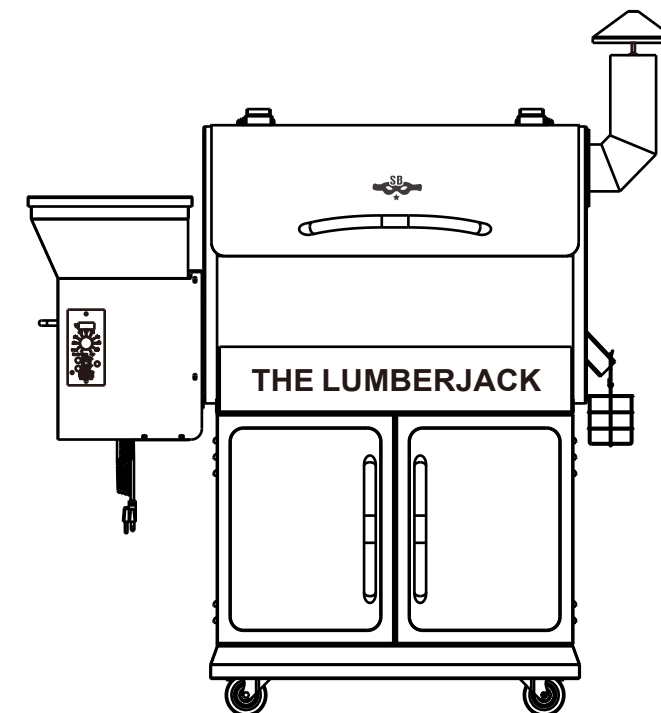

SECTION 2: INITIAL FIRING INSTRUCTIONS

(To be used on initial firing or anytime the Grill runs out of Pellets) In order to ensure proper operation of the Grill, you must first allow the Auger Tube to be “charged” with Pellets.

- 1) Open the Door and remove the Porcelain Grills, Grease Drain Pan and Heat Baffle from inside the Grill.
- 2) Make sure the Switch is in the OFF (O) position. Plug the Power Cord into an appropriate, grounded electrical outlet.
- 3) Open the Pellet Hopper Lid and locate the Auger. Make sure there are no foreign objects in the Auger. Turn the Switch ON and the Temperature/dial to smoke look into the Pellet Hopper to confirm the Auger is turning. At the same time, place your fingers over the Firepot and feel the air movement from the Draft Inducer Fan. Look to see if the Hot Rod is getting hot (it will start to turn red). **CAUTION! Do not touch it.** Turn the Temperature/dial to SHUT DOWN CYCLE. Note the draft fan will stay on for 10 minutes in this mode.
- 4) The Pellet Hopper with pellets. **WARNING!** Use only Smokey Bandit BRAND BBQ PELLETS, which are specifically made to work in our Grills. Never use heating fuel pellets in the Grill. Turn the Temperature/Dial to HIGH. Note: During the initial charging of the Auger, it will take time for the Pellets to travel from the Pellet Hopper to the Firepot. When the Pellets begin to fall into the Firepot, turn the Temperature/Dial to Shut Down Cycle.
- 5) Set the Temperature/Dial to SMOKE. Let the Pellets come to full flame. Once you see flames come out of the Firepot, turn the Temperature/Dial to SHUT DOWN CYCLE, and let the Grill cool down.
Recommendation: For ease of clean-up, line the Grease Drain Pan with heavy duty aluminum foil. Be sure the edges and ends of the foil are tight against the bottom of the Grease Drain Pan. Position the Heat Baffle, The foil lined Grease Drain Pan and Porcelain Grills in their proper locations.
- 6) With the Door open set the Temperature/Dial to SMOKE. In approximately 2 minutes you will notice whitish-gray smoke coming out of the Grill as the Pellets ignite. After assuring the Pellets have ignited, close the Door and set the Temperature/Dial to any cooking setting desired.
- 7) **Note: Before cooking the first batch of food in your new Grill, you will need to season the Grill. Turn the Temperature/Dial to HIGH and run for 45 minutes at this setting with the Door closed. This must be done before cooking any food on the Grill.**
- 8) The Grill should be allowed to preheat for approximately 10 minutes with the Door closed before placing food in the grill.

WARNING!

- ALWAYS Start the grill on smoke setting with the door open! Once the Pellets are ignited, close the Door and set the Temperature Dial to any cooking temperature desired.
- When operating this Grill, maintain a minimum clearance of 12 inches from Grill to combustibles.

SECTION 3: SUBSEQUENT START-UP

WARNING!

If at any time, the Grill fails to light or the fire in the Firepot goes out while cooking or smoking, when sufficient pellets are still in the Pellet Hopper, it is important to follow these steps. Failure to do so may cause a hazardous “over-firing” of your grill due to an excess of unburned pellets in the Firepot.

1. **DANGER!** Turn the Switch OFF (O) and disconnect the Power Cord. If the Grill is still hot, allow it to thoroughly cool. Open the Door and remove all food, the Porcelain Grills, Grease Drain Pan and the Heat Baffle.
2. **WARNING!** Remove all unburned pellets and ash from inside and around the Firepot. (See instructions for proper handling and disposal of ash in Section 5)
3. Before replacing the Heat Baffle, Grease Drain Pan and the Porcelain Grills, plug the power Cord into an appropriate, grounded electrical outlet and restart the Grill. Pellets should fall into the Firepot and the Hot Rod should begin to heat (it will start to turn red). **CAUTION!** Do not touch it.
4. If this procedure is successful, you will soon see flames come out of the Firepot. Then turn the Switch OFF (O), and let the Grill cool down. Position the Heat Baffle, the Grease Drain Pan and Porcelain Grill in their proper locations. With the Door open, turn the Switch ON (I) and the Temperature/Dial to SMOKE. In approximately 2 minutes you will notice whitish-gray smoke coming out of the Grill as the Pellets ignite. After assuring the Pellets have ignited, close the Door and set the temperature/Dial to any cooking setting desired.
5. If this procedure is not successful, see SECTION6: FREQUENTLY ASKED QUESTIONS for troubleshooting tips or contact Smokey Bandit Technical Support (SECTION7) to help diagnose the problem before proceeding to the MANUAL LIGHTING INSTRUCTIONS below:

1.Manual Lighting Instructions:

If the Hot Rod only is not operating, the Grill can still be used to cook and smoke using the MANUAL LIGHTING PROCEDURE below:

1. **DANGER!** Turn the Switch OFF (O) and disconnect the Power Cord. Allow the Grill to thoroughly cool if it is still hot. From beneath the Pellet Hopper, disconnect the Hot Rod (Purple / White wire pair as shown in the wiring diagram near the end of this manual). You will need to remove the Hopper Bottom Panel to access the wiring. Once the Hot Rod is disconnected, replace the Hopper Bottom Panel and plug the Power Cord back into an appropriate, grounded electrical outlet.

2. Open the Pellet Hopper and fill with pellets.

WARNING! USE ONLY Dia 6MM PELLETS ONLY, which are specifically made to work in our Grills. NEVER use heating fuel pellets in the Grill due to potential hazardous contaminants and additives that may be present.

3. Remove the Porcelain Grills, Grease Drain Pan and Heat Baffle to expose the Firepot in the bottom of the Grill.

4. Pour 1/2 cup of pellets into the Firepot.

5. Squirt 2 tablespoons of Alcohol Gel fire lighter into the Firepot on top of the Pellets.

DANGER! Never use gasoline, gasoline-type lantern fuel, kerosene, charcoal lighter fluid or similar liquids to start or “freshen up” a fire in this Grill. Keep all such liquids well away from the Grill when in use.

6. Carefully light the Alcohol Gel with a fireplace match or a long-reach butane lighter. **DANGER!** Never squirt Alcohol Gel into a burning fire or a hot Firepot. The Alcohol Gel bottle could explode and cause a fire, serious injury or death.

7. Let the Alcohol Gel and Pellets burn for approximately 4 minutes.

8. After assuring the Pellets have ignited, install the Heat Baffle, Grease Drain Pan and Porcelain Grills back in place. **CAUTION!** You will now have a fire in the Firepot. Be careful not to burn yourself when you install these components. Gloves are recommended.

9. Turn the Switch ON (I) and the Temperature/Dial to any setting desired. With the Door closed, let the Grill pre-heat for approximately 10 minutes before placing food in the Grill.

2. Control Shutdown Cycle

The control for this barbecue comes with an automatic shut down cycle. When finished cooking on your barbecue set the Temperature/Dial Knob to the Shutdown Cycle position, this will leave the Draft Induction Fan running for 10 minutes to burn any excess pellets in the fire pot. After the fan runs for 10 minutes the controller will power off and the fan will stop running.

CAUTION! The main power switch will shut the power off to the controller and the Temperature/Dial Knob switch will cut off power to the grill components only. When servicing the controller or any parts ensure that the power supply is disconnected to avoid a shock hazard.

3. Control Safety Features

The controller comes equipped with 2 safety features that will help you to keep the grill operating correctly. The first of these is a low temperature alarm. If the grill stays below 125 degrees as read by the RTD temperature sensing device for a period of 10 minutes the control will go into an alarm state and the display will read “LEr”. This will shut off all power to the internal components of the grill. The display will stay in this state until you turn off the main power switch. The second safety feature will be a high

temperature alarm. If the grill obtains an internal temperature reading of 550 degrees as read by the RTD temperature sensing device the control will go into alarm state and the display will read “HEr”. This will turn off all power to the internal components of the grill. The display will stay in this state until you turn off the main power switch. Whenever either of these alarm conditions occurs you should check to see what caused this condition and fix the problem. Call customer service if you need help.

SECTION 4: OPERATING TIPS

1. The Temperature Dial can be changed at any time to increase or decrease the cooking temperature of the Grill. The HIGH/HIGHER temperature settings are for Grilling. The MEDIUM/MID RANGE temperature settings are for Slow Cooking. The SMOKE setting is for Smoking and adding Smoke Flavor to foods being cooked. The SMOKE setting can also be used to “hold” foods at approximately 180 to 200 degrees F.

2. **WARNING!** Your Smokey Bandit Pellet Grill should never be moved while it is hot. If you are transporting your Grill in a vehicle after cooking on it, make sure the fire is completely out and the Grill is cold before placing it in any vehicle. Never put water into the Firepot. It will jam the Auger.

3. Your Smokey Bandit Pellet Grill is designed to operate with the Door closed. Cooking with the Door open greatly lengthens your cooking time.

4. **DANGER!** Never add pellets by hand to a hot Firepot. This is dangerous and you may be seriously burned. If you run out of pellets and lose your fire while cooking, let the Grill completely cool and start again with the INITIAL FIRING INSTRUCTIONS.

5. **CAUTION!** Make sure the Heat Baffle is properly seated on its locating brackets. The long lips of the Heat Baffle should be pointing down over the Firepot. If not seated properly, direct heat and flame could come up out of the Firepot and cause a grease fire in the Grill.

6. When estimating cooking times, the outside temperature will be an important factor. If it is hot outside, it will take less time for food to cook. If it is cold, wet or windy, it will take longer.

7. Digital Thermostat Control Functions:

After selecting your cooking temperature (with the exception of “SMOKE”) the Auger will operate continuously until the selected temperature is reached. From that point forward, the Digital Control will cycle the Auger off and on to maintain the selected temperature until the Temperature/Dial is changed. When operating in “Smoke” mode, the Auger will cycle on for 15 seconds and off for 65 seconds. There is no temperature control with the “Smoke” setting. This timed cycle setting for “Smoke” is a factory pre-set recommended by Smokey Bandit Pellet Grills to develop a “Smoking” temperature of 150 to 180 degrees F. However you can change this timed cycle to suit your particular needs. Refer to the Wiring Diagram found near the end of this manual and locate the Smoke Adjustment. It is a switch inside a small hole on the face of the Digital Control to the right of the Readout. While the Digital Control is on, use a very small

screwdriver or other pointed object (a bent paper clip works well) to gently depress the switch. When you depress the switch, the Readout will change from a temperature to "P" followed by a number. The factory pre-set mentioned earlier is P-2. The setting range is from P-0 to P-5. The "P" readout will change each time you depress the switch. With all "P" settings, the Auger on time remains constant at 15 seconds while the off time is influenced by the "P" setting. For example: A P-3 setting will result in an Auger on time of 15 seconds and an Auger off time of 75 seconds, an increase in the off time of 10 seconds from the P-2 setting. Each change in the "P" number -up or down results in an increase or decrease of 10 seconds for the Auger off time. Increasing the number decreases Smoking Temperature. Decreasing the number increases Smoking Temperature. Service Department recommends a setting no higher than P-4. Also, if you do make a Smoke Adjustment, the temperature on the Readout should be monitored. If the temperature is consistently below 160 degrees F. while "Smoking", decrease the "P" setting because there is a risk of losing the fire in the Firepot.

8. Carbon monoxide:

WARNING! Follow these guidelines to prevent this colorless, odorless gas from poisoning you, your family or others.

- a) Know the symptoms of carbon monoxide poisoning: headache, dizziness, weakness, nausea, vomiting, sleepiness and confusion. Carbon monoxide reduces the blood's ability to carry oxygen. Low blood oxygen levels can result in loss of consciousness and death.
- b) See a doctor if you or others develop cold or flu-like symptoms while cooking or in the vicinity of this Grill. Carbon monoxide poisoning, which can easily be mistaken for a cold or flu, is often detected too late.
- c) Alcohol consumption and drug use increase the effects of carbon monoxide poisoning.
- d) Carbon monoxide is especially toxic to mother and child during pregnancy, infants, the elderly, smokers and people with blood or circulatory problems, such as anemia or heart disease.

9. **CAUTION!** Grease fires are caused by not properly maintaining the Grill by failing to clean your Grease Drain Pan, V-shaped Grease Drain and Grease Drain Tube on a consistent basis. (See Section 5 for maintenance instructions) In the unlikely event of a grease fire while cooking, turn the Switch OFF (O) and Keep the Door closed until the fire is completely out. Never keep the Door open during a grease fire. If it does not go out, lightly sprinkle baking soda on the fire. CAUTION! Be careful not to burn yourself. If this does not work then carefully remove the food from the Grill and keep the Door closed until the fire is completely out. Again, be careful not to burn yourself. When the Grill is completely cool, remove the Porcelain Grills and replace the foil on the Grease Drain Pan. Clean any grease accumulation from the Vshaped Grease Drain and the Grease Drain Tube. Replace the Grease Drain Pan and the Porcelain Grills in their proper positions, restart the Grill and resume cooking.

WARNING!

If the fire in the Firepot goes out while smoking, when sufficient Pellets are still in the Pellet Hopper, it is important to follow these steps. Failure to do so may cause a hazardous "over-firing" of your grill due to an excess of unburned pellets in the Firepot. You may need to decrease the "P" setting to prevent your fire from going out in the "Smoke" mode.

- a) **DANGER!** Turn the Switch OFF (O) and disconnect the Power Cord. Allow the Grill to thoroughly cool if it is still hot. Open the Door and remove all food, the Porcelain Grills, Grease Drain Pan and the Heat Baffle.
- b) **WARNING!** Remove all unburned pellets and ash from inside and around the Firepot. (See instructions for proper handling and disposal of ash in Section 5)
- c) Before replacing the Heat Baffle, Grease Drain Pan and the Porcelain Grills, plug the Power Cord into an appropriate, grounded electrical outlet and turn the Switch ON (I). Pellets should fall into the Firepot and the Hot Rod should begin to heat (it will start to turn red). CAUTION! Do not touch it.
- d) You will soon see flames come out of the Firepot. Then turn the Switch OFF (O), and let the Grill cool down. Position the Heat Baffle, the Grease Drain Pan and Porcelain Grills in their proper locations. With the Door open, turn the Switch ON (I) and the Temperature/Dial to SMOKE. In approximately 2 minutes you will notice whitish-gray smoke coming out of the Grill as the Pellets ignite. After assuring the Pellets have ignited, close the Door and set the Temperature/Dial to any cooking setting desired.

SECTION 5: MAINTAINING YOUR NEW GRILL

1. CREOSOTE AND GREASE:

When wood pellets are burned slowly, they produce tar and other organic vapors that combine with expelled moisture to form creosote. The creosote vapors condense in the relatively cool flue exhaust of a slow burning fire. As a result, creosote accumulates on the flue lining. When ignited, creosote makes an extremely hot fire. Airborne grease particles will travel through the cooking chamber and some of this airborne grease will accumulate on the flue lining, similar to the creosote, which could be contributory to a fire.

The flue exhaust should be inspected at least twice a year to determine when a creosote and/or grease buildup has occurred. Also, grease drippings from the food will fall onto the Grease Drain Pan and be channeled into the Grease Drain and then out of the Grill through the Grease Drain Tube, to be collected in the Grease Basket. Grease will accumulate in all of these locations.

The Grease Drain and the Grease Drain Tube should be inspected at least twice a year for signs of grease buildup. When creosote or grease has accumulated, it should be removed to reduce the risk of fire.

a) Cleaning the Flue (Smoke Stack):

DANGER! Turn the Switch OFF (O) and disconnect the Power Cord.

CAUTION! Make sure that the Grill is cold before cleaning the Flue Pipe. Remove (unscrew) the Chimney Cap Assembly from the top of the Flue Pipe. Once the Chimney Cap Assembly has been removed, it can be cleaned with warm, soapy water or with a biodegradable degreaser.

Scrape the creosote and grease accumulation from the inside of the vertical and horizontal sections of the Flue Pipe, using a stiff, non-metallic tool. A wooden paint stir stick, for example, would work for this task. Once the creosote and grease residue has been loosened from the Flue Pipe lining, much of it can be removed with paper towels or disposable rags. Do not spray water or other liquid cleaners onto the inside of your Grill. Once the Flue Pipe has been cleaned, replace the Chimney Cap Assembly.

b) Cleaning Grease from your Grill:

DANGER! Turn the Switch OFF (O) and disconnect the Power Cord.

CAUTION! Accumulated grease is easier to clean off when the Grill is still warm –not hot. Be careful not to burn yourself. Gloves are recommended. Periodically, clean the grease out of the V-shaped Grease Drain and Grease Drain Tube. If too much grease is allowed to build up in the V-shaped Grease Drain, or is allowed to plug the Grease Drain Tube, a grease fire could result. We recommend cleaning these locations regularly.

Remove the Porcelain Grills and the Grease Drain Pan. This will provide access to the V-shaped Grease Drain and Grease Drain Tube opening inside the Grill. Scrape the grease accumulation from the inside the V-shaped Grease Drain and Grease Drain Tube, using a stiff, non-metallic tool. Much of the loosened

grease can be pushed down through the Grease Drain Tube and will fall into the Grease Basket. Wipe up remaining grease residue with paper towels or disposable rags. Paper towels or disposable rags can also be used to wipe some of the grease off of the interior surfaces of the Grill.

Line your Grease Bucket with aluminum foil for easy clean-up. Empty it occasionally, depending on amount of use. Change the aluminum foil on the Grease Drain Pan frequently (sometimes, after each use, depending upon what was cooked). Clean foil on the Grease Drain Pan will make your food taste better and reduce the risk of a grease fire.

2. Cleaning outside surfaces:

DANGER! Turn the Switch OFF (O) and disconnect the Power Cord. Use a disposable rag or cloth, dampened with warm soapy water to wipe the grease from the outside of the Grill. DO NOT use oven cleaner, abrasive cleansers or abrasive cleaning pads on the outside Grill surfaces.

3. Outside Storage:

CAUTION! If the Grill is stored outside during the rainy season, care should be taken to ensure that water does not get into the Pellet Hopper. Wood pellets, when wet, expand greatly and will jam your Auger. A Smokey Bandit Grill Cover to protect the Grill is highly recommended! Covers are available from your Smokey Bandit Dealer, or log on to our Web Site.

4. Cleaning the Porcelain Grills:

CAUTION! The cleaning of the Porcelain Grills works best while they are still warm. Be careful not to burn yourself. We recommend keeping a long-handled cleaning brush near the Grill. After removing your food, give the Porcelain Grill a quick brushing. It takes only a minute and it will be ready the next time you want to use the Grill.

5. Cleaning the ash from inside and around the Firepot:

DANGER! Turn the Switch OFF (O) and disconnect the Power Cord.

WARNING! Make sure that the Grill is COLD before cleaning the ash.

WARNING! Disposal of ashes should be done only per the following instructions.

Excess ash in the Firepot may cause your fire to go out, especially in the "SMOKE" setting. The Firepot should be inspected occasionally, and cleaned to remove the ash buildup. Again, cleaning the ash from in and around the Firepot should be done only when the Grill is COLD. Remove the Porcelain Grills, Grease Drain Pan and Heat Baffle to provide access to the Firepot and the interior of the Grill. Much of the ash outside of the Firepot can be swept to the open area at the right of the Firepot using a small whisk broom. It can be removed from the Grill with a small metal fireplace shovel or other similar tool. Dispose of the ashes per the following instructions.

WARNING! A vacuum cleaner is the best way to remove ashes from the Firepot but this must be done with extreme care to avoid the risk of fire. Again, cleaning the ash from the Firepot should be done only

when the Grill is COLD. A utility-type vacuum cleaner, having a metal collection canister without a bag would be best for this task. However, almost any vacuum cleaner will work safely if this procedure is properly followed. After assuring that the ash in the Firepot is COLD, vacuum the ash from the inside of the Firepot.

a) If your vacuum cleaner is a bagless model, empty any previously accumulated debris from the collection chamber. Then vacuum the ash from the inside of the Firepot. Once the Firepot is clean, empty the collection chamber into the metal container described below without delay. Make sure that there is no remaining ash residue left in the collection chamber

b) If your vacuum cleaner is a model that uses a disposable bag, install an unused one in the machine. Then vacuum the ash from the inside of the Firepot. Once the Firepot is clean, remove the bag from the vacuum cleaner and place it in the metal container described below without delay.

6. Disposal of Ashes:

WARNING! Ashes should be placed in a metal container with a tight-fitting lid. The closed container of ashes should be placed on a non-combustible floor or on the ground, well away from all combustible materials, pending final disposal. When the ashes are disposed of by burial in soil or otherwise locally dispersed, they should be retained in the closed container until all cinders have thoroughly cooled.

SECTION 6: FREQUENTLY ASKED QUESTIONS

1. WHY WON'T MY GRILL IGNITE?

1. Verify power at the electrical outlet.

a) If Power Cord is connected to a GFI (Ground Fault Interrupter), check and reset if necessary.

b) Initiate startup. Still no ignition – Proceed to step 2.

2. **DANGER!** Turn the Switch OFF (O) and disconnect the Power Cord.

a) Remove the Control and check the fuse on back. Replace the fuse if blown. Reinstall the Control!

b) Unplug Hot Rod connector (Purple/White wire pair), plug Power Cord into an appropriate, grounded electrical outlet and turn the Switch ON (I). NOTE: At this point the Grill will not ignite.

c) Check the Draft Inducer Fan and the Auger Drive Motor for operation. If both are operating -- the Hot Rod needs to be replaced. If one or both are not operating, contact Smokey Bandit Technical Support (Section 7) for additional troubleshooting help. Contact your Smokey Bandit Dealer or the Smokey Bandit Parts Department (Section 7) to place an order.

3. If the problem is identified to be a failed Hot Rod, the Grill can still be used to cook and smoke by following the MANUAL LIGHTING INSTRUCTIONS IN Section 3 of this OWNER'S MANUAL.

2. WHY ARE NO PELLETS BEING DELIVERED INTO THE FIREPOT?

1. Verify that there are Pellets in the Pellet Hopper. If this is the INITIAL FIRING or the Grill has run out of Pellets, allow sufficient time for the Pellets to travel from the Pellet Hopper to the Firepot (can take up to 7 minutes).

2. Initiate startup. See INITIAL FIRING INSTRUCTIONS in Section 2 of this OWNER'S MANUAL. Still no Pellets in the Firepot – Proceed to step 3.

3. **DANGER!** Turn the Switch OFF (O) and disconnect the Power Cord.

a) Unplug the Auger Drive Motor (Red/White wire pair connector) and the Draft Inducer Fan (Orange/White wire pair connector).

b) Reconnect the Draft Inducer Fan to the Red/White wire pair and the Auger Drive Motor to the Orange/White pair.

c) Plug the Power Cord into an appropriate, grounded electrical outlet and turn the Switch ON (I).

d) If the Auger Drive Motor is operating (check the small fan blade on the back of the motor), the problem is in the Three Speed or Digital Control, which will need to be replaced. Contact your Smokey Bandit Dealer or the Smokey Bandit Parts Department (Section Seven) to place an order.

4. If the Auger Drive Motor is not operating but the Draft Inducer Fan is operating, the problem is in the Auger system, which will need to be checked.

a) With the Switch OFF (O), locate the small fan blade on the back of the Auger Drive Motor.

b) CAUTION! While watching the fan blade, turn the Switch ON (I). If the fan blade does not turn, turn the Switch OFF (O). This indicates a defective Auger Drive Motor and it will need to be replaced. Contact your Smokey Bandit Dealer or the Smokey Bandit Parts Department (Section 7) to place an order.

c) If the fan blade turns a bit and then stops, continue watching and turn the Switch OFF (O). If the fan blade UNWINDS slightly, this indicates a jam in the Auger system which will need to be cleared.

d) **DANGER!** Turn the Switch OFF (O) and disconnect the Power Cord. Remove the Pellets from the Pellet Hopper. Check for foreign objects and wet or decomposed Pellets, both of which can cause a jam in the Auger system. The Auger will need to be removed to clear a jam in the Auger system. See “HOW DO I REMOVE THE AUGER IF IT JAMS?” section below.

3.HOW TO REMOVE THE AUGER IF IT JAMS?

1. **DANGER!** Turn the Switch OFF (O) and disconnect the Power Cord.
2. **CAUTION!** If the Grill is still hot, allow it to thoroughly cool.
3. Remove any covers necessary to access the Auger Drive Motor.
4. Remove the screw connecting the Auger Drive Motor shaft to the Auger shaft and the screw retaining the Auger Bushing into the Auger Tube.
5. With a small pipe wrench or locking pliers on the Auger shaft, turn the Auger counter clockwise. It will turn hard until it breaks free, then the Auger will turn freely.
6. Remove the Auger and clean all Pellets, ash or foreign objects from the Auger, Auger Tube and Firepot. (See instructions for proper handling and disposal of ash in Section 5)
7. Sand the outside surfaces of the auger with medium grit sandpaper. Check the inside of the Auger Tube and sand it if needed. Vacuum the sanding grit out of the Auger Tube and Firepot when finished. Check that the Auger rotates freely.
8. Re-attach the Auger shaft to the Auger Drive Motor shaft.

4.WHY DOES MY GRILL FIRE GO OUT ON “SMOKE” SETTING?

1)The “P” number for the Smoke Adjustment on the Digital Control may be set too high.

Review the Digital Thermostat Control Functions in Section 4: Operating Tips to make an adjustment.

2)There may be excess ash in the Firepot which needs to be cleaned.

WARNING! If the fire in the Firepot goes out while smoking, when sufficient Pellets are still in the Pellet Hopper, it is important to follow these steps. Failure to do so may cause a hazardous “over-firing” of your grill due to an excess of unburned pellets in the Firepot.

a) **DANGER!** Turn the Switch OFF (O) and disconnect the Power Cord. If the Grill is still hot, allow it to thoroughly cool. Open the Door and remove all food, the Porcelain Grills, Grease Drain Pan and the Heat Baffle.

b) **WARNING!** Remove all unburned pellets and ash from inside and around the Firepot. (See instructions for proper handling and disposal of ash in Section 5)

c) Before replacing the Heat Baffle, Grease Drain Pan and the Porcelain Grills, plug the Power Cord into an appropriate, grounded electrical outlet and turn the Switch ON (I). Pellets should fall into the Firepot and the Hot Rod should begin to heat (it will start to turn red). **CAUTION!** Do not touch it.

d) If this procedure is successful, you will soon see flames come out of the Firepot. Then turn the Switch OFF (O), and let the Grill cool down. Position the Heat Baffle, the Grease Drain Pan and Porcelain Grills in their proper locations.

With the Door open, turn the Switch ON(I) and the Temperature/Dial to SMOKE. In approximately 2 minutes you will notice whitish-gray smoke coming out of the Grill as the Pellets ignite. After assuring the Pellets have ignited, close the Door and set the Temperature/Dial to any cooking setting desired.

e) If this didn't remedy the problem, contact Smokey Bandit Technical Support(Section Seven) for additional troubleshooting help.

5.WITH THE SMOKEY BANDIT DIGITAL CONTROL ,WHAT DIAL SETTING IS RECOMMENDED FOR STARTING THE GRILL?

The auto-start procedure is the same for all Grill Controls. With the Door open, turn the Switch ON (I) and the Temperature/Dial to SMOKE. In approximately 2 minutes you will notice whitish-gray smoke coming out of the Grill as the Pellets ignite. After assuring the Pellets have ignited, close the Door and set the Temperature Dial to any cooking setting desired.

6.WHAT TEMPERATURE SETTINGS DO I USE WITH MY DIGITAL THERMOSTATCONTROL WHEN THE COOKBOOK RECIPES CALL FOR SMOKE, MEDIUM ANDHIGH?

This handy conversion chart will help you determine where to set the Thermostat when the recipes call for “Smoke”, “Medium” or “High” settings with the 3-Speed Smoker Control. Remember: Grill temperature is affected by conditions such as outside temperature, precipitation and wind as well as altitude. Please keep this in mind when determining how long it will take food to cook on your Grill.

7.HOW DO I PROTECT MY PAINT FINISH?

1. Use a protective Cover on the Grill and touch-up paint to repair any scratches. Smokey Bandit to protect the Grill is highly recommended! Covers and touch-up paint are available from your Dealer, or log on to our Web Site – www.smokeybanditbbq.nl.

2. Every 90 days, use a high quality car wax on the outside surfaces of the Grill. ONLY APPLY WAX TO A COLD GRILL.

DIGITAL THERMOSTAT CONTROL WIRING DIAGRAM

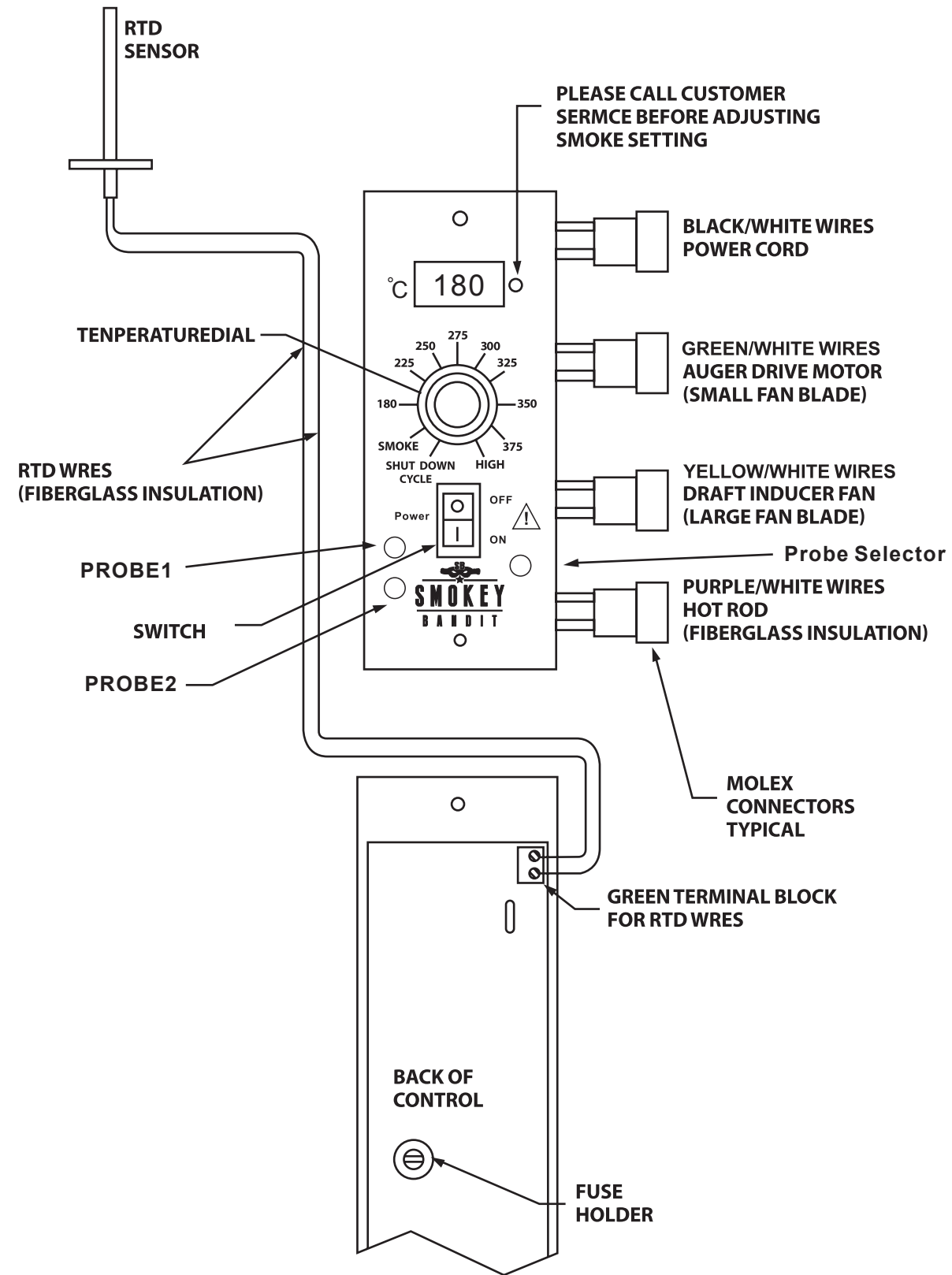

SECTION 7: SMOKEY BANDIT SUPPORT

Parts are identified in the front of this manual on the COMPONENT DIAGRAM PAGE.

To order parts: Call, E-mail or write to your Smokey Bandit BBQ. Please provide your name, phone number, address, Model and Serial Number of the Grill, along with the part identification

SMOKEY BANDIT BBQ CUSTOMER SERVICE
 MON TO FRI, 8:00 A. M. -5:00P. M. Central European Time.
 CONTACT: Tel+31(0)6 54350607
 EMAIL: info@smokeybanditbbq.nl
 WEBSITE: www.smokeybanditbbq.nl