

CONSTIX™ Swab, SP-11

Double layer sealed knit polyester

Description

CONSTIX SP-11 sealed polyester swab consists of 100% knit polyester fabric that's thermally bonded to a rigid polypropylene handle. The cleanroom laundered, double layer knit polyester head provides enhanced sorbency, particle entrapment, and residue removal. The head is constructed without adhesives or binders, which makes the swab compatible with most common solvents, such as alcohols and ketones. The polypropylene handle has a thin tip that enables access to very small areas and components. The swab is durable, absorbent and features extremely low particles and residue levels.

Technical Data

Swab head material	Knit polyester
Swab handle material	Polypropylene
Construction	Thermally sealed and attached

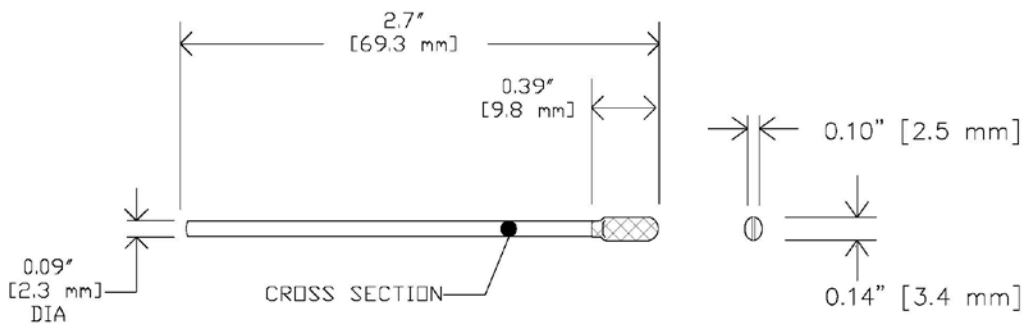

Notes:

- 1) Data shown are typical values and should not be used as product specifications.
- 2) Valid product comparisons may only be obtained through side-by-side testing in the same test facility, under similar conditions.
- 3) Current and/or comparison data may be available. Please contact a Contec sales representative for details.

Revision date: 02/23/17



Copyright © 2017 Contec, Inc. All rights reserved.

