

# euroseats

Item No. : 75.BUR.001  
Installation guide

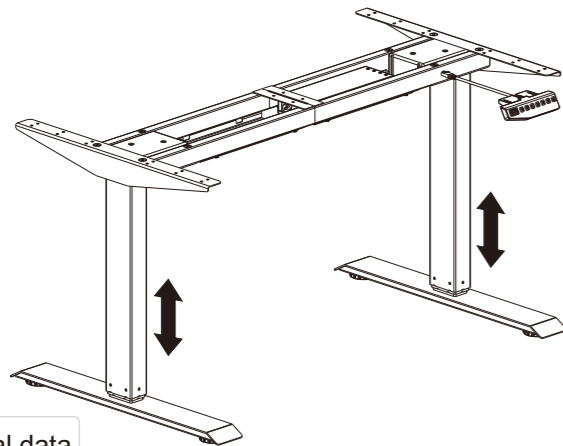

### Accessory list

Attention: The drawings below are only for reference which might be slightly different from the actual object, please in kind prevail. Any tools missing or installation problems, please contact the customer service firstly.

No.	Image	Spec	Qty
A		M6x16mm	8
B		ST4.2x20mm	26
C		M8x35mm	8
D		Square spacer	6
E		Wrench 4x4mm    Wrench 5x5mm	1 per wrench

### Technical data

Column stage	3 stage	Input Voltage	100-240V
Max Loading capacity	125KG	Max Speed	38mm/s
Height range	620-1250mm	Temperature	0-40°C
Length range	1100-1800mm	Certification	CE FCC CUL
Duty cycle	10%(continuous operation for 2 mins at most after pause for 18 mins)		

### Component list

No.	Part	Qty	No.	Part	Qty
①	Pedestal	2	②	Lifting Column	2
③	Supporting beam	1	④	Cable management	2
⑤	Supporting plate	2	⑥	Control box	1
⑦	Handswitch	1	⑧	Power cable	1

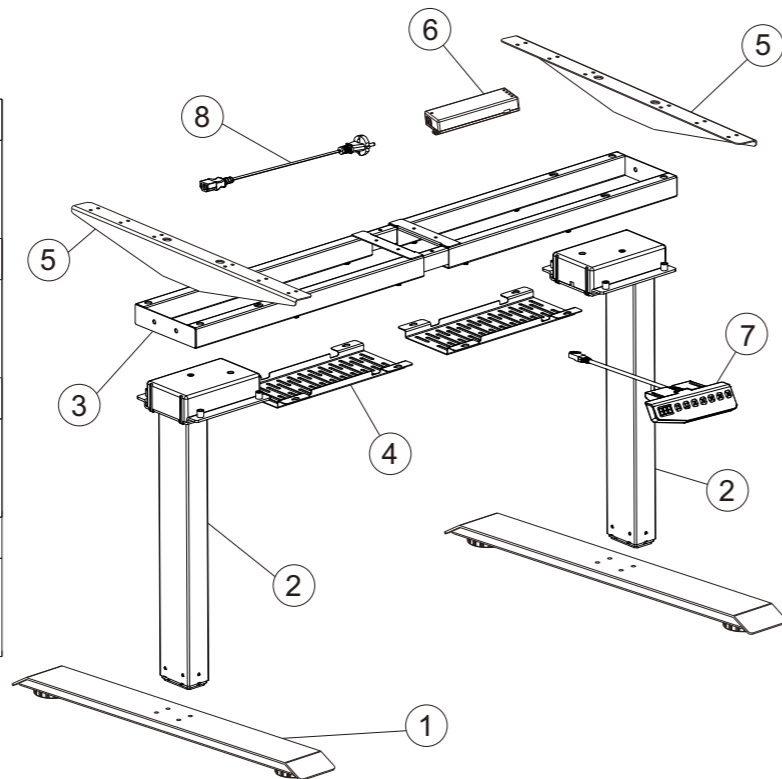

### STEP 1

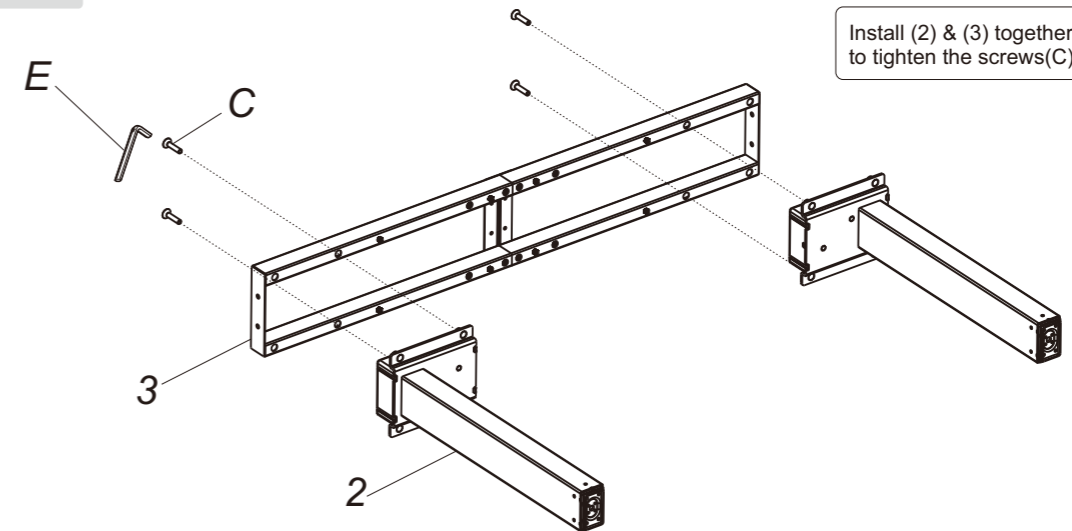

Install (2) & (3) together, use 5\*5 wrench(E) to tighten the screws(C).

### STEP 2

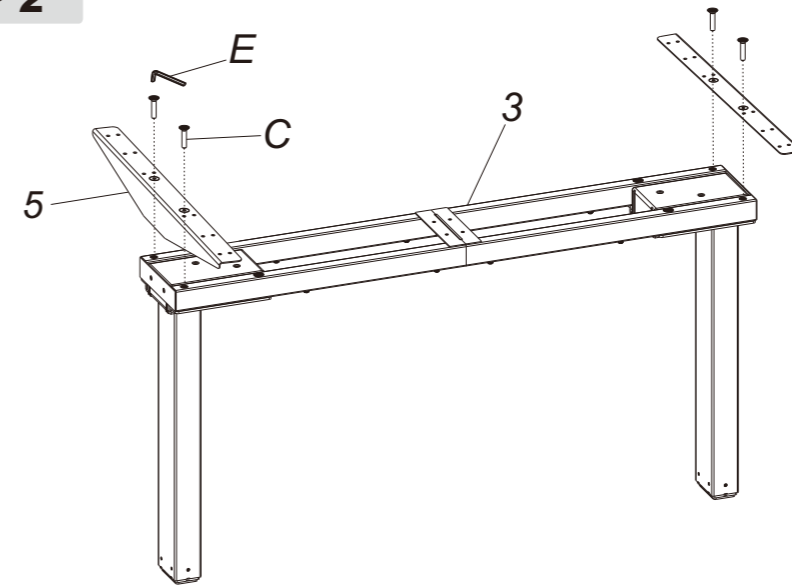

Install (5) & (3) together, use 5\*5 wrench(E) to tighten the screws(C).

### STEP 3

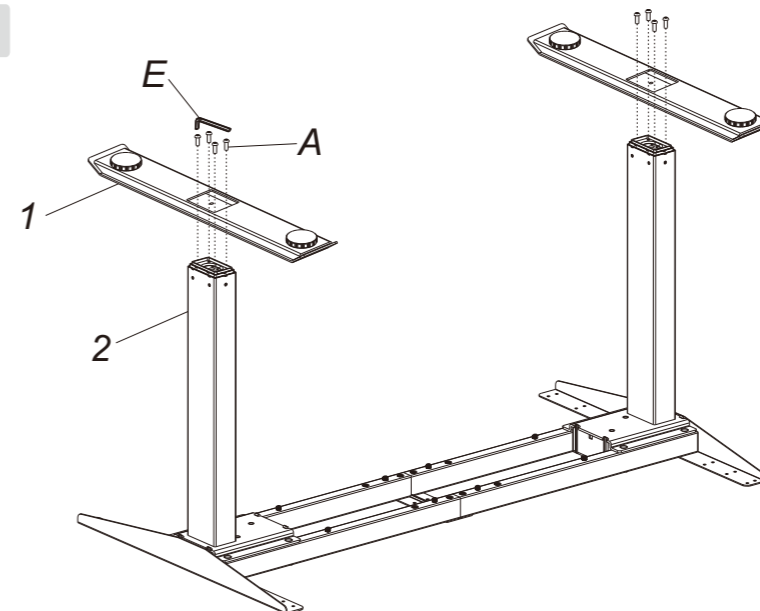

Install (2) & (1) together, use 4\*4 wrench(E) to tighten the screws(A).

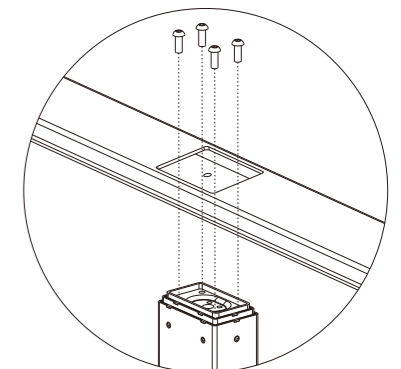

## STEP 4

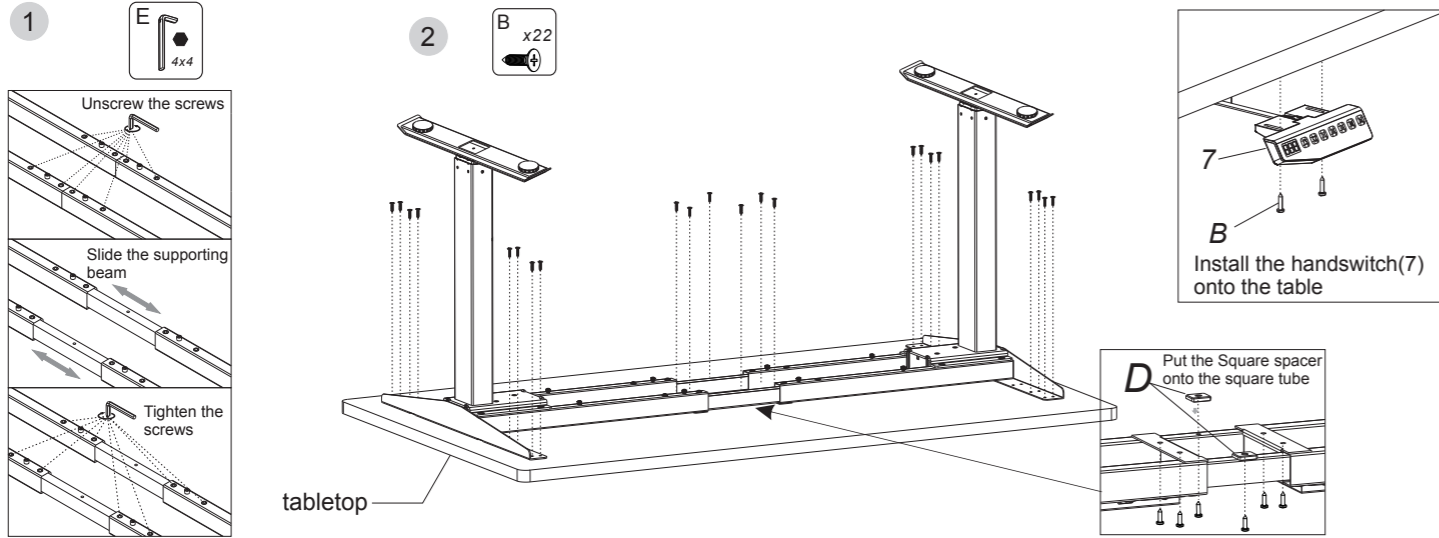

## How to use handswitch

Button

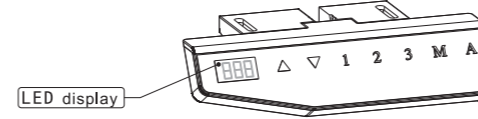

●	“▲”	Adjust the desk upwards
●	“▼”	Adjust the desk downwards
●	“1”	Position 1, first height position saved by user
●	“2”	Position 2, second height position saved by user
●	“3”	Position 3, third height position saved by user
●	“M”	Memory button for height memory function
●	“A”	Alarm button for reminding of keeping same position for long time

## Instruction

- Press the UP button or DOWN button to lift or lower the height of desk surface. The LED display shows the real time value. The range of the height value: 62.0cm-125cm.
- Saving A Height Position
  - Press the UP button or DOWN button to lift or lower the height of desk surface. For instance, you adjust the height to 80cm.
  - Press "M" SAVE button and the LED display shows "5-1", then press "1" to save the 1st height position to 80cm. The LED display shows "5-1".
  - Repeat step a and step b to save the 2nd height position to 100cm. The LED display shows "5-2". Save the 3rd height position to 120cm. The LED display shows "5-3".
  - Press "1", "2", "3", to automatically reach the height saved before.
- Long-Time Sitting Reminder
  - Press REMINDER button "A" to activate the function. The LED display shows "00".
  - Two seconds later, press the "▲" or "▼" button to adjust the reminder time only when the display screen flashes. Then press any button to save the time setup, or wait 5 seconds and system will save the time setup automatically. During the countdown, any operation will lead to a repeat starting of the timer. When the countdown finishes, the buzzer will be active with a 10-second "DiDi...DiDi...DiDi..." tone.
  - Within the 10-second reminder buzz, press any button to reactivate the time countdown that is set up in (b) step. If no operation during the 10-second reminder buzz, there will be another reminder buzz after 5 minutes. No operation during the second buzz will turn off the Long-Time Sitting Reminder.
  - Press and hold the "A" button for three seconds to turn off the Long-Time Sitting Reminder. The LED display shows "0FF".
- Troubleshooting
  - When meet any problem, press "▼" button to reset and LED will show "95r". Then press and hold the "▼" button until the desk reaches its lowest height and rebound to 60cm and display shows "60", which means the reset process finished.
  - If the "▼" button doesn't work, please check the cable connection and then cut off the power for at least 10 seconds. Reconnect to the power and press "▼" button to start the reset process. If it still doesn't work, please retry 18 mins later. (Please avoid overtime working for more than 2 mins.)
- Anti-Collision System (15kg)
 

During height adjustment, when tabletop comes in contact with another object, it will instantly stops and reverses 4cm to avoid damage.

## STEP 5

Connect all the cables onto the control box(6)

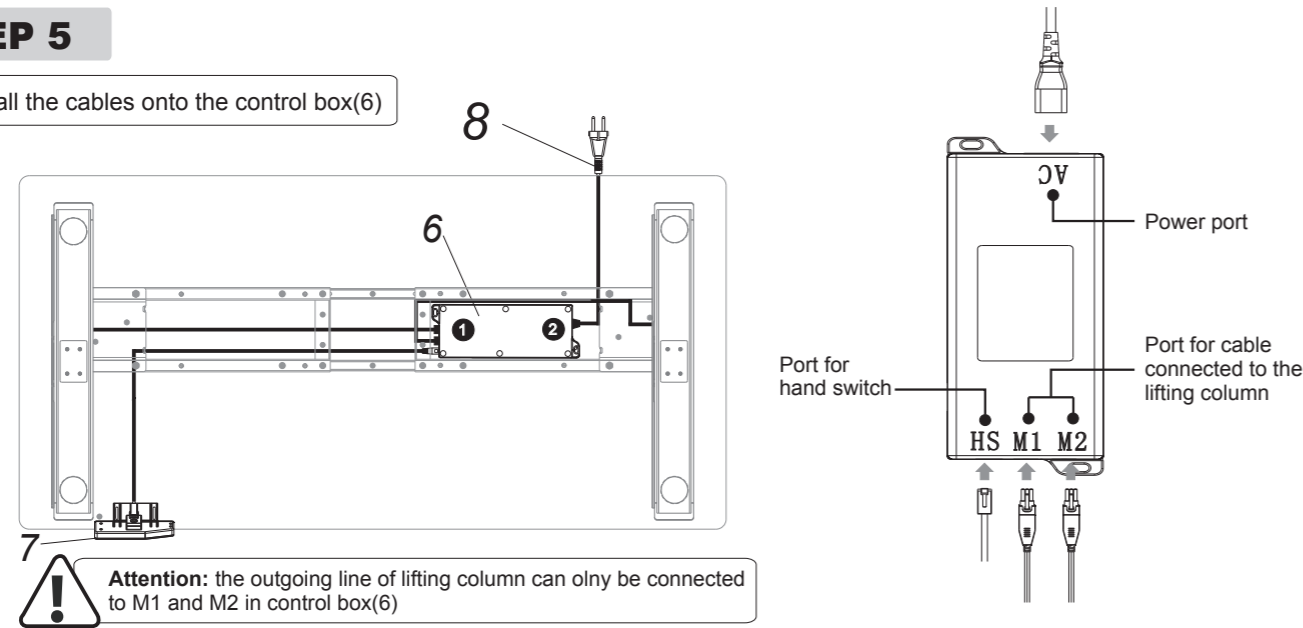

## Common fault treatment

The following tips will help you detected and eliminate the common fault and error. If the fault you met is not listed below, please contact with your supplier. Only the manufacturer and professionals are capable for investigating and correcting those fault and error.

Fault phenomenon	Method
No response while long pressing down arrow after connected with a power supply	1. Check if all the cables be connected well 2. Contact your supplier or dealer
No response while pressing up arrow/ down arrow after connected with a power supply	1. Check if all the cables be connected well 2. Contact your supplier or dealer
Rising in a low speed	1. Check if overloaded, max loading: 125kg; 2. Contact your supplier or dealer
The motor not move as instructed	1. Contact your supplier or dealer
Go down but not go up	1. Reposition 2. Contact your supplier or dealer
Downward sliding	1. Check if overloaded, max loading: 125kg; 2. Contact your supplier or dealer
Frequently Reposition	1. Check if overloaded, max loading: 125kg; 2. Contact your supplier or dealer
Overwork (Duty cycle: Max 2min on/18min OFF)	1. Restart after suspend for 18mins while connecting with power; 2. Contact your supplier or dealer;
Not enough up&down height	1. Press "M" and "3" together for 3 seconds or more, after hearing continuous beeping for twice, it will restore factory settings. 2. Contact your supplier or dealer



## Attention

- Power supply: AC 100V-240V, 50/60HZ
- Service Environment: 0-40°C
- Unplug the power plug before cleaning, wipe the dust on surface with slight wet dishcloth when cleaning, be careful not to let the drops into the internal parts, not loose the connector.
- The electric box contains electronic components, metals, plastics, wires etc., so dispose of it in accordance with each country's environmental legislation, not the general household waste.
- Check carefully to ensure correct and complete assembly before using.
- Be familiar with all functions and program settings of the product before first use.
- Children are forbidden to play on the product because of unforeseen action when playing, so any dangerous consequences caused by this improper action will not be on
- Slight noise caused by the V-ribbed belt or brake system due to structure will not have any effect on the use of the equipment.
- Corrosive or abrasive materials are forbidden to clean the equipment. Must ensure that the cleaner used will not pollute the environment.
- This appliance can be used by children aged from 8 years and above and persons with reduced physical, sensory or mental capabilities or lack of experience and knowledge if they have been given supervision or instruction concerning use of the appliance in a safe way and understand the hazards involved. Children shall not play with the appliance.
- Cleaning and user maintenance shall not be made by children without supervision.
- If the supply cord is damaged, it must be replaced by the manufacturer, its service agent or a similarly qualified person in order to avoid a hazard.
- Please make sure there is no hazard sources in your operating environment, e.g., do not litter the tools around. Always be careful to treat the packaging materials in order to avoid any possible danger, e.g. plastic bag may lead to choking hazard to children.
- Keep the original package of the equipment if necessary in case of the future use in transportation.

## STEP 6

Install cable management

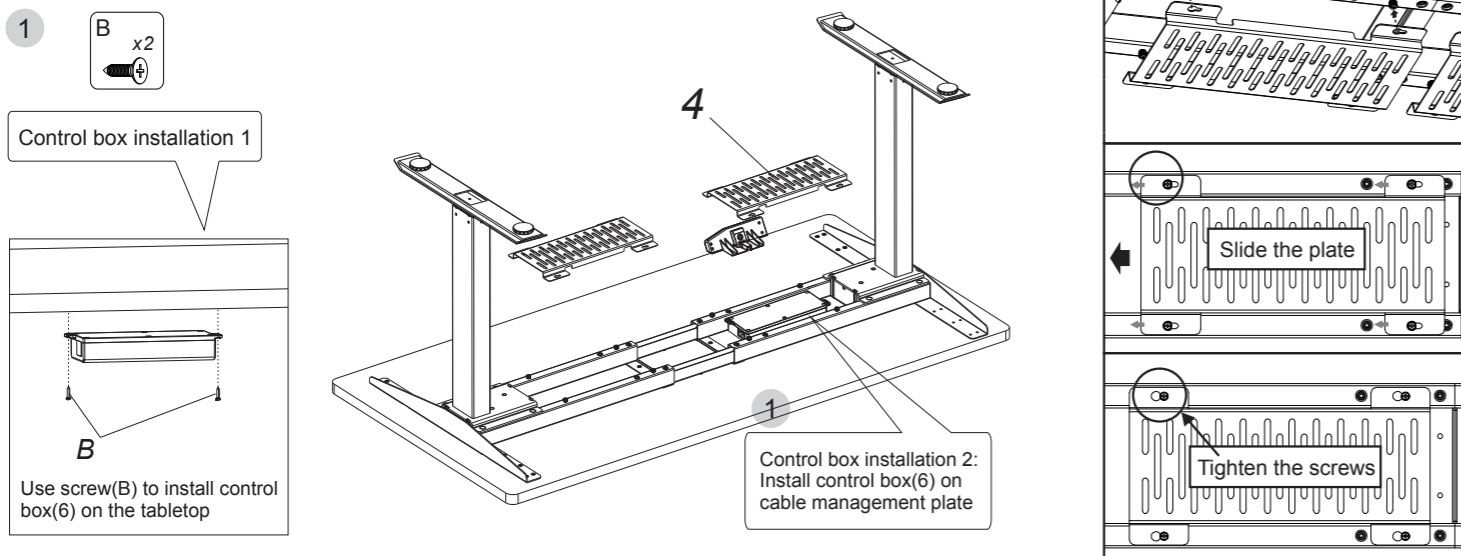

## Waste disposal



This marking indicates that this product should not be disposed with other household wastes. To prevent possible harm to the environment or human health from uncontrolled waste disposal, recycle it responsibly to promote the sustainable reuse of material resources. To return your used device, please use the return and collection systems or contact the retailer where the product was purchased. They can take this product for environmental safe recycling.