

KIDS CHAIR

What's in the box?

- 4x Legs A
- 3x beam B
- 1x handle C
- 2x Bottom beam D

Caution! Fold towards the folding lines.

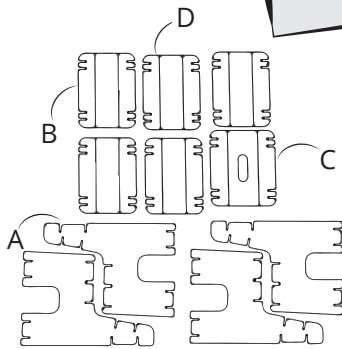

1. Check if you have all parts.

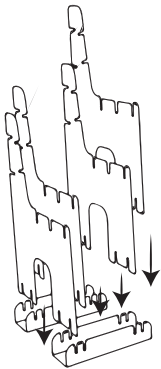

3. Take the four legs A and slide them into the bottom beams B, as shown in the image.

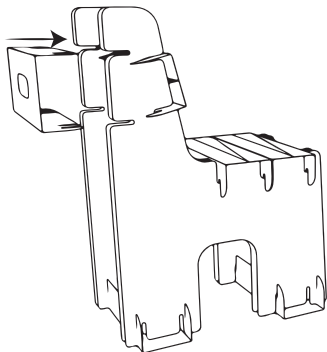

5. Finally, slide handle C into the notches of the legs, as shown in the image. The chair is finished!

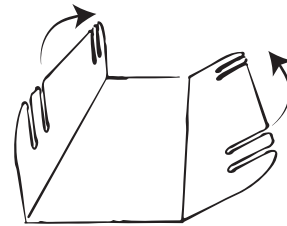
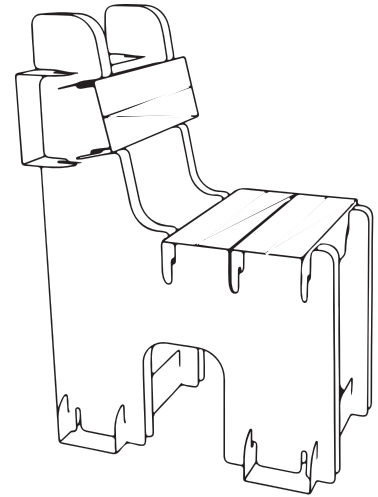

6x

2. Fold beams B, bottom beams D and handle C.

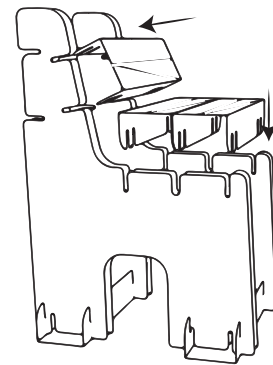

4. Slide the three beams B into the notches in the legs, as shown in the image.