

**TecnoAir** | idee  
**System** | per vivere  
meglio



## **RUBY**

BIOCAMINI COLLEZIONE 2022 – 23  
Design Arch. Piervittorio Prevedello

Da oltre 30 anni, Tecno Air System è specializzata nella commercializzazione di prodotti per il riscaldamento domestico ed oggettistica d'arredo. La sua mission è offrire al mercato prodotti smart, compatibili con un'economia verde, accessibili e pratici.

Il settore è competitivo, vince chi riesce a proporre soluzioni sempre originali, che incontrano i gusti ed i budget dei consumatori. Negli anni Tecno Air System si è affermata come azienda leader grazie allo sviluppo di un processo produttivo e organizzativo che garantisce flessibilità, tempi rapidi ed innovazione continua.

La struttura aziendale è organizzata per rispondere alle specifiche esigenze della rete vendita. Una vasta gamma di prodotti permette di scegliere delle linee specifiche da presentare nei negozi, rispondendo sia alla richiesta di prodotti per il riscaldamento degli ambienti, sia a quella prettamente decorativa. I modelli sono vari, da quelli mini ai formati più scenografici, e tutti si distinguono per la praticità di utilizzo e di manutenzione. Uno showroom dedicato all'interno dell'azienda è sempre disponibile per vedere dal vivo le anteprime e tutti i modelli presenti sul mercato.

La logistica è organizzata e il magazzino sempre ben fornito così che gli ordini, di qualsiasi entità, possono essere evasi in tempi rapidi e le consegne sono gestite tramite un sistema collaudato che permette di raggiungere in pochi giorni qualsiasi angolo del mondo.

Tecno Air System si avvale di uno staff commerciale e tecnico capace di dare assistenza tempestiva sia nella logistica, sia nella soluzione di problematiche commerciali e tecniche. Tecno Air System offre un'analisi del mercato sempre aggiornata sullo sviluppo delle vendite e sui punti di crescita del settore.

Since over 30 years, Tecno Air System has specialized on sales of heaters equipment and decorative products. Its mission is to offer on the market smart products, all those compatible with the green economy.

This kind of business is high competitive and to be able to win Tecno Air System has to propose original solutions meeting the consumers tastes and reaching in this way important targets. All of over the years Tecno Air System has established itself as a leader company through the organization of the production and management development ensuring flexibility, fast delivery times and continuous innovation.

The company structure has managed to meet the specific needs of the market networks. A large range of products allows you to choose specific styles to introduce on the stores in order to comply all requests for heaters or simply decorative products. The models are various, from the little ones to more scenographics formats. All of them are distinguished by easy use and reduced maintenance too. A dedicated showroom is always available to see the market preview and all of products ranges.

The logistics has best well organized and the warehouse, as well, has always well stocked in order to fulfill quickly the orders process and delivery of the goods will be able to reach any place of the world.

Tecno Air System through a commercial and technical staff it's be able to give fast assistance and solution to resolve commercial and technical questions. Tecno Air System also provides offering a commercial analysis always updated on the development of this business market area.

**Piervittorio Prevedello.** Dopo la laurea allo Iuav di Venezia, frequenta una summer session alla Domus Accademy di Milano frequentando i corsi di Antonio Citterio, Ron Arad, Isao Hosoe, Constantin Grcic, Maiko Hasuike e Stefano Giovannoni. La collaborazione più che decennale con gli architetti Afra e Tobia Scarpa e Fabio Lombardo, gli consente di lavorare a stretto contatto con le più importanti aziende del settore furniture: Unifor, B&B, Maxalto, Molteni, e Flos, nonché a progetti sia di architettura (residenze private), che industriale (polo produttivo del gruppo Benetton a Castrette di Villorba). Svolge la propria attività professionale di design consultant e industrial designer per Bonaldo, Cattelan Italia, Infiniti design e Tonin Casa. Nel 2004, con lo pseudonimo di Glenn Thomas, vince il "The Good Award Design" Chicago Athenaeum, con il divano Pierrot per Bonaldo. Nel 2014 vince il "The Good Award Design" Chicago Athenaeum e il Red Dot Award con il tavolo Mat per OMP Group-Infiniti Design. Nel 2019, vince il "The Good Award Design" con i bio-camini Osaka e Rialto per Tecno Air System.

After his degree from Iuav university in Venice, he attends at Domus Academy in Milan, taking the courses of Antonio Citterio, Ron Arad, Isao Hosoe, Constantin Grcic, Maiko Hasuike and Stefano Giovannoni. The more than a ten-year partnership with architects Afra and Tobia Scarpa and Fabio Lombardo enables him to work closely with the most important companies in the furniture field such as Unifor, B&B, Maxalto, Molteni, and Flos as well as architectural projects (private residences) and industrial projects (Benetton group's production site in Castrette di Villorba). He carries out his professional activity as a design consultant and industrial designer for Bonaldo, Cattelan Italia, Infiniti design and Tonin Casa.

In 2004, under the pseudonym of Glenn Thomas, he wins "The Good Award Design" Chicago Athenaeum, with the sofa Pierrot for Bonaldo. In 2014 he wins "The Good Award Design" Chicago Athenaeum and the Red Dot Award with the table Mat for OMP Group-Infiniti Design. In 2019, he wins the "The Good Award Design" with the Osaka and Rialto bio-fireplaces for Tecno Air System.

**Giacomo Buonanno.** Nel 1989 ha fondato la Tecno Air System (TAS) rendendola ben presto azienda di riferimento nell'ambito delle stufe a combustibile liquido. Nel 2005 l'azienda viene acquisita dal gruppo belga Essegè Group, allargandone esponenzialmente i mercati. Giacomo Buonanno in TAS mantiene il suo ruolo di CEO e nel 2011, accogliendo la sensibilità verso i temi ambientali, include nella gamma le Biostufe e i Biocamini alimentati da fonti rinnovabili, diventando leader nel mercato italiano. Il 2019 si apre con un progetto che unisce l'imprenditorialità dell'azienda alla creatività dei designer italiani. Convinto che il design contribuisca ad accrescere il sentimento del bello e a creare un atteggiamento nuovo che aiuti a ridisegnare la società, ha avviato la collaborazione con l'architetto Piervittorio Prevedello realizzando una nuova linea di Biocamini di design e in linea con le esigenze di sostenibilità ambientale.

He founded Tecno Air System in 1989, making it soon the main company on the liquid fuel stoves. In 2005 the company has been bought by a Belgium Group Essegè SA, that was going to grow its business. Giacomo Buonanno has kept the CEO figure in TecnoAirSystem and in 2011 following the feeling about the environmental matters he has extended the products range with the renewable sources fireplaces becoming a leader on the Italian market.

In 2019 he has started with a project joining the Italian Entrepreneurship with the creativity of the Italian designers. Sure that the design could help to increase the feeling of the beauty and to create a new attitude to redesign the community he has started a partnership with the Architect Piervittorio Prevedello creating a new line of design fireplaces in according to the environmental sustainability needs.





#### **Biocamini da Tavolo**

Boston	06
Rialto	08
Mantova	10
Lione	12
Bilbao	14
York	16
Aosta	18
Cremona	22
Oslo	26

#### **Biocamini da Pavimento**

Tokyo	28
Osaka	30
Shanghai	32
Kyoto	34
Portofino	36
Cervinia	38
Conegliano	40
Firenze	42
Udine	44
Dubai	46
Falcade	50
Matera	52
Camogli	54
Nairobi	56
Roma	58
Cortina	60
Bologna	64
Trento	66

#### **Biocamini da Parete**

Elysium	68
Verona	70
Treviso	76
Palmanova	82
Altea	84

#### **Product Launch**

Giga	86
Delta	88
Rialto Wall	94
OpenClosed	96

# Boston

Biocamino da tavolo. Struttura in acciaio verniciato e vetro. Bruciatore removibile con fibra e coperchio di chiusura fiamma.

Table bioethanol fireplace. Painted stainless steel and glass structure. Burner removable with fiber and flame closing cover

Cheminée de table. Structure en acier peint et verre. Brûleur amovible cylindrique avec fibre et tige stop brûleur.

Chimenea de sobremesa. Estructura en acero pintado y vidrio. Quemador desmontable con fibra y tapa de cierre de llama.



Dimensioni / dim. (H x L x P)	180 x 598 x 304 mm
Peso Netto / net weight / poids / peso	4,5 kg
Bruciatore / burner / brûleur / quemador	0,4 lt
Potenza / power / puissance / potencia	1,2 kw
Garanzia / warranty / garantie / garantía	2 anni + 1 anno / year Ethaline*

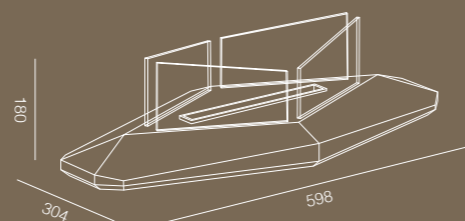

\* Ethaline ti allunga la garanzia di 12 mesi



# Rialto

Biocamino da tavolo. Struttura in acciaio verniciato e vetro. Bruciatore removibile con fibra e coperchio di chiusura fiamma

Table bioethanol fireplace. Painted stainless steel and glass structure. Burner removable with fiber and flame closing cover.

Cheminée de table. Structure en acier peint et verre. Brûleur amovible cylindrique avec fibres et tige stop brûleur

Chimenea de sobremesa. Estructura en acero pintado y vidrio. Quemador desmontable con fibra y tapa de cierre de llama.



Dimensioni / dim. (H x L x P)	276 x 860 x 390 mm
Peso Netto / net weight / poids / peso	10 kg
Bruciatore / burner / brûleur / quemador	2,2 lt
Potenza / power / puissance / potencia	2,0 kw
Garanzia / warranty / garantie / garantía	2 anni + 1 anno / year Ethaline*

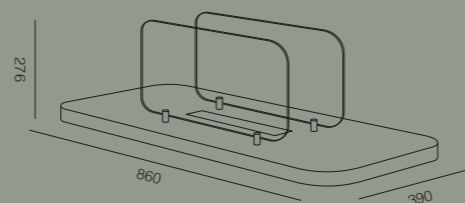

\* Ethaline ti allunga la garanzia di 12 mesi



# Mantova

Biocamino da tavolo. Struttura in acciaio e vetro. Bruciatore removibile e regolabile con fibra.

Table bioethanol fireplace. Painted stainless steel and glass structure. Burner removable with fiber and flame closing cover.

Cheminée de table. Structure en acier peint et verre. Brûleur amovible cylindrique avec fibre et tige stop brûleur.

Chimenea de sobremesa estructura en acero pintado y vidrio. Quemador desmontable con fibra y tapa de cierre de llama.



Dimensioni / dim. (H x L x P)	350 x 600 x 200 mm
Peso Netto / net weight / poids / peso	9 kg
Bruciatore / burner / brûleur / quemador	1,5 lt
Potenza / power / puissance / potencia	2,0 kw
Garanzia / warranty / garantie / garantía	2 anni + 1 anno / year Ethaline*

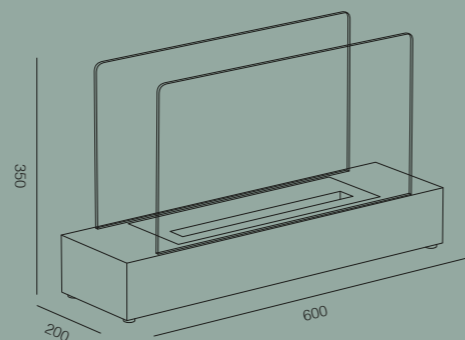

\* Ethaline ti allunga la garanzia di 12 mesi



# Lione

Biocamino da tavolo. Struttura in acciaio verniciato e vetro. Bruciatore removibile con fibra e coperchio di chiusura fiamma

Table bioethanol fireplace. Painted stainless steel and glass structure. Burner removable with fiber and flame closing cover

Cheminée de table. Structure en acier peint et verre. Brûleur amovible cylindrique avec fibres et tige stop brûleur.

Chimenea de sobremesa. Estructura en acero pintado y vidrio. Quemador desmontable con fibra y tapa de cierre de llama.



Dimensioni / dim. (H x Ø)	234 x 284 mm
Peso Netto / net weight / poids / peso	3,60 kg
Bruciatore / burner / brûleur / quemador	0,3 lt
Potenza / power / puissance / potencia	0,5 kw
Garanzia / warranty / garantie / garantía	2 anni + 1 anno / year Ethaline*

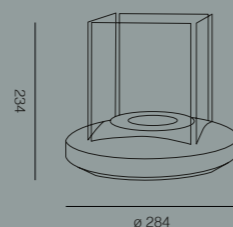

\* Ethaline ti allunga la garanzia di 12 mesi





# Bilbao

Biocamino da tavolo. Struttura in acciaio verniciato e vetro. Bruciatore removibile con fibra e coperchio di chiusura fiamma.

Table bioethanol fireplace. Painted stainless steel and glass structure. Burner removable with fiber and flame closing cover.

Cheminée de table. Structure en acier peint et verre. Brûleur amovible cylindrique avec fibres et tige stop brûleur.

Chimenea de sobremesa. Estructura en acero pintado y vidrio. Quemador desmontable con fibra y tapa de cierre de llama.



Dimensioni / dim. (H x Ø)	265 x 240 mm
Peso Netto / net weight / poids / peso	2,40 kg
Bruciatore / burner / brûleur / quemador	0,3 lt
Potenza / power / puissance / potencia	0,5 kw
Garanzia / warranty / garantie / garantía	2 anni + 1 anno / year Ethaline*

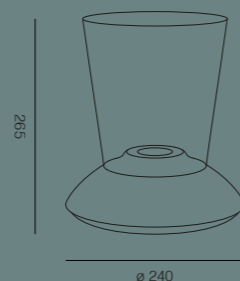

\* Ethaline ti allunga la garanzia di 12 mesi



# York

Biocamino da tavolo. Struttura in acciaio verniciato. Bruciatore removibile con fibra e coperchio di chiusura fiamma

Table bioethanol fireplace. Painted stainless steel. Burner removable with fiber and flame closing cover.

Cheminée de table. Structure en acier peint. Brûleur amovible cylindrique avec fibres et tige stop brûleur.

Chimenea de sobremesa. Estructura en acero pintado. Quemador desmontable con fibra y tapa de cierre de llama.



Dimensioni / dim. (H x Ø)	295 x 208 mm
Peso Netto / net weight / poids / peso	1,00 kg
Bruciatore / burner / brûleur / quemador	0,3 lt
Potenza / power / puissance / potencia	0,5 kw
Garanzia / warranty / garantie / garantía	2 anni + 1 anno / year Ethaline*

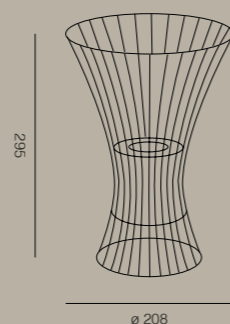

\* Ethaline ti allunga la garanzia di 12 mesi



# Aosta

Biocamino da tavolo. Struttura in acciaio verniciato e vetro. Bruciatore removibile con fibra e coperchio di chiusura fiamma.

Table bioethanol fireplace. Painted stainless steel and glass structure. Burner removable with fiber and flame closing cover.

Cheminée de table. Structure en acier peint et verre. Brûleur amovible cylindrique avec fibre et tige stop brûleur.

Chimenea de sobremesa. Estructura en acero pintado y vidrio. Quemador desmontable con fibra y tapa de cierre de llama.



Dimensioni / dim. (H x L x P)	350 x 180 x 180 mm
Peso Netto / net weight / poids / peso	4 kg
Bruciatore / burner / brûleur / quemador	0,4 lt
Potenza / power / puissance / potencia	0,8 kw
Garanzia / warranty / garantie / garantía	2 anni + 1 anno / year Ethaline*

\* Ethaline ti allunga la garanzia di 12 mesi

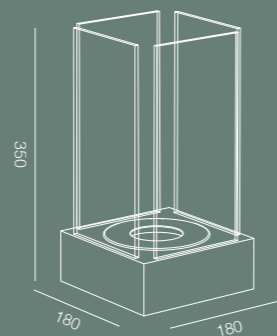

# Aosta

Biocamino da tavolo. Struttura in acciaio inox e vetro. Bruciatore removibile con fibra e coperchio di chiusura fiamma.

Table bioethanol fireplace. Stainless steel and glass structure. Burner removable with fiber and flame closing cover.

Cheminée de table. Structure en acier inoxydable et verre. Brûleur amovible cylindrique avec fibre et tige stop brûleur.

Chimenea de sobremesa. Estructura en acero inoxidable y vidrio. Quemador desmontable con fibra y tapa de cierre de llama.



Dimensioni / dim. (H x L x P)	350 x 180 x 180 mm
Peso Netto / net weight / poids / peso	4 kg
Bruciatore / burner / brûleur / quemador	0,4 lt
Potenza / power / puissance / potencia	0,8 kw
Garanzia / warranty / garantie / garantía	2 anni + 1 anno / year Ethaline*

\* Ethaline ti allunga la garanzia di 12 mesi

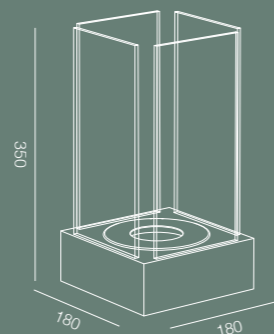

# Cremona

Biocamino da tavolo. Struttura in acciaio e vetro. Bruciatore removibile e regolabile con fibra.

Table bioethanol fireplace. Painted stainless steel and glass structure. Burner removable with fiber and flame closing cover.

Cheminée de table. Structure en acier peint et verre. Brûleur amovible cylindrique avec fibre et tige stop brûleur.

Chimenea de sobremesa. Estructura en acero pintado y vidrio. Quemador desmontable con fibra y tapa de cierre de llama.



Dimensioni / dim. (H x L x P)	240 x 400 x 165 mm
Peso Netto / net weight / poids / peso	5 kg
Bruciatore / burner / brûleur / quemador	1 lt
Potenza / power / puissance / potencia	1,5 kw
Garanzia / warranty / garantie / garantía	2 anni + 1 anno / year Ethaline*

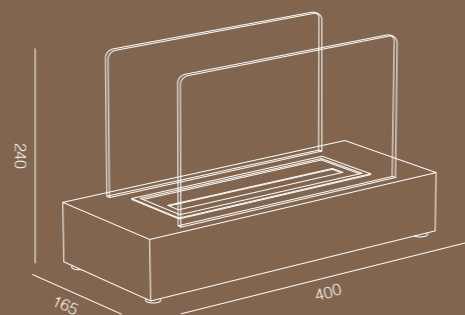

\* Ethaline ti allunga la garanzia di 12 mesi



# Cremona

Biocamino da tavolo. Struttura in acciaio e vetro. Bruciatore removibile e regolabile con fibra.

Table bioethanol fireplace. Painted stainless steel and glass structure. Burner removable with fiber and flame closing cover.

Cheminée de table. Structure en acier peint et verre. Brûleur amovible cylindrique avec fibre et tige stop brûleur.

Chimenea de sobremesa. Estructura en acero pintado y vidrio. Quemador desmontable con fibra y tapa de cierre de llama.



Dimensioni / dim. (H x L x P)	240 x 400 x 165 mm
Peso Netto / net weight / poids / peso	5 kg
Bruciatore / burner / brûleur / quemador	1 lt
Potenza / power / puissance / potencia	1,5 kw
Garanzia / warranty / garantie / garantía	2 anni + 1 anno / year Ethaline*

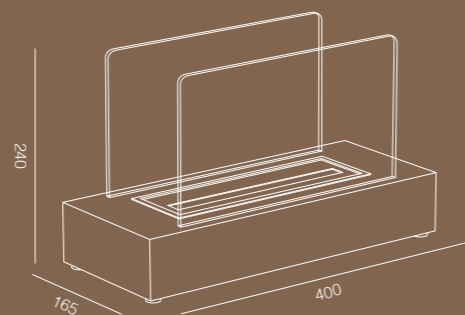

\* Ethaline ti allunga la garanzia di 12 mesi



# Oslo

Biocamino da tavolo. Struttura in acciaio verniciato e vetro. Bruciatore removibile con fibra e coperchio di chiusura fiamma.

Table bioethanol fireplace. Painted stainless steel and glass structure. Burner removable with fiber and flame closing cover.

Cheminée de table. Structure en acier peint et verre. Brûleur amovible cylindrique avec fibres et tige stop brûleur.

Chimenea de sobremesa. Estructura en acero pintado y vidrio. Quemador desmontable con fibra y tapa de cierre de llama.



Dimensioni / dim. (H x L x P)	280 x 185 x 185 mm
Peso Netto / net weight / poids / peso	2,5 kg
Bruciatore / burner / brûleur / quemador	0,3 lt
Potenza / power / puissance / potencia	0,5 kw
Garanzia / warranty / garantie / garantía	2 anni + 1 anno / year Ethaline*

\* Ethaline ti allunga la garanzia di 12 mesi

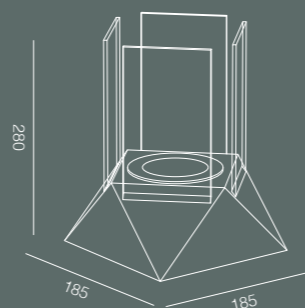

# Tokyo

Biocamino da pavimento. Struttura in acciaio verniciato e porta con vetro di protezione. Bruciatore removibile e regolabile con fibra

Free-standing bioethanol fireplace. Stainless steel structure and door with protective glass. Adjustable and removable burner with fiber.

Bio-cheminée de sol. Structure en acier peint et porte avec vitre de protection. Brûleur démontable y réglable en fibres.

Bio-chimenea de suelo. Estructura de acero pintado y puerta con cristal protector. Quemador amovible et regulable con fibra.



Dimensioni / dim. (H x L x P)	1235 x 456 x 400 mm
Peso Netto / net weight / poids / peso	32 kg
Bruciatore / burner / brûleur / quemador	2,0 lt
Potenza / power / puissance / potencia	3,0 kw
Garanzia / warranty / garantie / garantía	2 anni + 1 anno / year Ethaline*

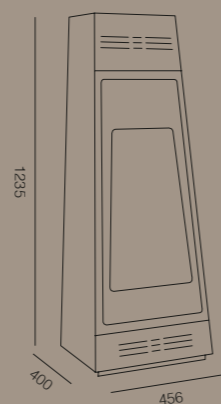

\* Ethaline ti allunga la garanzia di 12 mesi





# Osaka

Biocamino da pavimento. Struttura in acciaio verniciato e porta con vetro di protezione. Bruciatore removibile e regolabile con fibra.

Free-standing bioethanol fireplace. Stainless steel structure and door with protective glass. Adjustable and removable burner with fiber.

Bio-cheminée de sol. Structure en acier peint et porte avec vitre de protection. Brûleur démontable et réglable en fibres.

Bio-chimenea de suelo. Estructura de acero pintado y puerta con cristal protector. Quemador amovible et regulable con fibra.



Dimensioni / dim. (H x L x P)	1200 x 760 x 434 mm
Peso Netto / net weight / poids / peso	35 kg
Bruciatore / burner / brûleur / quemador	2,0 lt
Potenza / power / puissance / potencia	3,0 kw
Garanzia / warranty / garantie / garantía	2 anni + 1 anno / year Ethaline*

\* Ethaline ti allunga la garanzia di 12 mesi

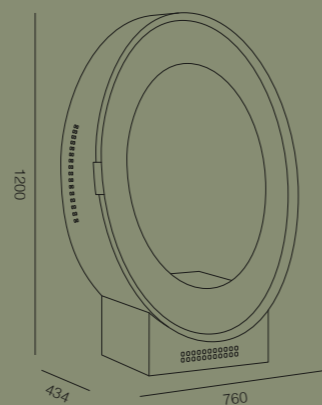

# Shanghai

Biocamino da pavimento. Struttura in acciaio verniciato e porta con vetro di protezione. Bruciatore removibile e regolabile con fibra.

Free-standing bioethanol fireplace. Stainless steel structure and door with protective glass. Adjustable and removable burner with fiber.

Bio-cheminée de sol. Structure en acier peint et porte avec vitre de protection. Brûleur démontable et réglable en fibres.

Bio-chimenea de suelo. Estructura de acero pintado y puerta con cristal protector. Quemador amovible et regulable con fibra.



Dimensioni / dim. (H x L x P)	1210 x 724 x 362 mm
Peso Netto / net weight / poids / peso	34 kg
Bruciatore / burner / brûleur / quemador	2,0 lt
Potenza / power / puissance / potencia	3,0 kw
Garanzia / warranty / garantie / garantía	2 anni + 1 anno / year Ethaline*

\* Ethaline ti allunga la garanzia di 12 mesi

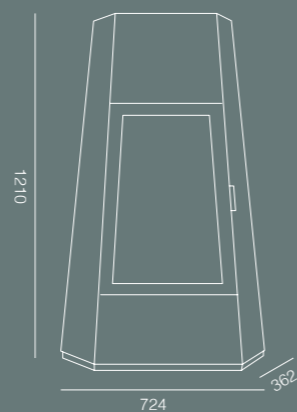

# Kyoto

Biocamino da pavimento. Struttura in acciaio verniciato e porta con vetro di protezione. Bruciatore removibile e regolabile con fibra.

Free-standing bioethanol fireplace. Stainless steel structure and door with protective glass. Adjustable and removable burner with fiber.

Bio-cheminée de sol. Structure en acier peint et porte avec vitre de protection. Brûleur démontable et réglable en fibres.

Bio-chimenea de suelo. Estructura de acero pintado y puerta con cristal protector. Quemador amovible et regulable con fibra.



Dimensioni / dim. (H x L x P)	930 x 656 x 415 mm
Peso Netto / net weight / poids / peso	36 kg
Bruciatore / burner / brûleur / quemador	1,5 lt
Potenza / power / puissance / potencia	3,0 kw
Garanzia / warranty / garantie / garantía	2 anni + 1 anno / year Ethaline*

\* Ethaline ti allunga la garanzia di 12 mesi

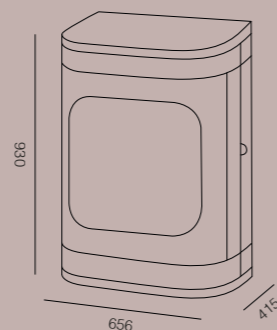

# Portofino

Biocamino da pavimento. Struttura in acciaio inox. Bruciatore removibile con fibra e coperchio di chiusura fiamma.

Free-standing bioethanol fireplace stainless steel structure. Burner removable with fiber and flame closing cover.

Cheminée au sol. Structure en acier inoxydable. Brûleur amovible cylindrique avec fibre et tige stop brûleur.

Chimenea de suelo. Estructura en acero inoxidable. Quemador desmontable con fibra y tapa de cierre de llama.



Dimensioni / dim. (H x L x P)	1800 x ø 330 mm
Peso Netto / net weight / poids / peso	45 kg
Bruciatore / burner / brûleur / quemador	2,2 lt
Potenza / power / puissance / potencia	2,0 kw
Garanzia / warranty / garantie / garantía	2 anni + 1 anno / year Ethaline*

\* Ethaline ti allunga la garanzia di 12 mesi

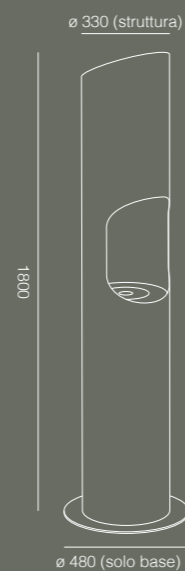

# Cervinia

Biocamino da soffitto. Struttura in acciaio verniciato. Bruciatore removibile e regolabile con fibra.

Ceilling bioethanol fireplace. Painted stainless steel structure. Adjustable and removable burner with fiber.

Cheminée au plafond. Structure en acier peint. Brûleur démontable y réglable avec fibre.

Chimenea de techo. Estructura en acero pintado. Quemador amovible et regulable con fibra.



Dimensioni / dim. (H x L x P)	1900 x 600 x 400 mm
Peso Netto / net weight / poids / peso	28 kg
Bruciatore / burner / brûleur / quemador	1,5 lt
Potenza / power / puissance / potencia	2,0 kw
Garanzia / warranty / garantie / garantía	2 anni + 1 anno / year Ethaline*

\* Ethaline ti allunga la garanzia di 12 mesi

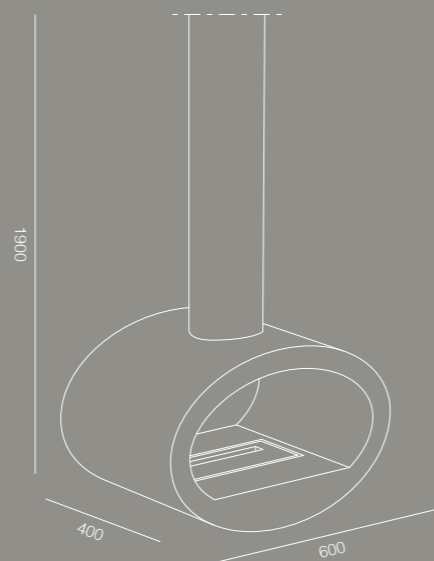

# Conegliano

Biocamino da pavimento. Struttura in legno verniciato bianco. Bruciatore removibile e regolabile con fibra.

Free-standing bioethanol fireplace white painted wooden structure. Adjustable and removable burner with fiber.

Bio-cheminée de sol. Structure en bois peint en blanc. Brûleur amovible et réglable avec fibre.

Bio-chimenea de suelo. Estructura de madera pintada de blanco. Quemador extraíble y ajustable con fibra.



Dimensioni / dim. (H x L x P)	970 x 960 x 350 mm
Peso Netto / net weight / poids / peso	43,5 kg
Bruciatore / burner / brûleur / quemador	1,8 lt
Potenza / power / puissance / potencia	2,5 kw
Garanzia / warranty / garantie / garantía	2 anni + 1 anno / year Ethaline*

\* Ethaline ti allunga la garanzia di 12 mesi

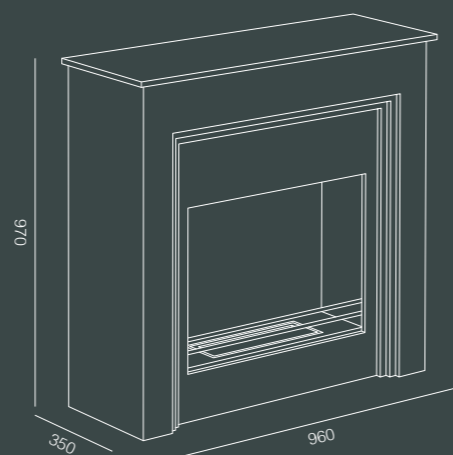

# Firenze

Biocamino da pavimento. Struttura in legno verniciato bianco. Bruciatore removibile e regolabile con fibra.

Free-standing bioethanol fireplace white painted wooden structure. Adjustable and removable burner with fiber.

Bio-cheminée de sol. Structure en bois peint en blanc. Brûleur amovible et réglable avec fibre.

Bio-chimenea de suelo. Estructura de madera pintada de blanco. Quemador extraíble y ajustable con fibra.



Vedi in Realtà Aumentata  
See in Augmented Reality  
Ver en Realidad Aumentada  
Voir en réalité augmentée



Conforme  
alla normativa  
EN 16647:2016

Dimensioni / dim. (H x L x P)	900 x 1000 x 300 mm
Peso Netto / net weight / poids / peso	33,2 kg
Bruciatore / burner / brûleur / quemador	1,8 lt
Potenza / power / puissance / potencia	2,5 kw
Garanzia / warranty / garantie / garantía	2 anni + 1 anno / year Ethaline*

\* Ethaline ti allunga la garanzia di 12 mesi

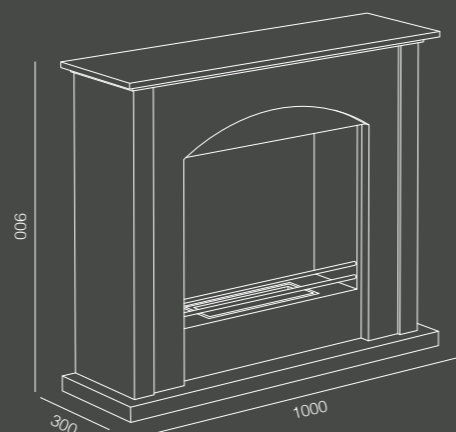

# Udine

Biocamino da pavimento. Struttura in legno verniciato bianco. Bruciatore removibile e regolabile con fibra.

Free-standing bioethanol fireplace white painted wooden structure. Adjustable and removable burner with fiber.

Bio-cheminée de sol. Structure en bois peint en blanc. Brûleur amovible et réglable avec fibre.

Bio-chimenea de suelo. Estructura de madera pintada de blanco. Quemador extraíble y ajustable con fibra.



Dimensioni / dim. (H x L x P)	880 x 1000 x 300 mm
Peso Netto / net weight / poids / peso	31 kg
Bruciatore / burner / brûleur / quemador	1,8 lt
Potenza / power / puissance / potencia	2,5 kw
Garanzia / warranty / garantie / garantía	2 anni + 1 anno / year Ethaline*

\* Ethaline ti allunga la garanzia di 12 mesi

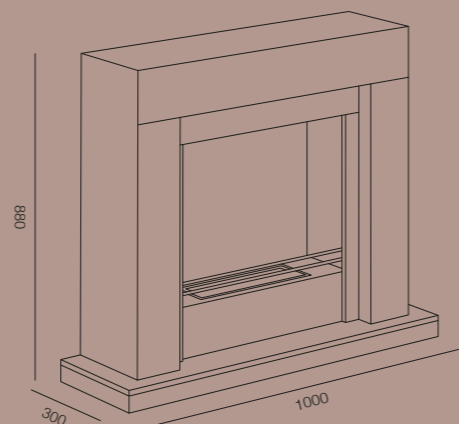



# Dubai

Biocamino da pavimento. Struttura in acciaio verniciato e vetro di protezione. Bruciatore removibile e regolabile con fibra.

Free-standing bioethanol fireplace. Stainless steel structure and protective glass. Adjustable and removable burner with fiber.

Bio-cheminée de sol. Structure en acier peint avec vitre de protection. Brûleur desmontable y réglable en fibres.

Bio-chimenea de suelo. Estructura de acero pintado y cristal protector. Quemador amovible et regulable con fibra.



Vedi in Realtà Aumentata  
See in Augmented Reality  
Ver en Realidad Aumentada  
Voir en réalité augmentée



Dimensioni / dim. (H x Ø)	950 x 500 mm
Peso Netto / net weight / poids / peso	22,5 kg
Bruciatore / burner / brûleur / quemador	2,0 lt
Potenza / power / puissance / potencia	2,5 kw
Garanzia / warranty / garantie / garantía	2 anni + 1 anno / year Ethaline*

\* Ethaline ti allunga la garanzia di 12 mesi

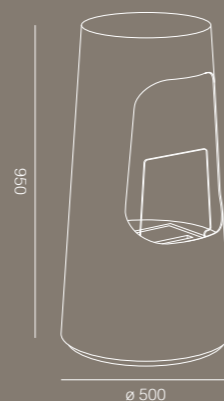

# Dubai

Biocamino da pavimento. Struttura in acciaio verniciato e vetro di protezione. Bruciatore removibile e regolabile con fibra.

Free-standing bioethanol fireplace. Stainless steel structure and protective glass. Adjustable and removable burner with fiber.

Bio-cheminée de sol. Structure en acier peint avec vitre de protection. Brûleur desmontable y réglable en fibres.

Bio-chimenea de suelo. Estructura de acero pintado y cristal protector. Quemador amovible et regulable con fibra.



Vedi in Realtà Aumentata  
See in Augmented Reality  
Ver en Realidad Aumentada  
Voir en réalité augmentée



Dimensioni / dim. (H x Ø)	950 x 500 mm
Peso Netto / net weight / poids / peso	22,5 kg
Bruciatore / burner / brûleur / quemador	2,0 lt
Potenza / power / puissance / potencia	2,5 kw
Garanzia / warranty / garantie / garantía	2 anni + 1 anno / year Ethaline*

\* Ethaline ti allunga la garanzia di 12 mesi

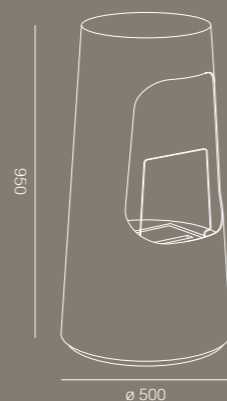

# Falcade

Biocamino da pavimento. Struttura in legno verniciato bianco. Bruciatore removibile e regolabile con fibra. Dimensioni compatte.

Free-standing bioethanol fireplace white painted wooden structure. Adjustable and removable burner with fiber. Compact dimensions.

Bio-cheminée de sol. Structure en bois peint en blanc. Brûleur amovible et réglable avec fibre. Dimensions compactes.

Bio-chimenea de suelo. Estructura de madera pintada de blanco. Quemador extraíble y ajustable con fibra. Dimensiones compactas.



Dimensioni / dim. (H x L x P)	690 x 700 x 300 mm
Peso Netto / net weight / poids / peso	22,5 kg
Bruciatore / burner / brûleur / quemador	1,0 lt
Potenza / power / puissance / potencia	2,0 kw
Garanzia / warranty / garantie / garantía	2 anni + 1 anno / year Ethaline*

\* Ethaline ti allunga la garanzia di 12 mesi

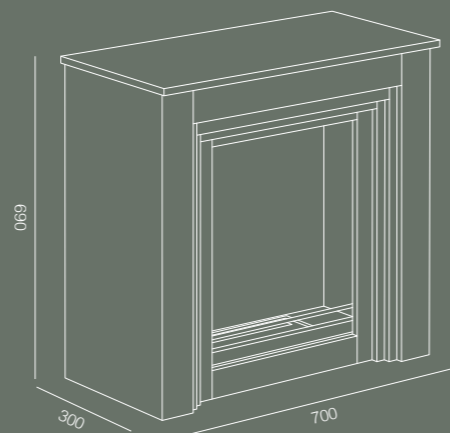

# Matera

Biocamino da pavimento. Struttura in legno verniciato bianco. Bruciatore removibile e regolabile con fibra. Dimensioni compatte.

Free-standing bioethanol fireplace white painted wooden structure. Adjustable and removable burner with fiber. Compact dimensions.

Bio-cheminée de sol. Structure en bois peint en blanc. Brûleur amovible et réglable avec fibre. Dimensions compactes

Bio-chimenea de suelo. Estructura de madera pintada de blanco Quemador extraíble y ajustable con fibra. Dimensiones compactas



Dimensioni / dim. (H x L x P)	710 x 700 x 300 mm
Peso Netto / net weight / poids / peso	22,5 kg
Bruciatore / burner / brûleur / quemador	1,0 lt
Potenza / power / puissance / potencia	2,0 kw
Garanzia / warranty / garantie / garantía	2 anni + 1 anno / year Ethaline*

\* Ethaline ti allunga la garanzia di 12 mesi

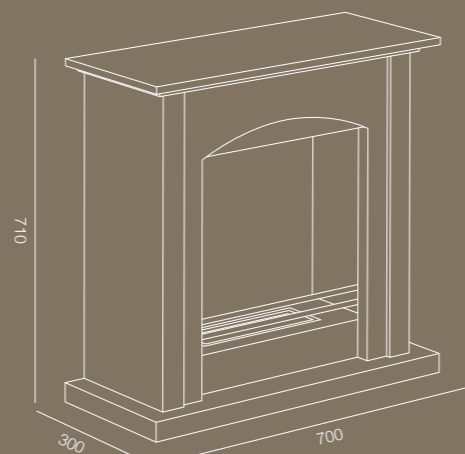

# Camogli

Biocamino da pavimento. Struttura in legno verniciato bianco. Bruciatore removibile e regolabile con fibra. Dimensioni compatte.

Free-standing bioethanol fireplace white painted wooden structure. Adjustable and removable burner with fiber. Compact dimensions.

Bio-cheminée de sol. Structure en bois peint en blanc. Brûleur amovible et réglable avec fibre. Dimensions compactes.

Bio-chimenea de suelo. Estructura de madera pintada de blanco. Quemador extraíble y ajustable con fibra. Dimensiones compactas.



Dimensioni / dim. (H x L x P)	690 x 700 x 300 mm
Peso Netto / net weight / poids / peso	20 Kg
Bruciatore / burner / brûleur / quemador	1,0 lt
Potenza / power / puissance / potencia	2,0 kw
Garanzia / warranty / garantie / garantía	2 anni + 1 anno / year Ethaline*

\* Ethaline ti allunga la garanzia di 12 mesi

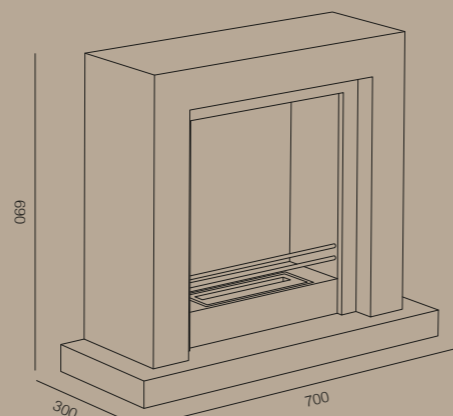

# Nairobi

Biocamino da pavimento. Struttura in acciaio verniciato e vetro. Bruciatore removibile con fibra e coperchio di chiusura fiamma.

Free-standing bioethanol fireplace. Painted stainless steel and glass structure. Burner removable with fiber and flame closing cover.

Cheminée au sol. Structure en acier peint et verre. Brûleur amovible cylindrique avec fibre et tige stop brûleur.

Chimenea de suelo. Estructura en acero pintado y vidrio. Quemador desmontable con fibra y tapa de cierre de llama.



Dimensioni / dim. (H x L x P)	1200 x 345 x 345 mm
Peso Netto / net weight / poids / peso	14 kg
Bruciatore / burner / brûleur / quemador	1,2 lt
Potenza / power / puissance / potencia	1,5 kw
Garanzia / warranty / garantie / garantía	2 anni + 1 anno / year Ethaline*

\* Ethaline ti allunga la garanzia di 12 mesi

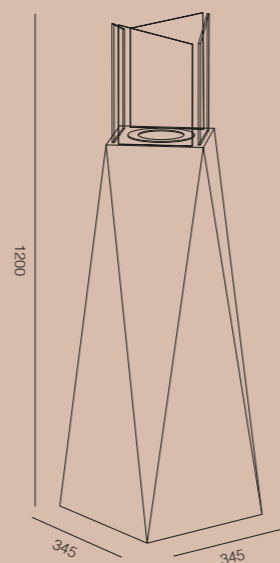

# Roma

Biocamino da pavimento. Struttura in acciaio verniciato e vetro. Bruciatore removibile e regolabile con fibra.

Free-standing bioethanol fireplace. Painted stainless steel and glass structure. Adjustable and removable burner with fiber.

Cheminée au sol. Structure en acier peint et verre. Brûleur démontable y réglable avec fibre.

Chimenea de suelo. Estructura en acero pintado y vidrio. Quemador amovible et regulable con fibra.



Dimensioni / dim. (H x L x P)	625 x 1000 x 300 mm
Peso Netto / net weight / poids / peso	25 kg
Bruciatore / burner / brûleur / quemador	1,5 lt
Potenza / power / puissance / potencia	2,5 kw
Garanzia / warranty / garantie / garantía	2 anni + 1 anno / year Ethaline*

\* Ethaline ti allunga la garanzia di 12 mesi

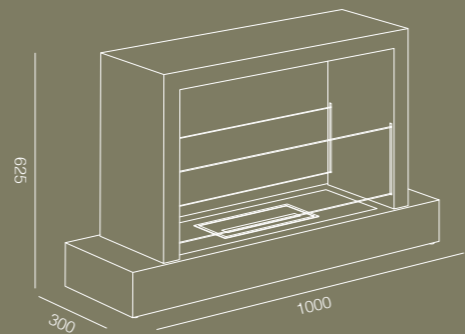

# Cortina

Biocamino da pavimento. Struttura in acciaio verniciato e vetro. Bruciatore removibile e regolabile con fibra.

Free-standing bioethanol fireplace. Painted stainless steel and glass structure. Adjustable and removable burner with fiber.

Cheminée au sol. Structure en acier peint et verre. Brûleur démontable y réglable avec fibre.

Chimenea de suelo. Estructura en acero pintado y vidrio. Quemador amovible et regulable con fibra.



Dimensioni / dim. (H x L x P)	950 x ø 480 mm
Peso Netto / net weight / poids / peso	23 kg
Bruciatore / burner / brûleur / quemador	1,2 lt
Potenza / power / puissance / potencia	2,5 kw
Garanzia / warranty / garantie / garantía	2 anni + 1 anno / year Ethaline*

\* Ethaline ti allunga la garanzia di 12 mesi

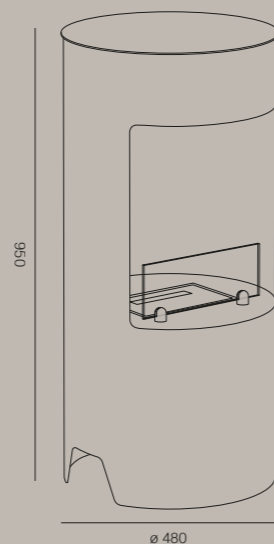



# Cortina

Biocamino da pavimento. Struttura in acciaio verniciato e vetro. Bruciatore removibile e regolabile con fibra.

Free-standing bioethanol fireplace. Painted stainless steel and glass structure. Adjustable and removable burner with fiber.

Cheminée au sol. Structure en acier peint et verre. Brûleur démontable y réglable avec fibre.

Chimenea de suelo. Estructura en acero pintado y vidrio. Quemador amovible et regulable con fibra.



Dimensioni / dim. (H x L x P)	950 x ø 480 mm
Peso Netto / net weight / poids / peso	23 kg
Bruciatore / burner / brûleur / quemador	1,2 lt
Potenza / power / puissance / potencia	2,5 kw
Garanzia / warranty / garantie / garantía	2 anni + 1 anno / year Ethaline*

\* Ethaline ti allunga la garanzia di 12 mesi

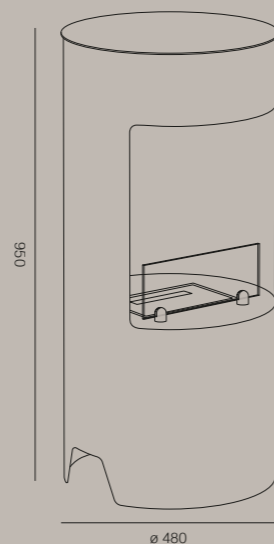

# Bologna

Biocamino da Pavimento. Struttura in acciaio verniciato e vetro. Bruciatore removibile e regolabile con fibra.

Free-standing bioethanol fireplace. Painted stainless steel and glass structure. Adjustable and removable burner with fiber.

Cheminée au sol. Structure en acier peint et verre. Brûleur démontable y réglable avec fibre.

Chimenea de suelo. Estructura en acero pintado y vidrio. Quemador amovible et regulable con fibra.



Dimensioni / dim. (H x L x P)	520 x 640 x 230 mm
Peso Netto / net weight / poids / peso	12 kg
Bruciatore / burner / brûleur / quemador	1,5 lt
Potenza / power / puissance / potencia	2,0 kw
Garanzia / warranty / garantie / garantía	2 anni + 1 anno / year Ethaline*

\* Ethaline ti allunga la garanzia di 12 mesi

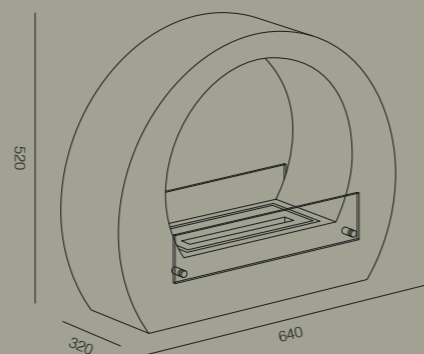

# Trento

Biocamino da Pavimento. Struttura in acciaio verniciato e vetro. Bruciatore removibile e regolabile con fibra.

Free-standing bioethanol fireplace. Painted stainless steel and glass structure. Adjustable and removable burner with fiber.

Cheminée au sol. Structure en acier peint et verre. Brûleur démontable y réglable avec fibre.

Chimenea de suelo. Estructura en acero pintado y vidrio. Quemador amovible et regulable con fibra.



Dimensioni / dim. (H x L x P)	455 x 755 x 300 mm
Peso Netto / net weight / poids / peso	10 kg
Bruciatore / burner / brûleur / quemador	1,5 lt
Potenza / power / puissance / potencia	2,0 kw
Garanzia / warranty / garantie / garantía	2 anni + 1 anno / year Ethaline*

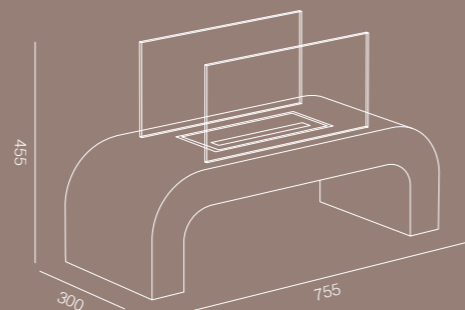

\* Ethaline ti allunga la garanzia di 12 mesi



# Elysium

Biocamino da parete. Struttura in acciaio verniciato e vetro. Bruciatore removibile e regolabile con fibra.

Wall bioethanol fireplace. Painted stainless steel and glass structure. Adjustable and removable burner with fiber.

Cheminée murale. Structure en acier peint et verre. Brûleur démontable y réglable avec fibre.

Chimenea mural. Estructura en acero pintado y vidrio. Quemador amovible et regulable con fibra.



Vedi in Realtà Aumentata  
See in Augmented Reality  
Ver en Realidad Aumentada  
Voir en réalité augmentée



Dimensioni / dim. (H x L x P)	880 x 880 x 210 mm
Peso Netto / net weight / poids / peso	26 kg
Bruciatore / burner / brûleur / quemador	1,3 lt
Potenza / power / puissance / potencia	2,5 kw
Garanzia / warranty / garantie / garantía	2 anni + 1 anno / year Ethaline*

\* Ethaline ti allunga la garanzia di 12 mesi

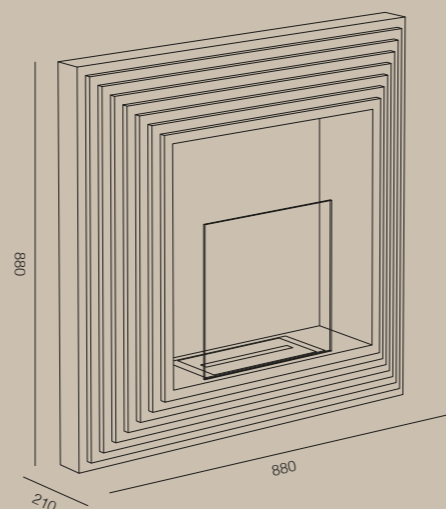

# Verona

Biocamino a parete o incasso. Struttura in acciaio e vetro. Bruciatore removibile e regolabile con fibra. Sistema di installazione a parete con possibilità di incasso.

Wall or built-in bioethanol fireplace. Painted stainless steel and glass structure. Adjustable and removable burner with fiber. Wall installation system with built-in possibility.

Bio-cheminée murale ou encastrable. Structure en acier peint et verre. Brûleur démontable y réglable avec fibre. Système d'installation murale avec possibilité d'encastrement.

Biochimenea de pared o empotrada. Estructura en acero pintado y vidrio. Quemador amovible et regulable con fibra. Sistema de instalación en pared con posibilidad de empotrar.

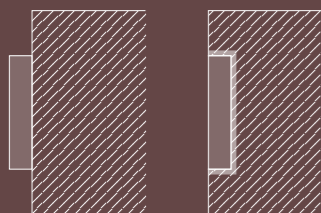

Dimensioni foro per incasso  
L.825 x P.135 x H.426 mm



Conforme alla normativa EN 16647:2016

Dimensioni / dim. (H x L x P)	450 x 850 x 180 mm
Peso Netto / net weight / poids / peso	19,5 kg
Bruciatore / burner / brûleur / quemador	2,9 lt
Potenza / power / puissance / potencia	3,0 kw
Garanzia / warranty / garantie / garantía	2 anni + 1 anno / year Ethaline*

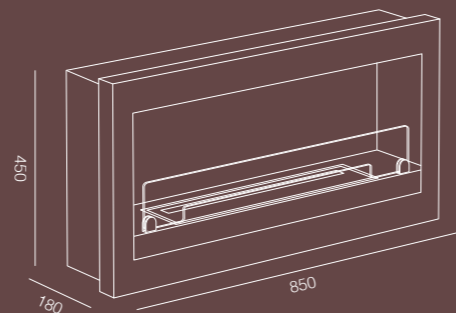

\* Ethaline ti allunga la garanzia di 12 mesi



# Verona

Biocamino a parete o incasso. Struttura in acciaio verniciato e vetro. Bruciatore removibile e regolabile con fibra. Sistema di installazione a parete con possibilità di incasso.

Wall or built-in bioethanol fireplace. Painted stainless steel and glass structure. Adjustable and removable burner with fiber. Wall installation system with built-in possibility.

Bio-cheminée murale ou encastrable. Structure en acier peint et verre. Brûleur démontable et réglable avec fibre. Système d'installation murale avec possibilité d'encastrement.

Biochimenea de pared o empotrada. Estructura en acero pintado y vidrio. Quemador amovible et regulable con fibra. Sistema de instalación en pared con posibilidad de empotrar.

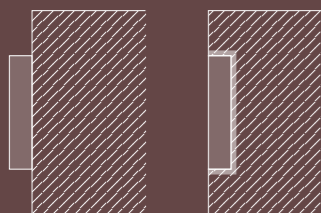

Dimensioni foro per incasso  
L.825 x P.135 x H.426 mm



Conforme alla normativa EN 16647:2016

Dimensioni / dim. (H x L x P)	450 x 850 x 180 mm
Peso Netto / net weight / poids / peso	19,5 kg
Bruciatore / burner / brûleur / quemador	2,9 lt
Potenza / power / puissance / potencia	3,0 kw
Garanzia / warranty / garantie / garantía	2 anni + 1 anno / year Ethaline*

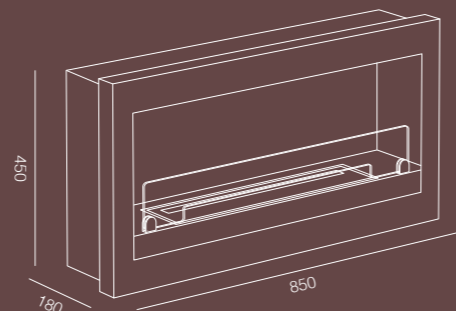

\* Ethaline ti allunga la garanzia di 12 mesi



# Verona

Biocamino a parete o incasso. Struttura in acciaio verniciato e vetro. Bruciatore removibile e regolabile con fibra. Sistema di installazione a parete con possibilità di incasso.

Wall or built-in bioethanol fireplace. Painted stainless steel and glass structure. Adjustable and removable burner with fiber. Wall installation system with built-in possibility.

Bio-cheminée murale ou encastrable. Structure en acier peint et verre. Brûleur desmontable y réglable avec fibre. Système d'installation murale avec possibilité d'encastrement.

Biochimenea de pared o empotrada. Estructura en acero pintado y vidrio. Quemador amovible et regulable con fibra. Sistema de instalación en pared con posibilidad de empotrar.

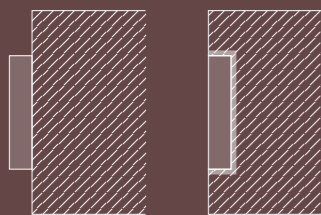

Dimensioni foro per incasso  
L.825 x P.135 x H.426 mm



Conforme alla normativa EN 16647:2016

Dimensioni / dim. (H x L x P)	450 x 850 x 180 mm
Peso Netto / net weight / poids / peso	19,5 kg
Bruciatore / burner / brûleur / quemador	2,9 lt
Potenza / power / puissance / potencia	3,0 kw
Garanzia / warranty / garantie / garantía	2 anni + 1 anno / year Ethaline*

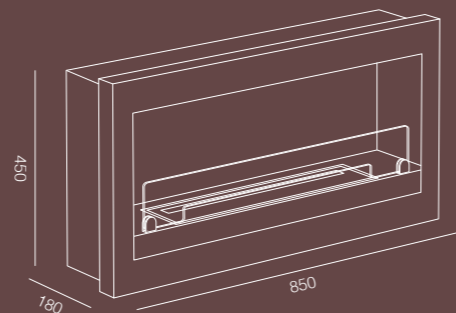

\* Ethaline ti allunga la garanzia di 12 mesi



# Treviso

Biocamino a parete o incasso. Struttura in acciaio e vetro. Bruciatore removibile e regolabile con fibra. Sistema di installazione a parete con possibilità di incasso.

Wall or built-in bioethanol fireplace. Painted stainless steel and glass structure. Adjustable and removable burner with fiber. Wall installation system with built-in possibility.

Bio-cheminée murale ou encastrable. Structure en acier peint et verre. Brûleur démontable et réglable avec fibre. Système d'installation murale avec possibilité d'encastrement.

Biochimenea de pared o empotrada. Estructura en acero pintado y vidrio. Quemador amovible et regulable con fibra. Sistema de instalación en pared con posibilidad de empotrar.

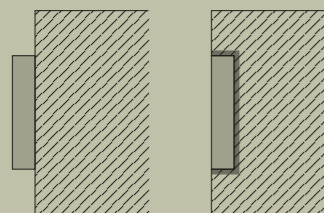

Dimensioni foro per incasso  
L.625 x P.135 x H.426 mm



Dimensioni / dim. (H x L x P)	450 x 650 x 180 mm
Peso Netto / net weight / poids / peso	15 kg
Bruciatore / burner / brûleur / quemador	1,9 lt
Potenza / power / puissance / potencia	2,5 kw
Garanzia / warranty / garantie / garantía	2 anni + 1 anno / year Ethaline*

\* Ethaline ti allunga la garanzia di 12 mesi

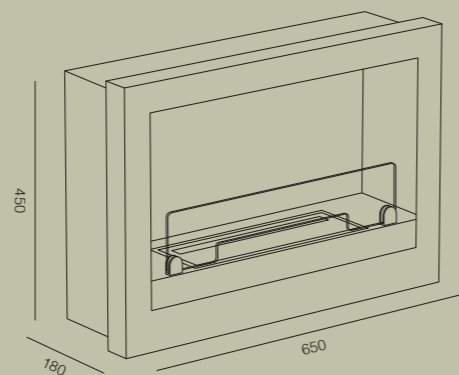



# Treviso

Biocamino a parete o incasso. Struttura in acciaio verniciato e vetro. Bruciatore removibile e regolabile con fibra. Sistema di installazione a parete con possibilità di incasso.

Wall or built-in bioethanol fireplace. Painted stainless steel and glass structure. Adjustable and removable burner with fiber. Wall installation system with built-in possibility.

Bio-cheminée murale ou encastrable. Structure en acier peint et verre. Brûleur démontable et réglable avec fibre. Système d'installation murale avec possibilité d'encastrement.

Biochimenea de pared o empotrada. Estructura en acero pintado y vidrio. Quemador amovible et regulable con fibra. Sistema de instalación en pared con posibilidad de empotrar.

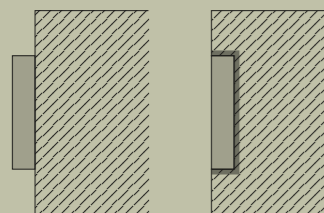

Dimensioni foro per incasso  
L.625 x P.135 x H.426 mm



Dimensioni / dim. (H x L x P)	450 x 650 x 180 mm
Peso Netto / net weight / poids / peso	15 kg
Bruciatore / burner / brûleur / quemador	1,9 lt
Potenza / power / puissance / potencia	2,5 kw
Garanzia / warranty / garantie / garantía	2 anni + 1 anno / year Ethaline*

\* Ethaline ti allunga la garanzia di 12 mesi

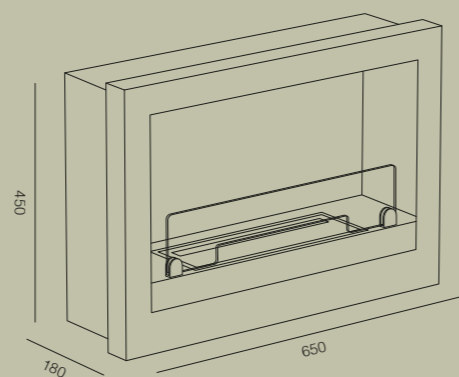

# Treviso

Biocamino a parete o incasso. Struttura in acciaio verniciato e vetro. Bruciatore removibile e regolabile con fibra. Sistema di installazione a parete con possibilità di incasso.

Wall or built-in bioethanol fireplace. Painted stainless steel and glass structure. Adjustable and removable burner with fiber. Wall installation system with built-in possibility.

Bio-cheminée murale ou encastrable. Structure en acier peint et verre. Brûleur démontable y réglable avec fibre. Système d'installation murale avec possibilité d'encastrement.

Biochimenea de pared o empotrada. Estructura en acero pintado y vidrio. Quemador amovible et regulable con fibra. Sistema de instalación en pared con posibilidad de empotrar.

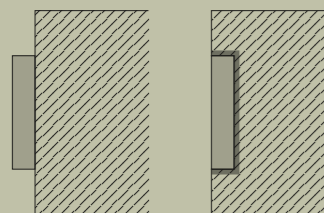

Dimensioni foro per incasso  
L.625 x P.135 x H.426 mm



Dimensioni / dim. (H x L x P)	450 x 650 x 180 mm
Peso Netto / net weight / poids / peso	15 kg
Bruciatore / burner / brûleur / quemador	1,9 lt
Potenza / power / puissance / potencia	2,5 kw
Garanzia / warranty / garantie / garantía	2 anni + 1 anno / year Ethaline*

\* Ethaline ti allunga la garanzia di 12 mesi

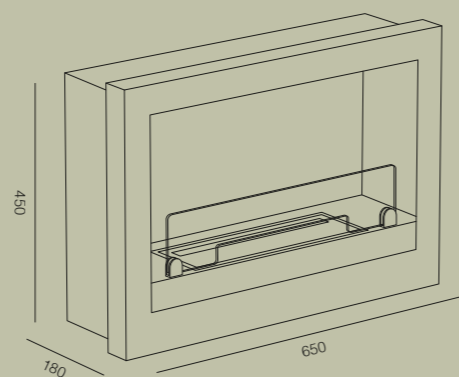

# Palmanova

Biocamino a parete. Struttura in acciaio verniciato e vetro. Bruciatore removibile e regolabile con fibra.

Wall bioethanol fireplace. Painted stainless steel and glass structure. Adjustable and removable burner with fiber.

Cheminée murale. Structure en acier peint et verre. Brûleur démontable y réglable avec fibre.

Chimenea mural. Estructura en acero pintado y vidrio. Quemador amovible et regulable con fibra.



Dimensioni / dim. (H x L x P)	648 x 648 x 154 mm
Peso Netto / net weight / poids / peso	13 kg
Bruciatore / burner / brûleur / quemador	1,0 lt
Potenza / power / puissance / potencia	1,5 kw
Garanzia / warranty / garantie / garantía	2 anni + 1 anno / year Ethaline*

\* Ethaline ti allunga la garanzia di 12 mesi

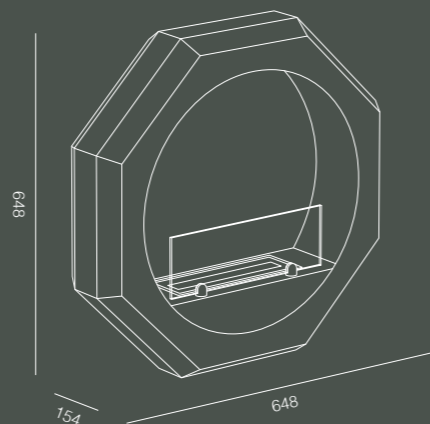

# Altea

Biocamino da tavolo o a parete. Struttura in acciaio verniciato e vetro. Bruciatore removibile con fibra e coperchio di chiusura fiamma. Possibilità di installazione anche a parete

Wall or table bioethanol fireplace. Painted stainless steel and glass structure. Burner removable with fiber and flame closing cover. Possibility of wall installation too.

Bio-cheminée murale ou de table. Structure en acier peint et verre. Brûleur amovible cylindrique avec fibre et tige stop brûleur. Possibilité d'installation murale aussi.

Biochimenea de pared o de sobremesa. Estructura en acero pintado y vidrio. Quemador amovible et regulable con fibra y tapa de cierre de llama. Posibilidad de instalación en pared también.



Dimensioni / dim. (H x L x P)	400 x 240 x 210 mm
Peso Netto / net weight / poids / peso	6,4 kg
Bruciatore / burner / brûleur / quemador	0,35 lt
Potenza / power / puissance / potencia	0,8 kw
Garanzia / warranty / garantie / garantía	2 anni + 1 anno / year Ethaline*

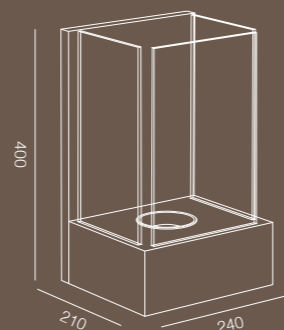

\* Ethaline ti allunga la garanzia di 12 mesi



# Giga

Product Launch

Biocamino da pavimento. Struttura in acciaio verniciato e porta con vetro di protezione. Bruciatore removibile e regolabile con fibra.

Free-standing bioethanol fireplace. Stainless steel structure and door with protective glass. Adjustable and removable burner with fiber.

Bio-cheminée de sol. Structure en acier peint et porte avec vitre de protection. Brûleur démontable et réglable en fibre.

Bio-chimenea de suelo. Estructura de acero pintado y puerta con cristal protector. Quemador amovible et regulable con fibra.



Dimensioni / dim. (H x L x P)	905 x 470 x 260 mm
Peso Netto / net weight / poids / peso	25,9 kg
Bruciatore / burner / brûleur / quemador	1,2 lt
Potenza / power / puissance / potencia	3,0 kw
Garanzia / warranty / garantie / garantía	2 anni + 1 anno / year Ethaline*

\* Ethaline ti allunga la garanzia di 12 mesi

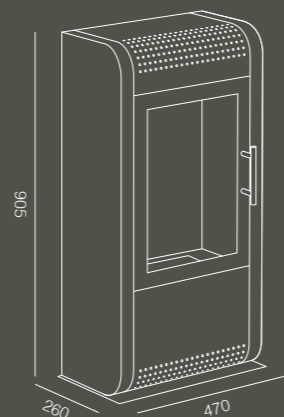

# Delta

Product Launch

Biocamino da pavimento. Struttura in acciaio verniciato e porta con vetro di protezione. Bruciatore removibile e regolabile con fibra.

Free-standing bioethanol fireplace. Stainless steel structure and door with protective glass. Adjustable and removable burner with fiber.

Bio-cheminée de sol. Structure en acier peint et porte avec vitre de protection. Brûleur démontable et réglable en fibre.

Bio-chimenea de suelo. Estructura de acero pintado y puerta con cristal protector. Quemador amovible et regulable con fibra.



Dimensioni / dim. (H x L x P)	653 x 454 x 377 mm
Peso Netto / net weight / poids / peso	19,9 kg
Bruciatore / burner / brûleur / quemador	1,50 lt
Potenza / power / puissance / potencia	2,5 kw
Garanzia / warranty / garantie / garantía	2 anni + 1 anno / year Ethaline*

\* Ethaline ti allunga la garanzia di 12 mesi

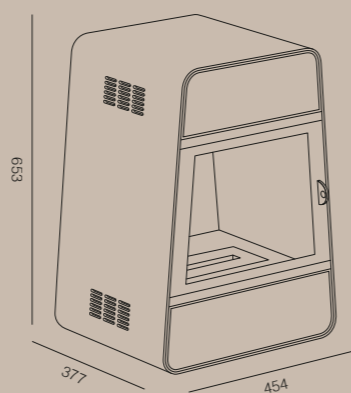

# Delta

Product Launch

Biocamino da pavimento. Struttura in acciaio verniciato e porta con vetro di protezione. Bruciatore removibile e regolabile con fibra.

Free-standing bioethanol fireplace. Stainless steel structure and door with protective glass. Adjustable and removable burner with fiber.

Bio-cheminée de sol. Structure en acier peint et porte avec vitre de protection. Brûleur démontable y réglable en fibre.

Bio-chimenea de suelo. Estructura de acero pintado y puerta con cristal protector. Quemador amovible et regulable con fibra.



Dimensioni / dim. (H x L x P)	653 x 454 x 377 mm
Peso Netto / net weight / poids / peso	19,9 kg
Bruciatore / burner / brûleur / quemador	1,50 lt
Potenza / power / puissance / potencia	2,5 kw
Garanzia / warranty / garantie / garantía	2 anni + 1 anno / year Ethaline*

\* Ethaline ti allunga la garanzia di 12 mesi

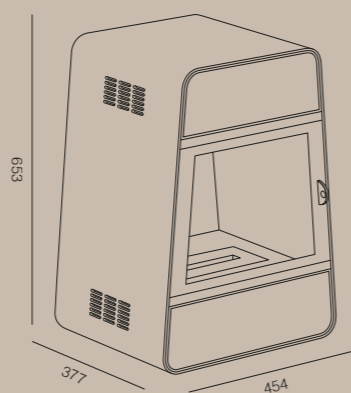

# Delta

Product Launch

Biocamino da pavimento. Struttura in acciaio verniciato e porta con vetro di protezione. Bruciatore removibile e regolabile con fibra.

Free-standing bioethanol fireplace. Stainless steel structure and door with protective glass. Adjustable and removable burner with fiber.

Bio-cheminée de sol. Structure en acier peint et porte avec vitre de protection. Brûleur démontable et réglable en fibre.

Bio-chimenea de suelo. Estructura de acero pintado y puerta con cristal protector. Quemador amovible et regulable con fibra.



Dimensioni / dim. (H x L x P)	653 x 454 x 377 mm
Peso Netto / net weight / poids / peso	19,9 kg
Bruciatore / burner / brûleur / quemador	1,50 lt
Potenza / power / puissance / potencia	2,5 kw
Garanzia / warranty / garantie / garantía	2 anni + 1 anno / year Ethaline*

\* Ethaline ti allunga la garanzia di 12 mesi

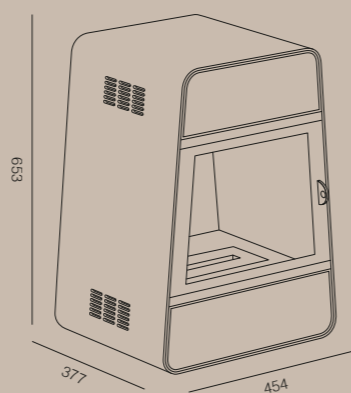



# Rialto Wall Product Launch

Biocamino a parete. Struttura in acciaio verniciato e vetro. Bruciatore removibile con fibra e coperchio di chiusura fiamma.

Wall bioethanol fireplace. Painted stainless steel and glass structure. Burner removable with fiber and flame closing cover.

Cheminée murale. Structure en acier peint et verre. Brûleur amovible cylindrique avec fibre et tige stop brûleur.

Chimenea mural. Estructura en acero pintado y vidrio. Quemador amovible et regulable con fibra y tapa de cierre de llama.



Dimensioni / dim. (H x L x P)	740 x 860 x 420 mm
Peso Netto / net weight / poids / peso	13 kg
Bruciatore / burner / brûleur / quemador	2,2 lt
Potenza / power / puissance / potencia	2,0 kw
Garanzia / warranty / garantie / garantía	2 anni + 1 anno / year Ethaline*

\* Ethaline ti allunga la garanzia di 12 mesi

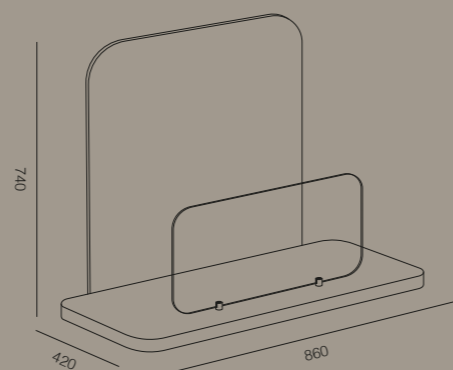

# OpenClosed

Product Launch

Biocamino da tavolo. Struttura in acciaio verniciato bruciatore removibile con fibra e coperchio di chiusura fiamma. Con innovativo sistema di apertura e chiusura a scorrimento.

Table bioethanol fireplace. Painted stainless steel structure. Burner removable with fiber and flame closing cover. With innovative sliding opening and closing system

Cheminée de table. Structure en acier peint. Brûleur amovible cylindrique avec fibre et tige stop brûleur. Avec système d'ouverture et de fermeture coulissant innovant

Chimenea de sobremesa. Estructura en acero pintado. Quemador desmontable con fibra y tapa de cierre de llama. Con innovador sistema de apertura y cierre deslizante.



Dimensioni / dim. (H x L x P)	81 x 570 x 285 C – 405 O mm
Peso Netto / net weight / poids / peso	5,0 kg
Bruciatore / burner / brûleur / quemador	0,90 lt
Potenza / power / puissance / potencia	1,2 kw
Garanzia / warranty / garantie / garantía	2 anni + 1 anno / year Ethaline*

\* Ethaline ti allunga la garanzia di 12 mesi

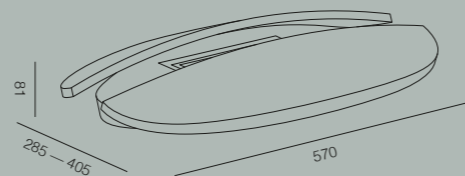

# OpenClosed

Product Launch

Biocamino da tavolo. Struttura in acciaio verniciato bruciatore removibile con fibra e coperchio di chiusura fiamma. Con innovativo sistema di apertura e chiusura a scorrimento.

Table bioethanol fireplace. Painted stainless steel structure. Burner removable with fiber and flame closing cover. With innovative sliding opening and closing system

Cheminée de table. Structure en acier peint. Brûleur amovible cylindrique avec fibre et tige stop brûleur. Avec système d'ouverture et de fermeture coulissant innovant

Chimenea de sobremesa. Estructura en acero pintado. Quemador desmontable con fibra y tapa de cierre de llama. Con innovador sistema de apertura y cierre deslizante.



Dimensioni / dim. (H x L x P)	81 x 570 x 285 C – 405 O mm
Peso Netto / net weight / poids / peso	5,0 kg
Bruciatore / burner / brûleur / quemador	0,90 lt
Potenza / power / puissance / potencia	1,2 kw
Garanzia / warranty / garantie / garantía	2 anni + 1 anno / year Ethaline*

\* Ethaline ti allunga la garanzia di 12 mesi

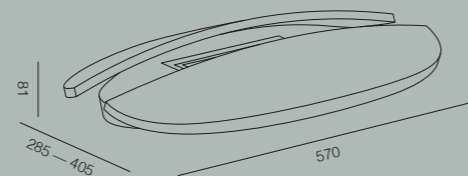

# GARANTIAMO ASSOLUTA QUALITÀ / THE PROOF OF EXCELLENT QUALITY



Per Tecno Air System la qualità non è solo una parola, ma si traduce in garanzia sui prodotti commercializzati, sull'assistenza e sul supporto al cliente. I prodotti Tecno Air System sono sicuri, vengono testati e la loro funzionalità è garantita negli anni. Prodotti di qualità per l'uso dei materiali di produzione, per il sistema con cui sono progettati che li rende pratici nell'uso, affidabili e sicuri. La ricerca tecnologica continua permette a Tecno Air System di offrire modelli sempre nuovi, al passo con le tendenze di mercato. Tecno Air System è da sempre al fianco dei suoi partner, a cui offre un servizio dedicato di assistenza che permette di risolvere in ogni momento qualsiasi tipo di problematica.

For Tecno Air System the meaning of quality is not just a word but it is the result of the best features products and high customer care. Tecno Air System products are safety and also tested according the most updated standards. The technical features have been guaranteed for over the years. The products are high quality because of the use of good materials construction and excellent planning design make them easy to use and safe. The study process in progress allows Tecno Air System to offer always new models according to the latest market trends. Tecno Air System has always been at the side of its partners, offering a dedicated assistance service that resolves any type of problems at any time.

L'azienda e i prodotti Tecno Air System vantano le certificazioni che garantiscono sistemi produttivi dagli standard elevati e prodotti conformi alle normative in vigore / Tecno Air System company and products are in compliance with certifications that guarantee process management system and technical features product in according to the latest standards.



**ISO 9001:2015.** La garanzia che l'azienda si impegna a mantenere la massima efficienza e trasparenza del processo produttivo, controllando attentamente, la progettazione, la produzione, la distribuzione, i fornitori e l'organizzazione al proprio interno / The proof that the production, design and sales process has properly checked in according the standard.



**EN 16647:2016.** Certificazione che attesta la conformità alla normativa applicata ai Biocamini e alle Biostufe in materia di sicurezza, qualità dei materiali e standard produttivi / Certification according the European standard contains the technical features of the fireplaces.



**TecnoAir** | idee  
**System** | per vivere  
meglio

Via Piovega, 10  
31017 Pieve Del Grappa (TV)  
T + 39 0423 948800  
F +39 0423 948821  
[www.tecnoairsystem.it](http://www.tecnoairsystem.it)

Azienda con sistema di  
gestione per la qualità certificata  
ISO 9001:2015  
da TÜV Rheinland