

Ref. PF4

UP



USERS



+12 years



16,8 m²



Measurements expressed in millimeters

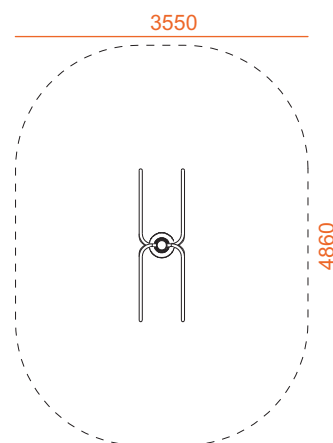
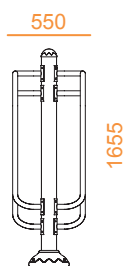
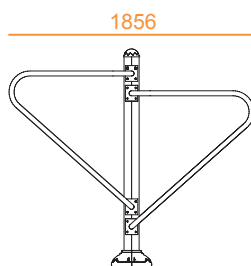

FEATURES

BENEFITS: Exercises the muscles of the upper limbs, chest, abdomen and back.

MANUFACTURING: Tube structure made of galvanized steel with reinforced tread system and polypropylene handles.

FINISHING: Baked polyester paint, black and grey RAL9006 colour.

INSTALLATION: Available for installation on hard ground and soft ground.

TECHNIQUE: Get on the equipment, resting your arms on the bars, and do push-ups.

Veillez à ce que les coudes soient le plus près possible du buste.