



Ref. PF7

SKATE



USERS



+12 years



14m²



Measurements expressed in millimeters

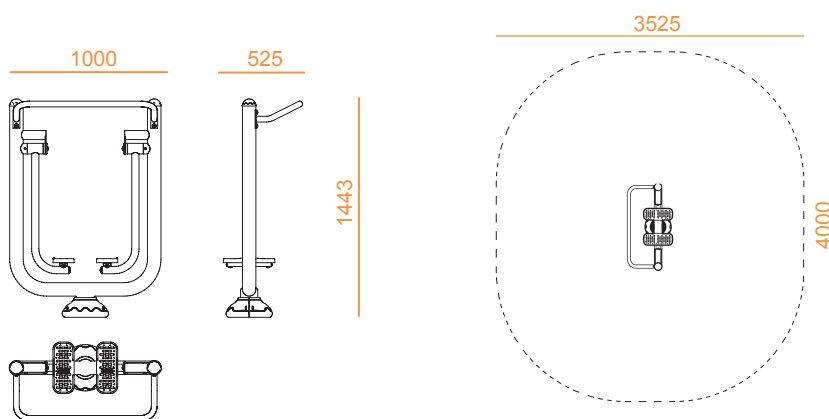

FEATURES

- BENEFITS:** Exercises and improves the muscles of the lower limbs and buttocks, increases cardiac output.
- MANUFACTURING:** Tube structure made of galvanized steel with reinforced tread system and polypropylene handles.
- FINISHING:** Baked polyester paint, black and grey RAL9006 colour.
- INSTALLATION:** Available for installation on hard ground and soft ground.
- TECHNIQUE:** Using the handles position yourself on the steps, making sure your body is at its centre of gravity.
Without forcing, swing your legs back and forth, keeping your back straight at all times.
To avoid accidents grip the handle hard and do not get off the equipment until both pedals are parallel and stationary.