



Ref. PF20

SPIN



USERS



+12 years



Measurements expressed in millimeters

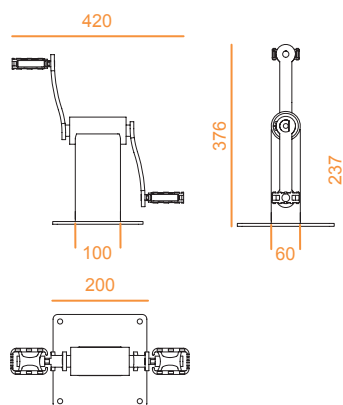

FEATURES

- BENEFITS:** Exercise the muscles of the legs and hips. Improved flexibility, stability and coordination of the lower limbs.
- MANUFACTURING:** Tube structure made of galvanized steel with reinforced tread system and self-lubricating bearings with an exclusive braking system.
- FINISHING:** Baked polyester paint.
- INSTALLATION:** Available for installation on hard ground and soft ground.