

Smappee EV One HOME

Installation manual



Document Accuracy

The specifications and other information in this document were verified to be accurate and complete at the time of its publication. Due to ongoing product improvement, this information is subject to change at any time without prior notice. For the latest information, see our online documentation: <https://www.smappee.com/downloads>

Table of contents

1. Introduction	4
2. Safety instructions.....	5
3. Models	7
4. Components.....	8
5. Technical specifications.....	10
6. Preparing the installation	13
7. Installation and activation	16
8. Using the EV One Home.....	30
Declaration of conformity	34

1. Introduction

Thank you for purchasing this Smappee EV One Home charging station for electric vehicles, the smartest charging station for charging at home.

This installation and user manual tells you how to install and use the Smappee EV One Home. We advise you to read the contents of this manual carefully, to ensure a safe and proper installation and enable you to use all the advanced features of this product to their full extent.

Support

Only qualified electricians or equivalent may install the Smappee EV One Home. If you have any questions, please contact your service partner.

Please have the following information ready to hand to speed up the process: Article number and serial number which you can find on the identification label of the charging station.



Should your local distributor be unable to help you, or you have a suggestion for us, you can contact Smappee at: **support@smappee.com**.

Smappee n.v.
Evolis 104
8530 Harelbeke
Belgium

2. Safety instructions

Safety warning

Fully read and follow the safety instructions below before you install, service or use your Smappee EV One Home. The installer must ensure that the charging station is installed in accordance with the relevant national and local regulations.

Carrying out activities on this charging station without the relevant knowledge and qualifications can lead to serious accidents and death. Only carry out tasks for which you are qualified and have been fully instructed.

Incorrect installation, repairs or modifications can result in danger to the user and may void the warranty and liability.

Safety precautions

	CAUTION: Risk of electric shock.
	CAUTION: Refer to the accompanying documentation whenever you see this symbol.

Please observe the following safety precautions to avoid potential electric shock, fire, or personal injury:

- The charging station is intended exclusively for charging electric vehicles and, when installed correctly, may be used by untrained individuals.
- Switch off electrical power supply to your charging station before installation or maintenance work.
- Do not use the charging station if damaged / defective.
- Do not immerse the charging station in water or any other liquids.
- Do not expose the charging station to heat, flame or extreme cold.
- Do not attempt to open, repair, or service any parts. Contact Smappee or your service partner for further information.
- Only use the charging station under the specified operating conditions.
- Do not allow children to operate a charging station.
- When a charging station is in use, adult supervision of any children present is required.
- While charging the charging cable must be completely unwound and connected to the electric car without overlapping loops. This to avoid the risk of overheating the charging cable.

Maintenance

- Observe the maintenance schedule.
- Clean the outside only with a dry, clean cloth.
- Do not use abrasive agents or solvents.
- May not be carried out during rain or if air humidity exceeds 95%.

Keeping order

- After charging store the charging cable properly so it does not present a tripping hazard.
- Make sure the charging cable cannot become damaged (kinked, compressed or driven over).
- Do not place any objects on the charging station.

Transport and storage

- Disconnect electrical power supply before removing the charging station for storage or relocation.
- Only transport and store the charging station in its original packaging. No liability for damage incurred will be accepted if the charging station is transported in non-standard packaging.
- Store the charging station in a dry environment within the temperature range specified in the technical specifications.

3. Models

Article no.	EAN	Description
EVO-332-B-E-B	5425036934054	EV One Home 3-Phase 22 kW

4. Components

Components included

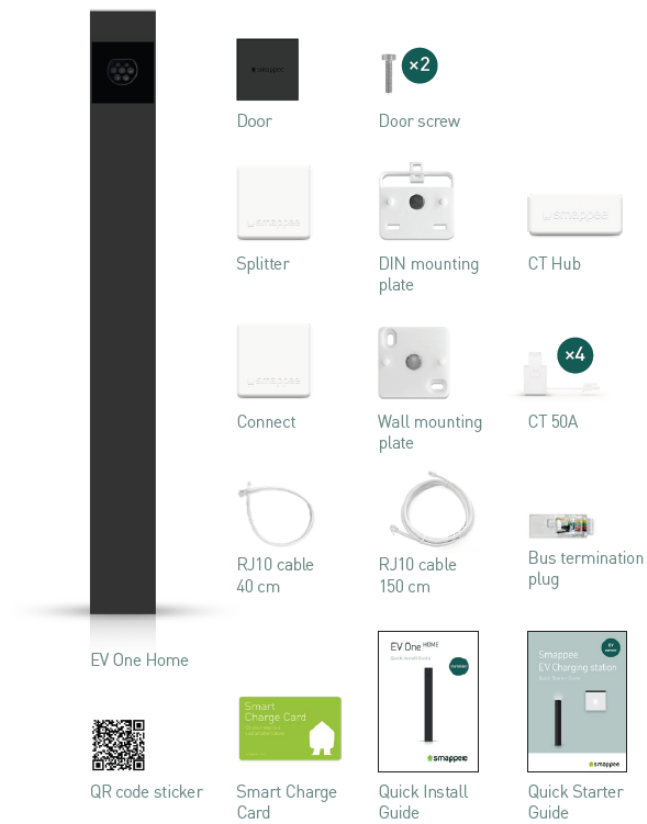

Identification label

The identification label of your charging station is located on the back of the cover plate for the charging socket of the EV One Home.

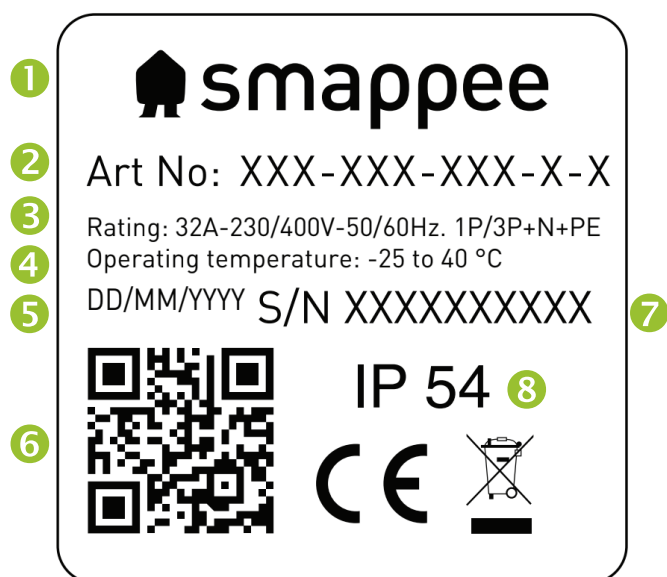

1. Manufacturer
2. Article number
3. Rating
4. Operating temperature
5. Manufacturing date
6. QR code containing article number and serial number
7. Serial number
8. Degree of protection

5. Technical specifications

Feature	Description
Technical features	
Output power	Single-phase: 7.4 kVA Three-phase: 22 kVA
Charge mode	Mode 3 (IEC 61851)
Connection case	Case A and B (Socket) (IEC 61851)
Metering	kWh meter compliant with IEC 62053-21
Integrated Residual Current Protection	Rated operating residual current detection: 6 mA DC and 30 mA AC RCD type A
Supported power systems	TN-C, TN-C-S, TT, IT ¹
Grounding	TN system: PE wire TT system: Independently installed ground electrode < 100 Ohm spreading resistance IT system: connected to a shared reference (common earth) with other metal parts
Rated voltage (U_n)	230/400 VAC
Rated insulation voltage (U_i) of a circuit	500 V
Rated impulse withstand voltage (U_{imp})	4 kV
Rated frequency (f_n)	50 Hz / 60 Hz
Rated current (I_{na})	32 A
Rated current (I_{nc}) of a circuit	32 A
Rated peak withstand current (I_{pk})	6 kA
Rated conditional short-circuit current (I_{cc})	6 kA
EMC classification	Class B
Connection method	AC, permanently connected
Required external circuit breaker(s)	1 x 2P (single-phase) or 1 x 4P (three-phase) breaker of max. 40 A, type B or C

¹ Caution: not all vehicles support the IT system. In that case, or with 3-phase charging a voltage transformer may be required.

Interfaces & Connectivity	
Information status	RGB LED
Session activation	Plug and charge, Scan QR code, Swipe RFID card
Connectivity	Ethernet 100BASE-T, Wi-Fi 2.4 GHz
Communication protocol	OCPP 1.6 JSON, ready for update to OCPP 2.0
Certifications and Standards	
Product certification	CE
Standards	IEC 61851-1 (2017)
Environment	
Enclosure material	Magnelis (structure), aluminium (housing)
Enclosure standard colours	RAL7021 (black grey)
Protection degree	IP 54
Mechanical impact protection	IK10
Pollution degree	3
Electrical safety class	I
Stand-by use	LED brightness 0%: 2 W LED brightness 100%: 5 W
Environmental conditions	Indoor and outdoor use
Operating temperature	-25 °C to 40 °C
Storage temperature	-25 °C to 60 °C
Relative humidity	0 % - 95 %, non-condensing
Maximum installation altitude	0 – 2.000 m
Access	Locations with restricted and non-restricted access
Physical properties	
Dimensions	1100 x 120 x 120 mm
Weight (excluding packaging)	11 kg
Charging cable length	N/A
Supply line connection	Terminal block, flexible conductors up to 6 mm ² or solid conductors up to 10 mm ²
Stationary / moveable	Fixed installation
External design	Enclosed assembly
Mounting method	Floor / Ground-mounted

	<p>The operating temperature assumes the ambient temperature of a product delivered in the default enclosure colour RAL7021 (black grey). Direct exposure to sunlight may have an adverse effect on the temperature range.</p>
	<p>If the product is exposed to lower or higher ambient temperatures, continuous operation cannot be guaranteed. If temperatures exceed the maximum values, the charging station will automatically decrease the charging current to decrease the internal temperature of the charging station.</p> <p>This stabilises the internal temperature and makes it less likely that a transaction will be unexpectedly paused.</p>
	<p>If the product is directly exposed to sunlight, the automated temperature management may automatically start below the maximum ambient temperature. Therefore, wherever possible, avoid exposing the charging station to direct sunlight.</p>
	<p>Where products are exposed to the elements of nature, the enclosure can be subject to gradual aging of the material, which can result in product discolouration over time. Therefore, wherever possible, place the product in a sheltered place to optimise the life of the materials.</p>

6. Preparing the installation

The first step is to prepare the physical installation of the EV One Home as described in this chapter.

Installation prerequisites

- Calculate the existing electrical load to find the maximum operating current for the charging station installation. The Smappee EV One Home is equipped with 1 connector which needs to be powered.
- Obtain all necessary permits from the relevant local authority.
- Refer to local wiring regulations to select the conductor sizes and use only copper conductors.
- Make sure that the installation area of the charging station is adequate for usability and ventilation purposes.
- Use the correct tools and provide sufficient material resources and protection measures.

Power supply

- The appropriate wire gauge of the supply cable depends on the power rating and distance between the meter cabinet and the charging station. The voltage drop must not exceed 5%. It is advisable to have a maximum voltage drop of 3 %.
- The maximum wire gauge that can be fitted is 6 mm² in case of flexible conductors or 10 mm² when solid conductors are used.
- The power supply connection must be protected against short-circuiting and over-current with an individual circuit breaker. This circuit breaker must be 2-pole (for single-phase) or 4-pole (three-phase), curve B or C and have a current rating of maximum 40 A (or otherwise in compliance with local standards and regulations).
- When the power supply and the charging station are part of a TN-S system, the station must be grounded via the main distributor.
- Route the power supply cables to the position where the charging station will be installed together with an Ethernet cable for the internet connection (if applicable).
- Make sure that there is at least 100 cm cable available at the location of the EV One Home to be able to connect it easily internally.
- Local regulations may be applicable and can vary depending upon the region or country.

The maximum power rating for each connector is specified in the table below.

Power per connector	Connection	Input current	Output current
7.4 kW	1-phase	1 x 32 A	1 x 32 A
22 kW	3-phase	3 x 32 A	3 x 32 A

Route communication cable

The EV One Home requires a communication cable between the EV One Home and the distribution panel where the CT measurements and Connect gateway are placed. To do this, four twisted pairs of a Cat 5 or Cat 6 networking cable are used. The Cat 5/6 cable should be connected on the RJ-45 port of the relay board of the EV One Home with the 'A+B' marking.

Tools (not included)

- Screwdrivers
- 2,5 mm Hex screwdriver
- 8 mm socket wrench with extension bar
- Multimeter and earth ground meter
- Wire stripper and cutter.
- Needle-nose pliers.
- Ferrules crimper (when using stranded power supply cables)
- RJ45 crimping tool

Supplies (not included)

- CAT 5/6 Ethernet cable and two RJ45 connectors for wired communication cable
- Power supply cables
- Ferrules (6 mm²), when using stranded power supply cables
- Circuit breaker (max. 40 A)

7. Installation and activation

This procedure describes the required steps for the physical installation of the EV One Home.

	CAUTION: The installation must be carried out by a qualified professional who has read this manual and works in compliance with IEC 60364 standards. Neglecting this may lead to severe injuries or hazardous situations while working with electricity.
	CAUTION: The electric system must be entirely disconnected from every power source prior to performing installation or maintenance work. Make sure it is not possible to connect the electric current during installation. Put up caution tape and warning signs to mark the work areas. Make sure no unauthorised people can enter the work areas.
	CAUTION: The charging station contains electric components that may still contain electrical charge after being disconnected. Wait at least 10 seconds after disconnection before commencing work.
	CAUTION: Adaptors or conversion adaptors and cord extension sets are not allowed to be used.

Prepare the mounting foundation

The Smappee EV One is designed to be installed at ground level using the supplied anchor.

Foresee a power supply & Ethernet cable between the EV One Home and the distribution panel. Make sure the power supply and Ethernet cable can be positioned through the inner structure of the EV One.

Depending on the subsoil, the size may vary. Please refer to the technical specifications of size and weight to determine the dimensions for a solid foundation for the EV One.

Unbox the EV One

	When installing multiple EV One units, it is important not to mix the components of the different units. In the box of each unit, several loose components are found, but these are linked to that specific unit. Mixing those loose components leads to the inability to successfully activate and use the EV One.
-------------------------------------------------------------------------------------	----------------------------------------------------------------------------------------------------------------------------------------------------------------------------------------------------------------------------------------------------------------------------------------------------------------------------

For safe and compact transport of the EV One, the outer housing is mounted to the EV One and the anchor components are mounted inside the inner structure.

- a. Take the EV One out of its packaging.

- b. Unscrew the two bottom screws and slide the outer housing upwards, off the internal structure. Make sure to place the screws in a secure place as these are needed to later mount the outer housing.

Note that the electronics of the RFID card (top) are protected by extra transparent plastic. Check to see if this plastic is in place and reattach it if necessary. The warranty is void if this plastic is removed.

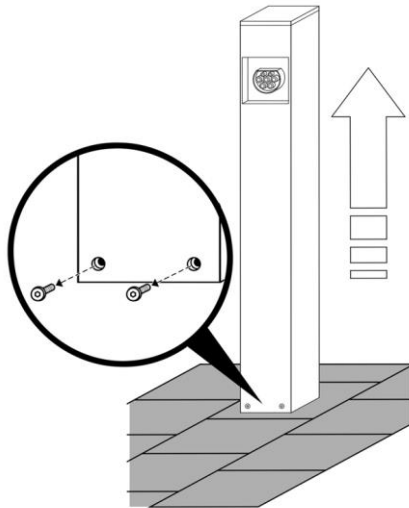

- c. When installation is spread over time or there is a risk of damaging the electronics while mounting the EV One, we advise to temporarily remove the top half of the EV One and set it aside in a safe location. To do so, unscrew the four nuts uniting the two parts of the inner structure. No wires need to be disconnected, nor components removed.

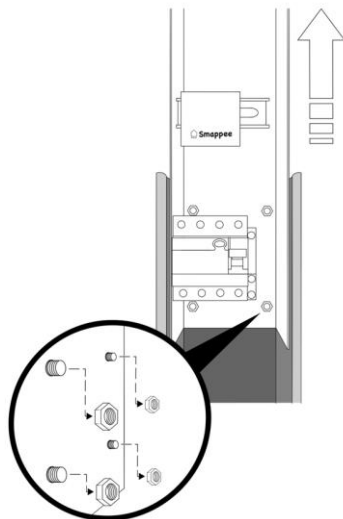

Mount the anchors

- a. Remove the two nuts holding the three anchor components to the inner structure. Remove all three components from the inner structure as a whole.
- b. Assemble the anchor onto the inner structure. The nuts to mount the anchor components are present on the inner structure. Use a M8 socket wrench to tighten the nuts.
 - First, mount the anchor component with the lip. This one needs to be mounted on the open side of the inner structure.
 - The two other components are mounted on the left and right sides of the inner structure.
 - One side of the inner structure does not have an anchor component.

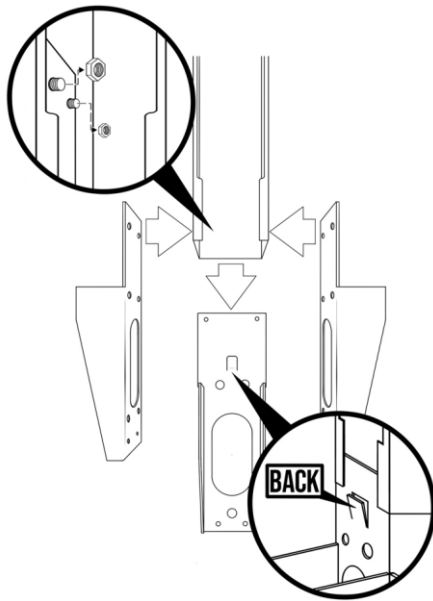

Place the EV One in position

- a. Place the EV One in the prepared foundation hole.
- b. Route the power supply and communication cable through the anchor and into the EV One. Make sure that there is at least 100 cm cable available at the location of the EV One to be able to easily connect it internally.
- c. Make sure the inner structure is standing level in all directions.
- d. Verify that the bottom of the EV One is flush with the ground level. The lip on the anchor can be used as a reference. The top of the lip should be level or slightly below ground level.
- e. Fill the hole with concrete and let it cure.

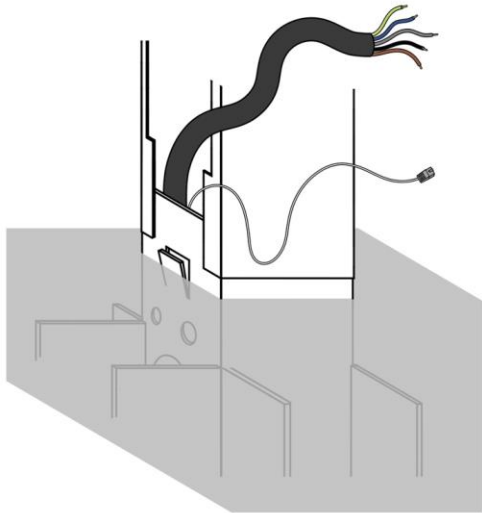

Power supply connection

- a. If the top half of the inner structure was removed while placing the EV One in position, reattach it to the inner structure, using the four nuts.
- b. Cut the power supply cable to adequate length and add the ferrules to each conductor (if needed).
- c. Measure the resistance of the grounding circuit and make sure that it is within acceptable limits. If necessary, install a grounding point closer to the charging station.
- d. Connect each power supply cable to the integrated 30 mA RCD. Make sure to follow the correct connection order. Going from left to right this should be: L3 (grey), L2 (black), L1 (brown) and N (blue). The PE is connected directly to the terminal block just next to the RCD. If you have a single-phase power supply, only the L1, N and PE need to be connected.

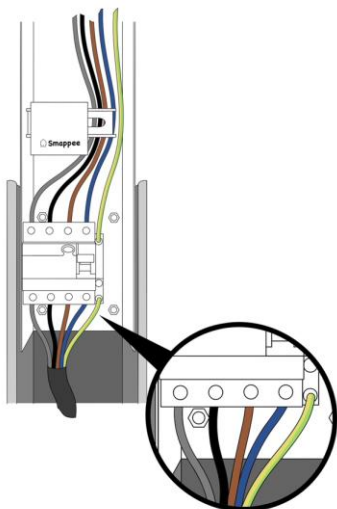

Communication cable

Connect the UTP Communication cable to the RJ-45 port on the relay board labelled with 'A+B'.

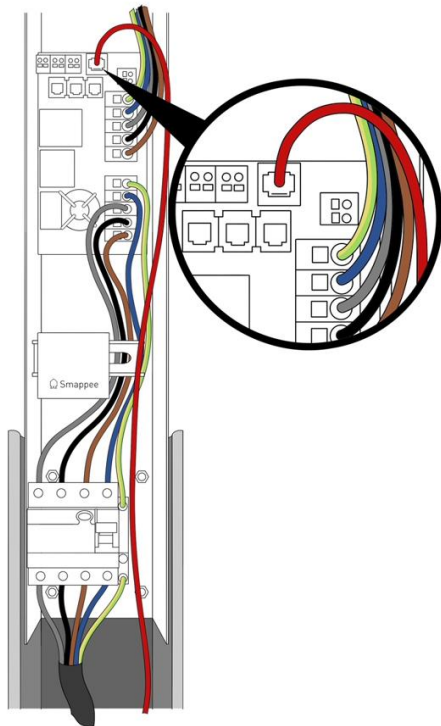

Installation in distribution panel

This chapter describes the installation of the Infinity components in the distribution panel. These components enable overload protection & solar optimization supplied with the EV One Home.



The EV One Home package comes with the required Smappee Infinity components to be installed in the distribution panel to measure the main feeder (total grid consumption) and single-phase solar inverter.

If a **three-phase solar inverter**, or **multiple inverters** are present, the EV One Solar Add-on can be purchased. De **EV One Solar Add-on** contains two extra 50 A CTs and one CT Hub.

Depending on the EV One Home type (1-phase or 3-phase), the included Smappee Infinity components varies:

- EV One Home 1-Phase:
 - 1 x Connect
 - 1 x CT Hub
 - 3 x CT 50A (1x grid + 1x solar + 1x EV measurement)
 - 1 x Smappee splitter
- EV One Home 3-Phase:
 - 1 x Connect
 - 1 x CT Hub
 - 4 x CT 50A (3x grid + 1x solar measurement)
 - 1 x Solid Core 3-Phase CT (EV measurement)
 - 1 x Smappee splitter



If additional CT measurements need to be added, standard Infinity hardware (CT Hubs and CTs) can be purchased and installed in addition to the EV One Home components. Always keep the Smappee Infinity installation guidelines in mind.

For installation of these components, please refer to the diagrams on the next page.

The main installation steps include:

- a. Install the 40 A circuit breaker (not supplied) according to local regulations. In case of a three-phase EV One Home: install the supplied solid-core CT together with the circuit breaker.
- b. Install the CTs as indicated on the diagrams on the next page. Connect these to the supplied CT Hub.
- c. Install the Smappee Connect and EV One Home splitter. The Smappee Connect should be placed inside or near the distribution panel. It requires a stable internet connection via Wi-Fi or Ethernet.
- d. Connect the A- and B-bus cables as indicated on the diagram. Connect the Cat 5/6 communication cable to the RJ45 port of the splitter.



Ensure that the CT Hub(s) are connected to the A-port of the Smappee Splitter and the Smappee Connect to the B-port of the Splitter. Also check that the Cat 5/6 communication cable is connected to the splitter and NOT to the Smappee Connect.

Connection diagram EV One Home – 3-phase (3P+N)

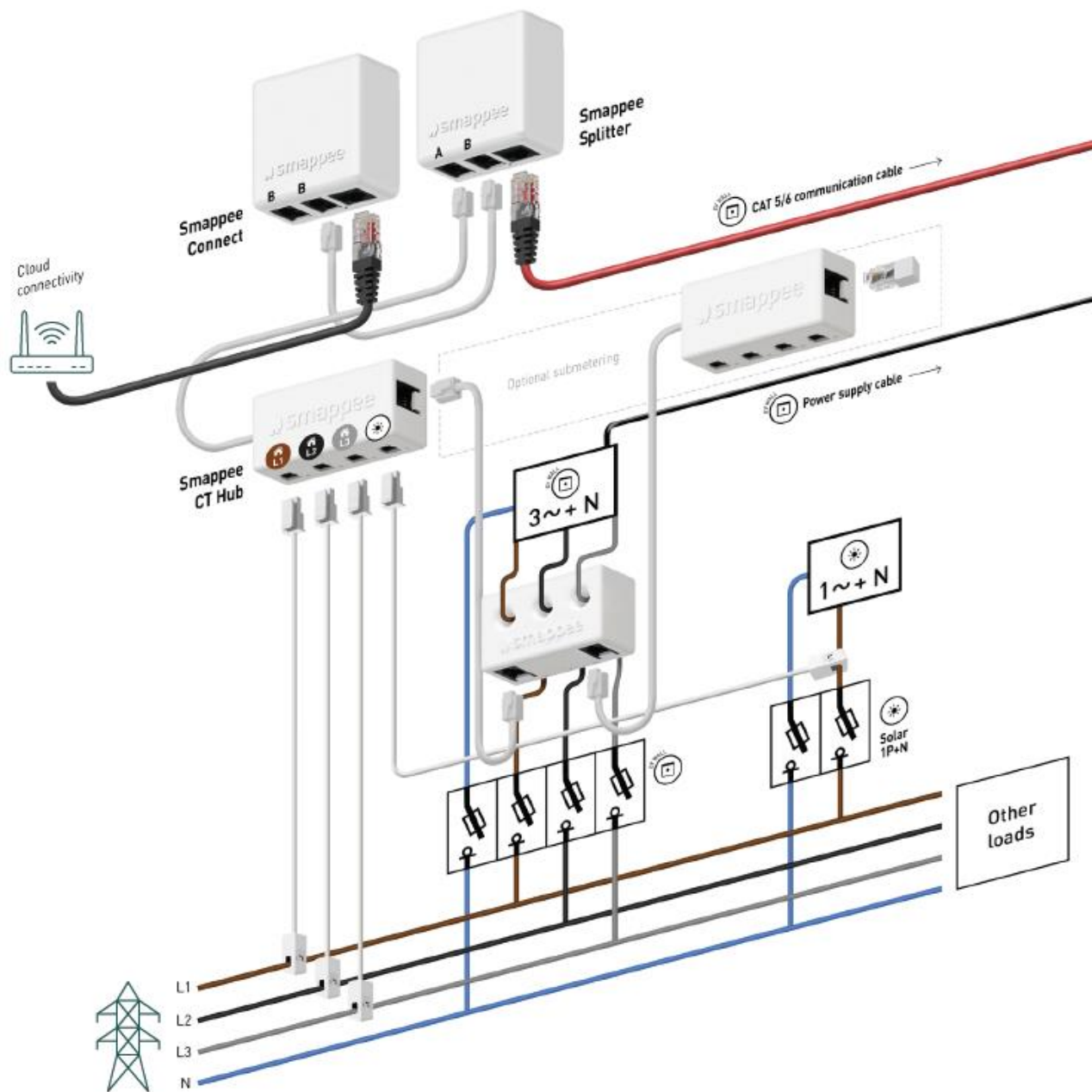

It is possible to connect a three-phase EV One Home to a single-phase installation. In this case, you select single-phase in the app and follow the instructions in the app.

IMPORTANT notes for 3P (3 x 230 V) – Delta topology



This section is only relevant if you have a delta grid topology, which is only found in some parts of Belgium, Norway and France. If this is not applicable, you can skip this section.

When an EV One Home is installed in a residential installation with a 3P (3 x 230 V) Delta grid connection, some additional requirements need to be taken into account. You can verify whether you have this topology by checking the grid connection to see if the following are true:

- There is no neutral wire.
- The voltage between two phases is approximately 230 V.
- The voltage between a phase and earth is approximately 130 V.

Some EVs are not compatible with this type of grid connection due to a built-in security in the EV. Contact your EV manufacturer for more information.

The security feature that some EVs have is a voltage check between the phase that is connected as neutral and the ground. If this is not 0 volts, the car won't charge. The presence of this security feature may vary for each manufacturer and for each model.

As there is no neutral wire available in this topology, the L3 will be used as neutral. In this case, some EVs will be able to charge dual phase (using both L1 and L2) and some will only charge single phase. In practice, this may limit the maximum charging power. This again varies for each EV manufacturer and each model.

If your EV is not compatible with this grid topology, or if you would like to achieve higher charging power than what is possible on a delta grid topology, you can install a transformer. This transformer will convert the 3 x 230 V delta topology to a standard 3 x 400 V star topology.

Without transformer

If you are connecting the charging station directly to the 3 x 230 V delta grid, without transformer, please refer to the diagrams below.

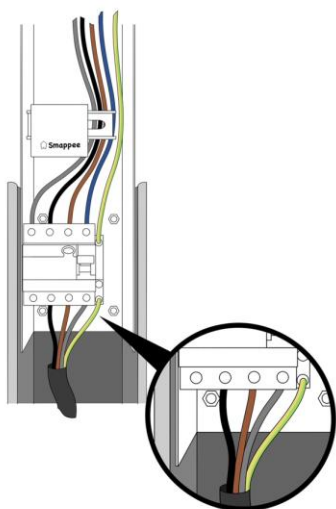

We highly recommend that you test compatibility with the customer's EV during installation. If you have connected the EV One Home as shown above but the EV will not charge, you can try to disconnect the L2 cable going to the socket.

Do not disconnect the L2 of the power supply cable!

If you install an EV One Home on a 3 x 230 V delta grid connection without transformer, the Infinity components in the distribution cabinet should be connected as shown below:

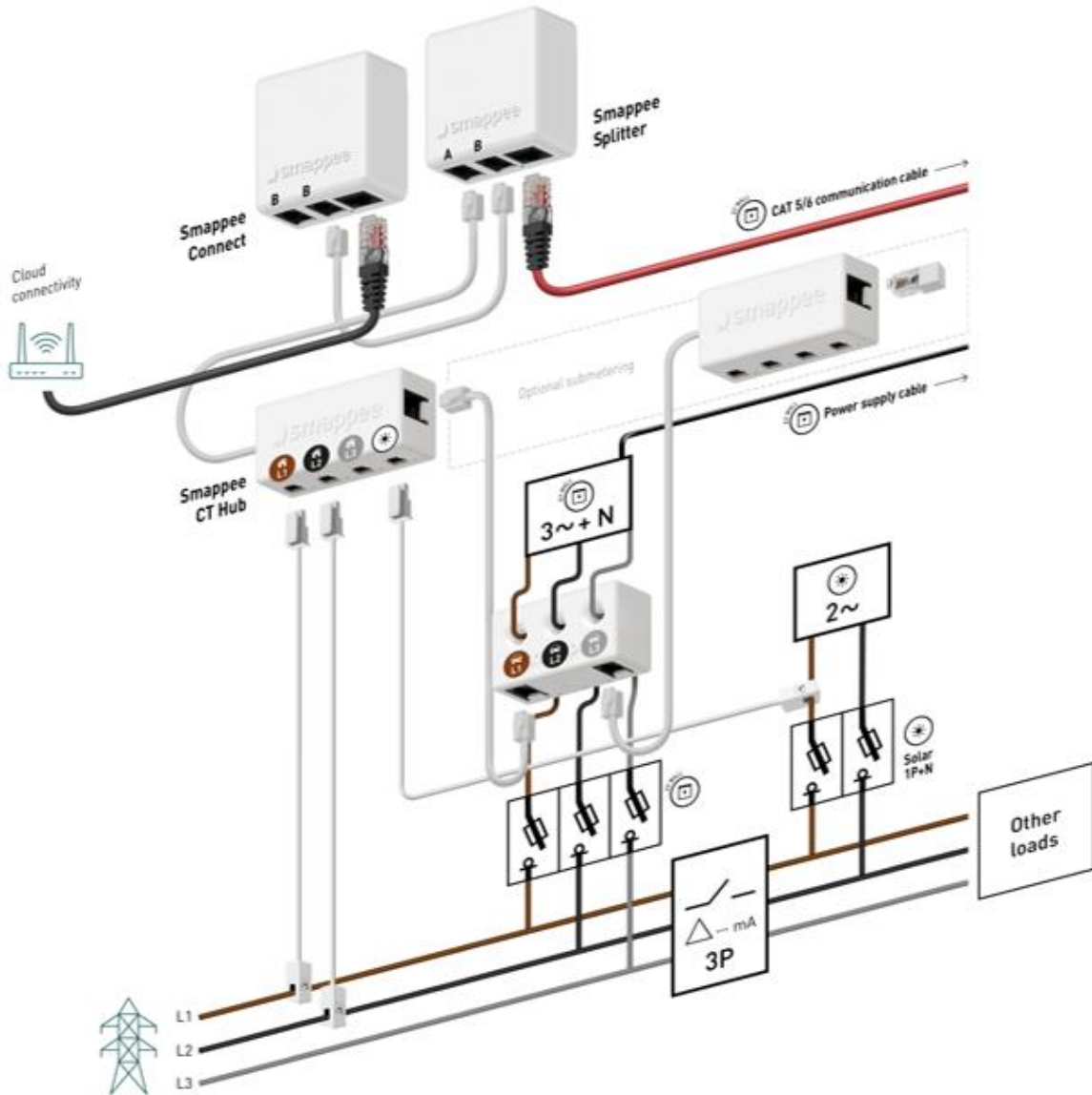

Note that when you measure single-phase loads or solar panels, you must connect and configure the CT(s) as shown below:

Single phase consumer/producer powered by	Connect the clamp around	Phase measured by this CT
L1 and L3	L1	L1
L2 and L3	L2	L2
L1 and L2	L1	L3

With transformer

If a transformer is used to convert the 3 x 230 V delta connection to a standard 3 x 400 V star with neutral, then the charging station's power supply can be connected as usual. Please refer to the pictures on previous pages for this. The connection in the distribution cabinet is still a little different, as shown in the diagram below.



When a transformer is used in combination with a 3 x 230 V delta topology, the purchase of an additional Smappee Power box is required. This will be placed inside the distribution panel. In this case, the Power Box inside the EV One Home becomes redundant and both RJ10 cables should be disconnected.

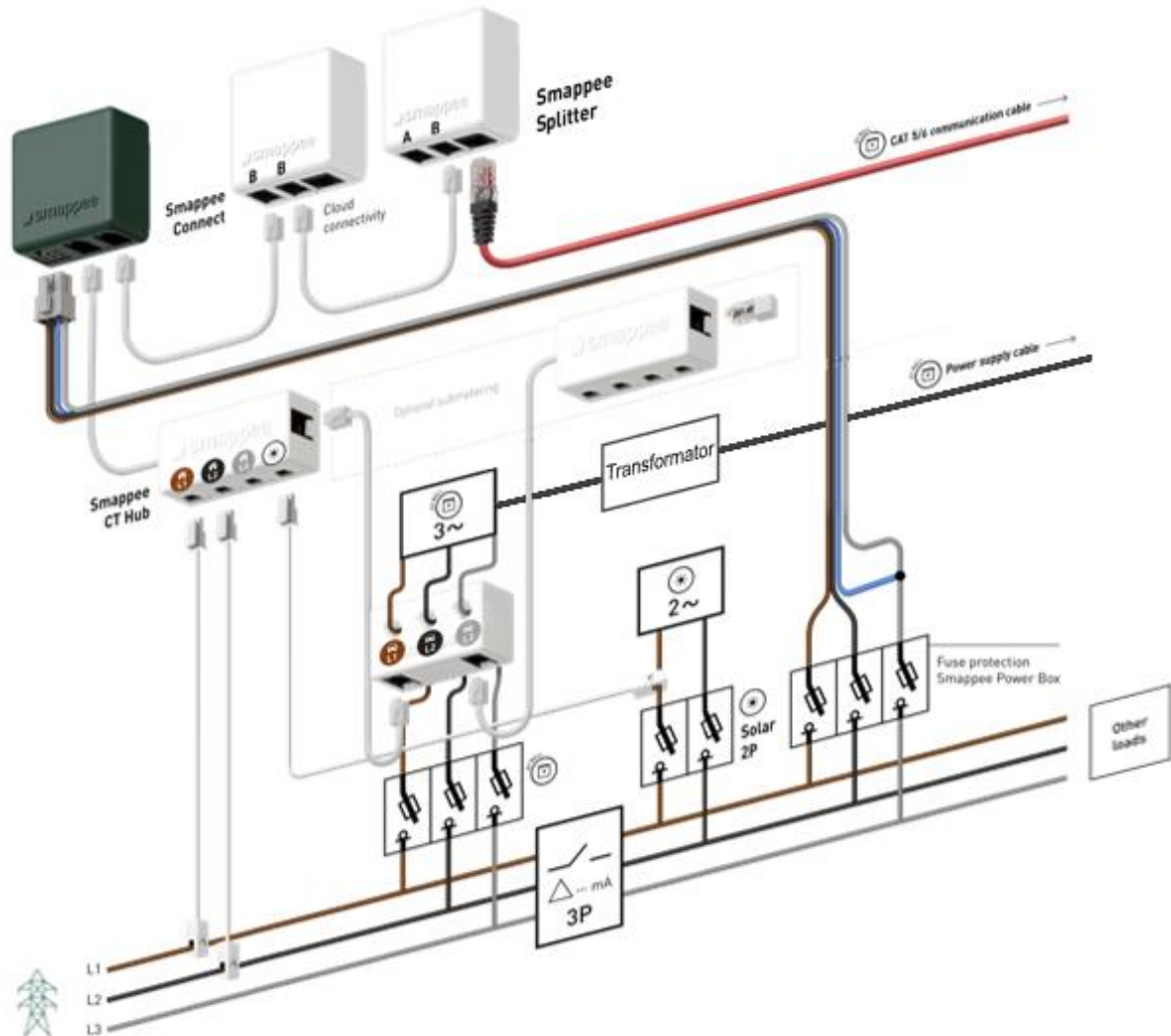

Note that when you measure single-phase loads or solar panels, you must connect and configure the CT(s) as shown below:

Single phase consumer/producer powered by	Connect the clamp around	Phase measured by this CT
L1 and L3	L1	L1
L2 and L3	L2	L2
L1 and L2	L1	L3

Switching on the EV One Home

- a. Check all connections are secure.



Make sure that the RCD (earth leakage) switch is set to the 'On' position before closing the EV One Home

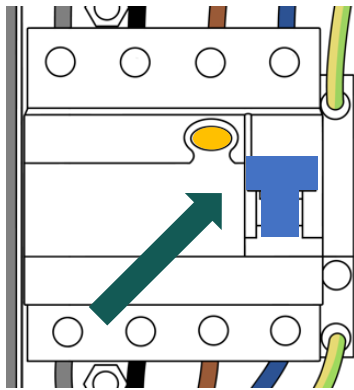

- b. Power-up the EV One Home.
- c. Check the status LEDs:
 - Connect: blue flashing
 - Power Box: green flashing light (1 x per 3 seconds)

Activation

This procedure is done with the Smappee mobile app. You can download this from the Apple App Store for iOS or the Google Play store for Android phones.



The Smappee App will guide you through the various steps to fill in all the required information.

- Log in to the Smappee App with the given Smappee username or create a new user account.
- Install a Smappee car charging station.
- Follow the steps shown in the mobile app.

	<p>The settings of your charging station can be adjusted in the Smappee Mobile app or Dashboard.</p> <ul style="list-style-type: none">• Smappee Mobile App: Name, Maximum current per connector, Charging speed per connector and LED brightness• Dashboard: Name, Maximum current per connector, Phase assignment per connector, Charging speed per connector and LED brightness
-----------------------------------------------------------------------------------	-----------------------------------------------------------------------------------------------------------------------------------------------------------------------------------------------------------------------------------------------------------------------------------------------------------------------------------------------------------------------------------------------------------

Closure



Make sure that the RCD switch is set to the 'On' position before closing the EV One Home

- a. Slide the housing over the inner structure. Make sure the opening for the socket is in line with the socket on the inner structure.
The housing will skew between the inner structure and the lip provided on one of the anchor parts.
- b. Tighten the screws at the bottom of the housing. These screws are removed at the beginning of the installation.
- c. Attach the door to protect the socket using the provided screws. Place door in a horizontal position for easiest access to mount the screws. Verify the door can move without friction.

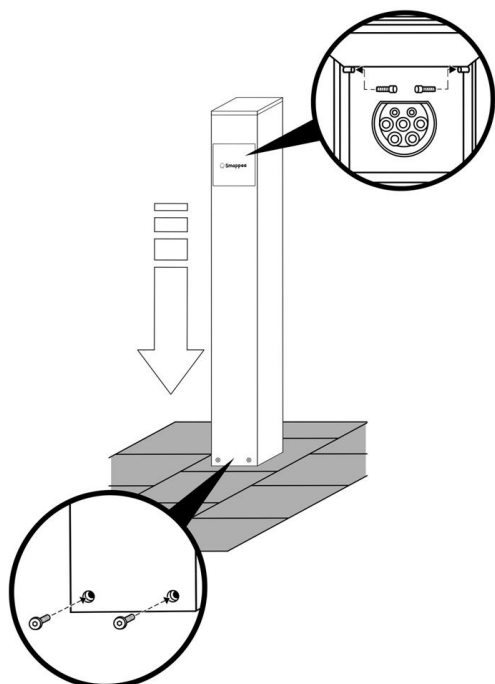

8. Using the EV One Home

There are three ways of charging using a Smappee EV One Home:

1. Plug and charge: Simply connect your cable and start charging.
2. Swipe and charge: Connect the cable, swipe your card and start charging.
3. Scan and charge: Connect the cable, scan the QR code in the Smappee app and start charging.

Below you can find the different charging sequences.

	Each EV One Home that is installed and activated is Plug and charge. Changing the Session Activation Method is done using the Smappee Dashboard. Changing the authentication methods can be done remotely.
	Scan and charge and Swipe and charge (with Smappee CSMS) can only be used when a Smappee Payment Agreement has been signed. See this article for more info.

Plug and charge

The charging station is freely accessible without the need to authorize. Anyone can plug their car into the charger and start charging for free.

Start charging

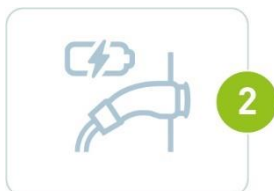

Stop charging

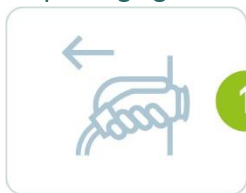

Swipe and charge

Charging sessions can be started using an RFID card. You can either use a Smappee Smart Charge Card for free charging or (if activated) a third party eMSP card to pay for charging sessions.

The RFID reader is found on top of the EV One Home, together with the ambient light.

- **Whitelist:** charging is free with a Smappee Smart Charge Card or any other authorized RFID card. Once the charging cable is plugged-in, the user simply swipes their RFID card and the free charging session begins. All authorized cards must first be added to the whitelist using the 'Whitelisting' card on dashboard.smappee.net. See [this](#) article for more information. Cards can be ordered via the Smappee dashboard.
- **Public charging:** Other EV drivers can use this charging station and pay with an RFID card / token from a third-party eMSP. This can be done through Smappee's own CPO or through a third-party CPO. Public charging is activated using the Smappee dashboard. See the [Smappee Academy](#) for more information.
- **Split Billing:** This is aimed at employees who charge their company car at home and need to be reimbursed for the electricity consumption. Split billing agreements must be made for each employee. Starting a charging session is similar to whitelisting but at the end of each month, Smappee Services will send a bill for all employees' charging sessions to the company. All individual employees will be reimbursed according to the amount of kWh charged. Split billing is activated using the Smappee dashboard. See [this](#) article or the [Smappee Academy](#) for more information.

Start charging



Stop charging



Scan and charge

The user pays by credit card (Visa or Mastercard) using the Smappee app. They scan the QR code shown on the charging station and the app will guide them through the process of starting the charging session. It is also possible to set discount rates for specific users. Scan and charge is activated using the Smappee dashboard. See the [Smappee Academy](#) for more information.

Start charging

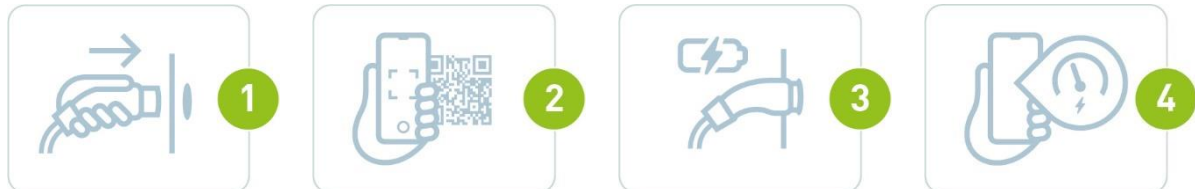

Stop charging



More information on how to use the Smappee EV One Home can be found on: support.smappee.com/hc > Smappee EV Line

LED status

LED colour	LED status	Meaning	Action of the user
	White continuous	The Smappee EV One Home is available.	Connect your EV with the Smappee EV One Home.
	Blue continuous	Your EV is connected with the Smappee EV One Home, but is not yet charging.	<ul style="list-style-type: none"> • If using an RFID, scan your charge card and wait until the LED turns flashing blue. • If using QR codes, scan the QR code and wait until the LED is green pulsing. • If no authorisation is required, wait until the LED becomes green pulsing.
	Blue flashing	Your RFID card is being verified.	Wait until the LED is green pulsing.
	Green pulsing	The Smappee EV One Home is charging your EV.	Your EV is being charged.
	Green continuous	The EV is now fully charged.	Disconnect the cable.
	Green blinking	Charing session is paused by Smappee Smart Charging	This is informative, no action required.
	Red continuous	The Smappee EV One Home is unavailable.	Check the manual or contact your supplier for more info and further steps.
	Red flashing	Your charge card is not authorised.	Contact your charge card supplier.

Declaration of conformity

We,

Smappee nv
Evolis 104
B-8530 Harelbeke
Belgium

following the provision of the following EC Directives:

- 2014/35/EU The Low Voltage Directive
- 2014/30/EU The Electromagnetic Compatibility Directive
- 2011/65/EU RoHS Directive

hereby declare that the product:

EVOB-332-B-E-B, EVOE-332-B-E-B, EVO-332-B-E-B, EVOL-332-B-E-B

is in conformity with the applicable requirements of the following documents

- * Emissions:
(EN61326-1 : 2013)
Radiated Emission: EN 55011:2009 / EN 55032:2015 (Class B)
Conducted Emission: EN 55011:2009 / EN 55032:2015 (Class B)
Harmonic current Emission: EN 61000-3-2:2005 +A1:2008 + A2:2009
Flicker: EN 61000-3-3:2008
- * Immunity:
(EN61326-1 : 2013)
ESD : EN 61000-4-2:2008 / EN 61000-4-2 :2009
Radiated immunity : EN 61000-4-3:2006 + A1:2007 + A2: 2010
Power frequency magnetic field: EN 61000-4-8:2009
Voltage dips/interruptions: EN 61000-4-11:2004
Common Mode Immunity: EN 61000-4-6:2008 / EN 61000-4-6:2009
Burst : EN 61000-4-4:2004 / EN 61000-4-4:2012
Surge: EN 61000-4-5:2005 / EN 61000-4-5:2006
- * Safety:
Metering Function : IEC 61010-1 Ed 3.0 (2010-06) + A1:2016
AC Charging equipment : IEC 61851-1 (2017) / EN61558-1
- * Other applicable standards and certifications: IEC 60364, IEC 62192-1, IEC 62192-2

Harelbeke, Belgium, May 31, 2023

Authorized signatory



Stefan Grosjean
CEO