

SECTION B-B

Printing decoration:  
 Maximum printing length surface jar : 313 cm  
 Maximum printing height : 24 mm  
 IIP is not responsible for eventual possible mistakes on this drawing.

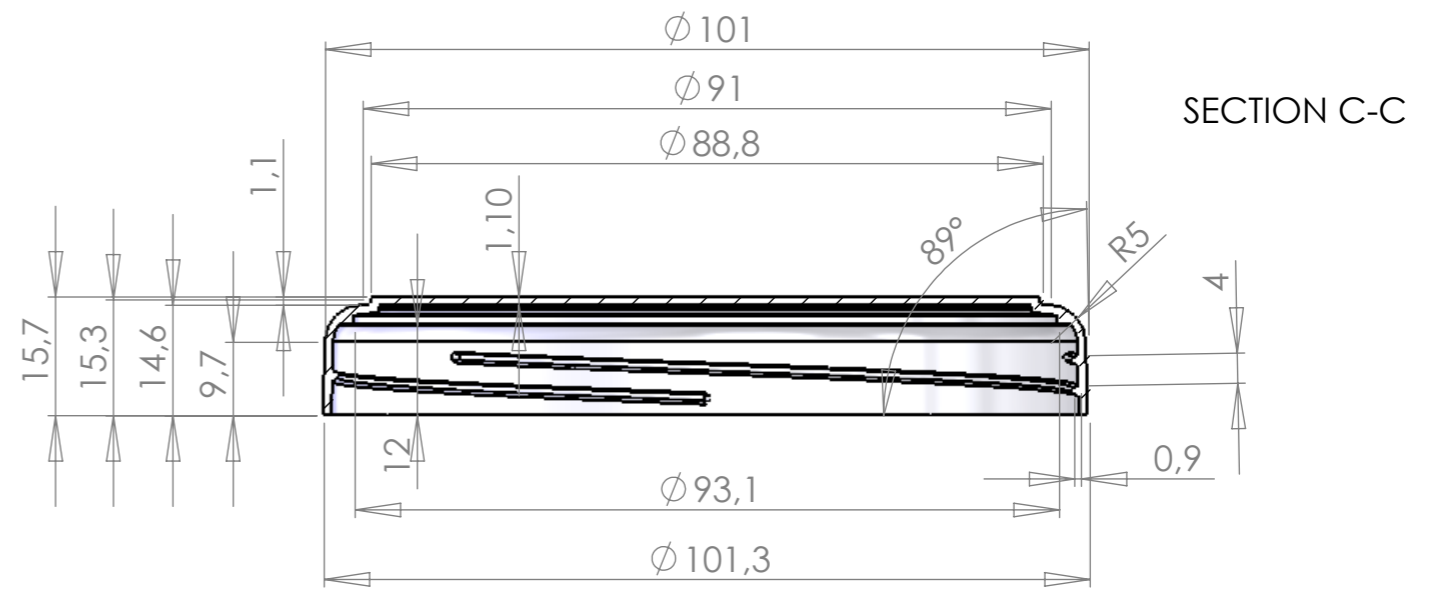

SECTION C-C

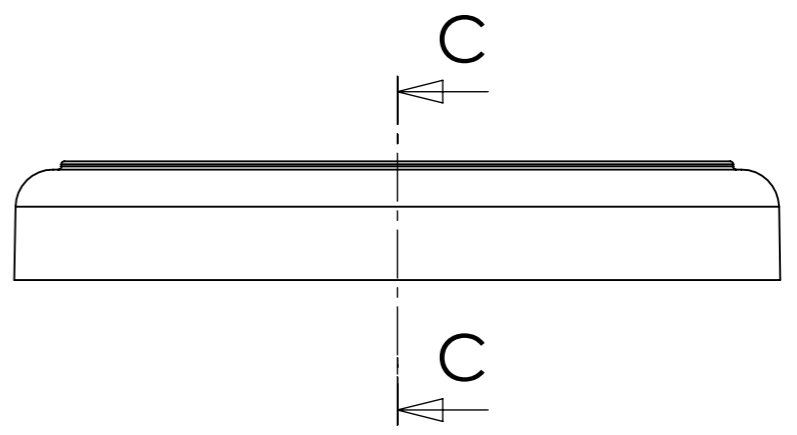
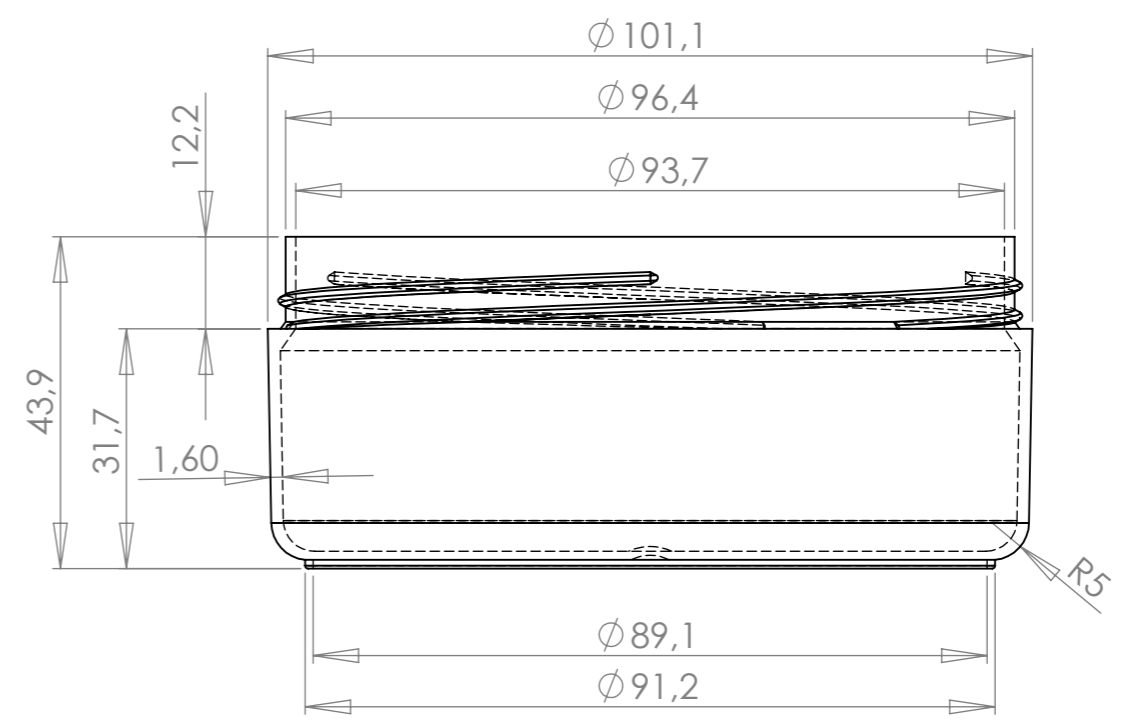

**Industrial Injection Plastics**  
 Meerbos 14  
 9260 Wichelen  
 Tel: +32 52 42 33 19 Fax: +32 52 42 81 03  
 e-mail: jan@iip.be

DATUM	7/05/2013
MATERIAAL	--
AFWERKINGNo	--
DO NOT SCALE DRAWING	

250 ml JAR ART NR 0413	
SIZE	A
Bestandsnaam tekening:	samenstelling POT en DEKSEL 250 ml
SCALE:1:1	Gewicht:
SHEET 1 OF 1	