

Connection Examples

#1 = Continuous Sound +ve
#2 = Alternating Sound +ve
GND = Common -ve
Tamper x 2 = Lid and mounting surface tamper.

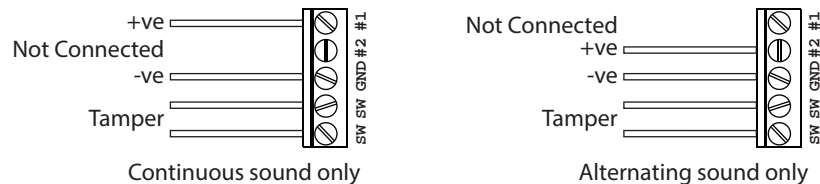

Specifications

Technical

Nominal Voltage: 13.6 volts DC
Voltage range: 9-15 volts DC
Sounder Type: Tone (Piezo)
Sound output level : 110 dB (A) @ 1 metre
Continuous Sound only current: 107mA @ 13.6 volts dc
Alternating Sound only current: 90mA @ 13.6 volts dc
(110mA @15 volts dc/ 80mA @ 9 volts dc)
Temperature Range: -15° C to +40° C
Sound Duration: Determined by control panel.

Tamper Detection

Lid and mounting surface removal.

Housing

Base Material: ABS
Lid Material: ABS
Dimension (mm): 115mm x 115mm x 32mm

EN50131-1:2006 + A1:2009

:Security Grade 3 Environmental Class II

EN50131-4:2009

Warning device type : Internal Remotely Powered

Safety Precautions

Always observe local regulations when disposing of this unit
Plastic bags can suffocate, always dispose of packaging carefully

Environmental Advice.

This product is covered by current WEEE regulations. Please consider the effect on the environment when disposing of it. Do not put in a domestic waste bin. Only dispose of at an appointed recycling centre.



RoHS compliant.

SO/ALTO*/G/S5

* Denotes Colour

ALTO



Internal Warning Device

Low profile design.
110 dB sound output.
Selectable alternating or continuous tone.
Low current consumption.
Tamper protected lid and mounting.

Operating and Installation Instructions

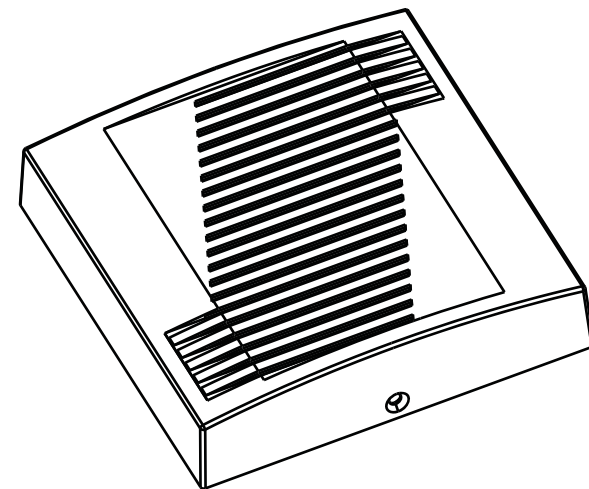

Description

This remotely powered internal sounder can be installed in security systems up to and including Grade 3 Environmental class II in accordance with EN50131:2006 + A1:2009. It is certified by Telefication to EN50131-4:2009. The warning device gives an audible signal of alarm activation. The sound output is selectable for either alternating or continuous tone. It is also protected against tampering by means of lid removal and removal from the mounting surface.

CQR Security, 125, Pasture Road, Moreton, Wirral. CH46 4TH, United Kingdom

Tel: +44 (0) 151 606 9595 Support: +44 (0) 151 606 6311 email: info@cqr.co.uk Web <http://www.cqr.co.uk>

Features

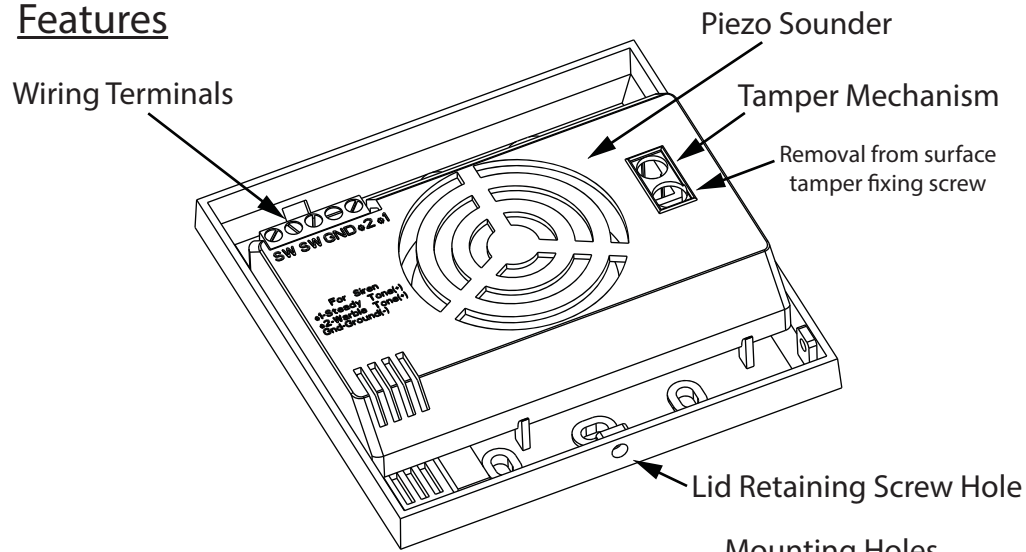

Sound Louvres

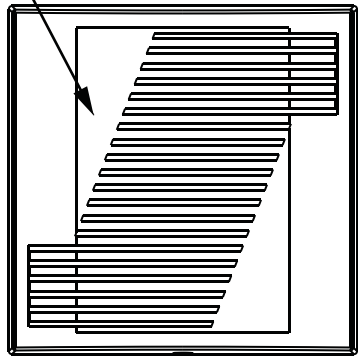

Front

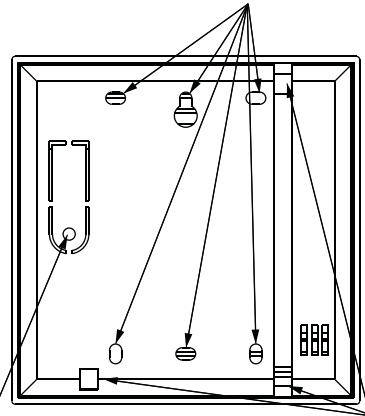

Mounting Holes.

Removal from surface
tamper fixing screw

Back

Cable Entry

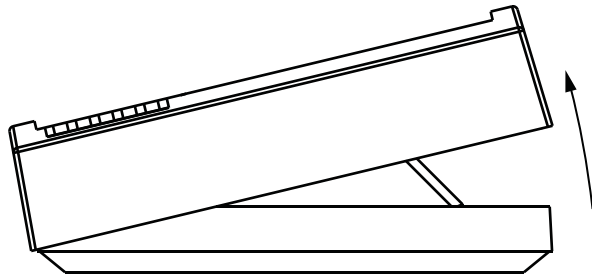

Open Lid

Mounting Instructions

Identify a suitable mounting location for the sounder on a flat wall. To remove the lid, unscrew the retaining screw on the front face, grip both sides and hinge the lid up as shown opposite. Using the sounder as a template, mark the fixing points on the surface of the selected location. Drill 4 x 5mm holes for the enclosed wall plugs, insert the wall plugs into the holes, feed the cable through the cable entry point on the sounder and using the enclosed screws, fix the sounder to the selected location.

Please note in order for the sounders tamper protection to detect unauthorised removal from the mounting surface, the tamper fixing screw hole must be used, do not over tighten this screw as this is a one time operation and if broken or damaged the sounder will need to be replaced.

Wiring Options

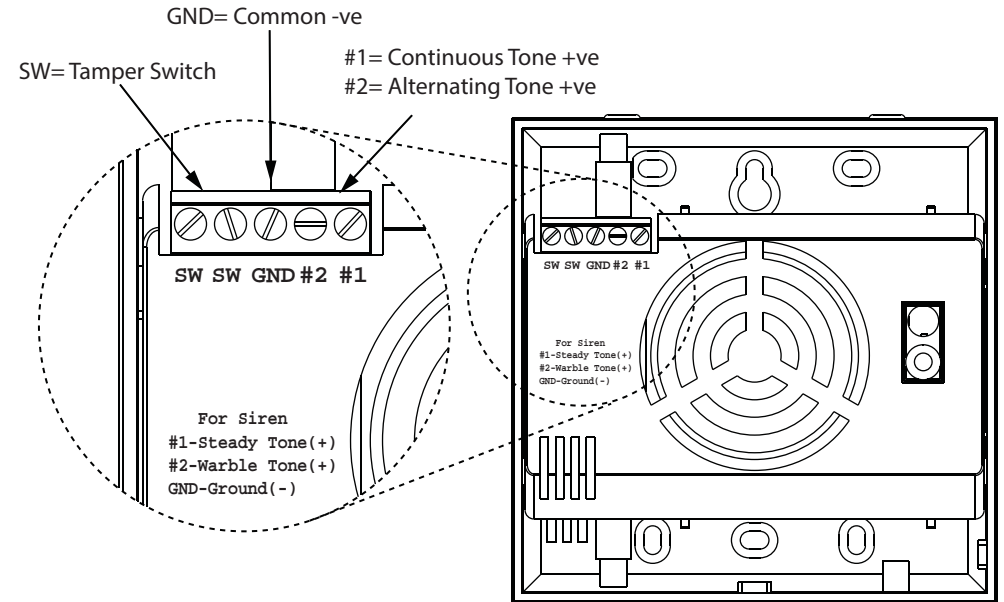

There are five terminals for the connection of wires as shown above. To activate either the alternating or continuous sound, connect a negative to the common negative terminal (GND) and connect a positive to the appropriate positive terminal (#1 or #2). To stop the sound, remove the positive or negative supply.

Please note that continuous tone does not comply with EN50131-4.