

TOLERANCES UNLESS OTHERWISE STATED

0 DEC. PLACE	±0.5	2 DEC. PLACES	±0.1
1 DEC. PLACE	±0.2	ANGULAR	±1°

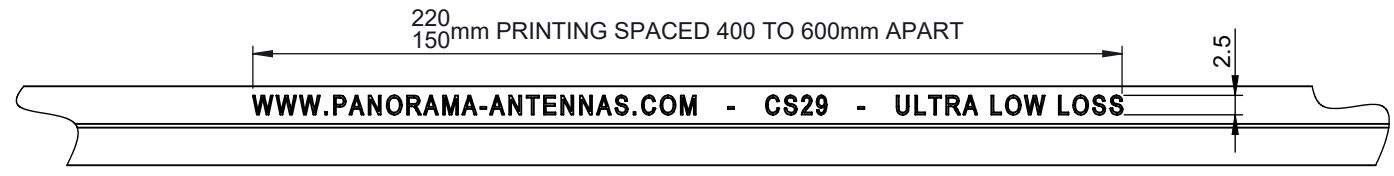

WHITE TEXT TO BE PRINTED ON CABLE SHEATH AT REGULAR INTERVALS SHOWN. SEE NOTE 3.

CABLE SPECIFICATION VALUES:

- CHARACTERISTIC IMPEDANCE:-
50Ω ±2Ω @ 1GHz
50Ω ±4Ω @ 2GHz
- ATTENUATION:-
NO GREATER THAN 4dB PER 10m AT 1 GHz.
NO GREATER THAN 5.5dB PER 10m AT 2GHz.
- BRAID RESISTANCE PER 10m LESS THAN 160mΩ.
- SHIELDING EFFECTIVENESS ACCORDING TO IEC61196 TO BE < -85dB AT 30-10000 MHz.

SPECIFICATION NOTES:

- ELECTRICAL TEST - EACH CABLE. CENTRE CONDUCTOR/OUTER SCREEN ISOLATION 1kV MIN. CENTRE CONDUCTOR END TO END TEST.
- TENSILE PULL TEST SAMPLE/ASSEMBLY PER 3000 BATCH. PULLING LOAD - CONNECTOR BODY - 5Kg. PULLING LOAD - CENTRE PIN - 2Kg.
- CS29 CABLE PERFORMANCE TEST SAMPLE PER 10000 m BATCH. IMPEDANCE 50Ω ±2Ω @ 1GHz. & 50Ω ±4Ω @ 2GHz. LOSS NO GREATER THAN 0.4dB/m @ 1GHz. & 0.55dB/m @ 2GHz.

GENERAL NOTES:-

- ALL MATERIALS SUPPLIED MUST BE RoHS2 (DIRECTIVE 2011/65/EU) COMPLIANT AND MUST NOT CONTAIN ANY SUBSTANCES OF VERY HIGH CONCERN (SVHCs) LISTED UNDER REACH OR POLY-AROMATIC HYDROCARBONS (PAHs), OR PERSISTENT ORGANIC POLLUTANTS (POPs) CONTROLLED BY THE STOCKHOLM CONVENTION.
- CABLE SHEATH TO BE BLACK, UV STABILISED PACREL 6385N TPE.
- PRINTING MUST BE DURABLE AND ENVIRONMENTALLY RESISTANT.
- CONNECTORS MUST CONFORM TO STANDARD INTERFACE DIMENSIONS.
- SAMPLES MUST BE APPROVED BY PANORAMA ANTENNAS Q.C. BEFORE COMMENCING PRODUCTION.
- IN ORDER TO ASSURE COMPLIANCE WITH THE U.S. DODD-FRANK ACT (SECTION 1502) TIN, GOLD, TANTALUM & TUNGSTEN CONTAINED IN PANORAMA PRODUCTS MUST BE FULLY TRACEABLE TO A SMELTER APPROVED BY THE CONFLICT FREE SOURCING INITIATIVE (www.conflictreesmelter.org)

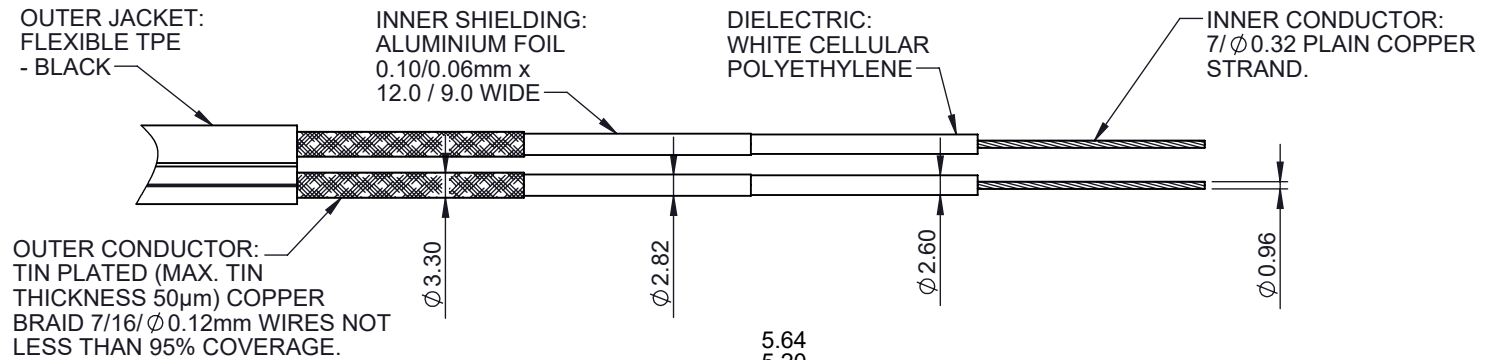

OUTER CONDUCTOR: TIN PLATED (MAX. TIN THICKNESS 50µm) COPPER BRAID 7/16/ Ø0.12mm WIRES NOT LESS THAN 95% COVERAGE.

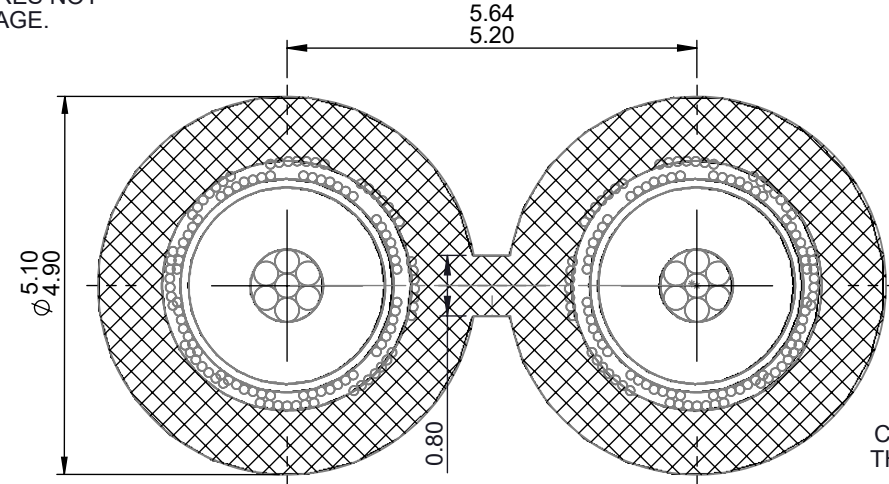

CROSS SECTION THROUGH CABLE SCALE 10:1

				PRODUCT/ASSEMBLY CABLES AND CABLE ASSEMBLIES		DESCRIPTION TWIN ULTRA LOW LOSS DOUBLE SHIELDED 50 OHM COAX CABLE-BLACK						
				MATERIAL SEE NOTES								
				FINISH SEE NOTES								
01019	4	WHITE LINE REMOVED FROM CABLE JACKET	23/11/2015	PE	APPROVED	KD	D.O.CHECK	IC	SCALE	1:1	DIMENSIONS	IN mm
01019	5	NOTES UPDATED WHERE INDICATED.	08/02/2017	AR								
PCN	REV.	DESCRIPTION	DATE	DRN.	WEIGHT	73g/mg		SHEET 1 OF 1				