

**NOTE**

The product described in this document has not been fully tested to ensure conformance to the requirements outlined below. Therefore, TE Connectivity (TE) makes no representation or warranty, express or implied, that the product will comply with these requirements. Further, TE may change these requirements based on the results of additional testing and evaluation. Contact TE Engineering for further details.

AMPLIVAR* 7 Serration Open-Barrel Pigtail Splice Terminal**1. SCOPE**

1.1. Content

This specification covers performance, tests, and quality requirements for the AMPLIVAR* 7-Serration Open Barrel Pigtail Splice Terminal designed to splice unstripped copper magnet wires together alone or with stranded lead wire within a combined total range of 600 to 13,000 CMA. For applications involving aluminum magnet wire, AMPLIVAR* 9 serration open-barrel pigtail splice terminals are required.

1.2. Qualification

When tests are performed on the subject product line, procedures specified in Figure 1 shall be used. All inspections shall be performed using the applicable inspection plan and product drawing.

1.3. Qualification Test Results

Successful qualification testing on the subject product line has not been completed. The Qualification Test Report number will be issued upon successful qualification testing.

1.4. Revision Summary

Revisions to this specification include:

- Initial release of specification.

2. APPLICABLE DOCUMENTS AND FORMS

The following documents form a part of this specification to the extent specified herein. Unless otherwise specified, the latest edition of the document applies. In the event of conflict between the requirements of this specification and the product drawing, the product drawing shall take precedence. In the event of conflict between the requirements of this specification and the referenced documents, this specification shall take precedence.

2.1. TE Connectivity Specifications

| | |
|----------|---|
| 114-2002 | Application Specification – AMPLIVAR* 7-Serration Open Barrel Pigtail Splice Terminal |
| 501-TBD | Qualification Test Report – AMPLIVAR* 7-Serration Open Barrel Pigtail Splice Terminal |

2.2. Commercial Standards and Specifications

| | |
|---------|---|
| EIA-364 | Electrical Connector/Socket Test Procedures Including Environmental Classifications |
|---------|---|

2.3. Reference Documents

| | |
|-------|----------------------------------|
| 109-1 | General Requirements for Testing |
|-------|----------------------------------|

3. REQUIREMENTS

3.1. Design and Construction

Product shall be of the design, construction, materials and physical dimensions specified on the applicable product drawing.

3.2. Materials

Materials used in the construction of this product shall be as specified on the applicable TE drawing.

3.3. Ratings

- A. Voltage Rating: According to applied winding
- B. Current Rating: According to applied wire size
- C. Temperature Rating: -65°C to +150°C

3.4. Performance Requirements and Test Description

The product should meet the electrical, mechanical and environmental performance requirements specified in Figure 1. All tests shall be performed at ambient environmental conditions per EIA-364 unless otherwise specified.

3.5. Test Requirements and Procedure Summary

| Test Description | Requirement | Procedure |
|--------------------------------|---|---|
| Initial Examination of Product | Meets requirements of product drawing | EIA-364-18. Visual and dimensional (C of C) inspection per product drawing. |
| Final Examination of Product | Meets visual requirements | EIA-364-18. Visual inspection. |
| Electrical | | |
| Low Level Contact Resistance | See Figure 4 | EIA-364-23. Subject specimens to 100 milliamperes maximum and 20 millivolts maximum open circuit voltage. See Figure 4 . |
| Temperature Rise vs. Current | 30°C maximum temperature rise at specified current | EIA-364-70, Method 1 Stabilize at a single current level until 3 readings at 5 minute intervals are within 1°C. See Figure 4 . |
| Current Cycling | Measure LLCR initially and every 5000 cycles. | EIA-364-55, Test Condition B, Test Method 4 Subject specimens to 10,000 cycles of 3 minutes ON and 3 minutes OFF at specified current. See Figure 4 and Figure 5 . |
| Mechanical | | |
| Vibration, Random | No discontinuities of 1 micro-second of longer duration. See Note below. | EIA-364-28. Subject specimens to 3.10 G's rms between 20 to 500 Hz. Three hours in each of 3 mutually perpendicular planes. See Figure 6 . |
| Termination Tensile Strength | See Figure 4. | EIA-364-8. Determine tensile strength at a max rate of 25 ± 6 mm per minute. |
| Electrical | | |
| Thermal Shock | See Note below. | EIA-364-32. Subject specimens to 50 cycles between -65°C and +150°C with 30 minutes at each temperature extreme. |

Figure 1 (continued)

| | | |
|-------------------|-----------------|---|
| Humidity Exposure | See Note below. | EIA-364-31, Method III. Subject specimens to 96 hours at 90-95% RH and 40°C. |
| Temperature Life | See Note below. | EIA-364-17, Method A. Subject specimens to 96 hours at 150°C. |

Figure 1 (end)



NOTE

Shall meet visual requirements, show no physical damage, and meet requirements of additional tests as specified in the Product Qualification and Requalification Test Sequence shown in Figure 2.

3.6. Product Qualification and Requalification Test Sequence

| TEST OR EXAMINATION | TEST GROUP (a) | | |
|--------------------------------|-------------------|------|---|
| | 1 | 2 | 3 |
| | TEST SEQUENCE (b) | | |
| Initial Examination of Product | 1 | 1 | 1 |
| Low Level Contact Resistance | 2, 6, 9 | 2, 4 | |
| Temperature Rise vs. Current | 3, 10 | | |
| Current Cycling | | 3 | |
| Vibration, Random | 8 | | |
| Termination Tensile Strength | | | 2 |
| Thermal Shock | 5 | | |
| Humidity Exposure | 7 | | |
| Temperature Life | 4 | | |
| Final Examination of Product | 11 | 5 | 3 |

Figure 2



NOTE

(a) See paragraph 4.2.
(b) Numbers indicate sequence in which tests are performed.

4. QUALITY ASSURANCE PROVISIONS

4.1. Test Conditions

Unless otherwise specified, all the tests shall be performed in any combination of the following test conditions shown in Figure 3.

| | |
|----------------------|------------------|
| Temperature | 15°C – 35°C |
| Relative Humidity | 45% – 75% |
| Atmospheric Pressure | 86.6 – 106.6 kPa |

Figure 3

4.2. Qualification Testing

A. Specimen Selection

Specimens shall be prepared in accordance with applicable instruction sheets and shall be selected at random from current production. Each test group shall consist of a minimum of 5 specimens.

B. Test Sequence

Qualification inspection shall be verified by testing specimens as specified in Figure 2.

4.3. Requalification Testing

If changes significantly affecting form, fit or function are made to the product or manufacturing process, product assurance shall coordinate requalification testing, consisting of all or part of the original testing sequence as determined by development/product, quality and reliability engineering.

4.4. Acceptance

Acceptance is based on verification that the product meets the requirements in Figure 1. Failures attributed to equipment, test setup or operator deficiencies shall not disqualify the product. If product failure occurs, corrective action shall be taken and specimens resubmitted for qualification. Testing to confirm corrective action is required before resubmittal.

4.5. Quality Conformance Inspection

The applicable quality inspection plan shall specify the sampling acceptable quality level to be used. Dimensional and functional requirements shall be in accordance with the applicable product drawing and this specification.

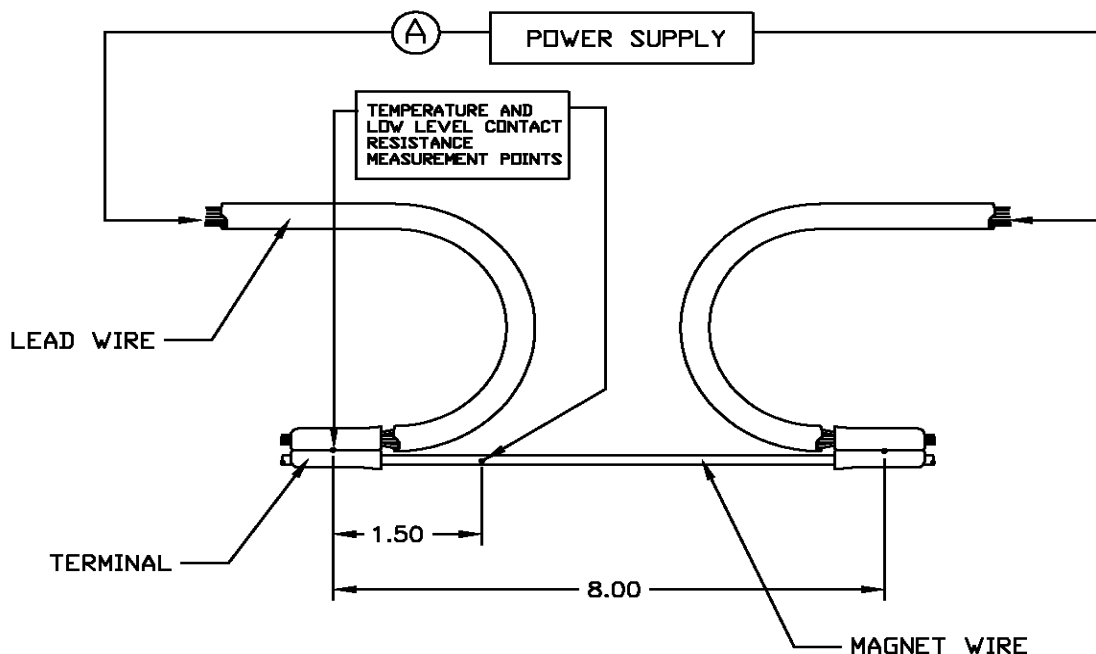

Figure 4: Temperature and Low Level Contact Resistance Measurement Points

| Wire Size | | Current and Resistance Specifications | | | Tensile Strength Specs [lbs] |
|-----------|------|---------------------------------------|--------|--------------------------------|------------------------------|
| AWG | CMA | Copper | | | Copper |
| | | Current (amps) | | Low Level Resistance* (mΩ max) | |
| | | T-Rise | Cycled | | |
| 32 | 64 | 0.5 | 1.5 | 36.0 | 0.7 |
| 31 | 79 | 1.0 | 2.0 | 26.0 | 1.0 |
| 30 | 100 | 1.5 | 3.5 | 23.0 | 1.4 |
| 29 | 128 | 2.0 | 4.5 | 18.0 | 2.1 |
| 28 | 159 | 2.5 | 5.0 | 14.4 | 2.8 |
| 27 | 202 | 3.0 | 6.0 | 10.0 | 3.5 |
| 26 | 258 | 3.5 | 7.5 | 9.1 | 4.2 |
| 25 | 320 | 4.0 | 8.0 | 7.2 | 5.6 |
| 24 | 404 | 5.0 | 9.5 | 5.7 | 7.0 |
| 23 | 511 | 5.5 | 11.0 | 4.6 | 9.1 |
| 22 | 640 | 6.5 | 12.5 | 4.3 | 11.2 |
| 21 | 812 | 7.0 | 14.0 | 3.5 | 14.7 |
| 20 | 1024 | 8.0 | 16.0 | 2.7 | 18.2 |
| 19 | 1289 | 9.0 | 18.0 | 2.2 | 23.1 |
| 18 | 1624 | 10.0 | 20.0 | 2.0 | 29.4 |
| 17 | 2052 | 11.0 | 22.0 | 1.8 | 37.1 |
| 16 | 2581 | 14.0 | 28.0 | 1.6 | 46.2 |
| 15 | 3260 | 16.0 | 32.0 | 1.4 | 58.8 |
| 14 | 4109 | 18.5 | 37.0 | 1.2 | 99.0 |

*Resistance measurement includes crimp + 1.5 inches of wire.

Figure 5: Current, Resistance, and Crimp Tensile Requirements

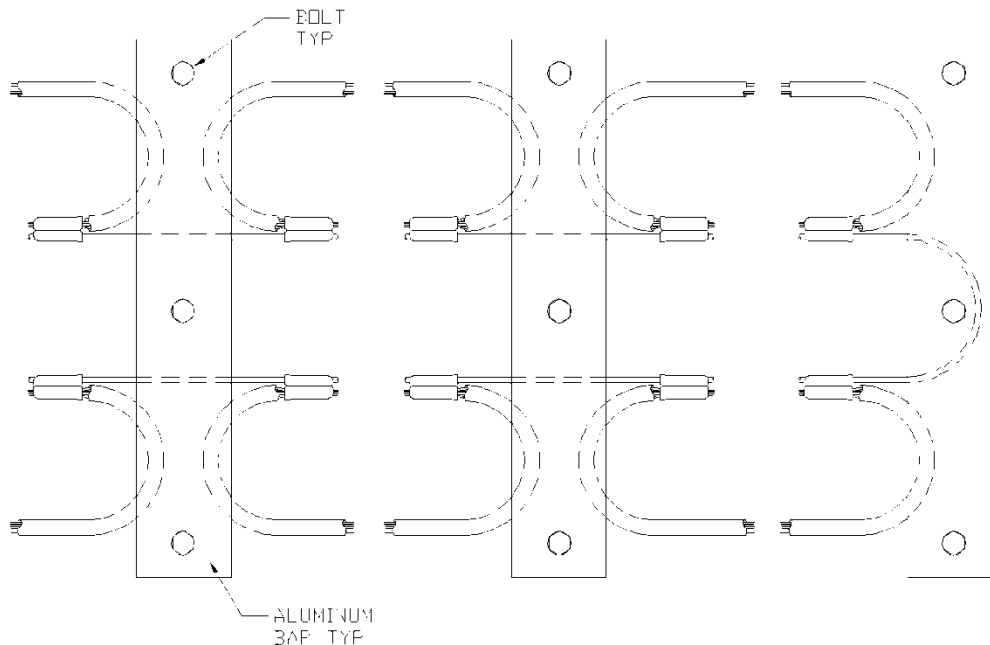

Figure 6: Vibration Mounting Fixture