

LET THERE BE LIGHT

DIMLUX

EXPERT SERIES

Instalatie & Gebruikershandleiding

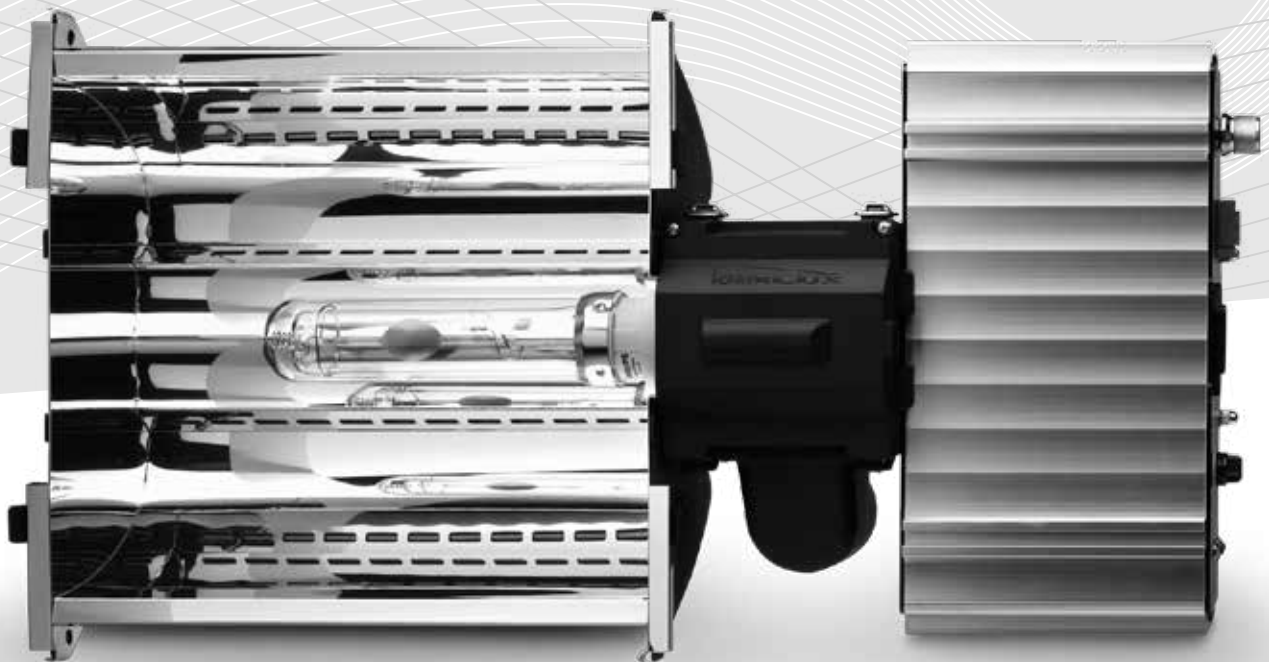

DIMLUX

® DimLux is a registered trademark of
air supplies

DIMLUX EXPERT SERIES SPECIFICATIONS



315W CDM 8 position dim button

- Soft/off, 165W, 205W, 245W, 280W, 315W, 345W, 380W*
- Grid at 315W:
- Grid at 380W:
- Power supply: 230volts
- Nom. Current at 315W: 1,4A
- Nom. Current at 380W: 1,2A
- Fuse (spare fuse in power/in socket)
- Dimensions: 530mm x 275mm x 130mm
- Weight: 4,9kg
- Air outlet diameter: 50mm
- System PPF: 706 μ mol at 380W



600W EL UHF 8 position dim button

- Soft/off, 320W, 90W, 460W, 530W, 600W, 645W, 690W*
- Grid at 600W; min 0,78m² / max 2,0m²
- Grid at 690W; min 0,90m² / max 2,3m²
- Power supply: 230volts
- Nom. Current at 600W: 2,7A
- Nom. Current at 690W: 3,1A
- Fuse: (spare fuse in power/in socket)
- Dimensions: 550mm x 275mm x 130mm
- Weight: 5,1kg
- Air outlet diameter: 50mm
- System PPF: 1341 μ mol at 690W

DIMLUX EXPERT SERIES SPECIFICATIONS



630W dual full spectrum 8 position dim button

- Soft/off, 330W, 410W, 490W, 560W, 630W, 690W, 760W*
- Grid at 630W: min 0,84m² / max 2,0m²
- Grid at 760W: min 1,00m² / max 2,4m²
- Power supply: 230volt
- Nom. Current at 630W: 2,7A
- Nom. Current at 760W: 3,5A
- Fuse: (spare fuse in power/in socket)
- Dimensions: 675mm x 275mm x 130mm
- Weight: 6,3kg
- Air outlet diameter 50mm
- System PPF: 1411 μ mol at 760W



1000W DE EL 8 position dim button

- Soft/off, 600W, 700W, 800W, 900W, 1000W, 1100W, 1200W*
- Grid at 1000W; min 1,40m² / max 3,30m²
- Grid at 1200W; min 1,65m² / max 4,00m²
- Power supply: 230volt
- Nom. current at 1000W: 4,5A
- Nom. current at 1200W: 5,2A
- Fuse: (spare fuse in power/in socket)
- Dimensions: 675mm x 275mm x 130mm
- Weight: 6,3kg
- Air outlet diameter 50mm
- System PPF: 2470 μ mol at 1200

INSTALLATION

Installation

Before installing, make sure the installation complies with the regulations of your country.

The Dimlux Expert series can be controlled with the Dimlux Maxi controller or by using external switching gear. (contactors, timers) Make sure the contactors and timers are designed to match the load of the ballasts.



Maxi Controller

The Maxi Controller can control up to 160 Dimlux Expert fixtures at once. A switchboard, time delay timers, timers and relays (contactors) are no longer needed. The power cord of the fixture can be directly plugged into a power socket. Lights on and off times, brightness and many more items can be set with the Maxi controller.

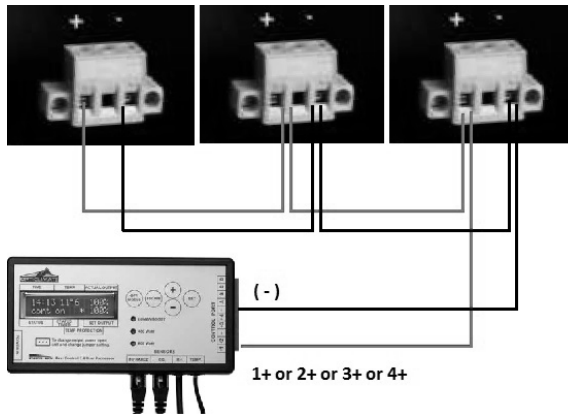

1+ or 2+ or 3+ or 4+

The Maxi Controller sends a signal to the fixtures to switch them on or off. There are 4 ports on the Maxi controller, each port can switch up to 40 fixtures. To connect the signal wire from the controller to the first fixture and looping it to the next, we suggest to use a black/red wire (speaker cable) so + and - are not mixed up.

Please refer to the Maxi Controller manual for specific information regarding to settings and set-up.

INSTALLATION

Mounting

On the rail at the upper side of the fixture are indicators to help you find the perfect balance when mounting the supplied brackets.

- 1 Alpha 98 Optics
- 2 600W and 315W fixture
- 3 1000W and 630W fixture

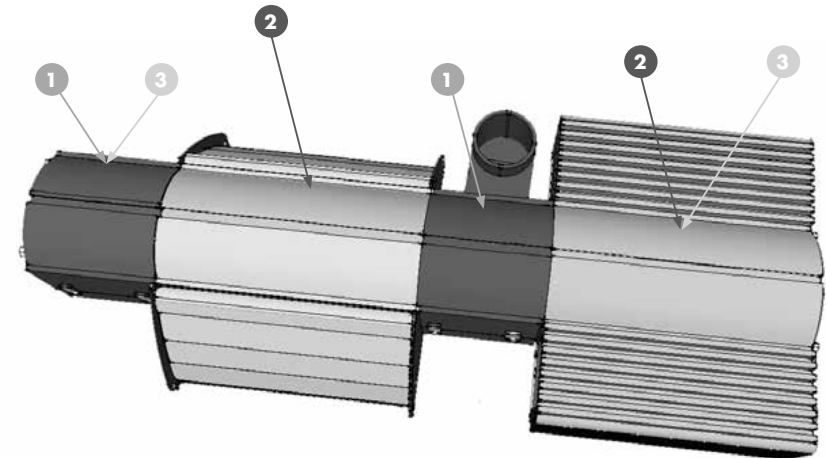

Suitable lamps

Dimlux Expert 315 Watt (dual);

- Philips Greenpower 315 Watt CDM
- Philips Daylight 315 Watt CDM

Dimlux Expert 600 watt EL UHF;

- Philips greenpower 600 watt EL UHF (400volt)
- Sylvania Grolux 600W 400Volt

Dimlux Expert 1000 watt EL UHF

- 1000 watt EL double ended

DIAGNOSE

Diagnose indicators



The ballast comes with 2 diagnose indicator led's. One green and one red. The chart next to the led's indicates what error or status is present.

Off-DB	On-DB	Off-Rem	On-Rem	Open	Short	HTP	LVP	HVP	EOL	State
Off	Off	Flash	On	On	Off	On	Flash	Flash	Strobo	Green
Flash	On	Off	Off	Flash	Strobo	On	Flash	On	Strobo	RED

Off-DB = Ballast is switched off by dimbutton.

On-DB = Ballast is switched on by dimbutton.

Off- Rem = Ballast is switched off by remote (maxi controller)

On-Rem = Ballast is switched on by remote (maxi controller)

Open = Ballast is off because of an open contact or defect bulb

Short = Ballast is off because of shortcircuit or defect bulb

HTP = Ballast is off because of High Temperature Protection (ballast is too hot)

LVP = Ballast is off because of Low Voltage Protection

HVP = Ballast is off because of High Voltage Protection

EOL = Ballast is off because of bulb End Of Life

- When both led's are off, check fuse and power supply.

- Strobo is a very fast flash

Note; make sure the dim button is not in the off position when using the maxi controller.

Lamp replacement

⚠ Always wear gloves!

The 315watt cdm lamp has a bajonet connector. The lamp must be inserted in the fitting in such a way that the contact-pins fit the holes in the fitting. The 2 contact pins are shaped in a different way.

Push the lamp into the fitting and turn to lock the lamp.

The 1000watt DE lamp has 2 slide fittings.



LAMP REPLACEMENT



Remove philips screws



Open latches



Open and remove cover

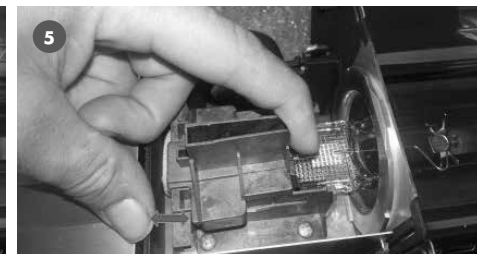
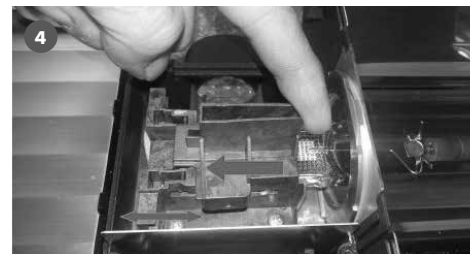

Slide fittings on both sides away from the lamp and lift out lamp

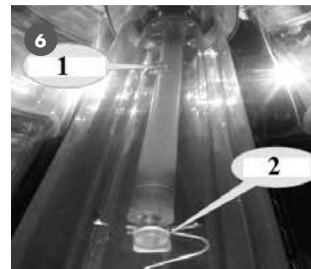

When replacing the lamp, make sure the glass vacuum seal (1) points away from the reflector and the getter (2) is on the ballast side

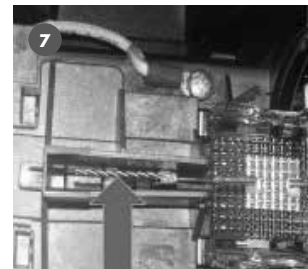

Make sure the contact wire is straight and not twisted before closing the fitting



Slide fittings on both side of the lamp firmly towards the lamp



Slide fittings on both side of the lamp firmly towards the lamp



Close the cover, secure the latches and turn the philips screws back in.

⚠ Test the complete fixture.

REFLECTOR REPLACEMENT

⚠ Remove Bulb(s) before replacement

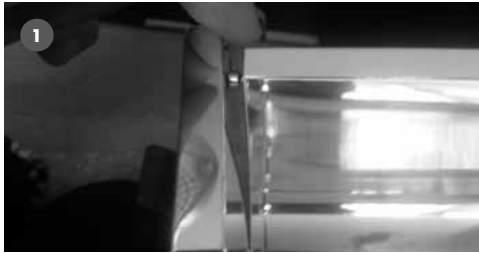

Bend open side to unlock



Open reflector all the way



Pry end of reflector open



Lift reflector straight out

- Discard old reflector, do not re use
- Mount new reflector in opposite way

GENERAL USE

Air

The open reflector versions have openings in the top of the reflective portion in a way that no direct light can shine through. By natural convection, the heat will escape through these openings and thus cooling the lamp.

There is also a 50 mm connection to connect active air removal to reduce the room temperature even more. The amount of air extracted through the 50 mm connection must be 200 m³/hour for each lamp. (no matter if it's a 315/600 or 1000watt fixture)

Additional T-joints and 50mm tube can be supplied, the T-joints are 125-50-125mm, 150-50-150, 160-50-150mm and 200-50-200mm.

Boost and Cooling

Boosting light output will increase the temperature of the lamp. Due to the open structure of the reflector, the lamp temperature will remain within its optimum limits. Without this indirect cooling, the lamp efficiency will decrease. It's even so that when hot air is actively extracted, the efficiency of the lamp will slightly increase. The lamp is not cooled too much because the reflector is constructed in such a way the air is not removed at the lamp itself but around it.

Optical Design

The main goal in designing the reflector was achieving the highest efficiency (light output) possible. It's designed according to the SBCS (Single Bounce Clear Sight) principle which means that each light beam reflects only one single time in the reflector and then goes out directly (Single Bounce). After reflection, the beam is not hindered by the lamp or other parts (Clear Sight). The design from the reflector is optically perfect so that no hammered or textured pattern is needed to spread hotspots. Hammered or textured reflective reflectors are made to improve uniformity and create undesirable multiple reflections inside the reflector and cause internal reflections from the reflector to the lamp causing a decrease in efficiency. This techniques used in our reflector combined with the use of Miro Silver mirror will provide unparalleled results.

Adjusting

The reflector has adjustable side-reflectors with 2 positions, a wide position and a deep position. The "wide" position gives an overlap in a multi reflector setup. The footprint ratio is 0,8:1. When the reflector is next to walls or in a square one lamp room, the adjustable side-reflector is set to the "deep" position and the footprint image is 1:1.

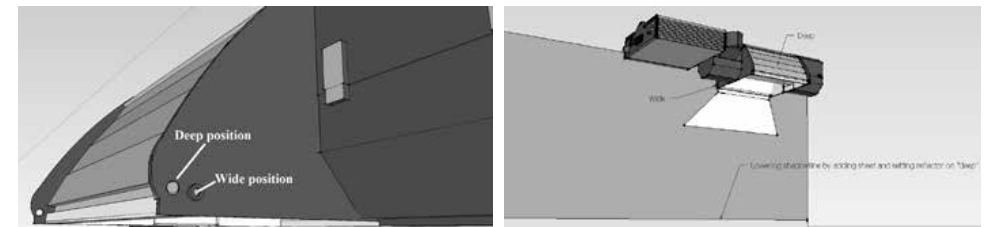

When the side-reflector is moved to the outer position, the reflector is in "deep" position, when moving the side-reflector towards the lamp the reflector is in "wide" position.

Add-on reflectors (wings)

The full fixture or separate Alpha Optics reflector can be fitted with loose add-on reflectors. The reflectors that are adjacent to a wall or corner can be equipped with these wings to minimise reflection losses through a wall. These wings have a hammered texture because the angle of reflection is so large that the SBCS principle is maintained. Reflectors next to a wall all get one wing, reflectors in a corner can be fitted with 2 wings and reflectors in the middle of a room get no wings. Add-on reflectors, minimise wall losses and give more light to the surroundings from the illuminated grid.

The add-on reflectors are available as overlapping and non overlapping models. The overlapping models are used in a multi row set-up and the non overlapping models are used when there is only one row of reflectors in the room.

How high?

There is a very simple and unique way to determine the minimum height of the reflector. Rule of thumb is that the shortest distance from reflector to crop is minimum half the distance between the other reflectors in a multi lamp setup. It doesn't matter if the lamp is 400 watt or 1000 watt. It's obvious that a 1000 watt lamp illuminates a larger surface than a 400 watt lamp, automatically increasing distance between reflector and crop.

A reflector hanging lower than calculated will increase hotspots and decrease uniformity. Lower is not better!

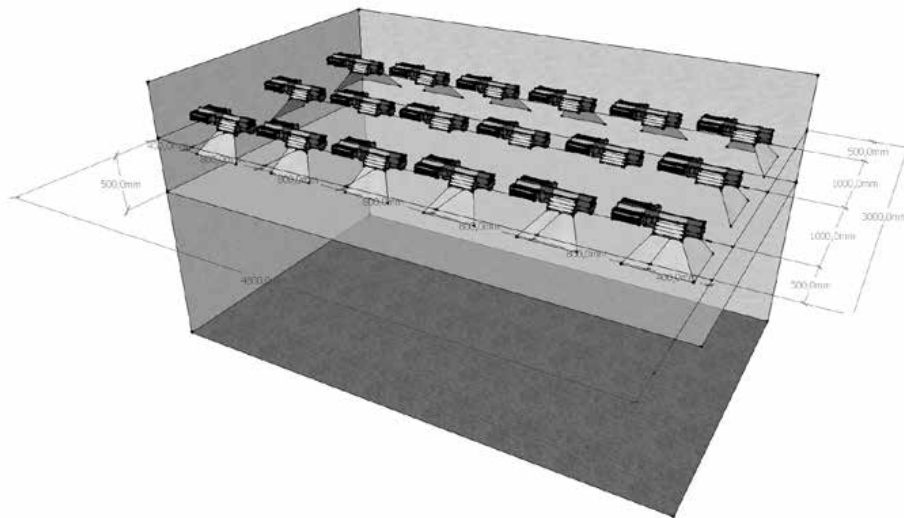

Typical 600watt lay out

Distance

Distance between reflectors depends on the lamp, not the reflector. Maximum light output for most crops is 1500 umol/m2/s.

Example:

The 600 watt EL UHF lamp output is 1190 umol, with boost it's almost 1370 umol/m2/s. There will be some light loss due to reflections loss from walls and reflector. Because boost gives more efficiency with cooled lamps and using add-on wings the light output will be almost the same. 1370 umol/m2/s is almost the limit when illuminating 1m2 with 1 reflector and a 600watt EL UHF lamp. 0,8m2 is the maximum.



Dimlux B.V.
Amsterdam, the Netherlands
www.dimlux.nl

MADE IN HOLLAND

