

Specification 4771

Alsace Three Hole Sink Mixer with Lever Handles

- 1/4 turn ceramic disc flow control. ● vernier insert for accurate handle alignment.
- unique handle construction with integral bearing ring. ● Flexible connectors for easier installation.

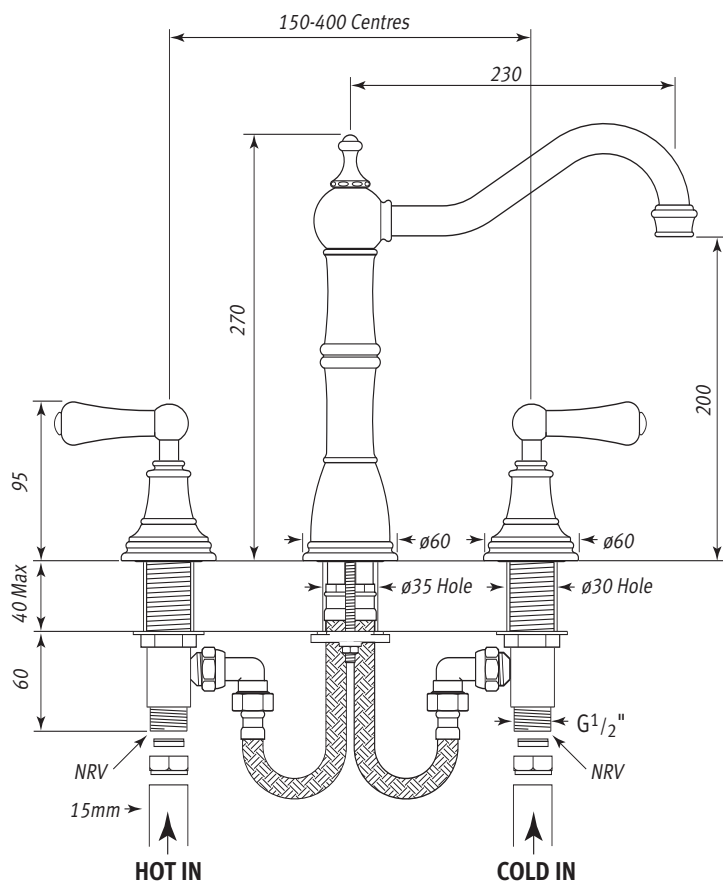

Temp Range:

min 1°C/34°F
max 85°C/185°F

Recommended working pressure:

min 1 bar/15 psi
max 5 bar/75psi

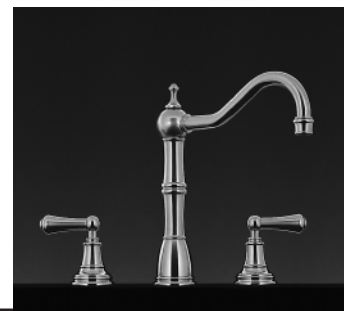

Specification 4771

Alsace Three Hole Sink Mixer with Lever Handles

- 1/4 turn ceramic disc flow control. ● vernier insert for accurate handle alignment.
- unique handle construction with integral bearing ring. ● Flexible connectors for easier installation.

Where * Indicated Specify Colour.

