

Specification 4761

Picardie Monobloc Mixer with Lever Handles

- 1/4 turn ceramic disc flow control. ● vernier insert for accurate handle alignment.
- unique handle construction with integral bearing ring. ● flexible connectors for easier installation.

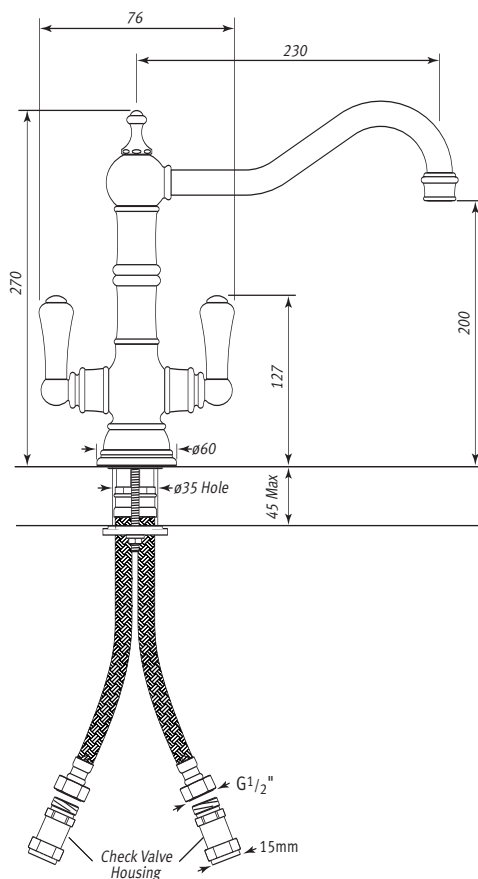

Temp Range:

min 1°C/34°F
max 85°C/185°F

Recommended working pressure:

min 0.5 bar/7 psi
max 5 bar/75 psi



Specification 4761



Picardie Monobloc Mixer with Lever Handles

- 1/4 turn ceramic disc flow control. ● vernier insert for accurate handle alignment.
- unique handle construction with integral bearing ring. ● flexible connectors for easier installation.

Where * Indicated Specify Colour.

