

Callisto Three Hole Sink Mixer with 'U' Spout

- 1/4 turn ceramic disc flow control
- Vernier insert for accurate handle alignment
- Unique handle construction with integral bearing ring
- Flexible connectors for easier installation

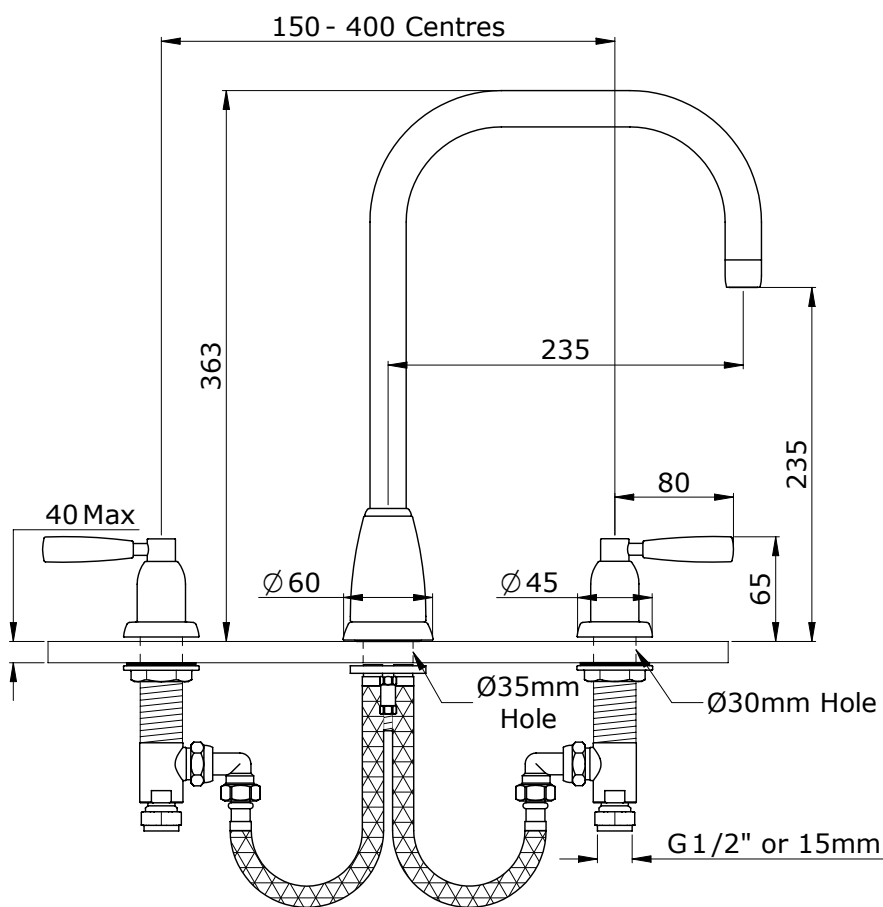

Temp Range:
Min 1°C / 34°F
Max 85°C / 185°F

Recommended Working Pressure:
Min 1bar / 15psi
Max 5bar / 75psi

Packed Weight:
4.2Kg

Available Finishes:

- Chrome
- Nickel
- Pewter

Callisto Three Hole Sink Mixer with 'U' Spout

* Where indicated specify colour

